

www.swisherinc.com

OWNER'S MANUAL

MODEL NO.

STARTING SERIAL #:
L118-023001

RC11544BS

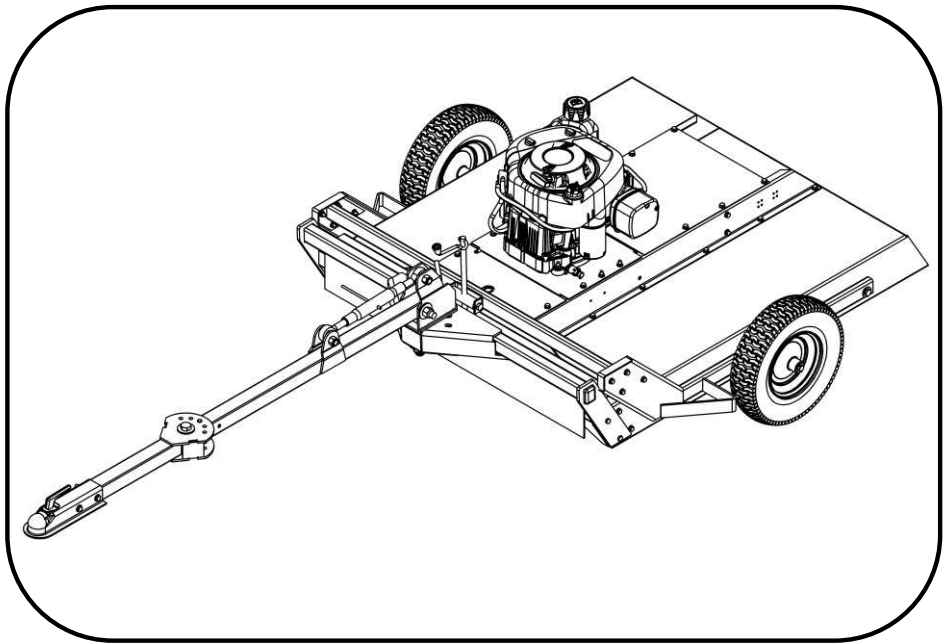

44" COUNTRY CUT TRAIL CUTTER



IMPORTANT

Read and follow all
Safety Precautions
and Instructions
before operating this
equipment.

Assembly
Operation
Service and Adjustment
Repair Parts

SWISHER[®]

SWISHER ACQUISITION INC.
1602 CORPORATE DRIVE, WARRENSBURG, MISSOURI 64093
PHONE (660) 747-8183 FAX (660) 747-8650

Made In The
USA
of US and Global Parts

LIMITED WARRANTY

The manufacturer's warranty to the original consumer purchaser is: This product is free from defects in materials and workmanship for a period of one (1) year from the date of purchase by the original consumer purchaser.

We will repair or replace, at our discretion, parts found to be defective due to materials or workmanship. This warranty is subject to the following limitations and exclusions:

- 1) Engine Warranty All engines utilized on our products has a separate warranty extended to them by the individual engine manufacturer. Any engine service difficulty is the responsibility of the engine manufacturer and in no way is Swisher or its agents responsible for the engine warranty. The Briggs & Stratton Engine Service Hot Line is 1-800-233-3723.

- 2) Commercial Use This product is not intended for commercial use and carries no commercial warranty.

- 3) Limitations This warranty applies only to products, which have been properly assembled, adjusted, and operated in accordance with the instructions contained within this manual. This warranty does not apply to any product of Swisher that has been subject to alteration, misuse, abuse, improper assembly or installation, shipping damage, or to normal wear of the product.

- 4) Exclusions Excluded from this warranty are normal wear, normal adjustments, and normal maintenance.

In the event you have a claim under this warranty, you must return the product to an authorized service dealer. All transportation charges, damage, or loss incurred during transportation of parts submitted for replacement or repair under this warranty shall be borne by the purchaser. Should you have any questions concerning this warranty, please contact us toll-free at 1-800-222-8183. The model number, serial number, date of purchase, and the name of the authorized Swisher dealer from whom you purchased the mower will be needed before any warranty claim can be processed.

THIS WARRANTY DOES NOT APPLY TO ANY INCIDENTAL OR CONSEQUENTIAL DAMAGES AND ANY IMPLIED WARRANTIES ARE LIMITED TO THE SAME TIME PERIODS STATED HEREIN FOR ALL EXPRESSED WARRANTIES. Some states do not allow the limitation of consequential damages or limitations on how long an implied warranty may last, so the above limitations or exclusions may not apply to you. This warranty gives you specific legal rights and you may have other rights, which vary from state-to-state. This is a limited warranty as defined by the Magnuson-Moss Act of 1975.

Thank you for choosing Swisher's 44" Trail Cutter. Before operating your cutter, please read, understand and follow all of the safety precautions and other instructions explained in this manual. As with all power equipment, lawn mowers and cutters can be potentially dangerous if improperly used.

SAFETY PRECAUTIONS



This Safety Alert Symbol indicates important messages in this manual. When you see this symbol, carefully read the message that follows and be alert to the possibility of personal injury.

Read this manual completely. This machine can amputate hands and feet, and throw objects. Failure to observe the following safety instructions could result in serious injury or death.

- Read the manual. Learn to operate this machine safely.
- Always disconnect the spark plug wire and place the wire where it cannot contact the spark plug, to prevent accidental starting the engine when setting up, transporting, adjusting or making repairs.
- Keep all shields and guards in place.
- Understand the speed, steering and stability of this machine. Know the positions and operations of all controls before you operate this machine. Check all of the controls in a safe area before starting to work with this machine.
- Allow only responsible adults who are familiar with these instructions to operate this machine. **Never allow children to operate this machine.**
- Clear the area of objects such as rocks, toys, wire, etc. that can be picked up and thrown by the blade.
- Be sure the area is clear of other people before mowing. Be aware of the cutters discharge direction and do not point at anyone. **Stop the machine** if anyone enters the cutting area. Children are often attracted to the machine and the mowing activity. *Never assume that children will remain where you last saw them.* Keep children under the watchful care of another responsible adult.
- **No riders!**
- Do not put hands or feet near or under rotating parts.
- Do not mow in reverse. **Always look down and behind before and during backing.**

- Turn off the blades when not cutting. Before leaving the machine, turn off the blades and stop the engine.
- Watch for traffic when operating near or crossing roadways.
- Do not operate the cutter if it has been dropped or damaged in any manner or if the mower vibrates excessively. Excessive vibration is an indication of damage. Repair cutter as necessary.
- Dress properly. Do not operate the cutter when barefoot or wearing open sandals. Wear only solid shoes with good traction when cutting.
- Never allow operation by untrained persons.
- Do not operate the machine while under the influence of alcohol or drugs.
- Do not operate on slopes greater than 15 degrees.
- Never tamper with safety devices. Check their proper operation regularly.
- Stop and inspect the equipment if you strike an object. Repair, if necessary, before restarting. Never make adjustments or repairs with the engine running.
- Cutter blades are sharp and can cut. Wrap the blades or wear gloves, and use extra caution when servicing them. Do not operate at too fast a rate.
- Return lever to its vertical position to disengage blades.
- The braking system is applied when the blades become disengaged. It is designed to bring the blades to a quick stop (approximately 7 seconds). Each Trail Cutter brake system has been set at the factory. For safety, the consumer should not alter the braking system.

ASSEMBLY

Tools Required:

	Wrench/Socket	Qty.	Size
		(1)	1-1/8"
		(1)	1-1/16"
		(2)	15/16"
		(2)	9/16"

- Disengage spark plug wire and place where it cannot make a connection.
- **Refer to Fig. 1 pg. 11.** Attach hitch assembly parts to front of mower using 3/8-16 X 1 1/4 bolts and secure with 3/8-16 locknuts. Insert 3/4-10 x 4 1/2" bolt through the bottom hole of the pivot assembly, (2) 3/4 washers, and hitch tube and secure with 3/4-10 nut. Tighten nut tight until tube is clamped tight, then back off 1/4 turn to allow tube to pivot.
- Insert 5/8-11 X 2 1/2 bolt through the top of the Pivot Assembly and Top Link and secure with 5/8-11 nut. Insert 5/8-11 x 2 1/2 bolt through the tabs on the top of the Hitch bar and Top Link and secure with 5/8-11 nut.
- Place 2" Hitch Coupler on the end of the Hitch Bar. Align Holes with Hitch Bar and Coupler. Fasten using (2) 3/8-11 x 3 Bolts, (4) 3/8 Washers, and (2) 3/8-11 Locknuts. Tighten nuts securely.
- The hitch can be adjusted up or down to level the deck from front to back. (See figure 2 page 11)
- Check engine oil. All engines are filled with oil at the factory. Verify oil level and add if necessary before starting engine. (See Engine Owner's Manual)
- Verify fuel level and add if necessary before starting engine.
- Reconnect spark plug wire.
- Refer to Owner's Manual pg 5 for proper operating procedures.

OPERATING YOUR TRAIL CUTTER



The operation of any mower can produce foreign objects to be thrown into the eyes, resulting in severe eye damage. Always wear certified safety glasses or wide-vision safety goggles over spectacles before starting any cutting machine and while operating such a machine.



The operation of any mower produces sound waves that are damaging to the human ear. Ear protection is recommended.



CAUTION! Tragic accidents can occur if the operator is not alert to the presence of children. Children are often attracted to the machine and the mowing activity. *Never assume that children will remain where you last saw them.*

INTENDED USE

The 44" Trail Cutter is designed to clear dense areas of grass and cut saplings up to 3" thick on meadows and small estates. **It is not intended to create a finish cut on lawns.** Your Trail Cutter should be towed behind an ATV, golf cart, lawn tractor or other approved vehicle. It is not recommended for speeds exceeding 5 MPH.

ATTACHING TRAIL CUTTER TO TOW VEHICLE

- Back vehicle up to desired towing position.
- Offset the Trail Cutter to the side opposite the tow vehicle discharge (if any). This prevents the tow vehicle from throwing grass into Trail Cutter engine.
- Using the 7365 2" ball coupler, connect the hitch to the vehicle your machine will be towed with. Once attached, adjust the cutting height and level the mower by rotating the adjustment rod (See figure 2 page 11).

TRANSPORTING CUTTER

- Stop Trail Cutter.
- Place Trail Cutter deck in its highest position.
- When transporting without the use of a tow vehicle, remove spark plug wire and place it where it cannot contact the spark plug.

STOPPING THE ENGINE

- Make sure the tow vehicle parking brake is set.
- Disengage cutting blades.
- Reduce engine to idle speed and allow engine to run momentarily for cooling.
- Turn the key to the off position.

ENGAGING BLADES

Note: Do not attempt to start the unit with the T-handle console in the “**ENGAGED**” position.

- Engage blades by pulling down the T-handle lever into the horizontal position.
- Return lever to the vertical position to disengage blades. See Fig 10 pg 17.
- The braking system is applied when the blades become disengaged. It is designed to bring the blades to a quick stop (approximately 7 seconds). Each Trail Cutter brake system has been set at the factory the consumer should not alter any part of the brake system.

BREAKING IN YOUR CUTTER

- Set the vehicle parking brake and chock the wheels to prevent accidental rolling.
- While engine is running, engage the blade control.
- In a safe environment, (i.e. no children or pets) allow the blades to rotate and the engine to run at full throttle for 5 minutes, breaking in the belt for longer life.
- Disengage the blades and shut off the engine.

STARTING THE ENGINE

See engine manufacturer’s recommendations for the type and amount of oil and fuel used.

- Make sure the tow vehicle parking brake is set, mower is level, and blades are disengaged. Engine must be level to accurately check and fill oil. Do not overfill.
- Check spark plug wire, oil, and fuel.
- Check all electrical connections for buildup of debris.
- Set engine idle to “**CHOKE**” position.
- Turn key to the “**RUN**” position.
- Pull rope with a single fluid motion.
- Set engine idle at maximum RPM for best performance.
- Allow engine to run a few moments before engaging blades.



CAUTION: SHUT OFF THE CUTTER ENGINE AND REMOVE SPARK PLUG WIRE FROM SPARK PLUG BEFORE MAKING ANY ADJUSTMENTS TO THE CUTTER.

IMPORTANT: This engine is not equipped with a spark arrester muffler. It is a violation of California Public Resource Code Section 4442 to use or operate the engine on any forest-covered, brush-covered, or grass-covered land. Other states or federal areas may have similar laws.

CUTTER HEIGHT ADJUSTMENT

- There is approximately 4” of height adjustment.
- Rotate height adjust crank handle in a clockwise direction to lower the mower deck. Rotate counterclockwise to lift the mower deck.
- Dense areas should be cut twice.
- Push handle down to lock height position.
- Adjust the top link located on the front of the hitch to level the mower after adjusting the cutting height (See figure 2 page 11).

TOW HITCH OFFSET

- If towing with a lawn tractor, offset the rough cut mower to the opposite side of the lawn tractor grass discharge.
- Swisher recommends if the tow vehicle is equipped with a mid-mount mower to overlap the cut approximately 6”. This may vary depending on mowing terrain, obstacles, and/or tow vehicle. Always keep safety the first priority.
- Always keep the tow vehicle cutter raised higher than the Trail Cutter.

STARTING TO CUT

- Adjust the cutting height.
- Double check tow vehicle to rough cut mower attachment.
- Start mower engine and set throttle to “FAST” for best cutting performance.
- Slowly engage T-handle lever. See Fig 8 pg 16.
- Carefully mount tow vehicle and start mowing at a slow travel speed.

STOPPING THE CUTTING SESSION

- Bring tow vehicle to a complete stop, set the parking brake and disengage blades.
- Turn key switch to the “OFF” position.
- Always remember to remove keys to avoid irresponsible usage.

SUGGESTED CUTTING PRACTICES

- Operate cutter engine at full throttle to assure the best cutting performance and maximum material discharge.
- Allow wet grass to dry. Wet grass will clump and collect under the mowing deck.
- Cutter should be started with tow vehicle in low gear and increased only as safe mowing conditions permit. Cutting speed should not exceed 5 MPH.
- Cutting conditions and the types of grass will vary from place to place. You may find when cutting dense areas that the pressure of the wheel tracks may cause the grass to be pushed down and not effectively mowed. If this happens you may want to mow the area twice. Once with the cutter raised and the second cutting at the desired height. The second cutting should be at a right angle from the previous for best results.

- Reducing the travel speed will help cut dense growth. This allows the blades the time necessary to make its initial cut, and regain momentum to continue cutting. The engine may stall if you are mowing too fast!
- Do not attempt to cut areas that the tow vehicle cannot maneuver through and/or slopes that you do not feel comfortable riding.

CUTTER MAINTENANCE

GENERAL RECOMMENDATIONS

The warranty on this cutter does not cover items that have been subjected to operator abuse or negligence. To receive full value from the warranty, operator must maintain unit as instructed in this manual.

Some adjustments will need to be made periodically to maintain your unit properly. Refer to your engine manual for recommended fuel, oil, and service parts.

BEFORE EACH SEASON

A new spark plug and clean air filter assure proper air fuel mixture and help your engine run better and last longer.

- Replace the spark plug.
- Clean or replace the air filter.
- Check blades and belts for wear.

BEFORE EACH USE

- Check engine oil level. Do this twice to ensure an accurate reading.
- Check condition of air filter and clean or replace if necessary.
- Check blade operation.
- Check for loose fasteners.
- Lubricate threads of adjustment rod P/N 4006. See Fig 5 pg 13.

DAILY MAINTENANCE

Make sure all nuts and bolts are tight and cotter pins and retainer springs are secure. Keep blades sharp. Observe all safety precautions.

BLADE CARE AND SERVICE

For best results cutter blades must be kept sharp. The blades can be sharpened with a few strokes of a file or grinding wheel. Do Not attempt to sharpen while on the cutter.

Important: Replace blades that have been damaged or deeply nicked.

Important: Check blade and spindle hardware on a regular basis to make sure nuts are tight.



CAUTION: DO NOT HANDLE CUTTER BLADES WITH BARE HANDS. CARELESS OR IMPROPER HANDLING MAY RESULT IN SERIOUS INJURY.

GENERAL TROUBLESHOOTING

The unit is not cutting level.

- Level deck. Check air pressure of all tires; make sure they are equal. See tires for maximum inflation.
- Without the engine running, make certain blades are installed identically.

The engine will not start.

- Disengage blades, turn key switch to the “OFF” position, check all electrical connections and inspect spark plug and wire.
- Contact engine manufacturer or qualified mechanic.

Engine runs poorly.

- See engine manual.
- Check the throttle adjuster.
- Replace fuel, check fuel filter and fuel line.
- Check spark plug and gap.

Cutter bounces excessively while towing.

- Decrease tire pressure.
- Tow at a lower speed.



IF PROBLEMS PERSIST HAVE A QUALIFIED MECHANIC SERVICE THE CUTTER. NEVER ATTEMPT TO MAKE AN ADJUSTMENT THAT YOU ARE NOT SURE IS CORRECT. DOING SO CAN CAUSE OTHER PROBLEMS.



SAFETY AND OPERATIONAL DECALS

Replace decal immediately if damaged. Order by part number from Swisher. 1-800-222-8183, 8-5 CT M-F



19976-SWISHER FLAG DECAL



OD29-DANGER DECAL



OD33-5MPH DECAL



OD36-DEFLECTOR DECAL



OD55-DANGER DECAL



OD45-WARNING DECAL



OD10-ENGAGE DECAL



OD99-OFF/RUN DECAL



OD99112 LARGE SWISHER LOGO

UNCRATING & SET-UP DIAGRAM

Item #	Description	Part #
1	Bolt - Hex, 5/8-11 X 2 1/2"	NB667
2	Bolt - Hex, 3/4-10 X 4 1/2"	21130
3	Weldment - Hitch Mount; RC44	21114*
4	Top Link - Cat 0 W/ Adjusting Rod	21103
5	Weldment - Hitch Bar Lower Arm	21108*
6	Pin - Clevis 3/8 X 3 ZP	21131
7	Pin - #39 Hair Pin (A155H)	NB127
8	Washer - 3/4 ID 18 GA	NB179
9	Nut - 3/4-10 Lock	21132
10	Nut - 5/8-11 Lock	21138

Item #	Description	Part #
9	Nut - 3/4-10 Lock	21132
10	Nut - 5/8-11 Lock	21138
11	Washer - 3/4" SAE Flat	NB146
12	Nut - 3/8-16 Lock	NB182
13	Bolt - Hex, 3/8-16 X 1 1/4	NB618
14	Washer - 3/8" SAE Flat	NB272
15	Bolt - Hex, 3/8-16 x 3	NB150

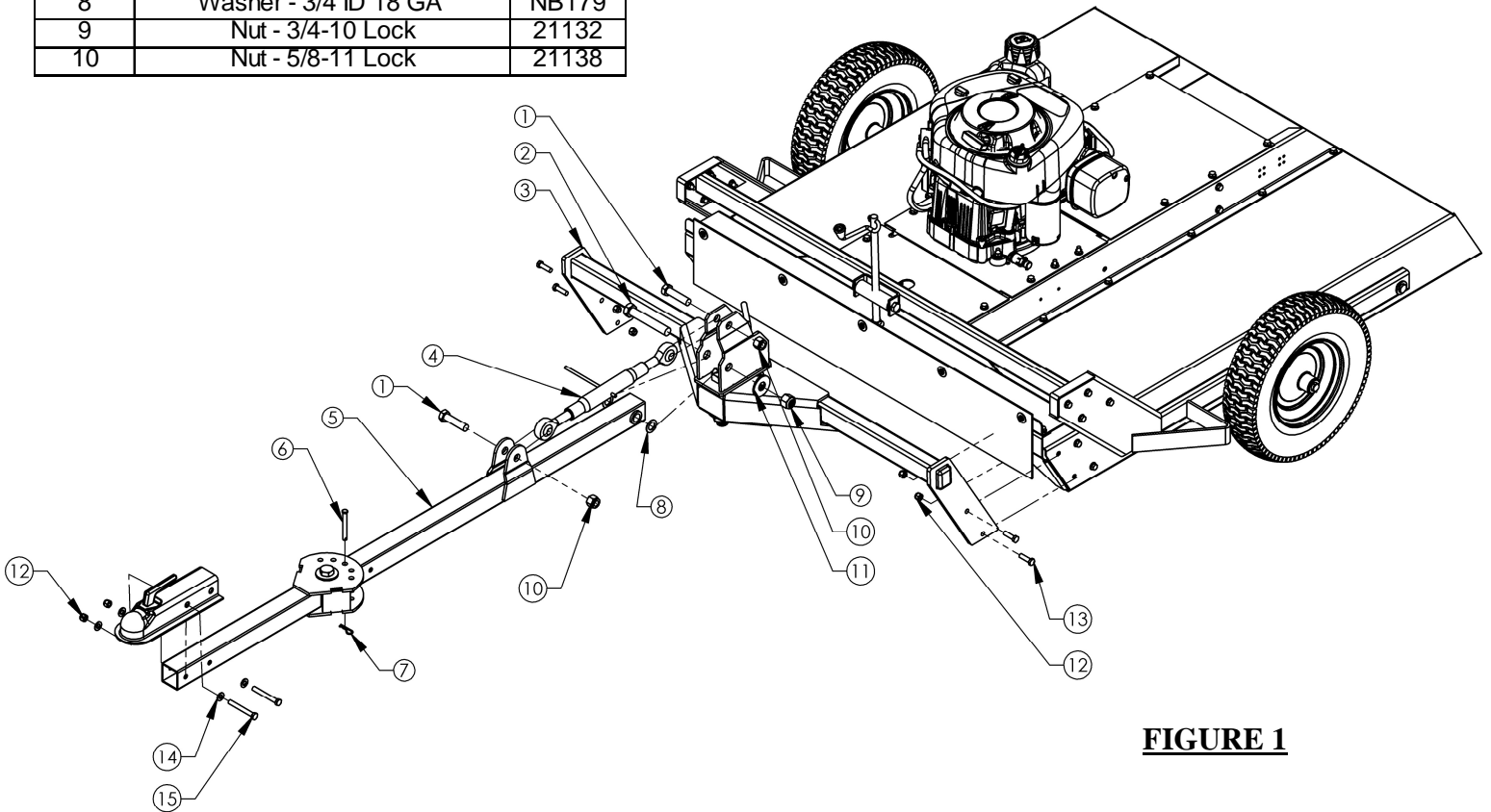

FIGURE 1

DECK LEVELING DIAGRAM

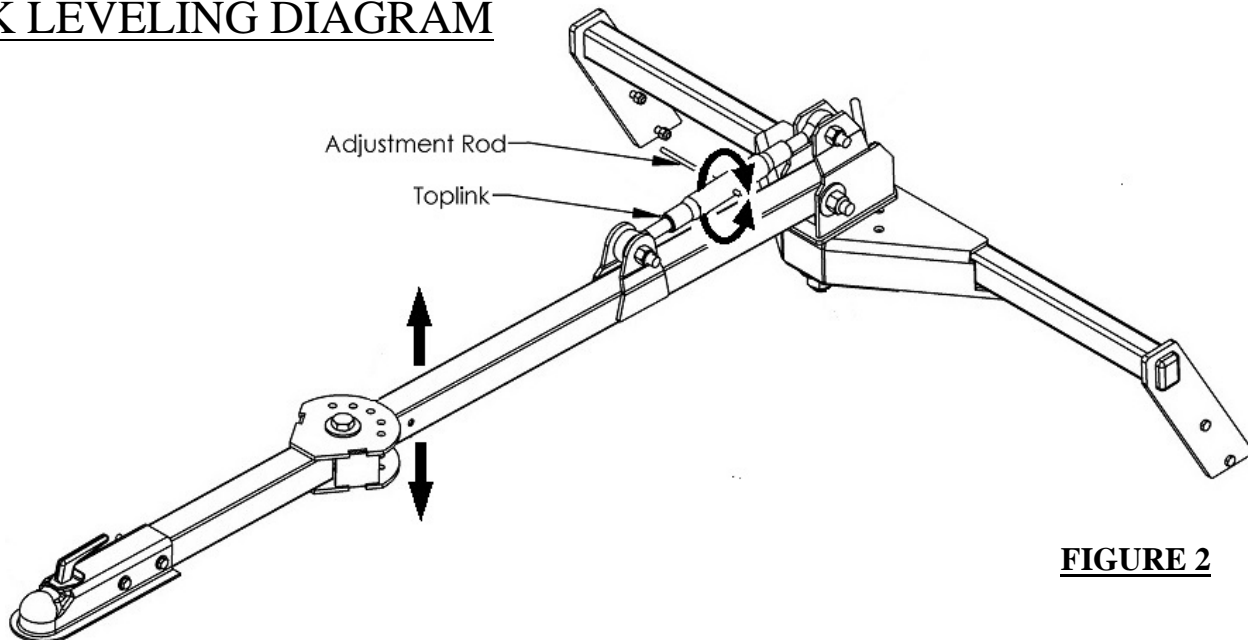

FIGURE 2

FRONT TO BACK ADJUSTMENT

For best cutting results, the cutter deck should be parallel to the ground. To check parallel adjustment, measure the distance from the bottom edge of the deck in both the front and rear of the deck. This adjustment is best done while the tow vehicle and Trail Cutter are connected.

FRONT SKIRT ASSEMBLY

FIGURE 3

Item #	Description	Part #
1	Nut - Serr Flange, 1/4-20 Grade 5 ZY	NB524
2	Rubber Flapper	10384
3	Washer - Fender, 1/4X1 1/4OD Gr 2 ZY	11520
4	Bolt - Serr Flange, 1/4-20 X 3/4 GR5 ZY	NB690

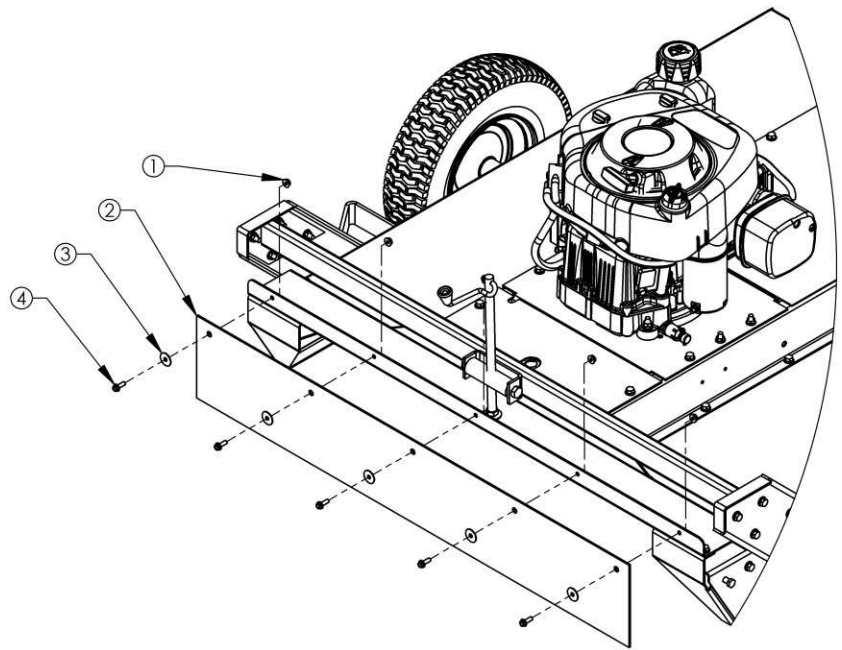

HITCH ASSEMBLY

FIGURE 4

Item #	Description	Part #
1	Weldment - Pivot Bracket Assembly	21102*
2	Weldment - Hitch Mount; RC44	21114*
3	Spring - Compression	12364
4	Pin - 1/8" X 1" Cotter	NB126
5	Washer - Flat, 1/2"-12Ga	18823
6	Pin - Pivot Latch	21118
7	Nut - Hex Lock 1"-8	21163
8	2" Ball Coupler	7365
9	Bolt - Hex, 3/8-16 X 3"	NB150
10	Washer - 3/8 SAE	NB272
11	Nut - 3/8-16 Lock	NB182
12	Bolt - 3/4-10 X 3 3/4"	21129
13	Nut - 3/4-10 Lock	21132
14	Washer - 3/4" SAE	NB146
15	Nut - 5/8-11 Lock	21138
16	Weldment - Hitch Bar Lower Arm	21108*

Item #	Description	Part #
17	Weldment - Upper Hitch Arm Assembly	21117*
18	Pin - Clevis 3/8 X 3 ZP	21131
19	Bushing - Machine; 1" ID	21121
20	Washer - Uss Flat, Ø1" X Ø2.5"	NB569
21	Plug - 1 1/2" X 2", End Cap	21127
22	Botl - 5/8-11 X 2 1/2"	NB667
23	Top Link - Cat 0 W/ Adjusting Rod	21103
24	Washer - 1" Belleville	NB738
25	Bolt - 3/4-10 X 4 1/2"	21130
26	Pin - #39 Hair Pin (A155H)	NB127
27	Bolt - 3/8-16 X 1 1/4"	NB618
28	Washer - 3/4 ID X 1 1/4 OD 18 GA	NB179

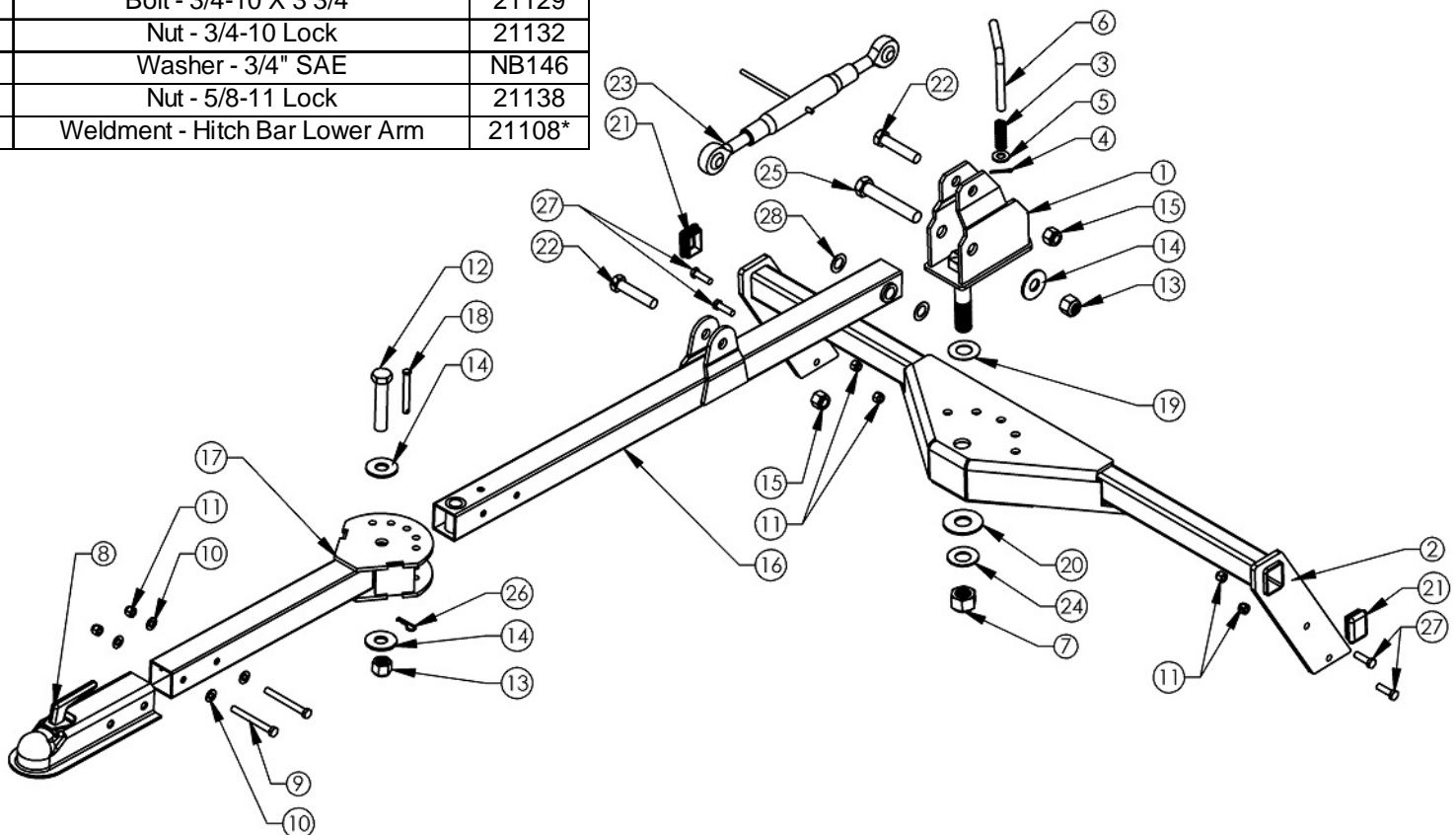

When ordering replacement parts
 * = USE PAINT CODE: TK=BLACK

MOTOR BASE, WHEEL & HEIGHT ADJUSTMENT ASSEMBLIES

FIGURE 5

Item #	Description	Part #	Item #	Description	Part #
1	Nut - 5/16-18 Serrated Flange	NB170	16	Washer - Nylon 1/4	NB194
2	Nut, Push - 5/16	NB117	17	Motor Base	10343*
3	Knob Height Adjustment	H7K	18	Cover - Rear	19073*
4	Height Adjust Rod	4006	19	Belt - Blade, 50"	20655
5	Bolt - 1/2-13 X 1 1/2	10046	20	1/2-13 Nyloc Nut	NB281
6	1/2-13 Jam Nut	NB118	21	Spacer	10290
7	Washer - Bellville, .512x1.26x .138	10291	22	5/8 ID X 1 OD 14 GA Washer	NB149
8	1/2 NR Mach Bushing 14 GA	NB177	23	Washer - 13/16 ID X 1 1/4 OD X 1/8	NB195
9	Screw - .312-18 x .75	26X249	24	Bolt - 1/2-13 X 2 1/2 Hex Tap	NB588
10	Front Cover	10367*	25	Weldment - Axle Bar, Left	10355*
11	Bolt - 5/16" X 18 UNC X .75" Flange Head	NB596	26	Tube - Front Weldment	10342*
12	Single Point Pivot Block	4007*	27	5/16-18 X 1 Serrated Flange Bolt	10548
13	Crank Rod	ES214	28	Wheel/Tire - 4.8 X4-8	17383K
14	1/2-13 2-Way Jam Lock Nut	NB121	29	1/8" X 1" Cotter Pin	NB126
15	Weldment - Axle Bar, Right	10356*			

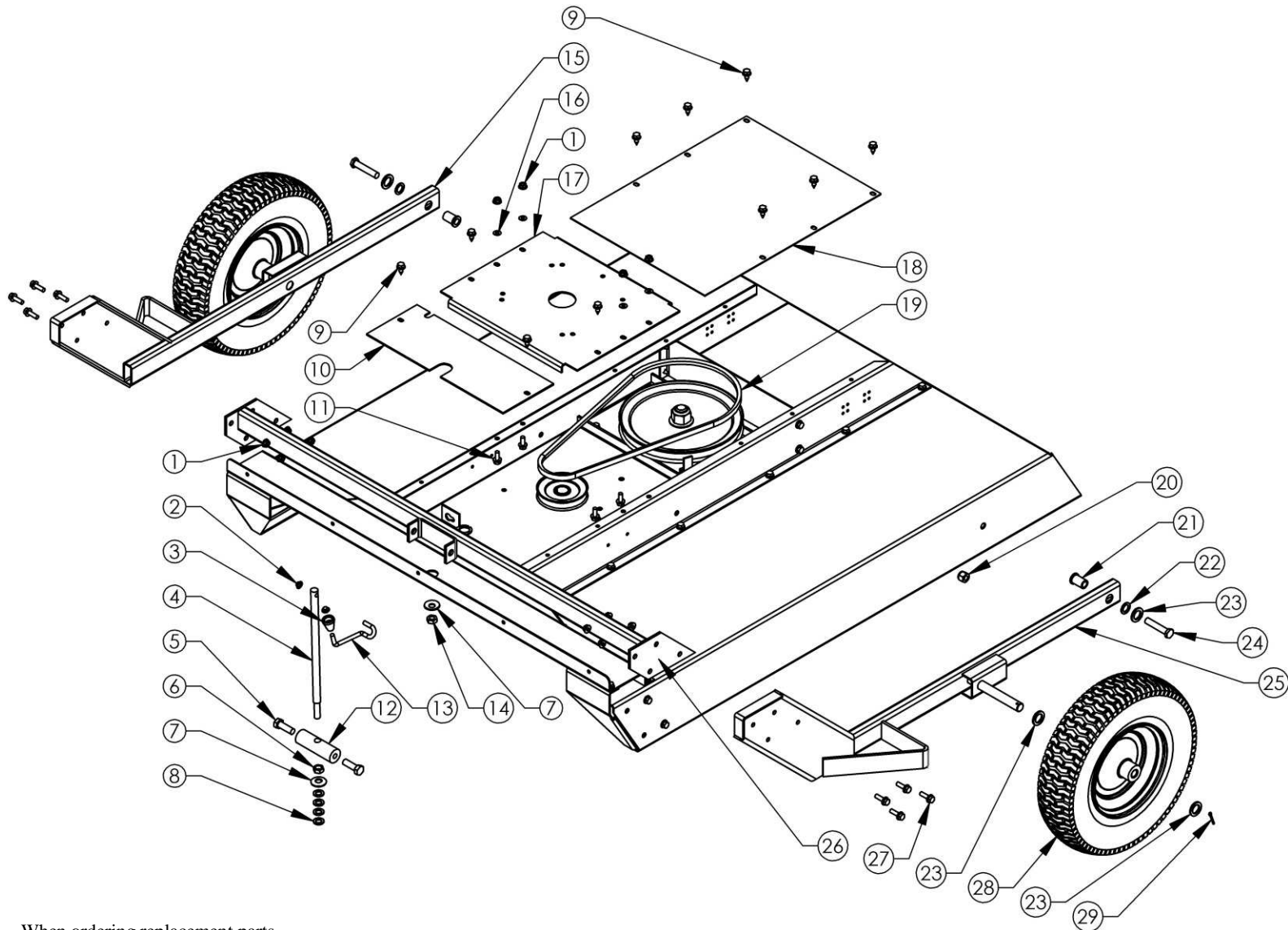

When ordering replacement parts
* = USE PAINT CODE: TK=BLACK

DECK ASSEMBLY

FIGURE 6

Item #	Description	Part #
1	Deck - Weldment	15727*
2	Screw - .312-18 x .75	26X249
3	Side Gusset - Left	15056*
4	Nut - 5/16-18 Serrated Flange	NB170
5	Side Gusset - Right	15057*
6	Z Bracket, Jack Support	15055*
7	Front Rail/Deck Support	15054*
8	Remote Cable Mount - Bolt On	15059*
9	Bracket - Remote Cable Detent	15606*
10	Rail - RT44, Right	17358*
11	Weldment - Blade Mount	15005*
12	Rear Z Rail Brace - RT44	16371*
13	Rail - RT44, Left	17357*

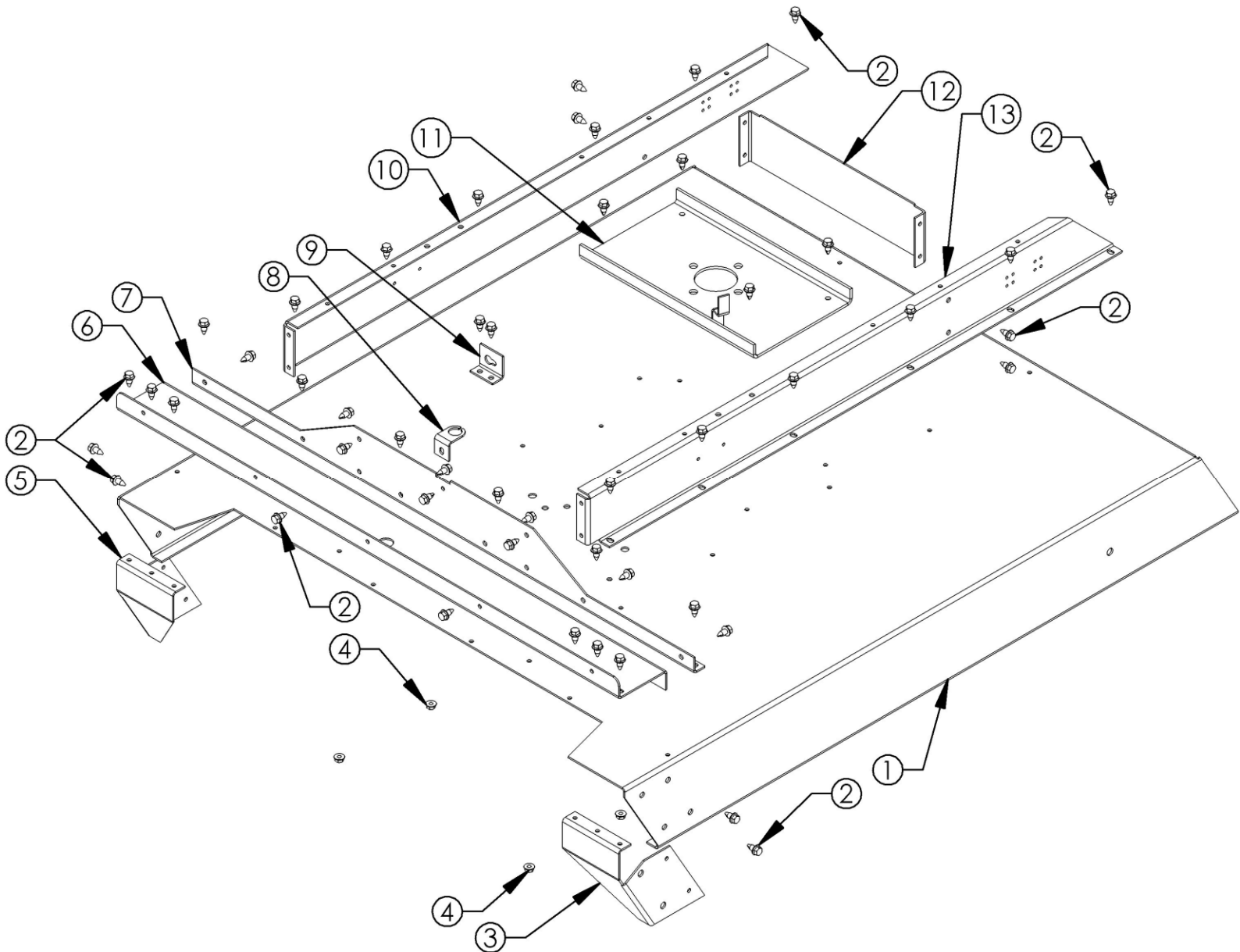

When ordering replacement parts
 * = USE PAINT CODE: TK=BLACK

BLADE DRIVER ASSEMBLY

FIGURE 7

Item #	Description	Part #
1	Nut - Nyloc 1"-8	NB612
2	Washer - 1" X 2" X 14GA	NB738
3	Pulley - Blade, 10.3125"	4846
4	Spacer - Pulley	19822
5	Bearing - Blade	4845
6	Shaft - Blade	18844
7	Nut - Nyloc 1/2"-13	NB281
8	Washer - USS Flat, 1/2"	NB555
9	Blade Driver Housing	4858*
10	Bolt - 1/2"-13 X 2"	NB509
11	Washer - 1" X 1 1/2" X 10GA	NB614HT
12	Nut - Nyloc 3/4"-10	NB609
13	Weldment - Stump Jumper	4859*
14	Blade	10358
15	Washer - 3/4" X 1 1/4" X 18GA	NB179
16	Bolt - 3/4"-10 X 2"	11431
17	Nut - Nyloc 1"-14	18850
18	Kit - Replacement, Blade Driver	18905

Note: The pulley, stump jumper, blades, blade hardware and housing hardware are not included with the 18905 replacement blade driver kit.

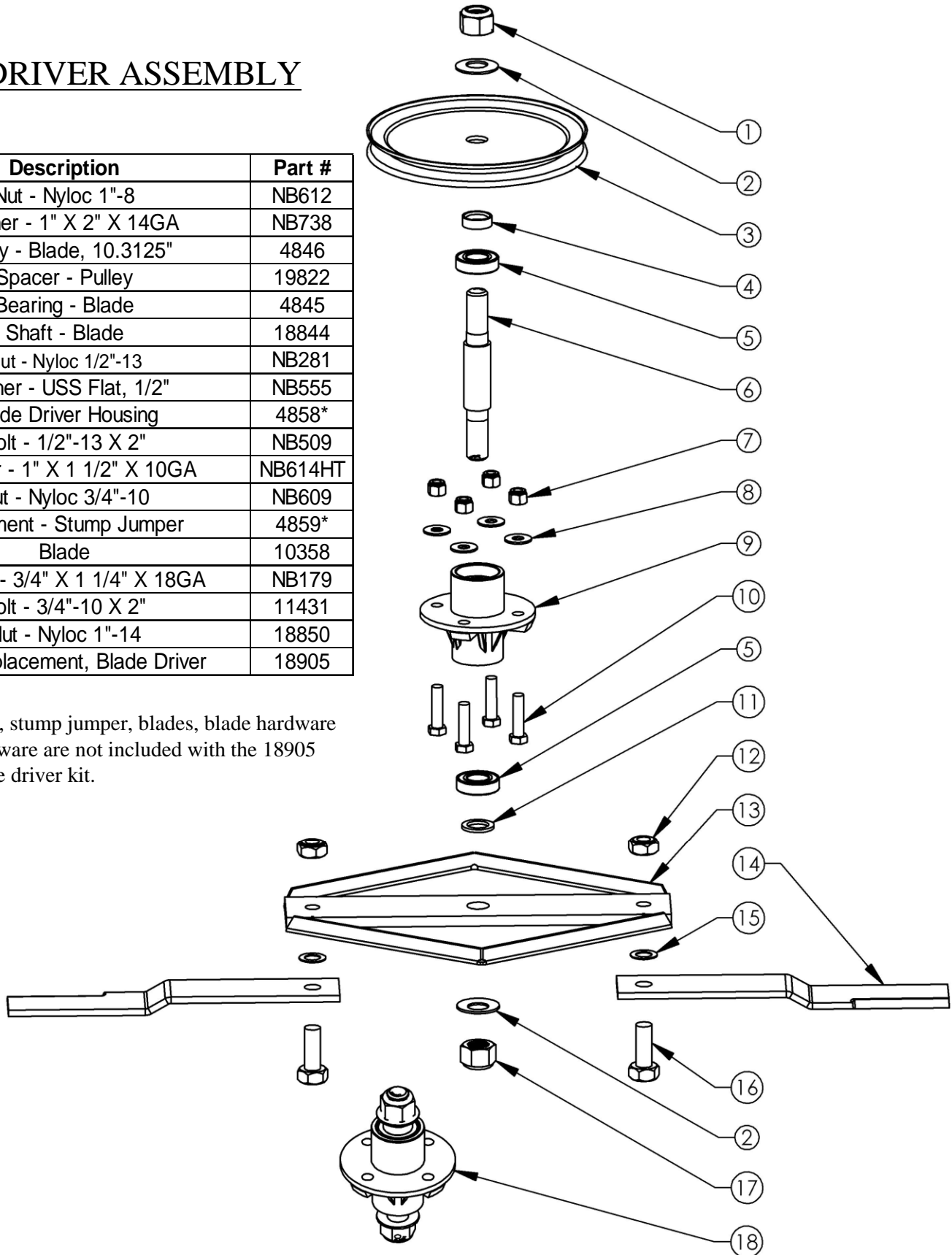

ENGINE PULLEY ASSEMBLY

FIGURE 8

Item #	Description	Part #
1	Engine B&S	N/A
2	5/16"-18 X 1 1/4" Serrated Flange Bolt	NB253
3	5/16-18 Serrated Flange Nut	NB170
4	5/16"-18 Nyloc Nut	NB181
5	Bolt - Serr Flange, 5/16-18 X1 3/4 ZY Gr5	NB515
6	Spacer For Engine Pulley	BB105S
7	1/4" X 1" Key Stock	9031
8	Engine Pulley- 4.25"OD,1 1/4" ID	BB105
9	Spacer Lower For Engine Pulley	BB105SL
10	Washer	TR150W
11	Washer Belleville Engine Pulley	699
12	7/16"-20 X 1 HCF GR5 ZP	NB452N
13	Oil Drain Valve	16000
14	RT44 Belt Guide	4867
15	5/16" USS Flat Washer ZP	NB556
16	Nut - Lock, 5/16-18	NB558

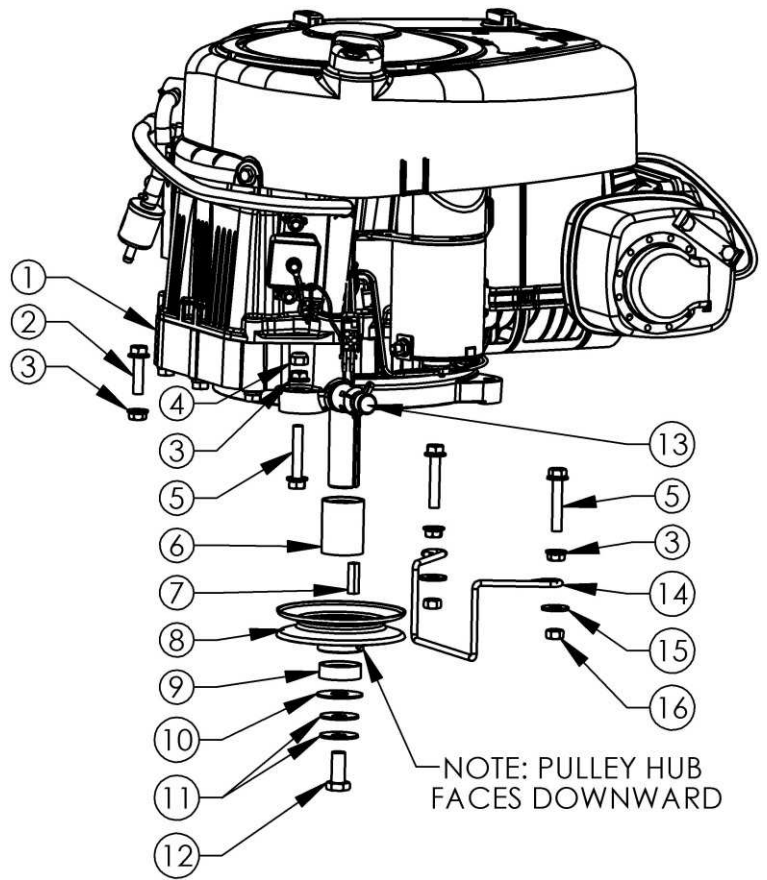

BELT ENGAGE CONFIGURATION

FIGURE 9

Item #	Description	Part #
1	1/2"-13 X 2 1/2" HCC GR5 ZP	NB510
2	Idler Arm	6681*
3	1/2"-13 2-Way Jam Lock Nut	NB121
4	1/4"-20 Nylok Nut	NB180
5	1/4"-20 X 3/4" GR5 ZP	NB250
6	Clutch Cable Clevis	9023MOD
7	1/4"-20 X 1" HCC GR5 ZP	NB102
8	Belt Engage Arm	4898*
9	1/4" SAE Washer	NB274
10	5/64" X 3/4" Cotter Pin	NB519
11	3/8"-16 Nyloc Nut	NB182
12	3/8" SAE Washer	NB272
13	1/2" X 1-9/16" Shoulder Bolt	NB220
14	Idler Pulley OD-3.25", ID-3/8"	B527
15	Brake Arm Assembly	4893
16	Torsion Brake Spring	9040
17	3/8"-16 HNC GR2 ZP	NB212
18	Clutch Rod Spring	682S
19	3/8" Hardened Washer	NB196
20	3/8"-16 X 2 1/2" HTC GR5 ZP	NB619
21	Washer Belleville	699
22	3/8-16 Nyloc Nut	NB182
23	1/4"-20 HX Nut ZP	NB139
24	Brake Rod	4891*
25	5/16"-18 X 1" HCC GR5 ZP	NB501
26	Spacer	B99S
27	5/16"-18 Nyloc Nut	NB181

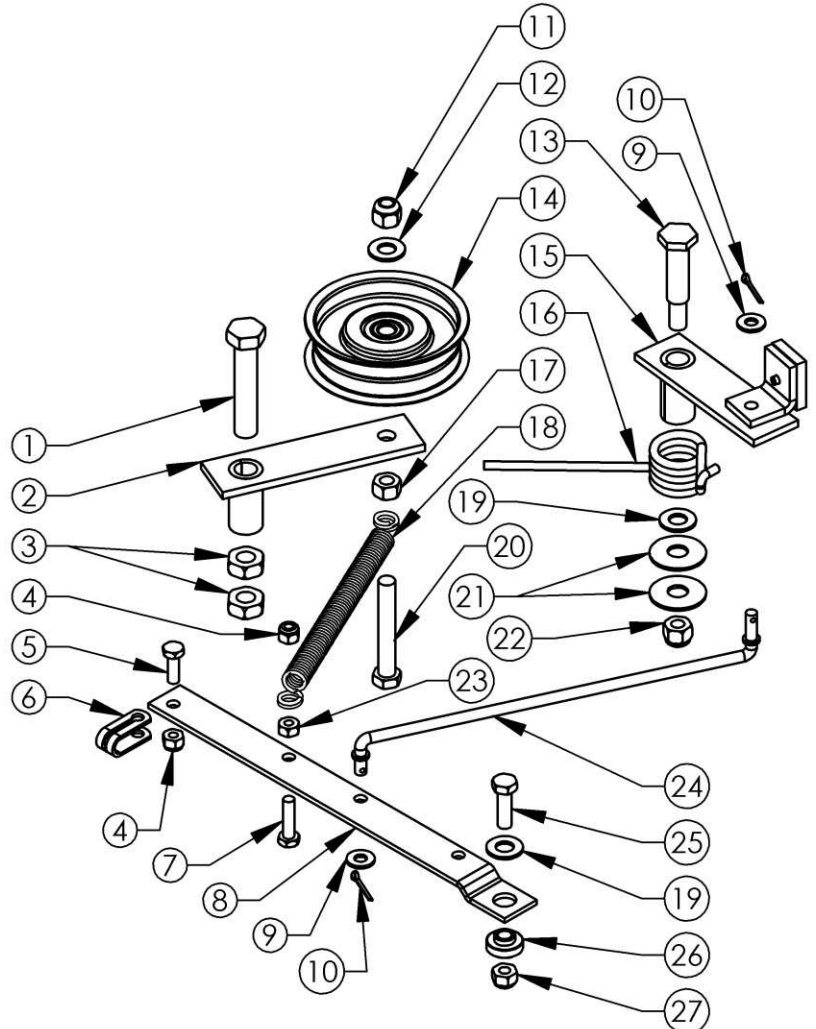

When ordering replacement parts

* = USE PAINT CODE: TK=BLACK

CONSOLE ASSEMBLY

FIGURE 10

Item #	Description	Part #	Item #	Description	Part #
1	T Handle for Console	4463*	11	1/4 SAE Washer	NB274
2	1/4-20 Nyloc Nut	NB180	12	1/4-20 X 2 1/2 HCC GR2 ZP	NB163
3	5/16-18 Nyloc Nut	NB181	13	1/4-20 X 1 1/4 HCC GR5 ZP	NB560
4	5/16-18 X 1 1/2 Bolt	NB505	14	Link for Console	4461*
5	Console Weldment	4575*	15	5/64 X 3/4 Cotter Pin	NB519
6	Key Switch Lock Washer	9088	16	Clutch Cable Clevis	9023MOD
7	Key Switch Nut	9087	17	1/4 X 1 1/2 Clevis Pin	NB518
8	Keys	KSK	18	Engage Cable	18817
9	Key Switch	3623	19	Wiring Harness, 11.5HP Engine	19193
10	Console Mount Plate	4852*	20	1/4-20 Wing Nut ZP	NB608

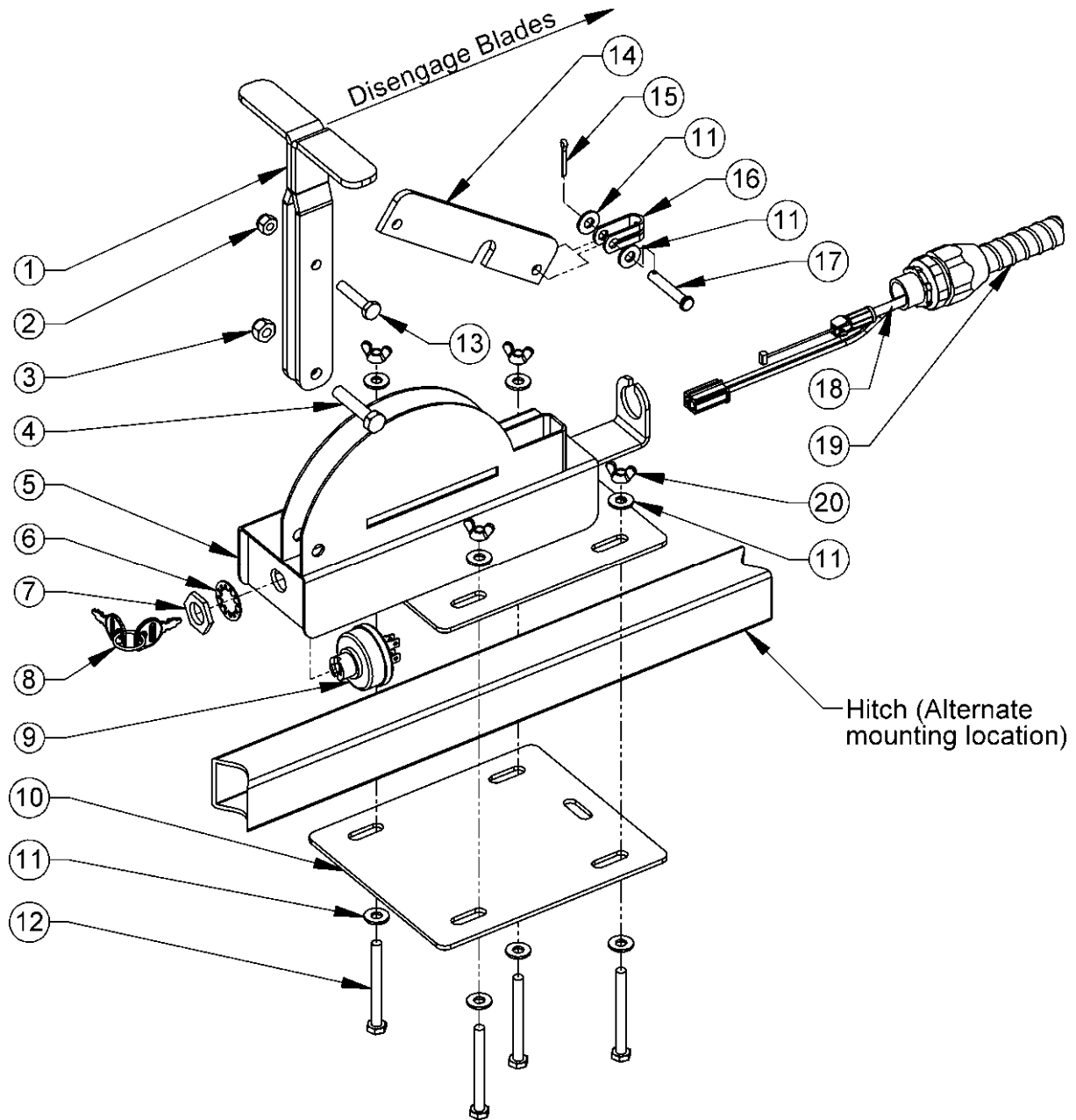

When mounting the console assembly it may be necessary to mount it directly to the hitch tube depending on the vehicle you are towing it with. Some vehicle configurations will allow the console to be mounted to the vehicle (i.e. ATV rack). Place the console weldment (4575*) on top of the hitch tube and assemble the console mount plate (4852*) from underneath the hitch tube using the hardware provided. Make sure the wiring harness is secure and will not drag the ground. Periodically check to make sure all hardware is tight and the wiring harness is secure. NEVER operate this machine without the wiring harness being secure.

ENGINE TO BLADE PULLEY CONFIGURATION

FIGURE 11

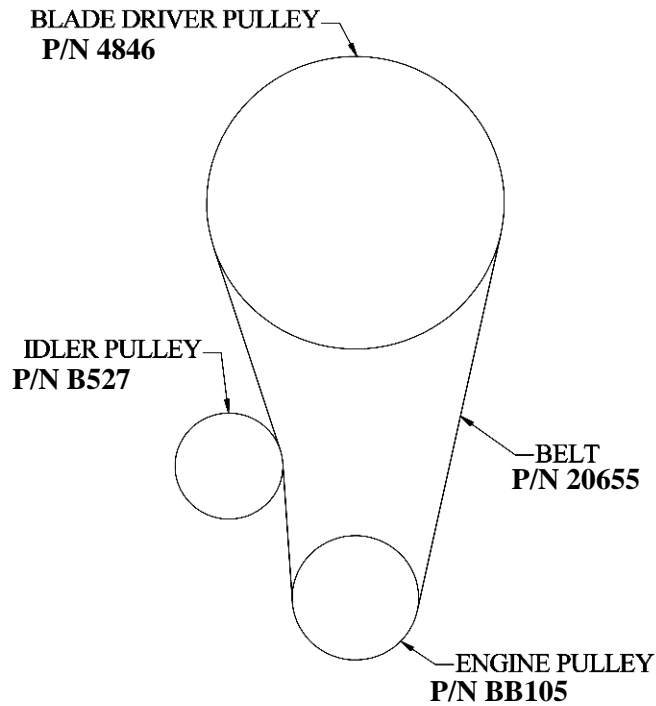

WIRING DIAGRAM

FIGURE 12
PN 19193

WIRING DIAGRAM, 11.5HP ENGINE

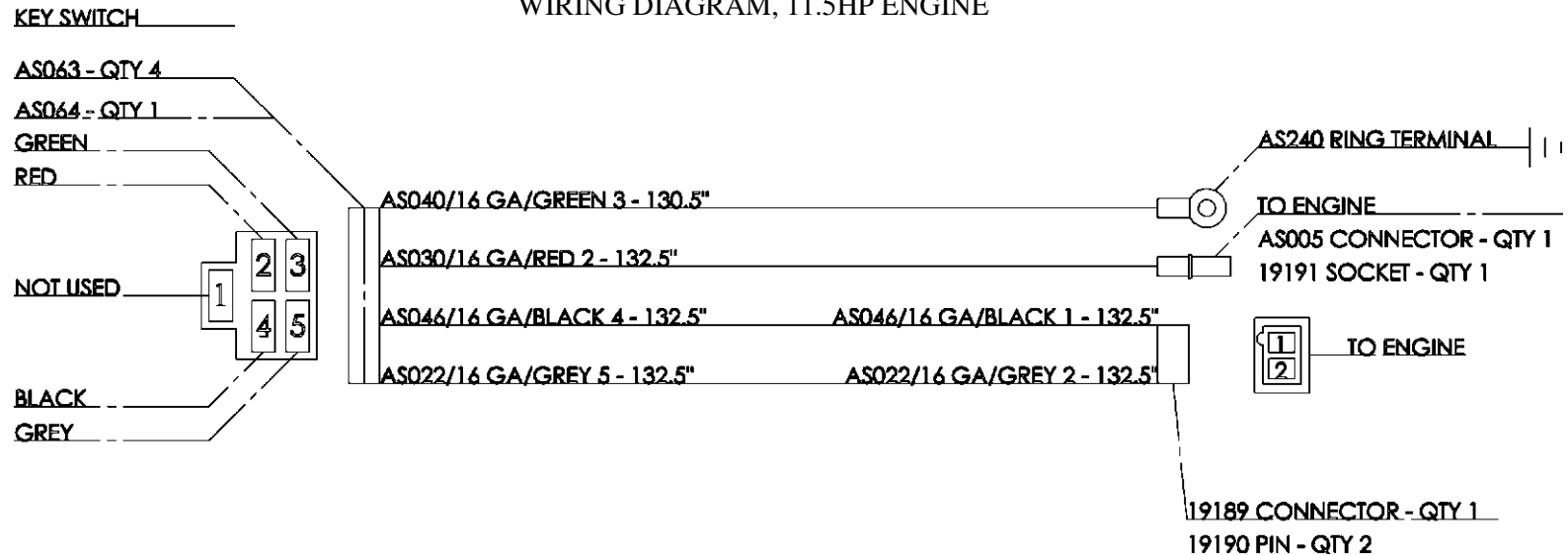

RECOMMENDED HITCH CONFIGURATIONS

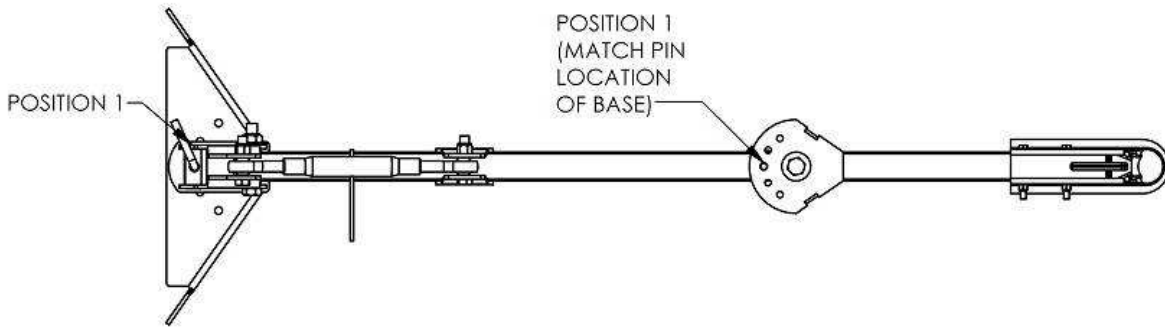

FIGURE 13

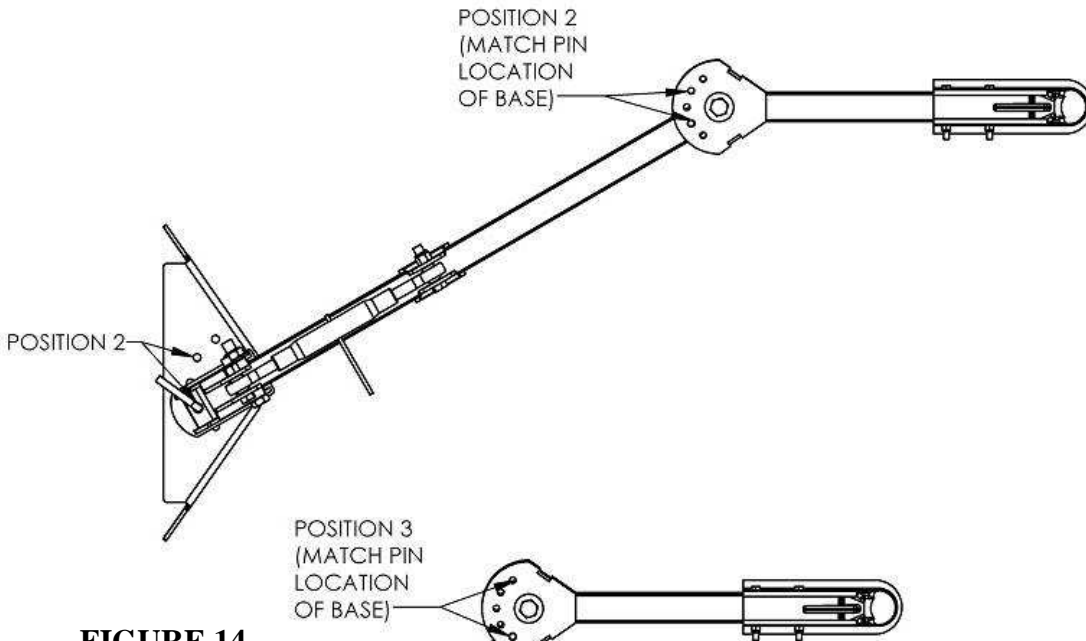

FIGURE 14

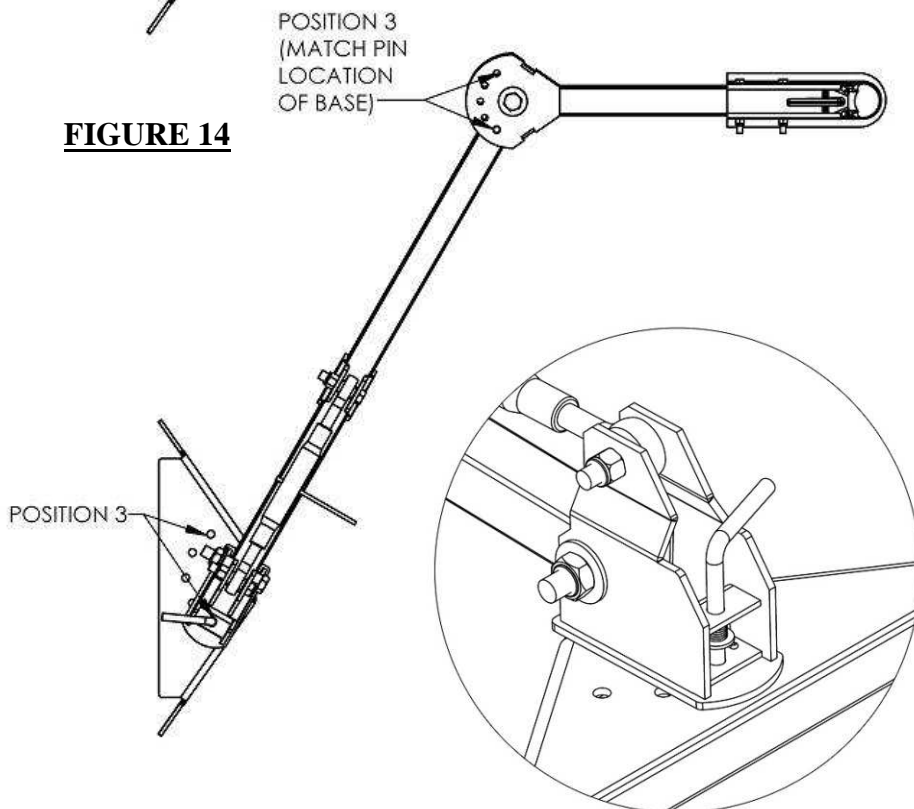

FIGURE 15

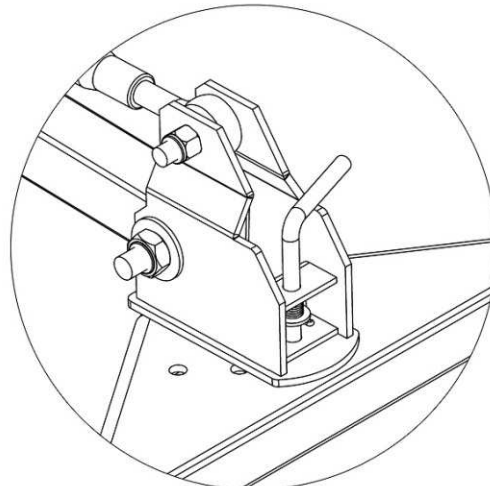

FIGURE 16
Unlocked

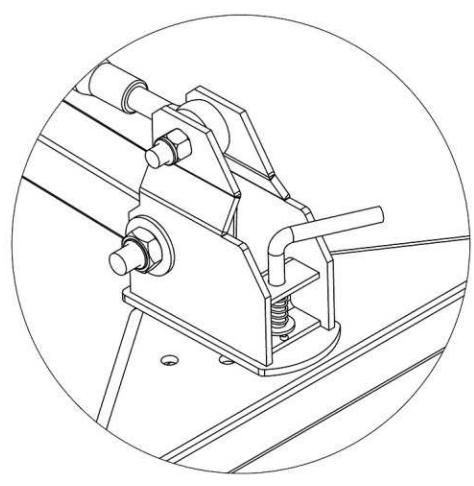
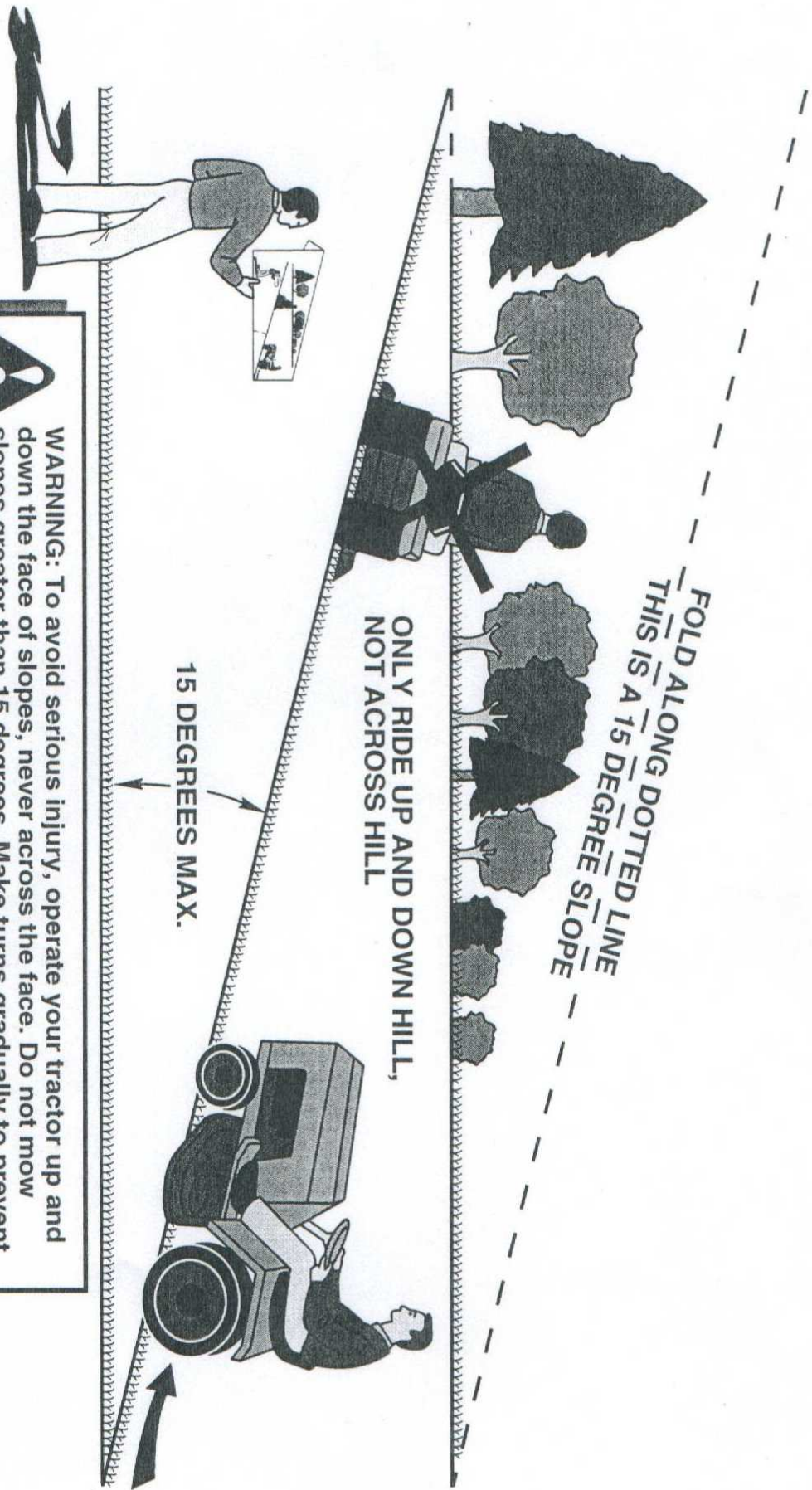

FIGURE 17
Locked

SUGGESTED GUIDE FOR SIGHTING SLOPES FOR SAFE OPERATION



FOLD ALONG DOTTED LINE
THIS IS A 15 DEGREE SLOPE

ONLY RIDE UP AND DOWN HILL,
NOT ACROSS HILL

15 DEGREES MAX.

**WARNING:** To avoid serious injury, operate your tractor up and down the face of slopes, never across the face. Do not mow slopes greater than 15 degrees. Make turns gradually to prevent tipping or loss of control. Exercise extreme caution when changing direction on slopes.

1. Fold this page along dotted line indicated above.
2. Hold page before you so that its left edge is vertically parallel to a tree trunk or other upright structure.
3. Sight across the fold in the direction of hill slope you want to measure.
4. Compare the angle of the fold with the slope of the hill.

www.swisherinc.com

OWNER'S MANUAL

MODEL NO.

RC11544BS



IMPORTANT

Read and follow all
Safety Precautions
and Instructions
before operating this
equipment.

44" COUNTRY CUT TRAIL CUTTER

Each mower has its own model number. Each engine has its own model number. The model number for the mower will be found on the right hand side of the motor mount. The model number for the engine will be found on the top of the valve cover.

All mower parts listed herein may be ordered directly from Swisher or your nearest Swisher dealer.

All engine parts may be ordered from the nearest dealer of the engine supplied with your mower.

WHEN ORDERING PARTS, PLEASE HAVE THE FOLLOWING INFORMATION AVAILABLE:

- * PRODUCT - RC44" COUNTRY CUT TRAIL CUTTER
- * SERIAL NUMBER - _____
- * MODEL NUMBER - _____
- * ENGINE MODEL NUMBER - _____
- TYPE - _____
- * PART NUMBER
- * PART DESCRIPTION

TELEPHONE - 1-800-222-8183

FAX - 1-660-747-8650

SWISHER ACQUISITION INC.

1602 CORPORATE DRIVE

WARRENSBURG, MO 64093

www.swisherinc.com

SWISHER®

CHANGING YOUR LANDSCAPE SINCE 1945