



## Hand Crank Hose Reel Instruction Manual

---



### **WARNING:**

Read carefully and understand all **INSTRUCTIONS** before operating. Failure to follow the safety rules and other basic safety precautions may result in serious personal injury. Save these instructions in a safe place and on hand so that they can be read when required. Keep these instructions to assist in future servicing.

---



## GENERAL SAFETY REGULATIONS



**WARNING:** The warnings, cautions, and instructions discussed in this instruction manual cannot cover all possible conditions or situations that could occur. It must be understood by the operator that common sense and caution are factors that cannot be built into this product, but must be supplied by the operator.

1. Keep the work area clean and dry. Damp or wet work areas can result in injury.
2. Keep children away from work area. Do not allow children to handle this product.
3. Use the right tool for the job. Do not attempt to force small equipment to do the work of larger industrial equipment. There are certain applications for which this equipment was designed. It will do the job better and more safely at the capacity for which it was intended. Do not modify this equipment, and do not use this equipment for a purpose for which it was not intended.
4. Check for damaged parts. Before using this product, carefully check that it will operate properly and perform its intended function. Check for damaged parts and any other conditions that may affect the operation of this product. Replace damaged or worn parts immediately.
5. Do not overreach. Keep proper footing and balance at all times to prevent tripping, falling, back injury, etc.
6. DO NOT use the equipment when tired or under the influence of drugs, alcohol, or medication. A moment of inattention while operating this equipment may result in serious personal injury

## TECHNICAL DETAILS

Item No.	Max Pressure	Inlet/Outlet	Hose Capacity		
			Material	I.D.	Length
L201303	300Psi (20Bar)	3/8"/9.5mm	Hose is not included	3/8"/9.5mm	30m/100ft
L201602	300Psi (20Bar)	1/4"/6.3mm	Hose is not included	1/4"/6.3mm	60m/200ft
H201303	4000Psi (275Bar)	3/8"/9.5mm	Hose is not included	3/8"/9.5mm	30m/100ft
H201602	4000Psi (275Bar)	1/4"/6.3mm	Hose is not included	1/4"/6.3mm	60m/200ft
L202153	300Psi (20Bar)	3/8"/9.5mm	Hose is not included	3/8"/9.5mm	15m/50ft
L202302	300Psi (20Bar)	1/4"/6.3mm	Hose is not included	1/4"/6.3mm	30m/100ft
H202153	4000Psi (275Bar)	3/8"/9.5mm	Hose is not included	3/8"/9.5mm	15m/50ft
H202302	4000Psi (275Bar)	1/4"/6.3mm	Hose is not included	1/4"/6.3mm	30m/100ft

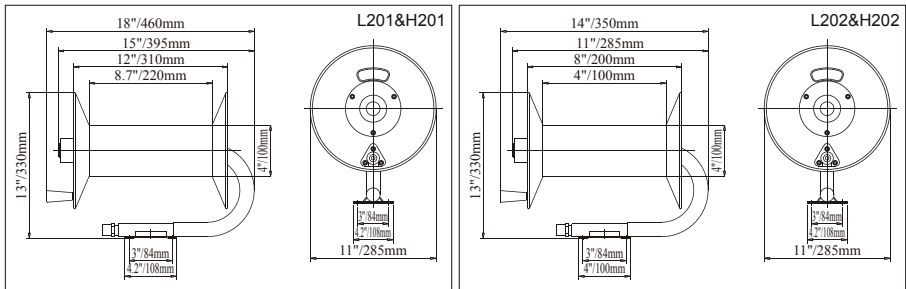

Read the following precautions and instructions before you begin assembly or using. Keep this literature in a dry place for future reference.

## SAFETY PRECAUTIONS

1. Make sure input pressure does not exceed 300 PSI / 20Bar (L201 & L202) or 4000 PSI / 275Bar (H201 & H202).
2. Use the proper eye protection when assembling and using the hose reel.
3. Assemble the hose reel on a clean workbench free of debris and moisture.
4. Use soap and water when checking for air leaks.
5. Do not expose fingers or hands directly to a pressurized hose, or it will result in severe body injury.
6. Keep children away from the work area.

## UNPACKING

When you receive your new Hose Reel, it will be mostly reassembled. Check to ensure that you have received the following loose parts.

Part No.	Description	Q'ty
20	Screw	3
21	Washer	3
22	Nut	3
23	Handle	1

## INSTALLATION

**Note:** You must purchase hardware & hose for mounting your new reel. Decide where you wish to mount reel before purchasing as the hardware needed will vary provided different locations.

### Refer To Appendix For Assembly

1. Match handle to 3 holes in reel flange. Attach using 3 screws, nuts and washers.

**Note:** Nuts must go on handle side of flange.

2. Put the bolts (3/8" or 10mm) through 4 holes in the base of the hose reel and tighten it to ceiling/wall/floor so reel can be fastened into position.
3. Apply teflon tape or thread sealant to reel's built in supply hose fitting. Then attach this supply hose to the outlet of air compressor.
4. Apply teflon tape or thread sealant to hose fitting threads. Attach to the reel swivel valve, then feed the rest of hose through the flange opening.

5. To avoid damaging the swivel valve, make sure to use a appropriate wrench to stabilize the swivel hosing tightening the hose fitting.
6. For the length of hose, please refer to TECHNICAL DETAILS on page 3.

## 201 & 202 EXPLODED AND PARTS LIST

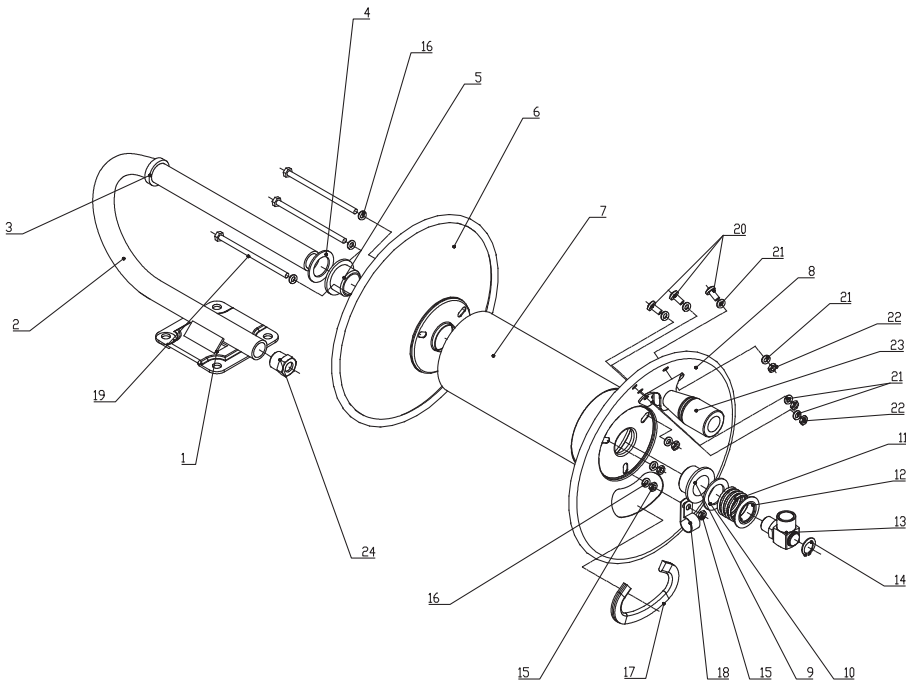

Part No.	Description	Q'ty	Part No.	Description	Q'ty
1	Base(welded with stand)	1	13	Swivel (including 2 valve & 2 O-ring)	1
2	Stand(steel pipe covered with foam protector)	1	14	Spring wahser	1
3	Fixed washer (welded on stand)	1	15	Nut	3
4	Washer	1	16	Washer	3
5	Positon sleeve	1	17	Protector (rubber)	1
6	Flange A	1	18	Clamp	1
7	Sleeve	1	19	Screw	3
8	Flange B	1	20	Screw	3
9	Position sleeve	1	21	Washer	3
10	Washer	1	22	Nut	3
11	Spring	1	23	Handle	1
12	Washer	1	24	Valve	1

The Reel Expert  
**ReelWORKS®**

Intradin (Shanghai) Machinery Co., Ltd.  
iti-fluid@intradinchina.com  
www.intradin.com

E2