

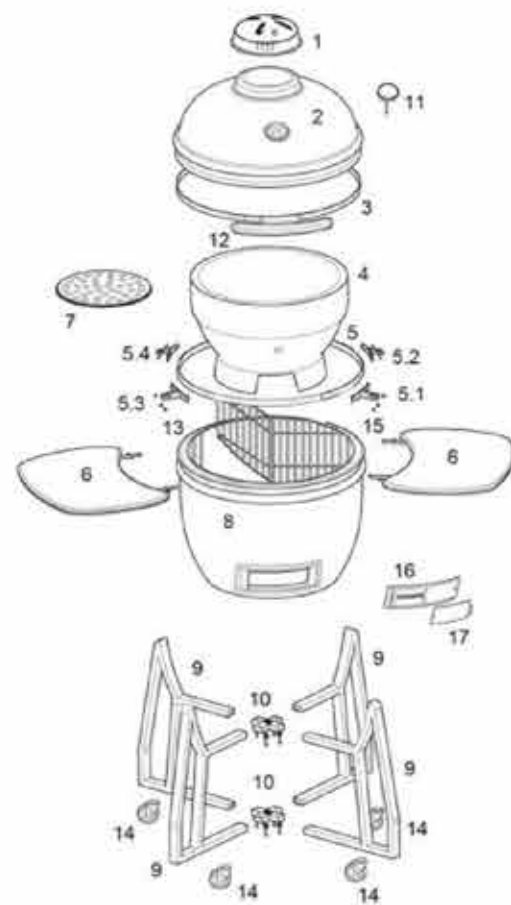

Questions, problems, missing parts? Contact technical support department at 657-341-0362, 9:00 a.m. - 5 p.m., PST, Monday - Friday or visit us online at www.lonestarchef.com



Part Names

1. Top Vent
2. Ceramic Dome Top Top
3. Ring Assembly
4. Fire Bowl
5. Bottom Ring Assembly
- 5.1 Right Front Side Shelf Bracket
- 5.2 Right Back Side Shelf Bracket
- 5.3 Left Front Side Shelf Bracket
- 5.4 Left Back Side Shelf Bracket
6. Wood Shelves (x2)
7. Charcoal Grate
8. Ceramic Dome Bottom
9. Tubular Legs (x4) Straight
10. X Leg Connector and Washers (x2)
11. Thermometer
12. Handle
13. Cooking Grid
14. Rubber Wheels (x4) Small
15. Felt Gasket
16. Bottom Draft Door Frame
17. Bottom Draft Door

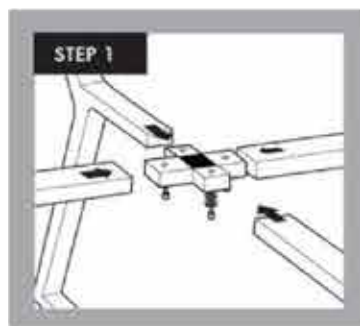

Step 1: Cart Assembly

First remove the bolts, washers, and spring washers from the two "X" connectors carefully. Remove the paper washers and then begin the assembly for the "X" connectors and legs. Flip cart upside down for easy assembly. Assemble cart by inserting two "X" connectors into leg ends, then screw in using the wrench provided. Place lock washer above flat washer over bolt before screwing through leg into "X" connector. Screw in casters and tighten nuts using wrench provided. While assembling, leave screws loose to allow adjustment in cart. Otherwise it can be difficult to get all of the screws in. After cart is assembled, confirm all bolts are tightened, then lift Kamado and set into cart with bottom vent centered between the two legs.

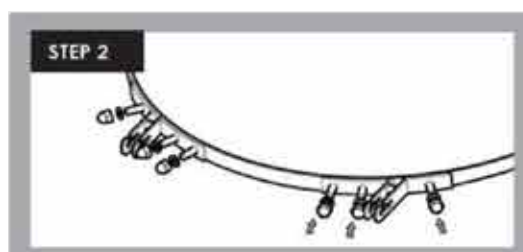

Step 2: Shelf Bracket

Remove the nuts and washers from the bolts welded on the bottom banding carefully. Remove the paper washers. Place the side brackets on the bolts and screw side brackets down tightly with the nuts and washers. Mount shelf brackets over studs on the sides of the metal bands on the bottom ceramic grill body with bracket slots facing up. Brackete are stamped on the back with letters indicating their position (e.g., LF=Left Front bracket and RB=Right Back bracket). Mount flat washer then acorn nut on each stud and tighten with wrench provided.

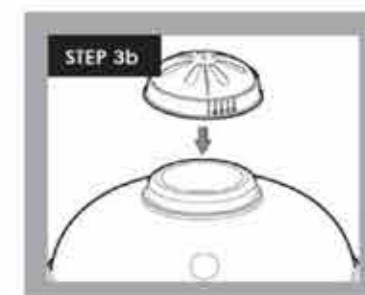

Step 3: Grill Assembly

Take all parts out of grill before lifting. The grill is heavy and will require 2 people to lift it onto the cart and if possible a third person to help guide the kamado centering in the cart. Using the shelf brackets as lift handles, lift grill and set it into cart. Place fire bowl inside the kamado. Place cast iron grate into fire bowl. Place cooking grate onto grill with hinged section facing towards front of grill. Close lid and press top vent onto top of kamado so spring clips are fully engaged, with calibrations facing the front of the grill.

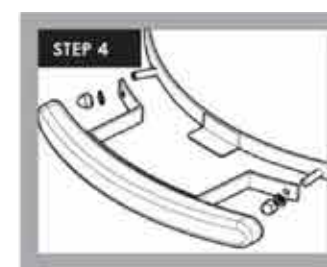

Step 4: Handle and Side Shelf Mounting

Remove the nuts and washers from the bolts welded on the top banding carefully. Remove the paper washers, place the handle on the bolts, and tightly screw the handle down using the nuts and washers. Attach the handle by placing handle bracket over studs, opposite the hinge. On each stud use flat washer, then screw on acorn nut and tighten. Mount side shelves by inserting the shelf rod into the shelf bracket, Tilting the shelf up slightly and sliding in or out allows you to deploy or store the shelves.

Step 5: Long-Term Maintenance

1. The Wood Side Shelves should be covered when not in use and may require refinishing wax from time to time.
2. Routinely check the Spring Assist Band to make sure the 2 5/8" bolts are tight and secure.