



Digital oil control valve Instruction Manual



WARNING:

Read carefully and understand all **INSTRUCTIONS** before operating. Failure to follow the safety rules and other basic safety precautions may result in serious personal injury. Save these instructions in a safe place and on hand so that they can be read when required. Keep these instructions to assist in future servicing.



GENERAL SAFETY REGULATIONS



WARNING: The warnings, cautions, and instructions discussed in this instruction manual cannot cover all possible conditions or situations that could occur. It must be understood by the operator that common sense and caution are factors that cannot be built into this product, but must be supplied by the operator.

1. Keep the work area clean and dry. Damp or wet work areas can result in injury.
2. Keep children away from work area. Do not allow children to handle this product.
3. Use the right tool for the job. Do not attempt to force small equipment to do the work of larger industrial equipment. There are certain applications for which this equipment was designed. It will do the job better and more safely at the capacity for which it was intended. Do not modify this equipment, and do not use this equipment for a purpose for which it was not intended.
4. Check for damaged parts. Before using this product, carefully check that it will operate properly and perform its intended function. Check for damaged parts and any other conditions that may affect the operation of this product. Replace damaged or worn parts immediately.
5. Do not overreach. Keep proper footing and balance at all times to prevent tripping, falling, back injury, etc.
6. DO NOT use the equipment when tired or under the influence of drugs, alcohol, or medication. A moment of inattention while operating this equipment may result in serious personal injury

TECHNICAL DETAILS

Item No.	18123522G
Inlet	1/2" BSP / NPT
Configure	Flexible nozzle, auto tip
Flow Rate	1-35L/min / 0.3~9.2gpm
Operating Pressure Range	0.5-100bar / 7-1500psi
Max Operation Temperature	60°C / 140°F
Accuracy	±0.5%
Battery	ER14250 3.6V

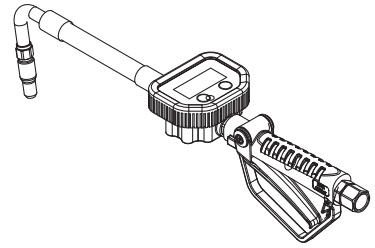

! This manual contains important warnings and information. Read and keep for reference.

! **Warning Symbol**
This symbol alerts you to the possibility of serious injury or death if you do not follow the instructions.

! **Caution Symbol**
This symbol alerts you to the possibility of damage to or destruction of equipment if you do not follow the instructions.

SAFETY PRECAUTIONS

EQUIPMENT MISUSE HAZARD

1. This equipment is for professional use only.
2. Read all instruction manuals, tags, and labels before operating the equipment.
3. Use the equipment only for its intended purpose. If you are not sure, call your distributor.
4. Do not alter or modify this equipment.
5. Check equipment daily. Repair or replace worn or damaged parts immediately.
6. Do not exceed the maximum working pressure of the lowest rated system component. This equipment has a 1500psi (10Mpa, 100bar) maximum working pressure.
7. Use fluids and solvents which are compatible with the equipment wetted parts. Refer to the Technical Data section of all equipment manuals. Read the fluid and solvent manufacturer's warnings.
8. Route hose away from traffic areas, sharp edges, moving parts, and hot surfaces.
9. Do not lift pressurized equipment.
10. Comply with all application local, state, and national fire, electrical, and safety regulations.

INJECTION HAZARD

Spray from the valve, leaks or ruptured components can inject fluid into your body and cause extremely serious injury, including the need for amputation. Fluid splashed in the eyes or on the skin can also cause serious injury.

1. Fluid injected into the skin might look like just a cut, but it is a serious injury. Get immediate medical attention.
2. Do not point the valve at anyone or at any part of the body.
3. Do not put your hand or fingers over the grease fitting coupler.
4. Do not stop or deflect leaks with your hand, body, glove or rag.
5. Tighten all fluid connections before operating the equipment.
6. Check the hose, tubes, and couplings daily. Replace worn or damaged parts immediately. Do not repair high pressure couplings; you must replace the entire hose.

INSTALLATION

Typical Installation

Fig. 1 shows a typical installation.

The installation shown in Fig. 1 is only a guide. The components shown are typical; however, it is not a complete system design. Contact your distributor for assistance in designing a system to suit your particular needs.

Pre-Installation Procedure

1. Relieve the pressure.

To reduce the risk of serious injury whenever you are instructed to relieve pressure, always follow the pressure relief procedure on page 3.

1. Close the fluid shut-off valve (Item 4 in Fig. 1)
2. Ground the hose and reel or console. Do not use PTFE tape on the pipe joints; it may cause a loss of ground across the pipe joint.

Installation Procedure

If this is a new installation, or if the oil in the lines is contaminated, flush the lines before you install the dispense valve.

- 1: Air inlet
- 2: Air shut-off valve
- 3: Oil pump
- 4: Fluid shut-off valve
- 5: Meter
- 6: Hose reel
- 7: Control valve

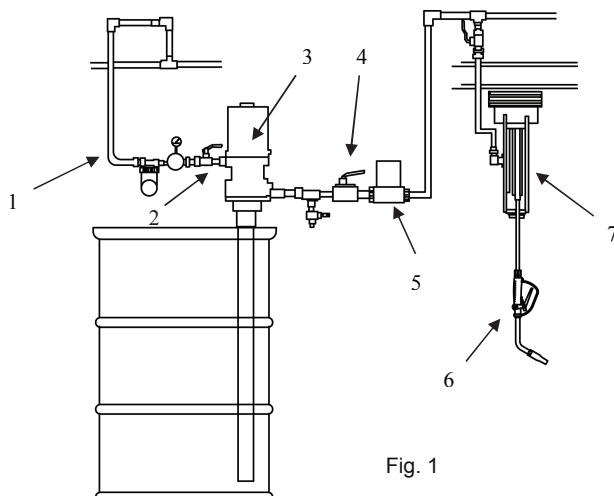

Fig. 1

NEW INSTALLATION

1. Relieve the pressure

To reduce the risk of serious injury whenever you are instructed to relieve pressure, always follow the pressure relief procedure on page 3.

2. Close the fluid shut-off valve at each dispense position.
3. Make sure the main fluid outlet valve at the pump is closed, the air pressure to the pump motor is adjusted, and the air valve is open. Slowly open main fluid valve.
4. Place the hose end (with no dispense valve connected) into a container for waste oil. Secure the hose in the container so it will not come out during flushing. If you have multiple dispense positions, first flush the dispense position farthest from the pump, and work your way toward the pump.
5. Slowly open the shut-off valve at the dispense position. Flush out a sufficient amount of oil to ensure that the entire system is clean, and close the valve.
6. Repeat step 5 at all other dispense positions.

- 1: Trigger
- 2: Nozzle
- 3: Tip
- 4: Swivel nut

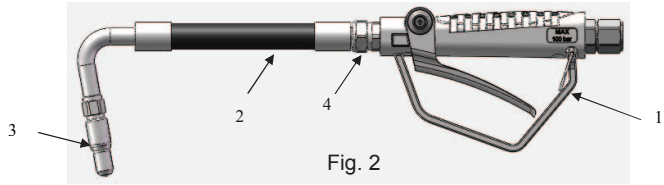

Fig. 2

Remark: If you want to adjust the angle of the nozzle, you can loose the #4 swivel nut, then turn thenozzle to your desired position and tighten the nut.

Existing Installation

1. Relieve the pressure
To reduce the risk of serious injury whenever you are instructed to relieve pressure, always follow the pressure relief procedure on page 3.
2. Loosen and disconnect the hose from the old dispense valve (the one that you are replacing)
3. Thread the extension into the outlet of the dispense valve, and tighten firmly. **NOTE:** Do not over tighten the extension tube assembly by using the nozzle adapter to hand turn the nozzle. For rigid extensions, thread the extension in at least three full turns, position the extension for proper alignment, and tighten the sealing nut. The PTFE seal on the sealing nut must face the valve housing.
4. Apply thread sealant to the male threads of the hose fitting, thread the hose fitting into the swivel, and tighten firmly.
5. Thread the new nozzle or nozzle adapter onto the extension, and tighten firmly.
6. Open all dispense position shut-off valves, and start the pump to pressurize the system. See the Operation section for proper operation.
7. For metered dispense valves, to ensure dispensing accuracy, purge all air from the fluid lines and dispense valves before you use them.

Grounding

Proper grounding is an essential part of maintaining a safe system.

To reduce the risk of static sparking, ground all system components per local and national electrical codes.

Refer to the user manuals for the pump and other system components to ground the following:

- Pump: Follow manufacture's recommendations.
- Air and Fluid hoses: Use only grounded hoses.
- Air compressor: Follow manufacture's recommendations
- Fluid supply container: Follow your local code.
- To maintain grounding continuity when flushing or relieving pressure, always hold a metal part of the valve firmly to the side of a grounded metal pail, then trigger the valve.

OPERATION



CAUTION

- Never operate the meter with the plastic cover removed. The cover protects the meter from damage due to impact. Meters are factory sealed to keep moisture and dirt out.
- To prevent line contamination, which can cause equipment malfunction or damaged, flush the lines before you install this equipment in the system.

Display and Button Usage

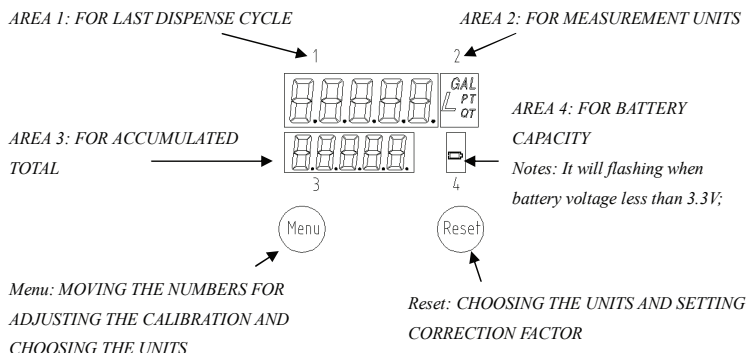

To Activate the Digital Display

Press the RESET key pad to clear the meter before starting a new dispense cycle. This is the best way to activate the meter, because it also clears the quantity of the last dispense cycle. The digital display can also be activated by pressing the MENU key pad or by running fluid through the meter.

Calibrating Automatically

- Press Reset key for 1 second and Area 1 shows .000 L;
- Keep running fluid through the meter until the fluid running out of the certain measuring cylinder. The display will show certain value as ****L**, press the Menu key for 3 seconds. The meter will enter instrument calibration mode and Area 1 shows **00**L**;
- Press Menu key to move the flashing digital, press Reset key to choose number, enter the fluid volume and press Menu key again for 3 seconds, then exit the calibration mode. The calibration settled

Show Current Correction Factor

- Press Menu key and Reset key together. The display will show the correction factor, which can be reset

Reset The Resettlement Total

- Press Menu key for 10 seconds, the accumulated total will be reset to be "0"

To Change the Measurement Units (L / GAL/ PT / QT meter only)

- Move the flashing display to Area 2 by pressing Menu key, then press Menu key to choose measurement unit
- Press Menu key over 3 seconds to exit the setting mode



CAUTION

- To be sure the proper amount of fluid is dispensed, always use the same measurement unit for a particular fluid. Units should be changed only by authorized employees.
- To Verify the Accuracy of an Digital Meter
- Use a clean, calibrated container. If using a single container, be sure to clean it after each dispense.
- Have pump air pressure at the lowest possible setting for dispensing fluid.
- Put the tip of the nozzle at the bottom of the calibrated container.
- If the tip of the dispense valve does not reach the bottom of the calibrated container, use a length of plastic tubing over the tip of the nozzle to ensure liquid enters the container from the bottom.

- Trigger the gun slowly so the fluid immediately covers the tip of the dispense valve.

Pressure Relief Procedure

Pressurized Equipment Hazard

The equipment stays pressurized Fluid under high pressure can be injected through the skin and cause serious injury. To reduce the risk of an injury from injection, splashing fluid, or moving parts, follow the pressure relief procedure whenever you:

- Are instructed to relieve pressure,
- Check, clean or service any of the system equipment,
- Install or clean the nozzle.
 1. Turn off the power supply to the pump.
 2. Trigger the valve into a waste container to relieve pressure.
 3. Open any bleed-type master air valves and fluid drain valves in the system.
 4. Leave the drain valve open until you are ready to pressurize the system.

If you suspect that the dispensing valve, extension, or nozzle is clogged or that pressure has not been fully relieved after following the steps above, very slowly loosen a fitting on the fluid line to relieve pressure gradually, then loosen it completely, then clear the clog.

To reduce the risk of a serious bodily injury, including fluid injection, never exceed the maximum working pressure of the valve you are using or of the lowest rated component in your system.

Dispensing Procedure

Note: Before you begin, make sure you understand how to unlock the trigger.

1. Pull the trigger toward the valve body to open the valve and begin dispensing.
2. Lock the valve open by keeping the trigger squeezed and depressing the trigger lock button. Then release the trigger, releasing your forefinger from the trigger lock last.
3. Pull the trigger toward the valve body to release the trigger lock. The trigger lock disengages. Release the trigger to stop dispensing.

TROUBLE SHOOTING GUIDE

Relieve the pressure before you check or repair the dispensing valve. Be sure all other valves and controls and the pump are operating properly.

To reduce the risk of serious injury whenever you are instructed to relieve pressure, always follow the pressure relief procedure on page 3.

Problem	Problem	Solution
Slow or no fluid flow	Filter is clogged, or pump pressure is low, or shut-off valve is not fully open, or foreign materials jammed in the metering element.	1. Relieve the pressure. 2. Loose swivel fitting, clean or replace the filter. 3. If the problem remains, contact your distributor for repair or replacement.
Oil leaks from swivel	Swivel is loose	Torque the swivel If the problem remains, contact your distributor for repair or replacement
	O-ring is worn or damaged	Replace the o-ring. If the problem remains, contact your distributor for repair or replacement
Oil drips from nozzle	Nozzle is damaged or obstructed	Inspect the nozzle for damage or obstructions, and replace if damaged If the problem remains, contact your distributor for repair or replacement
Valve leaks	O-rings or valve seat are worn or damaged	Replace the o-rings and/or the valve seat. If the problem remains, contact your distributor for repair or replacement
Leakage from meter	O-ring damaged	1. Get the meter off from the dispense system 2. Take off the protector 3. Loosening four the socket head cap screws on the cover of the meter 4. Loosening eight the hex bolts on the bottom of the meter 5. Take off the seat 6. Check the o-ring, replacing the o-ring if it is damaged 7. After replacing the o-ring, assemble the meter and fix it back to the dispense system
No Display	Loosing Battery	1. Get the meter off from the dispense system 2. Take off the protector 3. Take off the labels sticks on the bottom of the meter 4. Loosening the five socket head cap screws on the bottom of the meter 5. Take off the seat 6. Check the battery, replacing the battery if it is out of power 7. After replacing the battery, assemble the meter and fix it back to the dispense system
	Battery out of power	
Wrong Reading	correction coefficient error	Reset the correction factor (follow the instructions on Page 6)

LIMITED WARRANTY

1. The manufacturer warrants this product against defects in material and craftsmanship, for a period of five years from date of purchase, but not including wearing parts.
2. Manufacturer's liability is limited to replacement or repair of defective material within the warranty period, when returned freight prepaid to the distributor or their designated service depot.
3. The warranty does not cover damage caused by accident, misuse or faulty installation.
4. The product must be installed and maintained in compliance with the instructions.

EXPLODED AND PARTS LIST

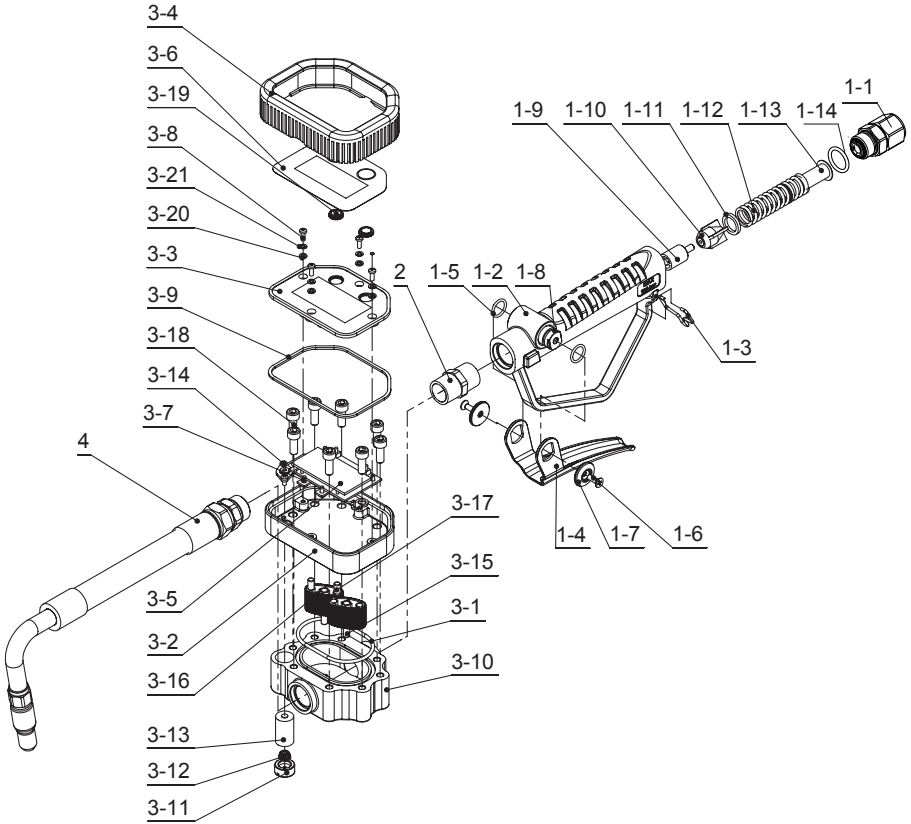

TECHNICAL
DETAILS

SAFETY
PRECAUTIONS

INSTALLATION

OPERATION

TROUBLE
SHOOTING GUIDE

LIMITED
WARRANTY

EXPLODED AND
PARTS LIST

Part No.	Description	Q'ty	Part No.	Description	Q'ty
1-1	Swivel	1	3-5	Main Circuit Board	1
1-2	Handle	1	3-6	Front Label	1
1-3	Trigger lock	1	3-7	Screw	4
1-4	Trigger	1	3-8	Screw	4
1-5*	O-ring	2	3-9	O-ring	1
1-6	Screw	2	3-10	Seat	1
1-7*	Washer, flat	2	3-11	Battery cover	11
1-8	Cam	1	3-12	Spring	1
1-9	Rod	1	3-13*	Battery	1
1-10*	Seat	1	3-14	Screw	2
1-11	Washer	1	3-15	Shaft	2
1-12	Spring	1	3-16	Oval Gear	2
1-13*	Filter	1	3-17	Magnetic Rod	2
2	Adapter	1	3-18	Bolt	8
3-1*	O-ring	1	3-19*	Waterproof protector	2
3-2	Meter Holder	1	3-20*	Seal washer	4
3-3	Meter Cover	1	3-21	Washer	4
3-4	Rubber Protector	1	4	Nozzle with tip	1

Item No.4 description:

Part No.	Description
MH10001	Rigid nozzle
MH10002	Flexible nozzle
MT10001	Manual tip
MT10002	Auto tip
MT10003	Semi-auto tip

Wearing parts:

Part No.	Description	Q'ty	Part No.	Description	Q'ty
1-5*	O-ring	2	3-9*	O-ring	1
1-7*	Washer, flat	2	3-13*	Battery	1
1-10*	Seat	1	3-19*	Waterproof protector	2
1-13*	Filter	1	3-20*	Seal washer	4
3-1*	O-ring	1			



Goodyear (and winged foot design) and Blimp are trademarks of The Goodyear Tire & Rubber Company used under license by Intradin (Shanghai) Machinery Co., Ltd. China.
Copyright 2016 The Goodyear Tire & Rubber Company.