



USER MANUAL



FOR MODELS:

GM6000iE/GM6000iED

Portable Inverter Generator

5250(GAS.)/4750(LPG) Running Watts | 6000(GAS.)/5500(LPG) Peak Watts

California

Proposition 65 Warning

The engine exhaust from this product contains chemicals known to the state of California to cause cancer, birth defects or other reproductive harm.

California

Proposition 65 Warning

Certain components in this product and its related accessories contain chemicals known to the state of California to cause cancer, birth defects or other reproductive harm. Wash hands after handling.

DISCLAIMERS:

All information, illustrations and specifications in this manual are based on the latest information available at the time of publishing. The illustrations used in this manual are intended as representative reference views only. Moreover, because of our continuous product improvement policy, we may modify information, illustrations and/or specifications to explain and/or exemplify a product, service or maintenance improvement. We reserve the right to make any change at any time without notice. Some images may vary depending upon which model is shown.

ALL RIGHTS RESERVED:

No part of this publication may be reproduced or used in any form by any means – graphic, electronic or mechanical, including photocopying, recording, taping or information storage and retrieval systems – without the written permission of CHONGQING DINKING POWER MACHINERY CO., LTD

DANGER



This manual contains important instructions for operating this inverter generator. For your safety and the safety of others, be sure to read this manual thoroughly before operating the generator. Failure to properly follow all instructions and precautions can cause you and others to be seriously hurt or killed.

TECHNICAL SPECIFICATIONS

Model Number	Running Watts	Peak Watts	Fuel Tank Size (Gal)	Rated Speed (RPM)	Ignition Type	Spark plug	Engine Disp (cc)	Stroke X Bore	Oil Capacity (Gal)	Oil Type
GM6000iE	5250	6000	3.5	3600	CDI	A5RTC	312	80×62	0.21	10W30
GM6000iED	5250(GAS.) 4750(LPG)	6000(GAS.) 5500(LPG)	3.8	3600	CDI	A5RTC	312	80×62	0.21	10W30

LIMITED WARRANTY

1. **DURATION** : One (1) year from the date of purchase by the original purchaser (retail customer) on products used solely for consumer applications; if a product is used for business, commercial, or industrial applications, the warranty period will be limited to ninety (90) days from the date of purchase.
 2. **WHO GIVES THIS WARRANTY (WARRANTOR):**
CHONGQING DINKING POWER MACHINERY CO., LTD
 3. **WHO RECEIVES THIS WARRANTY(PURCHASER):**
The original purchaser (other than for purposes of resale) of the Genmax' s inverter.
 4. **WHAT PRODUCTS ARE COVERED BY THIS WARRANTY:**
Any portable generator supplied or manufactured by Warrantor.
 5. **WHAT IS COVERED UNDER THIS WARRANTY:**
Substantial defects on material and workmanship which occur within the duration of the warranty period.
 6. **WHAT IS NOT COVERED UNDER THIS WARRANTY:**
 - A. Transportation charges for sending the product to Warrantor or its authorized service representative for warranty service, or for shipping repaired or replacement products back to the customer; these charges must be borne by the customer.
 - B. Damages caused by abuse, accident, shipping, misuse, overloading, modification, and the effects of corrosion, erosion and normal wear and tear.
 - C. Warranty is voided if the customer fails to install, maintain and operate the product in accordance with the instructions and recommendations set forth in the owner's manual(s), or if the product is used as rental equipment.
 - D. Pre-delivery service, i.e. assembly, oil or lubricants, and adjustment.
 - E. Items or service that are normally required to maintain the product, i.e. lubricants and filters.
 - F. Warrantor will not pay for repairs or adjustments to the product, or for any costs or labour, performed without Warrantor's prior authorization.

EXCLUSIONS AND LIMITATIONS : Warrantor makes no other warranty of any kind, express or implied. Implied warranties, including warranties of merchantability and of fitness for a particular purpose, are hereby disclaimed. This warranty service described above is the exclusive remedy under this warranty; liability for incidental and consequential damages is excluded to the extent permitted by law.
 7. **RESPONSIBILITIES OF PURCHASER UNDER THIS WARRANTY:**
 - A. The purchaser must provide dated proof of purchase and must notify Warrantor within the warranty period.
 - B. Deliver or ship the serviced generator or component to the nearest Warrantor's authorized service representative. Freight costs, if any, must be borne by the purchaser.
 8. **HAVE QUESTIONS?**
Email: warrantiesmallengines@gmail.com Phone: 866-960-2920
-

WARRANTY CARD

PERSONAL INFORMATION

Name: _____

Street Address: _____

City, State, ZIP: _____

Country: _____

Phone Number: _____

E-Mail: _____

INVERTER INFORMATION

Model Number: _____

Serial Number: _____

Date Purchased: _____

Purchased From: _____



TABLE OF CONTENTS

TECHNICAL SPECIFICATIONS	2	MAINTENANCE	17
LIMITED WARRANTY	3	Maintenance Schedule	17
Warranty Card	3	Engine Oil Maintenance	18
SAFETY	5	Checking Engine Oil	18
Safety Definitions	5	Adding Engine Oil	18
Safety Symbol Definitions	5	Changing Engine Oil	19
General Safety Rules	6	Air Filter Maintenance	19
Safety Labels and Decals	7	Cleaning the Air Filter	19
UNPACKING	7	Draining the Float Bowl	20
FEATURES	8	Spark Plug Maintenance	21
Basic Generator Features	8	Cleaning the Spark Arrestor	22
Control Panel Features	9	Cleaning the Generator	22
OPERATION	11	Storage	22
Before Starting the Generator	11	TROUBLESHOOTING	23
Location Selection	11	SCHEMATICS	24
Weather	11		
Dry Surface	11		
No Connected Loads	11		
Grounding the GENMAX Generator	11		
Powercord	12		
Generator Paralleling Operation	12		
Initial Oil Fill	13		
Adding/Checking Engine Fluids and Fuel	14		
Checking and/or Adding Engine Oil	14		
Adding Gasoline to the Fuel Tank	14		
Starting	15		
Stopping the Generator	16		
Using Efficiency Mode	16		
Resetting the Reset Breaker	16		

SAFETY

SAFETY DEFINITIONS

The words DANGER, WARNING, CAUTION and NOTICE are used throughout this manual to highlight important information. Be certain that the meanings of these alerts are known to all who work on or near the equipment.



This safety alert symbol appears with most safety statements. It means attention, become alert, your safety is involved! Please read and abide by the message that follows the safety alerts symbol.

DANGER

Indicates a hazardous situation which, if not avoided, *will* result in death or serious injury.

WARNING

Indicates a hazardous situation which, if not avoided, *could* result in death or serious injury.

CAUTION

Indicates a hazardous situation which, if not avoided, *could* result in minor or moderate injury.

NOTICE

Indicates a situation which can cause damage to the generator, personal property and/or the environment, or cause the equipment to operate improperly.

WARNING

Connection of the product to a building's electrical system is not applicable.

NOTE: Indicates a procedure, practice or condition that should be followed in order for the generator to function in the manner intended.

SAFETY SYMBOL DEFINITIONS

Symbol	Description
	Safety Alert Symbol
	Asphyxiation Hazard
	Burn Hazard
	Burst/Pressure Hazard
	Don't leave tools in the area
	Electrical Shock Hazard
	Explosion Hazard
	Fire Hazard
	Lifting Hazard
	Pinch-Point Hazard
	Read Manufacturer's Instructions
	Read Safety Messages Before Proceeding
	Wear Personal Protective Equipment (PPE)

SAFETY

GENERAL SAFETY RULES

DANGER



Never use the generator in a location that is wet or damp. Never expose the generator to rain, snow, water spray or standing water while in use. Protect the generator from all hazardous weather conditions. Moisture or ice can cause a short circuit or other malfunction in the electrical circuit.



Never operate the generator in an enclosed area. Engine exhaust contains carbon monoxide. Only operate the generator outside and away from windows, doors and vents.

WARNING



Voltage produced by the generator could result in death or serious injury.

- Never operate the generator in rain or a flood plain unless proper precautions are taken to avoid being subject to rain or a flood.
- Never use worn or damaged extension cords.
- Always have a licensed electrician connect the generator to the utility circuit.
- Never touch an operating generator if the inverter is wet or if you have wet hands.
- Never operate the generator in highly conductive areas such as around metal decking or steel works.
- Always use grounded extension cords. Always use three-wire or double-insulated power tools.
- Never touch live terminals or bare wires while the generator is operating.
- Be sure the generator is properly grounded before operating.

WARNING



Gasoline and gasoline vapors are extremely flammable and explosive under certain conditions.

- Always refuel the generator outdoors, in a well-ventilated area.
- Never remove the fuel cap with the engine running.
- Never refuel the generator while the engine is running. Always turn engine off and allow the generator to cool before refueling.
- Only fill fuel tank with gasoline.
- Keep sparks, open flames or other form of ignition (such as match, cigarette, static electric source) away when refueling.
- Never overfill the fuel tank. Leave room for fuel to expand. Overfilling the fuel tank can result in a sudden overflow of gasoline and result in spilled gasoline coming in contact with HOT surfaces. Spilled fuel can ignite. If fuel is spilled on the generator, wipe up any spills immediately. Dispose of rag properly. Allow area of spilled fuel to dry before operating the generator.
- Wear eye protection while refueling.
- Never use gasoline as a cleaning agent.
- Store any containers containing gasoline in a well-ventilated area, away from any combustibles or source of ignition.
- Check for fuel leaks after refueling. Never operate the engine if a fuel leak is discovered.

WARNING



Never operate the generator if powered items overheat, electrical output drops, there is sparking, flames or smoke coming from the generator, or if the receptacles are damaged.



Never use the generator to power medical support equipment.



Always remove any tools or other service equipment used during maintenance from the generator before operating.

NOTICE

Never modify the generator.

Never operate the generator if it vibrates at high levels, if engine speed changes greatly or if the engine misfires often.

Always disconnect tools or appliances from the generator before starting.

FEATURES

BASIC GENERATOR FEATURES

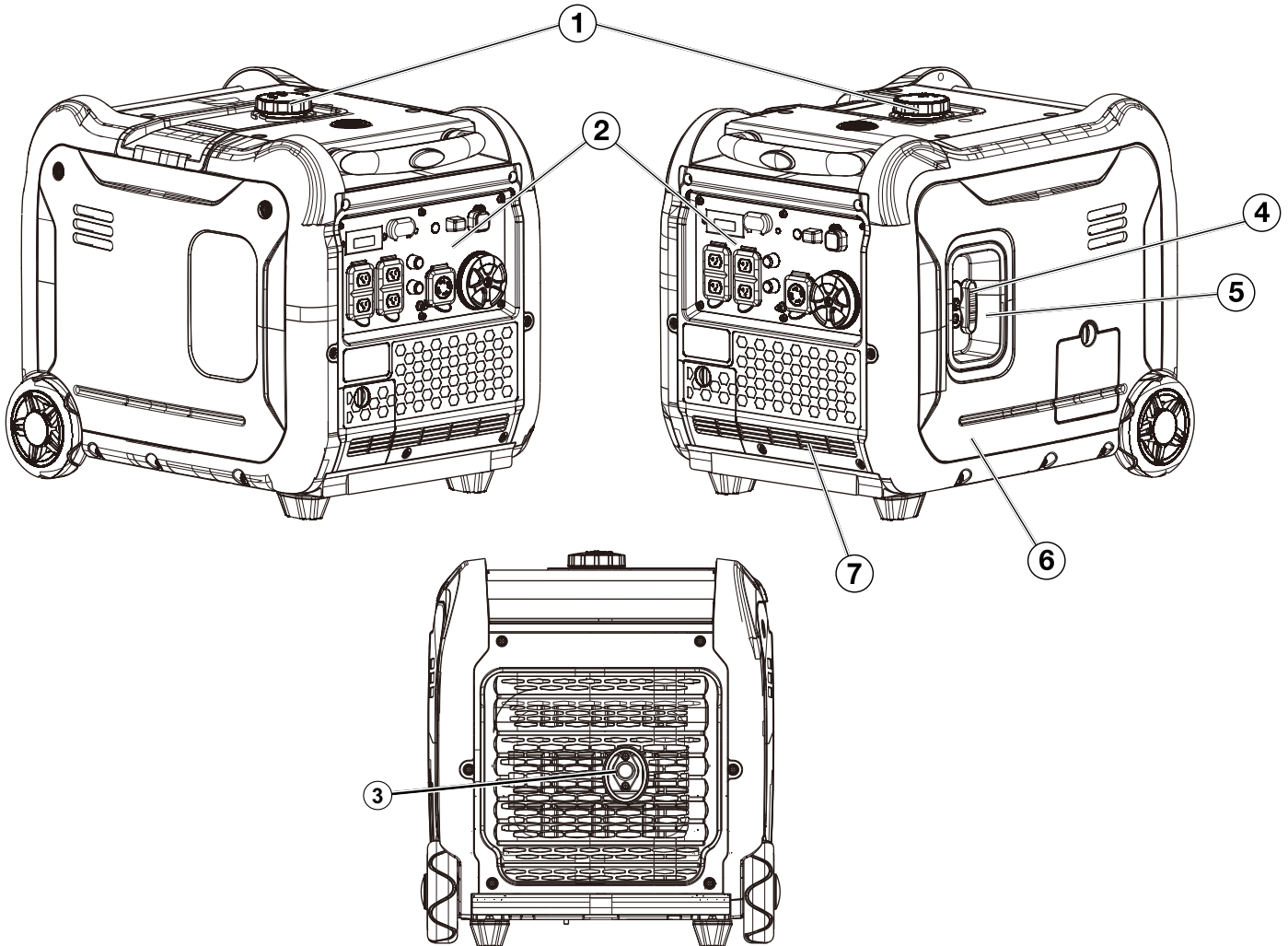

- ① **Fuel Cap:** Open the fuel tank cap and fill with proper amount of gasoline.
- ② **Control Panel:** Contains the reset breaker, outlets and warning lights.
- ③ **Muffler and Spark Arrestor:** Avoid contact until the engine is cooled down. The spark arrestor prevents sparks from exiting the muffler. It must be removed for servicing.
- ④ **Recoil Handle:** Pull to start the engine.
- ⑤ **Recoil Handle Protective Cover:** Prevents pull cord wire from damaging inverter body.
- ⑥ **Engine Service Panel:** Remove the panel to access the engine for maintenance.
- ⑦ **Engine Cooling Vents:** Helps move airflow in unit to regulate engine temperatures.

FEATURES

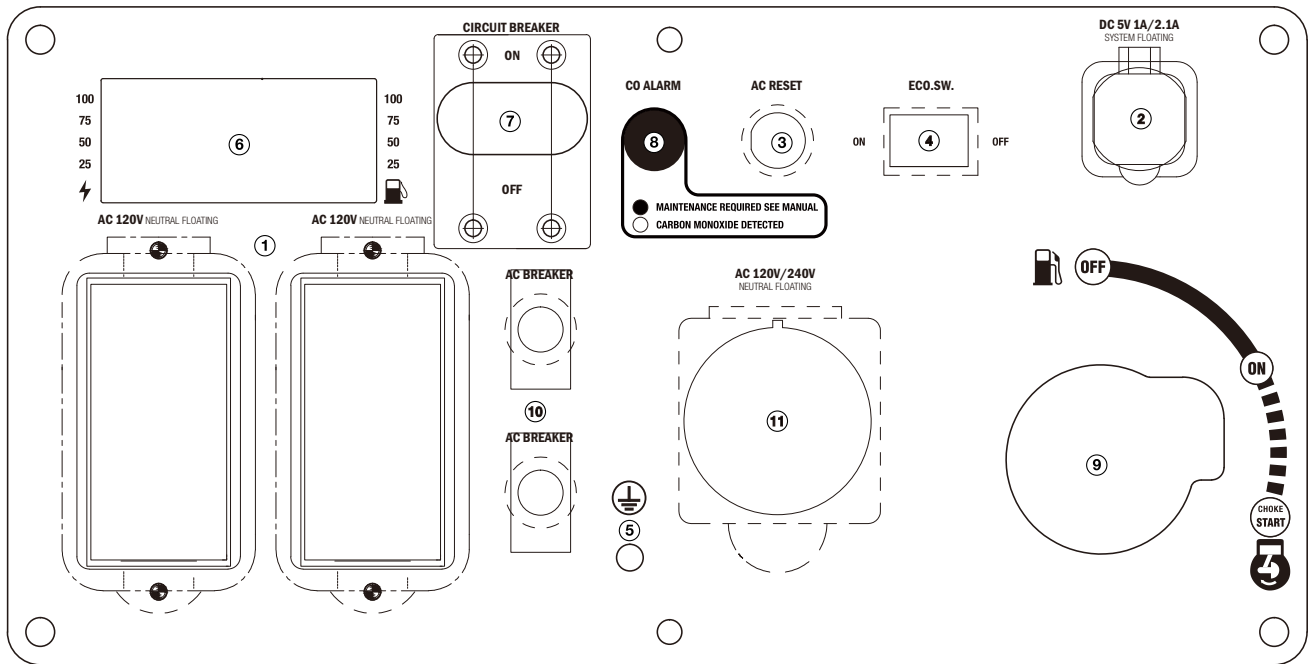

CONTROL PANEL FEATURES GM6000IE

- ① **120-Volt, 20-Amp Duplex Outlet (NEMA 5-20R):** The outlet is capable of carrying a maximum of 20 amps.
- ② **USB Duplex:** 5V DC that come in 1 amps and 2.1 amps.
- ③ **Reset Breaker:** If the generator is overloaded, the reset breaker will trip. The engine will continue to run, but there will be no output from the generator. Unplug the devices and reduce the load. Push in the reset breaker to reset it.
- ④ **Efficiency Mode Switch:** When turned to the ON position, the engine will sense the load needed and run at a slower RPM to save fuel.
- ⑤ **Ground Terminal:** The ground terminal is used to externally ground the generator.
- ⑥ **Multifunction Digital Display Meter:** Yellow light means that the amount of oil is too low, red light means that the machine overload, green light means normal operation; Power display on the left, oil level display on the right; Rolling display mode, respectively display accumulative running time, output voltage, frequency rolling display mode.
- ⑦ **Circuit Breaker:** A circuit breaker interrupts the current when the whole circuit is overloaded.
- ⑧ **CO Alarm LED:** Flashing red light: dangerous levels of carbon monoxide gas have built up leave immediately until area has aired out. Move generator to well-ventilated area before operation. Flashing yellow light: carbon monoxide sensor malfunction. Sensor needs service.
- ⑨ **Engine Switch:** Switch to ON to turn ON the fuel, then hold down to start the generator.
- ⑩ **AC Breaker:** If the generator is overloaded, the reset breaker will trip to block current.
- ⑪ **120-Volt, 30-Amp Outlet (NEMA RV30):** The outlet is capable of carrying a maximum of 30 amps.

FEATURES

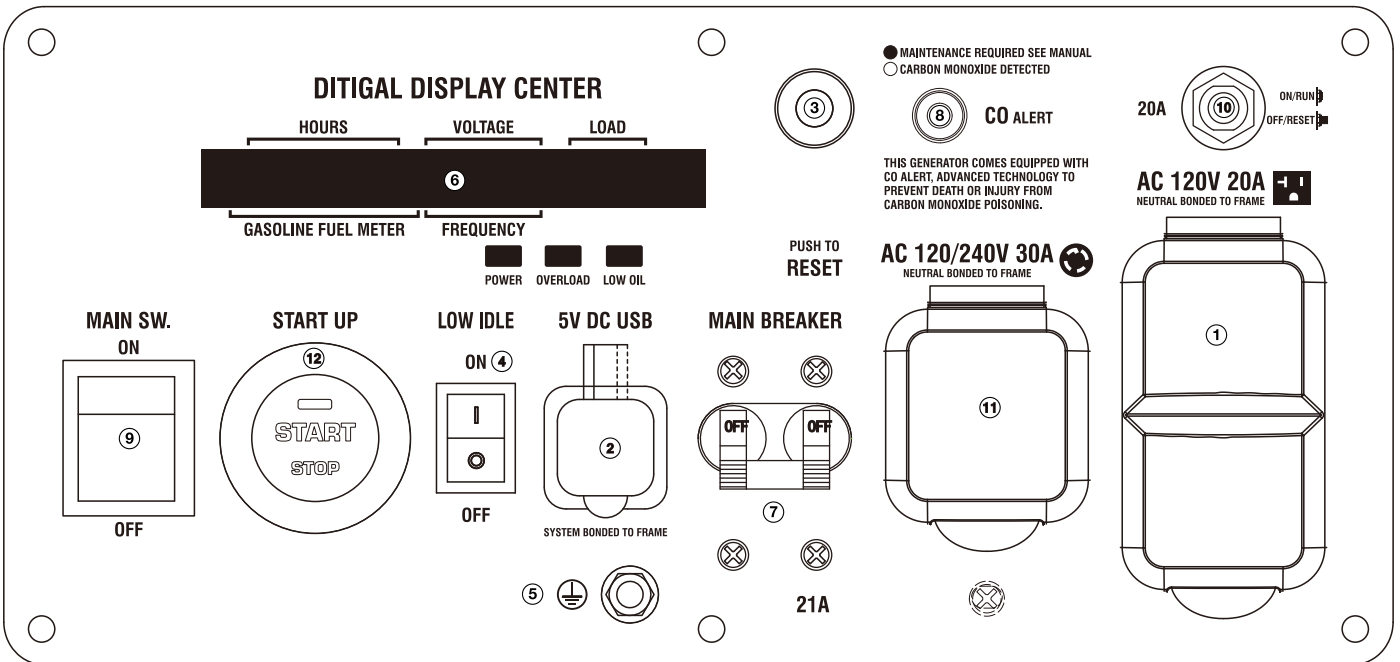

CONTROL PANEL FEATURES GM6000iED

- ① **120-Volt, 20-Amp Duplex Outlet (NEMA 5-20R):** The outlet is capable of carrying a maximum of 20 amps.
- ② **USB Duplex:** 5V DC that come in 1 amps and 2.1 amps.
- ③ **Reset Breaker:** If the generator is overloaded, the reset breaker will trip. The engine will continue to run, but there will be no output from the generator. Unplug the devices and reduce the load. Push in the reset breaker to reset it.
- ④ **Efficiency Mode Switch:** When turned to the ON position, the engine will sense the load needed and run at a slower RPM to save fuel.
- ⑤ **Ground Terminal:** The ground terminal is used to externally ground the generator.
- ⑥ **Multifunctional LED Digital Display Meter:** Red light (LOW OIL) means that the amount of oil is too low, red light (OVERLOAD) means that the machine overload, green light (POWER) means normal operation. LED Digital Display shows time, voltage, power, frequency and oil level; Time: scrolling display of single running time and accumulated running time; voltage: scrolling display of 120V and 240V.
- ⑦ **Main Brake:** A circuit breaker interrupts the current when the whole circuit is overloaded.
- ⑧ **CO Alarm LED:** Flashing red light: dangerous levels of carbon monoxide gas have built up leave immediately until area has aired out. Move generator to well-ventilated area before operation. Flashing yellow light: carbon monoxide sensor malfunction. Sensor needs service.
- ⑨ **Main SW.:** Manage battery power and shutdown.
- ⑩ **AC Protector:** If the generator is overload, the AC protector will trip to block current.
- ⑪ **120-Volt/240-Volt, 30-Amp Outlet (NEMA 14-30):** The outlet is capable of carrying a maximum of 30 amps.
- ⑫ **One Push Start:** Press this button, the engine can start and stop.

OPERATION

BEFORE STARTING THE GENERATOR



BEFORE STARTING THE GENERATOR, REVIEW SAFETY SECTION STARTING ON PAGE 5.

Location Selection – Before starting the generator, avoid exhaust and location hazards by verifying:

- You have selected a location to operate the generator that is outdoors and well ventilated.
- You have selected a location with a level and solid surface on which to place the generator.
- You have selected a location that is at least 6 feet (1.8 m) away from any building, other equipment or combustible material.
- If the generator is located close to a building, make sure it is not located near any windows, doors and/or vents.

⚠ DANGER	
<p>Using a generator indoors CAN KILL YOU IN MINUTES. Generator exhaust contains carbon monoxide. This is a poison you cannot see or smell.</p>	
<p>NEVER use inside a home or garage, EVEN IF doors and windows are open.</p>	<p>Only use OUTSIDE and far away from windows, doors, and vents.</p>
<p>Avoid other generator hazards. READ MANUAL BEFORE USE.</p>	

⚠ WARNING	
	<p>Always operate the generator on a level surface. Placing the generator on non level surfaces can cause the generator to tip over, causing fuel and oil to spill. Spilled fuel can ignite if it comes in contact with an ignition source such as a very hot surface.</p>

NOTICE	
<p>Only operate the inverter on a solid, level surface. Operating the generator on a surface with loose material such as sand or grass clippings can cause debris to be ingested by the inverter that could:</p> <ul style="list-style-type: none"> • Block cooling vents • Block air intake system 	

Weather – Never operate your generator outdoors during rain, snow or any combination of weather conditions that could lead to moisture collecting on, in or around the generator.

Dry Surface – Always operate the generator on a dry surface free of any moisture.

No Connected Loads – Make sure the generator has no connected loads before starting it. To ensure there are no connected loads, unplug any electrical extension cords that are plugged into the control panel receptacles.

NOTICE
<p>Starting the generator with loads already applied to it could result in damage to any appliance being powered off the generator during the brief start-up period.</p>

Grounding the GENMAX Generator
Consult with your local municipalities for your grounding codes.

⚠ WARNING	
	<p>Be sure the generator is properly connected to earth ground before operating.</p>

Carbon Monoxide Specification

CO DETECT technology monitors the accumulation of carbon monoxide (CO), a poisonous gas produced by engine exhaust when the generator is running. If CO Sensor detects unsafe elevated levels of CO gas, it automatically shuts off the engine. CO Sensor is not a substitute for an indoor carbon monoxide alarm or for safe operation. **DO NOT** allow engine exhaust fumes to enter a confined area through windows, doors, vents or other openings. Generators must **ALWAYS** be used outdoors, far away from occupied buildings with engine exhaust pointed away from people and buildings. Meets the requirements of ANSI/PGMA G300-2018.

OPERATION

POWERCORD

Using Extension Cords

GENMAX Portable Power assumes no responsibility for the content within this table. The use of this table is the responsibility of the user only. This table is intended for reference only. The results produced by using this table are not guaranteed to be correct or applicable in all situations as the type and construction of cords are highly variable. Always check with local regulations and a licensed electrician prior to installing or connecting an electrical appliance

Extension Cord Wire Gauge Size

AMPS	LENGTH OF EXTENSION CORD (ft)								
	10	20	30	40	50	60	80	100	120
5	20	18	16	14	12	12	10	10	8
10	18	16	14	12	12	10	10	8	8
15	16	14	12	12	10	10	8	8	6
20	14	12	12	10	10	8	8	6	6
25	12	12	10	10	8	8	6	6	6
30	12	10	10	8	8	6	6	6	6
35	10	10	8	8	6	6	6	6	6

INVERTER PARALLELING OPERATION

DANGER



Never connect the paralleling cord to the generator with the generator running. The generator must not be running and both the paralleling cord switches must be off when connecting the cords.

WARNING



Do not attempt to parallel the GENMAX generator with any other manufacturers' generator. Do not use the paralleling cord for any application other than generator paralleling. Do not use this cord on other manufacturers' generator.



Always ensure that both ends of the paralleling cord are switched off before connecting the generator.

GENERATOR PARALLELING OPERATION

1. Using only the GENMAX paralleling cord with both cord switches set to **OFF** (O), connect one male plug to one generator and connect the remaining plug into the other generator. Either of the receptacles on the generator can be used.
2. Start one of the generator and wait until the output ready light is on.
3. Turn both cord switches to ON (I).
4. Start the remaining generator; wait until the output ready light is on before connecting the load.
5. When power is present, a light will illuminate in the three-prong plug that is plugged into the generator.
6. To stop the generator, unplug all connected loads, turn both cord switches to **OFF** (O) and unplug the cord on each generator.
7. If during operation the generators' output is stopped due to overloading, reduce the connected load by unplugging appliances, and then push the reset button and restart the generator. When the ready light is on, the load can be reconnected.

OPERATION

INITIAL OIL FILL



BEFORE ADDING ENGINE OIL, REVIEW SAFETY SECTION STARTING ON PAGE 5.

NOTICE

Engine oil must be added when the generator is on a flat, level surface, or an inaccurate reading may result. Do not overfill. If the engine is overfilled with oil, it can cause serious engine damage.

1. Loosen the screw and remove the engine oil fill/drain plug service panel to access the oil fill/drain plug (see Figure 1)

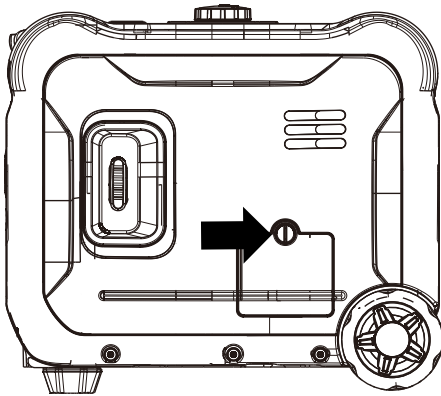

Figure 1: Engine Service Panel

2. Clean the area around the oil fill/drain plug and remove plug (See Figure 2).

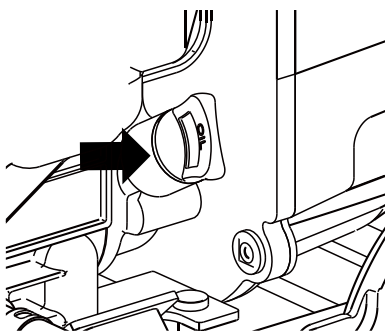

Figure 2: Oil Fill/Drain Plug

3. Using the supplied funnel and oil, pour the entire bottle of oil into the engine (see Figure 3).

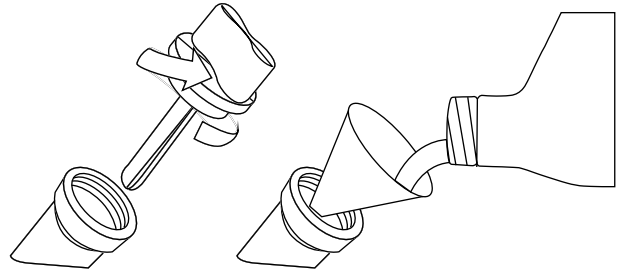

Figure 3: Oil Funnel

4. Do not overfill, if oil level is too high, oil will drain out through the fill plug. See correct oil level in Figure 4.

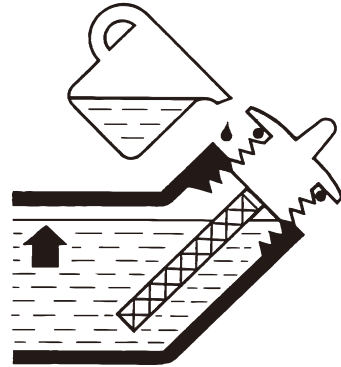

Figure 4: Engine Oil Correct Level

OPERATION

ADDING/CHECKING ENGINE FLUIDS AND FUEL



BEFORE ADDING/CHECKING ENGINE FLUIDS AND FUEL, REVIEW SAFETY SECTION STARTING ON PAGE 5.

DANGER



Filling the fuel tank with gasoline while the generator is running can cause gasoline to leak and come in contact with hot surfaces that can ignite the gasoline.

Before starting the generator, always check the level of:

- Engine oil
- Gasoline in the fuel tank

Once the generator is started and the engine gets warm, it is not safe to add gasoline to the fuel tank or engine oil to the engine while the engine is running or the engine and muffler are hot.

CHECKING AND / OR ADDING ENGINE OIL

WARNING



Internal pressure can build in the engine crankcase while the engine is running. Removing the oil fill plug/dipstick while the engine is hot can cause extremely hot oil to spray out of the crankcase and can severely burn skin. Allow engine oil to cool for several minutes before removing the oil fill plug/dipstick.

The unit as shipped does not contain oil in the engine. You must add engine oil before starting the generator for the first time. See *Initial Oil Fill* on page 13 for instructions on checking engine oil level and the procedure for adding engine oil.

NOTICE

The engine does not contain engine oil as shipped. Attempting to start the engine without adding engine oil will permanently damage internal engine components.

The engine is equipped with a low oil shutdown switch. If the oil level becomes low, the engine may shut down and not start until the oil is filled to the proper level.

The owner of the generator is responsible to ensure the proper oil level is maintained during the operation of the generator. Failure to maintain the proper oil level can result in engine damage.

ADDING GASOLINE TO THE FUEL TANK

WARNING



Never refuel the generator while the engine is running.



Always turn the engine off and allow the generator to cool before refueling.

CAUTION



Avoid prolonged skin contact with gasoline. Avoid prolonged breathing of gasoline vapors.

Required Gasoline – Only use gasoline that meets the following requirements:

- Unleaded gasoline only
- Gasoline with maximum 10% ethanol added
- Gasoline with an 87 octane rating or higher

Filling the Fuel Tank – Follow the steps below to fill the fuel tank:

1. Shut off the inverter.
2. Allow the inverter to cool down so all surface areas of the muffler and engine are cool to the touch.
3. Move the generator to a flat surface.
4. Clean area around the fuel cap.
5. Remove the fuel cap by rotating counterclockwise.

NOTICE

Do not overfill the fuel tank. Spilled fuel will damage some plastic parts.

6. Slowly add gasoline into the fuel tank. Be very careful not to overfill the tank. The gasoline level should NOT be higher than the red ring (see Figure 5).
7. Install the fuel cap by rotating clockwise.

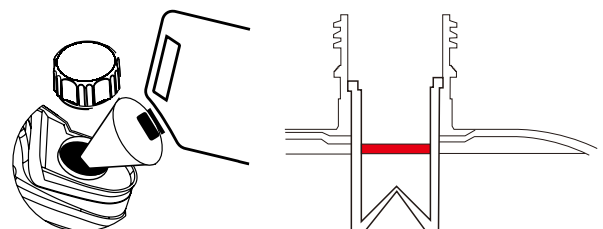

Figure 5: Maximum Gasoline Fill Level

OPERATION

STARTING THE GENERATOR



BEFORE STARTING THE GENERATOR, REVIEW SAFETY SECTION STARTING ON PAGE 5.

For proper starting and operation of the generator, make sure you review the generator features and their descriptions starting on page 8.

Before attempting to start the generator, verify the following:

- The engine is filled with engine oil (see Figure 4: *Engine Oil Correct Level* on page 13).
- The generator is situated in a proper location (see *Location Selection* on page 11).
- The generator is on a dry surface (see *Weather and Dry Surface* on page 11).
- All loads are disconnected from the generator (see *No Connected Loads* on page 11).
- The generator is properly grounded (see *Grounding the generator* on page 11)

DANGER	
	Never use the generator in a location that is wet or damp. Never expose the generator to rain, snow, water spray or standing water while in use. Protect the generator from all hazardous weather conditions. Moisture or ice can cause a short circuit or other malfunction in the electrical circuit.
	Never operate the generator in an enclosed area. Engine exhaust contains carbon monoxide. Only operate the generator outside and away from windows, doors and vents.

Hand Starter

1. Remove all the loads out of the output;
2. Turn the four-in-one switch to “CHOKE START”;
3. Then quickly pull the starting handle (see Figure 6);
4. After the generator starts, turn the four-in-one switch to “RUN” and the generator can be used normally with load.

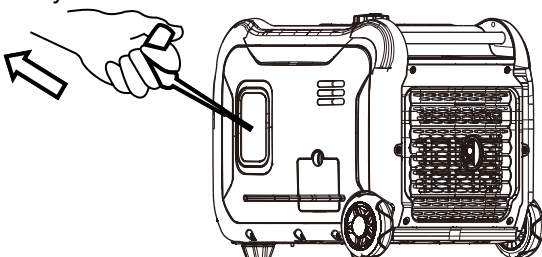

Figure 6: Pull the Recoil Handle out from Inverter

Electric starting

1. Remove all the loads out of the output;
2. Turn the four-in-one switch to “CHOKE START” and press the red button for 3-5 s before releasing the generator;
3. Then turn the four-in-one switch to “RUN” and the generator can be used normally with load.

WARNING: When the generator is started in warm state, there is no need to turn the four-in-one switch to “CHOKE START”.

NOTICE: Turning the four-in-one switch to “CHOKE START” and pressing the red button for more than 5 s will damage the starting motor. If startup fails, release the switch and wait 10 seconds before restarting.

If the speed of the starter motor drops rapidly after a period of time, it means that the battery should be recharged.

Dual Fuel

1. Press the main switch to "ON". The start button will light up for 2-3 seconds and then go off;
2. Switch the oil/gas switch to GAS. (or LPG);
3. Press the start button after the generator starts, the generator runs normally;
4. After the generator starts, turn the four-in-one switch to “RUN” and the generator can be used normally with load.

Tip: The generator needs to switch from fuel oil to gas state (or gas to fuel oil state) during normal operation. The generator must be directly turned to fuel oil or gas gear under no-load state to load and use normally.

Procedure For Connecting Gas Pipes

1. Connect the dedicated gas hose to the generator;
2. Switch the oil/gas switch to the GAS. switch;
3. Press the start button after the generator starts, the generator runs normally;
4. Open the air valve on the fuel tank and start the generator according to the normal start-up steps.