

GENMAX®

USER MANUAL



FOR MODELS:

GM2000i

Digital Inverter Generator

1600 Running Watts | 2000 Peak Watts

California

Proposition 65 Warning

The engine exhaust from this product contains chemicals known to the state of California to cause cancer, birth defects or other reproductive harm.

California

Proposition 65 Warning

Certain components in this product and its related accessories contain chemicals known to the state of California to cause cancer, birth defects or other reproductive harm. Wash hands after handling.

DISCLAIMERS:

All information, illustrations and specifications in this manual are based on the latest information available at the time of publishing. The illustrations used in this manual are intended as representative reference views only. Moreover, because of our continuous product improvement policy, we may modify information, illustrations and/or specifications to explain and/or exemplify a product, service or maintenance improvement. We reserve the right to make any change at any time without notice. Some images may vary depending upon which model is shown.

ALL RIGHTS RESERVED:

No part of this publication may be reproduced or used in any form by any means – graphic, electronic or mechanical, including photocopying, recording, taping or information storage and retrieval systems – without the written permission of CHONGQING DINKING POWER MACHINERY CO., LTD

DANGER



This manual contains important instructions for operating this inverter generator. For your safety and the safety of others, be sure to read this manual thoroughly before operating the generator. Failure to properly follow all instructions and precautions can cause you and others to be seriously hurt or killed.

TECHNICAL SPECIFICATIONS

Model Number	Running Watts	Peak Watts	Fuel Tank Size (Gel)	Rated Speed (RPM)	Ignition Type	Spark plug	Engine Disp (cc)	Stroke X Bore	Oil Capacity (Gel)	Oil Type
GM2000i	1600	2000	1.1	4500	CDI	A5RTC	79.7	48.6×43	0.09	10W30

NEUTRAL FLOATING

For portable generators where the neutral is floating, the operator's manual shall include the following wording or equivalent:

The portable generator stator winding is isolated from the frame and from the AC receptacle ground pin; and Electrical devices that require a connection between one conductor pin and the grounded receptacle pin may not function properly.

LIMITED WARRANTY

1. **DURATION** : One (1) year from the date of purchase by the original purchaser (retail customer) on products used solely for consumer applications; if a product is used for business, commercial, or industrial applications, the warranty period will be limited to ninety (90) days from the date of purchase.
 2. **WHO GIVES THIS WARRANTY (WARRANTOR):**
CHONGQING DINKING POWER MACHINERY CO., LTD
 3. **WHO RECEIVES THIS WARRANTY(PURCHASER):**
The original purchaser (other than for purposes of resale) of the Genmax' s inverter.
 4. **WHAT PRODUCTS ARE COVERED BY THIS WARRANTY:**
Any portable generator supplied or manufactured by Warrantor.
 5. **WHAT IS COVERED UNDER THIS WARRANTY:**
Substantial defects on material and workmanship which occur within the duration of the warranty period.
 6. **WHAT IS NOT COVERED UNDER THIS WARRANTY:**
 - A. Transportation charges for sending the product to Warrantor or its authorized service representative for warranty service, or for shipping repaired or replacement products back to the customer; these charges must be borne by the customer.
 - B. Damages caused by abuse, accident, shipping, misuse, overloading, modification, and the effects of corrosion, erosion and normal wear and tear.
 - C. Warranty is voided if the customer fails to install, maintain and operate the product in accordance with the instructions and recommendations set forth in the owner's manual(s), or if the product is used as rental equipment.
 - D. Pre-delivery service, i.e. assembly, oil or lubricants, and adjustment.
 - E. Items or service that are normally required to maintain the product, i.e. lubricants and filters.
 - F. Warrantor will not pay for repairs or adjustments to the product, or for any costs or labour, performed without Warrantor's prior authorization.

EXCLUSIONS AND LIMITATIONS : Warrantor makes no other warranty of any kind, express or implied. Implied warranties, including warranties of merchantability and of fitness for a particular purpose, are hereby disclaimed. This warranty service described above is the exclusive remedy under this warranty; liability for incidental and consequential damages is excluded to the extent permitted by law.
 7. **RESPONSIBILITIES OF PURCHASER UNDER THIS WARRANTY:**
 - A. The purchaser must provide dated proof of purchase and must notify Warrantor within the warranty period.
 - B. Deliver or ship the serviced generator or component to the nearest Warrantor's authorized service representative. Freight costs, if any, must be borne by the purchaser.
 8. **HAVE QUESTIONS?**
Email: warrantiesmallengines@gmail.com Phone: 866-960-2920
-

WARRANTY CARD

PERSONAL INFORMATION

Name: _____

Street Address: _____

City, State, ZIP: _____

Country: _____

Phone Number: _____

E-Mail: _____

INVERTER INFORMATION

Model Number: _____

Serial Number: _____

Date Purchased: _____

Purchased From: _____



TABLE OF CONTENTS

TECHNICAL SPECIFICATIONS	2	MAINTENANCE	16
LIMITED WARRANTY	3	Maintenance Schedule	16
Warranty Card	3	Engine Oil Maintenance	17
SAFETY	5	Checking Engine Oil	17
Safety Definitions	5	Adding Engine Oil	17
Safety Symbol Definitions	5	Changing Engine Oil	18
General Safety Rules	6	Air Filter Maintenance	18
Safety Labels and Decals	7	Cleaning the Air Filter	18
UNPACKING	7	Draining the Float Bowl	19
FEATURES	8	Spark Plug Maintenance	20
Basic Inverter Features GM2000i	8	Cleaning the Spark Arrestor	21
Control Panel Features GM2000i	9	Cleaning the Inverter	21
OPERATION	10	Storage	21
Before Starting the Inverter	10	TROUBLESHOOTING	22
Location Selection	10		
Weather	10		
Dry Surface	10		
No Connected Loads	10		
Grounding the GENMAX Inverters	10		
Powercord	11		
Inverter Paralleling Operation	11		
Initial Oil Fill	12		
Adding/Checking Engine Fluids and Fuel	13		
Checking and/or Adding Engine Oil	13		
Adding Gasoline to the Fuel Tank	13		
Starting GM2000i	14		
Stopping the Inverter	15		
Using Efficiency Mode	15		
Resetting the Reset Breaker	15		

SAFETY

SAFETY DEFINITIONS

The words DANGER, WARNING, CAUTION and NOTICE are used throughout this manual to highlight important information. Be certain that the meanings of these alerts are known to all who work on or near the equipment.



This safety alert symbol appears with most safety statements. It means attention, become alert, your safety is involved! Please read and abide by the message that follows the safety alerts symbol.

DANGER

Indicates a hazardous situation which, if not avoided, *will* result in death or serious injury.

WARNING

Indicates a hazardous situation which, if not avoided, *could* result in death or serious injury.

CAUTION

Indicates a hazardous situation which, if not avoided, *could* result in minor or moderate injury.

NOTICE

Indicates a situation which can cause damage to the generator, personal property and/or the environment, or cause the equipment to operate improperly.

WARNING

Connection of the product to a building's electrical system is not applicable.

NOTE: Indicates a procedure, practice or condition that should be followed in order for the generator to function in the manner intended.

SAFETY SYMBOL DEFINITIONS

Symbol	Description
	Safety Alert Symbol
	Asphyxiation Hazard
	Burn Hazard
	Burst/Pressure Hazard
	Don't leave tools in the area
	Electrical Shock Hazard
	Explosion Hazard
	Fire Hazard
	Lifting Hazard
	Pinch-Point Hazard
	Read Manufacturer's Instructions
	Read Safety Messages Before Proceeding
	Wear Personal Protective Equipment (PPE)

SAFETY

GENERAL SAFETY RULES

⚠ DANGER



Never use the inverter in a location that is wet or damp. Never expose the inverter to rain, snow, water spray or standing water while in use. Protect the inverter from all hazardous weather conditions. Moisture or ice can cause a short circuit or other malfunction in the electrical circuit.



Never operate the inverter in an enclosed area. Engine exhaust contains carbon monoxide. Only operate the inverter outside and away from windows, doors and vents.

⚠ WARNING



Voltage produced by the inverter could result in death or serious injury.

- Never operate the inverter in rain or a flood plain unless proper precautions are taken to avoid being subject to rain or a flood.
- Never use worn or damaged extension cords.
- Always have a licensed electrician connect the inverter to the utility circuit.
- Never touch an operating inverter if the inverter is wet or if you have wet hands.
- Never operate the inverter in highly conductive areas such as around metal decking or steel works.
- Always use grounded extension cords. Always use three-wire or double-insulated power tools.
- Never touch live terminals or bare wires while the inverter is operating.
- Be sure the inverter is properly grounded before operating.

⚠ WARNING



Gasoline and gasoline vapors are extremely flammable and explosive under certain conditions.

- Always refuel the generator outdoors, in a well-ventilated area.
- Never remove the fuel cap with the engine running.
- Never refuel the inverter while the engine is running. Always turn engine off and allow the generator to cool before refueling.
- Only fill fuel tank with gasoline.
- Keep sparks, open flames or other form of ignition (such as match, cigarette, static electric source) away when refueling.
- Never overfill the fuel tank. Leave room for fuel to expand. Overfilling the fuel tank can result in a sudden overflow of gasoline and result in spilled gasoline coming in contact with HOT surfaces. Spilled fuel can ignite. If fuel is spilled on the inverter, wipe up any spills immediately. Dispose of rag properly. Allow area of spilled fuel to dry before operating the inverter.
- Wear eye protection while refueling.
- Never use gasoline as a cleaning agent.
- Store any containers containing gasoline in a well-ventilated area, away from any combustibles or source of ignition.
- Check for fuel leaks after refueling. Never operate the engine if a fuel leak is discovered.

⚠ WARNING



Never operate the inverter if powered items overheat, electrical output drops, there is sparking, flames or smoke coming from the inverter, or if the receptacles are damaged.



Never use the inverter to power medical support equipment.



Always remove any tools or other service equipment used during maintenance from the inverter before operating.

NOTICE

Never modify the inverter.

Never operate the inverter if it vibrates at high levels, if engine speed changes greatly or if the engine misfires often.

Always disconnect tools or appliances from the inverter before starting.

SAFETY

SAFETY LABELS AND DECALS GM2000i

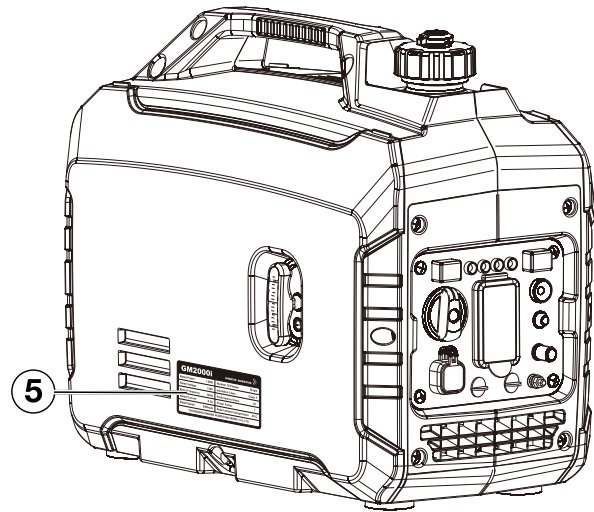
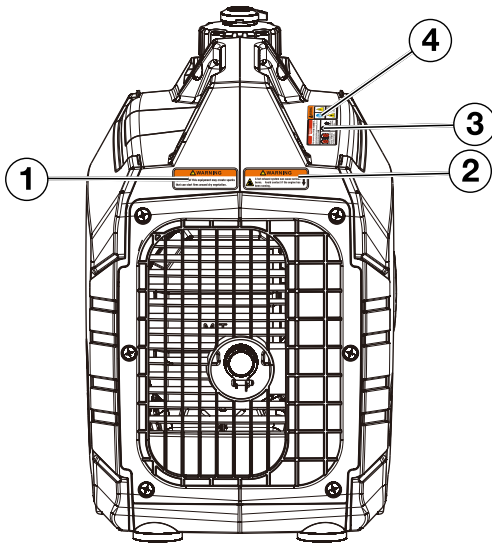

1 **WARNING**
Operation of this equipment may create sparks that can start fires around dry vegetation.

Do not use the generator in a direction that the exhaust emission to the occupied structures, the sparks in the exhaust emission may start fires.

2 **WARNING**
A hot exhaust system can cause serious burns. Avoid contact if the engine has been running.

A hot exhaust system can cause serious burns, avoid contact if the engine has been running.

5 **GM2000i** INVERTER GENERATOR

Rated Power	1.6KW	Number Of Phases	Single
Rated Voltage	120V	Insulation Class	Class F
Rated Frequency	60Hz	Performance Class	G1
Rated Current	8.3A	Power Factor	1
Rated Speed	5000rpm	Rated ambient temperature	25°C

CHONGQING DINKING POWER MACHINERY CO.,LTD.

3 **DANGER**
Using a generator indoors CAN KILL YOU IN MINUTES. Generator exhaust contains carbon monoxide. This is a poison you cannot see or smell.

NEVER use inside a home or garage. EVEN IF doors and windows are open. Only use OUTSIDE and far away from windows, doors, and vents.

Do not use the generator in door or garage, the exhaust contains carbon monoxide, this is a poison you cannot see or smell, and it will kill you in minutes.

4 **WARNING**

PETROL
Highly Flammable

Before using the generator, please read the operation manual. Be careful with the shock hazard. Be careful, the fuel is flammable, do not add the fuel when the engine is running.

UNPACKING

CAUTION

Always have assistance when lifting the inverter. The inverter is heavy; lifting it could cause bodily harm.

Avoid cutting on or near staples to prevent personal injury.

Tools required – box cutter or similar device.

- Carefully cut the packing tape on top of the carton.
- Remove socket wrench, oil and funnel and save for later.
- Carefully cut two sides of the carton to remove the inverter.

WHAT COMES IN THE BOX

- Spark Plug Socket Wrench (1)
- Owner Manual (1)
- Warranty Information (1)
- Funnel (1)

FEATURES

BASIC INVERTER FEATURES GM2000i

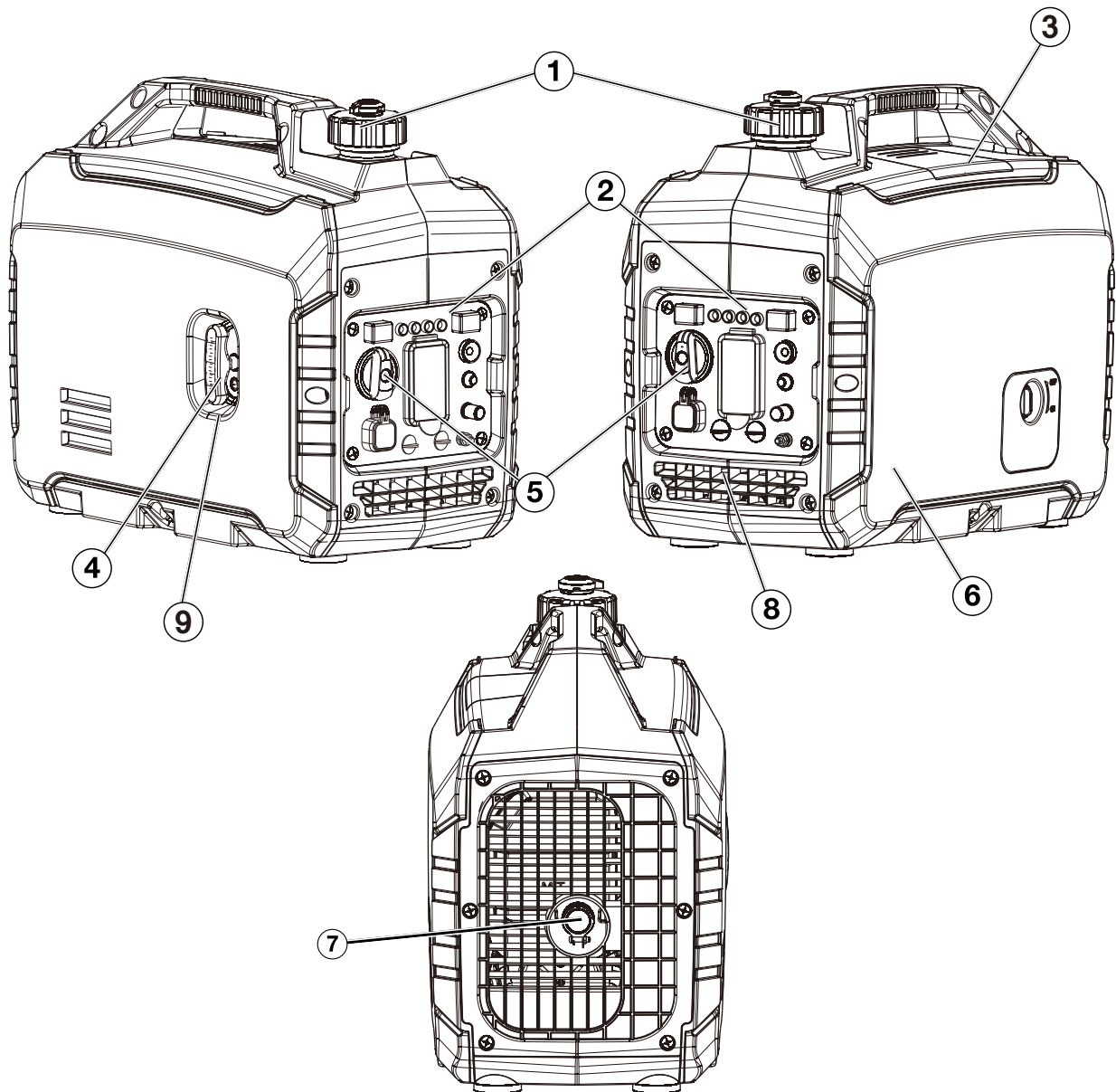

① **Fuel Cap and Vent:** Open the vent to run the engine and close the vent when the engine is off.

② **Control Panel:** Contains the reset breaker, outlets and warning lights.

③ **Spark Plug Access Cover:** Remove the cover to service the spark plug.

④ **Recoil Handle:** Pull to start the engine.

⑤ **Fuel Switch:** Fuel switch is OFF, and the engine will not run.

⑥ **Engine Service Panel:** Remove the panel to access the engine for maintenance.

⑦ **Muffler and Spark Arrestor:** Avoid contact until the engine is cooled down. The spark arrestor prevents sparks from exiting the muffler. It must be removed for servicing.

⑧ **Engine Cooling Vents:** Helps move airflow in unit to regulate engine temperatures.

⑨ **Recoil Handle Protective Cover:** Prevents pull cord wire from damaging inverter body.

FEATURES

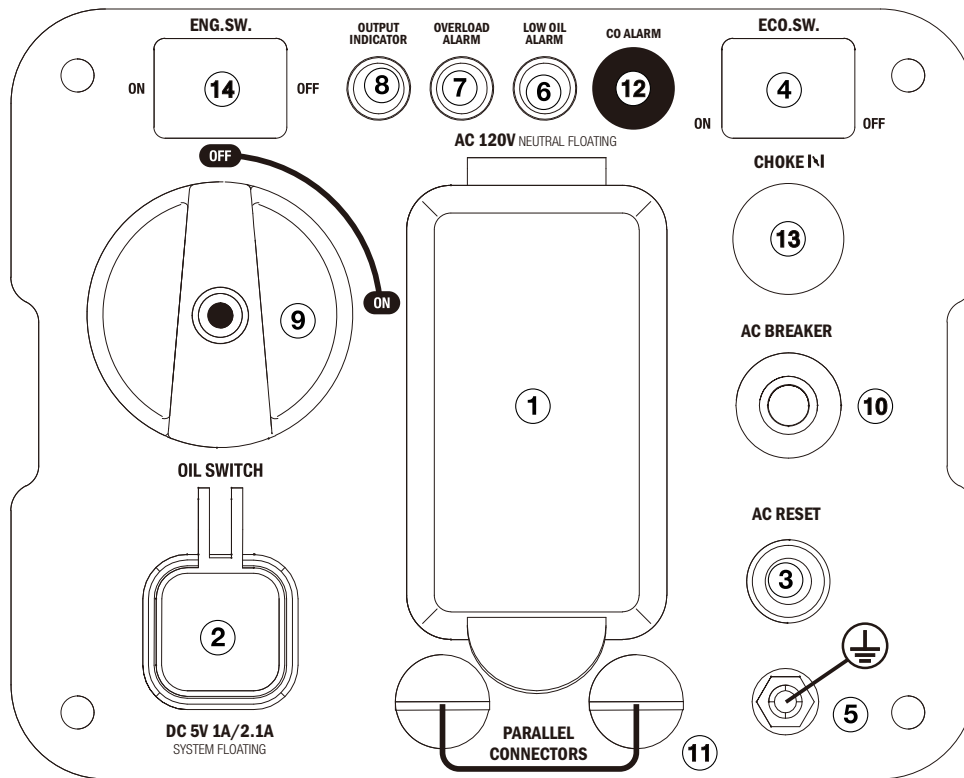

CONTROL PANEL FEATURES GM2000i

- ① **120-Volt, 20-Amp Duplex Outlet (NEMA 5-20R):** The outlet is capable of carrying a maximum of 20 amps.
- ② **USB Duplex:** 5V DC that come in 1 amps and 2.1 amps.
- ③ **Reset Breaker:** If the inverter is overloaded, the reset breaker will trip. The engine will continue to run, but there will be no output from the inverter. Unplug the devices and reduce the load. Push in the reset breaker to reset it.
- ④ **Efficiency Mode Switch:** When turned to the ON position, the engine will sense the load needed and run at a slower RPM to save fuel.
- ⑤ **Ground Terminal:** The ground terminal is used to externally ground the inverter.
- ⑥ **Low Oil Alarm:** Indicates low oil level.
- ⑦ **Overload Alarm:** Indicates that the inverter is overloaded.
- ⑧ **Output Indicator:** Indicates the inverter is ready to be used.
- ⑨ **Fuel Switch:** Fuel switch is OFF, and the engine will not run.
- ⑩ **AC Breaker:** If the inverter is overloaded, the reset breaker will trip to block current.
- ⑪ **Parallel Connectors:** To increase AC power output, the connector sockets are used to connect the two same type generator with special paralleling cords. The connector sockets is only used to the communication between the inverters, they can not used for AC power output. The special paralleling cords shall be purchase separately, and they shall be approved by certification body.
- ⑫ **CO Alarm:** Flashing red light: dangerous levels of carbon monoxide gas have built up leave immediately until area has aired out. Move generator to well-ventilated area before operation. Flashing yellow light: carbon monoxide sensor malfunction. Sensor needs service.
- ⑬ **Choke Switch:** when cold start, properly close part of the air inlet to improve the engine start performance, after normal operation, the choke should be fully open, otherwise the engine can not run properly because of too thick mixture and cause too much oil consumption.
- ⑭ **Engine Switch:** Press ON to start the engine, press OFF to turn OFF the engine

OPERATION

BEFORE STARTING THE INVERTER



BEFORE STARTING THE INVERTER, REVIEW SAFETY SECTION STARTING ON PAGE 5.

Location Selection – Before starting the inverter, avoid exhaust and location hazards by verifying:

- You have selected a location to operate the inverter that is outdoors and well ventilated.
- You have selected a location with a level and solid surface on which to place the inverter.
- You have selected a location that is at least 6 feet (1.8 m) away from any building, other equipment or combustible material.
- If the inverter is located close to a building, make sure it is not located near any windows, doors and/or vents.

⚠ DANGER

Using a generator indoors
CAN KILL YOU IN MINUTES.

Generator exhaust contains carbon monoxide.
This is a poison you cannot see or smell.



NEVER use inside a home or garage, **EVEN IF** doors and windows are open.



Only use **OUTSIDE** and far away from windows, doors, and vents.

Avoid other generator hazards.
READ MANUAL BEFORE USE.

⚠ WARNING



Always operate the inverter on a level surface. Placing the inverter on non level surfaces can cause the inverter to tip over, causing fuel and oil to spill. Spilled fuel can ignite if it comes in contact with an ignition source such as a very hot surface.

NOTICE

Only operate the inverter on a solid, level surface. Operating the inverter on a surface with loose material such as sand or grass clippings can cause debris to be ingested by the inverter that could:

- Block cooling vents
- Block air intake system

Weather – Never operate your inverter outdoors during rain, snow or any combination of weather conditions that could lead to moisture collecting on, in or around the generator.

Dry Surface – Always operate the inverter on a dry surface free of any moisture.

No Connected Loads – Make sure the inverter has no connected loads before starting it. To ensure there are no connected loads, unplug any electrical extension cords that are plugged into the control panel receptacles.

NOTICE

Starting the inverter with loads already applied to it could result in damage to any appliance being powered off the inverter during the brief start-up period.

Grounding the GENMAX Inverters

Consult with your local municipalities for your grounding codes.

⚠ WARNING



Be sure the inverter is properly connected to earth ground before operating.

OPERATION

POWERCORD

Using Extension Cords

GENMAX Portable Power assumes no responsibility for the content within this table. The use of this table is the responsibility of the user only. This table is intended for reference only. The results produced by using this table are not guaranteed to be correct or applicable in all situations as the type and construction of cords are highly variable. Always check with local regulations and a licensed electrician prior to installing or connecting an electrical appliance

Extension Cord Wire Gauge Size

AMPS	LENGTH OF EXTENSION CORD (ft)								
	10	20	30	40	50	60	80	100	120
5	20	18	16	14	12	12	10	10	8
10	18	16	14	12	12	10	10	8	8
15	16	14	12	12	10	10	8	8	6
20	14	12	12	10	10	8	8	6	6
25	12	12	10	10	8	8	6	6	6
30	12	10	10	8	8	6	6	6	6
35	10	10	8	8	6	6	6	6	6

INVERTER PARALLELING OPERATION

DANGER

Never connect the paralleling cord to the inverters with the inverters running. The inverters must not be running and both the paralleling cord switches must be off when connecting the cords.

WARNING

Do not attempt to parallel the GENMAX inverter with any other manufacturers' inverters. Do not use the paralleling cord for any application other than inverter paralleling. Do not use this cord on other manufacturers' inverters.

Always ensure that both ends of the paralleling cord are switched off before connecting the inverters.

INVERTER PARALLELING OPERATION

1. Using only the GENMAX paralleling cord with both cord switches set to **OFF** (O), connect one male plug to one inverter and connect the remaining plug into the other inverter. Either of the receptacles on the inverters can be used.
2. Start one of the inverters and wait until the output ready light is on.
3. Turn both cord switches to ON (I).
4. Start the remaining inverter; wait until the output ready light is on before connecting the load.
5. When power is present, a light will illuminate in the three-prong plug that is plugged into the inverter.
6. To stop the inverters, unplug all connected loads, turn both cord switches to **OFF** (O) and unplug the cord on each inverter.
7. If during operation the inverters' output is stopped due to overloading, reduce the connected load by unplugging appliances, and then push the reset button and restart the inverter. When the ready light is on, the load can be reconnected.

OPERATION

INITIAL OIL FILL



BEFORE ADDING ENGINE OIL, REVIEW SAFETY SECTION STARTING ON PAGE 5.

NOTICE

Engine oil must be added when the inverter is on a flat, level surface, or an inaccurate reading may result. Do not overfill. If the engine is overfilled with oil, it can cause serious engine damage.

1. Loosen the screw and remove the engine oil fill/drain plug service panel to access the oil fill/drain plug (see Figure 1)

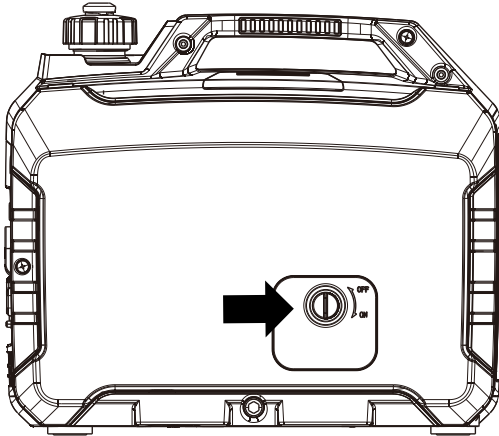

Figure 1: Engine Service Panel

2. Clean the area around the oil fill/drain plug and remove plug (See Figure 2).

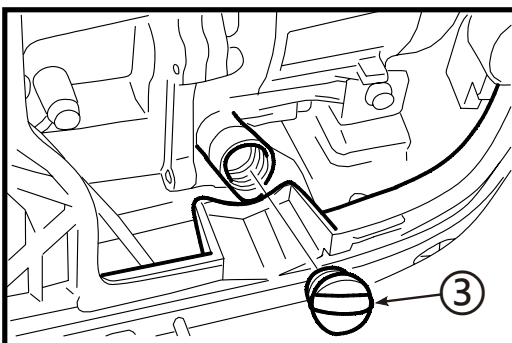

Figure 2: Oil Fill/Drain Plug

3. Using the supplied funnel and oil, pour the entire bottle of oil into the engine (see Figure 3).

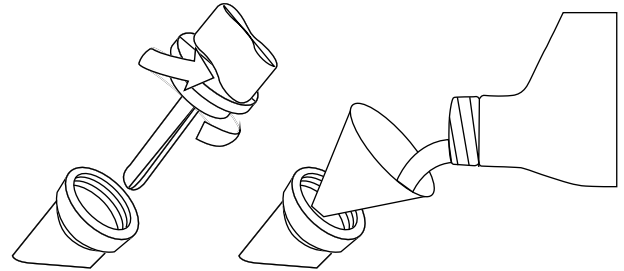

Figure 3: Oil Funnel

4. Do not overfill, if oil level is too high, oil will drain out through the fill plug. See correct oil level in Figure 4.

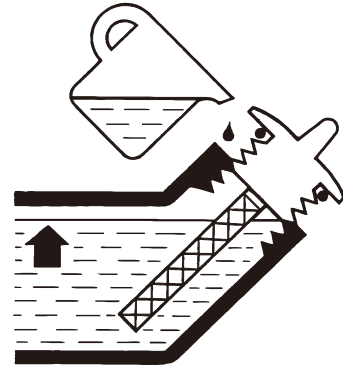

Figure 4: Engine Oil Correct Level

OPERATION

ADDING/CHECKING ENGINE FLUIDS AND FUEL



BEFORE ADDING/CHECKING ENGINE FLUIDS AND FUEL, REVIEW SAFETY SECTION STARTING ON PAGE 5.

DANGER



Filling the fuel tank with gasoline while the inverter is running can cause gasoline to leak and come in contact with hot surfaces that can ignite the gasoline.

Before starting the inverter, always check the level of:

- Engine oil
- Gasoline in the fuel tank

Once the inverter is started and the engine gets warm, it is not safe to add gasoline to the fuel tank or engine oil to the engine while the engine is running or the engine and muffler are hot.

CHECKING AND / OR ADDING ENGINE OIL

WARNING



Internal pressure can build in the engine crankcase while the engine is running. Removing the oil fill plug/dipstick while the engine is hot can cause extremely hot oil to spray out of the crankcase and can severely burn skin. Allow engine oil to cool for several minutes before removing the oil fill plug/dipstick.

The unit as shipped does not contain oil in the engine. You must add engine oil before starting the inverter for the first time. See *Initial Oil Fill* on page 13 for instructions on checking engine oil level and the procedure for adding engine oil.

NOTICE

The engine does not contain engine oil as shipped. Attempting to start the engine without adding engine oil will permanently damage internal engine components.

The engine is equipped with a low oil shutdown switch. If the oil level becomes low, the engine may shut down and not start until the oil is filled to the proper level.

The owner of the inverter is responsible to ensure the proper oil level is maintained during the operation of the generator. Failure to maintain the proper oil level can result in engine damage.

ADDING GASOLINE TO THE FUEL TANK

WARNING



Never refuel the inverter while the engine is running.



Always turn the engine off and allow the inverter to cool before refueling.

CAUTION



Avoid prolonged skin contact with gasoline. Avoid prolonged breathing of gasoline vapors.

Required Gasoline – Only use gasoline that meets the following requirements:

- Unleaded gasoline only
- Gasoline with maximum 10% ethanol added
- Gasoline with an 87 octane rating or higher

Filling the Fuel Tank – Follow the steps below to fill the fuel tank:

1. Shut off the inverter.
2. Allow the inverter to cool down so all surface areas of the muffler and engine are cool to the touch.
3. Move the inverter to a flat surface.
4. Clean area around the fuel cap.
5. Remove the fuel cap by rotating counterclockwise.

NOTICE

Do not overfill the fuel tank. Spilled fuel will damage some plastic parts.

6. Slowly add gasoline into the fuel tank. Be very careful not to overfill the tank. The gasoline level should NOT be higher than the red ring (see Figure 5).
7. Install the fuel cap by rotating clockwise.

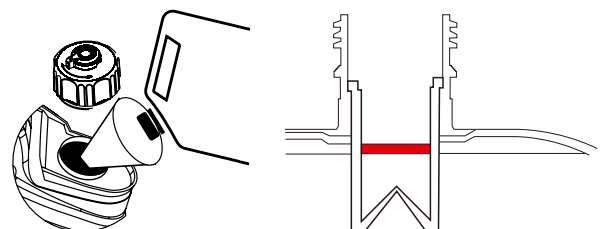

Figure 5: Maximum Gasoline Fill Level

OPERATION

STARTING THE INVERTER



BEFORE STARTING THE INVERTER, REVIEW SAFETY SECTION STARTING ON PAGE 5.

For proper starting and operation of the inverter, make sure you review the inverter features and their descriptions starting on page 8.

Before attempting to start the inverter, verify the following:

- The engine is filled with engine oil (see Figure 4: *Engine Oil Correct Level* on page 13).
- The inverter is situated in a proper location (see *Location Selection* on page 11).
- The inverter is on a dry surface (see *Weather and Dry Surface* on page 11).
- All loads are disconnected from the inverter (see *No Connected Loads* on page 11).
- The inverter is properly grounded (see *Grounding the Inverter* on page 11)

DANGER



Never use the inverter in a location that is wet or damp. Never expose the inverter to rain, snow, water spray or standing water while in use. Protect the inverter from all hazardous weather conditions. Moisture or ice can cause a short circuit or other malfunction in the electrical circuit.



Never operate the inverter in an enclosed area. Engine exhaust contains carbon monoxide. Only operate the inverter outside and away from windows, doors and vents.

Starting

1. Check oil levels. If it is the first time starting make sure to add oil (see *Initial Oil Fill* on page 13).
2. Remove the load from all output ends.
3. Turn off switch to “ON” .
4. Turn ventilation knob of fuel tank cap to “ON” (see Figure 6).

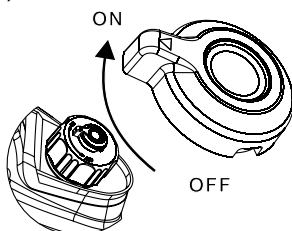

Figure 6: fuel tank vent

5. Flip the oil switch to “ON” choke and pull out (see Figure 7).

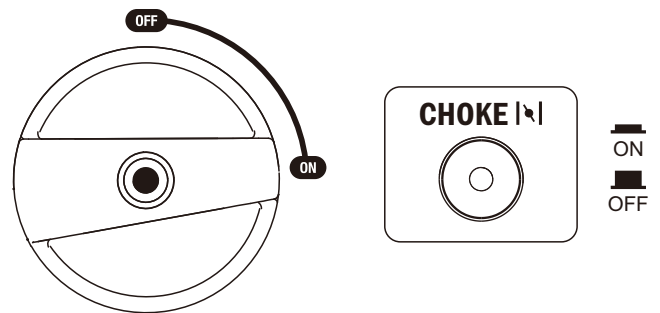

Figure 7: Turn Engine/Fuel Switch to CHOKE Position

6. Firmly grasp and pull the recoil handle slowly until you feel increased resistance. At this point, apply a rapid pull while pulling out from the inverter (see Figure 8).

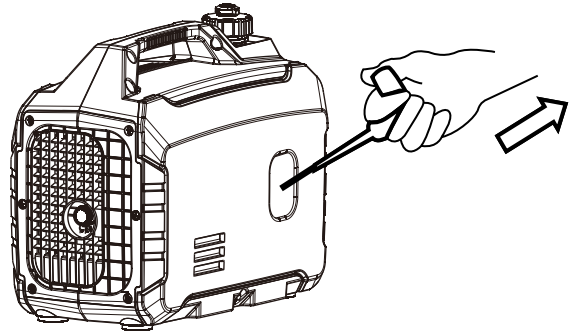

Figure 8: Pull the Recoil Handle out from Inverter

OPERATION

STOPPING THE INVERTER

Normal Operation

During normal operation, use the following steps to stop your inverter:

1. Remove any connected loads from the control panel receptacles.
2. Allow the inverter to run at “no load” to reduce and stabilize engine and alternator temperatures.
3. Turn **OFF** the oil switch, Turn **OFF** the switch (see Figure 9).

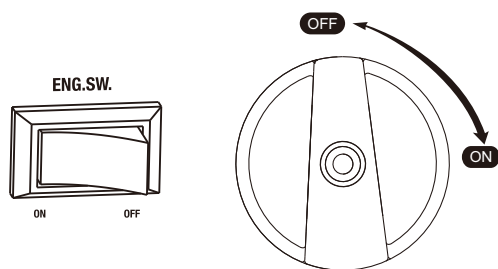

Figure 9: Turn Engine/Fuel Switch to OFF Position

4. After the generator has completely cooled down, turn ventilation knob on fuel tank cap to **OFF**.

During an Emergency

If there is an emergency and the inverter must be stopped quickly, move the engine control switch to the **OFF** position immediately (see Figure 9).

USING EFFICIENCY MODE

The inverter is equipped with an efficiency mode switch to minimize fuel consumption. In efficiency mode, the inverter will sense the load and adjust the engine RPM to the current load requirements. Efficiency mode should be used only after the inverter has been warmed up to operating temperature.

1. To turn on the efficiency mode, press the switch to the ON position).
2. If no load is present, the inverter RPM will drop down to an idle speed.
3. As a load is applied, the inverter will sense the load and engine RPM will increase according to the load applied.
4. To run the inverter at maximum power and RPM, press the efficiency mode switch to the OFF position.

RESETTING THE RESET BREAKER

The inverter will trip the breaker and automatically disconnect from the load when the controls sense a predetermined overload condition. The inverter engine will continue to run, but there will not be any electrical output.

1. Turn off all devices and unplug them from the inverter.
2. Determine the wattage required from the devices being powered by the inverter. Make sure the wattage required does not exceed the maximum output of the inverter.
3. Press in the reset breaker to reset it (see Figure 10).

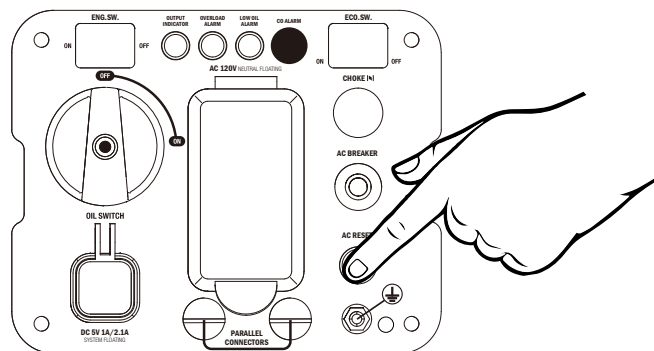

Figure 10: Press in reset breaker

4. Plug the devices in to the inverter.
5. Turn on the devices as needed.

MAINTENANCE



BEFORE PERFORMING MAINTENANCE ON THE INVERTER, REVIEW THE SAFETY SECTION STARTING ON PAGE 5, AS WELL AS THE FOLLOWING SAFETY MESSAGES.

⚠ WARNING	
	Avoid accidentally starting the inverter during maintenance by removing the spark plug boot from the spark plug. For electric start inverters, also disconnect the battery cables from the battery (disconnect the black negative (-) cable first) and place the cables away from the battery posts to avoid arcing.
	Allow hot components to cool to the touch prior to performing any maintenance procedure.
	Internal pressure can build in the engine crankcase while the engine is running. Removing the oil fill plug/dipstick while the engine is hot can cause extremely hot oil to spray out of the crankcase and can severely burn skin. Allow engine oil to cool for several minutes before removing the oil fill plug/dipstick.
	Always perform maintenance in a well-ventilated area. Gasoline fuel and fuel vapors are extremely flammable and can ignite under certain conditions.

⚠ CAUTION	
	Avoid skin contact with engine oil or gasoline. Prolonged skin contact with engine oil or gasoline can be harmful. Frequent and prolonged contact with engine oil may cause skin cancer. Take protective measures and wear protective clothing and equipment. Wash all exposed skin with soap and water.

⚠ WARNING	
	Failure to perform periodic maintenance or not following maintenance procedures can cause the inverter to malfunction and could result in death or serious injury.

NOTICE	
Periodic maintenance intervals vary depending on inverter operating conditions. Operating the inverter under severe conditions, such as sustained high-load, high-temperature, or unusually wet or dusty environments, will require more frequent periodic maintenance. The intervals listed in the maintenance schedule should be treated only as a general guideline.	

Following the maintenance schedule is important to keep the inverter in good operating condition. The following is a summary of maintenance items by periodic maintenance intervals.

TABLE 1: MAINTENANCE SCHEDULE - OWNER PERFORMED

Maintenance Item	Before Every Use	After First 20 Hours or First Month of Use	After 50 Hours of Use or Every 6 Months	After 100 Hour of Use or Every 6 Months	After 300 Hours of Use or Every Year
Engine Oil	Check Level	Change	Change	-	-
Cooling Features	Check/Clean	-	-	-	-
Air Filter	Check	-	Clean*	-	Replace
Spark Plug	-	-	-	Check/Clean	Replace
Spark Arrestor	-	-	-	Check/Clean	-

*Service more frequently if operating in dry and dusty conditions

MAINTENANCE

ENGINE OIL MAINTENANCE

Engine Oil Specification

1. Only use the engine oil specified in Figure 11.
2. Only use 4-stroke/cycle engine oil. **NEVER USE 2-STROKE/CYCLE OIL.** Synthetic oil is an acceptable substitute for conventional oil.

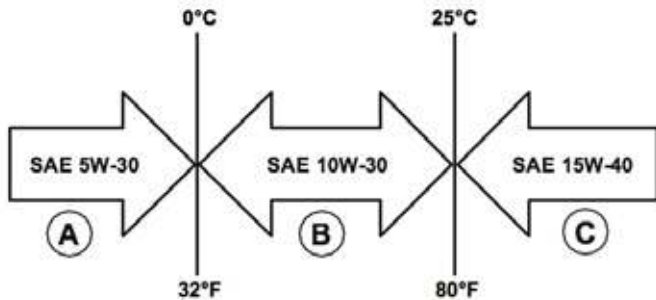

Figure 11: Recommended Oil

CHECKING ENGINE OIL

NOTICE

Always maintain proper engine oil level. Failure to maintain proper engine oil level could result in severe damage to the engine and/or shorten the life of the engine.

Always use the specified engine oil. Failure to use the specified engine oil can cause accelerated wear and/or shorten the life of the engine.

Engine oil level should be checked before every use.

1. Always operate or maintain the inverter on a flat surface.
2. Stop engine if running.
3. Let engine sit and cool for several minutes (allow crankcase pressure to equalize).
4. Remove the engine service panel to access the oil fill/drain plug.
5. With a damp rag, clean around the oil fill/drain plug.
6. Remove the oil fill/drain plug.
7. Check oil level: When checking the engine oil, remove the oil fill/ drain plug.
 - The oil level is acceptable if oil is visible at the bottom of the threads of the oil fill plug.
 - If oil level is low, add to the correct level using the supplied oil fill bottle. Do not overfill the oil crankcase.

NOTICE

Engine oil must always be checked and added when the inverter is on a flat, level surface, or an inaccurate reading may result, causing serious engine damage.

ADDING ENGINE OIL

1. Always operate or maintain the inverter on a flat surface.
2. Stop engine if running.
3. Let engine sit and cool for several minutes (allow crankcase pressure to equalize).
4. Remove the engine service panel to gain access to the oil fill/drain plug.
5. Thoroughly clean around the oil fill/drain plug.
6. Remove the oil fill/drain plug.
7. Select the proper engine oil as specified in Figure 11.
8. Using the supplied oil funnel, slowly add engine oil to the engine. Stop frequently to check the oil level and avoid overfilling.

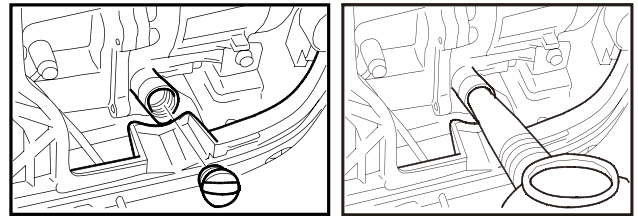

9. Continue to add oil until the oil is at the correct level.

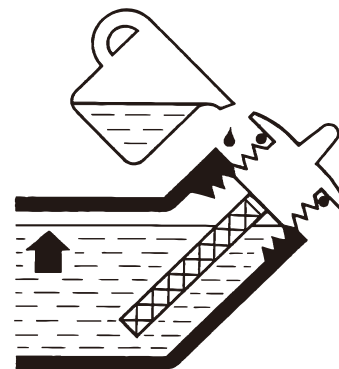

MAINTENANCE

CHANGING ENGINE OIL

1. Stop the engine.
2. Let engine sit and cool for several minutes (allow crankcase pressure to equalize).
3. Remove the engine service panel to gain access to the oil fill/drain plug.
4. Place oil pan (or suitable container) under the oil fill/drain plug (see Figure 12).

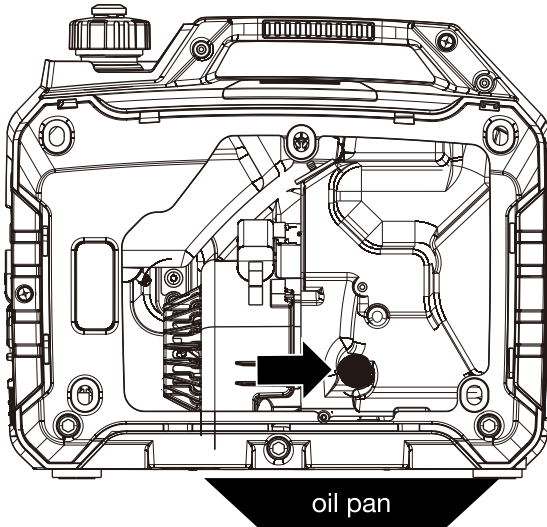
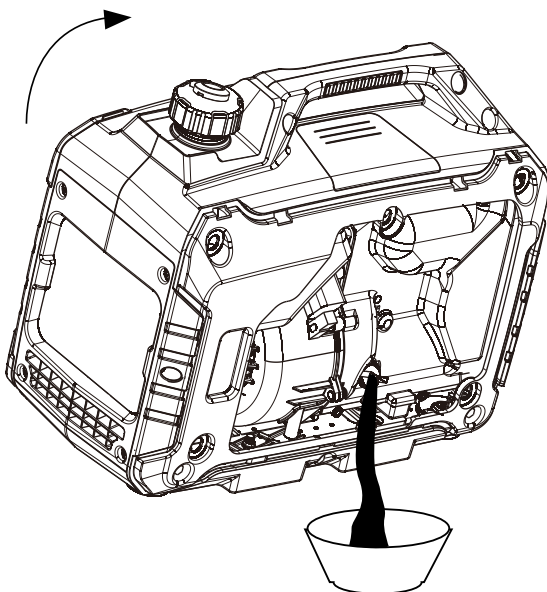

Figure 12: Place oil pan under oil fill/drain plug

5. With a damp rag, thoroughly clean around the oil fill/drain plug.
6. Tilt the inverter so the oil drains down the through into the container.



: Carefully tip inverter so oil flows into oil pan

7. Allow oil to completely drain.
8. Fill crankcase with oil following the steps outlined in *Adding Engine Oil* on page 18.
9. Dispose of used engine oil properly.

NOTICE

Never dispose of used engine oil by dumping the oil into a sewer, on the ground, or into groundwater or waterways. Always be environmentally responsible. Follow the guidelines of the EPA or other governmental agencies for proper disposal of hazardous materials. Consult local authorities or reclamation facility.

AIR FILTER MAINTENANCE

WARNING



Never use gasoline or other flammable solvents to clean the air filter. Use only household detergent soap to clean the air filter.

Cleaning the Air Filter

The air filter must be cleaned after every 50 hours of use or 3 months (frequency should be increased if inverter is operated in a dusty environment).

1. Turn off the inverter and let it cool for several minutes if running.
2. Remove the engine service panel to gain access to the air filter.
3. Unscrew the air cleaner cover and tip the cover down (see Figure 14).
4. Remove the foam element from the air cleaner housing.

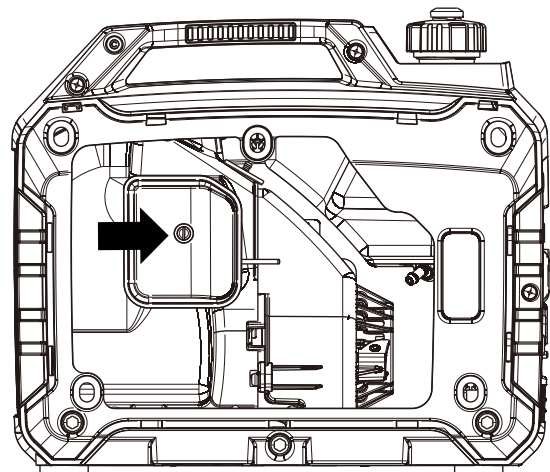

Figure 14: Unscrew air cleaner cover

MAINTENANCE

5. Wash the foam air filter element by submerging the element in a solution of household detergent soap and warm water. Slowly squeeze the foam to thoroughly clean.

NOTICE

NEVER twist or tear the foam air filter element during cleaning or drying. Only apply slow but firm squeezing action.

6. Rinse in clean water by submerging the air filter element in fresh water and applying a slow squeezing action (see Figure 15).



Figure 15

NOTICE

Never dispose of soap cleaning solution used to clean the air filter by dumping the solution into a sewer, on the ground, or into ground water or waterways. Always be environmentally responsible. Follow the guidelines of the EPA or other governmental agencies for proper disposal of hazardous materials. Consult local authorities or reclamation facility.

7. Dispose of used soap cleaning solution properly.
8. Dry the air filter element by again applying a slow firm squeezing action.
9. Return the air filter element to its position in the air cleaner housing.
10. Install the air cleaner cover, making sure the tabs lock into place.
11. Install the engine service panel.

DRAINING THE FLOAT BOWL

1. Remove the engine service panel to access the carburetor.
2. Locate the clear plastic hose from the float that is exiting out the bottom of the inverter, and place a suitable container under it to catch the drained fuel (see Figure 16).

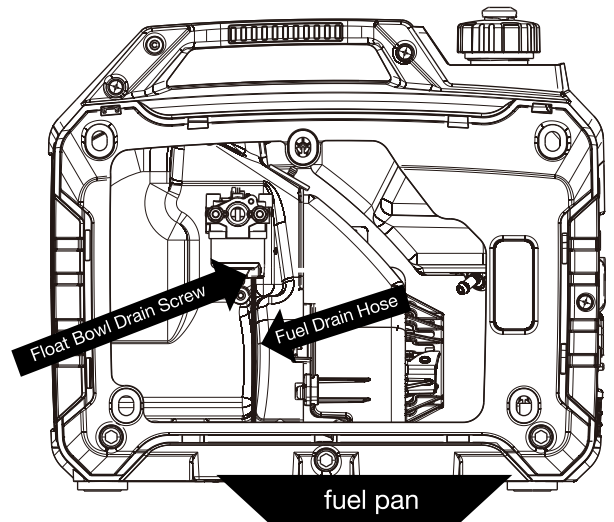

Figure 16: Fuel drain hose

3. Loosen the float bowl drain screw (see Figure 17) until fuel is seen draining from the float bowl.

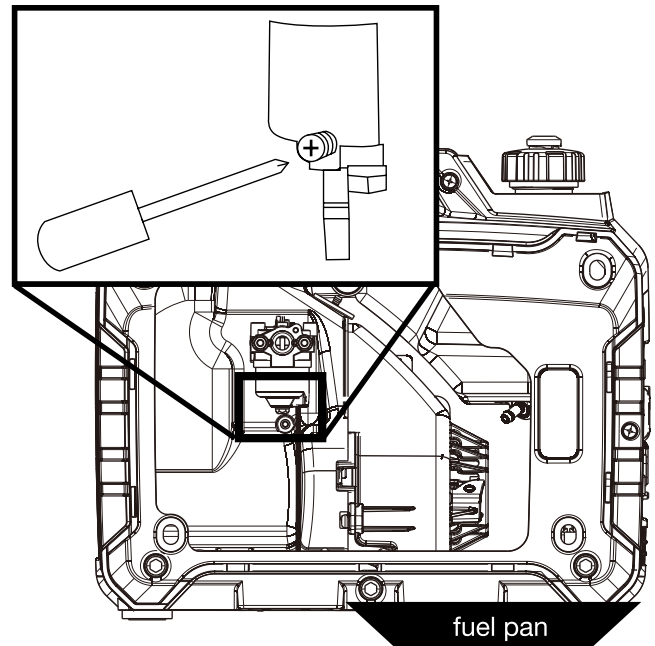

Figure 17: Loosen float bowl screw

4. Allow fuel to drain into the container, and then tighten the float bowl drain screw.

NOTICE

Never dispose of fuel by dumping fuel into a sewer, on the ground, or into groundwater or waterways. Always be environmentally responsible. Follow the guidelines of the EPA or other governmental agencies for proper disposal of hazardous materials. Consult local authorities or reclamation facility.

5. Install the engine service panel.

MAINTENANCE

SPARK PLUG MAINTENANCE

The spark plug must be checked and cleaned after every 100 hours of use or 6 months and must be replaced after 300 hours of use or every year.

1. Stop the inverter and let it cool for several minutes if running.
2. Move the inverter to a flat, level surface.
3. Slide the spark plug access cover off the housing (see Figure 18)

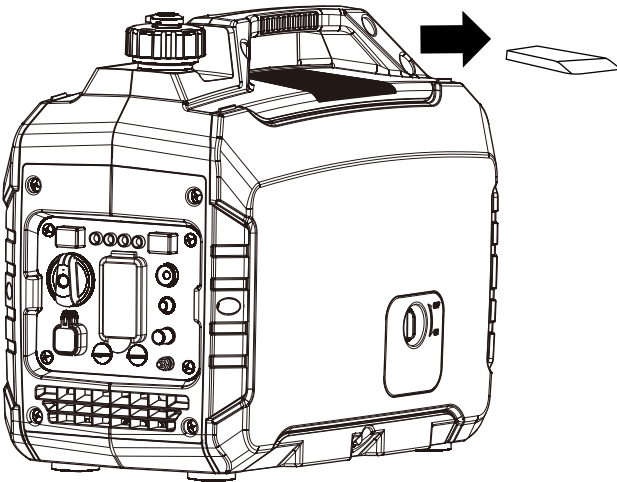

Figure 18: Slide off spark plug cover

4. Remove the spark plug boot by firmly pulling the plastic spark plug boot handle directly away from the engine.

NOTICE

Never apply any side load or move the spark plug laterally when removing the spark plug. Applying a side load or moving the spark plug laterally may crack and damage the spark plug boot.

5. Clean area around the spark plug.
6. Using the spark plug socket wrench provided, remove the spark plug from the cylinder head (see Figure 19).

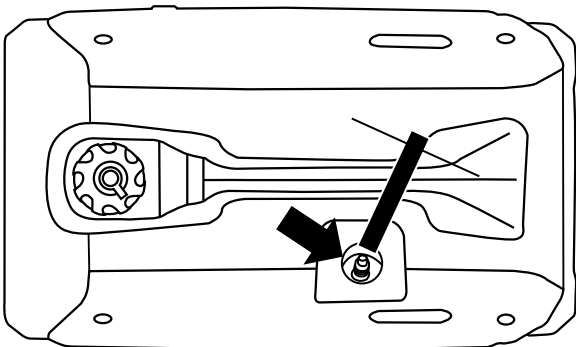
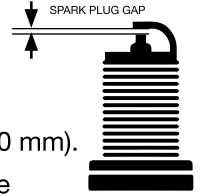

Figure 19: Remove spark plug with socket wrench

7. Place a clean rag over the opening created by the removal of the spark plug to make sure no dirt can get into the combustion chamber.

8. Inspect the spark plug for:

- Cracked or chipped insulator
- Excessive wear
- Spark plug gap of 0.032 in. (0.80 mm).



If the spark plug fails any one of the conditions listed above, replace the plug.

NOTICE

Only use the recommended spark plug. See chart below. Using a non-recommended spark plug could result in damage to the engine.

9. Install the spark plug by carefully following the steps outlined below:
 - a. Carefully insert the spark plug back into the cylinder head. Hand-thread the spark plug until it bottoms out.
 - b. Using the spark plug socket wrench provided, turn the spark plug to ensure it is fully seated.
 - c. Replace the spark plug boot, making sure the boot fully engages the spark plug's tip.
 - d. Install the spark plug access cover.

MAINTENANCE

CLEANING THE SPARK ARRESTOR

Check and clean the spark arrestor after every 100 hours of use or 6 months.

1. Stop the inverter and let it cool for several minutes if running.
2. Move the inverter to a flat, level surface.
3. Remove the screws holding the muffler cover in place (see Figure 20).

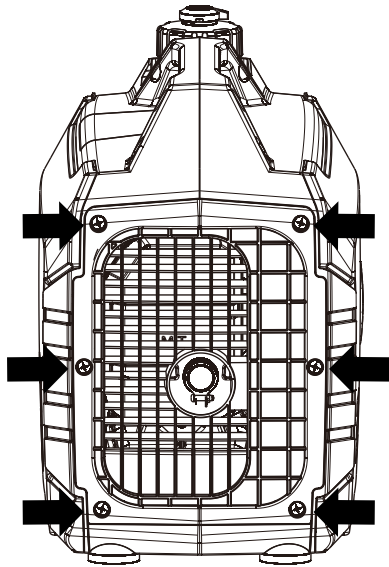

Figure 20: Remove screws holding muffler cover

4. Loosen the clamp holding the spark arrestor onto the muffler.
5. Slide the spark arrestor band clamp off the spark arrestor screen.
6. Pull the spark arrestor screen off the muffler exhaust pipe.
7. Using a wire brush, remove any dirt and debris that may have collected on the spark arrestor screen.
8. If the spark arrestor screen shows signs of wear (rips, tears or large openings in the screen), replace the spark arrestor screen.
9. Install the spark arrestor components in the following order:
 - a. Place spark arrestor screen over the muffler exhaust pipe. Push on the screen until it fully bottoms out.
 - b. Place the spark arrestor band clamp over the screen and tighten with a flathead screwdriver
10. Replace the discharge gate.

CLEANING THE INVERTER

It is important to inspect and clean the inverter before every use.

Clean All Engine Air Inlet and Outlet Ports – Make sure all engine air inlet and outlet ports are clean of any dirt and debris to ensure the engine does not run hot.

STORAGE

⚠ WARNING



Never store an inverter with fuel in the tank indoors or in a poorly ventilated area where the fumes can come in contact with an ignition source such as a: 1) pilot light of a stove, water heater, clothes dryer or any other gas appliance; or 2) spark from an electric appliance.

NOTICE

Gasoline stored for as little as 60 days can go bad, causing gum, varnish and corrosive buildup in fuel lines, fuel passages and the engine. This corrosive buildup restricts the flow of fuel, preventing an engine from starting after a prolonged storage period.

Proper care should be taken to prepare the inverter for any storage

1. Clean the inverter as outlined in *Cleaning the Inverter*.
2. Siphon all gasoline from the fuel tank as best as possible.
3. Start the engine and allow the inverter to run until all the remaining gasoline in the fuel lines and carburetor is consumed and the engine shuts off.
4. Drain any remaining fuel from the float bowl. See *Draining the Float Bowl* on page 20.
5. Change the oil (see *Changing Engine Oil* on page 19).
6. Remove the spark plug (see *Spark Plug Maintenance* on page 21) and place about 1 tablespoon of oil in the spark plug opening. While placing a clean rag over the spark plug opening, slowly pull the recoil handle to allow the engine to turn over several times. This will distribute the oil and protect the cylinder wall from corroding during storage.
7. Replace the spark plug (see *Spark Plug Maintenance* on page 21).
8. Move the inverter to a clean, dry place for storage.

TROUBLESHOOTING

⚠ WARNING



Before attempting to service or troubleshoot the generator, the owner or service technician must first read the owner's manual and understand and follow all safety instructions. Failure to follow all instructions may result in conditions that can lead to voiding of the EPA certification or product warranty, serious personal injury, property damage or even death.

PROBLEM	POTENTIAL CAUSE	SOLUTION
Engine is running, but no electrical output.	1. Reset breaker is tripped.	1. Reset the reset breaker (see page 16).
	2. The power cord's plug connector is not fully engaged in the inverter's outlet.	2. Verify plug connector is firmly engaged in the inverter's outlet.
	3. Faulty or defective power cord	3. Replace power cord.
	4. Faulty or defective electrical appliance	4. Try connecting a known good appliance to verify the inverter is producing electrical power.
Engine will not start or remain running while trying to start.	1. Inverter is out of gasoline.	1. Add gasoline to the inverter (see page 14).
	2. Fuel flow is obstructed.	2. Inspect and clean fuel delivery passages.
	3. Dirty air filter	3. Check and clean the air filter (see page 19).
	4. Low oil level shutdown switch is preventing the unit from starting.	4. Check oil level and add oil if necessary (see page 18).
	5. Spark plug boot is not fully engaged with the spark plug tip.	5. Firmly push down on the spark plug boot to ensure the boot is fully engaged.
	6. Spark plug is faulty.	6. Remove and check the spark plug. Replace if faulty (see pages 21).
	7. Dirty/plugged spark arrestor	7. Check and clean the spark arrestor (see page 22).
	8. Stale fuel	8. Drain fuel and replace with fresh fuel.
Inverter suddenly stops running.	1. Inverter is out of fuel.	1. Check fuel level (see page 14). Add fuel if necessary.
	2. The low oil shut down switch has stopped the engine.	2. Check oil level and add oil if necessary (see page 18).
	3. Too much load	3. Restart the inverter and reduce the load.
Engine runs erratic; does not hold a steady RPM.	1. Choke was left in the CHOKE position.	1. Move choke to the RUN position
	2. Dirty air filter	2. Clean the air filter (see page 19).
	3. Applied loads maybe cycling on and off	3. As applied loads cycle, changes in engine speed may occur; this is a normal condition.

GM2000i SCHEMATICS

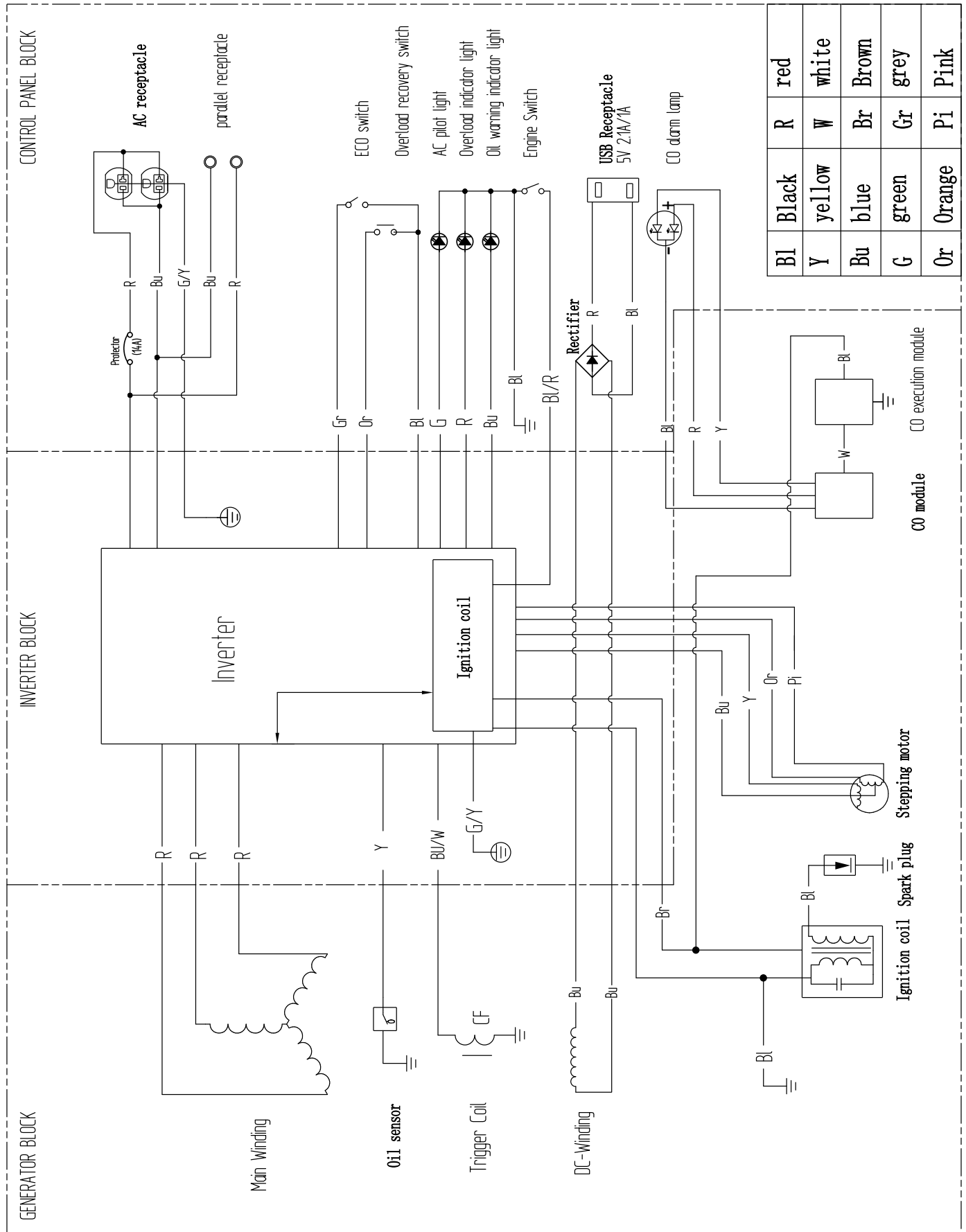

GENMAX®

**CHONGQING DINKING POWER MACHINERY CO.,LTD.
CAOJIE DEVELOPMENT AREA, INDUSTRIAL PARK, HECHUAN, CHONGQING, CHINA**

6800.452.GEM.02.00 V3