

GENERAC®

Protector™ Series

Owner's Manual Stationary Diesel Generators

Residential and Commercial

15–50 kW, 12–40 kVA

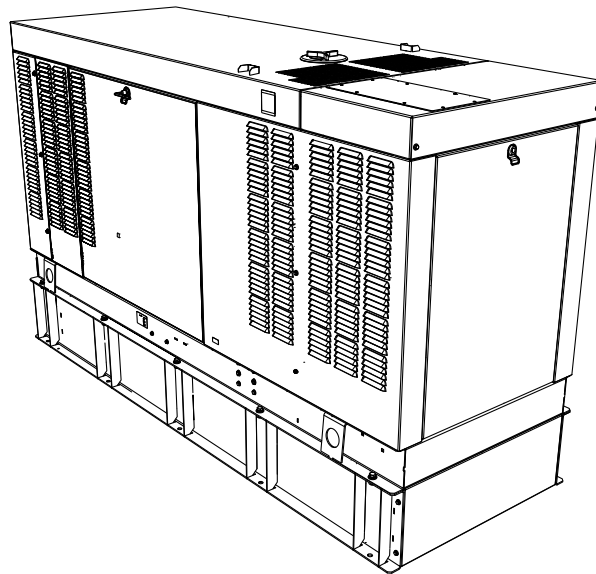

WARNING

Loss of life. This product is not intended to be used in a critical life support application. Failure to adhere to this warning could result in death or serious injury. (000209b)

Register your Generac product at:

WWW.GENERAC.COM

1-888-GENERAC

(888-436-3722)

Para español , visita: <http://www.generac.com/service-support/product-support-lookup>

Pour le français, visiter : <http://www.generac.com/service-support/product-support-lookup>

Para portugues, visite: <http://www.generac.com/service-support/product-support-lookup>

Найти версию на русском языке: <http://www.generac.com/service-support/product-support-lookup>

SAVE THIS MANUAL FOR FUTURE REFERENCE

Use this page to record important information about the generator.

For quick and easy reference, copy the information printed on the Unit Identification Label into the table provided below. The Unit Identification Label is located on the left engine mount on 15/20 kW (2.5L) models, on the left side of the radiator shroud on 30 kW (2.2L) models, and on the left side of the engine support rail on 48/50 kW (3.3L) models. The label provides the following information:

Model Number	
Serial Number	
Rated KW or kVA	
Voltage Rating	
Maximum Current Rating (AMPS)	

GENERAC

GENERATOR UNIT

GEN MODEL:

MODEL:

SERIAL:

ALTERNATE:

PROD DATE:

COUNTRY OF ORIGIN: USA

GENERATOR DATA

250 KW 313 KVA 60 HZ 0.8 PF
 UPSIZE ALT 0 KW 0 KVA
 120/240 VOLT 7517 / .0 AMP
 1800 ENG RPM 1800 ALT RPM
 BREAKER 260 KW 800 AMP
 X'D 0.23 X'D 0.20

3 PHASE DELTA
 UNBALANCED LOAD CAPACITY-25%

ROTOR H STATOR H CLASS
 WINDINGS @ 40°C AMBIENT TEMP

MANUF.
 LOC.
 EAGLE, WI

THIS PRODUCT OR ITS COMPONENTS IS COVERED BY THE FOLLOWING PATENT: US 7,230,345

GENERAC POWER SYSTEMS, INC
 WAUKESHA, WI USA

OK0876

SAMPLE LABEL

006366

Always provide the complete model number and serial number when contacting an Independent Authorized Service Dealer (IASD) about parts and/or service.

Operation and Maintenance: Correct maintenance and care of the unit ensures a minimum number of problems, and keeps operating expenses at a minimum. It is the operator's responsibility to perform all safety inspections, to verify all maintenance for safe operation is performed promptly, and to have the equipment inspected periodically by an IASD. Normal maintenance, service, and replacement of parts are the responsibility of the owner/operator and are not considered defects in materials or workmanship within the terms of the warranty. Individual operating habits and usage may contribute to the need for additional maintenance or service.

Contact an IASD for assistance when the generator requires servicing or repairs. IASDs are factory-trained and are capable of handling all service needs.

INDEPENDENT AUTHORIZED SERVICE DEALER LOCATION

To locate the nearest INDEPENDENT AUTHORIZED SERVICE DEALER, please call this number:
1-800-333-1322

or visit the dealer locator at:
www.generac.com/Service/DealerLocator/

WARNING

CANCER AND REPRODUCTIVE HARM
www.P65Warnings.ca.gov

(000393a)

WARNING

Breathing diesel engine exhaust exposes you to chemicals known to the State of California to cause cancer and birth defects or other reproductive harm.

- Always start and operate the engine in a well-ventilated area.
- If in an enclosed area, vent the exhaust to the outside.
- Do not modify or tamper with the exhaust system.
- Do not idle the engine except as necessary.

For more information go to
www.P65Warnings.ca.gov/diesel (000394)

Table of Contents

Section 1: Safety Rules & General Information

Introduction	1
Read This Manual Thoroughly	1
Safety Rules	1
How to Obtain Service	1
General Hazards	2
Exhaust Hazards	2
Electrical Hazards	3
Fire Hazards	3
Explosion Hazards	3

Section 2: Specifications

Emission Information	5
Emissions Data Plate	5
Specifications	6
Engine	6
Engine Oil Recommendations	7
Coolant Water Treatment	7
Fuel Requirements	7
Fuel Maintenance	7
Corrosion Protection	7
Battery Requirements	8
Battery Charger	8
Battery Disposal	8
Accessories	8

Section 3: Activation and Startup

Introduction	11
Orientation	11
Removing Side Access Panels	11
Priming Fuel System	11
Installing Battery (2.5L Models)	12
Opening Viewing Window	13
Starting and Running Engine	13
Testing Auxiliary Shutdown Switch Operation	13
Activate Unit	14
Operational Checks	15
Self Test	15
Checking Manual Transfer Switch Operation	15
Electrical Checks	15
Testing Generator Under Load	16
Checking Automatic Operation	16

Final Instructions	17
Shutting Generator Down While Under Load or During a Utility Outage	17

Section 4: Operation

Control Panel	19
AUTO/MANUAL/OFF	20
Menu Navigation	20
Alarm/Warning Conditions	22
Changing Time and Date	22
Programmable Timers	22
Dealer Programmable	22
User Programmable	22
USB Port for Firmware Updates	22
Battery Charger	23
Transfer Switch Automatic Operation	23
Automatic Sequence of Operation	23
Transfer Switch Manual Operation	24
Transfer to Generator Power	24
Transfer Back to Utility Power	24

Section 5: Maintenance

Component Locations	25
Access Panels	27
Removal	27
Installation	27
Service Maintenance Intervals	27
Remove From Service	28
30 Hour Break-In	29
Daily Maintenance (If Running Continuously)	29
Schedule A Maintenance	29
Preliminary Instructions	29
Checking Fuel Level and Fill	29
Draining Fuel Filter and Inspect Fuel Lines/Hoses	30
Inspecting Coolant Level and Hoses	30
Checking Radiator for Clogging	30
Checking Lubricating Oil Level	31
Checking Battery Condition/Fluid Level	31
Battery Replacement	32
Inspecting and Adjusting V-Belt	33
Adjusting V-Belt Tension	33
Replacing Air Filter Element—2.5L Engine	34
Replacing Air Filter Element—2.2L Engine	34

Replacing Air Filter Element—3.3L Engine 35

**Lubricating Governor Rod Linkage
(2.5L and 3.3L Engines) 35**

 Final Instructions 35

Schedule B Maintenance 35

 Replacing Lubricating Oil and Oil Filter 35

 Draining Fuel Filter and Inspecting Fuel
 Lines/Hoses 36

 Priming Fuel System 36

 Draining/Flushing Coolant System 37

 Final Instructions 37

Schedule C Maintenance 37

Return To Service 38

Section 6: Troubleshooting

Engine Troubleshooting 39

Controller Troubleshooting 40

**Removal From Service During Utility
Outages 41**

 Remove From Service 41

 Return to Service 41

Storage 41

 Prepare For Storage 41

 Return to Service From Storage 42

Attention After Submersion 42

Attention After Fuel Spillage 42

Contaminated Fuel Disposal 42

Section 1: Safety Rules & General Information

Introduction

Thank you for purchasing this stationary automatic standby generator. This generator is designed to automatically supply electrical power to operate critical loads during a utility power failure. The unit is factory installed in an all-weather metal enclosure and **is intended exclusively for outdoor installation** using only diesel fuel.

NOTE: This generator is suitable for supplying typical residential/commercial loads, such as induction motors (sump pumps, refrigerators, freezers, air conditioners, furnaces, etc.), electronic components (computers, monitors, televisions, etc.), lighting, microwaves, and other residential and business loads, when sized correctly.

The information in this manual is accurate based on products produced at the time of publication. The manufacturer reserves the right to make technical updates, corrections, and product revisions at any time without notice.

Read This Manual Thoroughly



WARNING

Consult Manual. Read and understand manual completely before using product. Failure to completely understand manual and product could result in death or serious injury. (000100a)

If any section of this manual is not understood, contact the nearest Independent Authorized Service Dealer (IASD) or Generac Customer Service at 1-888-436-3722 (1-888-GENERAC), or visit www.generac.com for starting, operating, and servicing procedures. The owner is responsible for correct maintenance and safe use of the unit.

This manual must be used in conjunction with all other supporting product documentation supplied with the product.

SAVE THESE INSTRUCTIONS for future reference. This manual contains important instructions that must be followed during placement, operation, and maintenance of the unit and its components. Always supply this manual to any individual that will use this unit, and instruct them on how to correctly start, operate, and stop the unit in case of emergency.

Safety Rules

The manufacturer cannot anticipate every possible circumstance that might involve a hazard. The alerts in this manual, and on tags and decals affixed to the unit, are not all inclusive. If using a procedure, work method, or operating technique that the manufacturer does not specifically recommend, verify that it is safe for others and does not render the equipment unsafe.

Throughout this publication, and on tags and decals affixed to the unit, DANGER, WARNING, CAUTION, and NOTE blocks are used to alert personnel to special instructions about a particular operation that may be hazardous if performed incorrectly or carelessly. Observe them carefully. Alert definitions are as follows:

DANGER

Indicates a hazardous situation which, if not avoided, will result in death or serious injury.

(000001)

WARNING

Indicates a hazardous situation which, if not avoided, could result in death or serious injury.

(000002)

CAUTION

Indicates a hazardous situation which, if not avoided, could result in minor or moderate injury.

(000003)

NOTE: Notes contain additional information important to a procedure and will be found within the regular text of this manual.

These safety alerts cannot eliminate the hazards that they indicate. Common sense and strict compliance with the special instructions while performing the action or service are essential to preventing accidents.

How to Obtain Service

When the unit requires servicing or repairs, contact Generac Customer Service at 1-888-GENERAC (1-888-436-3722) or visit www.generac.com for assistance.

When contacting Generac Customer Service about parts and service, always supply the complete model and serial number of the unit as given on its data decal located on the unit. Record the model and serial numbers in the spaces provided on the front cover of this manual.

General Hazards

⚠ DANGER

Loss of life. Property damage. Installation must always comply with applicable codes, standards, laws and regulations. Failure to do so will result in death or serious injury. (000190)

⚠ WARNING

Electric shock. Only a trained and licensed electrician should perform wiring and connections to unit. Failure to follow proper installation requirements could result in death, serious injury, and equipment or property damage. (000155a)



⚠ WARNING

Moving Parts. Keep clothing, hair, and appendages away from moving parts. Failure to do so could result in death or serious injury. (000111)



⚠ WARNING

Moving Parts. Do not wear jewelry when starting or operating this product. Wearing jewelry while starting or operating this product could result in death or serious injury. (000115)

⚠ WARNING

Risk of injury. Do not operate or service this machine if not fully alert. Fatigue can impair the ability to service this equipment and could result in death or serious injury. (000215)

⚠ WARNING

Accidental Start-up. Disconnect the negative battery cable, then the positive battery cable when working on unit. Failure to do so could result in death or serious injury. (000130)

⚠ WARNING

Injury and equipment damage. Do not use generator as a step. Doing so could result in falling, damaged parts, unsafe equipment operation, and could result in death or serious injury. (000216)

⚠ WARNING

Equipment damage. This unit is not intended for use as a prime power source. It is intended for use as an intermediate power supply in the event of temporary power outage only. Doing so could result in death, serious injury, and equipment damage. (000247a)



⚠ WARNING

Loss of life. This product is not intended to be used in a critical life support application. Failure to adhere to this warning could result in death or serious injury. (000209b)

Exhaust Hazards



⚠ DANGER

Asphyxiation. Carbon monoxide can kill in minutes. Operate this unit outdoors only. Failure to do so will cause death or serious injury. (000525)



⚠ DANGER

Asphyxiation. Running engines produce carbon monoxide, a colorless, odorless, poisonous gas. Carbon monoxide, if not avoided, will result in death or serious injury. (000103)



⚠ WARNING

Asphyxiation. Always use a battery operated carbon monoxide alarm indoors and installed according to the manufacturer's instructions. Failure to do so could result in death or serious injury. (000178a)

⚠ WARNING

Equipment and property damage. Do not alter construction of, installation, or block ventilation for generator. Failure to do so could result in unsafe operation or damage to the generator. (000146)

Electrical Hazards



⚠ DANGER

Electrocution. Contact with bare wires, terminals, and connections while generator is running will result in death or serious injury.

(000144)



⚠ DANGER

Electrocution. Water contact with a power source, if not avoided, will result in death or serious injury.

(000104)



⚠ DANGER

Electrocution. Do not wear jewelry while working on this equipment. Doing so will result in death or serious injury.

(000188)



⚠ DANGER

Electrocution. In the event of electrical accident, immediately shut power OFF. Use non-conductive implements to free victim from live conductor. Apply first aid and get medical help. Failure to do so will result in death or serious injury.

(000145)

- Generator may crank and start at any time when utility power is lost. When this occurs, load circuits are transferred to STANDBY (generator) power source. Before working on generator, always set generator main line circuit breaker (MLCB) (generator disconnect) to OFF (OPEN), press OFF button on control panel keypad, remove the 7.5 amp fuse, and disconnect black negative battery cable from negative (-) battery terminal.

Fire Hazards



⚠ DANGER

Explosion and fire. Fuel and vapors are extremely flammable and explosive. No leakage of fuel is permitted. Keep fire and spark away. Failure to do so will result in death or serious injury.

(000192)



⚠ WARNING

Fire and explosion. Installation must comply with all local, state, and national electrical building codes. Noncompliance could result in unsafe operation, equipment damage, death, or serious injury.

(000218)



⚠ WARNING

Fire hazard. Use only fully-charged fire extinguishers rated "ABC" by the NFPA. Discharged or improperly rated fire extinguishers will not extinguish electrical fires in automatic standby generators.

(000219)

Comply with regulations the Occupational Safety and Health Administration (OSHA) has established, or with equivalent standards. Also, verify that the unit is applied, used, and maintained in accordance with the manufacturer's instructions and recommendations. Do nothing that might alter safe application/usage and render the unit in noncompliance with the aforementioned codes, standards, laws, and regulations.

Explosion Hazards



⚠ DANGER

Explosion and fire. Fuel and vapors are extremely flammable and explosive. No leakage of fuel is permitted. Keep fire and spark away. Failure to do so will result in death or serious injury.

(000192)

NOTE: If this generator is used to power electrical load circuits normally powered by a utility power source, it is required by code to install a transfer switch. The transfer switch must effectively isolate the electrical system from the utility distribution system when the generator is operating (NEC 702). Failure to isolate an electrical system by such means will result in damage to the generator and also may result in injury or death to utility power workers due to backfeed of electrical energy.

This page intentionally left blank.

Section 2: Specifications

Emission Information

The U.S. Environmental Protection Agency (EPA) requires generators to comply with exhaust emission standards. The generator is certified to meet applicable EPA emission levels, and is certified for use as a stationary engine for standby power generation. Any other use may be a violation of federal and/or local laws. To verify the engine complies with applicable emission standards for the duration of the engine's life, it is important to follow maintenance specifications in [Maintenance](#). This generator is certified to operate on Ultra-Low Sulfur Diesel Fuel No. 2 (KSM2610).

Emissions Data Plate

See [Figure 2-1](#). A data plate is riveted to the cylinder head cover to verify compliance with EPA emissions regulations.

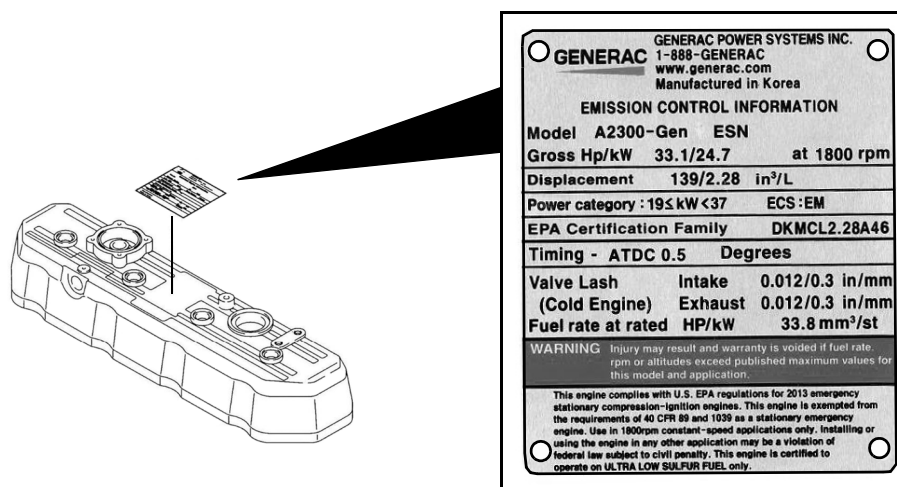

Figure 2-1. Emissions Data Plate on Cylinder Head Cover (Sample)

Specifications

Engine

General	2.5L Engine	2.2L Engine	3.3L Engine
Engine System			
Type	4 cylinder, in-line, 4 cycle		
Fuel type	Ultra low sulfur diesel		
Fuel filtering	6 Microns	25 Microns (maximum)	6 Microns
Bore and stroke	3.46 in x 4.06 in (88 mm x 103 mm)	3.30 in x 3.90 in (84 mm x 100 mm)	3.70 in x 4.72 in (94 mm x 120 mm)
Displacement	152.9 in ³ (2.51 L)	135.2 in ³ (2.22 L)	203.3 in ³ (3.33 L)
Firing order	1-3-4-2		
Direction or rotation	CCW - As viewed from flywheel		
Dimensions L x W x H	24.21 in x 19.37 in x 24.53 in (61.5 cm x 49.2 cm x 62.3 cm)	26.1 in x 19.3 in x 27.5 in (66.2 cm x 48.9 cm x 69.8 cm)	30.75 in x 23.70 in x 32.32 in (78.1 cm x 60.2 cm x 82.1 cm)
Dry weight	375 lb (170 kg)	507.1 lb (230 kg)	568.8 lb (258 kg)
Compression ratio	22 : 1	21.3 : 1	19 : 1
Cooling System			
Water pump	Pre-lubed, self-sealing		
Drive	Belt		
Thermostat	Full open temperature: 170 °F (76.5 °C)	Full open temperature: 180 °F (82 °C)	Full open temperature: 170 °F (76.5 °C)
System coolant capacity	3.0 gal (11.44 L)	2.5 gal (9.5 L)	3.0 gal (11.44 L)
Coolant flow rate	17 gal (65 L)/min at 1,800 rpm	14.8 gal (56.2 L)/min at 1,800 rpm	31.7 gal (120 L)/min at 1,800 rpm
Lubricating System			
Oil pump type	Gear		
Oil filter type	Full flow spin-on canister		
Oil cooler	Not applicable	Installed	
Crankcase capacity	6.9 qt (6.5 L)	11.2 qt (10.6 L)	11.6 qt (11.0 L)
Lubricating oil	15W-40		
Oil fill location	Filler cap on valve cover and/or front engine cover		
Oil drain location	Oil pan, bottom side		Oil filter side, bottom middle
Intake and Exhaust System			
Intake air system	Naturally aspirated	Turbocharged / aftercooled	
Maximum allowable intake restriction	7.9 in H ₂ O (1.96 kPa)	20 in H ₂ O (5.0 kPa)	10 in H ₂ O (2.49 kPa)
Maximum allowable exhaust back pressure	26.8 in H ₂ O (6.67 kPa)	41 in H ₂ O (10.2 kPa)	32 in H ₂ O (7.96 kPa)
Breather	Closed crankcase system	Open crankcase system	
Other Specifications			
Operating temperature range	-20° F to 120° F (-29° C to 49° C)		
POWER ADJUSTMENT FOR AMBIENT CONDITIONS			
Temperature deration	1.7% for every 5 °F above 77 °F or 3% for every 5 °C above 25 °C		
Altitude deration (15, 30, 48, and 50 kW)	3% for every 1,000 ft above 3,000 ft or 1% for every 100 m above 915 m		
Altitude deration (20 kW)	3% for every 1,000 ft above 1,000 ft or 1% for every 100 m above 305 m		

A complete specification sheet is included in the documentation provided with the unit at the time of purchase. Contact an IASD for additional copies.

Engine Oil Recommendations

To maintain the product warranty, the engine oil should be serviced in accordance with the recommendations of this manual. For your convenience, maintenance kits designed and intended for use on this product are available from the manufacturer that include engine oil, oil filter, air filter, spark plug(s), a shop towel and funnel. These kits can be obtained from an Independent Authorized Service Dealer (IASD).

All Generac maintenance kits meet minimum American Petroleum Institute (API) Service Class CD or better. Select the appropriate viscosity oil grade according to the expected operating temperature. After break-in, synthetic oil also can be used in the appropriate weight as standard. Once synthetic oil is used, it should be used for the life of the generator. It is not recommended to go back to a mineral oil. Do not use special additives.

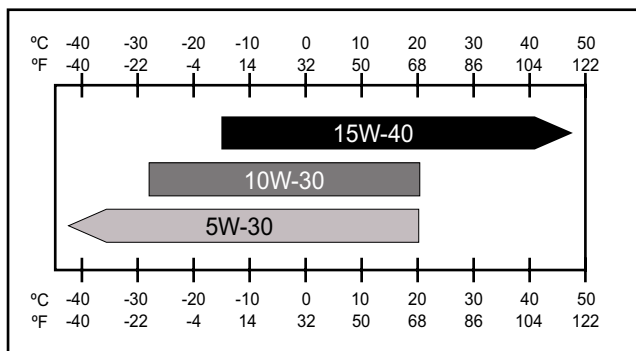

002236

Figure 2-2. Lubricating Oil Recommendations

Coolant Water Treatment



Engine damage. Use approved coolant only. Failure to do so could result in equipment damage.

(000323)

Use of incorrect coolants can damage the engine cooling system. Use demineralized water or distilled water for best results. Hard water causes scale deposits, which reduces cooling efficiency and raises internal temperatures, possibly leading to engine damage. Use an anti-corrosive to prevent rot in summer and anti-freeze to prevent freezing in winter.

Dilute anti-freeze based on a theoretical temperature which is 9–18 °F (5–10 °C) below lowest temperature expected in the area. A ratio of 40–60% is most common range.

Freezing Point °F (°C)	-13 (-25)	-31 (-35)	-58 (-50)
Coolant (% Volume)	40	50	60
Water (% Volume)	60	50	40

NOTE: Use only Peak Fleet-Charge® 50/50 ethylene glycol type coolant (available from any IASD).

IMPORTANT NOTE: Do not use propylene glycol type coolant. Using the wrong coolant, mixing different types of coolant, or even mixing different brands of the correct type of coolant, can produce unsatisfactory results, possibly leading to engine damage.

Fuel Requirements

IMPORTANT NOTE: DO NOT use home heating oil or bio-diesel fuel.

Use **No. 2D** diesel fuel when temperatures are above freezing. When temperatures are below freezing, blend **No. 1D** diesel fuel and **No. 2D** diesel fuel together for a climate adjusted fuel ratio.

- Use only Ultra-Low Sulfur Diesel fuel (ULSD)

NOTE: Low ambient temperatures as well as engine operation at high altitudes may require the use of fuels with higher Cetane ratings.

Allow at least 5% of tank capacity for fuel expansion. **DO NOT OVERFILL!**

Fuel Maintenance

Always treat diesel fuel for long term storage. Use approved fuel additive and water abatement material. Test stored fuel every 90 days and provide additional treatment if required. Periodically inspect and dry abatement material as necessary.

Corrosion Protection

Periodically wash and wax the enclosure using automotive type products. Frequent washing is recommended in salt water/coastal areas.

Battery Requirements

Group 27F, 12 Volt	2.5L Engine: For areas where temperatures regularly drop below 32 °F (0 °C).
NOTE: Battery dimensions (L x W x H) for Group 27F battery must not exceed 12-1/2 in x 6-13/16 in x 8-15/16 in (31.8 cm x 17.3 cm x 22.7 cm).	
Group 31, 12 Volt	2.2L and 3.3L Engines: For areas where temperatures regularly drop below 32 °F (0 °C).
NOTE: Battery dimensions (L x W x H) for Group 31 battery must not exceed 13 in x 6-13/16 in x 9-7/16 in (33.0 cm x 17.3 cm x 24.0 cm).	

Battery Charger

The battery charger is integrated into the control panel module. It operates as a “Smart Charger” which ensures output charging levels are safe and continuously optimized to promote maximum battery life.

Battery Disposal



Environmental Hazard. Always recycle batteries at an official recycling center in accordance with all local laws and regulations. Failure to do so could result in environmental damage, death, or serious injury. (000228)

Always recycle batteries in accordance with local laws and regulations. Contact your local solid waste collection site or recycling facility to obtain information on local recycling processes. For more information on battery recycling, visit the Battery Council International website at: <http://batterycouncil.org>

Accessories

See **Figure 2-3**. The following product accessories are available. Contact an IASD for additional information.

1. Scheduled maintenance kit (part no. G0076400; 15/20 kW)
2. Scheduled maintenance kit (part no. G0076410; 30 kW)
3. Cold weather kit (part no. G0076500: 15/20 kW; part no. G0076610: 30 kW)
4. Vent extension support kit (part no. 006588-1)
5. Fuel fill drop tube (part no. 006507-0)
6. Lockable fuel fill cap (part no. 006512-0)
7. Emergency stop switch (part no. 006510-0)
8. Touch-up paint kit (part no. 005703-0)
9. Five gallon spill box (part no. 006502-0)
10. Fuel tank risers (part no. 006505-0: 15/20 kW; part no. 006506-0: 30 kW)
11. 90% Fuel fill level alarm (part no. 006504-0)
12. Spill box drain back (part no. 006511-0)
13. Stainless steel fuel lines (part no. 006513-0:15/20 kW; part no. 006517-0: 30 kW)
14. Mobile Link[®] (part no. G006463-4) (not pictured)
15. Ultrasonic Cleaning Solution (part no. A0000018981) (not pictured)
16. All Surface Protectant (part no. A0000019001) (not pictured)



Figure 2-3. Product Accessories

This page intentionally left blank.

Section 3: Activation and Startup

Introduction

NOTE: Unit fuel tank may need to be inspected before startup by the local authority having jurisdiction (AHJ) or fire marshal to meet all requirements. User must fill fuel tank and treat the fuel according to additive specifications.

Orientation

NOTE: The 2.2L unit is depicted in most of the artwork used in this manual. Location and appearance of some components may vary between engine models.

See [Figure 3-1](#). The side of enclosure with viewing window (A) is identified as the rear of the generator. The right and left sides are identified by standing at the rear and looking towards front of unit. The battery (B) and fuel priming pump (C) are located on side of unit.

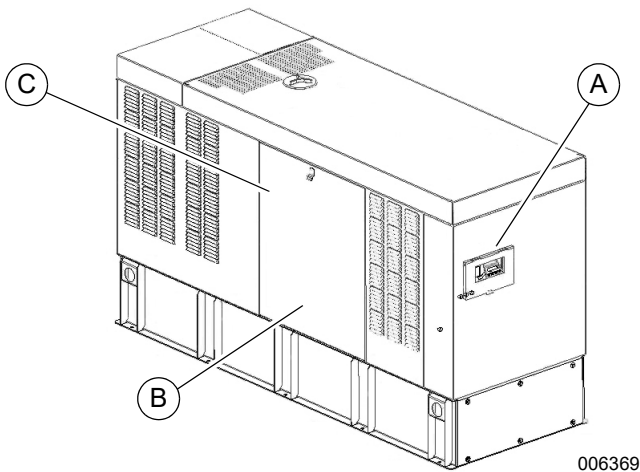

006369

Figure 3-1. Enclosure (Rear Left View)

Removing Side Access Panels

NOTE: Access panels are located at both front and sides of enclosure.

See [Figure 3-2](#). Insert key (B) into latch (A) and turn counterclockwise one-half turn and raise side access panel using thumb latch.

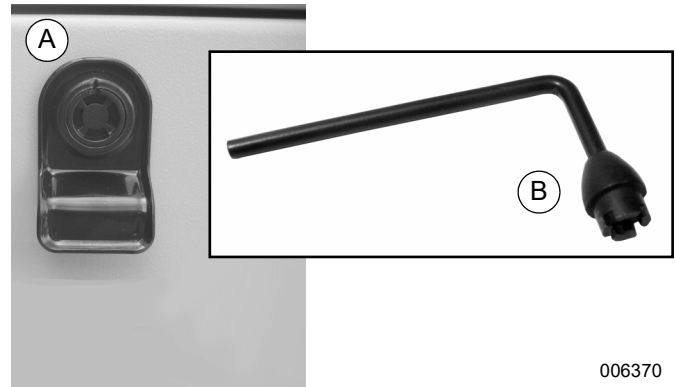

006370

Figure 3-2. Access Panel Key

Priming Fuel System

NOTE: The 2.2L engine is equipped with a rubber hand priming bulb. Some 2.2L models may be equipped with a remote stainless steel hand primer pump with a pushbutton.

NOTE: The 3.3L engine primer pump and air bleed screw are located above the fuel filter.

Proceed as follows to prime fuel system:

1. See [Figure 3-3](#) and, if applicable, [Figure 3-4](#). Loosen fuel filter air bleed screw (A) and work priming pump (B), or priming bulb, until bubbles are observed.



006188

Figure 3-3. Fuel Filter Air Bleed Screw

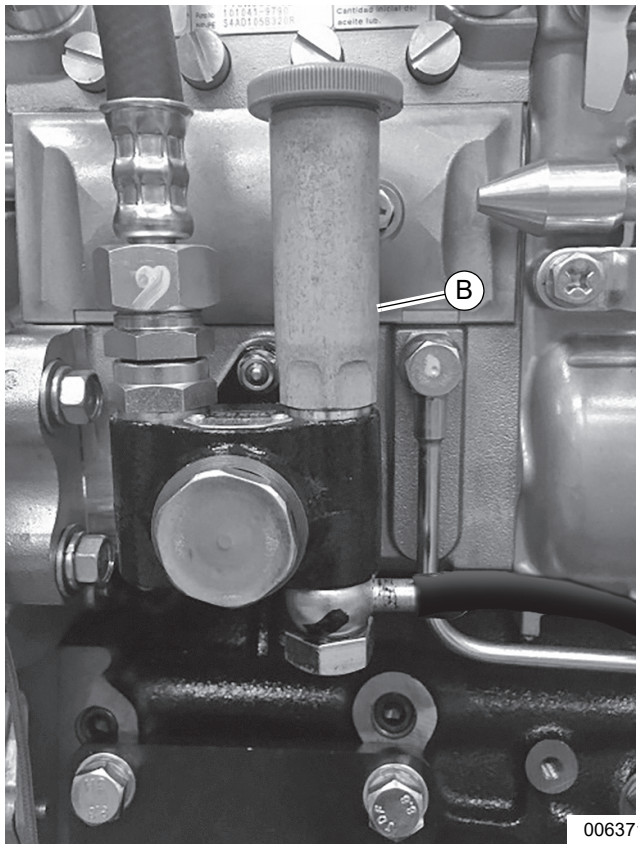

Figure 3-4. Prime Fuel System (2.5L Engines)

2. When all bubbles are purged and replaced by a solid stream of fuel, lower pump handle (or release priming bulb) and tighten the fuel filter air bleed screw.

Installing Battery (2.5L Models)



WARNING

Explosion. Batteries emit explosive gases. Always connect positive battery cable first to avoid spark. Failure to do so could result in death or serious injury.

(000133)

NOTE: Remove 10 screws to release louvered air intake panel on left side of enclosure.

Proceed as follows to install battery:

1. Loosen two screws with nylon washers to release hold-down clamp from battery tray, or loosen strap and move away from tray.
2. See [Figure 3-5](#). Place battery (C) on tray.

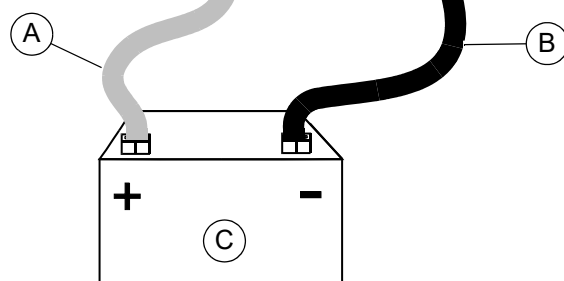
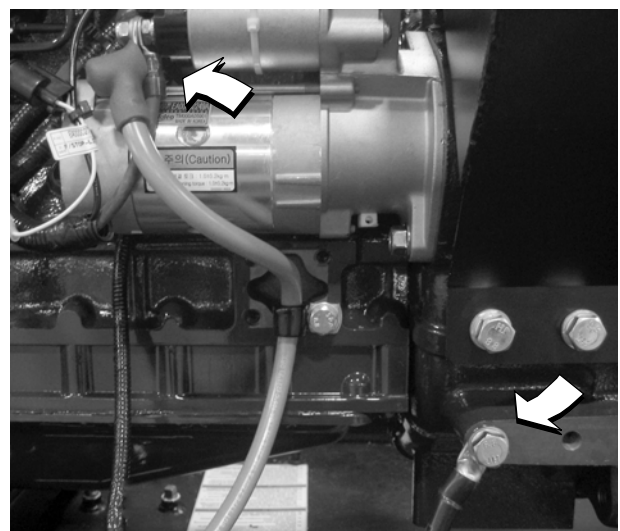

006372

Figure 3-5. Battery Cable Connections

3. Install two screws with nylon washers to secure hold-down clamp to battery tray, or tighten strap over top of battery.
4. Connect red positive battery cable (A) to positive (+) battery terminal.
5. Connect black negative battery cable (B) to negative (-) battery terminal.
6. Thread 10 screws into louvered air intake panel. Alternately tighten screws to 90 **in-lbs** (10 Nm) using a crosswise pattern.

Opening Viewing Window

Proceed as follows to open viewing window:

1. Turn viewing window upward to access control panel.
2. See [Figure 3-6](#). To hold viewing window open, remove rod from clip at back of window and insert into hole in frame (A).

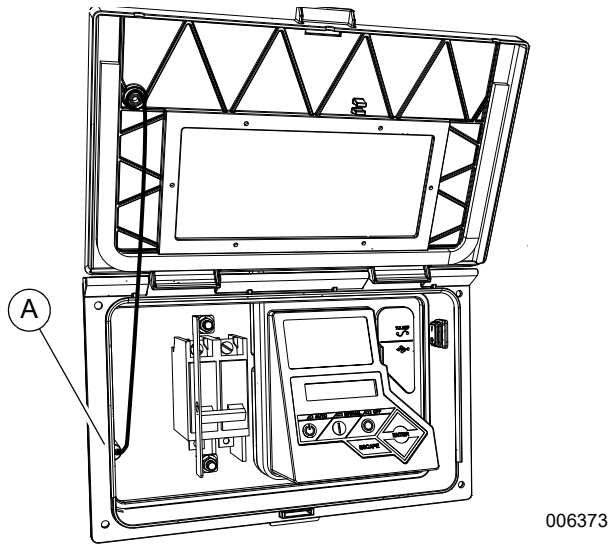

Figure 3-6. Viewing Window

Starting and Running Engine

Proceed as follows to start and run engine:

1. See [Figure 3-7](#). Pull up rubber flap covering fuse holder and verify installation of 7.5 amp fuse (A).

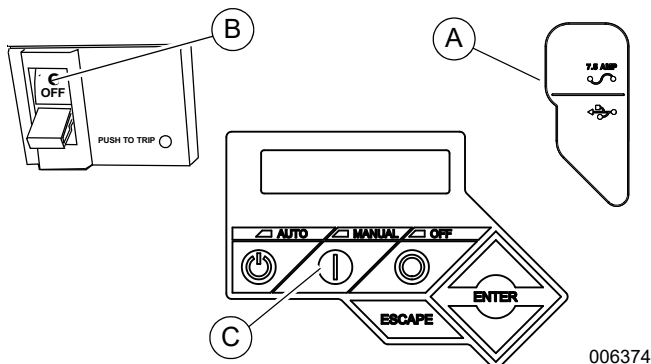

Figure 3-7. Generator Control Panel

2. Set generator MLCB (generator disconnect) to OFF (OPEN) (B).
3. Verify both auxiliary shutdown switches are ON (I).
4. Press MANUAL (C) on control panel to start engine. A blue LED illuminates to verify system is in MANUAL.
5. Allow engine to run until it reaches normal operating temperature.
6. Press OFF on control panel to stop engine. A red LED illuminates to verify system is off.

Testing Auxiliary Shutdown Switch Operation

The generator is equipped with an independent means of shutting down the prime mover (engine) for use in emergency situations. The shutdown mechanism, when activated, requires a mechanical reset.

See [Figure 3-8](#). Generators 15 kW and larger are equipped with two auxiliary shutdown switches. One auxiliary shutdown switch (A) is located on the generator roof above and to the right of the viewing window. The second auxiliary shutdown switch (B) is inside the control panel enclosure.

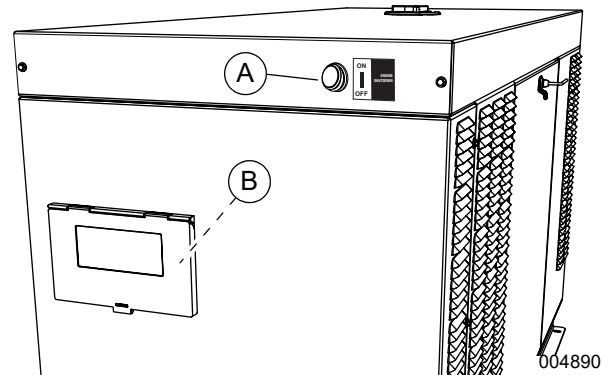

Figure 3-8. Auxiliary Shutdown Switches

Proceed as follows to test auxiliary shutdown switches after installation to verify correct operation:

1. Verify auxiliary shutdown switches are ON (I).
2. Press MANUAL key on control panel keypad to start engine.
3. With engine running, set one auxiliary shutdown switch to OFF (O). Engine should shut down immediately.
 - **If engine stops**, set auxiliary shutdown switch to ON (I), clear alarm on controller, and restart engine to verify generator is operating normally. After verifying normal operation of first auxiliary switch, verify operation of second auxiliary switch.
 - **If engine does not stop**, auxiliary shutdown switch is not functioning correctly. Contact an IASD.

NOTE: Auxiliary shutdown switches are not intended to be a primary means to shut down generator under normal operating conditions. Accidental activation of an auxiliary shutdown switch will prevent generator from operating during a power outage.

Activate Unit

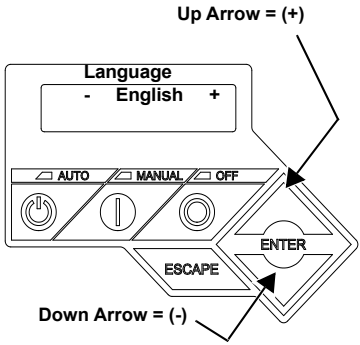
Display Reads		Troubleshooting
	<p>Generator Active is displayed on the LCD screen during initial startup. After displaying firmware and hardware version codes, as well as other system information, Install Wizard is launched and Language screen is displayed.</p> <p>Use UP ARROW or DOWN ARROW to scroll to desired language.</p> <p>Press ENTER.</p>	<p>If wrong language is selected, it may be changed later using the EDIT menu.</p>
<div style="border: 1px solid black; padding: 5px; width: fit-content;"> <p>Activate me (ENT) or ESC to run in manual</p> </div>	<p>Press ENTER.</p>	<p>Press ESCAPE to abort activation sequence. NOT ACTIVATED is displayed and generator will run in MANUAL only. Disconnect and reconnect negative battery cable to restart activation routine. If power is removed after a successful activation, no data is lost, but time and date must be updated.</p>
<div style="border: 1px solid black; padding: 5px; width: fit-content;"> <p>To Activate go to www.activategen.com</p> </div>	<p>Go to www.activategen.com or call 1-888-9ACTIVATE (922-8482, US & CA only) if activation passcode is not available.</p> <p>If activation passcode is available, wait a few seconds for next display.</p>	
<div style="border: 1px solid black; padding: 5px; width: fit-content;"> <p>SN 1234567890 PASS CODE XXXXX</p> </div>	<p>Use UP ARROW or DOWN ARROW to increment or decrement digit to correspond to first number of pass code. Press ENTER.</p> <p>Repeat step to enter remaining digits.</p>	<p>Press ESCAPE to return to preceding digits if a correction becomes necessary.</p> <p>If attempts to enter activation code are unsuccessful, verify number against code given on www.activategen.com. If it is correct, contact 1-888-9ACTIVATE (922-8482, US & CA only).</p>
<div style="border: 1px solid black; padding: 5px; width: fit-content;"> <p>Select Hour (0-23) - 6 +</p> </div>	<ul style="list-style-type: none"> • Use UP ARROW or DOWN ARROW to increment or decrement hour. Press ENTER. • Use UP ARROW or DOWN ARROW to increment or decrement minute. Press ENTER. • Use UP ARROW or DOWN ARROW to select month. Press ENTER. • Use UP ARROW or DOWN ARROW to increment or decrement date. Press ENTER. • Use UP ARROW or DOWN ARROW to increment or decrement year. Press ENTER. 	

<div style="border: 1px solid black; padding: 5px; width: fit-content;"> Quiet Test Mode? Yes No </div>	<p>Use UP ARROW or DOWN ARROW to select either YES or NO.</p> <p>Press ENTER.</p>	<p>Select YES to perform exercise at low speed. Select NO to perform exercise at normal operating speed.</p>
<div style="border: 1px solid black; padding: 5px; width: fit-content;"> Select Hour (0-23) - 1 + </div>	<ul style="list-style-type: none"> • Set Exercise Time. • Use UP ARROW or DOWN ARROW to increment or decrement hour. Press ENTER. • Use UP ARROW or DOWN ARROW to increment or decrement minute. Press ENTER. • Use UP ARROW or DOWN ARROW to scroll to day of week. Press ENTER. 	<p>In AUTO, engine starts and runs once each week at the time and day specified. During exercise cycle, unit runs approximately 12 minutes and then shuts down. Transfer of loads to generator does not occur unless utility power fails.</p>

Operational Checks

NOTE: The following procedures require special tools and skills. Contact an IASD or an authorized service provider to perform these tasks.

Self Test

Controller goes through a system self test upon startup, which checks for utility voltage on DC circuits. This is done to prevent damage if installer mistakenly connects AC utility power sense wires into DC terminal block. If utility voltage is detected, controller displays a warning message and locks out the generator, preventing damage to the controller. Remove power to controller to clear this warning.

Utility voltage must be turned on and present at N1 and N2 terminals inside generator control panel for this test to be performed and pass.

Complete the following before starting:

1. Verify generator is OFF. A red LED on control panel illuminates to verify system is off.
2. Verify generator MLCB (generator disconnect) is OFF (OPEN).
3. Turn off all circuit breakers/electrical loads to be supplied by generator.
4. Verify both auxiliary shutdown switches are ON (I).
5. Check fuel level, coolant level, and engine lubricating oil level. See [Checking Fuel Level and Fill](#), [Inspecting Coolant Level and Hoses](#), and [Checking Lubricating Oil Level](#), respectively.

During initial startup only, generator may exceed normal number of start attempts and experience an “OVER CRANK” fault. This is due to accumulated air in the fuel system during installation. Reset control board by pressing OFF mode button and ENTER button, and restart up to two more times, if necessary. If unit fails to start, contact an IASD for assistance.

Checking Manual Transfer Switch Operation



⚠ DANGER

Electrocution. Do not manually transfer under load. Disconnect transfer switch from all power sources prior to manual transfer. Failure to do so will result in death or serious injury, and equipment damage.

(000132)

See manufacturer's instructions.

Electrical Checks



⚠ DANGER

Electrocution. High voltage is present at transfer switch and terminals. Contact with live terminals will result in death or serious injury.

(000129)

Proceed as follows to complete electrical checks:

1. Verify generator is in OFF mode. A red LED on control panel illuminates to verify system is off.
2. Verify generator MLCB (generator disconnect) is OFF (OPEN).
3. Turn off all circuit breakers/electrical loads to be supplied by generator.
4. Turn on utility power supply to transfer switch using the means provided (such as a utility MLCB).
5. Use an accurate AC voltmeter to verify utility power source voltage across transfer switch terminals N1, N2, and N3 (if three-phase). Normal line-to-line voltage should be equivalent to rated unit voltage.
6. Verify utility power source voltage across terminals N1, N2, and N3 (if three-phase) and transfer switch neutral lug.
7. Turn off utility power supply to transfer switch when utility supply voltage is compatible with transfer switch and load circuit ratings.

8. Press MANUAL on control panel to crank and start engine.
9. Allow engine to warm up for approximately five minutes. Set generator MLCB (generator disconnect) to ON (CLOSED).
10. Connect an accurate AC voltmeter and a frequency meter across transfer switch terminal lugs E1, E2, and E3 (if three-phase).
11. Successively connect AC voltmeter test leads across terminal lugs E1, E2, and E3 (if three-phase) and neutral; then across E2 and neutral. Voltage reading in each case should match utility voltage reading. If system is three-phase, verify generator phase rotation matches utility phase rotation.
12. Set generator MLCB (generator disconnect) to OFF (OPEN).
13. Press generator OFF mode button. The engine will shut down.

IMPORTANT NOTE: Do not proceed unless generator AC voltage and frequency are correct and within stated limits.

Testing Generator Under Load



⚠ DANGER

Electrocution. Do not manually transfer under load. Disconnect transfer switch from all power sources prior to manual transfer. Failure to do so will result in death or serious injury, and equipment damage.

(000132)

Proceed as follows to test generator with electrical loads applied:

1. Verify generator is in OFF mode. A red LED on control panel illuminates to verify system is off.
2. Turn off all breakers/electrical loads to be supplied by generator.
3. Turn off utility power supply to transfer switch, using the means provided (such as a utility MLCB).
4. Manually set transfer switch to STANDBY, i.e., load terminals connected to generator's E1, E2, and E3 (if three-phase) terminals.
5. Press MANUAL on control panel. Engine will crank and start.
6. Allow engine to warm up for a few minutes.
7. Set generator MLCB (generator disconnect) to ON (CLOSED). The transfer switch is now powered by standby generator.
8. Turn on circuit breaker/electrical loads supplied by generator.
9. Connect a calibrated AC voltmeter and a frequency meter across terminal lugs E1, E2, and E3 (if three-phase). Voltage should be approximately unit rated

voltage. Verify with clamp on amp meter to verify unit is not overloaded.

10. Allow generator to run at full rated load for 20–30 minutes. Listen for unusual noises, vibration, or other indications of abnormal operation. Inspect for oil leaks, evidence of overheating, etc.
11. Turn off electrical loads when testing under load is complete.
12. Set generator MLCB (generator disconnect) to OFF (OPEN).
13. Allow engine to run at no-load for 2–5 minutes.
14. Press OFF on control panel to shut down engine. A red LED illuminates to verify system is off.

Checking Automatic Operation

Proceed as follows to check system for correct automatic operation:

1. Verify generator is in OFF mode. A red LED on control panel illuminates to verify system is off.
2. Install front cover of transfer switch.
3. Turn on utility power supply to transfer switch, using the means provided (such as a utility MLCB).

NOTE: Transfer switch will transfer to UTILITY.

4. Set generator MLCB (generator disconnect) to ON (CLOSED).
5. Press AUTO on control panel. The system is now ready for automatic operation.
6. Turn off utility power supply to transfer switch.

With generator ready for automatic operation, engine will crank and start when utility source power is turned off after a 10 second delay (factory default setting). After starting, transfer switch connects load circuits to standby side. Allow system to operate through its entire automatic sequence of operation.

With generator running and loads powered by generator AC output, turn on utility power supply to transfer switch. The system transfers back to utility position and then runs through cool down cycle and shuts down.

Final Instructions

1. Use key to install side access panels.
2. Close viewing window.

NOTE: See [Figure 3-9](#). Obtain viewing window hasp, if not installed. With retaining tab at the bottom, insert square end of viewing window hasp into slot below viewing window. Push on viewing window hasp until it snaps in place. Gently pull on viewing window hasp to verify it will not come free.



Figure 3-9. Install Viewing Window Hasp

3. Install customer supplied padlock into viewing window hasp.

Shutting Generator Down While Under Load or During a Utility Outage

⚠ DANGER

Automatic start-up. Disconnect utility power and render unit inoperable before working on unit. Failure to do so will result in death or serious injury.

(000191)

IMPORTANT NOTE: To avoid equipment damage, follow these steps, in order, during utility outages. Shutdowns may be required during utility outages to perform routine maintenance or to conserve fuel.

To turn generator OFF:

1. Set utility MLCB to OFF (OPEN).
2. Set generator MLCB (generator disconnect) to OFF (OPEN).
3. Allow generator to run for cool-down for approximately one minute.
4. Set generator to OFF at the controller.
5. Remove 7.5A fuse from controller.

To turn generator back ON:

1. Install 7.5A fuse in controller.
2. Verify generator MLCB (generator disconnect) is OFF (OPEN).

3. Set generator to AUTO mode at the controller.
4. Generator will start and run. Allow generator to run and warm up for a few minutes.
5. Set generator MLCB (generator disconnect) to ON (CLOSED).
6. Set utility MLCB to ON (CLOSED).

The system now operates in automatic mode.

This page intentionally left blank.

Section 4: Operation

Control Panel

⚠ DANGER

Automatic start-up. Disconnect utility power and render unit inoperable before working on unit. Failure to do so will result in death or serious injury.

(000191)

NOTE: The control panel is intended for use by qualified service personnel only.

The control panel is located behind the viewing window at the rear of the unit.

IMPORTANT NOTE: With control panel set to AUTO, engine may crank and start at any time without warning. Such automatic starting occurs during the programmed exercise cycle or when utility power source voltage drops below configured level. To prevent possible injury that might occur during sudden starts, always set control panel to OFF and remove the 7.5 amp fuse before working on or around the generator or transfer switch. For added security, place a DO NOT OPERATE tag or placard on both the control panel and transfer switch.

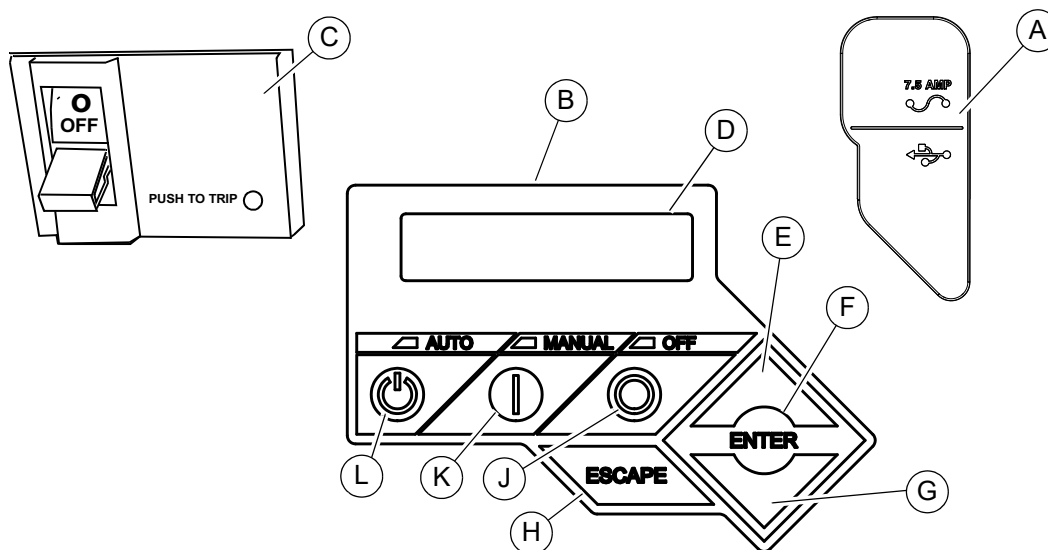

006374

Figure 4-1. Generator Control Panel

A	7.5 amp fuse and USB port cover
B	Control panel
C	MLCB
D	LCD screen
E	UP arrow (+)
F	Enter
G	DOWN arrow (-)
H	Escape
J	OFF (red LED)
K	MANUAL (blue LED)
L	AUTO (green LED)

AUTO/MANUAL/OFF

Feature	Description
AUTO	Activates fully automatic operation. Green LED illuminates to verify system is in AUTO. Transfer to standby power occurs if utility power fails. Functionality of exercise timer is enabled, if set.
MANUAL	Cranks and starts engine. Blue LED illuminates to verify system is in MANUAL. Transfer to standby power occurs if utility power fails. Functionality of exercise timer is disabled.
OFF	Shuts down engine, if running. Red LED illuminates to verify system is in OFF. Transfer to standby power does not occur if utility power fails.

Menu Navigation

See [Figure 4-2](#).

Feature	Description
System Menus	
HOME Screen	System returns to HOME screen if control panel is not used for five minutes. Screen normally displays a Status message, such as Ready to Run (AUTO) or Switched to OFF (OFF), and total Hours of Protection. If an active alarm/warning condition occurs, associated Alarm/Warning message is displayed. To clear Alarm/Warning message, press OFF on control panel followed by ENTER. In event of multiple Alarms/Warnings, next message is then displayed. The highest priority alarm is always displayed first.
MAIN MENU	Allows operator to navigate software using UP arrow, DOWN arrow, ENTER, and ESCAPE. MAIN MENU can be accessed from any sub menu by consecutively pressing ESCAPE. Each time ESCAPE is pressed, the preceding menu is displayed. The MAIN MENU is reached when System, Date/Time, Battery, and Sub Menus are displayed.
Navigation	
ESCAPE	Used to abort a routine or return to preceding menu.
ENTER	Used to make a selection or save an entry.
UP ARROW DOWN ARROW	Used to move forward or backward from menu to menu or to scroll forward or backward (increment or decrement) through available selections.
NOTE: Pressing control panel illuminates backlight for 30 seconds. The backlight also illuminates for 30 seconds whenever an active Alarm/Warning message is displayed.	

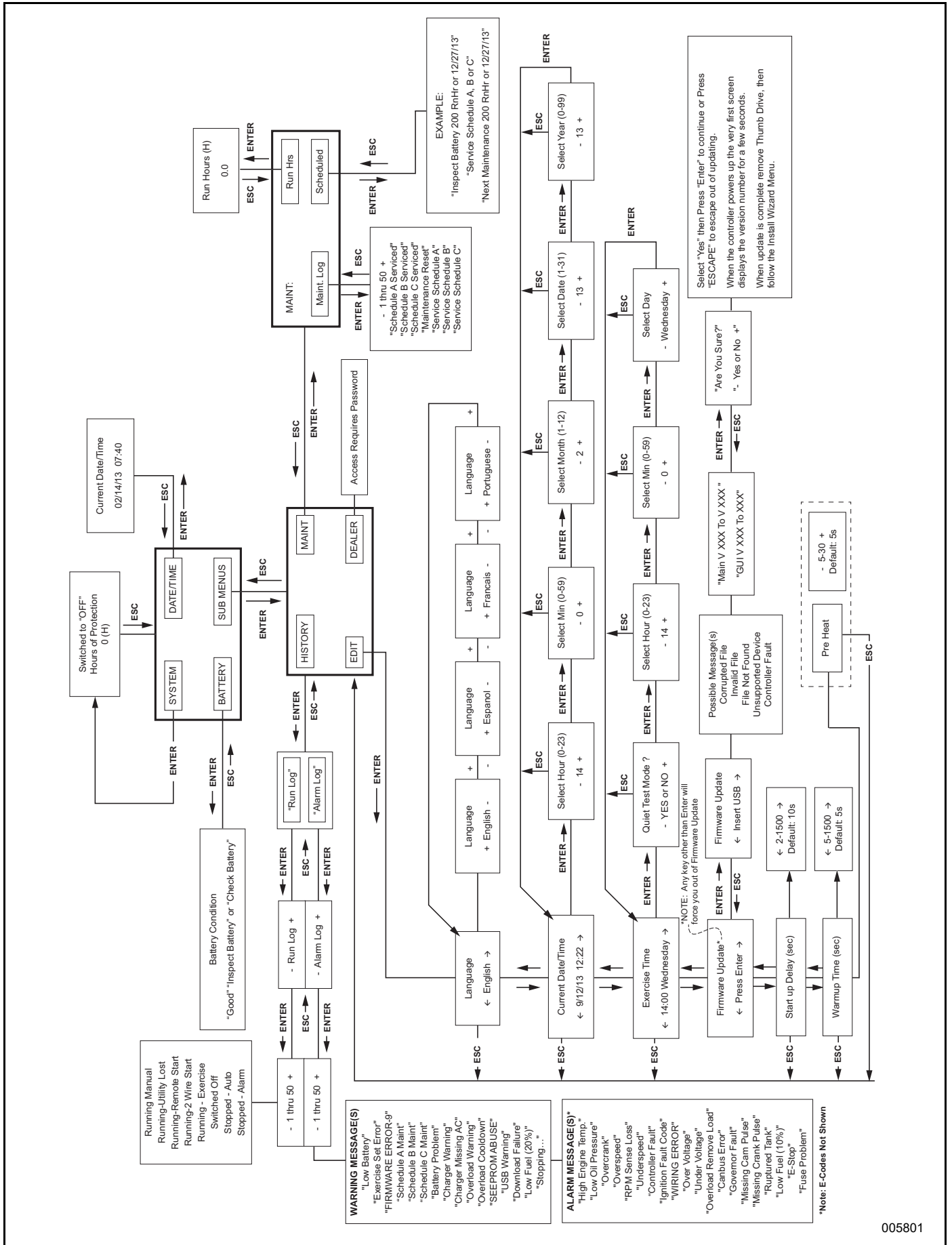

005801

Figure 4-2. Navigation Menu

Alarm/Warning Conditions

The owner/operator is alerted to Alarm and/or Warning conditions via the control panel LCD. All Alarm conditions cause generator to shut down. Warning messages alert operator to conditions that do not disable unit or require immediate correction.

The possible Alarm/Warning messages are listed below.

Alarm Messages	Warning Messages
<ul style="list-style-type: none"> • High Engine Temperature • Low Coolant Level • Low Oil Pressure • Overcrank • Overspeed • RPM Sense Loss • Underspeed • Controller Fault • Ignition Fault Code • WIRING ERROR • Over Voltage • Under Voltage • Overload Remove Load • Canbus Error • Governor Fault • Missing Cam Pulse • Missing Crank Pulse • Ruptured Tank • Low Fuel (10%) • E-Stop • Fuse Problem • Auxiliary Shutdown 	<ul style="list-style-type: none"> • Low Battery • Exercise Set Error • FIRMWARE ERROR-9 • Schedule A Maintenance • Schedule B Maintenance • Schedule C Maintenance • Battery Problem • Charger Warning • Charger Missing AC • Overload Warning • Overload Cooldown • SEEPROM ABUSE • USB Warning • Download Failure • Low Fuel (20%) • Stopping...

NOTE: Unless correctly trained to correct and clear Alarm/Warning conditions, contact an IASD or trained service technician.

Changing Time and Date

To change time and date after activation, see Navigation Menu in [Figure 4-2](#). If power is lost (battery is disconnected/reconnected, control panel fuse is removed/installed, etc.), display automatically prompts user for Time and Date. All other information is retained in memory.

Programmable Timers

Dealer Programmable

Exercise Timer

A programmable exercise timer is provided. In AUTO, engine starts and runs once each week at time and day specified. During exercise cycle, unit runs approximately 12 minutes and then shuts down. Transfer of loads to generator does not occur unless utility power fails.

NOTE: A dealer password is required to change the exercise timer.

User Programmable

Startup Delay Timer

A programmable line interrupt delay (or startup delay) timer is provided. When utility voltage fails (falls below 65% of nominal), the startup delay timer is started. If voltage rises above Utility Volts Low threshold, timer is reset. If utility voltage remains below threshold during the duration of the timer, unit cranks and starts.

NOTE: Factory default setting is five seconds, but is adjustable from 2 to 1500 seconds.

Warm-Up Delay Timer

A programmable warm-up delay timer is provided. As soon as generator starts, warm-up timer starts. When warm-up timer expires, control transfers load to generator (through transfer switch) if utility voltage is less than 80% of nominal. If utility voltage is greater than threshold at expiration of warm-up time, load is **not** transferred to the generator and a cool-down period begins. At the end of the cool-down period, generator stops.

NOTE: Factory default setting is five seconds, but is adjustable from 5 to 1500 seconds.

USB Port for Firmware Updates

A USB port is located beneath the rubber flap on the control panel, and is provided for firmware updates. Firmware updates must be performed by an IASD.

IMPORTANT NOTE: The USB port is intended for use with a USB thumb drive only. USB port is not intended for charging devices such as phones or laptops. Do not connect any consumer electronics to USB port.

Battery Charger

NOTE: Battery charger is integrated into control panel module.

The battery charger ensures:

- Output is continually optimized to promote maximum battery life.
- Charging levels are safe.

NOTE: A warning message is displayed on the LCD when battery requires service.

Transfer Switch Automatic Operation

In AUTO, generator starts automatically when utility source voltage drops below preset level. Loads are transferred to standby power source once unit starts.

Proceed as follows to select automatic operation:

1. Verify transfer switch main contacts are set to UTILITY (loads connected to utility power source).
2. Verify normal utility power source voltage is available to transfer switch terminal lugs N1, N2, and N3 (if three-phase).
3. Set generator MLCB (generator disconnect) to ON (CLOSED).
4. Press AUTO on control panel. A green LED illuminates to verify system is in AUTO.

Automatic Sequence of Operation

Utility Failure

If control panel is set to AUTO when utility power fails (falls below 65% of nominal, dealer programmable), a **ten** second startup delay timer is started (user programmable). If utility power is still absent when time expires, engine cranks and starts.

Once started, a **five** second engine warm-up delay timer starts (user programmable). When time has elapsed, load is transferred to generator. If utility power is restored (above 80% of nominal, dealer programmable) between time engine is first started and expiration of warm-up time, controller completes start cycle and then runs through its normal cool-down cycle (while load remains on utility source throughout episode).

Cranking

The cyclic cranking is controlled as follows:

Fifteen (15) seconds crank, seven (7) seconds rest, seven (7) seconds crank, seven (7) seconds rest; this sequence is repeated for a total of six (6) crank cycles.

Load Transfer

With generator running, transfer of load is dependent upon operating mode as follows:

AUTO	<ul style="list-style-type: none"> • Starts and runs if utility power fails (falls below 65% of nominal) for five consecutive seconds (adjustable). • Starts a five second (adjustable) engine warm-up timer. • Does not execute transfer if utility power returns before expiration of warm-up timer (but finishes warm-up and cool-down cycles). • Transfers back to utility once utility power returns (above 80% of nominal) for 15 consecutive seconds. • Only shuts down if OFF is pressed or an alarm shutdown occurs. • Once utility power returns, starts a cool-down cycle before it shuts down. <p>NOTE: Cool-down cycle is five minutes if turbocharger equipped, one minute if naturally aspirated.</p>
	EXERCISE
	<ul style="list-style-type: none"> • Only works in AUTO. • Does not exercise if generator is already running in AUTO. • During exercise cycle, transfers only if utility power fails for ten consecutive seconds.
MANUAL	<ul style="list-style-type: none"> • Engine cranks and runs even if utility power is present, but does not transfer to generator. • Transfers to generator if utility fails (falls below 65% of nominal) for ten consecutive seconds. • Transfers back to utility when utility returns for 15 consecutive seconds. The engine continues to run until AUTO or OFF key is pressed.

Transfer Switch Manual Operation



⚠ DANGER

Electrocution. Do not manually transfer under load. Disconnect transfer switch from all power sources prior to manual transfer. Failure to do so will result in death or serious injury, and equipment damage.

(000132)

Prior to automatic operation, manually exercise transfer switch to verify there is no binding or interference with correct operation of the mechanism. Manual operation of transfer switch is required if automatic operation fails.

IMPORTANT NOTE: Always use applicable transfer switch owner's manual for actual manual transfer switch operation instructions. The information presented here describes a typical V-style transfer switch, which is not used for three phase applications.

Transfer to Generator Power

Proceed as follows to manually transfer to standby power and start generator when utility power fails:

1. Press OFF on control panel. A red LED illuminates to verify system is OFF.
2. Set generator MLCB (generator disconnect) to OFF (OPEN).
3. Turn off utility power supply to transfer switch using the means provided (such as a utility MLCB).
4. See [Figure 4-3](#). Use manual transfer handle (A) inside transfer switch to set main contacts to STANDBY (loads connected to standby power source) (C).

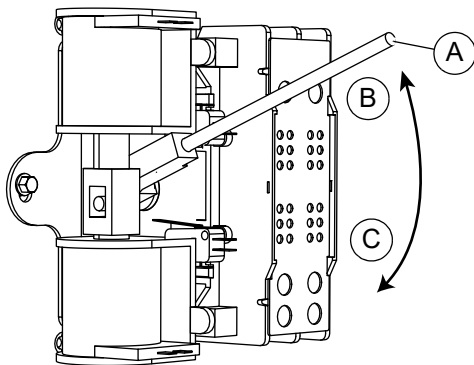

Figure 4-3. Manual Transfer Switch Operation (Typical)

5. Press MANUAL on control panel. Engine cranks and starts.
6. Allow engine to run for two minutes to bring it up to normal operating temperature.
7. Set generator MLCB (generator disconnect) to ON (CLOSED).

NOTE: V-style transfer switch not used for three-phase applications.

Transfer Back to Utility Power

Proceed as follows to manually transfer back to utility power and shut down generator when utility power is restored:

NOTE: Verify utility voltage has returned and is at the correct value.

1. Set generator MLCB (generator disconnect) to OFF (OPEN).
2. Allow engine to run for two minutes at no-load to bring it up to normal operating temperature.
3. Press OFF on control panel to shut down engine.
4. Verify utility power supply to transfer switch is turned off.
5. Use manual transfer handle inside transfer switch to set main contacts to UTILITY (B) (loads connected to utility power source).
6. Turn on utility power supply to transfer switch using the means provided (such as a utility MLCB).
7. Press AUTO on control panel. A green LED illuminates to verify system is in AUTO.

Section 5: Maintenance

Component Locations

The side of enclosure with the viewing window is identified as the rear of the generator. The right and left sides are identified by standing at the rear and looking towards the front of the unit.

NOTE: The 2.2L engine is depicted in the artwork used in this manual. The location and appearance of some components may vary between engine models.

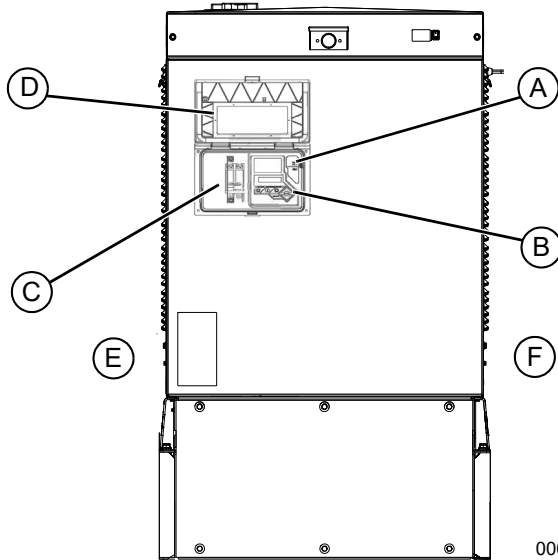

A	7.5 Amp fuse and USB port
B	Control panel and LCD
C	Main line circuit breaker (MLCB)
D	Viewing window
E	Left side
F	Right side

Figure 5-1. Rear View

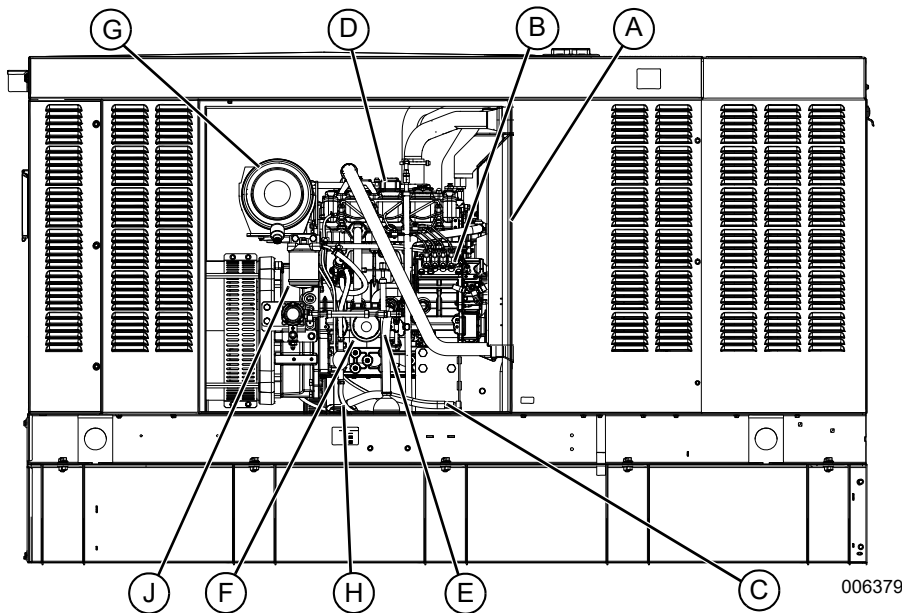

A	V-belt (not shown)
B	Electronic governor (2.2L engines)
C	Oil drain hose
D	Oil fill cap
E	Oil level dipstick
F	Oil filter
G	Air filter
H	Fuel supply/return hoses
J	Fuel filter/air bleed

Figure 5-2. Right Side View

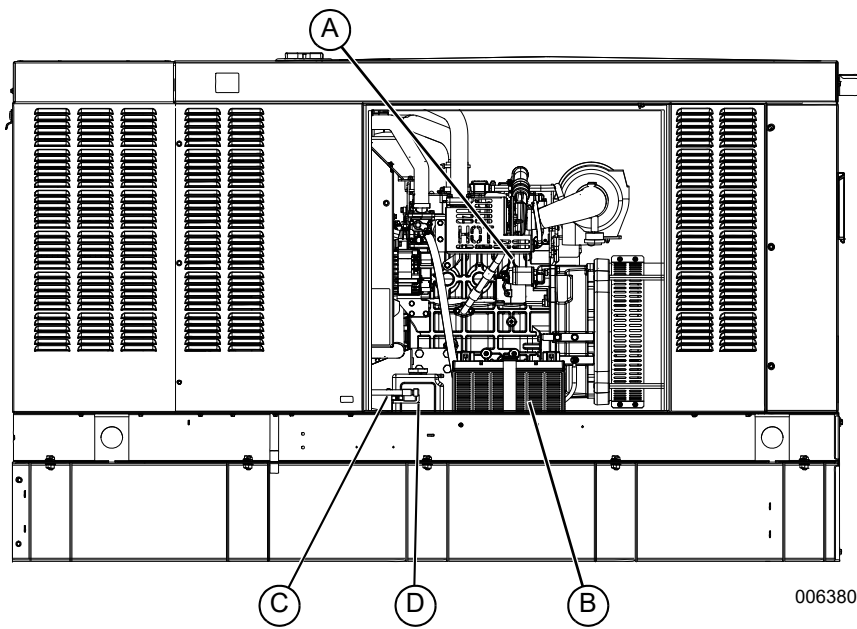

A	Governor linkage (2.5L engines; not shown)
B	Battery
C	Coolant drain hose
D	Coolant overflow reservoir

Figure 5-3. Left Side View

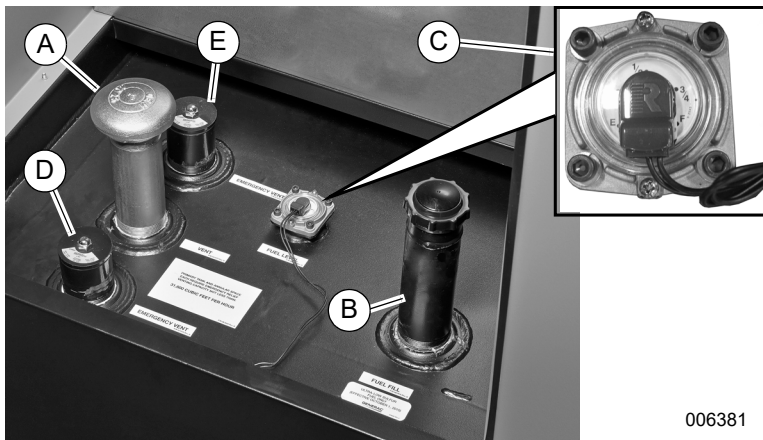

A	Fuel tank (primary vent)
B	Fuel filler spout
C	Fuel level gauge
D	Emergency vent (secondary tank)
E	Emergency vent (primary tank)

006381

Figure 5-4. Front View

Access Panels

Access panels are located at both the front and sides of the enclosure.

Removal

Proceed as follows to remove access panels:

1. See [Figure 5-5](#). Insert key (B) into latch (A) and turn counterclockwise one-half turn.

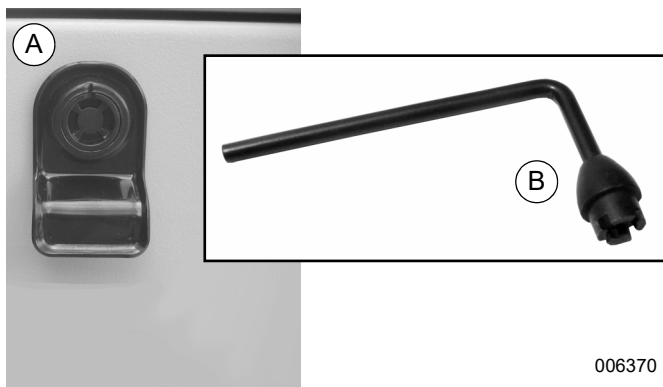

Figure 5-5. Access Panel Key

2. Raise panel using thumb latch.

Installation

Proceed as follows to install access panels:

1. Lower panel into position using thumb latch.
2. Insert key into latch and turn clockwise one-half turn.

Service Maintenance Intervals

WARNING

Equipment damage. Only qualified service personnel may install, operate, and maintain this equipment. Failure to follow proper installation requirements could result in death, serious injury, and equipment or property damage.

(000182a)

NOTE: Generac recommends using genuine Generac OEM parts to avoid problems that could affect warranty coverage.

It is important to perform all maintenance at interval specified in the [Service Maintenance Schedule](#). This verifies safe and correct operation, as well as compliance with applicable emissions standards. Critical emissions maintenance must be performed for emissions warranty to remain valid. Service and repairs may be performed by any qualified service technician or repair shop.

Service Maintenance Schedule

Observe maintenance tasks and intervals shown in the table below.

Service	30 Hours Engine Break In	Daily If Running Continuously	Schedule A Every Year or 125 Hours	Schedule B Every 2 Years or 250 Hours	Schedule C Every 1000 Hours
Check fuel level and fill		•	•	•	•
Drain fuel filter		•	•	•	•
Inspect fuel lines and hoses		•	•	•	•
Check coolant level		•	•	•	•
Inspect coolant hoses		•	•	•	•
Inspect radiator for clogging		•	•	•	•
Check lubricating oil level		•	•	•	•
Check battery condition/fluid level			•	•	•
Inspect/adjust v-belt tension			•	•	•
Replace air filter element			•	•	•
Drain breather canister and replace filter			•	•	•
Lubricate governor rod linkage			•	•	•
Replace lubricating oil and oil filter	•			•	•
Replace fuel filter element				•	•
Drain/flush coolant system				•	•
Inspect fuel tank					•
Inspect/adjust fuel injection valve pressure					•
Adjust intake/exhaust valve clearance					•
Inspect/adjust fuel injection pump timing					•
Tighten critical fasteners					•

NOTE: If unit reaches a Schedule A or Schedule B maintenance interval with 900 to 999 total hours, have an IASD perform Schedule C maintenance tasks as well (and reset A-B-C/Year maintenance schedule counter).

Remove From Service

To verify safety, follow steps below prior to inspection, maintenance, or service.

IMPORTANT NOTE: If currently experiencing a utility outage, see subsection [Removal From Service During Utility Outages](#) for special instructions.

1. Open viewing window. See [Opening Viewing Window](#).

2. See [Figure 5-6](#). Set generator MLCB (generator disconnect) to OFF (OPEN) (A).
3. Press OFF (B) on control panel. A red LED illuminates to verify system is OFF.
4. Remove T1 fuse from transfer switch.
5. Pull up rubber flap (C) covering fuse holder and remove 7.5 amp fuse.
6. Place a DO NOT OPERATE tag or placard on both the control panel and transfer switch.
7. If unit has been running, wait five minutes for engine to cool.

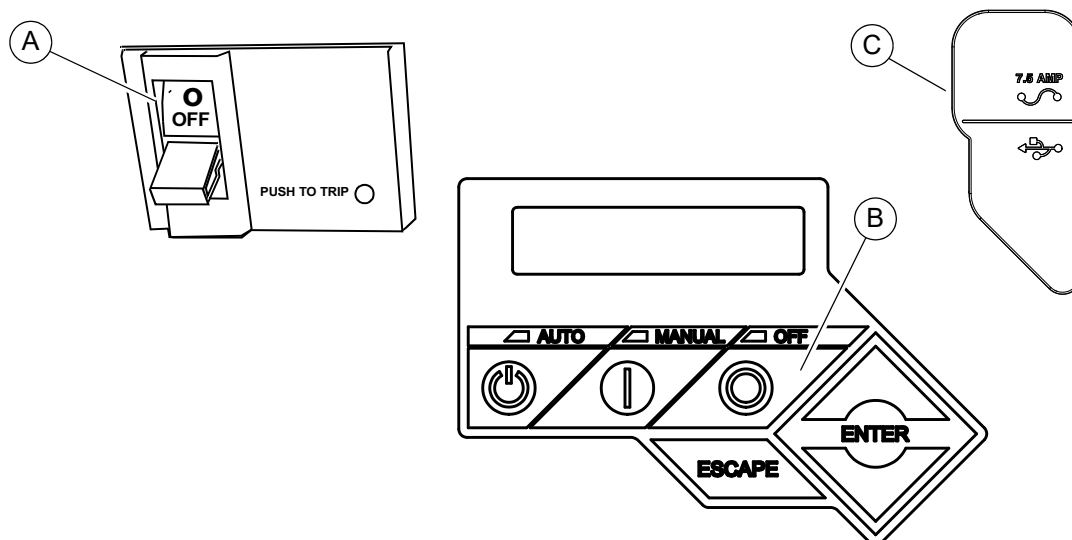

006374

Figure 5-6. Generator Control Panel

30 Hour Break-In

Perform the following task:

- Replace Lubricating Oil and Oil Filter

NOTE: See [Replacing Lubricating Oil and Oil Filter](#) under Schedule B Maintenance.

Daily Maintenance (If Running Continuously)

Perform the following tasks:

- Check fuel level and fill
- Drain fuel filter
- Inspect fuel lines and hoses
- Check coolant level
- Inspect coolant hoses
- Inspect radiator for clogging
- Check lubricating oil level

NOTE: See [Preliminary Instructions](#) through [Checking Lubricating Oil Level](#) under [Schedule A Maintenance](#).

Schedule A Maintenance

NOTE: Perform Schedule A maintenance once each year or after 125 hours of service, whichever comes first.

Preliminary Instructions

1. See [Remove From Service](#).
2. Remove access panels at front and both sides of enclosure. See [Access Panels](#).
3. Remove negative battery cable (black) from negative (-) battery terminal.

NOTE: For general location of components, see [Component Locations](#).

Checking Fuel Level and Fill

Proceed as follows to check fuel level and fill fuel tank:

1. See [Figure 5-7](#). Inspect fuel gauge to note level of fuel in tank.

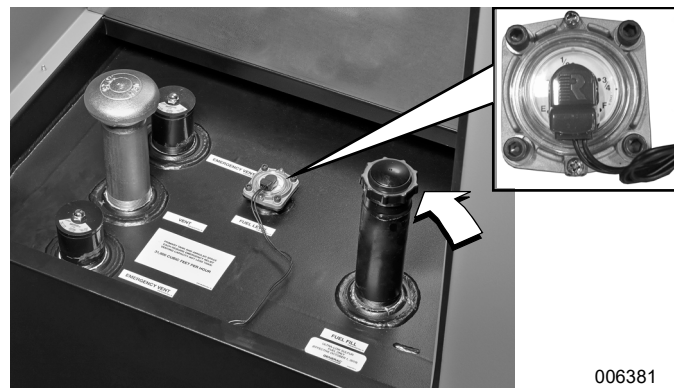

006381

Figure 5-7. Check Fuel Level Gauge and Fill

2. Remove fuel fill cap from filler pipe.
3. Add fuel until needle on fuel gauge approaches the F(ull) mark.
4. Install fuel fill cap onto filler pipe.

Draining Fuel Filter and Inspect Fuel Lines/Hoses

Proceed as follows to drain fuel filter and inspect fuel lines/hoses:

1. See [Figure 5-8](#). Place a shop rag beneath fuel filter (A) to catch water or fuel drips.



Figure 5-8. Drain Fuel Filter (2.5L Engine)

2. Turn fuel filter counterclockwise to remove from filter adapter.
3. Install **new** fuel filter by hand until gasket just contacts filter adapter. Tighten fuel filter an additional three-quarters to one full turn.

NOTE: Dispose of used filter in accordance with national, state, or local laws.

4. Inspect fuel filter and fuel lines/hoses for leaks. Tighten filter, fittings, and hose clamps if necessary.
5. Inspect fuel hoses for nicks, cuts, tears, or general deterioration. Replace as necessary.

Inspecting Coolant Level and Hoses



WARNING

Risk of burns. Allow engine to cool before draining oil or coolant. Failure to do so could result in death or serious injury.

(000139)

NOTE: On 2.5L models, remove ten screws to release louvered air discharge panel on left side of enclosure.

Proceed as follows to inspect coolant level and hoses:

1. See [Figure 5-9](#). Verify coolant level is between HOT and COLD marks on overflow reservoir (B). Coolant expands when hot; coolant level may be higher than HOT mark. Do not add coolant higher than HOT mark.
2. Remove fill cap from overflow reservoir and add coolant if coolant level is below COLD mark. See [Draining/Flushing Coolant System](#).

3. Inspect coolant hoses (A) for leaks. Tighten hose clamps, if necessary.
4. Inspect hoses for nicks, cuts, tears, or general deterioration. Replace as necessary.

NOTE: On 2.5L models, install louvered air discharge panel. Alternately tighten ten screws to 90 **in-lbs** (10 Nm) using a crosswise pattern.

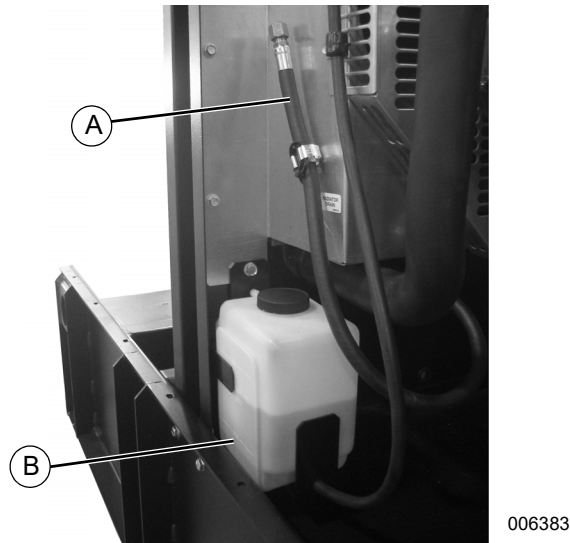

Figure 5-9. Coolant Overflow Reservoir and Drain Hose (3.3L Engine)

Checking Radiator for Clogging

Direct a flashlight beam through openings in fan guard to inspect radiator fins. Inspect for debris, accumulations of dirt, or other deposits. Proceed as follows to clean radiator, if necessary:

1. On right side of enclosure, loosen two clamps at each end of turbocharger exhaust outlet pipe. Remove pipe, clamps, and rubber couplings from engine.
2. Remove four screws with nylon washers to release fan guard from radiator shroud.
3. On left side of enclosure, loosen two clamps at each end of air intake pipe. Remove pipe, clamps, and rubber couplings from engine.
4. Remove coolant hoses from holding clamps.
5. Remove four screws with nylon washers to release fan guard from radiator shroud.
6. Carefully remove any debris from radiator fins. Use warm soapy water and a soft bristled brush to remove dirt and other deposits, if necessary.
7. On left side of enclosure, install four screws with nylon washers to fasten fan guard to radiator shroud.
8. Install coolant hoses into holding clamps.
9. Install clamps and rubber couplings onto each end of air intake pipe. Install pipe to air heater and radiator shroud. Tighten clamps.

10. On right side of enclosure, install four screws with nylon washers to fasten fan guard to radiator shroud.
11. Install clamps and rubber couplings onto each end of turbocharger exhaust outlet pipe. Install pipe to turbocharger outlet and radiator shroud. Tighten clamps.

Checking Lubricating Oil Level

Proceed as follows to check lubricating oil level:

1. See [Figure 5-10](#). Remove dipstick (A) and wipe with a clean cloth.

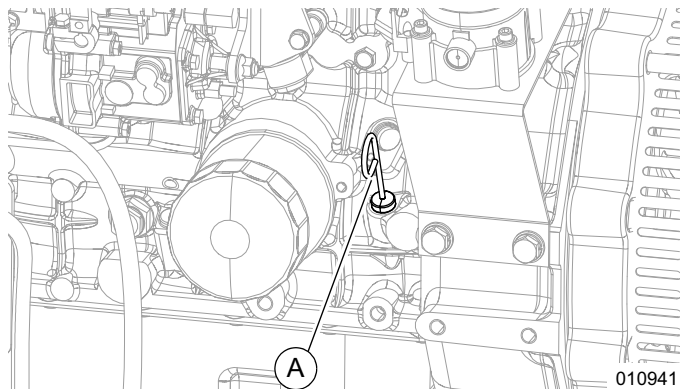

Figure 5-10. Oil Level Dipstick (3.3L Engine)

2. Completely insert oil dipstick and then remove it.
3. Verify oil level is at or near H(igh) mark.

NOTE: Each hash mark or line below H(igh) mark represents one liter. Add oil whenever oil level is one liter or more below H(igh) mark.

4. If necessary, remove oil fill cap and slowly add oil until level is at H(igh) mark. **DO NOT OVERFILL.**
5. Install oil dipstick and oil fill cap.
6. Inspect oil drain hose for leaks, nicks, cuts, tears, or general deterioration. Replace as necessary.

Checking Battery Condition/Fluid Level

Checking Condition and Cleaning

NOTE: On 2.5L models, remove ten screws to release louvered air intake panel on left side of enclosure.

1. Verify top of battery is clean and dry. Dirt and electrolyte on top of battery can cause battery to self-discharge. Clean battery top with a solution of baking soda (sodium bicarbonate) and water (5 teaspoons baking soda per quart or liter of water). When solution stops bubbling, rinse off battery with clean water.
2. Clean battery cable clamps and battery terminals using a wire brush or sandpaper to remove any oxidation.

3. Inspect battery screws, clamps, and cables for breakage, loose connections, and corrosion. Tighten and clean as necessary.
4. Inspect battery posts for melting or damage caused by over tightening.
5. Inspect battery for discoloration, raised top, or a warped or distorted case, which might indicate battery has been frozen, overheated, or overcharged.
6. Inspect battery case for cracks or leaks.
7. Check battery fluid level of unsealed batteries. See [Checking Fluid Level](#).
8. Check battery state of charge. See [Checking State of Charge](#).
9. Replace battery if necessary. See [Battery Replacement](#).

NOTE: On 2.5L models, start ten screws to install louvered air intake panel. Alternately tighten screws to 90 in-lbs (10 Nm) using a crosswise pattern.

Checking Fluid Level

Check fluid level of unsealed batteries. If necessary, fill with distilled water only. DO NOT use tap water.

Checking State of Charge

Check state of charge using a digital multimeter. Charge and test if state of charge is below manufacturer's recommendations. Replace battery if necessary.

Battery Replacement

Removal

WARNING

Accidental Start-up. Disconnect the negative battery cable, then the positive battery cable when working on unit. Failure to do so could result in death or serious injury.

(000130)

Proceed as follows to remove battery:

1. See **Figure 5-11**. Remove negative battery cable (black) (B) from negative (-) battery terminal.

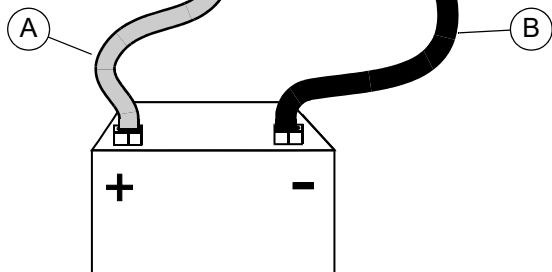
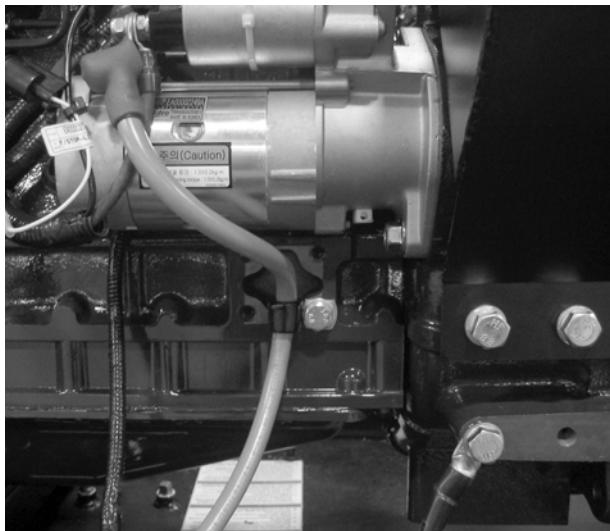

006385

Figure 5-11. Battery Cable Connections

2. Remove positive battery cable (red) (A) from positive (+) battery terminal.
3. See **Figure 5-12**. Install rubber protective cover (C) over positive (+) battery terminal.

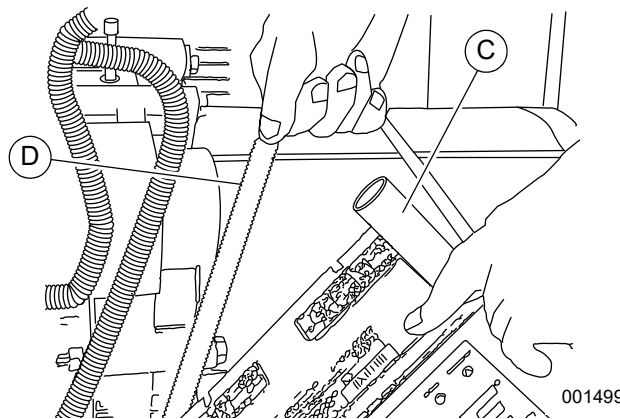

001499

Figure 5-12. Remove/Install Battery

4. Loosen two screws with nylon washers to release battery hold-down clamp from battery tray, or loosen strap and position away from tray.
5. Grasp battery strap (D) next to positive (+) battery terminal, and lift battery.
6. When battery tilts sideways, remove from opening.
7. Remove rubber protective cover from positive (+) battery terminal.

Installation

WARNING



Explosion. Batteries emit explosive gases. Always connect positive battery cable first to avoid spark. Failure to do so could result in death or serious injury.

(000133)

CAUTION



Equipment damage. Do not make battery connections in reverse. Doing so will result in equipment damage.

(000167a)

NOTE: Always connect positive battery cable first. If positive battery cable should contact ground with negative battery cable installed, resulting sparks may cause a battery explosion.

Proceed as follows to install battery:

1. See **Figure 5-12**. Install rubber protective cover (C) over positive (+) battery terminal.
2. Grasp battery strap (D) next to positive (+) battery terminal, and lift battery.
3. When battery tilts sideways, insert into opening.
4. Return battery to horizontal position while sliding it onto battery tray.
5. Tighten two screws with nylon washers to secure hold-down clamp to battery tray, or tighten strap over top of battery.

6. Remove rubber protective cover from positive (+) battery terminal.
7. Install battery positive battery cable to positive (+) battery terminal.
8. Install battery negative battery cable to negative (-) battery terminal.

Inspecting and Adjusting V-Belt

Check V-belt deflection. Too little belt deflection accelerates belt wear, while too much deflection causes pulley to idle, overheats engine, and creates a no-load condition. Proceed as follows to check and adjust belt deflection:

1. On right side of enclosure, loosen two clamps at each end of turbocharger exhaust outlet pipe. Remove pipe, clamps, and rubber couplings from engine.
2. Remove four screws with nylon washers to release fan guard from radiator shroud.
3. Inspect belt for cracks, fraying, excessive wear, or other damage.
4. Verify belt is free of grease and oil. Replace belt if contaminated.

NOTE: Use a solution of soap and warm water to clean pulleys, if necessary. Avoid use of solvents, but if used, always follow by a soap and water wash.

5. See [Figure 5-13](#). Using a suitable belt deflection gauge (A), apply 22 lbs (10 kg) force midway between the crankshaft (B) and alternator pulleys (C).
6. Take note of gauge reading. If belt deflection is not within specification, see [Adjusting V-Belt Tension](#).

Belt Condition	Deflection
New	0.31–0.47 in (8–12 mm)
Used	0.39–0.59 in (10–15 mm)

7. Install four screws with nylon washers to fasten fan guard to radiator shroud.
8. Install clamps and rubber couplings onto each end of turbocharger exhaust outlet pipe. Install pipe to turbocharger outlet and radiator shroud. Tighten clamps.

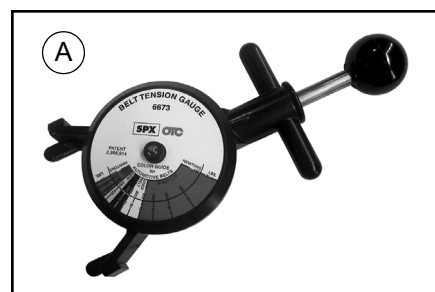
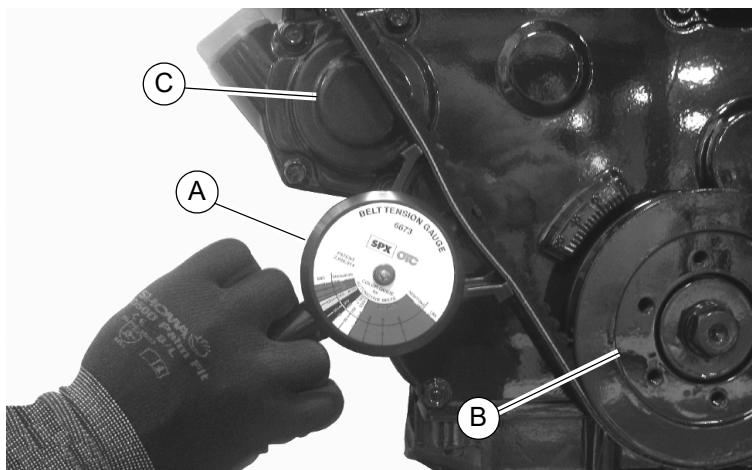

Figure 5-13. Check V-Belt Deflection

006386

Adjusting V-Belt Tension

Proceed as follows to adjust v-belt tension:

1. Loosen tension adjuster screw (top). Loosen hex nut on pivot screw (bottom). Turn alternator outward to reduce belt deflection, turn inward to increase belt deflection.
2. Tighten tension adjuster screw (top) to 17–22 ft-lbs (23–30 Nm). Tighten hex nut on pivot screw (bottom) to 33–43 ft-lbs (45–58 Nm).
3. Verify belt deflection and repeat steps as necessary.

Replacing Air Filter Element—2.5L Engine

Proceed as follows to replace air filter element in 2.5L engines:

1. See [Figure 5-14](#). Remove wing nut (A), flat washer (B), and lock washer (C) from threaded rod to release air cleaner cover (D).

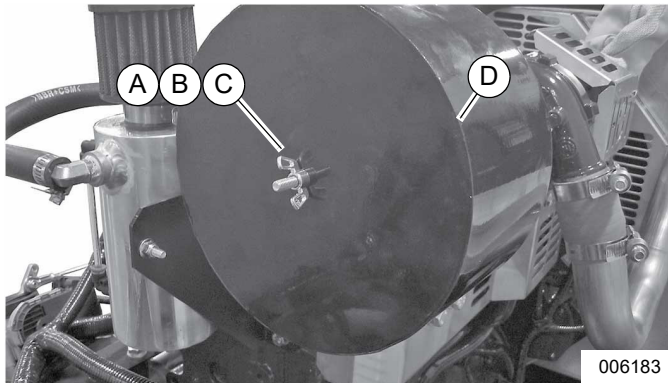

Figure 5-14. Remove Air Cleaner Cover—2.5L Engine

2. See [Figure 5-15](#). Remove air filter element (E) and discard.

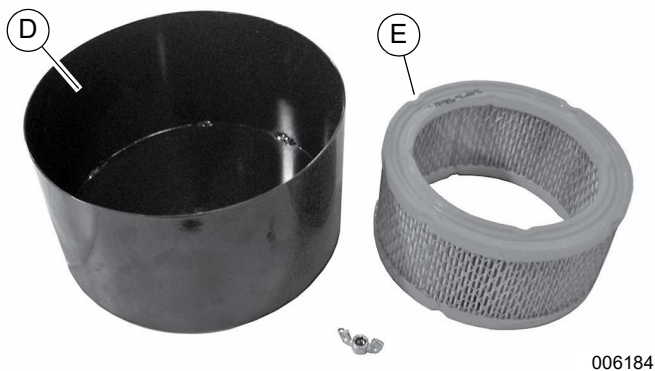

Figure 5-15. Remove Air Filter Element—2.5L Engine

3. Thoroughly clean air cleaner cover (D) of any dust, dirt, or debris.
4. Place **new** air filter element against adapter flange.

NOTE: The air filter element is not directional.

5. Install air cleaner cover over threaded rod, followed by flat washer, lock washer, and wing nut. Tighten wing nut until snug.

Replacing Air Filter Element—2.2L Engine

Proceed as follows to replace air filter element in 2.2L engines:

NOTE: The 2.2L engine is equipped with an alternate-style air cleaner.

1. See [Figure 5-16](#). Release three buckle clasps from end cap (A) of air cleaner canister (B). Remove end cap.

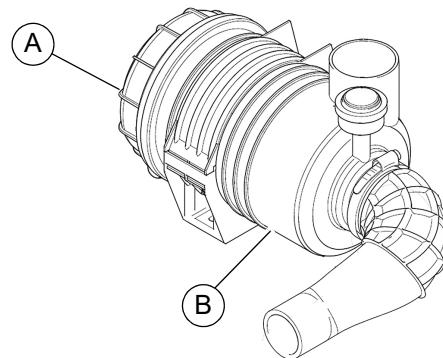

006185

Figure 5-16. Disassemble Air Cleaner—2.2L Engine

2. See [Figure 5-17](#). Remove air filter element (C) and discard.

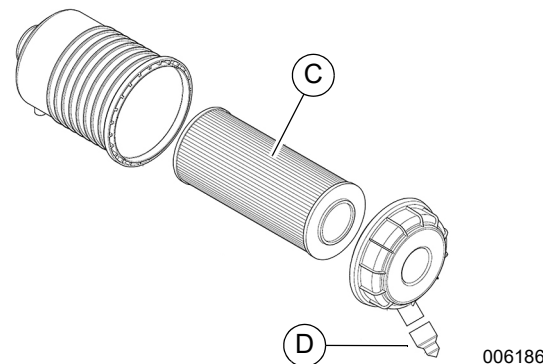

006186

Figure 5-17. Remove Air Filter Element—2.2L Engine

3. Thoroughly clean air cleaner canister, end cap, and breather (D) of any dust, dirt, or debris.
4. Place **new** air filter element inside canister.

NOTE: The air filter element is not directional.

5. Install end cap on air cleaner canister and buckle three clasps.

Replacing Air Filter Element—3.3L Engine

Proceed as follows to replace air filter element in 3.3L engines:

NOTE: 3.3L engine air filter element is not compatible with 2.5/2.2L engines.

1. See [Figure 5-18](#). Use flathead screwdriver to hold slotted bolt (A) while loosening square nut to expand air filter element clamp (B).

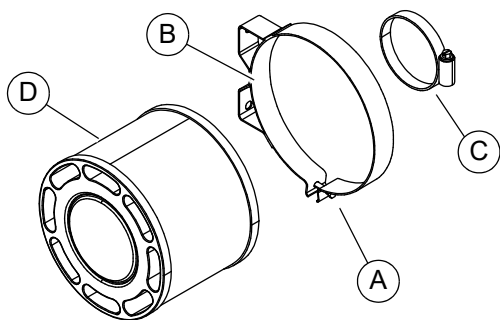

009255

Figure 5-18. Remove Air Filter Element—3.3L Engine

2. Loosen hose clamp (C) around air filter element base and remove air filter element (D) from air intake pipe. Discard old air filter element.
3. Thoroughly clean air intake pipe and air filter element clamp of any dust, dirt, or debris.
4. Place **new** air filter element through air filter element clamp and on the air intake pipe.
5. Securely fasten hose clamp around new air filter element.
6. With air filter element correctly positioned in air filter element clamp, use flathead screwdriver to hold slotted bolt in place while tightening square nut until clamp is secure.

Lubricating Governor Rod Linkage (2.5L and 3.3L Engines)

Proceed as follows to lubricate governor rod linkage in 2.5L and 3.3L engines:

1. See [Figure 5-19](#). Lubricate both ends of rod (A) with a silicone spray.

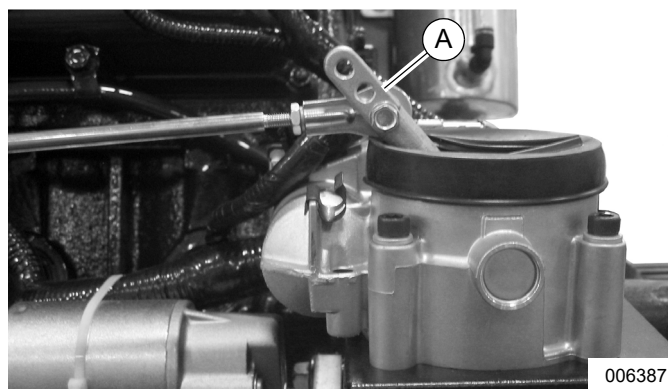

006387

Figure 5-19. Lubricate Governor Rod Ends (2.5L and 3.3L Engines)

2. Verify rod moves freely without binding.

Final Instructions

1. Install negative battery cable (black) onto negative (-) battery terminal.
2. Install access panels at the front and both sides of the enclosure. See [Access Panels](#).
3. See [Return To Service](#).

Schedule B Maintenance

NOTE: Perform Schedule B maintenance every two years or after 250 hours of service, whichever comes first. Before proceeding below, first perform all tasks listed under [Schedule A Maintenance](#).

NOTE: For general location of components, see [Component Locations](#).

Replacing Lubricating Oil and Oil Filter

Proceed as follows to replace lubricating oil and oil filter:

1. See [Figure 5-20](#). Remove oil drain hose from holding clamp (A). Use one wrench to hold hex on hose fitting (to prevent rotation), and use second wrench to remove drain plug.

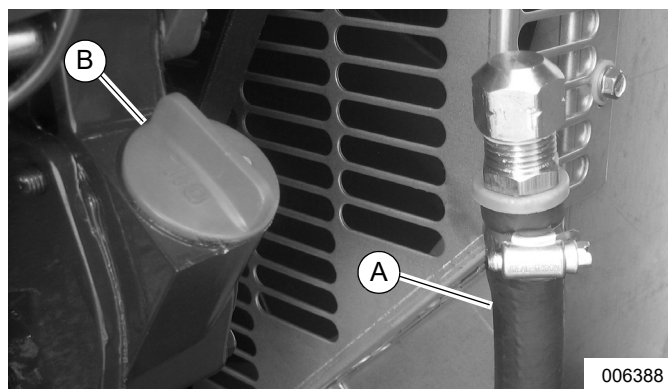

006388

Figure 5-20. Oil Fill Cap and Drain Hose (3.3L Engine)

2. Drain oil into a suitable container.

3. Install oil drain plug onto end of oil drain hose.
4. Install oil drain hose into holding clamp.
5. Turn oil filter counterclockwise to remove from oil filter adapter.
6. Apply a light coat of clean engine oil to gasket of **new** oil filter.
7. Install oil filter by hand until gasket just contacts oil filter adapter. Tighten oil filter an additional three-quarters to one full turn.
8. Remove oil fill cap (B) and fill engine with recommended oil. See [Engine Oil Recommendations](#).
9. Install oil fill cap.
10. Install negative battery cable (black) onto negative (-) battery terminal.
11. Pull up rubber flap covering fuse holder and install 7.5 amp fuse.
12. Press MANUAL on control panel to start engine.
13. Allow engine to run for one minute. Inspect for leaks while engine is running.
14. Press OFF on control panel. A red LED illuminates to verify system is OFF.
15. Wait a few minutes for engine to cool and to allow oil to drain back to the oil pan.
16. Check oil level and add oil as necessary. **DO NOT OVERFILL.**
17. Install oil fill cap.

NOTE: Dispose of used oil and oil filter as per national, state, or local codes.

Draining Fuel Filter and Inspecting Fuel Lines/ Hoses

Proceed as follows to drain fuel filter and inspect fuel lines:

1. See [Figure 5-21](#). Place a shop rag beneath fuel filter (A) to catch water or fuel drips.

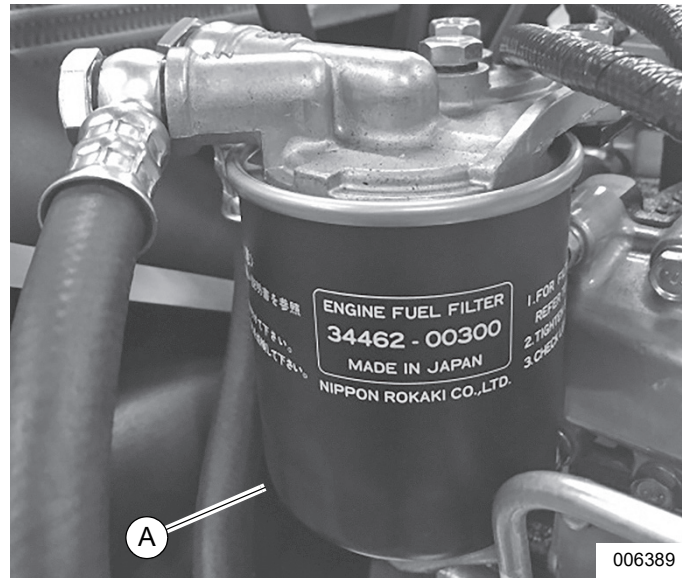

Figure 5-21. Drain Fuel Filter (2.5L Engine)

2. Turn fuel filter counterclockwise to remove from filter adapter.
3. Install **new** fuel filter by hand until gasket just contacts filter adapter. Tighten fuel filter an additional three-quarters to one full turn.

NOTE: Dispose of used filter per national, state, or local codes.

4. Inspect fuel filter and fuel lines/hoses for leaks. Tighten filter, fittings, and hose clamps if necessary.
5. Inspect fuel hoses for nicks, cuts, tears, or general deterioration. Replace as necessary
6. See [Priming Fuel System](#).

Priming Fuel System

See [Priming Fuel System](#).

Draining/Flushing Coolant System



WARNING

Risk of burns. Contents under pressure. Do not remove the radiator pressure cap while engine is hot. Doing so could result in death or serious injury. (000322a)

Proceed as follows to drain and flush coolant system:

NOTE: On 2.5L models, remove ten screws to release louvered air discharge panel on left side of enclosure.

1. Disconnect and empty coolant overflow reservoir.
2. Install and connect coolant overflow reservoir.
3. Slowly unscrew radiator cap.
4. See [Figure 5-22](#). Locate drain valve (A) at bottom left side of radiator. Turn hex fitting to open drain valve.
5. Remove coolant drain hose from holding clamp.
6. Use wrench to hold hex on hose fitting (to prevent rotation), and use second wrench to remove drain plug.
7. Drain coolant into a suitable container.
8. Install plug at end of coolant drain hose.
9. Install coolant drain hose in holding clamp.
10. Turn hex fitting to close radiator drain valve.
11. Obtain at least 3.0 gal (11.4 L) of coolant. See [Engine](#).
12. Turn and remove plastic cover at top of enclosure and insert funnel into filler neck (B).
13. Slowly pour coolant into filler neck until radiator is full.
14. Install radiator cap.
15. Press MANUAL on control panel to start engine. A blue LED illuminates to verify system is in MANUAL.
16. Allow engine to run until thermostat opens, as indicated by heating of top radiator hose.
17. Inspect coolant hoses for leaks. Tighten clamps, if necessary.
18. Press OFF on control panel to shut engine down.
19. Wait five minutes for engine to cool.
20. Repeat steps 4-20 to drain and refill cooling system.
21. Install plastic cover at top of enclosure and turn until tight.
22. Inspect hoses for nicks, cuts, tears, or general deterioration. Replace as necessary.

NOTE: On 2.5L models, start ten screws to install louvered air discharge panel. Alternately tighten screws to 90 **in-lbs** (10 Nm) using a crosswise pattern.

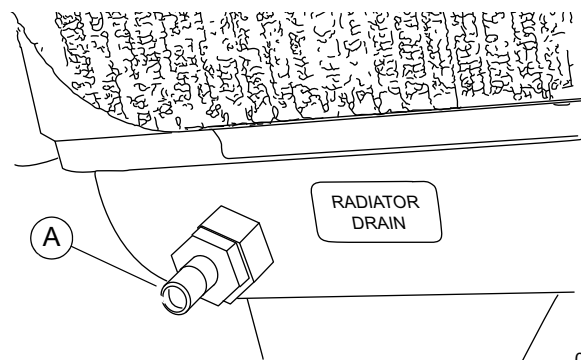

001493

NOTE: Drain hose removed for illustration purposes.

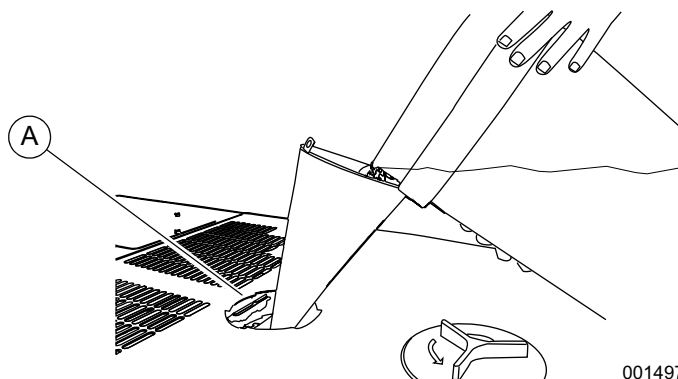

001497

Figure 5-22. Drain/Fill Coolant System

Final Instructions

1. Install left and right side access panels. See [Access Panels](#).
2. See [Return To Service](#).

Schedule C Maintenance

NOTE: Perform Schedule C maintenance after 1,000 hours of service. Before proceeding below, first perform all tasks listed under Schedule A Maintenance and Schedule B Maintenance.

NOTE: The following procedures require special tools and skills. Contact an IASD to perform these tasks.

- Inspect fuel tank
- Check/adjust fuel injection valve pressure
- Check/adjust fuel injection pump timing
- Adjust intake/exhaust valve clearance
- Tighten critical fasteners

NOTE: Reset A-B-C/Year time maintenance schedule counter using the Dealer Sub Menu (password required).

Return To Service

Proceed as follows to return unit to service after inspection, maintenance, or service of generator:

1. See **Figure 5-23**. Pull up rubber flap covering fuse holder (A) and install 7.5 amp fuse.

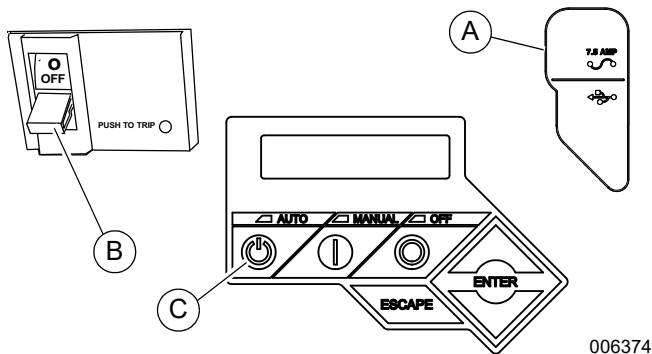

Figure 5-23. Generator Control Panel

2. Install T1 fuse in transfer switch.
3. Verify both auxiliary shutdown switches are ON (I).
4. Press AUTO (C) on control panel. A green LED illuminates to verify system is in AUTO.
5. Set generator MLCB (generator disconnect) to ON (CLOSED).
6. Close viewing window.
7. Remove DO NOT OPERATE tag or placard from both control panel and transfer switch.
8. Reset time and date.

Section 6: Troubleshooting

Engine Troubleshooting

Problem	Cause	Correction
Engine will not crank	Blown fuse.	Replace 7.5 amp fuse in generator control panel. Correct short circuit condition if fuse blows again.
	Loose, corroded, or faulty battery cables.	Tighten, clean or replace as necessary. Contact an IASD.
	Faulty starter contact.	
	Faulty starter motor.	
	Discharged battery.	Charge or replace battery.
Engine cranks but will not start	No fuel.	Replenish fuel. Turn on fuel valve.
	Faulty fuel solenoid.	Contact an IASD.
	Open F1 5 amp fuse.	Replace F1 5 amp fuse if fuse blows again. Contact an IASD.
	Faulty fuel system.	Contact an IASD.
	No fuel to pump.	Prime fuel system. Contact an IASD.
Engine starts hard and runs rough	Air cleaner plugged or damaged.	Inspect/replace air cleaner.
Unit is set to OFF, but engine continues to run	Faulty keypad.	Contact an IASD.
	Faulty control board.	
No AC output from generator	Generator MLCB (generator disconnect) is OFF (OPEN).	Reset generator MLCB (generator disconnect) to ON (CLOSED).
	Generator internal fault.	Contact an IASD.
No transfer to standby after utility source failure	Faulty transfer switch coil.	Contact an IASD.
	Faulty transfer relay.	
	Transfer relay circuit open.	
	Faulty control logic board.	
Unit consumes large amounts of oil	Excessive engine oil.	Adjust oil to correct level.
	Faulty engine breather.	Contact an IASD.
	Incorrect oil type or viscosity.	See Engine Oil Recommendations .
	Damaged gasket, seal, or hose.	Inspect for oil leaks.

Controller Troubleshooting

Active Alarm	Problem	Solution
NOT ACTIVATED	Unit will not start in AUTO with utility loss.	See Activate Unit .
AUXILIARY SHUTDOWN	Unit will not start in AUTO with utility loss.	Verify both auxiliary shutdown switches are ON (I).
NONE	Unit running in AUTO but no power in house.	Check MLCB. Contact an IASD if MLCB is ON.
NONE	Unit will not start in AUTO with utility loss.	Check screen for start delay countdown. If start up delay is greater than expected, contact an IASD to adjust from 2 to 1500 seconds.
HIGH TEMPERATURE	Unit shuts down during operation.	Inspect ventilation around intake, exhaust, and rear of generator. Contact an IASD if no obstruction is found.
OVERLOAD	Unit shuts down during operation.	Clear alarm and remove household loads from generator. Put back in AUTO and start.
RPM SENSE LOSS	Unit was running and shuts down, attempts to restart.	Clear alarm and remove household loads from generator. Put in AUTO and start. If problem returns, contact an IASD to investigate possible fuel issue.
LOW OIL PRESSURE	Unit will not start in AUTO with utility loss.	Check oil level. Add oil per owner's manual. Contact an IASD if oil level is correct.
RPM SENSE LOSS	Unit will not start in AUTO with utility loss.	Clear alarm. From MAIN menu on control panel, navigate to BATTERY MENU. Contact an IASD if battery is GOOD. Replace battery if CHECK BATTERY is displayed.
OVERCRANK	Unit will not start in AUTO with utility loss.	Clear alarm. Attempt to start unit in MANUAL. If it does not start or starts and runs rough, contact an IASD.
FUSE PROBLEM	Unit will not start in AUTO with utility loss.	Check ATO 7.5 amp fuse. Replace with same type fuse if bad. Contact an IASD if fuse is good.
OVERSPEED	Unit will not start in AUTO with utility loss.	Contact an IASD.
UNDER VOLTAGE	Unit will not start in AUTO with utility loss.	Contact an IASD.
UNDERSPEED	Unit will not start in AUTO with utility loss.	Contact an IASD.
MISWIRE	Unit will not start in AUTO with utility loss.	Contact an IASD.
OVERVOLTAGE	Unit will not start in AUTO with utility loss.	Contact an IASD.
LOW BATTERY	Warning active.	Clear alarm. From MAIN menu on control panel, navigate to BATTERY MENU. Contact an IASD if battery is GOOD. Replace battery if CHECK BATTERY is displayed.
BATTERY PROBLEM	Warning active.	Contact an IASD.
CHARGER WARNING	Warning active.	Contact an IASD.
SERVICE SCHEDULE A	Warning active.	Perform SERVICE SCHEDULE A maintenance; press ENTER to clear.
SERVICE SCHEDULE B	Warning active.	Perform SERVICE SCHEDULE B maintenance; press ENTER to clear.
SERVICE SCHEDULE C	Warning active.	Perform SERVICE SCHEDULE C maintenance; press ENTER to clear.

Removal From Service During Utility Outages

If, during prolonged utility outages, the user wishes to remove unit from service to conserve fuel, reduce run hours, or to perform maintenance tasks, then complete the steps listed below.

IMPORTANT NOTE: Failure to abide by this procedure can result in equipment damage.

Remove From Service

Proceed as follows to remove generator from service while running in AUTO and Online:

1. Set utility MLCB to OFF (OPEN).
2. Open viewing window. See [Opening Viewing Window](#).
3. Set generator MLCB (generator disconnect) to OFF (OPEN).
4. Press OFF on control panel. A red LED illuminates to verify system is OFF.

NOTE: Complete the additional steps listed below if inspection and/or maintenance tasks are to be performed.

5. Remove T1 fuse from transfer switch.
6. Pull up rubber flap covering fuse holder and remove 7.5 amp fuse.
7. Remove black negative battery cable from negative (-) battery terminal.
8. Place a DO NOT OPERATE tag or placard on both the generator control panel and transfer switch.

Return to Service

Proceed as follows to return generator to service:

NOTE: If inspection and/or maintenance tasks were performed, start with step 1. If unit was shut down to conserve fuel or to reduce run hours, start at step 5.

1. Install black negative battery cable onto negative (-) battery terminal.
2. Pull up rubber flap covering fuse holder and install 7.5 amp fuse.
3. Install T1 fuse in transfer switch.
4. Remove DO NOT OPERATE tag or placard from both control panel and transfer switch.
5. Press AUTO on control panel. A green LED illuminates to verify system is in AUTO mode. Allow generator to start and run for a few minutes.
6. Set generator MLCB (generator disconnect) to ON (CLOSED).
7. Turn utility MLCB to ON (CLOSED).
8. Close viewing window.

Storage

Prepare For Storage



WARNING

Explosion. Batteries emit explosive gases. Always disconnect negative battery cable first to avoid spark. Failure to do so could result in death or serious injury. (000238)

Proceed as follows to prepare for storage if generator cannot be exercised once every **seven** days and will be out of service longer than 90 days:

1. Open viewing window. See [Opening Viewing Window](#).
2. Press MANUAL on control panel to start engine. A blue LED illuminates to verify system is in MANUAL mode.
3. Allow engine to run until it reaches normal operating temperature.
4. Press OFF on control panel. A red LED illuminates to verify system is OFF.
5. Set generator MLCB (generator disconnect) to OFF (OPEN).
6. Pull up rubber flap covering fuse holder and remove 7.5 amp fuse.
7. Turn off utility power to transfer switch.
8. Place a DO NOT OPERATE tag or placard on both generator control panel and transfer switch.
9. Wait five minutes for engine to cool.
10. Remove right side access panel. See [Removing Side Access Panels](#).
11. Remove oil drain hose from holding clamp.
12. Use one wrench to hold hex on hose fitting (to prevent rotation), and use second wrench to remove drain plug.
13. Drain oil into a suitable container.
14. Install oil drain plug onto end of oil drain hose.
15. Install oil drain hose into holding clamp.
16. Turn oil filter counterclockwise to remove from oil filter adapter.
17. Apply a light coat of clean engine oil to gasket of **new** oil filter.
18. Install oil filter by hand until gasket just contacts oil filter adapter. Tighten oil filter an additional three-quarter to one full turn.
19. Remove oil fill cap and fill engine with recommended oil. See [Engine Oil Recommendations](#).
20. Install oil fill cap.
21. Install right side access panel. See [Removing Side Access Panels](#).

NOTE: Dispose of used oil and oil filter as per national, state, or local codes.

22. Remove left side access panel. See [Removing Side Access Panels](#).

NOTE: On 2.5L models, remove ten screws to release louvered air intake panel.

23. Remove black negative battery cable from negative (-) battery terminal.
24. Remove red positive battery cable from positive (+) battery terminal.
25. Remove two screws to release battery hold-down clamp from platform, or loosen strap and position away from tray.
26. Remove battery and store in a cool, dry room.
27. Install left side access panel. See [Removing Side Access Panels](#).

NOTE: On 2.5L models, start ten screws to install louvered air intake panel. Alternately tighten screws to 90 in-lbs (10 Nm).

28. Thoroughly clean and wipe down generator.

Return to Service From Storage



WARNING

Explosion. Batteries emit explosive gases. Always connect positive battery cable first to avoid spark. Failure to do so could result in death or serious injury. (000133)



CAUTION

Equipment damage. Do not make battery connections in reverse. Doing so will result in equipment damage. (000167a)

Proceed as follows to return unit to service after storage:

1. Thoroughly clean and wipe down generator.
2. Remove left side access panel. See [Removing Side Access Panels](#).

NOTE: On 2.5L models, remove ten screws to release louvered air intake panel.

3. Install battery onto tray oriented with negative (-) battery post toward front of enclosure.
4. Install two screws with nylon washers to secure battery hold-down clamp to tray, or tighten strap over top of battery.
5. Check battery. See [Checking Battery Condition/ Fluid Level](#).
6. Install positive battery cable onto positive (+) battery terminal.

7. Install negative battery cable onto negative (-) battery terminal.
8. Install left side access panel. See [Removing Side Access Panels](#).

NOTE: On 2.5L models, start ten screws to install louvered air intake panel. Alternately tighten screws to 90 in-lbs (10 Nm).

9. Remove right side access panel. See [Removing Side Access Panels](#).
10. Check oil level and add oil as necessary. **DO NOT OVERFILL.**
11. Open viewing window. See [Opening Viewing Window](#).
12. Pull up rubber flap covering fuse holder and install 7.5 amp fuse.
13. Set generator MLCB (generator disconnect) to ON (CLOSED).
14. Press MANUAL on control panel to start engine. A blue LED illuminates to verify system is in MANUAL.
15. Allow engine to run until it reaches normal operating temperature. Inspect for leaks while engine is running.
16. Press OFF on control panel. A red LED illuminates to verify system is OFF.
17. Install right side access panel. See [Removing Side Access Panels](#).
18. Turn on utility power to transfer switch.
19. Press AUTO on control panel. A green LED illuminates to verify system is in AUTO.
20. Reset time and date.
21. Close viewing window.

Attention After Submersion

Do NOT start and operate generator if it has been submerged in water. Have an IASD thoroughly clean, dry, and inspect generator following any submersion. If structure (home) has been flooded, it should be inspected by a certified electrician to verify there will not be any electrical problems during generator operation or when utility power is returned.

Attention After Fuel Spillage

Contact reputable local company that performs clean up and disposal services.

Contaminated Fuel Disposal

Contact reputable local company that performs purging, burnishing, and disposal services.

Part No. 10000019179 Rev. C 06/03/2020
©2020 Generac Power Systems, Inc.
All rights reserved.
Specifications are subject to change without notice.
No reproduction allowed in any form without prior written
consent from Generac Power Systems, Inc.



Generac Power Systems, Inc.
S45 W29290 Hwy. 59
Waukesha, WI 53189
1-888-GENERAC (1-888-436-3722)
www.generac.com