

EMEVSE1UL



Description

Level 2 electric vehicle charging station charges any EV up to 40 amps with NEMA 14-50P or up to 48 amps with hardwired installation. Works with all electric cars. Installs easily indoors or out. Use the Emporia app to schedule charging when electricity is cheapest and see all your charging data and energy consumption in one place.

Features

- Level 2 / 48 amp
- Compatible with any EV (adapter required for Tesla)
- Schedule charging with app
- Track energy use with app
- Integrated cable management
- For residential and commercial
- 2.4 GHz 802.11b/g/n WiFi

Specifications

Input Voltage	208/240VAC 50/60Hz
Power Charge	11.5kW (240V/48A) / 9.6kW (240V/40A) / 10kW (208V/48A) / 8.3kW (208V/40A)
Required Breaker	Dedicated 50A+ dual pole for 40A Dedicated 60A+ dual pole for 48A
Connector	24' cable SAE J1772 connector
Power Wiring	NEMA Type 14-50P (up to 40A) with 24" cable compliant with 2017 NEC Section 625.17(A)(3) / Hardwired (up to 48A)
Enclosure	Watertight NEMA Type 4 indoor/outdoor
Temp Range	-22°F to 122°F (-30°C to 50°C)

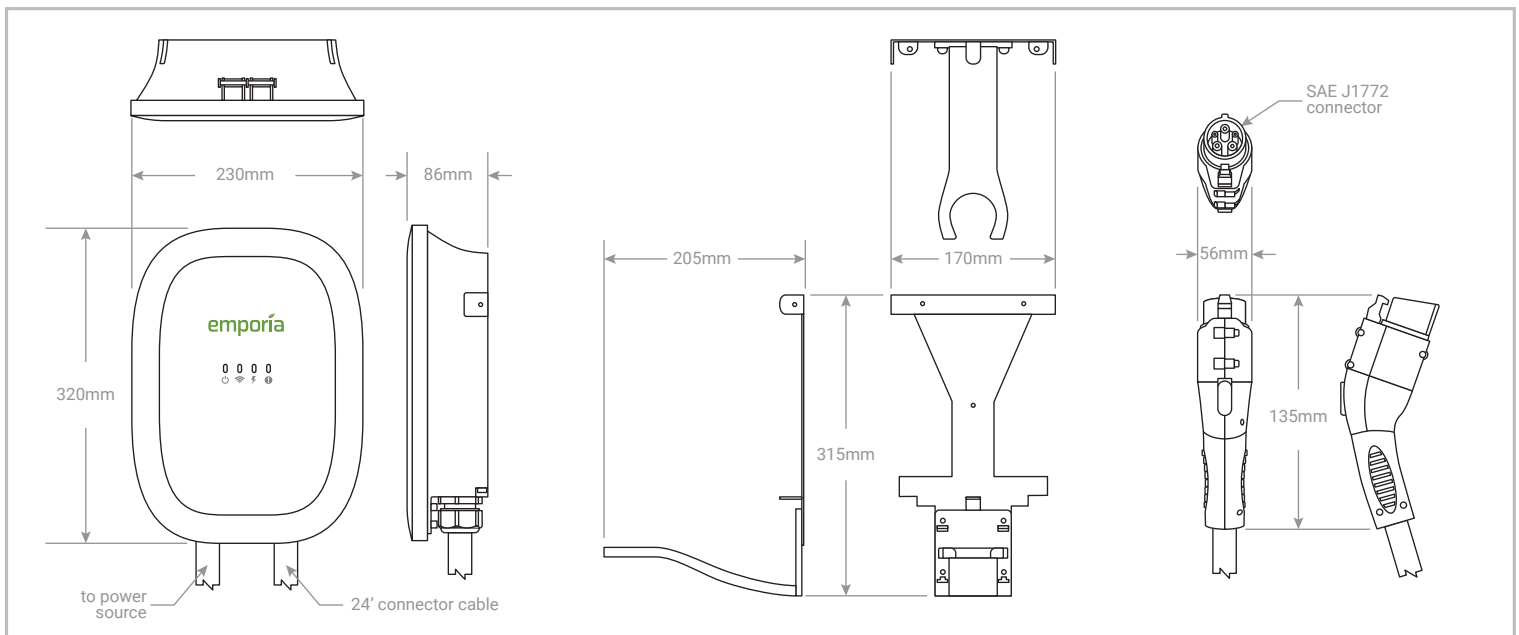

Safety Features



The **Emporia Smart Home EV Charger** is manufactured to meet the safety criteria defined by these international standards: **NEC 625** - Electric Vehicle Charging System Equipment; **SAE J1772** - Electric Vehicle Conductive Charge Coupler Standard; **UL 817** - Cord Sets and Power-Supply Cords, **UL 991** - Safety Tests for Safety-Related Controls Employing Solid-State Devices; **UL 2231** - Standard for Personnel Protection Systems for Electric Vehicle Supply Circuit; **UL 2251** - Standard for Plugs, Receptacles and Couplers for Electric Vehicles, and **UL 2594** - Standard for Electric Vehicle Supply Equipment. The Emporia EV Charger employs the following safety features as defined by these standards:

Ground Fault Interrupt	15mA to 20mA trip sensitivity to protect against electric shock.
Internal Temperature	Charging station internal temperature is continuously monitored and shut off if the board temperature exceeds 98° C.
Missing Ground Detection	Safety ground is constantly monitored during operation. Charging is shut off if the ground is missing.
Pilot Signal	EV connector / cable is de-energized when exposed to a strain that could result in the exposure of live parts.
Power interlock	EV connector / cable is de-energized when uncoupled from EV.
Self Check	Sequence performed during start up, every three hours, and before charging to ensure unit is working properly and safely upon power-up.
Stuck Relay Detection	Check to ensure relays are functioning properly and providing proper power gating.
Surge Detection	Constantly monitors for power surges during operation. Charging is shut off if a surge is detected.
Ventilation Required	Checks for ventilation requests from EV and prevents charging if ventilation is not available.