

WPX3400

Gas Pressure Washer

DO NOT RETURN THIS PRODUCT TO THE STORE

If you have questions or need assistance, please call customer service at 855-944-3571.

INTRODUCTION

TABLE OF CONTENTS

INTRODUCTION

DISCLAIMERS	2
ALL RIGHTS RESERVED	2
SPECIFICATIONS	3

SAFETY

SAFETY DEFINITIONS	4
SAFETY SYMBOLS	4
FUEL SAFETY	5

COMPONENTS

COMPONENTS	7
------------------	---

ASSEMBLY

CARTON CONTENTS	8
INSTALL HANDLE	8
INSTALL WHEELS	8
INSTALL MOUNTING FOOT AND LOWER GUN HOLDER	9
INSTALL UPPER GUN HOLDER	9
INSERT SPRAY NOZZLES	9
ASSEMBLE SPRAY GUN AND HOSE	9
INITIAL OIL FILL	10
FUEL	10
CONNECT THE GARDEN HOSE	11

OPERATION

PRESSURE WASHER LOCATION	12
STARTING THE ENGINE	12
STOPPING THE PRESSURE WASHER	12

SELECTING NOZZLES	13
CHANGING THE NOZZLE	13
SPRAYING TIPS	13
DETERGENT USE	14
TRANSPORTING	14

MAINTENANCE

MAINTENANCE SCHEDULE	15
CLEANING THE PRESSURE WASHER	15
AIR FILTER MAINTENANCE	15
ENGINE OIL LEVEL CHECK	16
ENGINE OIL CHANGE	16
SPARK PLUG MAINTENANCE	17
SPARK ARRESTOR SERVICE	17
STORAGE	18
WINTER STORAGE	18
VALVE CLEARANCE	19

TROUBLESHOOTING

TROUBLESHOOTING	20
-----------------------	----

EXPLODED VIEW

EXPLODED VIEW A	21
EXPLODED VIEW B	23

⚠ WARNING: Operating, servicing, and maintaining this equipment can expose you to chemicals including engine exhaust, carbon monoxide, phthalates, and lead, which are known to the State of California to cause cancer and birth defects or other reproductive harm. To minimize exposure, avoid breathing exhaust, and wear gloves or wash your hands frequently when servicing this equipment. For more information go to www.P65warnings.ca.gov.

DISCLAIMERS

All information, illustrations, and specifications in this manual were in effect at the time of publishing. The illustrations used in this manual are intended as representative reference views only. We reserve the right to make any specification or design change without notice.

ALL RIGHTS RESERVED

All rights reserved. No reproduction allowed in any form without written permission from Westinghouse Outdoor Power Equipment, LLC.

⚠ DANGER



Read this manual before using or performing maintenance on this product. Failure to follow the instructions and safety precautions in this manual can result in serious injury or death.

SAVE THESE INSTRUCTIONS

INTRODUCTION

SPECIFICATIONS

Specifications	
Pressure (PSI/BAR):	3400/234
Flow Rate (GPM/LPM):	2.6/9.84
Water Temperature (°F/°C):	104°/40° Max
Hose Length (ft):	25
Soap Tank Capacity (Gal/L):	0.42/1.6
Engine Displacement (cc):	212
Starting Type:	Recoil
Fuel Capacity (Gal/L):	0.87/3.3
Fuel Type:	87–93 octane*
Oil Capacity (Oz/L):	20/0.6
Oil Type:	SAE 10W-30
Spark Plug:	F7TC
Spark Plug Gap:	0.024 – 0.032 in. (0.60 – 0.80 mm)
Nozzles:	0°, 15°, 25°, 40°, Soap
Certifications:	<ul style="list-style-type: none">• EPA• CARB

*Ethanol content of 10% or less. DO NOT use E15 or E85.

NOTICE

This product is designed and rated for continuous operation at ambient temperatures up to 104°F (40°C). If needed, this product can be operated at temperatures ranging from 5°F (15°C)–122°F (50°C) for short periods. If the product is exposed to temperatures outside of this range during storage, it should be brought back within this range before operation. This product must always be operated outdoors in a well-ventilated area and far away from doors, windows, and other vents.

Maximum power decreases about 3.5% for each 1,000 feet above sea level, and will also decrease about 1% for each 10°F (6°C) above 60°F (16°C) ambient temperature.

PRODUCT REGISTRATION

For trouble-free warranty coverage, it is important to register your Westinghouse pressure washer.

You can register by:

- Completing and mailing the product registration card included in the carton.
- Registering your product online at: <https://westinghouseoutdoorpower.com/pages/warranty-registration>
- Sending the following product information to:

Westinghouse Outdoor Power
Warranty registration
777 Manor Park Drive
Columbus, OH 43228

For Your Records

Date of Purchase: _____

Model Number: _____

Serial Number: _____

Place of Purchase: _____

IMPORTANT: Keep your purchase receipt for trouble-free warranty coverage.

SAFETY

SAFETY DEFINITIONS

The words DANGER, WARNING, CAUTION, and NOTICE are used throughout this manual to highlight important information. Make sure that the meanings of this safety information is known to all who operate, perform maintenance on, or are near the pressure washer.



This safety alert symbol appears with most safety statements. It means attention, become alert, your safety is involved! Please read and abide by the message that follows the safety alerts symbol.

DANGER

Indicates a hazardous situation which, if not avoided, will result in death or serious injury.

WARNING

Indicates a hazardous situation which, if not avoided, could result in death or serious injury.

CAUTION

Indicates a hazardous situation which, if not avoided, could result in minor or moderate injury.

NOTICE

Indicates a situation which can cause damage to the pressure washer, personal property, and/or the environment, or cause the equipment to operate improperly.

Note: Indicates a procedure, practice or condition that should be followed for the pressure washer to function in the manner intended.

SAFETY SYMBOLS

Follow all safety information contained in this manual and on the pressure washer.

Symbol	Description
	Safety Alert Symbol
	Electrocution Hazard
	Asphyxiation Hazard
	Burn Hazard. Do not touch hot surfaces.
	Electrical Shock Hazard
	Fire Hazard
	Maintain Safe Distance
	Injection Risk. Do not direct water stream at people or pets.
	Kickback. Hold spray gun securely
	Lifting Hazard
	Read Manufacturer's Instructions
	Wear eye and ear protection

DANGER

CARBON MONOXIDE – using this product indoors CAN KILL YOU IN MINUTES. Operate this product outdoors only in a well ventilated area.

DO NOT operate the product inside any building, including garages, basements, crawlspaces and sheds, enclosure, or compartment. DO NOT allow exhaust fumes to enter a confined area through windows, doors, vents, or other openings.

SAFETY

FUEL SAFETY

DANGER

Fire and explosion hazard. Gasoline is highly explosive and flammable and can cause severe burns or death.

- In case of a gas fire, do not attempt to extinguish the flame if the fuel tank valve is in the ON position. Introducing an extinguisher to a pressure washer with an open fuel valve could create an explosion hazard.
- Gas has a distinctive odor, this will help detect potential leaks quickly.
- Gas vapors can cause a fire if ignited.
- Gasoline is a skin irritant and needs to be cleaned up immediately if it comes in contact with the skin.
- Gasoline and gasoline vapors are extremely flammable and explosive under certain conditions.
- ALWAYS refuel the pressure washer outdoors, in a well-ventilated area.
- NEVER remove the fuel cap with the engine running.
- NEVER refuel the pressure washer while the engine is running. Always turn the engine off and allow the pressure washer to cool for at least two minutes before refueling.
- Only fill fuel tank with gasoline.
- Keep sparks, open flames or other form of ignition (such as match, cigarette, static electric source) away when refueling.
- NEVER overfill the fuel tank. Leave room for fuel to expand. Overfilling the fuel tank can result in a sudden overflow of gasoline and result in spilled gasoline coming in contact with HOT surfaces.
- Spilled fuel can ignite. If fuel is spilled on the pressure washer, wipe up any spills immediately. Dispose of rag properly. Allow area of spilled fuel to dry before operating the pressure washer.
- Wear eye protection while refueling.
- NEVER use gasoline as a cleaning agent.
- Store any containers containing gasoline in a well-ventilated area, away from any combustibles or source of ignition.
- Check for fuel leaks after refueling.
- Never operate the engine if a fuel leak is discovered.
- Store fuel in a container approved for gasoline.
- Do not smoke when filling the pressure washer with gasoline.
- Do not allow the gas tank to overflow when filling.
- Shut down the engine and allow it to cool for two minutes before adding gasoline or oil to the pressure washer.
- Wipe spilled fuel from the unit.

- Never attempt to burn off spilled fuel.
- Store any containers containing gasoline in a well-ventilated area, away from any combustibles or source of ignition.

GENERAL SAFETY PRECAUTIONS

- Do not operate when you are tired or under the influence of drugs, alcohol, or medication.
- Always wear safety goggles or safety glasses with side shields, and as necessary a full face shield as well as full ear protection when operating this product.
- If you begin to feel sick, dizzy, or weak while using the pressure washer, move to fresh air IMMEDIATELY. See a doctor, as you can have carbon monoxide poisoning.
- Only use OUTSIDE and far away from windows, doors, and vents as recommended by the US Department of Health and Human Services Centers for Disease Control and Prevention. Your specific home and/or wind conditions may require additional distance.
- While operating and storing, keep at least five feet of clearance on all sides of pressure washer, including overhead. Allow the pressure washer to cool a minimum of 30 minutes before storage. Heat created by the muffler and exhaust gases could be hot enough to cause serious burns and/or ignite combustible objects.
- Do not touch the muffler or engine. They are very HOT and will cause severe burns. Do not put body parts or any flammable or combustible materials in the direct path of the exhaust.
- Always remove any tools or other service equipment used during maintenance away from the unit before operating.
- Avoid skin contact with engine oil or gasoline. Wear protective clothing and equipment. Wash all exposed skin with soap and water.

DANGER

Risk of injection or injury. High pressure jets can be dangerous if subject to misuse. DO NOT direct discharge stream at persons, animals, electrical devices, or the machine itself. ALWAYS point spray gun in safe direction. Every time you stop the engine, depress the spray gun trigger to relieve pressure.

DANGER

NEVER spray flammable liquids or use pressure washer in areas containing combustible dust, liquids, or vapor. NEVER operate this machine in a closed building or in or near an explosive environment.

- The wheels are only intended for hand transport. The wheels are not suitable for towing the pressure washer either on or off-road

SAFETY

⚠️ WARNING

Contact with electrical power source can cause electric shock or burn. NEVER spray in the direction of or near a power source/electrical outlet.

- NEVER disconnect the high pressure discharge hose from the machine while the system is pressurized.
- DO NOT let water in the pump freeze. See Storage section in the manual for instructions regarding winter storage.
- If water has frozen in the pressure washer, thaw the pressure washer in a warm room before starting.
- Use the pressure washer only for intended uses.
- Operate only on level surfaces.
- DO NOT expose pressure washer to excessive moisture, dust, or dirt.
- DO NOT allow any material to block the cooling slots.
- DO NOT use the pressure washer if the unit sparks, smokes, emits flames, or vibrates excessively.

When starting the pressure washer:

- NEVER run the unit dry. Be sure the water supply is completely turned on before operating the unit.
- DO NOT pour hot water on or into the pump; internal parts will be damaged and your warranty will be voided. ONLY use cold water.
- Use only on a level surface.
- Make sure there is proper drainage to dissipate water.
- Make sure that the fuel cap, air filter, spark plug, fuel lines, and exhaust system are properly in place.
- If you spill any gasoline on the tank, allow it to fully evaporate before operating.

When transporting or servicing the pressure washer:

- Disconnect the spark boot to prevent accidental starting.

When storing the pressure washer:

- Store away from sparks, open flames, pilot lights, heat, and other sources of ignition.
- Do not store gasoline near furnaces, water heaters, or any other appliances that produce heat or have automatic ignitions.

NOTICE

Water under high pressure can damage fragile surfaces. ALWAYS practice on a inconspicuous test area to understand when damage may occur.

⚠️ WARNING

Use of pressure washers can create wet walking surfaces. While using a pressure washer, forces from the gun can cause you to loose footing and fall.

⚠️ WARNING

High pressure spray can splash back at operator or propel objects.

- NEVER allow children to operate any pressure washer or play nearby.
- NEVER leave spray gun unattended while machine is running or until after engine has been turned off and pressure has been relieved from the spray gun.
- NEVER repair high pressure hose, replace it.
- NEVER repair leaking connections with sealant, replace damaged O-rings.
- NEVER use spray gun with a damaged or altered trigger lock.
- NEVER: secure the trigger in the open / spray position.
- ALWAYS keep high pressure hose connected to spray gun and pump while in use.
- ALWAYS make sure that the spray gun nozzle is properly attached to the lance.
- ALWAYS wear safety goggles when operating this equipment. Safety goggles cover the sides, top and bottom of the eyes. Don't confuse safety glasses for goggles.
- Use only on a level surface.
- DO NOT use on elevated surface where kickback could result in a serious fall.
- ALWAYS grasp the gun with two hands to prevent potential injury do to the high pressure from the gun.

COMPONENTS

COMPONENTS

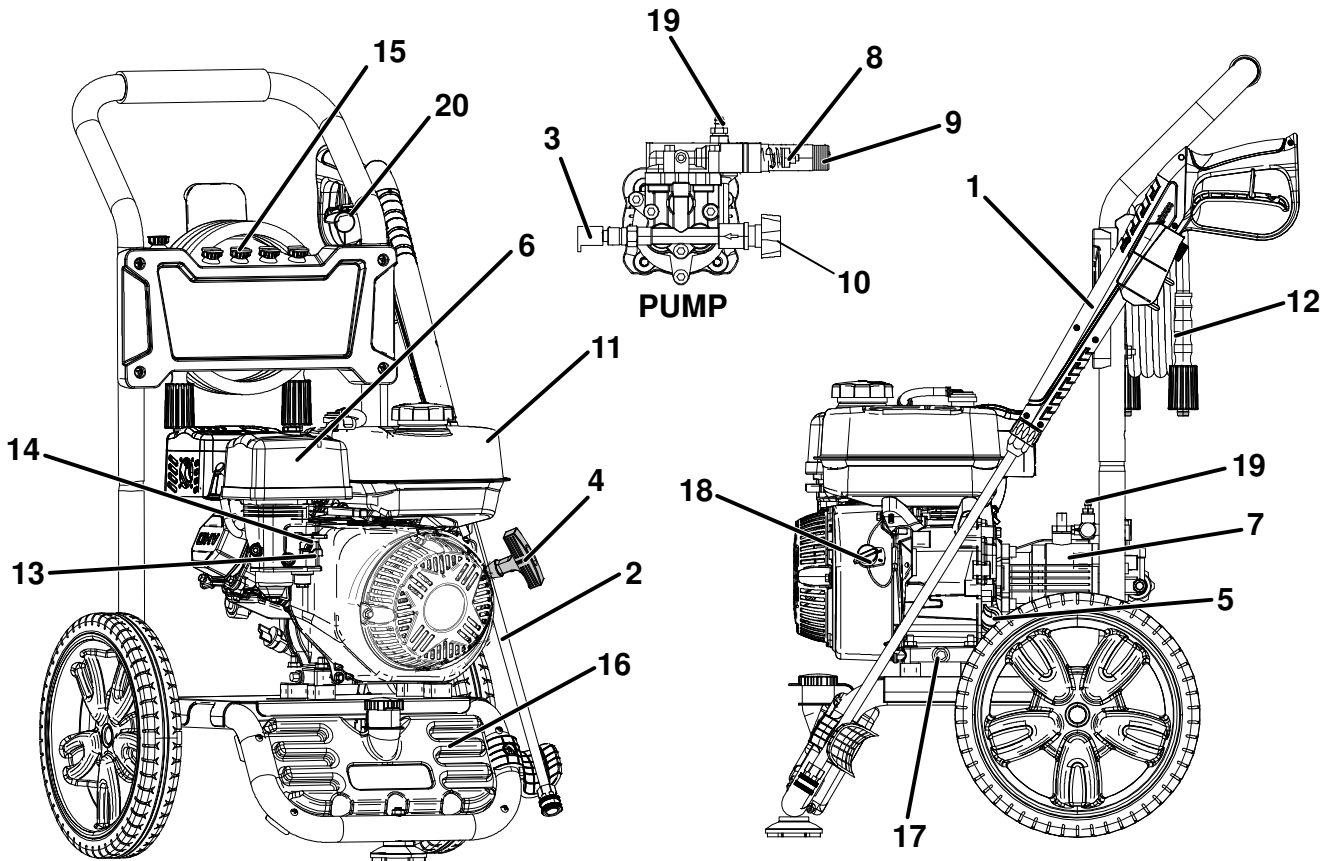

1. **Spray Gun:** Controls the application of water onto the surface with trigger. Includes trigger lock.
2. **Gun Lance:** Connects to end of spray gun and works with pressure nozzles included.
3. **Thermal Relief Valve:** When water reaches 125° F warm water will discharge from pump onto ground to help prevent internal pump damage.
4. **Recoil Handle:** Pull to start engine.
5. **Oil Dipstick/Filler Neck:** Used to check/fill oil.
6. **Air Filter**
7. **Pump:** Generates high pressure.
8. **Unloader Valve:** Controls pressure output.
9. **High Pressure Outlet:** Connection for high pressure hose.
10. **Water Inlet:** Connection for garden hose.
11. **Fuel Tank:** Fill with regular unleaded fuel. Do not overfill.
12. **High Pressure Hose**
13. **Fuel On/Off Switch:** Turns fuel supply to the engine on and off.
14. **Choke:** Prepares a cold engine for starting.
15. **Nozzles:** Varying sizes for various high pressure cleaning applications.
16. **Detergent Tank:** Siphons detergent into the low pressure stream. Automatically turns on when using black soap nozzle. Only use pressure washer safe detergent.
17. **Oil Drain Plug:** Used to drain engine oil.
18. **Engine On/Off Switch:** Turn switch to the ON position before using the recoil starter. Turn to the OFF position to stop the engine.
19. **Detergent Hose Connection Barb:** Connects detergent tank to pump.
20. **Nozzle Cleaning Tool:** Used to clean nozzles.

ASSEMBLY

CARTON CONTENTS

⚠ CAUTION

Weight hazard. Always have assistance when lifting the pressure washer.

1. Carefully open the carton.
2. Remove and save the carton contents.
3. Remove and discard the packing tray.
4. Unfold the top of the plastic bag enclosing the pressure washer.
5. Carefully cut the vertical corners of the carton.
6. Recycle or dispose of the packaging materials properly.

CARTON CONTENTS

Item	Quantity
• User manual	1
• Quick Start Guide	1
• Bottle 10W-30 oil	1
• Bottle funnel tip	1
• Spray gun	1
• Spray gun lance	1
• Handle	1
• High pressure hose	1
• Mounting foot	1
• Nozzle cleaning tool	1
• Spray nozzles	5
• Nut, M8	1
• Spray gun upper holder	1
• Push rivet	1
• Spray gun lower holder	1
• Bolt and nut, M6	1

If any parts are missing, contact our service team at service@wpowerreq.com or call 1-855-944-3571.

INSTALL HANDLE

Install the handle on the lower frame with the decal side facing the engine. Slide the handle downward until the spring buttons click into place through the holes in the handle.



INSTALL MOUNTING FOOT AND LOWER GUN HOLDER

Install the mounting foot and secure with the M8 Nut. Attach the lower gun holder with the M6 screw, washers, and nut.

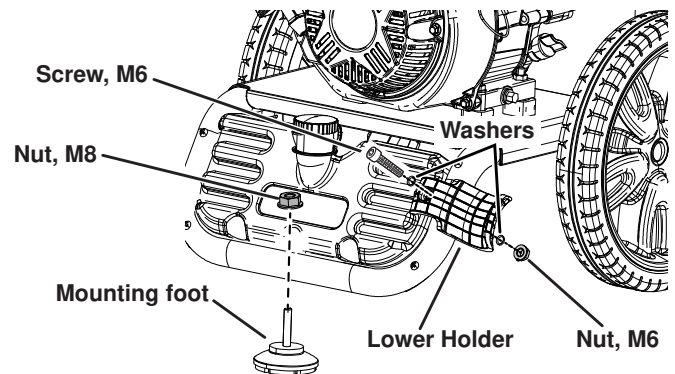

ASSEMBLY

INSTALL UPPER GUN HOLDER

From the front of the unit, remove top-right bolt, washers, and nut. Reinstall with the upper spray gun holder. From the rear of the unit, install the push rivet as shown.

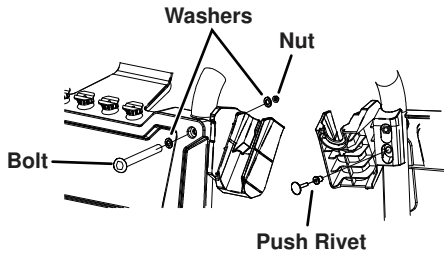

INSERT SPRAY NOZZLES

Insert the colored nozzles into the corresponding holders on the top of the pressure washer.

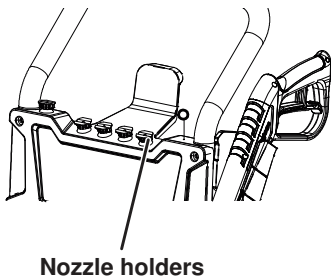

ASSEMBLE SPRAY GUN AND HOSE

1. Install the spray lance on the spray gun. Tighten the spray gun collar hand-tight. DO NOT over-tighten.
2. Install the high-pressure hose and tighten the collar. DO NOT over-tighten.

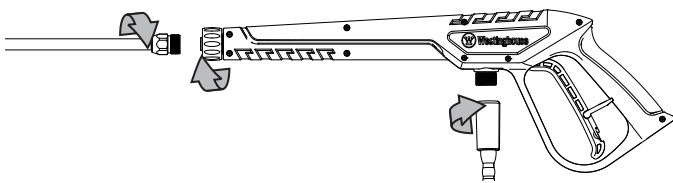

3. Engage the trigger lock in the safe position.

Note: The trigger lock prevents the spray gun from being triggered accidentally. Push the lock fully up to engage it.

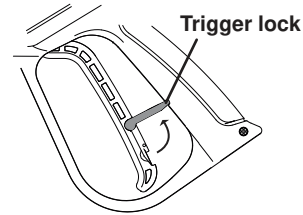

4. Select desired nozzle for application. Pull back the quick-connect collar at the end of the spray lance. Insert the nozzle then release the collar. Pull on the nozzle to make sure it is secured.

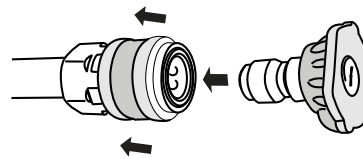

5. Mount the spray gun in the gun holders.

6. Connect the high-pressure hose to the high pressure outlet on the pump. DO NOT over-tighten.

NOTICE

Be careful to avoid cross-threading, which can cause the hose to leak during use.

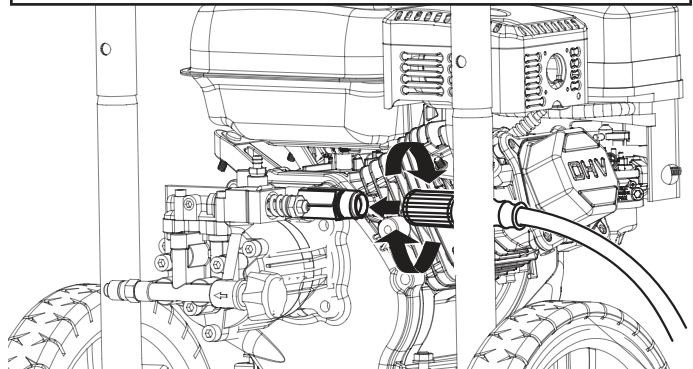

ASSEMBLY

INITIAL OIL FILL

NOTICE

THIS UNIT HAS BEEN SHIPPED WITHOUT OIL. Do not attempt to crank or start engine before it has been properly serviced with recommended oil. Failure to add engine oil before starting will result in serious engine damage.

NOTICE

Use of 2-stroke/cycle oil or other unapproved oil types can cause severe engine damage that is not covered under warranty.

The included, recommended oil type for typical use is 10W-30 engine oil. If running the pressure washer in extreme temperatures, refer to the following chart.

Recommended Engine Oil Type									
		10W-30							
	5W-30					10W-40			
	5W-30 Synthetic								
°F	-20	0	20	40	60	80	100	120	
°C	-28.9	-17.8	-6.7	4.4	15.6	26.7	37.8	48.9	
	Ambient temperature								

1. On a level surface, remove the oil dipstick.

Note: There is an oil dipstick/filler neck on both sides of the unit. Either can be used to check or add oil.

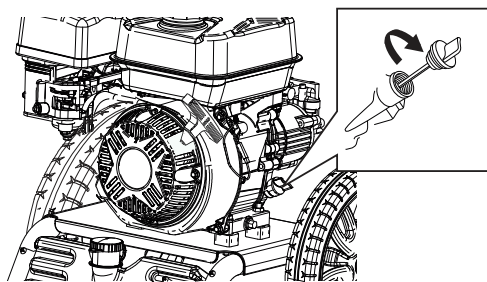

2. Using the supplied oil and funnel tip, add oil into oil filler neck.

Note: As residual oil from the factory may remain in the engine, add the oil incrementally to prevent overfilling the engine. See Engine Oil Level Check in the Maintenance section.

3. Replace the oil dipstick and hand-tighten.

FUEL

⚠ WARNING

Fire and explosion hazard. Never use a gasoline container, gasoline tank, or any other fuel item that is broken, cut, torn or damaged.

⚠ DANGER

Fire and explosion hazard. Do not overfill fuel tank. Fill only to the bottom of the filler neck. Overfilling may cause fuel to spill onto engine causing a fire or explosion hazard.

⚠ DANGER

Fire and explosion hazard. Never refuel the pressure washer while the engine is running. Always turn the engine off and allow the pressure washer to cool for two minutes before refueling.

NOTICE



Do not use E15 or E85 fuel in this product. Engine or equipment damage caused by stale fuel or the use of unapproved fuels (such as E15 or E85 ethanol blends) is not covered by warranty. Only use unleaded gasoline containing up to 10% ethanol.

FUEL REQUIREMENTS

- CLEAN, FRESH, unleaded gasoline, 87–93 octane.
- Up to 10% ethanol (gasohol) is acceptable (where available; non-ethanol fuel is recommended).
- DO NOT use E85 or E15.
- DO NOT use a gas oil mix.
- DO NOT modify the engine to run on alternate fuels.
- DO NOT fuel indoors.
- DO NOT create a spark or flame while fueling.

USING FUEL STABILIZER

Adding a fuel stabilizer (not included) extends the usable life of fuel and helps prevent deposits from forming that can clog the fuel system. Follow the manufacturer's instructions for use.

Always mix the correct amount of fuel stabilizer to gasoline in an approved gasoline container before fueling the pressure washer. Run the pressure washer for two minutes to allow the stabilizer to treat the entire fuel system.

ASSEMBLY

FILLING THE FUEL TANK

1. Turn the pressure washer OFF and allow to cool for a minimum of two minutes before fueling.
2. Place the pressure washer on level ground in a well ventilated area.
3. Clean area around fuel cap and remove the cap slowly.

NOTICE

Only fill the tank from an approved gasoline container. Make sure the gasoline container is internally clean and in good condition to prevent fuel system contamination.

4. Slowly add the recommended fuel. Do not overfill. Fill only to the top of the fuel screen filter visible in the filler neck.

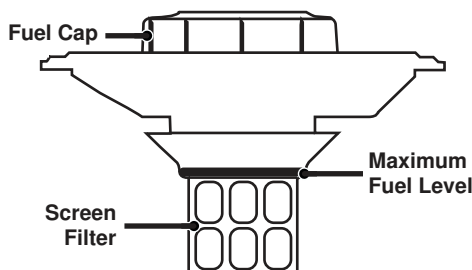

5. Install the fuel cap and tighten until a click is heard.

NOTICE

Fuel can damage paint and plastic. Use caution when filling the fuel tank. Damage caused by spilled fuel is not covered under warranty.

NOTICE

Clean the fuel screen filter of debris before and after each fueling. Remove the fuel screen filter by slightly compressing it while removing it from the fuel tank.

CONNECT THE GARDEN HOSE

NOTICE

Never connect your pressure washer to a hot water supply. Connecting your pressure washer to a hot water source will significantly reduce the life of the pump and will void the warranty.

The water supply must come from a pressurized water spicket. NEVER use hot water or water from pools, lakes, etc. Before connecting the garden hose to the pressure washer:

1. Run water through the hose for 30 seconds to clean any debris from the hose.
2. Inspect the screen and gasket in the pump water inlet. If the screen or gasket is damaged, do not use the pressure washer until replaced.
3. If the screen is dirty, clean it before connecting the garden hose to the pump.
4. Completely uncoil the garden hose or remove completely from reel to prevent kinks.

NOTICE

There must be a minimum of 10 ft. (3 m) of unrestricted hose between the pressure washer intake and the hose faucet or shut off valve (such as a "Y" shut off connector).

5. With the hose faucet turned OFF, attach the end of the garden hose to the pump water inlet. Tighten by hand.

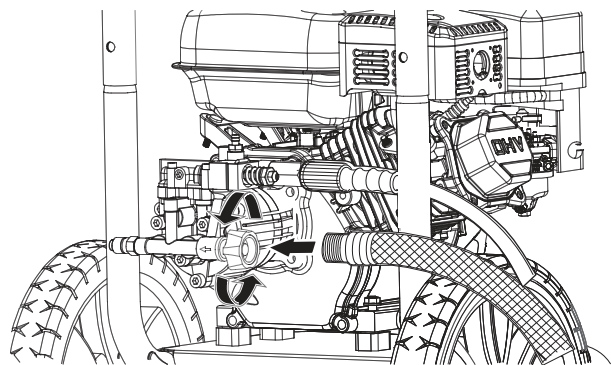

NOTICE

Do not run the pressure washer without the water supply connected and turned on, as this may damage the high pressure seals and decrease pump life. Completely unwind the hose from its reel or coil and make sure the hose is not being restricted by tires, rocks, or any other objects that may lessen or prevent water flow to the pressure washer

OPERATION

PRESSURE WASHER LOCATION

⚠ DANGER

Asphyxiation hazard. Never operate the pressure washer in an enclosed area. Engine exhaust contains carbon monoxide that can kill in minutes. Only operate the pressure washer outside and away from windows, doors and vents. Place the pressure washer in a well-ventilated area. DO NOT place the pressure washer near vents or intakes where exhaust fumes could be drawn into occupied or confined spaces. Carefully consider wind and air currents when positioning the pressure washer.

This pressure washer must have at least 5ft. (1.5m) of clearance from combustible material. Leave at least 3 ft. (0.91 m) of clearance on all sides of the pressure washer to allow for adequate cooling, maintenance, and servicing.

BEFORE STARTING THE ENGINE

Verify that:

- The pressure washer is placed in an appropriate location.
- The unit is on a dry, flat, and level surface.
- The engine is filled with oil.

STARTING THE ENGINE

⚠ WARNING

Always wear safety goggles or safety glasses with side shields, and as necessary a full face shield as well as full ear protection when operating this product.

NOTICE

Running the unit for more than one minute without spraying water causes heat to build up in the pump. In the event that the pump gets too hot, a thermal relief valve will open to release the hot water. Running the unit without spraying water can damage pump components and will void the warranty.

1. Turn the water supply ON.
2. Pull the trigger on the spray gun to purge all air from the pump and hose. This may take several minutes.
3. Do not start the engine until a steady stream of water is flowing from the nozzle.
4. Turn the engine switch to the ON position.

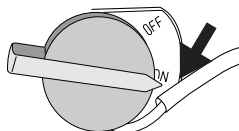

5. Turn the fuel valve to the ON position.

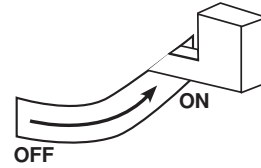

6. If the engine is cold, move the choke lever to the CHOKE position.

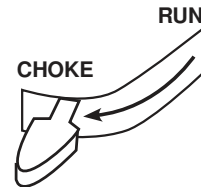

7. Pull the recoil handle slowly until resistance is felt and then pull rapidly.

Note: If the engine starts briefly and then shuts off, squeeze the trigger on the spray gun to relieve the pressure before trying to start the engine again.

8. Once the engine starts, move the choke lever to the RUN position. Allow the engine to warm up slightly before use.

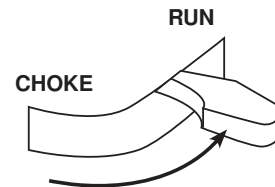

STOPPING THE PRESSURE WASHER

During normal operation, use the following steps to stop the pressure washer:

1. Engage the spray gun trigger lock in the safe position.
2. Move the engine OFF/ON switch to the OFF position.

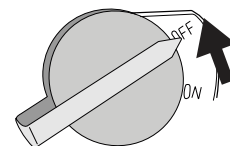

3. Close the fuel valve.

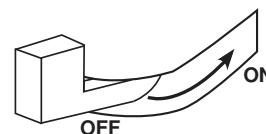

4. Turn the water supply OFF.
5. Disengage the trigger lock and depress the trigger for 15 seconds to depressurize the system.

OPERATION

- Disconnect the garden hose from the water inlet.
- Complete all steps in the AFTER EACH USE section of this manual.

DURING AN EMERGENCY

If there is an emergency and the pressure washer must be stopped quickly, push the engine control switch to OFF position immediately.

SELECTING NOZZLES

The quick-connect coupler on the spray lance allows changing between nozzles while the pressure washer is running.

CHANGING THE NOZZLE

Pull back the quick-connect collar at the end of the spray lance. Insert the nozzle then release the collar. Pull on the nozzle to make sure it is secured.

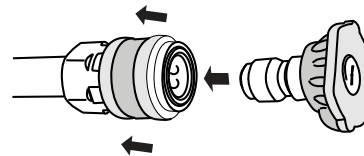

SPRAYING TIPS

For most cleaning, keep nozzle 8 - 24 in. (20 - 61 cm) away from cleaning surface.

- Damage may occur to the cleaning surface if you spray too close, especially with high-pressure nozzles.
- When beginning to spray, start farther away and move closer to avoid damage to the surface.
- To prevent damage to tires, allow at least 6 in. (15 cm) between a tire and the nozzle.

⚠ WARNING

Always engage the trigger lock before changing a nozzle.

NOTICE

Only use the nozzles that were supplied with the pressure washers. Using any other nozzles can affect performance and may void the warranty. For replacement nozzles call (855) 944-3571.

NOZZLE SELECTION					
	HIGH PRESSURE WASH				LOW PRESSURE WASH
	RED 0°	YELLOW 15°	GREEN 25°	WHITE 40°	SOAP
Concrete, Brick, Masonry	!	!	✓	✓	✓
Siding, Gutters, Home	X	!	!	✓	✓
Fencing, Deck, Patio	X	!	!	✓	✓
Lawn and Garden Equipment, Boats, RVs	X	!	!	✓	✓
✓ Recommended nozzle ! Use with caution X Do not use					

OPERATION

DETERGENT USE

The use of detergents can dramatically reduce cleaning time and assist in the removal of difficult stains. Many detergents are customized for pressure washer use for specific cleaning tasks. When spraying detergent, the detergent will be diluted 1:12. Approximately 621 ml (21 oz.) of detergent will be consumed from the tank for every minute sprayed.

NOTICE

Only use detergents designed for pressure washers. Pressure washer detergents are as thick as water. Using thicker detergents, like dish soap, will clog the chemical injection system. Do not use household detergents, acids, alkalines, bleaches, solvents, flammable material, or industrial grade solutions, which can damage the pump or cause property damage.

Prepare cleaning solution as instructed on the solution bottle. Always test in an inconspicuous area before beginning. You can effectively clean surfaces by combining the chemical action of detergents with high pressure rinses. On vertical surfaces, apply the detergent starting at the bottom and work your way upward. This method prevents the detergent from sliding down and causing streaks. Begin high pressure rinsing at the bottom and work your way upward. On particularly tough stains, use a brush in combination with detergents and high pressure rinsing.

1. Fill the detergent tank with cleaning solution.
2. Install the detergent nozzle (black) in the spray lance. Detergent will only be drawn through the pump when the black detergent nozzle is attached to the end of the spray lance.
3. Make sure the water supply is ON. Start the engine. Pull the trigger to spray the detergent solution.

NOTICE

NEVER use bleach in detergent tank. It will damage the pump and void the warranty.

4. Use long, even overlapping strokes to apply soap. Allow 3 – 5 minutes for the soap to soak in before rinsing. Do not allow the soap to dry on the surface before rinsing. Reapply soap if necessary to maintain a wet surface for the soap to soak in.

DETERGENT SYSTEM FLUSH

The detergent suction system can be flushed by removing the suction tube from the detergent tank and placing the tube in a fresh bucket of water. Only perform a system flush when the detergent tank is empty.

1. With the water supply ON, the black nozzle connected to the spray gun lance, and the engine running, disconnect the suction tube from the bottom of the detergent tank.
2. Place the suction tube in a clean bucket of water, disengage the trigger lock, then depress the spray gun trigger to flush the system.
3. Engage the trigger lock then reinstall the suction tube on the detergent tank.

AFTER EACH USE

1. Lock the spray gun trigger.
2. Turn the engine OFF, then turn the water supply OFF.
3. Disengage the trigger lock and depress the trigger for 15 seconds to depressurize the system.
4. Let the pressure washer cool down.
5. Disconnect the high-pressure hose and water inlet hose.
6. Drain the hoses, spray gun, and nozzle extension.
7. Engage the trigger lock on the spray gun.
8. Wipe off all remaining water with a clean, dry rag.
9. While the pressure washer is turned off, pull the recoil handle 5 - 6 times. This should remove most of the remaining liquid inside the pump.
10. Store the pressure washer in a clean, dry place.

TRANSPORTING

⚠ CAUTION

Weight hazard. Always have assistance when lifting the pressure washer.

- Allow the pressure washer to cool a minimum of 30 minutes before transporting.
- Only use the pressure washer's fixed frame to lift the unit or attach any load restraints such as ropes or tie-down straps. Do not attempt to lift or secure the pressure washer by holding onto any of its other components.
- Keep the unit level during transport to minimize the possibility of fuel leakage or, if possible, drain the fuel or run the engine until the fuel tank is empty before transport.
- The pressure washer wheels are only intended for hand transport. The wheels are not suitable for towing the pressure washer either on or off-road.

MAINTENANCE

⚠ CAUTION

Fire hazard. Do not up-end the pressure washer or place it on its side. Fuel or oil can leak and damage to the pressure washer may occur.

MAINTENANCE SCHEDULE

⚠ WARNING

Disconnect the spark plug boot from the spark plug when performing maintenance on the pressure washer.

Regular maintenance will improve performance and extend the service life of the pressure washer. Follow the hourly or calendar intervals, whichever occurs first. More frequent service is required when operating in adverse conditions as noted below.

Before Each Use

- Check engine oil
- Check water inlet screen and gasket
- Clean around air intake and muffler

After First 5 Hours

- Change engine oil

After 50 Hours or Every Season

- Clean air filter
- Change engine oil if operating under heavy load or in hot environments
- Clean spark arrestor

After 100 Hours or Every Season

- Inspect/clean spark arrestor
- Inspect/clean spark plug
- Inspect/adjust valve clearance*

After 300 Hours

- Replace spark plug
- Replace air filter

* Recommend service to be performed by authorized Westinghouse service dealer.

CLEANING THE PRESSURE WASHER

⚠ CAUTION

DO NOT spray the pressure washer with water. Water can contaminate the fuel system and can enter the engine through the cooling slots and damage the engine.

1. Use a damp cloth to clean exterior surfaces of the pressure washer.
2. Use a soft bristle brush to remove dirt and oil.
3. Use an air compressor (25 PSI) to clear dirt and debris from the pressure washer.

4. Inspect all air vents and cooling slots to ensure that they are clean and unobstructed.

CLEANING SPRAY NOZZLES

Detach the nozzle from the spray lance. Use the included nozzle cleaning tool to loosen any particles in the nozzle. Flush with water.

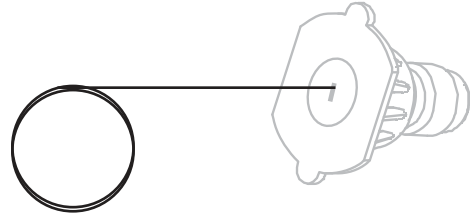

AIR FILTER MAINTENANCE

⚠ WARNING

Fire hazard. Never use gasoline or other flammable solvents to clean the air filter.

The air filter must be cleaned after every 50 hours of use or six months (frequency should be increased if the pressure washer is operated in a dusty environment).

1. Place the pressure washer on a level surface and allow the engine to cool for several minutes.
2. Use your fingers to unscrew the thumb screw on top of the air filter assembly. Remove the wing nut, then remove the air filter.

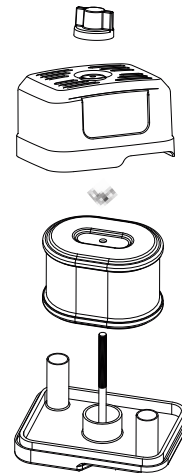

3. Use compressed air to clean the air filter from the inside out.

Note: The outer foam air filter element is not intended to be removed. If torn, replace the air filter.

MAINTENANCE

ENGINE OIL LEVEL CHECK

⚠ CAUTION

Avoid skin contact with engine oil. Wear protective clothing and equipment. Wash all exposed skin with soap and water.

NOTICE

Always use the specified engine oil. Failure to use the specified engine oil can cause accelerated wear and/or shorten the life of the engine.

When using the pressure washer under extreme, dirty, dusty conditions or in extremely hot weather, change the oil more frequently.

Ambient air temperature will affect engine oil performance. Change the type of engine oil used based on weather conditions.

Recommended Engine Oil Type								
		10W-30						
5W-30					10W-40			
5W-30 Synthetic								
°F	-20	0	20	40	60	80	100	120
°C	-28.9	-17.8	-6.7	4.4	15.6	26.7	37.8	48.9
Ambient temperature								

Check the engine oil level before each use.

1. Place the pressure washer on a level surface and allow the engine to cool for several minutes.
 2. With a damp rag, clean around the oil dipstick.
- Note:** There is an oil dipstick/filler neck on both sides of the unit. Either can be used to check or add oil.
3. Remove the oil dipstick and wipe the dipstick clean.

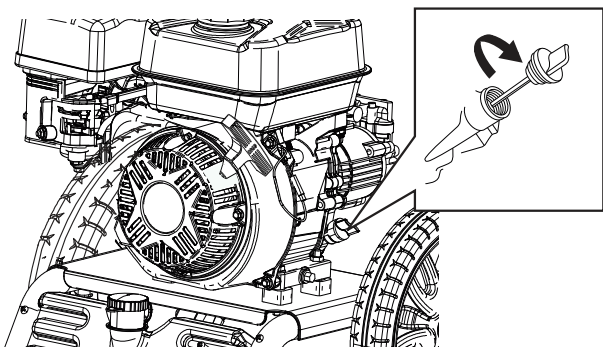

4. Screw the dipstick fully into the oil filler neck. Remove the dipstick and verify that the oil level is within safe operating range.

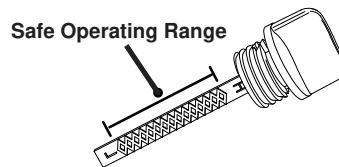

5. If low, add recommended engine oil incrementally and recheck until the level is between the L and H marks on the dipstick. DO NOT overfill. If over the full mark (H) on the dipstick, drain the oil to reduce the oil level to the full mark.
6. Replace the oil dipstick and hand-tighten.

ENGINE OIL CHANGE

When using the pressure washer under extreme, dirty, dusty conditions or in extremely hot weather, change the oil more frequently. Change the oil while the engine is still warm from operation.

1. Place the pressure washer on a level surface and allow the engine to cool for several minutes.
2. With a damp rag, clean around the oil dipstick. Remove the dipstick and wipe clean.
3. Place an oil pan (or suitable container) under the oil drain bolt.
4. Using a 10mm wrench, remove the oil drain bolt and allow the oil to drain.

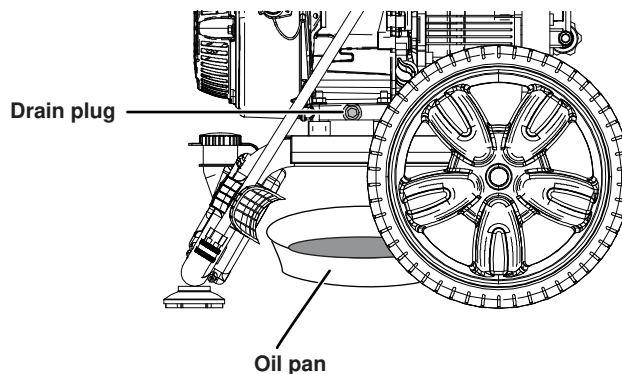

5. Install the oil drain bolt and tighten securely.
6. Slowly pour oil into the oil filler neck until the level is between the L and H marks on the dipstick. Stop frequently to check the oil level. DO NOT overfill.

Maximum oil capacity: 20 Oz. (0.6 Liter)

7. Install the oil dipstick and hand-tighten.

MAINTENANCE

NOTICE

Do not pollute. Follow the guidelines of the EPA or other governmental agencies for proper disposal of hazardous materials. Consult local authorities or reclamation facility.

SPARK PLUG MAINTENANCE

Inspect and clean the spark plug after every 100 hours of use or six months. Replace the spark plug after 300 hours of use or every year.

1. Place the pressure washer on a level surface and allow the engine to cool.
2. Remove the spark plug boot by firmly pulling the spark plug boot directly away from the engine.

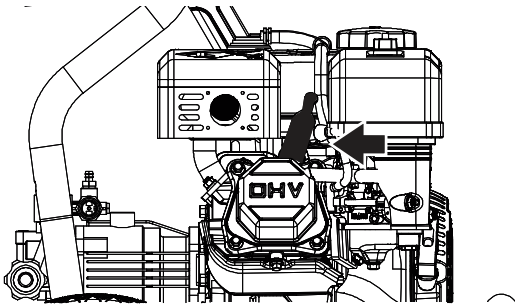

3. Clean the area around the spark plug.
4. Remove the spark plug with the included spark plug socket wrench.

NOTICE

Never apply any side load or move the spark plug laterally when removing the spark plug.

5. Inspect the spark plug. Replace if electrodes are pitted, burned, or the insulator is cracked. Only use a recommended replacement plug.

Recommended Spark Plug Replacement

Westinghouse Model Number	Torch	NGK	Champion	Autolite
WPX3400	F7TC	BP7ES	332	62

6. Measure the spark plug electrode gap with a wire-type feeler gauge. If necessary, correct the gap by carefully bending the side electrode.

Spark plug gap: 0.024 – 0.032 in. (0.60 – 0.80 mm)

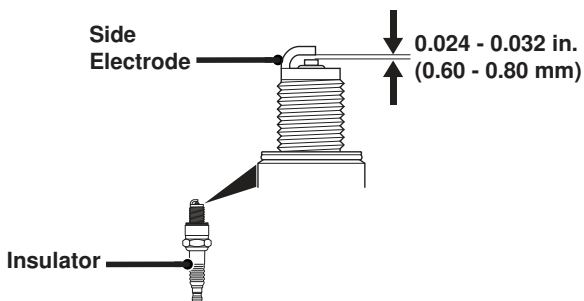

7. Carefully install the spark plug finger tight, then tighten as additional 3/8 to 1/2 turn with the spark plug wrench.
8. Attach the spark plug boot.

SPARK ARRESTOR SERVICE

Allow the muffler to cool completely before servicing the spark arrestor. Check and clean the spark arrestor after every 100 hours of use or every season. Failure to clean the spark arrestor will result in degraded engine performance.

1. Place the pressure washer on a level surface.
2. Carefully remove the carbon deposits from the spark arrestor screen with a wire brush. The spark arrestor must be free of breaks and tears. Replace the spark arrestor if damaged.

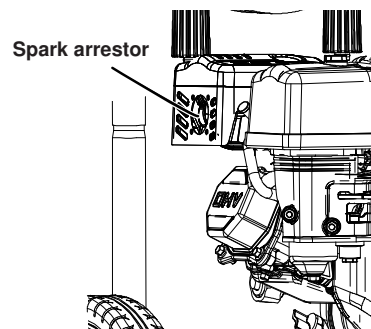

MAINTENANCE

STORAGE

Proper storage preparation is required for trouble-free operation and pressure washer longevity.

NOTICE

Gasoline stored for as little as 30 days can deteriorate, causing gum, varnish, and corrosive buildup in fuel lines, fuel passages, and the engine. This corrosive buildup restricts the flow of fuel, which can prevent the engine from starting after a prolonged storage period. The use of fuel stabilizer significantly increases the storage life of gasoline. Full-time use of fuel stabilizer is recommended. Follow the manufacturer's instructions for use.

⚠ WARNING

Never store a pressure washer with fuel in the tank indoors or in a poorly ventilated area where the fumes can come in contact with an ignition source such as a pilot light of a stove, water heater, clothes dryer, or any other gas appliance, or a spark from an electric appliance.

STORAGE TIME	RECOMMENDED PROCEDURE
Less than 1 month	No service required.
2 to 6 months	Fill with fresh gasoline and add gasoline stabilizer. Drain the carburetor float bowl.
6 months or longer	Drain the fuel tank and carburetor float bowl.

STORED FOR LESS THAN 30 DAYS

- Allow the pressure washer to cool a minimum of 30 minutes before storage.
- Wipe the pressure washer with a moist cloth. Clean any debris from the muffler cooling vents.
- Store the pressure washer in a well-ventilated, clean, dry location away from sparks, open flames, pilot lights, heat, and other sources of ignition such as areas with a spark-producing electric motor or where power tools are operated. Store in an area out of direct sunlight.
- Do not store the pressure washer or gasoline near furnaces, water heaters, or any other appliances that produce heat or have automatic ignitions.

STORED FOR OVER 30 DAYS

Even properly stabilized fuel can leave residue and cause corrosion if left long term. If storing the pressure washer for two to six months, drain the float bowl to prevent gum and varnish buildup in the carburetor.

WINTER STORAGE

Make sure the pressure washer hose is free of all water before storing for winter. In order to prevent corrosion and keep the water pump from freezing you will need to add RV (non-toxic) antifreeze or similar pump-protection specifically made for pressure washers. Follow the manufacturer's instructions for use.

DRAINING THE FLOAT BOWL

1. Turn the fuel tank valve to the OFF position.
2. Locate the drain screw on the bottom of the carburetor float bowl.

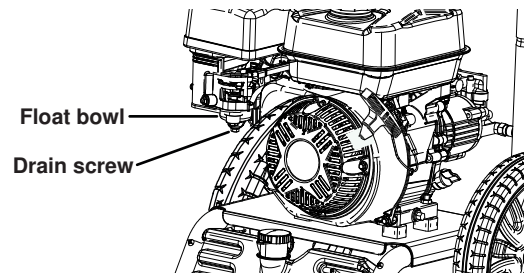

3. Place an appropriate gasoline container under the drain screw to catch the drained fuel.
4. Loosen the float bowl drain screw and allow the fuel to drain. Tighten the float bowl drain screw.

DRAINING THE FUEL TANK

If storing the pressure washer for longer than six months, drain the fuel tank to prevent fuel separation, deterioration, and deposits in the fuel system.

1. Drain the float bowl.
2. Unscrew the fuel tank cap. Remove the fuel screen filter by slightly compressing it while removing it from the tank.
3. Using a commercially available gasoline hand pump (not included), siphon the gasoline from the fuel tank into an approved gasoline container. DO NOT use an electric pump.
4. Reinstall the fuel screen filter and the fuel tank cap.
5. Push the battery switch to the OFF position.
6. Disconnect the battery quick-connect plugs.
7. Remove the spark plug.

MAINTENANCE

- Put a teaspoon of engine oil into the cylinder and pull the recoil handle until resistance is felt. At this position the piston is coming up on its compression stroke and both valves are closed. Storing the engine in this position will help prevent internal corrosion. Return the recoil handle gently.
- Reinstall the spark plug. Leave the spark plug boot disconnected to prevent accidental starting.

- Turn the rocker arm pivot to obtain the specified clearance. Hold the rocker arm pivot and re-tighten the pivot adjusting nut to the specified torque.

Torque: 106 inch-pound (12 N•m)

- Perform this procedure for the other valve.
- Install the gasket, rocker arm cover, and spark plug.

VALVE CLEARANCE

NOTICE

Checking and adjusting valve clearance must be done when the engine is cold.

- Remove the rocker arm cover and carefully remove the gasket. If the gasket is torn or damaged, it must be replaced.
- Remove the spark plug so the engine can be rotated more easily.
- Rotate the engine to top dead center (TDC) by pulling the recoil handle slowly. Looking through the spark plug hole, the piston should be at the top (both valves are closed).
- Both the rocker arms should be loose at TDC on the compression stroke. If they are not, rotate the engine 360°.
- Insert a feeler gauge between the rocker arm and the valve stem to measure valve clearance.

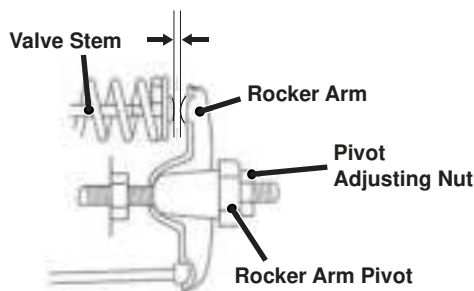

	Intake Valve	Exhaust Valve
Valve Clearance	0.0031 – 0.0047 in (0.08 – 0.12 mm)	0.0051 – 0.0067 in (0.13 – 0.17 mm)
Torque	8-12 N•m	8-12 N•m

- If an adjustment is necessary, hold the rocker arm pivot and loosen the pivot adjusting nut.

TROUBLESHOOTING

TROUBLESHOOTING

PROBLEM	POSSIBLE CAUSE	CORRECTION
Engine will not start.	Fuel valve in OFF position.	Turn fuel valve to ON position.
	No fuel.	Add fuel.
	Choke in wrong position.	Adjust choke.
	Spark plug wire loose.	Attach spark plug boot.
	Faulty spark plug.	Replace spark plug.
	Stale fuel or water in fuel.	Drain fuel and replace with fresh fuel.
	Dirty air filter.	Clean or replace air filter.
	Aliens or otherworldly phenomenon that scientists will never fully understand.	Contact Westinghouse customer service toll-free at 1 (855) 944-3571.
Engine suddenly stops.	Out of fuel.	Add fuel.
	Low oil.	Check oil and add if low.
Engine runs erratically.	Choke in wrong position.	Adjust choke.
	Low oil.	Check oil and add if low.
	Stale fuel or water in fuel.	Drain fuel and replace with fresh fuel.
	Faulty spark plug.	Replace spark plug.
Unit does not reach high pressure.	Water supply restricted.	Check hoses for leaks, blockages, kinks.
	Garden hose too small.	Use 5/8 in. (0.025 mm) hose or larger.
	Not enough inlet water.	Turn garden hose water supply fully ON. Check hoses for leaks, blockages, kinks.
Spray pressure varies.	Poor inlet water supply.	Remove garden hose, clean filter.
	Garden hose inlet filter is clogged.	Remove garden hose, clean filter.
	Spray nozzle is restricted.	Remove particles with nozzle cleaning tool.
	Air ingress to pump.	Check all hoses and fittings for secure connections. With water supply ON, turn engine OFF and purge pump of air by depressing trigger until a steady stream of water flows.
Low pressure detergent wash not working.	Wrong nozzle installed on spray lance.	Detergent only works with black (low pressure) nozzle installed. Install black nozzle. If missing, replace.
	Detergent is too thick.	Use detergent made specifically for pressure washer use.
	Detergent hose is not connected to the pump.	Check hose connections.
	Spray nozzle is obstructed.	Clean nozzle of debris.
	Detergent hose is clogged.	Remove detergent hose and clean. Replace.
	Blockage inside pump detergent valve.	Quickly depress and release spray gun trigger 4-5 times to clear the detergent valve.
Garden hose connection leaks.	Loose fittings.	Tighten fittings.
	Missing/worn rubber washer.	Check hose and pump water inlet washers. Replace if missing/worn.
Spray gun lance leaks.	Loose fittings.	Check for worn O-rings or loose connections.
	Missing/worn rubber washers.	Remove spray lance and/or high pressure hose. Check and replace washers if necessary.
Cannot pull recoil starter handle.	Pump pressure.	Depress spray gun trigger to relieve pressure.

EXPLODED VIEW

EXPLODED VIEW A

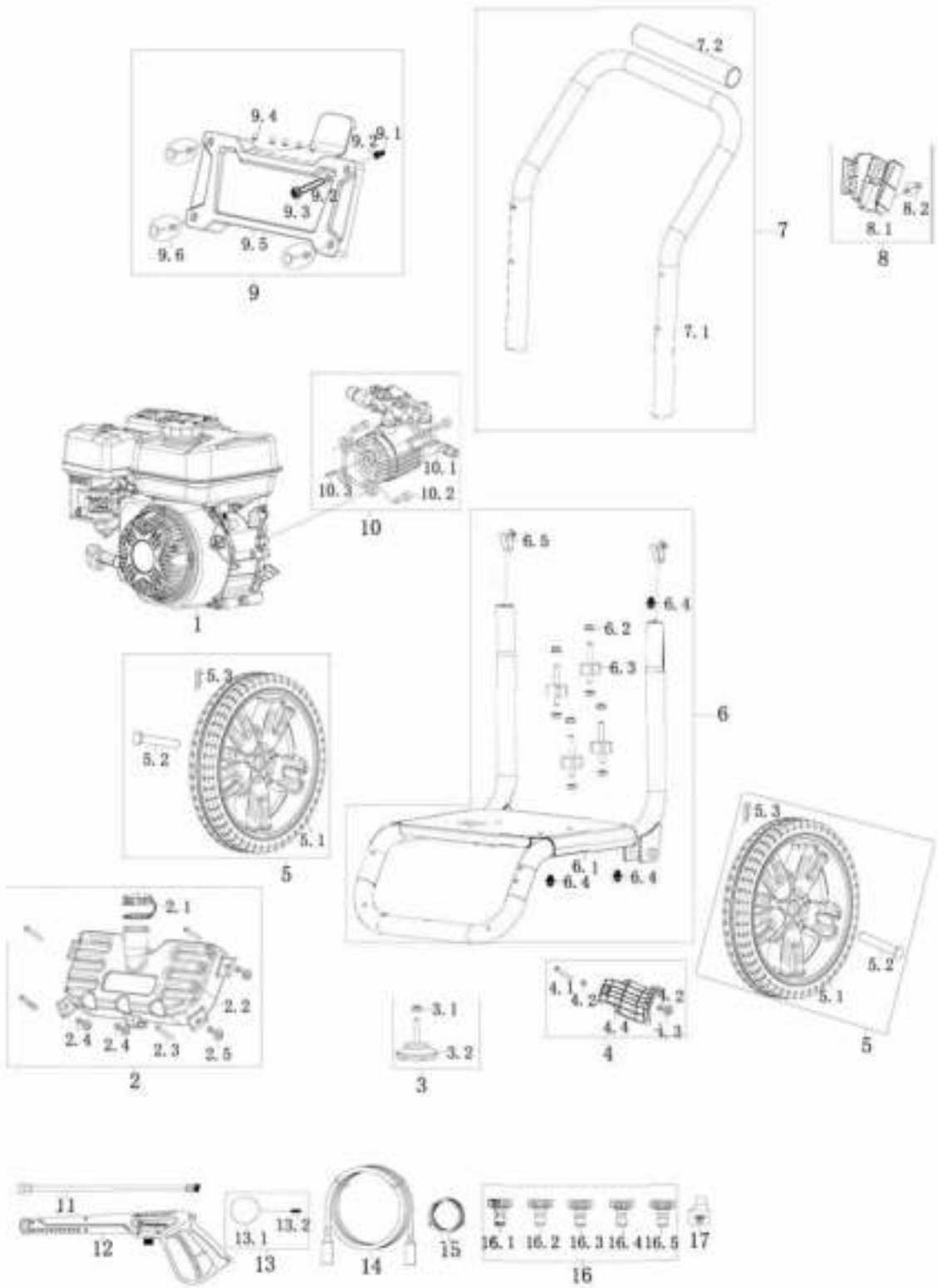

EXPLODED VIEW

EXPLODED VIEW A PARTS LIST

NO.	PART#	DESCRIPTION
1	1148212110043	ENGINE
2	80100003	DETERGENT KIT ASSEMBLY
	2.1	SOAP TANK CAP
	2.2	SOAP TANK
	2.3	BOLT M6*45
	2.4	FLAT WASHER
	2.5	NUT M6
3	80210003	FOOT PADS KIT ASSEMBLY
	3.1	NUT M8
	3.2	MOUNTING FOOT
4	80190002	LOWER GUN HOLDER KIT ASSEMBLY
	4.1	BOLT M6*45
	4.2	FLAT WASHER
	4.3	NUT M6
	4.4	LOWER GUN HOLDER
5	80090004	WHEEL KIT ASSEMBLY
	5.1	WHEEL
	5.2	AXLE
	5.3	COTTER PIN
6	80020003	FRAME BASE KIT ASSEMBLY
	6.1	FRAME BOTTOM BASE
	6.2	NUT M8
	6.3	VIBRATION PAD
	6.4	CABLE CLIP
	6.5	SPRING CLIP
7	80030006	HANDLE KIT ASSEMBLY
	7.1	FRAME HANDLE
	7.2	HANDLE PAD

NO.	PART#	DESCRIPTION
8	80140001	UPPER GUN HOLDER KIT ASSEMBLY
	8.1	UPPER GUN HOLDER
	8.2	PLASTIC EXPANSION SCREW
9	80110005	CONTROL PANEL KIT ASSEMBLY
	9.1	NUT M6
	9.2	FLAT WASHER 6x 12
	9.3	BOLT M6*50
	9.4	NOZZLE SLEEVE
	9.5	PANEL
	9.6	PLASTIC EXPANSION SCREW
10	80400003	WATER PUMP KIT ASSEMBLY
	10.1	WATER PUMP ASSEMBLY
	10.2	BOLT M8*20
	10.3	CRANKSHAFT FLAT KEY
11	817110	SPRAY ROD COMPONENTS
12	817088-219	SPRAY GUN
13	80610002	NOZZLE CLEANER KIT ASSEMBLY
	13.1	NOZZLE CLEANING TOOL
	13.2	NOZZLE CLEANING TOOL SHEATH
14	811557	HIGH PRESSURE HOSE
15	811002	DETERGENT SUCTION HOSE
16	80600002	NOZZLE KIT ASSEMBLY
	16.1	(0° RED) NOZZLE
	16.2	(15° YELLOW) NOZZLE
	16.3	(25° GREEN) NOZZLE
	16.4	(60° WHITE) NOZZLE
	16.5	DETERGENT NOZZLE
17	99647	OIL BOTTLE

EXPLODED VIEW

EXPLODED VIEW B

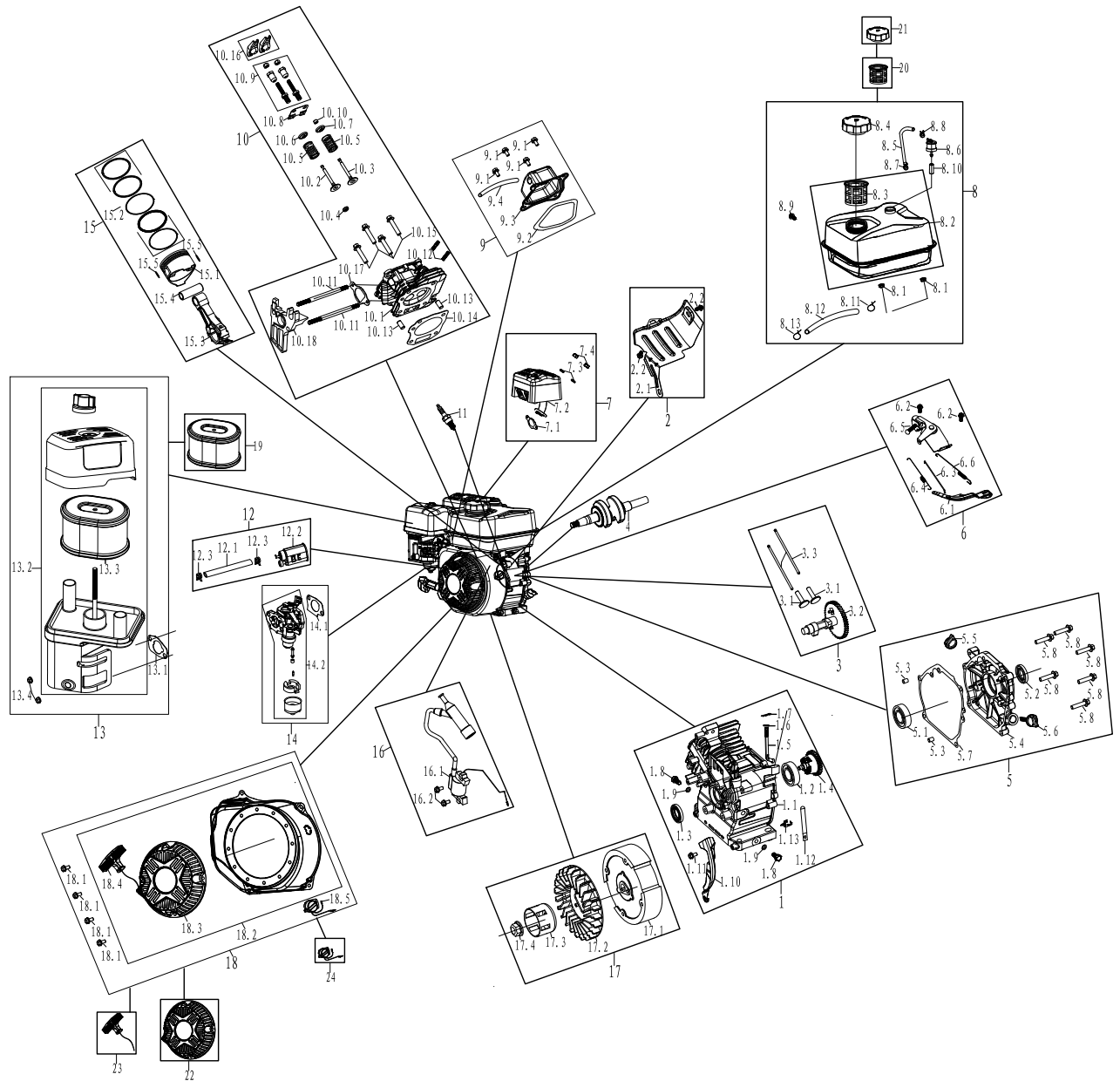

EXPLODED VIEW B PARTS LIST

NO.	PART#	DESCRIPTION
1	50120027	CRANKCASE KIT ASSEMBLY
	1.1	CRANKCASE
	1.2	BEARING
	1.3	CRANKCASE OIL SEAL
	1.4	GOVERNOR ASSEMBLY
	1.5	SHAFT, GOVERNOR ARM
	1.6	WASHER, GOVERNOR ARM SHAFT
	1.7	LOCK PIN
	1.8	OIL DRAIN BOLT
	1.9	OIL DRAIN BOLT WASHER
	1.10	SHROUD WELDING ASSEMBLY
	1.11	BOLT M6*20
	1.12	METAL CLAMP
	1.13	CLIP
2	50130011	SHROUD KIT ASSEMBLY
	2.1	SHROUD

NO.	PART#	DESCRIPTION
3	50150004	CAMSHAFT KIT ASSEMBLY
	3.1	VALVE LIFTER
	3.2	CAMSHAFT ASSEMBLY
	3.3	VALVE PUSH ROD
4	240346	CRANKSHAFT ASSEMBLY
5	50200030	CRANKCASE COVER KIT ASSEMBLY
	5.1	BEARING
	5.2	CRANKCASE OIL SEAL
	5.3	CRANKCASE DOWEL PIN
	5.4	CRANKCASE COVER
	5.5	OIL PLUG
	5.6	DIPSTICK ASSEMBLY
	5.7	CRANKCASE GASKET
5.8	BOLT M8*30	

EXPLODED VIEW

EXPLODED VIEW B PARTS LIST CONTINUED

NO.	PART#	DESCRIPTION
6	50060023	SPEED CONTROLLER KIT ASSEMBLY
	6.1	GOVERNOR ARM
	6.2	BOLT M6*12
	6.3	THROTTLE LEVER
	6.4	SLIGHT SPEED REGULATING SPRING C
	6.5	SPEED CONTROLLER
	6.6	SPEED REGULATING SPRING B
7	50240019	MUFFLER EXHAUST KIT ASSEMBLY
	7.1	EXHAUST GASKET
	7.2	MUFFLER ASSEMBLY
	7.3	SPRING WASHER
	7.4	NUT M8
8	50250033	FUEL TANK KIT ASSEMBLY
	8.1	NUT M6
	8.2	FUEL TANK ASSEMBLY
	8.3	STRAINER
	8.4	FUEL TANK CAP ASSEMBLY
	8.5	CONNECTING PIPE OF FUEL TANK AND AIR CLEANER
	8.6	ONE WAY VALVE ASSEMBLY
	8.7	FUEL LINE CLAMP
	8.8	FUEL LINE CLAMP
	8.9	BOLT M6*28
	8.10	VENT PIPE PROTECTIVE SLEEVE
	8.11	FUEL LINE CLAMP
	8.12	FUEL LINE
	8.13	FUEL LINE CLAMP
9	50010025	CYLINDER HEAD COVER KIT ASSEMBLY
	9.1	BOLT M6*12
	9.2	CYLINDER HEAD COVER GASKET
	9.3	CYLINDER HEAD COVER
	9.4	BREATHER TUBE
10	50020040	CYLINDER HEAD KIT ASSEMBLY
	10.1	CYLINDER HEAD
	10.2	INTAKE VALVE
	10.3	EXHAUST VALVE
	10.4	INTAKE VALVE SPRING
	10.5	VALVE SPRINGS
	10.6	INTAKE VALVE SPRING SEAT
	10.7	EXHAUST VALVE SPRING SEAT
	10.8	PUSH ROD GUIDE PLATE ASSEMBLY
	10.9	ROCKER ARM ADJSUTER
	10.10	TOP CAP
	10.11	AIR INLET STUD BOLT
	10.12	AIR OUTLET STUD BOLT
	10.13	CYLINDER HEAD LOCATING PIN
	10.14	CYLINDER HEAD GASKET
	10.15	BOLT M8*60
	10.16	ROCKER ARM
	10.17	INTAKE GASKET

NO.	PART#	DESCRIPTION
	10.18	CARBURETOR CONNECTION BLOCK
11	97108	SPARK PLUG
12	50610001	CARBON CANNISTER KIT ASSEMBLY
	12.1	CARBON CANNISTER AND AIR FILTER CONNECTING PIPE
	12.2	CARBON CANNISTER ASSEMBLY
	12.3	FUEL LINE CLAMP
13	50030049	AIR CLEANER KIT ASSEMBLY
	13.1	STEEL GASKET
	13.2	AIR CLEANER ASSEMBLY
	13.3	AIR CLEANER ELEMENT
	13.4	NUT M6
14	50040072	CARBURETOR KIT ASSEMBLY
	14.1	CARBURETOR GASKET
	14.2	MUFFLER KIT ASSEMBLY
15	50050013	PISTON RING KIT ASSEMBLY
	15.1	PISTON
	15.2	PISTON RING ASSEMBLY
	15.3	CONNECTING ROD ASSMEBLY
	15.4	PISTON PIN
	15.5	PISTON PIN RETAINER
16	50100018	IGNITION COIL KIT ASSEMBLY
	16.1	IGNITION COIL ASSEMBLY
	16.2	BOLT M6*25
17	50180007	FLYWHEEL KIT ASSEMBLY
	17.1	FLYWHEEL COMPONENTS
	17.2	IMPELLER
	17.3	STARTER PULLY
	17.4	IMPELLER NUT M14*1.5
18	50090052	RECOIL KIT ASSEMBLY
	18.1	BOLT M6*12
	18.2	RECOIL ASSEMBLY
	18.3	RECOIL
	18.4	PULL HANDLE
	18.5	SWITCH ASSEMBLY
19	5322	AIR CLEANER ELEMENT
20	246903	STRAINER
21	519201	FUEL TANK CAP ASSEMBLY
22	5980-116	RECOIL
23	5914-243	PULL HANDLE
24	245205-243	SWITCH ASSEMBLY