

VEVOR[®]

TOUGH TOOLS, HALF PRICE

Technical Support and E-Warranty Certificate

www.vevor.com/support

COMMERCIAL DEHUMIDIFIER

**MODEL: OL60D-BD063D /
OL80-BD065D / OL100-BD066D**

We continue to be committed to provide you tools with competitive price. "Save Half", "Half Price" or any other similar expressions used by us only represents an estimate of savings you might benefit from buying certain tools with us compared to the major top brands and does not necessarily mean to cover all categories of tools offered by us. You are kindly reminded to verify carefully when you are placing an order with us if you are actually saving half in comparison with the top major brands.

VEVOR[®]

TOUGH TOOLS, HALF PRICE

COMMERCIAL
DEHUMIDIFIER

MODEL: OL60D-BD063D / OL80-BD065D / OL100-BD066D

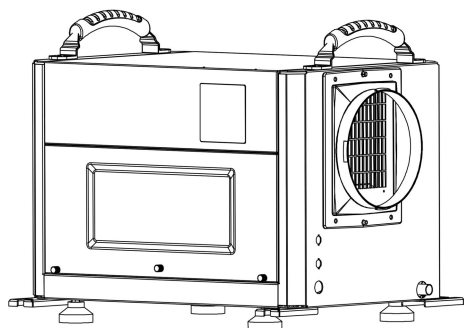

OL60D-BD063D

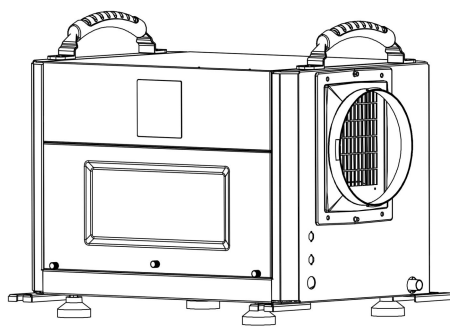

OL80-BD065D / OL100-BD066D

NEED HELP? CONTACT US!

Have product questions? Need technical support? Please feel free to contact us:













Technical Support and E-Warranty Certificate
www.vevor.com/support

This is the original instruction, please read all manual instructions carefully before operating. VEVOR reserves a clear interpretation of our user manual. The appearance of the product shall be subject to the product you received. Please forgive us that we won't inform you again if there are any technology or software updates on our product.

PRODUCT PAREMETERS

Model	OL60D-BD063D	OL80-BD065D	OL100-BD066D
Dehumidify Capacity(80°F,60% RH)	60Pint/Day	80Pint/Day	100Pint/Day
Power Supply	110-120V 60Hz	110- 120V 60Hz	110-120V 60Hz
Air Flow	210CFM	237CFM	237CFM
Rated Input Current	5.0A	6.6A	7.9A
Maxi Input Current	5.9A	8.3A	9.8A
Refrigerant/Charge	R32/5.65oz	R32/6.35oz	R32/9.18oz
Noise	≤60dB(A)	≤60dB(A)	≤60dB(A)
Low Side Pressure	260 Psi	260 Psi	260 Psi
High Side Pressure	550 Psi	550 Psi	550 Psi
BCSC	15A	15A	15A
Compressor Input	RLA:3.25A/LRA:20A	RLA:6.7A/LRA:35A	RLA:6.7A/LRA:35A
Fan Motor Power	0.75A/0.1 15HP	0.92A/0.133HP	0.92A/0.133HP

PACKING LIST

NO	Part Name	QTY	PICTURE
1	Dust Adapter	1	
2	External Pump Full Water Signal Input Cable	1	
3	Control Panel External Connection Cable	1	
4	Control Panel Hole Cover	1	
5	Drain Pipe	1	
6	Adjustable Feet	4	
7	Ceiling Mount Gasket	4	
8	Flat Washer	12	
9	Spring Washers	12	
10	Hexagon Head Screw	12	
11	Hex Key	1	
12	Cross Recessed Pan Head Screw	4	

INSTRUCTIONS

- The dehumidifier adopt an upgraded design, compact structure, easy to operate, and other characteristics, widely used in scientific research, sanitation, commodity storage, underground engineering, and dehumidification in high humidity places such as kitchens, bathrooms, archives, warehouses, etc.
- Can be effectively avoided telecommunications equipment, materials, etc, are damaged due to dampness or rust.
- Dehumidifier reduces humidity in enclosed environments by removing water vapor from the air.

SAFETY & WARNING

When using electrical appliances, basic safety precautions should always be followed including the following:

-  Read all instructions before using this product.
- This appliance can be used by children aged from 8 years and above and persons with reduced physical, sensory or mental capabilities or lack of experience and knowledge if they have been given supervision or instruction concerning use of the appliance in a safe way and understand the hazards involved. Children shall not play with the appliance. Cleaning and user maintenance shall not be made by children without supervision.
- This appliance is designed to use indoor ,not for outdoor.
- The unit is designed only for use with R32(propane) gas as the designated refrigerant.
- The refrigerant loop is sealed.Only a qualified technician should attempt to service!
- Do not discharge the refrigerant into the atmosphere.
- R32(propane)is flammable and heavier than air.
- It collects first in low areas but can be circulated by the fans.
- If propane gas is present or even suspected, do not allow untrained personnel to attempt to find the cause.

- The propane gas used in the unit has no odor.
- The lack of smell does not indicate a lack of escaped gas.
- If a leak is detected, immediately evacuate all persons from the store, ventilate the room and contact the local fire department to advise them that a propane leak has occurred.
- Do not let any persons back into the room until the qualified service technician has arrived and that technician advises that it is safe to return to the room.
- No open flames, cigarettes or other possible sources of ignition should be used inside or in the vicinity of the units.
- Component parts are designed for propane and non-incentive and non-sparking. Component parts shall only be replaced with identical repair parts.
- FAILURE TO ABIDE BY THIS WARNING COULD RESULT IN AN EXPLOSION, DEATH, INJURY AND PROPERTY DAMAGE.
- If the power cord is damaged, do not attempt to repair. It must be replaced with a new power cord supplied by the unit manufacturer in order to avoid a hazard.

■ **WARNING**

Do not use means to accelerate the defrosting process or to clean, other than those recommended by the manufacturer. The appliance shall be stored in a room without continuously operating ignition sources (for example: open flames, an operating gas appliance or an operating electric heater. Do not pierce or burn. Be aware that refrigerants may not contain an odour.

■ **WARNING – Risk Of Fire. Flammable Refrigerant Used. To Be Repaired Only By Trained Service Personnel. Do Not Puncture Refrigerant Tubing. / MISE EN GARDE – Risque d’incendie. Contient un frigorigène inflammable. Confier la réparation à une personne qualifiée. Ne pas perforer la tubulure contenant le frigorigène.**

■ **WARNING – Risk Of Fire. Dispose Of Properly In Accordance With Federal Or Local Regulations. Flammable Refrigerant Used. / MISE EN GARDE – Risque d’incendie. Mettre au rebut conformément aux règlements fédéraux ou locaux. Contient un frigorigène inflammable.**

■ **WARNING –** During using, service and disposal the appliance, please pay attention to symbol similar as left side, which is located on rear of appliance (rear panel or compressor) and with yellow or orange color. It’s risk of fire warning

symbol. There are flammable materials in refrigerant pipes and compressor. Please be far away fire source during using, service and disposal.



**ISO 817
A2L**

SAVE THESE INSTRUCTIONS

PARTS DIAGRAM

Front View

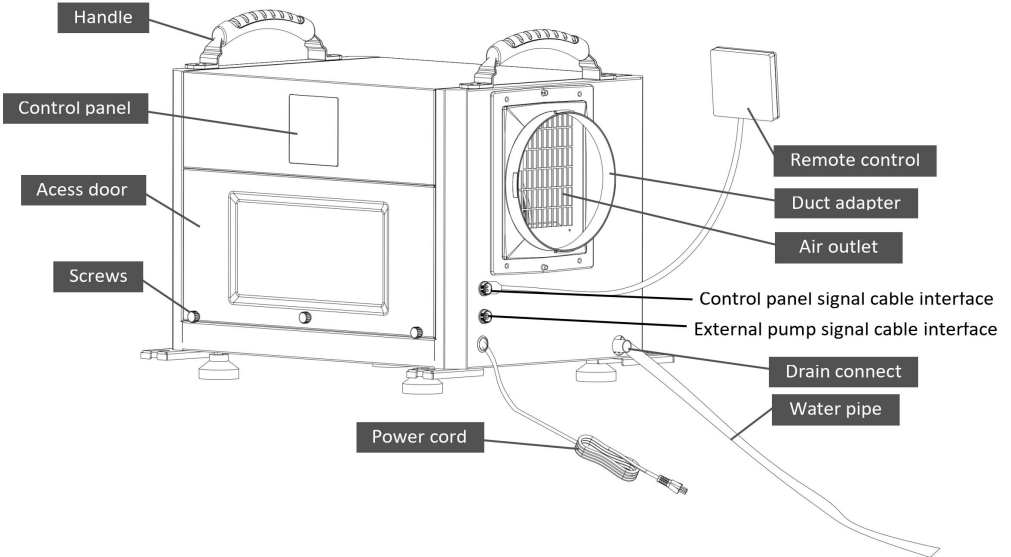

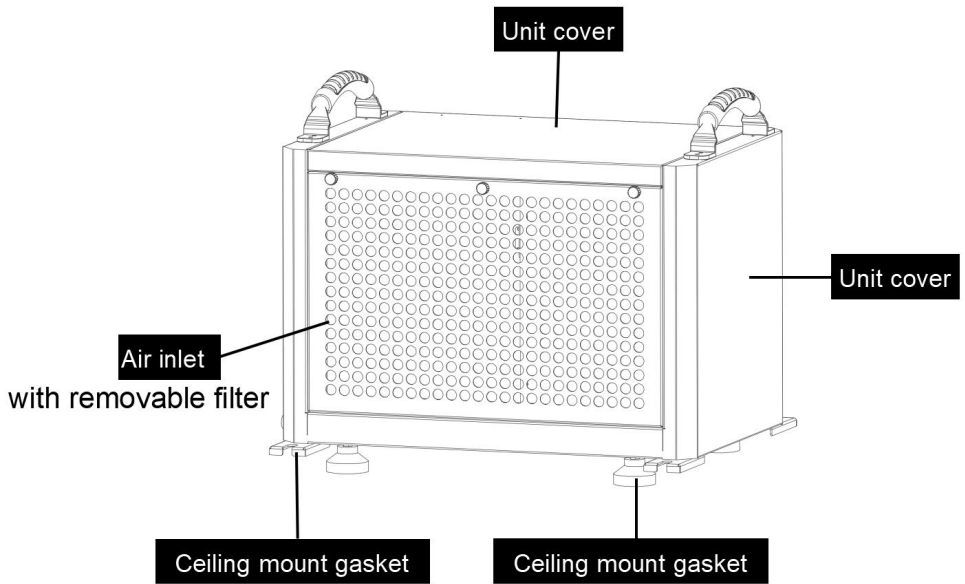

Back View

OPERATIONAL PRECAUTIONS

WARNING-to reduce the risk of fire,electric shock or injury to persons or property:

■ If the supply cord is damaged,it must be replaced by the manufacturer,its service agent or similarly qualified persons in order to avoid a hazard.

The appliance shall be disconnected from its power source during service.

■ Always operate the unit from a power source of equal voltage,frequency and rating as indicated on the product identification plate.

■ Always use a power outlet that is grounded.

■ Unplug the power cord when cleaning or when not in use.

■ Do not operate with wet hands.Prevent water from spilling onto the unit.

■ Do not immerse or expose the unit to rain,moisture or any other liquid.

■ Do not leave the unit running unattended.Do not tilt or turn over the unit.

■ Do not unplug while the unit is operating.

- Do not unplug by pulling on the power cord.
- Do not use an extension cord or an adapter plug.
- Do not put objects on the unit.
- Do not climb or sit on the unit.
- Do not insert fingers or other objects into the air outlet.
- Do not touch the air inlet or the aluminum fins of the wait.
- Do not operate the unit if it is dropped, damaged or showing signs of product malfunction.
- Do not clean the appliance with any chemicals.
- Ensure the unit is far away from fire, inflammable, or explosive objects.
- The unit shall be installed in accordance with national wiring regulations.
- Do not use means to accelerate the defrosting process or to clean, other than those recommended by the manufacture.
- The appliance shall be stored in a room without continuously operation sources (for example: open flames, an operating gas appliance or an operating electric heater).
- The appliance shall be stored so as to prevent mechanical damage from occurring.
- Do not piece or burn, even after use.
- Be aware that refrigerants may not contain an odour.
- Pipe-work shall be protected from physical damage and shall not be installed in an unventilated space, if that space is smaller than 4 m².
- Compliance with national gas regulations shall be observed.
- Keep any required ventilation openings clear of obstruction.
- The appliance shall be stored in a well-ventilated area where the room size corresponds to the room area as specified for operation.

OPERATION INSTRUCTION

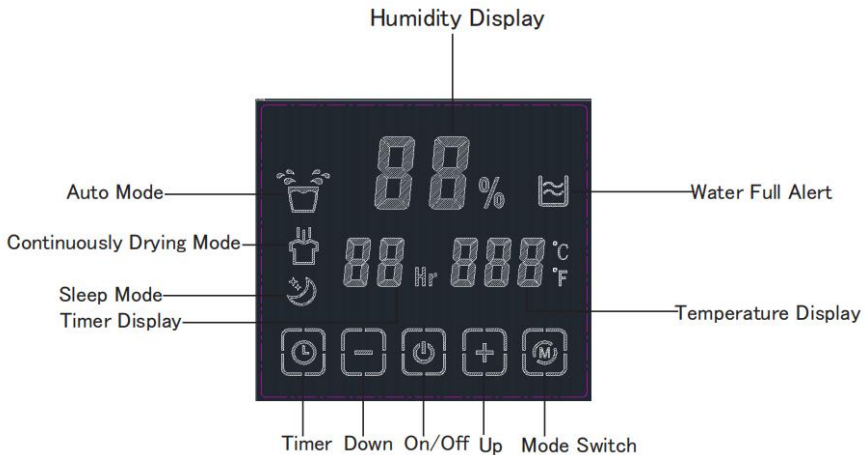

Button Description

A.On/Off(Power) Button

Press the on/off button and the machine will start running (one beep). Press the button again to turn the machine off. This button while on electric, screen light on, machine automatically goes to standby mode, display screen shows environmental humidity.

B.Mode Button

Press the "mode" button, you can choose to working mode, auto mode/ continuously drying mode / sleep mode, the corresponding mode lights on.

C.Timer

Timer/untimer can be set, while the machine is running, press the timer button light goes on, press "+" "-" to set the time to stop the machine, or machine is on stop status, press the timer button and press "+" "-" to set the time to open the machine.

D.ADD Button

Press this button to adjust the set humidity (20-90%) or timing time (0-24h) in an upward cycle. Press the button for 3 seconds to switch between Fahrenheit and Celsius temperatures. Increase the humidity by pressing this button at normal mode, humidity increase 1%RH with each press, buzzer rang each time with the press, press the button for 1 second can increase the humidity continuously;

E.Minus Button

Press this button to down cycle to set humidity (20-90%) or timing time (0-24h). Press the button for 3 seconds, then the temperature display will blink to display the coil temperature, and the ambient temperature will still be displayed after 5 seconds. Decrease the humidity by pressing this button at normal mode, humidity decrease 1%RH with each press, buzzer rang each time with the press, press the button for 1 second can decrease the humidity continuously;

Operating Mode

1.Auto Mode

Default auto mode after on electric (default setting humidity 50%)

a) Environmental humidity $>$ machine set humidity+3%, compressor, and fan start running.

Environmental humidity $<$ machine set humidity+3%, the compressor stops, and the fan stops after a delay of 5 seconds, and the compressor meets the three-minute delay protection.

The machine set humidity+3% \leq environmental humidity \leq machine set humidity+3%, and keeps running in the original state.

b) The setting humidity is adjustable (20%-90%), and the ambient humidity (20%-95%) is displayed after the humidity setting is completed.

2.Continuously Drying Mode

Press the mode button to select the continuously drying mode, and the light is on.

a) The humidity cannot be adjusted, and the compressor can run continuously without being restricted by the ambient humidity (to meet the three-minute delay protection of the compressor)

b) Displays ambient humidity (20%-95%).

3.Sleep Mode (Default humidity 60%, humidity adjustable)

a) Press the mode button to select the sleep mode, and the light is on.

b) In sleep mode, if there is no button operation for 10 seconds, the display will enter a dark state. If there is a button operation in sleep mode, it will return to normal display. After 10 seconds, if there is no other button operation, it will continue to enter the dark display state.

c) In sleep mode, if there is a fault or the water is full, do not beep and the fault

code will be dimly displayed.

Humidity Control

In auto mode or sleep mode, press the up and down adjustment button to cyclically adjust the set humidity. Each time the up (or down) button is pressed, the set humidity will increase (or decrease) by 1%.

During the adjustment of the set humidity, the set humidity will flash and display, after the adjustment is completed, it will flash and display 5 times to confirm, and then switch to display the ambient humidity.

Additional Function

1. Intelligent defrosting: When a defrosting signal is detected, defrosting will start, and the corresponding mode light will flash.

2. Timing function: can set timing/query timing/cancel timing

a) In the non-timing state: press the "timing" key to enter the timing setting state, the digital flashes to display the timing time, and press the up and down keys to adjust the timing time (0~24h) during the flashing period.

b) In the timing state: press the "timing" button, the timing time will be displayed by flashing, and press the "timing" button again during the flashing to cancel the timing.

3. Water-full protection: When the water-full signal is detected, the water-full light is on and the digital flashes to display "FL", the buzzer beeps 5 times to alarm, and the machine is turned off. After power failure and drainage, resume normal operation.

INSTALLATION AND ASSEMBLY OF ACCESSORIES

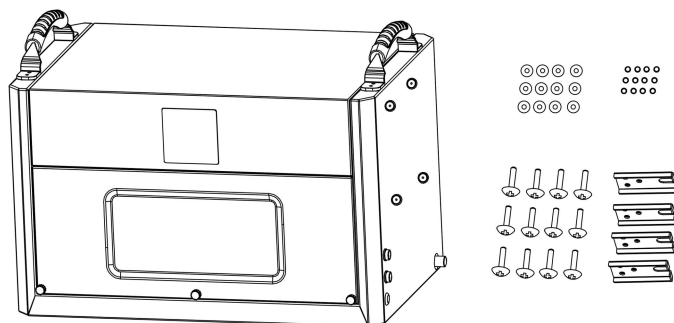

1. Take out the accessories from the packing box: ceiling mount gasket, screws.
 2. Take out the duct adapter and adjustable rubber feet from the machine body.
(only for OL60D-BD063D)
- a. Unscrew the 2 screws under the lower cover, and remove the lower front panel.
 - b. Use a screwdriver to remove the 2 screws on the top cover and remove the top front panel.
 - c. Take out the duct adapter and adjustable rubber feet from the machine body.
 - d. After the accessories are taken out, install the top front panel and lower front panel.

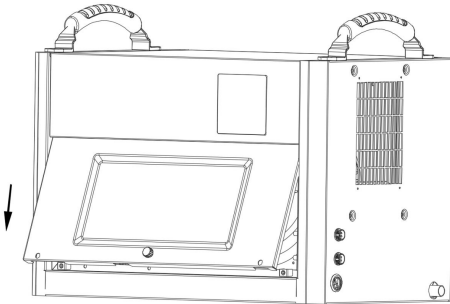

Remove the lower cover screws

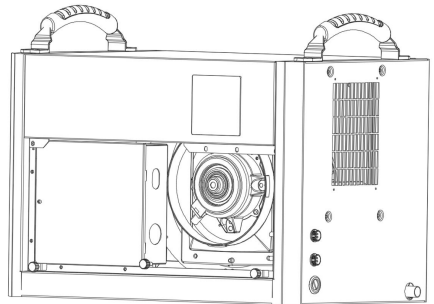

Remove the top cover screws

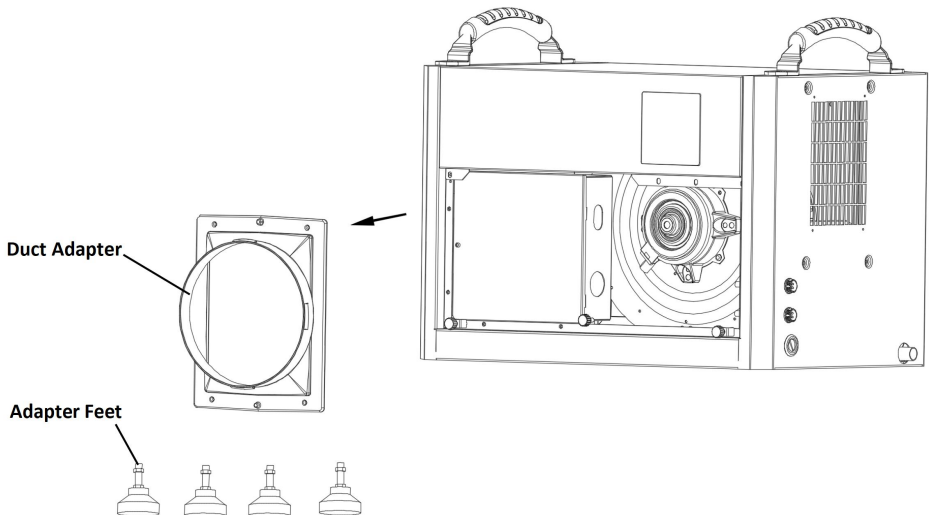

3. Ducting installation

- a. Align the duct adapter with the 4 screw positioning holes on the side.
- b. Lock and fix the duct adapter with screws.
- c. The user can put the exhaust pipe (purchased by the user according to the demand) on the duct adapter, and it must be placed within the buckle position.
- d. You can install the flex duct yourself, the duct adapter diameter is 6.88inch/17.5cm.

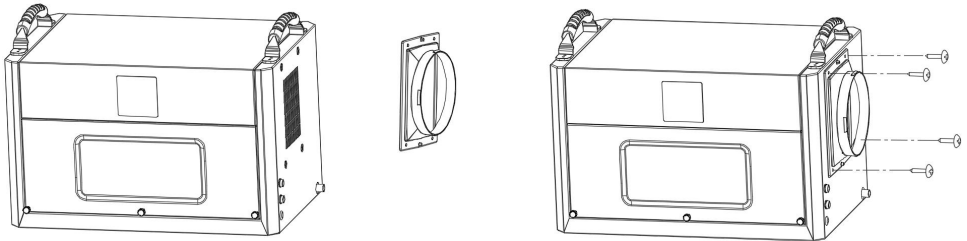

4. Adjustable feet installation

When the machine is placed on the ground or used on some platforms, feet need to be installed

- a. It is necessary to install 4 feet on the bottom plate of the body.
- b. Adjust the height of the position adjustment nuts of the 4 feet to a suitable position.
- c. Assemble the 4 feet in the threaded holes on the bottom plate of the body respectively, and lock tighten.

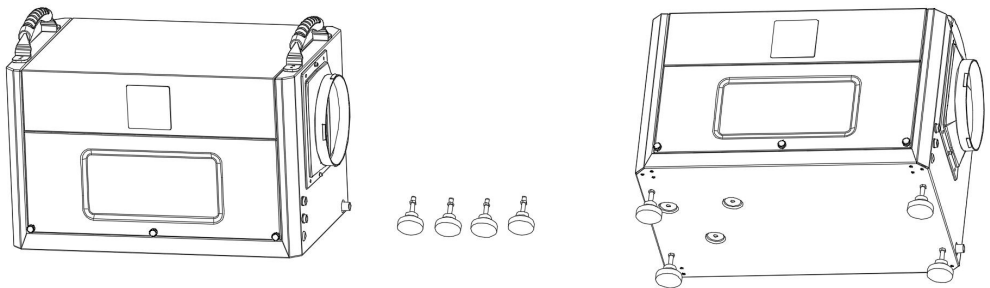

Adjustable Nut

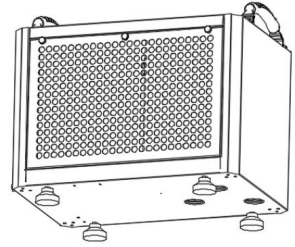
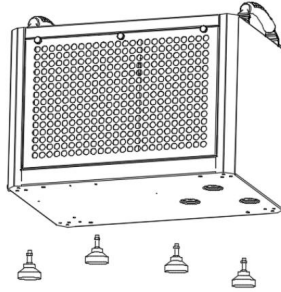
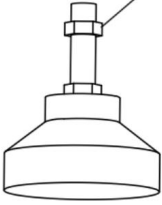

5. Ceiling mount gasket installation

When the machine is suspended in the air, the machine needs to be installed with ceiling mount gasket.

- Install the ceiling mount gasket in the body (accessories: 4 ceiling mount gaskets, 12 spring spacers, 12 flat spacers, 12 screws)-1 screw with 1 spring shim and 1 flat shim.
- Screw the shimmed screw through the boom hole and screw it into the threaded hole on the base plate of the machine and lock tighten.
- Each ceiling mount gasket is installed with 3 screws, and the 4 ceiling mount gasket are assembled on the bottom plate of the machine and locked tighten.

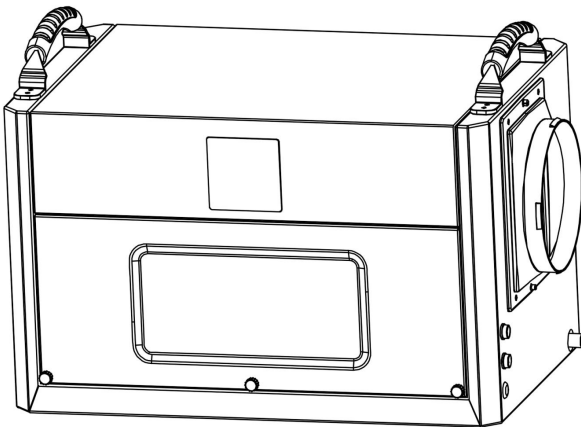

Flat Spacers Spring Spacers

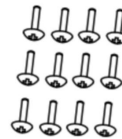

Screws

Ceiling Mount Gaskets

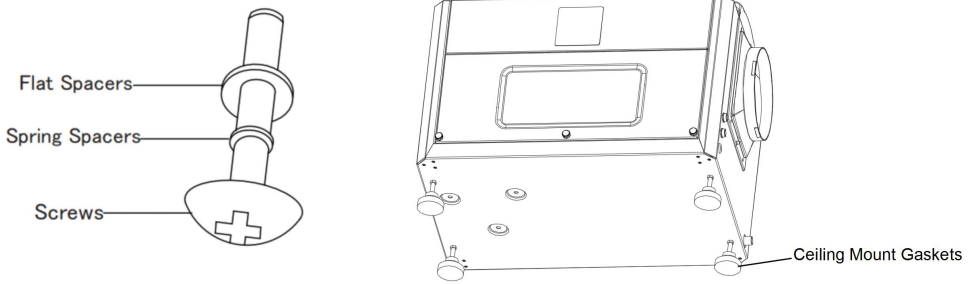

6. Wall assembly method for control panel

When the machine is shipped, the control panel is assembled on the front of the machine.

In order to facilitate the user to install the control panel on the wall, the control panel needs to be removed and the control panel installed on a wall surface that is convenient for operation, as follows.

- a. Remove the 2 handle screws of the lower cover below the machine.
- b. Pinch the handle screws in the middle of the front panel below with your hands and pull outward with gentle force to pull the front panel apart.

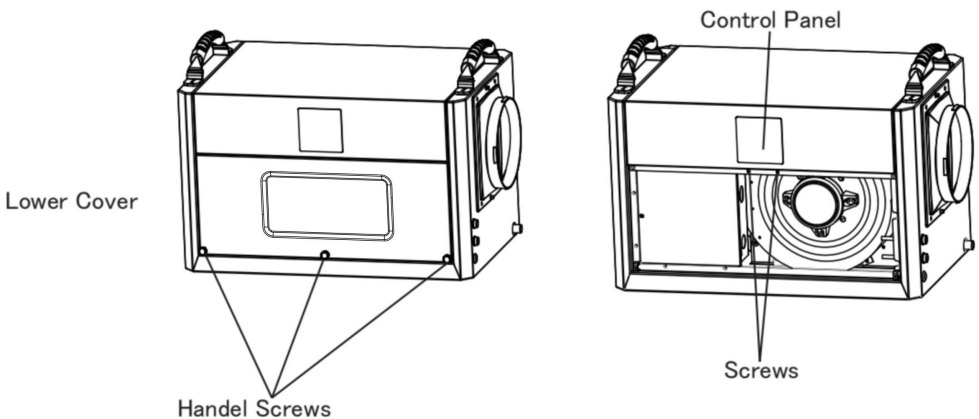

- c. screwdriver to screw down the 2 fixed screws and remove the control panel assembly, then install the cover in the location of the control panel of the machine and fix it with 2 screws.

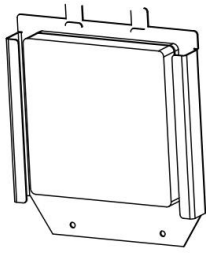

Control Panel Assembly

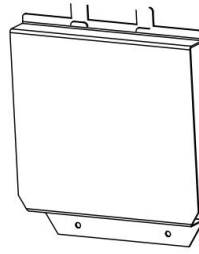

Control Panel Hole Cover

- d. Remove the upper cover of the control panel assembly with a screwdriver; then remove the 2 screws and remove the lower cover.
- e. Mount the lower cover of the control panel assembly on a wall where it can be easily operated.
- f. Connect the signal wires to the terminals of the control panel inside the upper cover of the control panel assembly, install them in place, and then fix the upper cover on the lower cover.

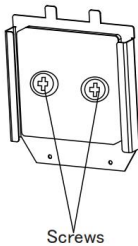

Screws

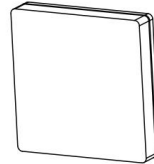
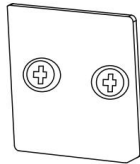

- g. Then plug the other end of the signal cable of the control panel into the signal interface of the machine.

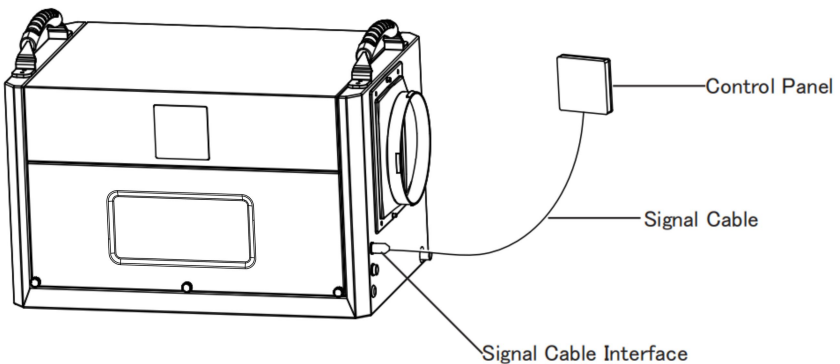

DRAINAGE METHOD

1. Water pipe drainage method

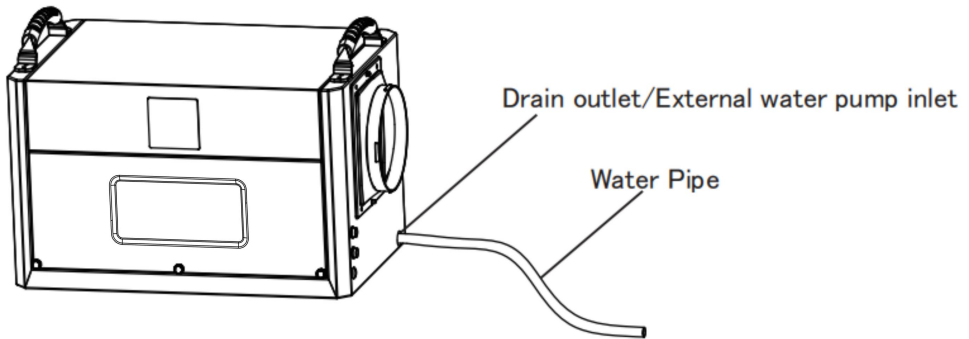

Operation instructions: When using the water pipe drainage method, connect the water pipe at the drain, place the water pipe in place, place the other end of the water pipe at the drain, or at the drain sink, or in the water storage container; turn on the machine to use the water pipe drainage method.

Continuous drainage pipe instructions

Dehumidifiers Adopt Drain by Gravity, the collected condensation water can be drained by gravity. When using gravity to drain:

- (1) Connect the drain hose to the Gravity Drain Outlet;
- (2) Place the unattached end of the hose in a suitable drainage facility. The drainage facility should be lower than the drain outlet of the dehumidifier. (Ensure there are no kinks or other obstructions that will stop the water to flow.)

Note:

- (1) If you use a bucket or other container for water collection, check it regularly to prevent overflows.
- (2) Connecting a drain hose that is too long is not recommended, as it may cause water to back up, causing a leak.
- (3) If the drain hose is too long, water may not drain completely, which can lead to stagnant water and mildew building up inside the hose.
- (4) Before moving the dehumidifier, make sure the condensed water inside is completely drained to avoid water leakage.

Picture 1: Example of error connection

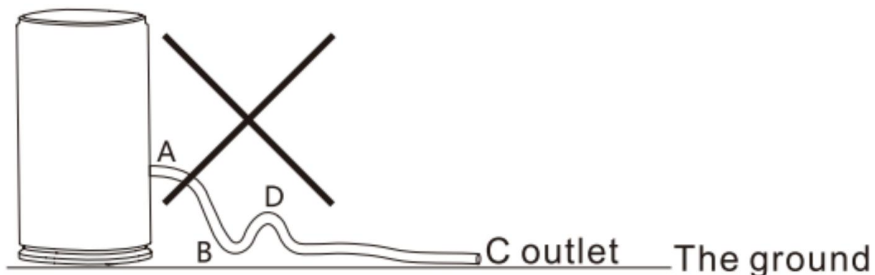

Picture 2: Example of error connection

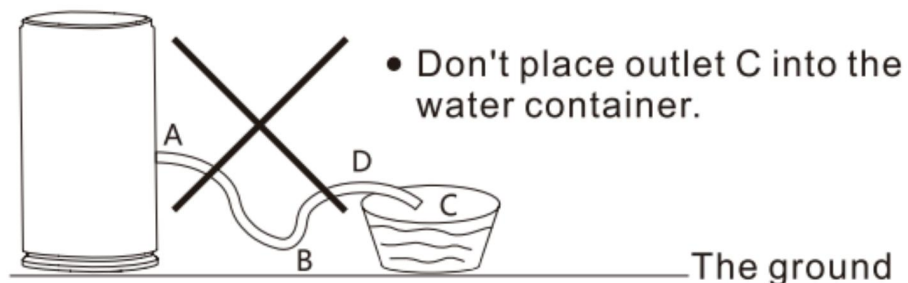

Picture 3: Example of a correct connection

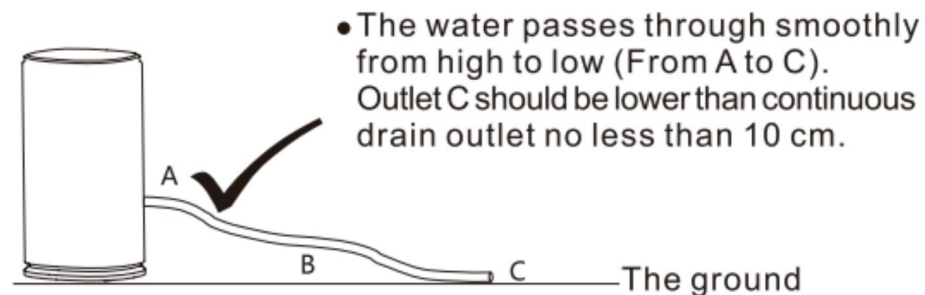

2. External pump drainage method(not include pump,need to buy)

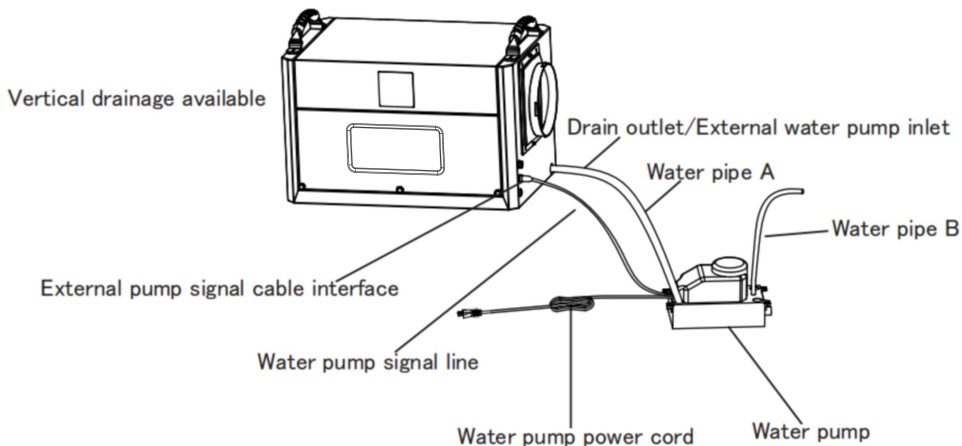

When it is necessary to connect an external water pump, one end of the drainpipe is connected to the water outlet, and the other end is connected to the water inlet of the water pump.

Note: The reserved external water pump signal input port cannot be connected to the power supply, so as not to cause the main board of the product to burn out.

Operating instructions: When using the pump drainage method, the operation is as follows.

1. The two ends of the water pipe A, one end connected to the machine drain, must be placed in place; the other end placed in the water pump inlet, placed firmly.
2. Connect one end of the water pipe B to the water pump discharge port, and place the other end of the water pipe in the sewer opening, or drainage sink, or water storage container; Note: the length of the water pipe B must be within the range of the pump's head.
3. Plug one end of the pump signal line into the pump signal line interface of the machine and assemble it in place.
4. Plug the power cord of the pump into a solid, suitable socket. Pump power on, turn on the machine can be used to drain the water pump.

CLEANING AND MAINTENANCE

Note: Before cleaning and maintaining the machine, please make sure to turn off the machine and unplug it from the power source to prevent electric shock.

Cleaning :

Before doing any cleaning and maintenance work on the machine, the machine must be turned off, unplugged, and no water should be spilled on the machine.

Use a soft, damp cloth to clean the casing. Do not use chemical solvents such as benzene, alcohol or gasoline, otherwise, the machine casing will be damaged or even deformed.

Filter cleaning:

The machine is equipped with a washable filter, it is recommended to clean the filter every 2 weeks. If the filter is blocked by dust, it will reduce the efficiency of the machine.

1. Cleaning the filter.

a. Remove the filter

(1) Remove the handle screws on both sides above the air inlet frame.

(2) Pinch the handle screws in the middle above the air inlet frame with your hands, pull outward with a little force, and pull the air inlet frame rotate (such as the rotating arrow)

(3) .Remove the filter.

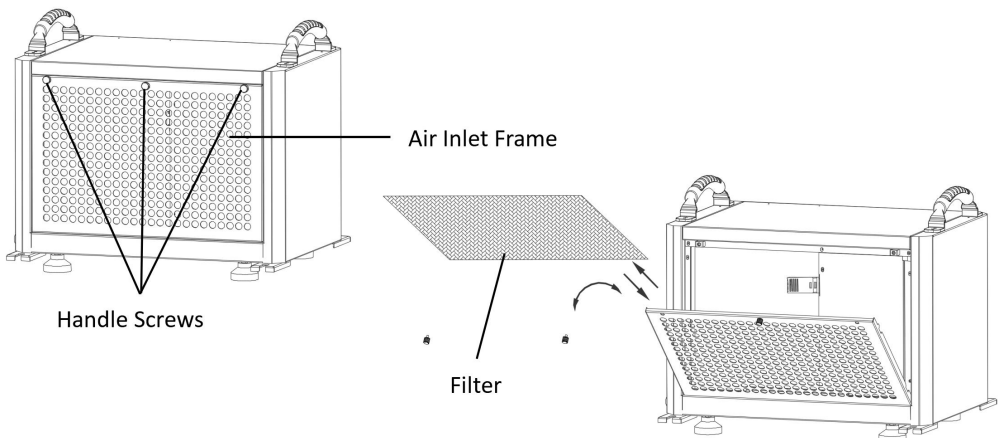

b. Clean the filter

Use a vacuum cleaner to gently absorb the dust on the surface of the filter. If the filter is very dirty, you can use tap water to rinse the filter, and completely cool and dry it, then put it back into the forward air sheet, which can improve the performance of the machine.

Suggestion: Clean the filter once after every 3 months of use.

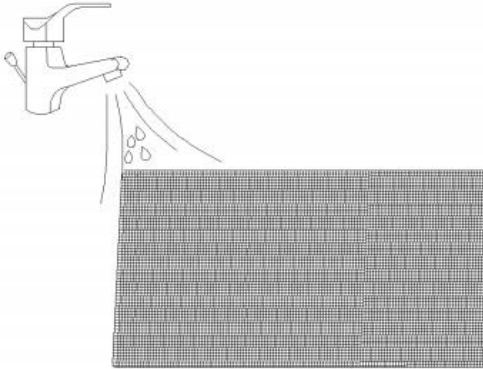

c. Assemble the filter and air inlet frame

(1) The filter will be put into the assembly of the air inlet frame buckle position, need to be assembled in place.

(2) The air inlet frame will be held up with force, the air inlet frame will be rotated and assembled to the machine inside, which must be assembled in place.

(3) Lock the handle screws on both sides above the air inlet frame to fix it.

2. Machine body cleaning

Use a soft, slightly damp cloth to wipe the body.

3. Machine storage

When you do not use this product for a long time and intend to store it, pay attention to the following steps.

a. Drain the water from the machine body.

b. Tidy up the power cord.

c. Clean the filter.

d. Place it in a fresh and dry environment.

SAFETY PRECAUTIONS ON SERVICING

Please follow these warnings when to undertake the following when servicing an appliance with R32.

1.Checks to the area

Prior to beginning work on systems containing flammable refrigerants,safety checks are necessary to ensure that the risk of ignition is minimized. For repair to the refrigerating system, the following precautions shall be complied with prior to conducting work on the system.

2.Work procedure

Work shall be undertaken under a controlled procedure so as to minimize the risk of a flammable gas or vapor being present while the work is being performed.

3.General work area

All maintenance staff and others working in the local area shall be instructed on the nature of work being carried out. Work in confined spaces shall be avoided. The area around the work space shall be sectioned off. Ensure that the conditions within the area have been made safe by control of flammable material.

4.Checking for presence of refrigerant

The area shall be checked with an appropriate refrigerant detector prior to and during work, to ensure the technician is aware of potentially flammable atmospheres. Ensure that the leak detection equipment being used is suitable for use with flammable refrigerants,i.c. no sparking,adequately sealed or intrinsically safe.

5.Presence of fire extinguisher

If any hot work is to be conducted on the refrigeration equipment or any associated parts, appropriate fire extinguishing equipment shall be available to hand. Have a dry powder or CO₂ fire extinguisher adjacent to the charging area.

6.No ignition sources

No person carrying out work in relation to a refrigeration system which involves exposing any pipe work that contains or has contained flammable refrigerant shall use any sources of ignition in such a manner that it may lead to the risk of fire or explosion. All possible ignition sources, including cigarette smoking,should be kept sufficiently far away from the site of installation, repairing, removing and disposal, during which flammable refrigerant can possibly be released to the surrounding

space. Prior to work taking place, the area around the equipment is to be surveyed to make sure that there are no flammable hazards or ignition risks."No Smoking" signs shall be displayed.

7. Ventilated area

Ensure that the area is in the open or that it is adequately ventilated before breaking into the system or conducting any hot work. A degree of ventilation shall continue during the period that the work is carried out. The ventilation should safely disperse any released refrigerant and preferably expel it externally into the atmosphere.

8. Checks to the refrigeration equipment

Where electrical components are being changed, they shall be fit for the purpose and to the correct specification. At all times the manufacturer's maintenance and service guidelines shall be followed. If in doubt consult the manufacturer's technical department for assistance. The following checks shall be applied to installations using flammable refrigerants:

- The charge size is in accordance with the room size within which the refrigerant containing parts are installed;
- The ventilation machinery and outlets are operating adequately and are not obstructed.

TRANSPORTATION AND CUSTODY

During transportation, this product should be handled preciously to prevent violent vibration. Generally, the packaged product should not be stored in the open air for a long time. It should be placed in a well-ventilated, non-corrosive gas warehouse. It should not be placed upside down. Set unit upright. Always store, transport, and use the unit in a horizontal position. If the unit is ever placed in a vertical position, return it to the horizontal position and let it stand for at least 24 hours before turning it on.

Rainproof measures should be adopted when stored temporarily. For best results, operate your dehumidifiers in an enclosed area. Place your dehumidifier away from obstructions, and keep it away from anything that could block airflow into and out of the unit.

TROUBLESHOOTING

Symptom	Cause	Solution
Machine Won't Run	Power outage	Restoration of power supply
	Power plug is not connected well	Connect the plug to the socket
	Room temperature over 113°F or below 38°F	The machine's protection device is activated so that the machine does not run
Low Air Flow	Filter with dirt accumulation	Cleaning filters
	The air inlet or outlet is blocked	Remove obstructions
	Refrigerant leakage	Contact agent or manufacturer for repair
Water Leakage	Clogged outlet pipe	Remove the panel to remove the blockage at the water pipe or water outlet
Loud Noise	Machine Is Not level	Move the dehumidifier to flat, firm ground
	Filter Mesh is Blocked	Clean the filter mesh according to instructions listed in manual
Trouble Code:E1	Temperature and humidity sensor failure	Check, or replace the temperature and humidity sensor
Trouble Code:E2	Coil sensor failure	Check, or replace the coil sensor
Trouble Code:CL	When the ambient temperature $T_r < 36\text{ }^\circ\text{F}$, "CL" will be displayed and the compressor will stop immediately, and the fan delay will be executed according to the set value (F1 default 0, delay 5 seconds to stop) When the ambient temperature rises to $2\text{ }39\text{ }^\circ\text{F}$, normal operation will resume.	

Trouble Code:CH	When the ambient temperature $Tr > 113^{\circ}\text{F}$, "CH" will be displayed, the compressor will stop immediately, and the fan delay will be executed according to the set value (F1 default 0, delay 5 seconds to stop)when the ring temperature s 108°F , normal operation will be resumed.
Trouble Code:LO	When the ambient humidity $Hr < 20\%$, "LO" will be displayed, the compressor will stop immediately, and the fan delay will be executed according to the set value (F1 default 0, delay 5 seconds to stop). After the humidity rises $> 20\%$, resume normal work.
Trouble Code:HI	When the ambient humidity $Hr > 95\%$, "HI" is displayed and the compressor and fan work normally.After the humidity falls back to $< 95\%$, it will resume normal operation

VEVOR[®]

TOUGH TOOLS, HALF PRICE

Technical Support and E-Warranty Certificate

www.vevor.com/support

Made in China