

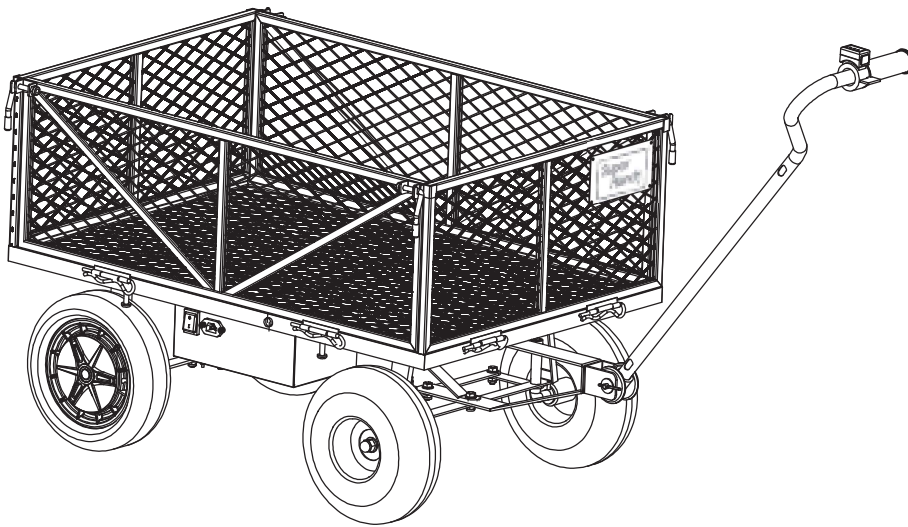

Power-assisted Pull Wagon Operator's Manual



WARNING:

Carefully review and understand all **INSTRUCTIONS** prior to operating this device. Failure to follow the safety rules and other basic safety precautions may result in serious personal injury. Keep these instructions in a safe place and accessible so that they can be reviewed as required. Keep these instructions to assist in future servicing needs.

WARNINGS

For your own safety, always follow these basic precautions when using this appliance.

1. Read the user Manual carefully for operating instructions. Read all instructions in this manual before use.
2. DO NOT use attachments other than those available from the manufacturer.
3. DO NOT alter this product in any manner; doing so is dangerous and will void all warranties.
4. DO NOT operate under the influence of drugs or alcohol.
5. DO NOT continue to use this product in the event of mechanical or electrical failure.
6. DO NOT overload.
7. Keep your work area clean and well lit. Cluttered benches and dark areas invite accidents.
The floor must not be slippery from wax or dust.
8. DO NOT turn violently during use to avoid casualties or property losses caused by falling goods.

TECHNICAL SPECIFICATIONS

Load Capacity	440LBS / 200KG
Motor Power	24Vdc, 180W
Storage space (LxWxH)	33" x 21.8" x 11" (838 x 553 x 280mm)
Wheel Size	10" pneumatic wheel
Lead Acid Battery	12V-7Ah x2
Weight	72LBS (32.8KGS)
Assemble size	40" x 24.8" x 40.3" (1017 x 630 x 1025mm)

MAIN COMPONENTS

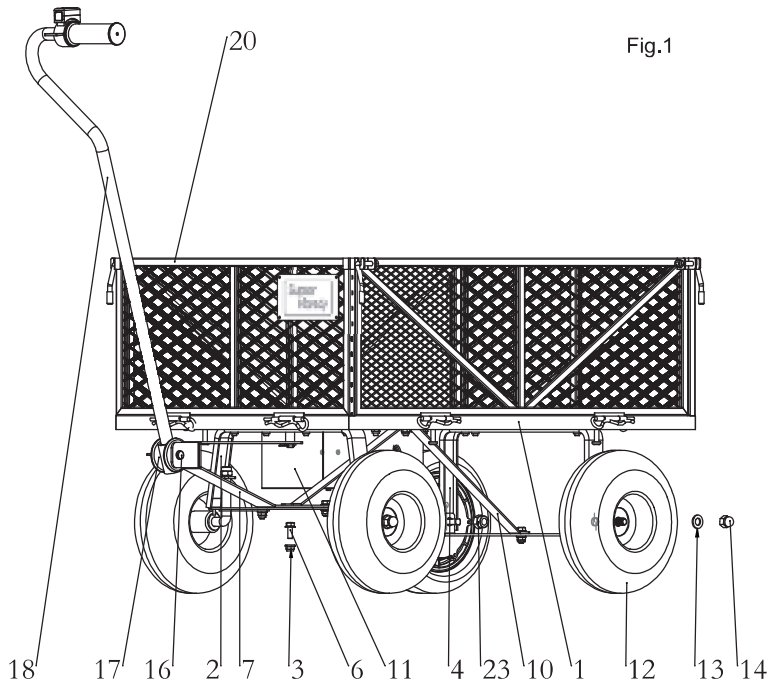

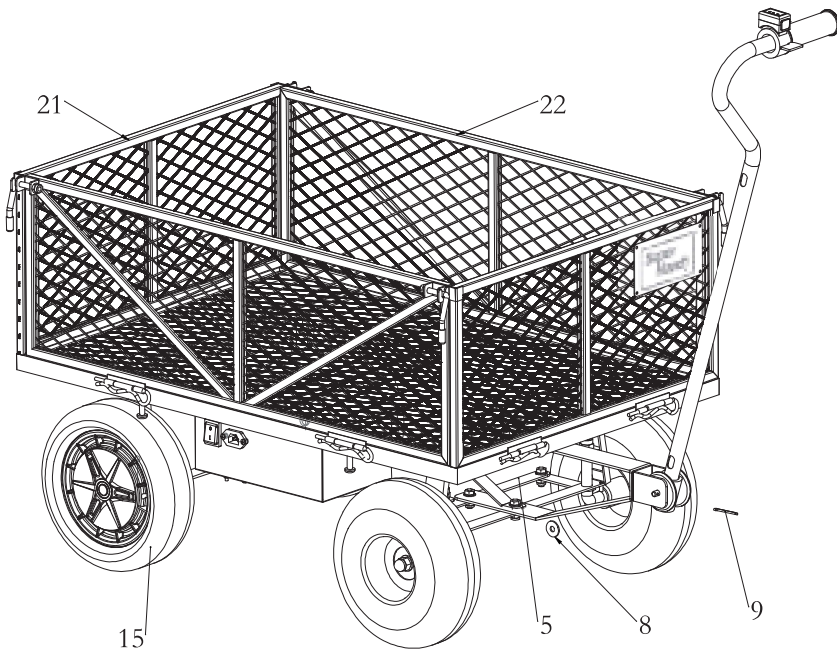

Fig.2

Part No.	Description	Q'ty	Part No.	Description	Q'ty
1	Main frame	1	13	Flat washer,M14	3
2	Steering bracket	1	14	Cap Nut, M12	3
3	Hexagonal flange nut, M8	17	15	10" Hub motor wheel	1
4	Fixed bracket	1	16	Pin	1
5	Steering Bracket Linkage	1	17	Plastic sleeve	1
6	Hexagonal flange bolt, M8x20	5	18	Handle bar	1
7	Towbarbracket	1	19	B type pin, 5*110	8
8	Flat washer,M10	2	20	Front fence	1
9	R-Pin,2.5x30	2	21	Rear fence	1
10	Wheel bracket support plate	1	22	Left/Right fence	2
11	Battery box	1	23	Motor shaft nut, M14x1.5	1
12	10" Pneumatic wheel	3			

ASSEMBLY

STEP 1 Assemble the fixed bracket

- Assemble the wheel bracket support plate(10) to the main frame (1), fixed by 1pc M8 hexagonal flange nut (3).
- Assemble the fixed bracket (4) to the main frame(1), fixed by 3pcs M8 hexagonal flange nut(3).
- Connect the fixed bracket (4) and wheel bracket support plate(10), fixed by 1pc M8 hexagonal bolt (6) and M8 hexagonal flange nut (3).
- The support plate (10) is under the fixed bracket (4).

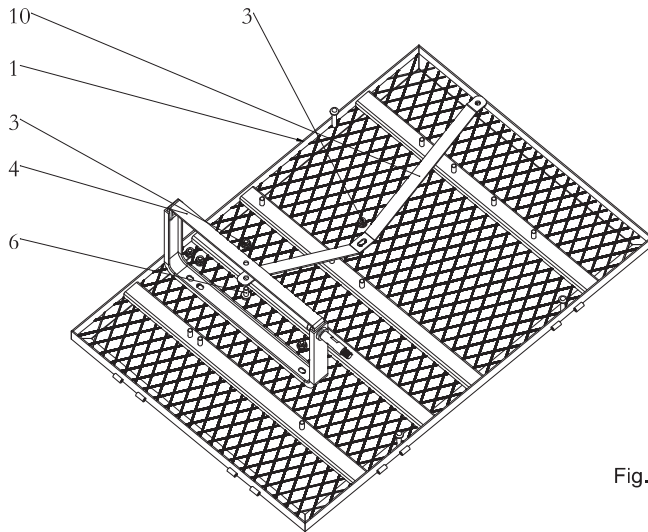

Fig.3

STEP 2 Assemble the steering bracket

- Assemble the steering bracket (2) to the main frame (1) by 4pcs M8 hexagonal flange nut (3).
- Assemble the steering bracket linkage rod (5) to the steering bracket (2) by 2pcs M8 hexagonal flange nut (3) and 2pcs M8x20Hexagonal flange bolt(6).
- The linkage rod (5) is under the steering bracket (2).
- The wheel bracket support plate (10) is under the steering bracket (2).

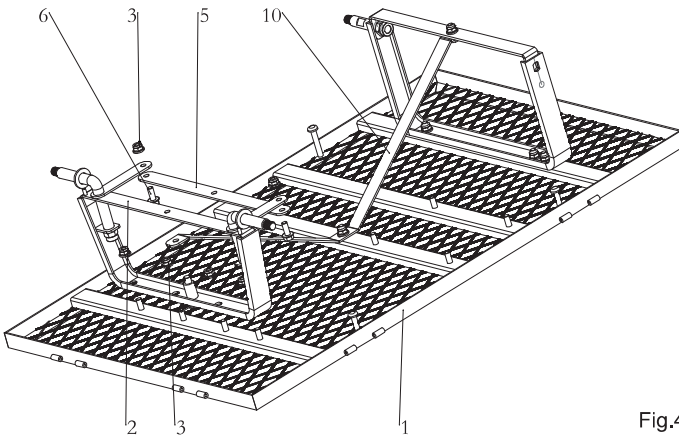

Fig.4

STEP 3 Assemble the towbar bracket

- a. Assemble the towbar bracket (7) to the steering bracket (2), fixed by one flat washer (8) and R-Pin (9).
- b. Assemble another lever of towbar bracket (7) to the steering bracket linkage rod (5), fixed by one M8 nut (3) and one M8x20bolt(6).
- c. Connect the towbar bracket(7), the steering bracket (2) and the wheel bracket support plate (10), fixed by one M8 nut (3) and one M8x20bolt(6).
- d. Notice, the lever of towbar bracket (7) is on the top.

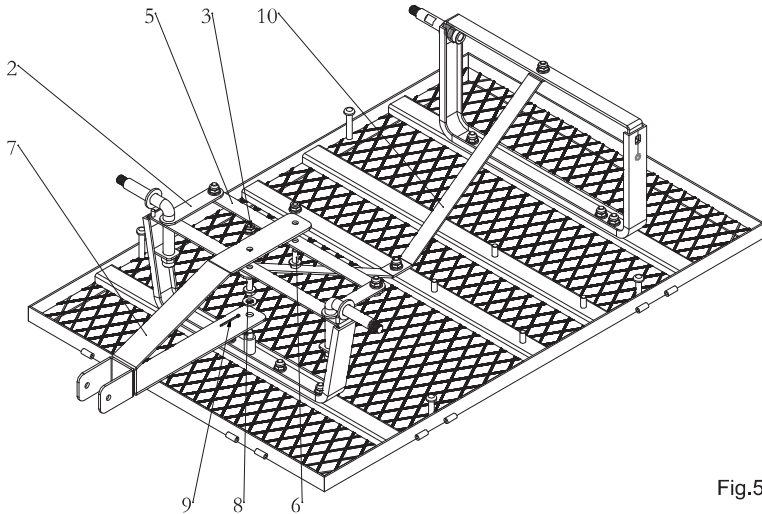

Fig.5

STEP 4 Assemble the battery box

- a. Assemble the battery box (11) to the main frame (1) by 4pcs M8 Hexagonal flange nut (3).
- b. Notice, the switch of battery box is at outside.

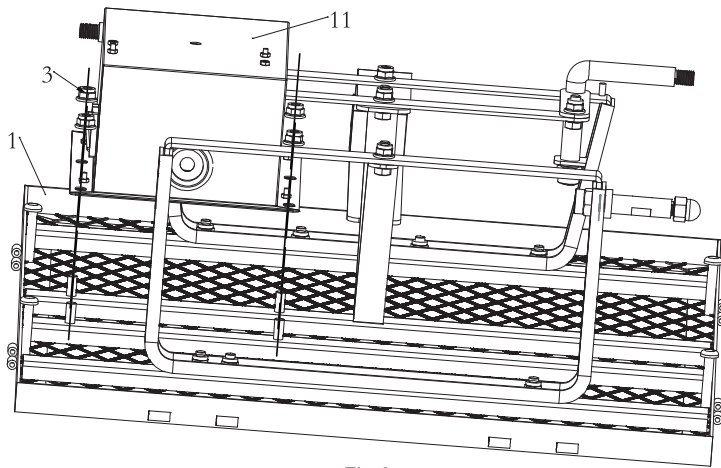

Fig.6

STEP 5 Assemble the wheels

- a. Assemble the motor hub wheel (15) to the fixed bracket (4), tightened by flat washer (13) and motor shaft nut (23). Only one position is suitable for this wheel.
- b. Assemble the 3pcs pneumatic wheels (12) to the steering bracket (2) and fixed bracket (4), fix them by flat washer (13) and cap nuts (14).

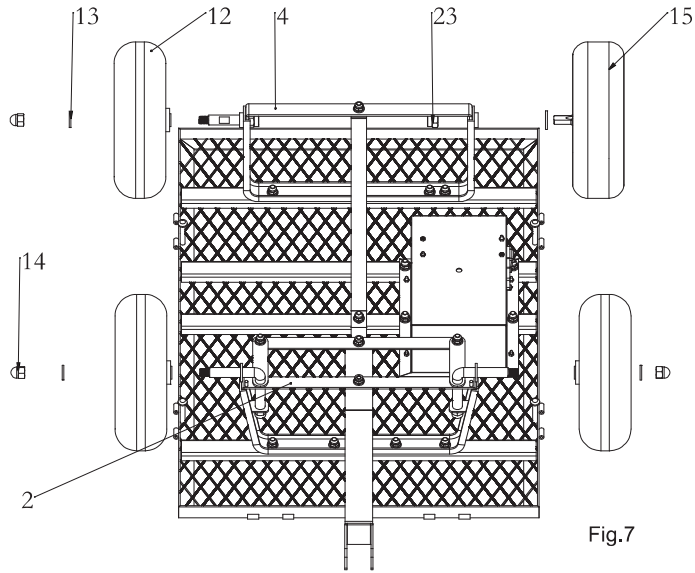

Fig.7

STEP 6 Assemble the handle bar

- a. Insert the handle bar (19) to the plastic sleeve (17), and together insert to the opening of steering bracket.
- b. Insert the pin (16) go through the holes of plastic sleeve (17) & handle bar (19), and lock the pin by the washer (8) and R-Pin (9).

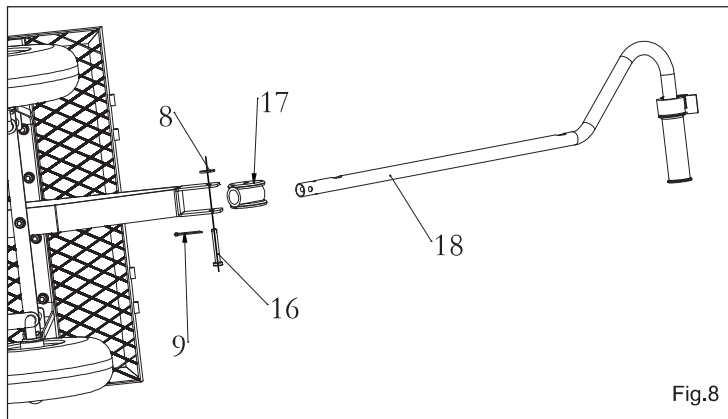

Fig.8

STEP 7 Assemble the fence

- a. Assemble the front fence (20) and rear fence (21) to the main frame (1), lock both by the B-type pins (19)
- b. Notice: The front fence has the logo plate which face to handle bar.

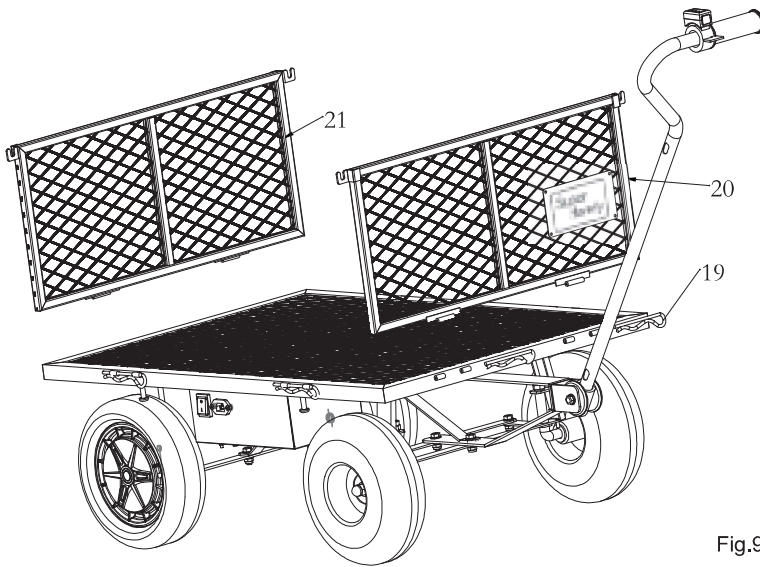

Fig.9

STEP 8 Assemble the left/right fence

- a. Assemble the left/rear fence (22) to the main frame (1), lock both by the B-type pins (19).
- b. Notice: The locking pin of the fence should be fitting with front/rear fence which face to outside.

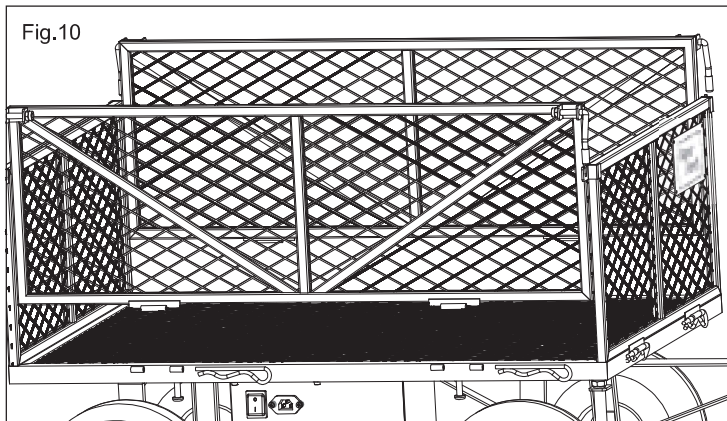

Fig.10

STEP 9 Connect the cables

- a. Connect the cable of motor to the short cable come from the battery box (Fig.12). Notice the alignment arrow at the connecting plug.
- b. Connect the long cable come from the battery box to the throttle at handle bar (Fig.13). Notice the wire must go through the holes of bar, to avoid the wire broken.



OPERATION

- 1. Power on the switch (A) of power box. The LED (B) of handle bar will be light.
- 2. Press on the throttle (C) to move the wagon. The speed can control by pressing. The press the throttle lightly, speed is slow. Press down the throttle, maximum speed is active.
- 3. Press the button (D) that can change the wagon forward/backward moving direction.
- 4. While wagon has the heavy loading, the wheel is spinning when you press on the throttle. Try to press on the throttle and pull the wagon to overcome friction and move. This is the power-assisted wagon, rather than all powered wagon.

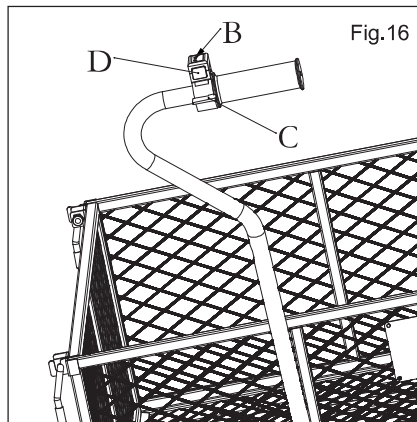
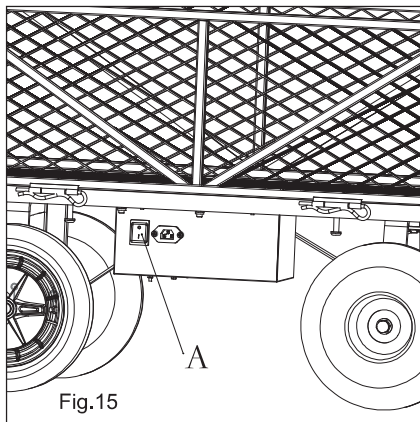

TROUBLE SHOOTING

Problem(s)	Possible Cause	Corrective Action
Wagon is not moving	The power switch isn't ON	Switch on the power
	The battery wire is loose	Open the battery box and check battery status
	The wire is broken	Check if wires are ok, change wires if broken
	The controller is defected	Connect customer service
Wagon is moving intermittently	Lower power	Charging battery
	Over load 450LBS	Decrease the loading and try to move again
	The wire is loosed or broken	Check if wires are ok, change wires if broken
Moving slowly, or wheel spinning	Over load 450LBS	Decrease the loading and try to move again
	Road is not flat	Un-flat surface, soft surface will make wagon slowly moving, and wheel spinning
	Lower power	Charging battery
	The wire is loosed or broken	Check if wires are ok, change wires if broken
Wagon can not turn properly	The steering bracket is not assembled correctly	Check the parts and see if components assembled well

MAINTENANCE AND STORAGE

Check to be sure all nuts and bolts are tight to assure the equipment is in safe working condition prior to each usage.

WARRANTY

Twelve (12) months for workmanship of the product, except for wearing parts. Warranty period starts from the product purchase date. Warranty covers material quality and workmanship only. Warranty does not cover product for issues caused by improper usage or any operation not in accordance with the specifications of this manual. Any modification or tampering with the product in any way voids the warranty.



Great Circle USA
Support Line: 1-866-493-0524
Email: help@greatcircleus.com
www.greatcircleus.com
www.greatcircleca.com



US



CA

Scan me to get more new products.