

INSTRUCTION MANUAL

ADS

ESPAÑOL

ENGLISH

SCHULZ

**INDEX**

1. SIMBOLOGÍAS SIMBOLOGÍAS SYMBOLS	3
2. INTRODUCTION.....	50
3. SRS - AIR DRYER SHIPPING AND RECEIVING INSPECTION	50
4. APPLICATION.....	50
5. SAFETY INSTRUCTION.....	51
6. TECHNICAL FEATURES	52
7. CORRECTION FACTORS	53
8. INSTALLATION	54
9. INSTRUMENT PANEL	57
10. OPERATION.....	62
11. PREVENTIVE MAINTENANCE.....	63
12. REMOVING MAINTENANCE PARTS - DISPOSAL.....	65
13. CORRECTIVE MAINTENANCE	65
15. ENVIRONMENTAL GUIDELINES AND RECOMMENDATIONS	65
14. FAILURE DIAGNOSTICS.....	66
16. WARRANTY	68
17. SERVICE REPORT	69
ANEXOS ANEXOS ATTACHMENTS	72

Schulz S.A. congratulates you on your purchase of another quality SCHULZ product.

A company certified by **ISO 14001**

Environmental Management Standard.

The SCHULZ products merge technology with easy-to-use operation.



IMPORTANT

This Instruction Manual contains important information about the use, installation, maintenance, and safety procedures for the ADS - Compressed Air Dryer. It must be on hand at all times for the operator. Before operating this equipment or performing any maintenance, please read these operating instructions fully for complete understanding, as to avoid personal injury to the operator or damage to the ADS - Compressed Air Dryer and its supplies. The drawings and photographs in this instruction manual are solely for guidance purposes.



IMPORTANT

Use only original SCHULZ replacement parts for your ADS - Compressed Air Dryer purchased at our Schulz Authorized-Technical/Distributor staffed with trained and competent professionals in its maintenance and operation.

2. INTRODUCTION



WE RECOMMEND READING THESE INSTRUCTIONS ENTIRELY FOR PROPER OPERATION OF YOUR SCHULZ PRODUCT.

It will help you to increase the performance, enhance safety and guide the operator in preventive maintenance procedures in equipment operation.

Black numbers in the text, show the key parts and functions - Chapter - Main components and their functions.

If there is any problem that cannot be solved by the information provided in this manual, please contact the nearest Schulz Authorized Dealer.

3. SRS - AIR DRYER SHIPPING AND RECEIVING INSPECTION

Inspect and verify if any damages have occurred in shipment. If confirmed, please inform the shipping company at receiving time. Certify that all damaged parts are replaced and mechanical and electrical problems are corrected before operating the ADS - Compressed Air Dryer. Dryers are packaged in wooden crates completely covered by semitransparent plastic. Moving the equipment must be done on a forklift or pallet truck.



IMPORTANT

Keep the dryer in vertical position

4. APPLICATION







This dryer has been designed, manufactured and tested for the purpose of separating the humidity normally contained in compressed air. Any other use has to be considered improper.

The Manufacturer will not be responsible for any problem arising from improper use; the user will bear responsibility for any resulting damage.







Moreover, the correct use requires the adherence to the installation instructions, specifically:







- Voltage and frequency of the main power.
- Pressure, temperature and flow-rate of the inlet air.
- Ambient temperature.
- The purpose of the machine is the separation of water and eventual oil particles present in compressed air.
- The dried air cannot be used for breathing purposes or for operations leading to direct contact with foodstuff.
- This dryer is not suitable for the treatment of dirty air or of air containing solid particles.

5. SAFETY INSTRUCTION

-  **1.** This equipment, if improperly used, can cause physical and material damage. To avoid these damages, follow the instructions below:
 - This equipment may not be used by people with physical, sensorial, or mental handicaps. Or without experience or knowledge.
 - People without the proper experience or knowledge may use this equipment only if properly supervised or instructed to its use by someone who is liable for his or her safety.
 - Do not use your equipment while tired, under the influence of medication, alcohol or drugs. Lack of attention during operation may result in serious personal injury;
 - Can cause mechanical or electrical interference on nearby sensitive equipments;
 - Must be installed and operated in places that are ventilated and protected against moist presence and water falling.
 - 2.** The equipment model must be chosen in compliance with the established use. don't exceed maximum capacity, if required, acquire a more suitable tool for the application. This will increase the efficiency and safety in the work;
 - 3.** Always use suitable personal protective equipment (PPE), as each application, such as dust glasses and masks, non-skid safety shoes and ear protection. This reduces the risks against personal injury;
 -  **4.** Not use long wear clothing, or jewelry that may come into contact with the moving part of the tool during use. If you have long hair, contain it before using the tool;
 -  **5.** While in use, this equipment has electrical components and hot moving parts;
 -  **6.** Compressed air is a highly hazardous energy source. Never work on the dryer with pressure in the system. Never point the compressed air or the condensate drain outlet hoses towards anybody. The user is responsible for the proper installation of the dryer. Failure to follow instructions given in the "Installation" chapter will void the warranty. Improper installation can create dangerous situations for personnel and/or damages to the machine could occur.
 -  **7.** The compressed air might contain pollutants that will cause harm to the health of humans, animals, ambient or foods, among others. The compressed air must be treated with adequate filters, according to application and use requirements. Consult the factory or a SCHULZ AUTHORIZED DEALER. for more information.
- 8. To reduce the risk of electrical shock;**
- For protection against electric shock, it is recommended to install a residual current circuit breaker. Consult an electrician to select and install this safety device;
 - Do not use the equipment barefoot, in wet or very humid places, do not touch metal surfaces attached to the ground or grounded, such as pipes, motors, gutters, fences, windows, doors, metal gates, etc, this increases the risk of electric shock;
 - Before cleaning or performing maintenance, disconnect the machine from the electrical network;
 - Do not make splices in the cord. If required, ask for a power cord replacement at the nearest Schulz Authorized Dealer (The costs of power cable replacement are the sole responsibility of the customer).
 - Power outlet must be compatible to the tool plug. To reduce the risk of shock, do not change the plug characteristics and do not use adapters. If required, replace the outlet with a plug suitable model.
-  • Do not use your electric equipment in explosive atmospheres (gas, flammable liquid or dust). The motor generate sparks that may cause explosion;
- Make sure the power trigger is in the "off" position before connecting the equipment to the power grid.
- 9.** Maintenance / Operation:
- 10.** Do not allow the compressor to come in contact with any flammable substances;
 - 11.** Never clean the compressor with solvents or any other flammable substances, use a neutral detergent.
 - 12.** Only qualified personnel are authorized to service electrically powered devices. Before attempting maintenance, the following conditions must be satisfied:
 - Ensure that main power is off, machine is locked out, tagged for service and power cannot be restored during service operations.
 - Ensure that valves are shut and the air circuit is at atmospheric pressure. De-pressurize the dryer.
 - Warranty does not apply to any unit damaged by accident, modification, misuse, negligence or misapplication. Unauthorized alterations will immediately void the warranty.
 - 13.** Remove all adjustment tools before turning your equipment on. A tool or part stuck in moving of the equipment may cause serious injuries;
 - 14.** In case of fire, use an approved fire extinguisher, water is not an acceptable means in cases of electrical fire.
 - 15.** In presence of any equipment abnormally, suspend its operation immediately and contact the nearest SCHULZ AUTHORIZED DEALER.

6. TECHNICAL FEATURES

MODEL ADS		10	15	20	35	50	75							
Flow	scfm	10	15	20	35	50	75							
	ℓ /min	283	425	566	991	1415	2123							
	m³/h	17	25	34	59	85	127							
 Nominal inlet air pressure	psig (barg)	100 (7)												
 Maxima inlet air pressure	psig (barg)	232 (16)										203 (14)		
Electric Voltage	V	1/115/60	1/230/60	1/115/60	1/230/60	1/115/60	1/230/60	1/115/60	1/230/60	1/115/60	1/230/60	1/115/60	1/230/60	
Nominal Voltage Consumption	A	2,5	1,1	2,6	1,2	2,7	1,2	3,2	1,6	3,4	1,7	5,1	2,7	
Conductor	mm²	1,5	1,5	1,5	1,5	1,5	1,5	2,5	1,5	2,5	1,5	2,5	1,5	
Maximum Distance Voltage Drop (2%)	m	24	112	23	103	23	103	32	77	30	73	20	46	
Power consumption	kW	0,19	0,19	0,20	0,20	0,21	0,21	0,29	0,29	0,30	0,30	0,45	0,50	
Refrigerant Fluid	Type	R134a												
 Fittings	NPT-F	3/8"					1/2"					1"		
 Dimensions pol. (mm)	A - Height	17.1/8" (435)					18.11/16" (475)					29.1/8" (740)		
	L - Width	12.3/16" (305)					14.9/16" (370)					13.9/16" (345)		
	C - Length	14.9/16" (345)					20.1/4" (515)					16.9/16" (420)		
Dew point	°F (°C)	41 (5)*												
 Temperature Environment °F (°C)	Máx.	113 (45)												
	Mín.	34 (1)												
 Net weight	lb (Kg)	46 (21)			48 (22)		55 (25)		62 (28)		70 (32)		75 (34)	

MODELO ADS		100	125	150	175	220	300	375	480								
Flow	scfm	100	125	150	175	220	300	375	480								
	ℓ /min	2830	3538	4245	4953	6226	8490	10613	13584								
	m³/h	170	212	255	297	374	509	637	815								
 Nominal inlet air pressure	barg/psig	100 (7)															
 Maxima inlet air pressure	barg/psig	203 (14)															
Electric Voltage	V	1/115/60	1/230/60	1/115/60	1/230/60	1/115/60	1/230/60	1/230/60									
Nominal Voltage Consumption	A	8,0	4,0	7,6	4,4	7,7	4,5	7,7	4,9	5,2	5,9	9,1	9,4				
Conductor	mm²	2,5	1,5	4,0	1,5	4,0	1,5	4,0	1,5	1,5	2,5	4,0	4,0				
Maximum Distance Voltage Drop (2%)	m	17	31	21	28	21	27	21	25	23	35	36	35				
Power consumption	kW	0,70	0,70	1,00	1,05	1,05	1,15	1,10	1,20	1,25	1,50	2,20	2,30				
Refrigerant Fluid	Type	R134a				R407C											
 Fittings	NPT-F	1.1/4"				1.1/2"			2"		2.1/2"						
 Dimensions pol. (mm)	A - Height	29.1/8" (740)			32.7/16" (825)		34.13/16" (885)		38.3/8" (975)		43.1/2" (1105)						
	L - Width	13.9/16" (345)			19.2/16" (485)		21.7/8" (555)		21.7/8" (555)		26.3/16" (665)						
	C - Length	17.1/2" (445)			17.15/16" (455)		22.13/16" (580)		24.5/8" (625)		28.9/16" (725)						
Dew point	°F (°C)	41 (5)*															
 Temperature Environment °F (°C)	Máx.	113 (45)															
	Mín.	34 (1)															
 Net weight	lb (Kg)	86 (39)		88 (40)		110 (50)		119 (54)		123 (56)		207 (94)		212 (96)		317 (144)	

(*) The nominal condition refers to an ambient temperature of 100°F (38°C) with inlet air at 100psig (7barg) and 100°F (38°C).

(2) Check the data shown on the identification plate.

TABLE 6.1 – TECHNICAL DATA ADS

7. CORRECTION FACTORS

Where applicable, it should be used correction factors to keep the performance of the dryer.

Correction factor for operating pressure changes:									
Inlet air pressure	psig	60	80	100	120	140	160	180	203
	barg	4	5.5	7	8	10	11	12	14
Factor (F1)		0.79	0.91	1.00	1.07	1.13	1.18	1.23	1.27

Correction factor for ambient temperature changes:								
Ambient temperature	°F	≤ 80	90	95	100	105	110	115
	°C	≤ 27	32	35	38	40	43	45
Factor (F2)		1.10	1.07	1.04	1.00	0.93	0.83	0.70

Correction factor for inlet air temperature changes:						
Air temperature	°F	≤ 90	100	110	122	130
	°C	≤ 32	38	43	50	55
Factor (F3)		1.11	1.00	0.80	0.65	0.53

Correction factor for DewPoint changes:					
DewPoint	°F	38	41	45	50
	°C	3	5	7	10
Factor (F4)		0.92	1.00	1.7	1.25

How to find the air flow capacity:	
Air flow capacity = Nominal duty x Factor (F1) x Factor (F2) x Factor (F3) x Factor (F4)	
Example: An ADS 75 has a nominal duty of 75 scfm (127 m ³ /h). What is the maximum allowable flow through the dryer under the following operating conditions:	
Inlet air pressure = 120 psig (8 barg)	Factor (F1) = 1.07
Ambient temperature = 105°F (40°C)	Factor (F2) = 0.93
Inlet air temperature = 122°F (50°C)	Factor (F3) = 0.65
Pressure DewPoint = 50°F (10°C)	Factor (F4) = 1.25
Each item of data has a corresponding numerical factor which multiplied by the design air flow is as follows:	
Air flow capacity = 75 x 1.07 x 0.93 x 0.65 x 1.25 = 61 scfm (104 m ³ /h)	
61 scfm (104 m ³ /h) This is the maximum flow rate that the dryer can accept under these operating conditions.	

How to select a suitable dryer for a given duty:	
Minimum std. air flow rate =	$\frac{\text{Design air flow}}{\text{Factor (F1) x Factor (F2) x Factor (F3) x Factor (F4)}}$
Example: With the following operating parameters:	
Design air flow = 100 scfm (170 m ³ /h)	Factor (F1) = 1.07
Inlet air pressure = 120 psig (8 barg)	Factor (F2) = 0.93
Ambient temperature = 105°F (40°C)	Factor (F3) = 0.65
Inlet air temperature = 122°F (50°C)	Factor (F4) = 1.25
Pressure DewPoint = 50°F (10°C)	
In order to select the correct dryer model the required flow rate is to be divided by the correction factors relating to above mentioned parameters:	
Minimum std. air flow rate =	$\frac{100}{1.07 \times 0.93 \times 0.65 \times 1.25} = 124 \text{ scfm (211 m}^3\text{/h)}$
Therefore the model suitable for the conditions above is ADS 125 (125 scfm [212 m ³ /h] - nominal duty).	

8. INSTALLATION

1. Location

The product must be installed in an engine room according to NR13 of MTb, in a roofed area that is well ventilated, free from dust, toxic gases, humidity or pollution of any kind. In order to reduce the excess of noise, a soundproofing project must be taken into consideration. Failure to install dryer in the proper ambient conditions will affect the dryer's ability to condense refrigerant gas. This can cause higher loads on the compressor, loss of dryer efficiency and performance, overheated condenser fan motors, electrical component failure and dryer failure due to the following: compressor loss, fan motor failure and electrical component failure. Failures of this type will affect warranty considerations.

If the room temperature is over that, it is necessary to use the flow correction table. This applies factors which help to find out the corrected discharge the dryer is able to process. The use of exhaust fans is also recommended, cooling ducts, or other means to provide a decrease in temperature.

If the room temperature is near or less than 5°C, the SRS - Air Dryer is not recommended, as heating is required for the machine room and the entire compressed air pipeline for temperatures around or over 10°C. The presence of contamination agents (dust, fibers, etc.) suspended in the air can cause premature obstruction of the condenser (See the chapter on Preventive Maintenance).

2. Placement

Notice the recommended distance in Illustration 8.1, away from any obstacle to avoid harming the operation and at the same time facilitating preventive maintenance of the ADS - Air Dryer.

Dryers models ADS 10 – 150 can be wall-mounted. See fixing dimensions on dimensional drawings in the attachment section.

The hanging mounting inevitably causes the obstruction of the ventilation grid positioned on the panel facing the wall fixing. This obstruction, in any case, does not prejudice the efficiency of the ventilation inside the dryer which is guaranteed by other grids on the other panels.

ADS – Air Dryers are supplied with feminine flanges, gauges as shown on Table Technical Specifications.

Do not use a reduction fitting on the outlet of the ADS - Air Dryer, or install undersized line filter(s) so that there is no loss of pressure near the air production source. Whenever possible install "Y" connectors instead of "T" connectors and long-radius bend connectors.

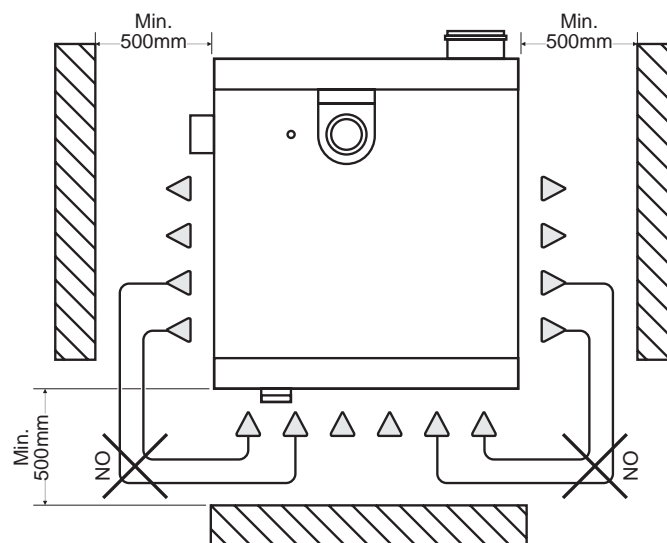

FIGURE 8.1 – MINIMUM DISTANCES FROM WALL AND CEILING (OR ANY OTHER OBSTACLE) THE PRODUCT MUST BE INSTALLED TO GUARANTEE NECESSARY VENTILATION CONDITIONS

3. Foundation

The product must be installed on a concrete base capable of supporting its weight and the forces resulting from its operation. Install the ADS - Air Dryer by removing the base used for shipping.

4. Compressed air quality

The installation of a coalescent filter of 1 μ (micron) is indispensable in the ADS - Air Dryer inlet for the purpose of avoiding the entrance of oil and solid particles which may obstruct or harm the thermal exchange in the heat exchanger. If the air processed by the dryer is supplied by an Alternating Piston Compressor a total pipeline course of at least 8 meters is recommended between the reservoir and the dryer (or a coalescent pre-filter). This length of pipeline helps a great deal in cooling the compressed air before going into the dryer.

It depends on the quality of the compressed air to evaluate the need of installing one or more filters. The purpose is to avoid the accumulation of particles in the line. It is recommended to install coalescent filters to comply with the ISO 8573 Standard (Illustration 8.1).

ISO 8573.1 – QUALITY CLASSES			
QUALITY CLASSES	PARTICLE SIZE IN MICRONS	WATER P.O. °C E 7 barg	OIL INCLUDING VAPOR mg/m ³
1	0,1	-70	0,01
2	1	-40	0,1
3	5	-20	1,0
4	15	+3	5
5	40	+7	25
6	-	+10	-
7	-	-	-

TABLE 9.1 – QUALITY CLASSES OF COMPRESSED AIR

In short pipelines, it is always convenient to install a reservoir with at least 1/5 of the compressed air volume produced by the compressor (measure the flow in liters/minute for the installed compressor). It is strongly recommended to install the reservoir before the Air Dryer to avoid flooding the dryer from the condensed water coming from the air compressor, which can overload the operating capacity of the equipment.

In a good compressed air network project, it requires the installation of a reservoir/condensate separator to absorb the pulsations generated through sudden consumption and strategically maintain a reserve supply to protect against consumption peaks.

We recommend installing in the compressor outlet or in the compressed air line, a derivation with a hose and spray nozzle for cleaning the condenser and other maintenance jobs required as the need arises at the compressed air installation site.

4.1 Connection to the compressed air system



The user is responsible to ensure that the dryer will never be operated with pressure exceeding the maximum pressure rating on the unit data tag.

Over-pressurizing the dryer could be dangerous for both the operator and the unit.

The air temperature and the flow entering the dryer must comply within the limits stated on the data nameplate. The system connecting piping must be kept free from dust, rust, chips and other impurities, and must be consistent with the flow-rate of the dryer. In case of treatment of air at particularly high temperature, the installation of a final refrigerator could result necessary. In order to perform maintenance operations, it is recommended to install a dryer by-pass system.



In case of heavily polluted inlet air (ISO 8573.1 class 3.-.3 or worse quality), we recommend the additional installation of a pre-filter (5 micron minimum) to prevent a clogging of the heat exchanger.

In realising the dryer, particular measures have been taken in order to limit the vibration which could occur during the operation. Therefore we recommend to use connecting pipes able to insulate the dryer from possible vibrations originating from the line (flexible hoses, vibration damping fittings, etc.).



IMPORTANT

Piping the dryer, inlet/outlet connections must be supported as shown in the diagram.



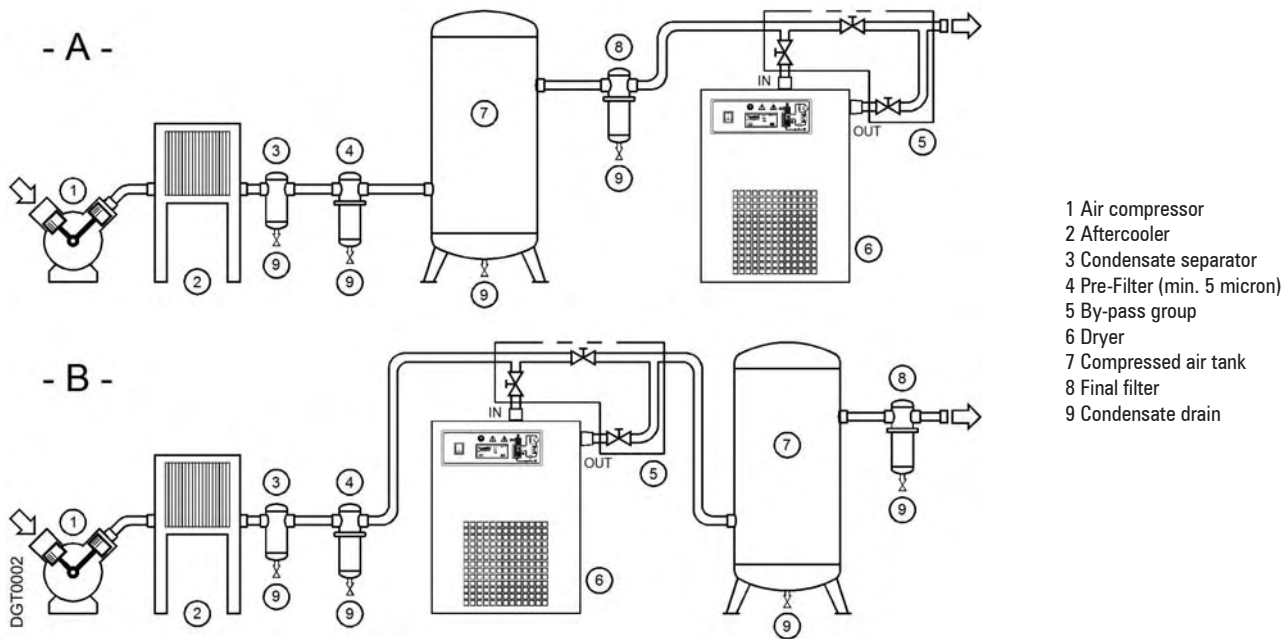

FIGURE 8.1 – A TYPICAL INSTALLATION OF COMPRESSED AIR TREATMENT

Type A installation is suggested when the compressor operates at reduced intermittence and the total consumption equals the compressor flow rate.

Type B installation is suggested when the air consumption can consistently change with peak values highly exceeding the flow rate of the compressors. The capacity of the tank must be sized in order to compensate eventual instantaneous demanding conditions (peak air consumption).

5. Electrical Hookups

Consult with a specialized technician to evaluate the overall conditions of the electrical network and select adequate protective power supply devices.



Before connecting the unit to the electrical supply, verify the data nameplate for the proper electrical information. Voltage tolerance is +/- 10%. Dryer are supplied with power cord and plug (two poles and ground) or with a junction box.

Be sure to provide the proper fuses or breakers based on the data information located on the nameplate.

The mains socket must be provided with a mains magneto-thermal differential breaker ($I\Delta n = 0.03A$), adjusted on the basis of the consumption of the dryer (see the nominal values on the data plate of the dryer). The cross section of the power supply cables must comply with the consumption of the dryer, while keeping into account also the ambient temperature, the conditions of the mains installation, the length of the cables, and the requirements enforced by the local Power Provider.



Important: ensure that the dryer is earthed.

Do not use any socket adapters at the mains plug.

If the mains plug needs to be replaced, this must only be done by a qualified electrician.

6. Condensate drain



The condensate is discharge at the system pressure.



Drain line should be secured.

Never point the condensate drain line towards anybody.

The dryer comes already fitted with a timed condensate drainer (solenoid valve controlled by electronic instrument) or with an electronic condensate drainer (optional).

Connect and properly fasten the condensate drain to a collecting plant or container.

The drain cannot be connected to pressurized systems.

Don't dispose the condensate in the environment.

The condensate collected in the dryer contains oil particles released in the air by the compressor.

Dispose the condensate in compliance with the local rules.

We recommend to install a water-oil separator where to convey all the condensate drain coming from compressors, dryers, tanks, filters, etc.

9. INSTRUMENT PANEL

9.1 Control panel

The control panel illustrated below is the only dryer-operator interface.

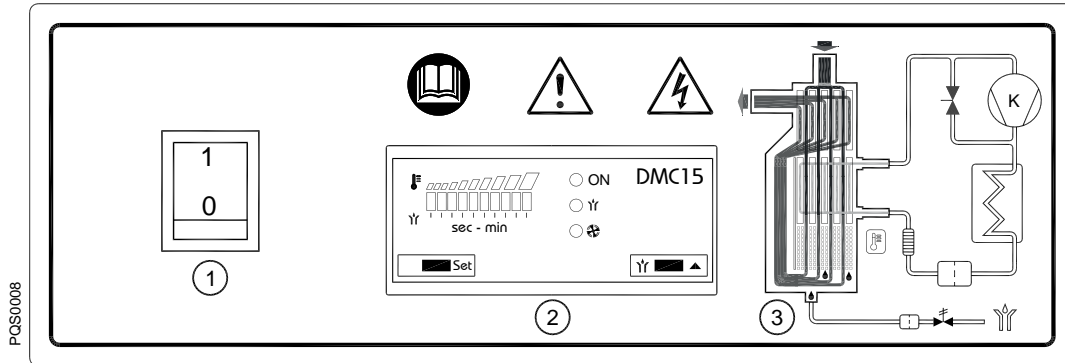

FIGURE 9.1 - ADS 10 - 175

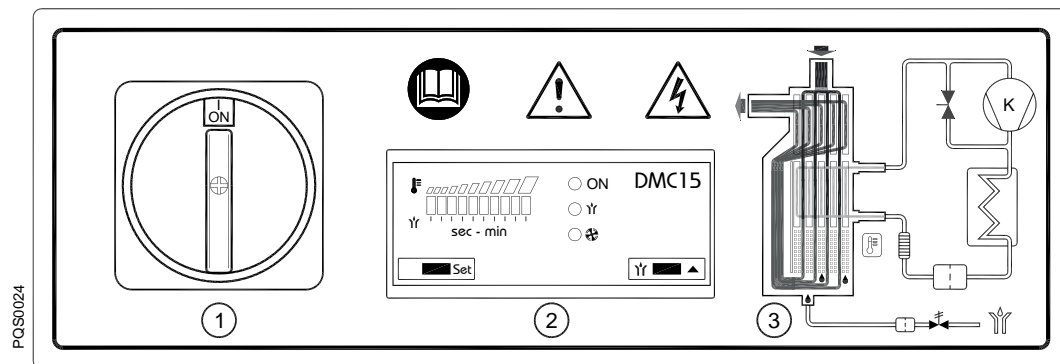

FIGURE 9.2 - ADS 220 - 480

1. ON-OFF Switch
2. Electronic instrument
3. Air and refrigerant flow diagram

9.2 Operation

Operating principle - The dryer models described in this manual operate all on the same principle. The hot moisture laden air enters an air to air heat exchanger. The air then goes through the evaporator, also known as the air to refrigerant heat exchanger. The temperature of the air is reduced to approximately 36°F (2°C), causing water vapor to condense to liquid. The liquid is continuously coalesced and collected in the separator for removal by the condensate drain. The cool moisture free air then passes back through the air to air heat exchanger to be reheated to within 8 degrees of the incoming air temperature as it exits the dryer.

Refrigerant circuit - Refrigerant gas is cycled through the compressor and exits at high pressure to a condenser where heat is removed causing the refrigerant to condense to a high-pressure liquid state. The liquid is forced through a capillary tube where the resulting pressure drop allows the refrigerant to boil off at a predetermined temperature. Low-pressure liquid refrigerant enters the heat exchanger where heat from the incoming air is transferred causing the refrigerant to boil; the resulting phase change produces a low pressure, low temperature gas. The low-pressure gas is returned to the compressor, where it is re-compressed and begins the cycle again. During those periods when the compressed air load is reduced the excess refrigerant is by-passed automatically back to the compressor via the hot gas by-pass valve circuit.

9.3 Flow diagram

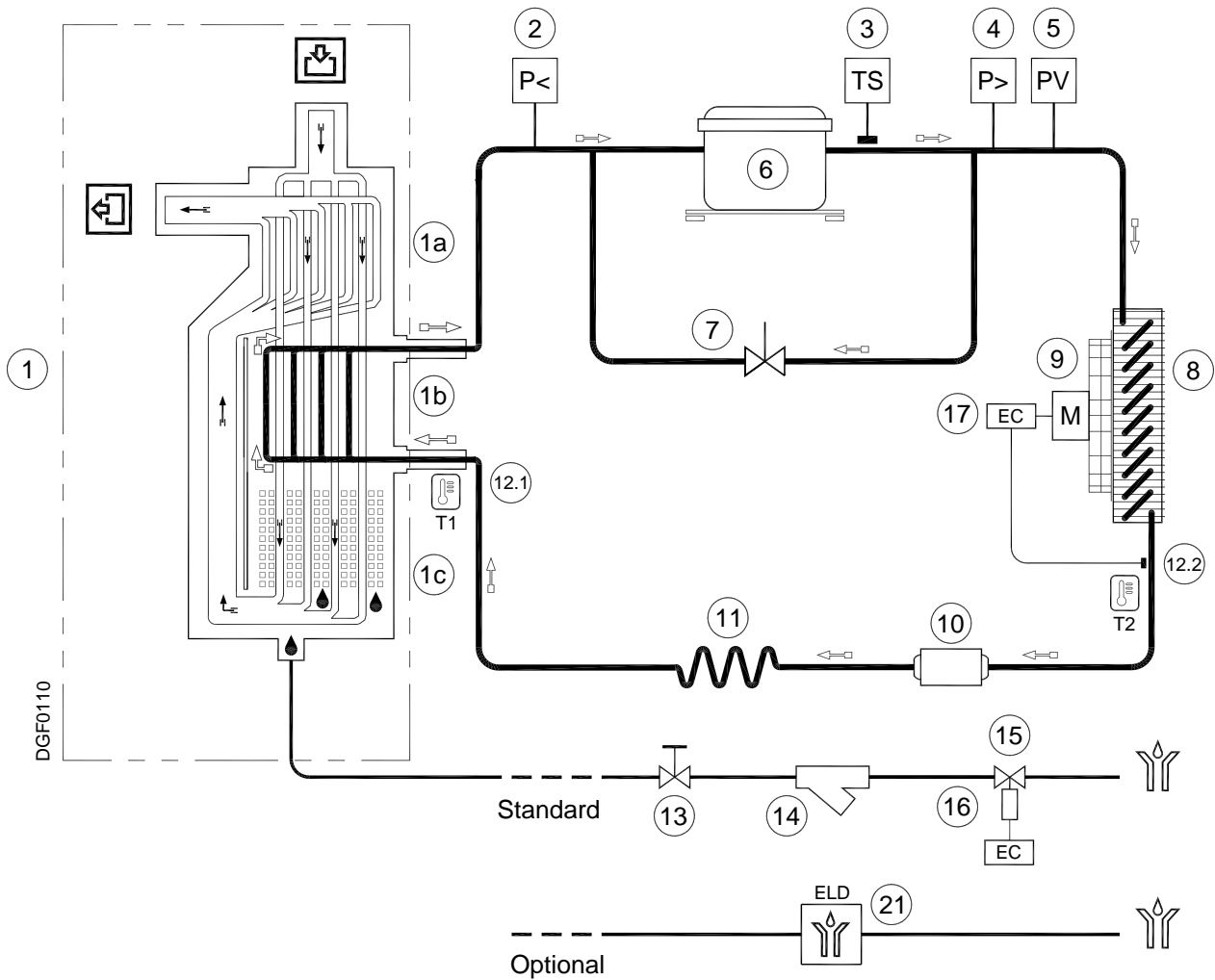

FIGURE 9.3

- 1. Alu-Dry module
 - 1a. Air-to-air heat exchanger
 - 1b. Air-to-refrigerant heat exchanger
 - 1c. Condensate separator
 - 2. Refrigerant pressure switch LPS (ADS 480)
 - 3. Safety thermo switch TS (ADS 220-480)
 - 4. Refrigerant pressure switch HPS (ADS 300-480)
 - 5. Refrigerant pressure switch PV (ADS 125-480)
 - 6. Compressor
 - 7. Hot gas by-pass valve
 - 8. Condenser
 - 9. Condenser fan
 - 10. Filter dryer
 - 11. Capillary tube
 - 12.1 Temperature probe T1 – DewPoint
 - 12.2 Temperature probe T2 – Fan control (ADS 10-100)
 - 13. Condensate drain service valve
 - 14. Condensate drain strainer
 - 15. Condensate drain solenoid valve
 - 16. Coil for condensate drain solenoid valve
 - 17. Electronic instrument
 - 21. Electronic drainer
- ➡ Compressed air flow direction
 ⇨ Refrigerant gas flow direction

9.4 Refrigerating compressor

The refrigerating compressor is the pump in the system, gas coming from the evaporator (low pressure side) is compressed up to the condensation pressure (high pressure side). The compressors utilized are manufactured by leading manufacturers and are designed for applications where high compression ratios and wide temperature changes are present.

The hermetically sealed construction is perfectly gas tight, ensuring high-energy efficiency and long, useful life. Dumping springs support the pumping unit in order to reduce the acoustic emission and the vibration diffusion. The aspirated refrigerant gas, flowing through the coils before reaching the compression cylinders cools the electric motor. The thermal protection protects the compressor from over heating and over currents. The protection is automatically restored as soon as the nominal temperature conditions are reached.

9.5 Condenser

The condenser is the component in which the gas coming from the compressor is cooled down and condensed becoming a liquid. Mechanically, a serpentine copper tubing circuit (with the gas flowing inside) is encapsulated in an aluminum fin package.

The cooling operation occurs via a high efficiency fan, creating airflow within the dryer, moving air through the fin package. It's mandatory that the ambient air temperature does not exceed the nominal values. It is also important to keep the condenser unit free from dust and other impurities

9.6 Filter dryer

Traces of humidity and slag can accumulate inside the refrigerant circuit. Long periods of use can also produce sludge. This can limit the lubrication efficiency of the compressor and clog the expansion valve or capillary tube. The function of the filter drier, located before the capillary tubing, is to eliminate any impurities from circulating through the system.

9.7 Capillary tube

It consists of a piece of reduced cross section copper tubing located between the condenser and the evaporator, acting as a metering device to reduce the pressure of the refrigerant. Reduction of pressure is a design function to achieve optimum temperature reached within the evaporator: the smaller the capillary tube outlet pressure, the lower the evaporation temperature.

The length and interior diameter of the capillary tubing is accurately sized to establish the performance of the dryer; no maintenance or adjustment is necessary.

9.8 Alu-Dry module

The heat exchanger module houses the air-to-air, the air-to-refrigerant heat exchangers and the demister type condensate separator. The counter flow of compressed air in the air-to-air heat exchanger ensures maximum heat transfer. The generous cross section of flow channel within the heat exchanger module leads to low velocities and reduced power requirements. The generous dimensions of the air-to-refrigerant heat exchanger plus the counter flow gas flow allows full and complete evaporation of the refrigerant (preventing liquid return to the compressor). The high efficiency condensate separator is located within the heat exchanger module. No maintenance is required and the coalescing effect results in a high degree of moisture separation.

9.9 Hot gas by-pass valve

This valve injects part of the hot gas (taken from the discharge side of the compressor) in the pipe between the evaporator and the suction side of the compressor, keeping the evaporation temperature/pressure constant at approx. +36°F (+2°C). This injection prevents the formation of ice inside the dryer evaporator at every load condition.

Adjustment

The hot gas by-pass valve is adjusted during the manufacturing testing phase. As a rule no adjustment is required; anyway if it is necessary the operation must be carried out by an experienced refrigerating engineer.

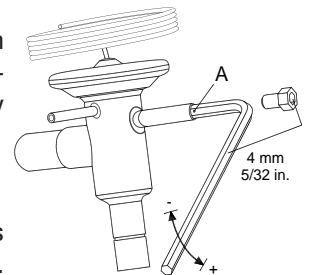

ATTENTION

the use of 1/4" Schrader service valves must be justified by a real malfunction of the refrigerating system. Each time a pressure gauge is connected, a part of refrigerant is exhausted.

Without compressed air flow through the dryer, rotate the adjusting screw (position A on the drawing) until the following value is reached:

Hot gas setting :

R134.a pressure 29.0 psig (+ 1.45 / -0 psi) [2.0 barg (+0.1 / -0 bar)]

R407C pressure 65.3 psig (+1.45 / -0 psi) [4.5 barg (+0.1 / -0 bar)]

9.10 Refrigerant pressure switches LPS – HPS – PV

As operation safety and protection of the dryer a series of pressure switches are installed in the gas circuit.

LPS : Low-pressure protection device on the suction side of the compressor, trips if the pressure drops below the pre-set value. The values are automatically reset when the nominal conditions are restored.

Calibrated pressure :

R 134.a Stop 10.2 psig (0.7 barg) - Restart 24.7 psig (1.7 barg)

R 407 C Stop 24.7 psig (1.7 barg) - Restart 53.7 psig (3.7 barg)

HPS : This high-pressure controller device, located on the discharge side on the compressor, is activated when the pressure exceeds the pre-set value. It features a manual-resetting button mounted on the controller itself.

Calibrated pressure :

R 134.a Stop 290 psig (20 barg) - Manual reset P<203 psi (P<14 bar)

R 407 C Stop 435 psig (30 barg) - Manual reset P<334 psi (P<23 bar)

PV :Fan control pressure switch located at the discharge side of compressor. It keeps the condensing temperature/pressure constant within preset limits.

Calibrated pressure :

R 134.a Start 160 psig (+7.25 / -0 psi) [11 barg (+0.5 / -0 bar)]

Stop 116 psig (+0 / -7.25 psi) [8 barg (+0 / -0.5 bar)]

R 407 C Start 261 psig (+7.25 / -0 psi) [18 barg (+0.5 / -0 bar)]

Stop 203 psig (+0 / -7.25 psi) [14 barg (+0 / -0.5 bar)]

9.11 Safety thermo switch TS

To protect the operating safety and the integrity of the dryer, a thermo switch (TS) is installed on the refrigerant gas circuit. The thermo switch sensor, in case of unusual discharge temperatures, stops the refrigerating compressor before it is permanently damaged.

Manually reset the thermo switch only after the nominal operating conditions have been restored. Unscrew the relative cap (see position 1 in the figure) and press the reset button (see position 2 in the figure).

TS setting : temperature 235,4°F (113°C) (+0 / -6 °K)

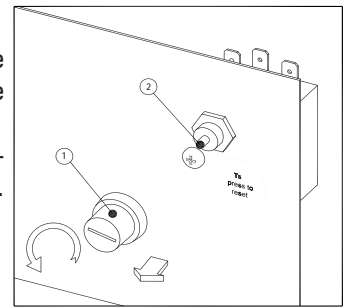

9.12 Electronic instrument DMC15

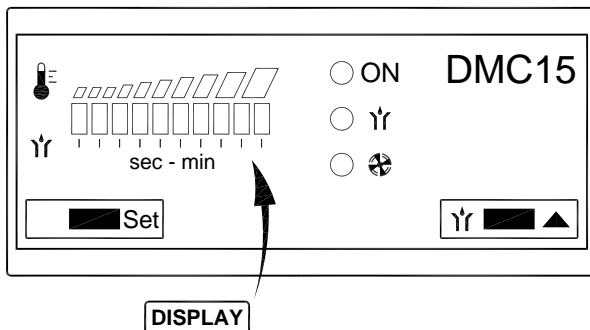

- ON Led – Power ON
- ȳ Led - Drain ON
- ⚙ Led – Condenser fan ON (ADS 10-100)
- Set Button – Setup menu access
- ȳ ■ ▲ Button – Increase / Drain test

The DMC15 displays DewPoint temperature, controls the condenser fan activation and the timed drainer.

9.12.1 How to switch on the dryer

Power the dryer and switch it on using the ON-OFF switch (position1 paragraph 9.1).

During normal operation led is ON and the display shows the DewPoint temperature by means of two coloured areas (green and red) above a 10 Led display :

- Green area - operating conditions ensuring an optimal DewPoint;
- Red area - DewPoint too high, the dryer is operating with high thermal load (high inlet air temperature, high ambient temperature, etc.). Compressed air treatment may be improper.

Led ○ ON shows that condensate drain solenoid valve is ON.

Led ○ ⚙ shows that condenser fan is ON (ADS 10-100).

The condensate drain test is always active using the button ȳ ■ ▲

9.12.2 How to switch off the dryer

Switch it off using the ON-OFF switch (position 1 paragraph 9.1).

9.12.3 How a service warning / alarm is displayed

A service warning / alarm is an unusual event that must recall the attention of the operators / maintenance technicians. It does not stop the dryer.

Service warnings / alarms are automatically reset as soon as the problem is solved.

NOTE: the operator / maintenance technician must inspect the dryer and verify / solve the problem that generated the service warning.





Service Warning / Alarm	Description
Display 1st (left) and 10th (right) led are flashing	Failure T1 (DewPoint) temperature probe.
Led   is flashing	(ADS 10-100) Failure T2 (fan control) temperature probe. NOTE : fan is forced always ON.
Display 10th (right) led is flashing	DewPoint too high
Display 1st (left) led is flashing	DewPoint too low (lower than -1°C / 30°F).

TABLE 9.1



9.12.4 How is controlled the condenser fan (ADS 10-100)

A temperature probe T2 is located on the discharge side of the condenser. The condenser fan is activated (ON) when the T2 temperature is higher than FANon setting (standard 35°C / 96°F) and led   is ON.

Condenser fan stops at T2 temperatures 5°C / 10°F lower than FANon setting (standard 30°C / 86°F).

9.12.5 How is controlled the drain solenoid valve

Drain solenoid valve is activated (ON) for Ton seconds (standard 2 seconds) every Toff minutes (standard 1 minute).

Led   shows that condensate drain solenoid valve is ON.

The condensate drain test is always active using the button .

9.12.6 How to change the operating parameters – SETUP menu

The setup menu can be used to change the dryer's operating parameters.



Only qualified personnel must be allowed to access to the setup menu. The manufacturer is not responsible for malfunctioning or failure due to modification to the operating parameters.

With dryer ON press button  for at least 3 seconds to enter the setup menu.

Access to the menu is confirmed by led  ON and  flashing (first parameter of menu).

Keep  pressed and use arrows  to change the value. Release the button  to confirm the value.

Press shortly  to skip to following parameter.

Press  to exit setup menu (if no button is pressed after 2 minutes the menu is exited automatically).







Display	Description	Limits	Resolution	Standard setup
Synchronous flashing led  + led 	(ADS 10-100) FANon : condenser fan activation (ON) temperature	31 ... 40°C or 88 ... 104°F	1°C or 2°F	35 or 96
Synchronous flashing led  + led 	Ton – drain time ON : time ON condensate drain valve	1 ... 10 seg.	1 sec.	2
Non-Synchronous flashing led  + led 	ToF - drain time OFF : pause time for condensate drain valve	1 ... 10 min.	1 min.	1

TABLE 9.2

NOTE : parameter values are displayed on the 10 led display where 1st (left) led is the lowest limit and 10th (right) is the highest limit.

9.13 Electronic drainer (optional)

Instead of the usual drain system (a solenoid valve controlled by means of electronic instrument); an electronic level controlled drainer can be installed as option. This drainer consists of a condensate accumulator where a capacitive sensor continuously checking liquid level is placed: as soon as the accumulator is filled, the sensor passes a signal to the electronic control and a diaphragm solenoid valve will open to discharge the condensate. For a complete condensate discharge the valve opening time will be adjusted exactly for each single drain operation. No condensate strainers are installed. No adjusting is required. A service valve is installed before the electronic drain in order to make check and maintenance easily. At dryer start-up verify that this valve is open.

Control panel for dryers ADS 10 – 300

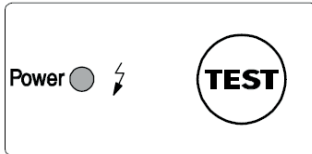

Power Led On - drainer ready to work / supplied
TEST Button Discharge test (keep pushed for 2 seconds)

Control panel for dryers ADS 375 – 480

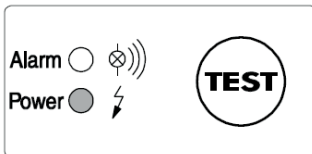

Power Led On - drainer ready to work / supplied
Alarm Led Blinking - drainer in alarm condition
TEST Button Discharge test (keep pushed for 2 seconds)

10. OPERATION

1. Preliminary operation



Verify that the operating parameters match with the nominal values stated on the data nameplate of the dryer (voltage, frequency, air pressure, air temperature, ambient temperature, etc.).

This dryer has been thoroughly tested, packaged and inspected prior to shipment. Nevertheless, the unit could be damaged during transportation, check the integrity of the dryer during first start-up and monitor operation during the first hours of operation.



Qualified personnel must perform the first start-up.

When installing and operating this equipment, comply with all National Electrical Code and any applicable federal, state and local codes.

Who is operating the unit is responsible for the proper and safe operation of the dryer.

Never operate equipment with panels removed.

2. First start-up

This procedure should be followed on first start-up, after periods of extended shutdown or following maintenance procedures. Qualified personnel must perform the start-up.

Sequence of operations (refer to paragraph 9.1 Control Panel).

- Ensure that all the steps of the "Installation" chapter have been observed.
- Ensure that the connection to the compressed air system is correct and that the piping is suitably fixed and supported.
- Ensure that the condensate drain pipe is properly fastened and connected to a collection system or container.
- Ensure that the by-pass system (if installed) is closed and the dryer is isolated.
- Ensure that the manual valve of the condensate drain circuit is open.
- Remove any packaging and other material which could obstruct the area around the dryer.
- Activate the mains switch.
- Turn ON the switch - position 1 on the control panel.
- Ensure that electronic instrument is ON.
- Ensure the consumption matches with the values of the data plate.
- Ensure the fan works properly – wait for its first interventions.
- Allow the dryer temperature to stabilise at the pre-set value.
- Slowly open the air inlet valve.
- Slowly open the air outlet valve.
- Slowly close the central by-pass valve of the system (if installed).
- Check the piping for air leakage.
- Ensure the drain is regularly cycling - wait for its first interventions.

3. Start-up and shut down

Start-up (refer to paragraph Control Panel)

- Check the condenser for cleanliness.
- Turn ON the switch - position 1 on the control panel.
- Ensure that electronic instrument is ON.
- Wait a few minutes; verify that the DewPoint temperature displayed on electronic instrument is correct and that the condensate is regularly drained.
- Switch on the air compressor.

Shut down (refer to paragraph Control Panel)

- Check that the DewPoint temperature indicated on the electronic instrument is within range.
- Shut down the air compressor.
- After a few minutes, turn OFF the switch - pos. 1 on the control panel.

NOTE: A DewPoint included in the green operating area of the electronic controller is correct according to the possible working conditions (flow-rate, temperature of the incoming air, ambient temperature, etc.)

During the operation, the refrigerant compressor will run continuously. The dryer must remain on during the full usage period of the compressed air, even if the air compressor works intermittently.

The number of starts must be no more than 6 per hour.



The dryer must stop running for at least 5 minutes before being started up again.

Frequent starts may cause irreparable damage.

The user is responsible for compliance with these rules.

11. PREVENTIVE MAINTENANCE

Only qualified personnel should perform troubleshooting and or maintenance operations.

Prior to performing any maintenance or service, be sure that :

- No part of the machine is powered and that it cannot be connected to the mains supply.
- No part of the machine is under pressure and that it cannot be connected to the compressed air system.
- Maintenance personnel have read and understand the safety and operation instructions in this manual.



Before attempting any maintenance operation on the dryer, shut it down and wait at least 30 minutes. Some components can reach high temperature during operation. Avoid contact until system or component has dissipated heat.

Daily

- Verify that the DewPoint displayed on the electronic instrument is correct.
- Check the proper operation of the condensate drain systems.
- Verify the condenser for cleanliness.

Every 200 hours or monthly

- With an air jet (max. 2 bar / 30 psig) blowing from inside towards outside clean the condenser; repeat this operation blowing in the opposite way; be careful not to damage the aluminum fins of the cooling package.
- Close the manual condensate drain valve, unscrew the strainer (if installed) and clean it with compressed air and brush. Reinstall the strainer properly tight, and then open the manual valve.
- At the end, check the operation of the machine

Every 1000 hours or yearly

- Verify for tightness all the screws of the electric system and that all the "Disconnects-Tabs" type connections are in their proper position inspect unit for broken, cracked or bare wires.
- Inspect refrigerating circuit for signs of oil and refrigerant leakage.
- Measure and record amperage. Verify that readings are within acceptable parameters as listed in specification table.
- Inspect flexible hoses, and replace if necessary.

Every 8000 hours

- Replace Electronic drainer service unit

Maintenance operation on the refrigeration circuit



Maintenance and service on refrigerating systems must be carried out only by certified refrigerating engineers only, according to local rules. All the refrigerant of the system must be recovered for its recycling, reclamation or destruction.

Do not dispose the refrigerant fluid in the environment.

This dryer comes ready to operate and filled with R134a or R407C type refrigerant fluid.

In case of refrigerant leak contact a certified refrigerating engineer. Room is to be aired before any intervention.

If is required to re-fill the refrigerating circuit, contact a certified refrigerating engineers.

Refer to the dryer nameplate for refrigerant type and quantity.

Refrigerant	Chemical formula	TLV	GWP
R134a - HFC	CH ₂ FCF ₃	1000 ppm	1300
R407C - HFC	R32/125/134a (23/25/52) CHF ₂ CF ₃ /CH ₂ F ₂ /CH ₂ FCF ₃	1000 ppm	1653

TABLE 11.1

Dismantling of the dryer

If the dryer is to be dismantled, it has to be split into homogeneous groups of materials.

Part	Material
Refrigerant fluid	R407C, R134a, Oil
Canopy and Supports	Carbon steel, Epoxy paint
Refrigerating compressor	Steel, Copper, Aluminium, Oil
Alu-Dry Module	Aluminium
Condenser Unit	Aluminium, Copper, Carbon steel
Pipe	Copper
Fan	Aluminium, Copper, Steel
Valve	Brass, Steel
Electronic Level Drain	PVC, Aluminium, Steel
Insulation Material	Synthetic rubber without CFC, Polystyrene, Polyurethane
Electric cable	Copper, PVC
Electric Parts	PVC, Copper, Brass

TABLE 11.2

We recommend to comply with the safety rules in force for the disposal of each type of material.

Refrigerant contains droplets of lubrication oil released by the refrigerating compressor.

Do not dispose this fluid in the environment. It has to be discharged from the dryer with a suitable device and then delivered to a collection centre where it will be processed to make it reusable.

11.1 Spare parts

The suggested spare parts list will enable you to promptly intervene in case of abnormal operation, so avoiding to wait for the spares delivery. In case of failure of other parts, for example inside the refrigerating circuit, the replacement must be worked out by a refrigerating systems specialist or in our factory.

NOTE: To order the suggested spare parts or any other part, it's necessary to quote the data reported on the identification plate.



IMPORTANT

Check the dryer drain and the coalescent filter operation.

(1) For Coalescent Filters installed in the compressed air network (in compliance with manufacturer instructions).

(2) The cleaning period can be anticipated or prolonged based on the existent contaminants in the ADS - Air Dryer equipment installation location conditions.

* Use as a reference the scroll compressor hour meter whenever installed together with piston compressors to monitor maintenance procedures.

12. REMOVING MAINTENANCE PARTS - DISPOSAL

When the SRS - Air Dryer coalescent filters have been operated, installed by customer, in compliance to current local standards; they must be disposed of.

See additional guidance of "Recommended Environmental Guidance".

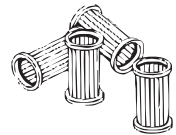

13. CORRECTIVE MAINTENANCE



ATTENTION

To guarantee the SAFETY and RELIABILITY of the product, the repairs, maintenance and adjustments must be performed through the nearest SCHULZ AUTHORIZED DEALER, which always uses genuine parts.

15. ENVIRONMENTAL GUIDELINES AND RECOMMENDATIONS

1. Disposal of Liquid Waste

The presence of liquid or condensed water not treated of reservoir or condensate separator in rivers, lakes or other receiving means can affect adversely the aquatic life and the quality of the water.

The condensate removed daily from the reservoir or condensate separator, according to Chapter "Preventive Maintenance", should be collected in recipient and/or in collector lines adapted for its posterior treatment.

Schulz S.A. recommends to treat appropriately the liquid waste produced inside the reservoir of SRS - Air Dryer or from the condensate separator through processes that seek to guarantee the protection to the environment and the life quality of the population in conformity with the requirements of the country-specific regulations.

It can be used several treatment methods such as physical-chemical, chemical and biological.

The treatment can be made by the own company or through the service of third parts.

2. Disposal of Solid Waste (parts in general and product package)

The generation of solid residues is an aspect that should be considered by user, in the use and maintenance of its equipment. The impacts caused in the environment can provoke significant alterations in the quality of the ground, in the quality of the superficial water and the underground and in the health of the population, through the inadequate disposal of the discarded residues (in public roads, hydric receivers, sanitary embankments, etc.).

Schulz S.A. recommends the residues handling originating from the product since its generation, handling, movement, treatment until its final disposal. An appropriate handling should consider the following stages: quantification, qualification, classification, reduction in the source, collecting and selective collecting, recycling, storage, transport, treatment and final destination.



The solid residues disposal should be done in agreement with the requirements of the country-specific regulations.

14. FAILURE DIAGNOSTICS

The purpose of this list of procedures is to simulate the most common problems and possible causes which may cause downtime or improper operation of your ADS - Air Dryer Schulz.

The simplicity of some procedures for troubleshooting provides the means for the user to solve some of them without the interaction of specialized Technical Assistance. Therefore, if problems persist after applying the listed corrective actions, get in touch with technical assistance from an accredited Schulz Authorized-Technical/Distributor for this equipment.

EVENTUAL DEFECT		PROBABLE CAUSE - SUGGESTED ACTION
Electronic Drain	No led lighting up.	<ul style="list-style-type: none"> Verify that the system is powered. Verify the electric wiring (internal and/or external). Check internal printed circuit board for possible damage.
	Pressing of Test button, but no condensate discharge.	<ul style="list-style-type: none"> The service valve located before the drain is closed - open it. The dryer is not under pressure - restore nominal condition. Solenoid valve defective - replace the drain. The internal printed circuit board is damaged - replace the drain.
	Condensate discharge only when Test button is pressed.	<ul style="list-style-type: none"> Condensate discharge only when Test button is pressed.
	Drain keeps blowing off air.	<ul style="list-style-type: none"> The diaphragm valve is dirty - open the drain and clean it. The capacitive sensor is too dirty - open the drain and clean the sensor plastic tube.
	Drain in alarm condition.	<ul style="list-style-type: none"> The capacitive sensor is too dirty - open the drain and clean the sensor plastic tube. The service valve located before the drain is closed - open it. The dryer is not under pressure - restore nominal condition. Solenoid valve defective - replace the drain.
Dryer	The dryer doesn't start.	<ul style="list-style-type: none"> Verify that the system is powered. Verify the electric wiring.
	The compressor doesn't work.	<ul style="list-style-type: none"> Activation of the compressor internal thermal protection - wait for 30 minutes, then retry. Verify the electric wiring. If installed - Replace the internal thermal protection and/or the start-up relay and/or the start-up capacitor and/or the working capacitor. If installed - The pressure switch HPS has been activated - see specific point. If installed - The pressure switch LPS has been activated - see specific point. If installed - The safety thermo switch TS has been activated - see specific point If the compressor still doesn't work, replace it.
	Condenser's fan doesn't work.	<ul style="list-style-type: none"> Verify the electric wiring. ADS 10-100 - The DMC15 electronic instrument is faulty – replace it. ADS 125-480 - PV pressure switch is faulty – replace it There is a leak in the refrigerant circuit - contact a refrigeration engineer. If the fan still doesn't work, replace it.
	DewPoint too high.	<ul style="list-style-type: none"> The dryer doesn't start - see specific point. The DewPoint probe T1 doesn't correctly detect the temperature - ensure the sensor is pushed into the bottom of probe well. The Compressor doesn't work - see specific point. The ambient temperature is too high or the room aeration is insufficient - provide proper ventilation. The inlet air is too hot - restore nominal conditions. The inlet air pressure is too low - restore nominal conditions. The inlet air flow rate is higher than the rate of the dryer - reduce the flow rate - restore nominal conditions. The condenser is dirty - clean it. The condenser fan doesn't work - see specific point. The dryer doesn't drain the condensate - see specific point. The hot gas by-pass valve is out of setting - contact a refrigeration engineer to restore nominal setting. There is a leak in the refrigerant circuit - contact a refrigeration engineer.
	Dew Point too low	<ul style="list-style-type: none"> ADS 10-100 - The fan is always ON - the  yellow LED of DMC15 electronic instrument is flashing - see specific point. ADS 125-480 - The fan is always on – PV pressure switch is faulty – replace it. Ambient temperature is too low - restore nominal conditions. The hot gas by-pass valve is out of setting - contact a refrigeration engineer to restore nominal setting.
	Excessive pressure drop within the dryer.	<ul style="list-style-type: none"> The dryer doesn't drain the condensate - see specific point. The DewPoint is too low - the condensate is frost and blocks the air - see specific point. Check for throttling the flexible connection hoses.

Dryer	The dryer doesn't drain the condensate	<ul style="list-style-type: none"> The condensate drain service valve is closed - open it. Condensate strainer is clogged – remove and clean it. The drain solenoid valve is jammed – remove and clean it. Verify the electric wiring. The coil of the drain solenoid valve is failed – replace it. Electronic instrument is faulty – replace it. The DewPoint is too low - the condensate is frost and blocks the air - see specific point. Inlet compressed air pressure is too low and condensate is not drained – restore nominal conditions. Electronic drainer is not operating correctly (see paragraph 9.13).
	The dryer continuously drains condensate.	<ul style="list-style-type: none"> The drain solenoid valve is jammed – remove and clean it. Try to remove the electric connector on the solenoid valve - if drain stops verify the electric wiring or the electronic instrument is faulty - replace it Electronic drainer is dirty (see paragraph 9.13).
	Water within the line.	<ul style="list-style-type: none"> The dryer doesn't start - see specific point. If installed - Untreated air flows through the by-pass unit - close the by-pass. The dryer doesn't drain the condensate - see specific point. DewPoint too high - see specific point.
	If installed - HPS high pressure switch has been activated.	<ul style="list-style-type: none"> Check which of the following has caused the activation : 1. The ambient temperature is too high or the room aeration is insufficient - provide proper ventilation. 2. The condenser is dirty - clean it. 3. The condenser fan doesn't work - see specific point. Reset the pressure switch pressing the button on the controller itself - verify the dryer for correct operation. HPS pressure switch is faulty - contact a refrigeration engineer to replace it.
	If installed - LPS low pressure switch has been activated.	<ul style="list-style-type: none"> There is a leak in the refrigerating fluid circuit - contact a refrigeration engineer. The pressure switch reset automatically when normal conditions are restored - check the proper operation of the dryer.
	If installed - TS safety thermo switch has been activated.	<ul style="list-style-type: none"> Check which of the following has caused the activation : 1. Excessive thermal load – restore the standard operating conditions. 2. The inlet air is too hot - restore the nominal conditions. 3. The ambient temperature is too high or the room aeration is insufficient - provide proper ventilation. 4. The condenser unit is dirty - clean it. 5. The fan doesn't work - see specific point. 6. The hot gas by-pass valve requires re-adjusting – contact a specialized technician to restore nominal setting. 7. Refrigerant gas leak - contact a refrigeration engineer. Reset the thermo switch by pressing the button on the thermo switch itself – verify the correct operation of the dryer. TS thermo switch is faulty - replace it.
	Electronic instrument DMC15 The first and the last led of display are flashing synchronous.	<ul style="list-style-type: none"> Verify the electric wiring of T1 DewPoint probe. The T1 DewPoint probe is faulty - replace it. The electronic instrument is faulty - replace it.
	Electronic instrument DMC15 The   yellow led is flashing	<ul style="list-style-type: none"> ADS 10-100 - Verify the electric wiring of T2 fan control probe. ADS 10-100 - The T2 fan control probe is faulty - replace it. ADS 125-480 - Verify the electric wiring of resistance on terminal 1 and 2 The electronic instrument is faulty - replace it.
	Electronic instrument DMC15 The first led of the display is flashin	<ul style="list-style-type: none"> DewPoint too low - see specific point. The T1 DewPoint probe is faulty - replace it. The electronic instrument is faulty - replace it.
Electronic instrument DMC15 The last led of the display is flashing	<ul style="list-style-type: none"> DewPoint too high - see specific point. The T1 DewPoint probe is faulty - replace it. The electronic instrument is faulty - replace it. 	

NOTE: When the drain is in alarm condition, the diaphragm solenoid valve will open 7.5 sec every 4 min.

16. WARRANTY

The "Manufacturer" warrants this equipment to the original purchaser against manufacturing defects of the compressor/dryer for a period of one year and two years (including the Legal Warranty – first 90 (ninety) days) for the air end and the heat exchanger of the dryer, from the date of the issue of the invoice, conditioned on the technical start (when applied) carried out by SCHULZ AUTHORIZED DEALER, subject to the purchase period of the invoice.

The warranty will be granted to the compressor unit provided that:

- A. Periodicity is observed for the exchange of lubricating oil (Air end), and given installation conditions as instructed in this manual.
- B. The lubricant oil used is oil for rotary screw air compressor recommended in this Manual (Air End), and the spare parts used are genuine SCHULZ parts.
- C. The compressor will not operate without the filters or being damaged/clogged to the point of losing its filtering normal capacity.

WARRANTY GENERAL CONDITIONS

- A. The warranty period elapses from the purchase date of the product and not from the technical start (when applied).
- B. Possible shutdown of the equipment, regardless of the reason, will not generate the right to compensation, repair, refund or return of any nature.
- C. Warranty reception will only be held by SCHULZ AUTHORIZED DEALER in view of presentation of the original invoice, preferably on behalf of the customer, containing Tax ID.
- D. It is not included in the warranty: parts that naturally wear out with regular use and that are influenced by installation and way of use of the product, such as: air filter, oil filter, valves, hoses, bearings, pressure gauges, fan of the frequency inverter, rotary shaft seal, oil level sight, ball valve, contactors, electronic sensors, electronic interface, air/oil separator element and lubricant oil.
- E. Warranty will not include installation and cleaning services, bearing relubrication, adjustments requested by the customer, change of lubricant oil and filters, damages to the external part of the product as well as damages that may result from improper use, neglect, modifications, external agents, bad weather, use of improper accessories, bad dimensioning for the applications it is intended to, falls, perforations, operation different from the directions of the Instruction Manual, power connections to improper voltages or to power lines subject to excessive variations, overloads or fuel use (portable compressors) of poor quality.
- F. The warranty of the motor (electric and diesel) and of the component parts of the electric panel (electric switch) is subject to surety and issue of a technical report provided by their manufacturer which informs defects in material and workmanship.
- G. The power voltage of the command must operate within the variation of $\pm 10\%$ (Electronic Interface).
- H. Any repairs or compensation for damages caused during transportation are not covered by the warranty.
- I. The warranty will not include modifications in the parameters of the Electronic Interface, unless directed by SCHULZ AUTHORIZED DEALER. SCHULZ S.A. will not be liable for failures in the compressor, halts or damages due to the not following of this recommendations/conditions listed in this manual.

WARRANTY EXTINCTION

This warranty will have no effect when:

- A. As of the standard course of its expiration date, counted from the issue date of the invoice.
- B. The product is sent for repair or moved (except portable) to another place by people/companies not authorized by SCHULZ S.A., and presents signs of violation of its original characteristics or assembling out of the factory standards.
- C. Allow the air dryer to operate without the coalescing pre-filter, according to ISO 8573.1, class 1.4.1, or damaged to the point of losing its normal filtering capacity, or even when its service term is expired.

NOTES

- A. The lubrication of the compressor is essential, which, to have a correct operation and long useful life, also needs oil change and elements of the preventive maintenance at regular intervals as indicated in this manual.
- B. No SCHULZ retailer, representative or SCHULZ AUTHORIZED DEALER is authorized to change, add, delete, modify this Warranty or take liabilities on behalf of Schulz S.A.
- C. Compressors that may be without running (off, dead, with missing parts, etc.) during the period exceeding 6 (six) months should receive preventive maintenance before operating. The expenses from this maintenance are the customer's responsibility.
- D. The drawings, dimensions and photos contained in this manual are for illustrative purposes.

Note: 1. Schulz S.A. reserves the right of making changes in this Instruction Manual without any previous notice.



2. The product lines Compact, Portable and Dryers do not include technical start.

17. SERVICE REPORT

To facilitate preventive and corrective maintenance controls, and periodic inspections, use the following template: Service Report, for filling in data on the equipment sale and data sheet on maintenance services.

Dryer model	Serial number	
Reseller	Invoice number	Date
Start-up Date		
Optional equipment		

Notes

Date	Operating Hours	Room Temperature	Electronic Controller Temperature	Services: (change coalescent element, tighten electrical, connections, overall cleaning, etc.)	 	Comments	Signature

Esquemas elétricos | Esquemas de conexiones | Electric diagrams

TAC	Descrição Descripción Description
L1	Condutor fase Conductor de fase
N	Condutor neutro Conductor neutro
PE	Condutor de proteção/aterramento Conductor de protección/conexión a tierra
S1	Botão liga/desliga Botón de encendido/apagado
MC1	Motor-compressor hermético Hermética motocompresor
ELD	Purgador eletrônico Purgador electrónico
MV1	Motor-ventilador Motor-ventilador
EVD	Válvula solenóide do dreno de condensado Válvula de solenoide de la fuga de condensado
BT1/BTI	Sensor de temperatura do ponto de orvalho Punto de rocío Sensor de temperatura
BT2	Sensor de temperatura do ventilador Sensor de temperatura del fan
DMC15	Controlador eletrônico do secador Controlador electrónico del secador
TS	Sensor de temperatura Sensor de temperatura
PV	Pressostato do ventilador Presostato del fan
HPS	Pressostato de pressão de alta Pressostato de alta presión
LPS	Pressostato de pressão de baixa Pressostato de baja presión

ID N.		Descrição peças de reposição Descripción de los repuestos Description	Código Part number	ADS - UP													
				10	15	20	35	50	75	100	125	150	175				
5	PV	Pressostato gás refrigerante Presóstato gás frigorígeno Pressure switch	5655NNN160										1	1	1		
6	MC	Compressor frigorífico Compressor frigorífico Compressor	5015135101	1	1	1											
			5015135105				1	1									
			5015135010						1								
			5015135011							1							
			5030135005										1	1	1		
7		Válvula de by-pass gás quente Válvula de by-pass gás caliente Hot gas by-pass valve	64140SS160	1	1	1	1	1	1	1							
			64140SS151										1	1	1		
9.1	MV	Motor ventilador Motor del ventilador Fan motor	5210135021												1		
			5210135005	1	1	1	1										
			5210135010						1	1							
			5210135015								1						
			5210135030										1			1	
9.2		Ventoinha do ventilador Impulsor del ventilador Fan blade	5215000010	1	1	1	1										
			5215000019					1	1								
			5215000022							1							
			5215000023										1				
			5215000025											1	1		
9.3		Grade do ventilador Rejilla del ventilador Fan grid	5225000010					1	1	1	1						
			5225000027											1	1		
10		Filtro desidratador Filtro deshidratador Filter drier	6650SSS007	1	1	1	1	1	1	1							
			6650SSN150										1	1	1		
12	BT	Sonda de temperatura Temperature probe	5625NNN035	2	2	2	2	2	2	2	2	1	1	1	1		
13-14		Válvula/Filtro descarga de condensação Válvula/Filtro descarga de condensação Condensate drain valve/strainer	64355MN012	1	1	1	1	1	1	1	1	1	1				
14		Filtro tipo "Y" descarga de condensação Filtro tipo "Y" descarga de condensação Y strainer	64355FF011												1		
15	EVD	Eletroválvula Electroválvula Condensate drain solenoid valve	64320FF081	1	1	1	1	1	1	1	1						
			64320FF083											1	1	1	
16		Bobina eléctrica descarga condensação Bobina eléctrica descarga condensado Coil for condensate drain solenoid valve	64N22MM002	1	1	1	1	1	1	1	1						
			64N22MM004											1	1	1	
17	DMC 15	Instrumento eletrónico Instrumento electrónico Electronic instrument	5620130104	1	1	1	1	1	1	1	1	1	1	1	1		
21	ELD	Descarregador eletrónico Interruptor luminoso Electronic drainer	2210BEK001J	1	1	1	1	1	1	1	1	1	1	1	1		
		Unidade de serviço para descarreg. eletrónico Unidad de servicio del descargador electrónico Service unit for electronic drainer	2210BEK057	1	1	1	1	1	1	1	1	1	1	1	1		
22	S1	Interruptor iluminado Interruptor luminoso Lighted switch	5450SZN010	1	1	1	1	1	1	1	1	1	1	1	1		
		Cobertura para interruptor iluminado Cobertura del interruptor luminoso Cover for lighted switch	5450SZN015	1	1	1	1	1	1	1	1	1	1	1	1		

ID N.	Descrição peças de reposição Descripción de los repuestos Description	Código Part number	ADS - UE																	
			10	15	20	35	50	75	100	125	150	175	220	300	375	480				
2	LPS	Pressostato gás refrigerante Presóstato gás frigorígeno <i>Pressure switch</i>	5655NNN085															1		
3	TS	Termostato de segurança Termostato de seguridad <i>Safety thermo switch</i>	56141NN000											1	1	1	1			
4	HPS	Pressostato gás refrigerante Presóstato gás frigorígeno <i>Pressure switch</i>	5655NNN087													1	1	1		
5	PV	Pressostato gás refrigerante Presóstato gás frigorígeno <i>Pressure switch</i>	5655NNN160								1	1	1	1						
			5655NNN170													1	1	1		
6	MC	Compressor frigorífico Compresor frigorífico <i>Compressor</i>	5015110101	1	1	1														
			5015110107				1	1												
			5015110117						1											
			5015115011							1										
			5030115005								1	1	1							
			5030115015												1	1				
7		Válvula de by-pass gás quente Válvula de by-pass gas caliente <i>Hot gas by-pass valve</i>	64140SS160	1	1	1	1	1	1	1										
			64140SS151									1	1	1	1	1	1	1	1	1
9	MV	Ventilador completo <i>Complete fan</i>	5250370001													1	1	1		
9.1	MV	Motor do ventilador Motor del ventilador <i>Fan motor</i>	5210110018									1								
			5210115000	1	1	1	1													
			5210115001					1	1											
			5210115015							1										
			5210115002									1		1						
			5210115020												1					
9.2		Ventoinha do ventilador Impulsor del ventilador <i>Fan blade</i>	5215000010	1	1	1	1													
			5215000019					1	1											
			5215000022							1										
			5215000023									1								
			5215000025										1	1						
9.3		Grade do ventilador Rejilla del ventilador <i>Fan grid</i>	5225000010					1	1	1	1									
			5225000027										1	1	1					
10		Filtro desidratador Filtro deshidratador <i>Filter drier</i>	6650SSS007	1	1	1	1	1	1	1										
			6650SSN150									1	1	1						
			6650SSN160												1	1	1	1	1	
12	BT	Sonda de temperatura <i>Temperature probe</i>	5625NNN035	2	2	2	2	2	2	2	1	1	1	1	1	1	1	1		
13-14		Válvula/Filtro descarga de condensação Válvula/Filtro descarga vapor condensado <i>Condensate drain valve/strainer</i>	64355MN012	1	1	1	1	1	1	1	1	1								
14		Filtro tipo "Y" descarga de condensação Filtro en "Y" descarga vapor condensado <i>Y strainer</i>	64355FF011										1	1	1	1	1	1		
15	EVD	Eletroválvula descarga de condensação Electroválvula descarga vapor condensado <i>Condensate drain solenoid valve</i>	64320FF080	1	1	1	1	1	1	1										
			64320FF082									1	1	1	1	1	1	1	1	1
16		Bobina eléctrica descarga de condensação Bobina eléctrica descarga vapor condensado <i>Coil for condensate drain solenoid valve</i>	64N22MM001	1	1	1	1	1	1	1										
			64N22MM003									1	1	1	1	1	1	1	1	1
17	DMC15	Instrumento eletrónico Instrumento electrónico <i>Electronic instrument</i>	5620110104	1	1	1	1	1	1	1	1	1	1	1	1	1	1	1		
21	ELD	Descarregador eletrónico Descargador electrónico <i>Electronic drainer</i>	2210BEK001J	1	1	1	1	1	1	1	1	1	1	1	1	1				
			2210BEK002J																1	1
		Unidade de serviço para dreño eletrónico Unidad de servicio para descargador electrónico <i>Electronic drainer</i>	2210BEK057	1	1	1	1	1	1	1	1	1	1	1	1	1	1			
			2210BEK058																1	1
22	S1	Interruptor iluminado Interruptor luminoso <i>Lighted switch</i>	5450SZN010	1	1	1	1	1	1	1	1	1	1							
		Cobertura para interruptor iluminado Cobertura del interruptor luminoso <i>Cover for lighted switch</i>	5450SZN015	1	1	1	1	1	1	1	1	1	1							
	QS	Secionador Geral Seccionador general <i>Main switch</i>	54505ZN140											1	1	1	1	1		

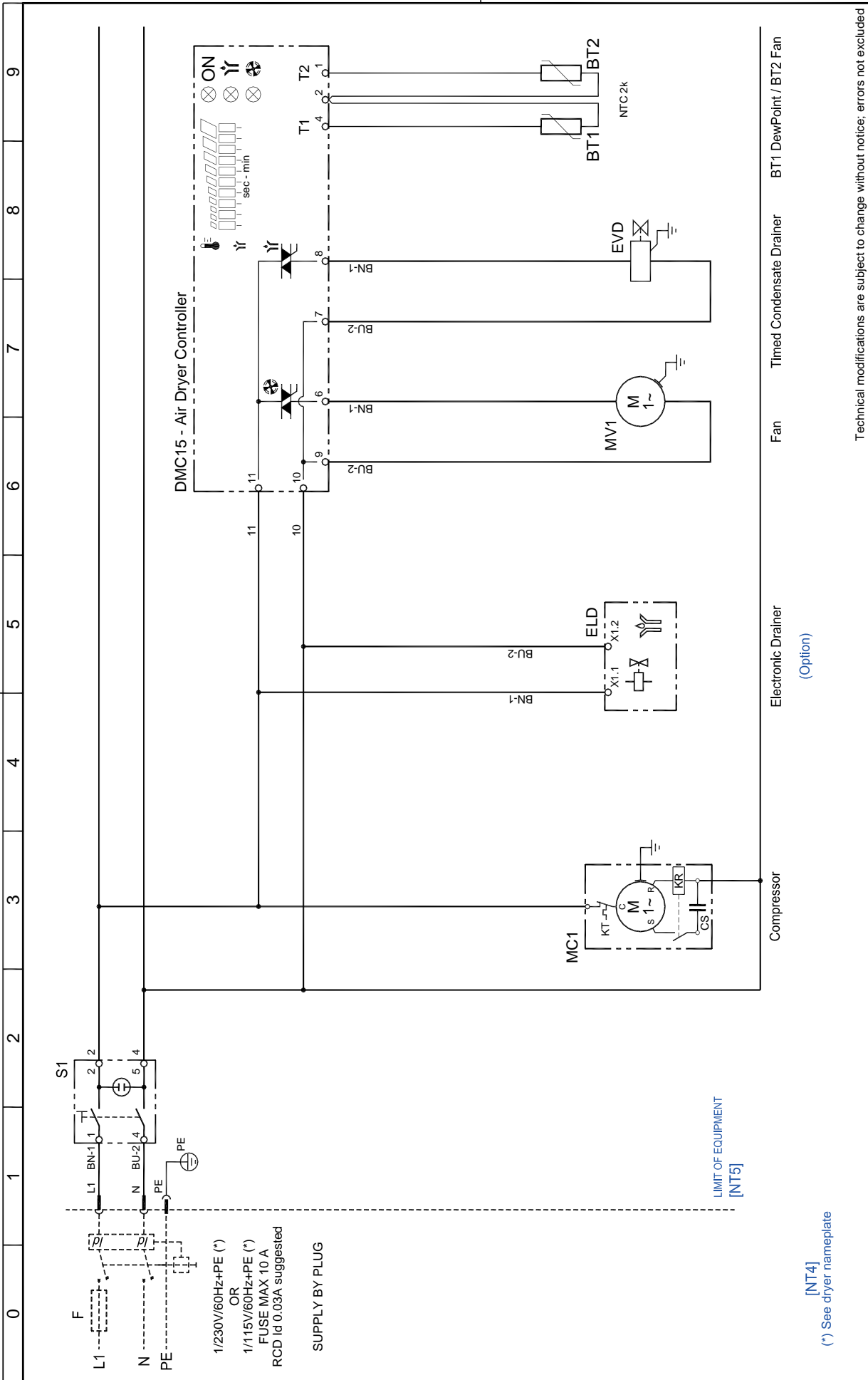

Technical modifications are subject to change without notice; errors not excluded

Drawing no. : **FRAMD-USEL0137**

Rev. **01**

Note : .

Sheet **01** of **01**

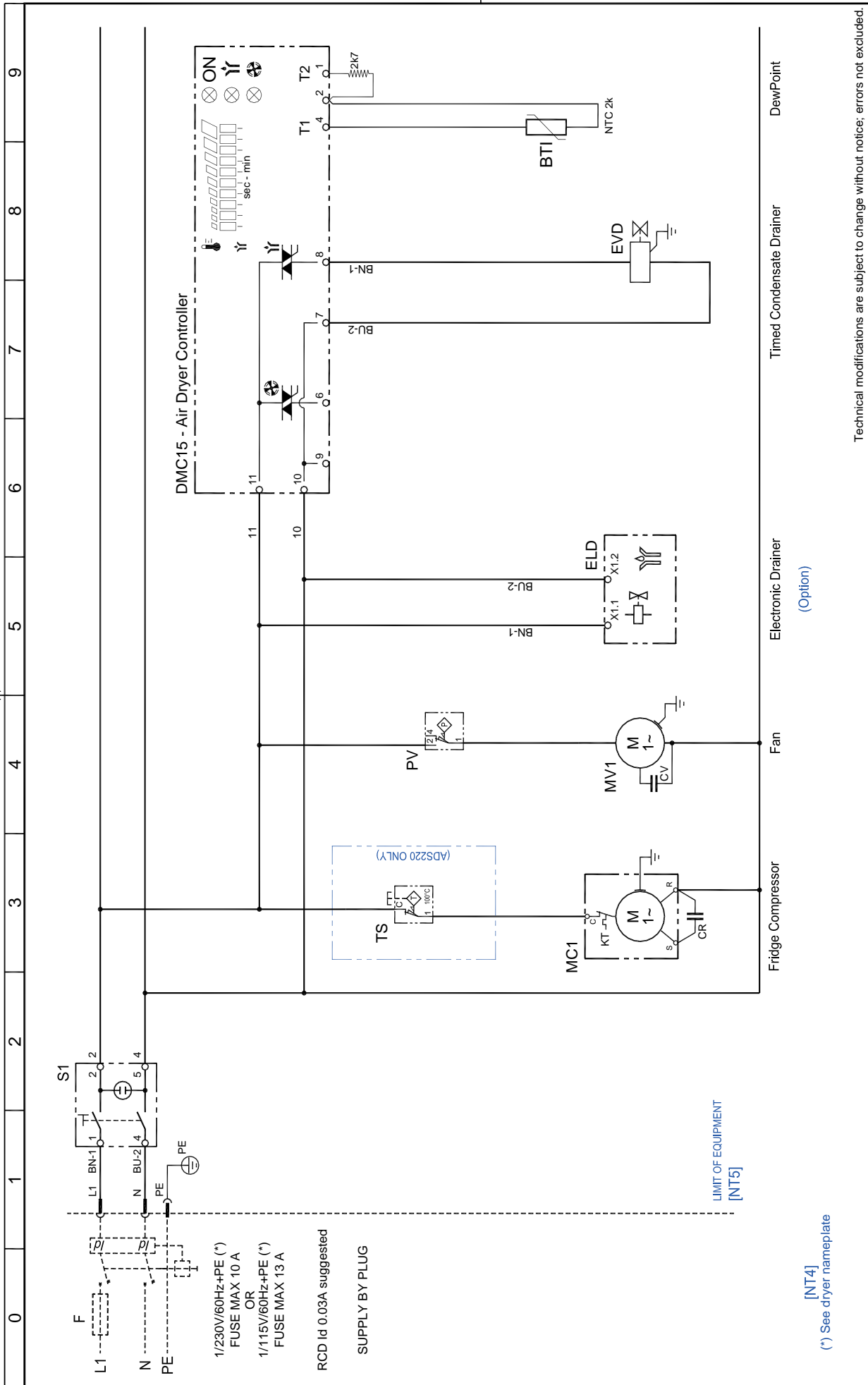

Technical modifications are subject to change without notice; errors not excluded.

Rev.

Drawing no. :

SCADS-USEL0138

01

Note :

Sheet 01 of 01

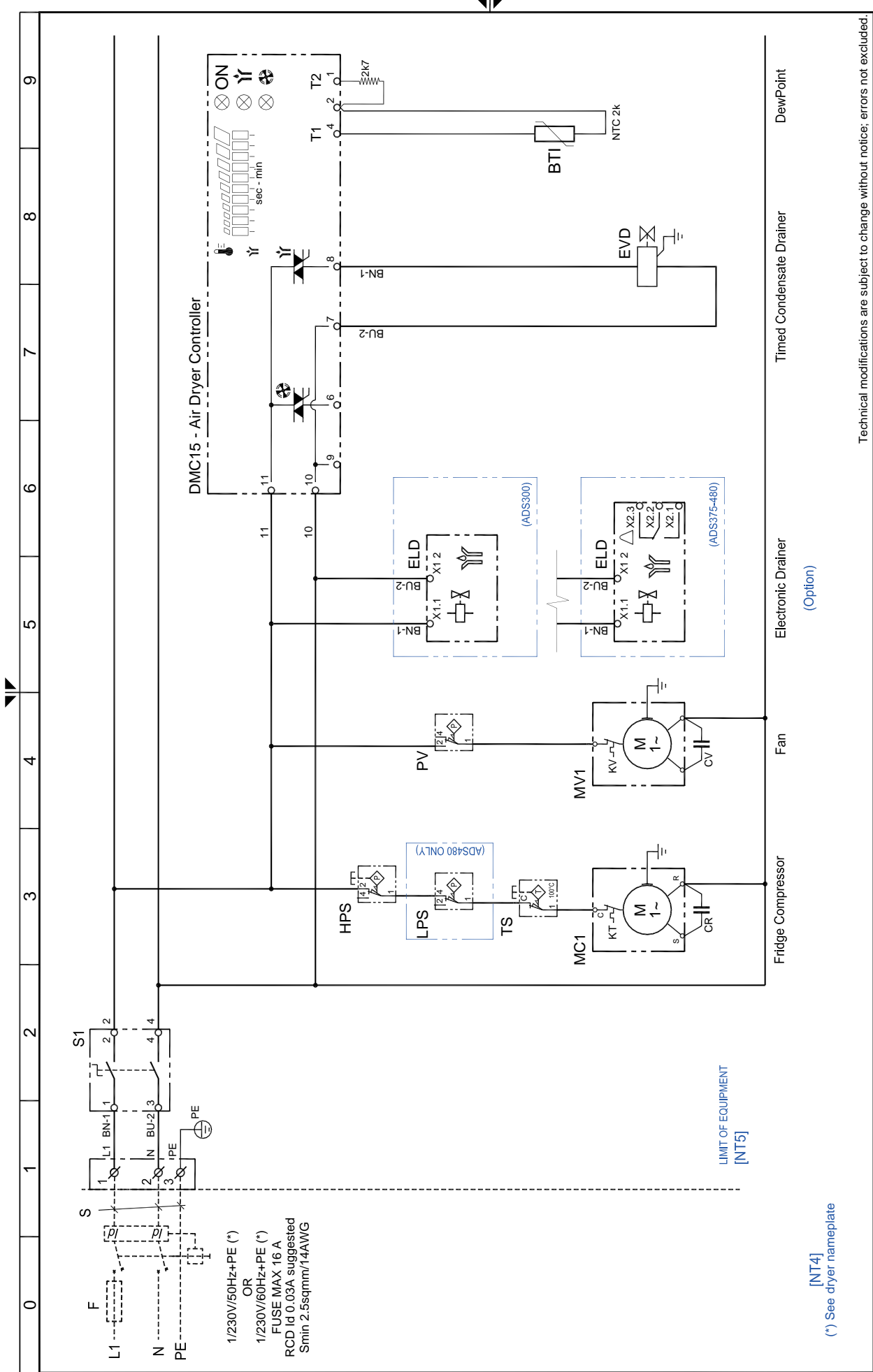

Technical modifications are subject to change without notice; errors not excluded.

Drawing no. : SCADS-USEL0139

Rev. 01

Note : -

Sheet 01 of 01

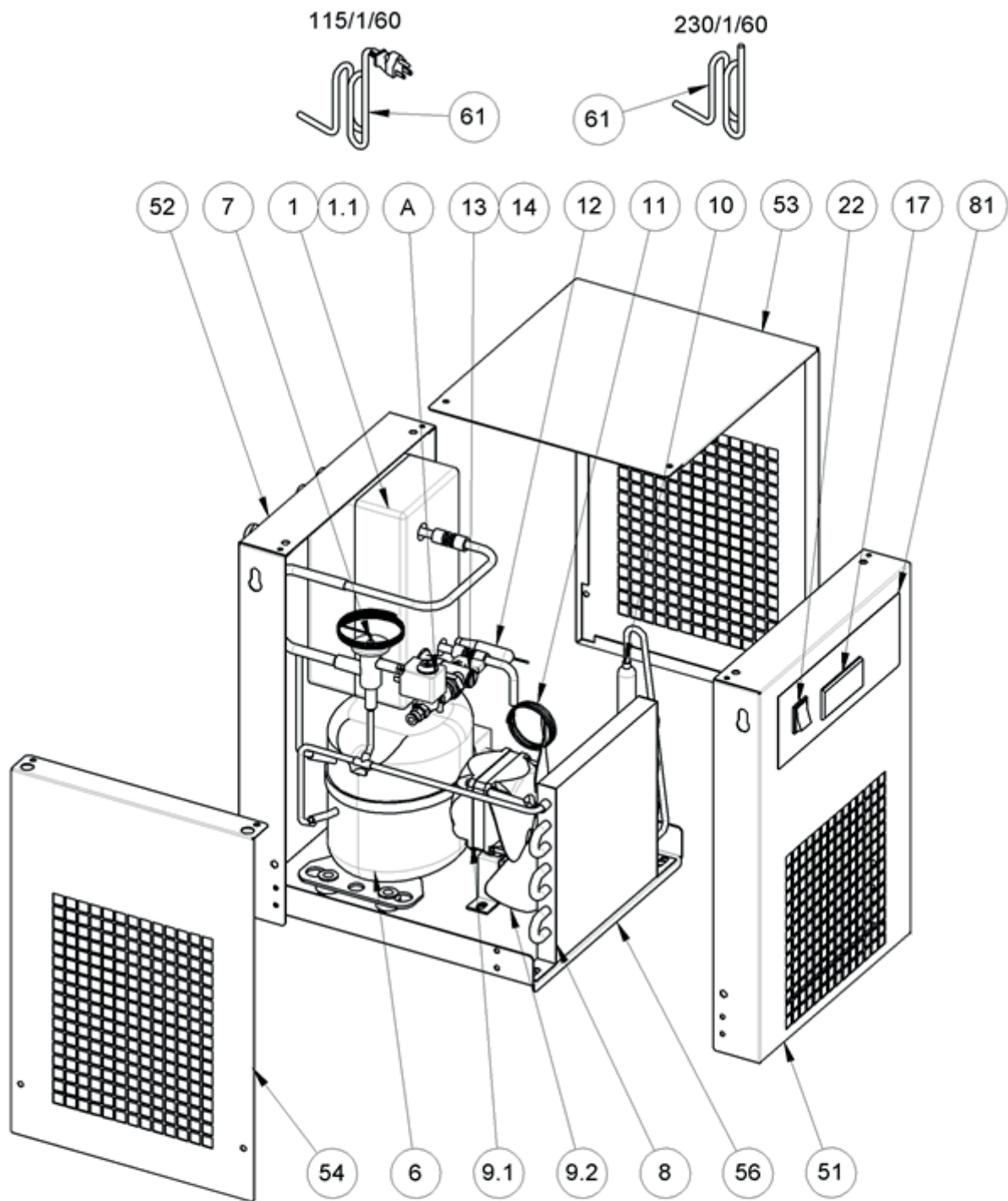

Pos. A standard

Pos. A optional

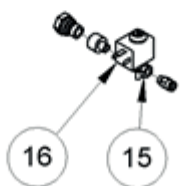

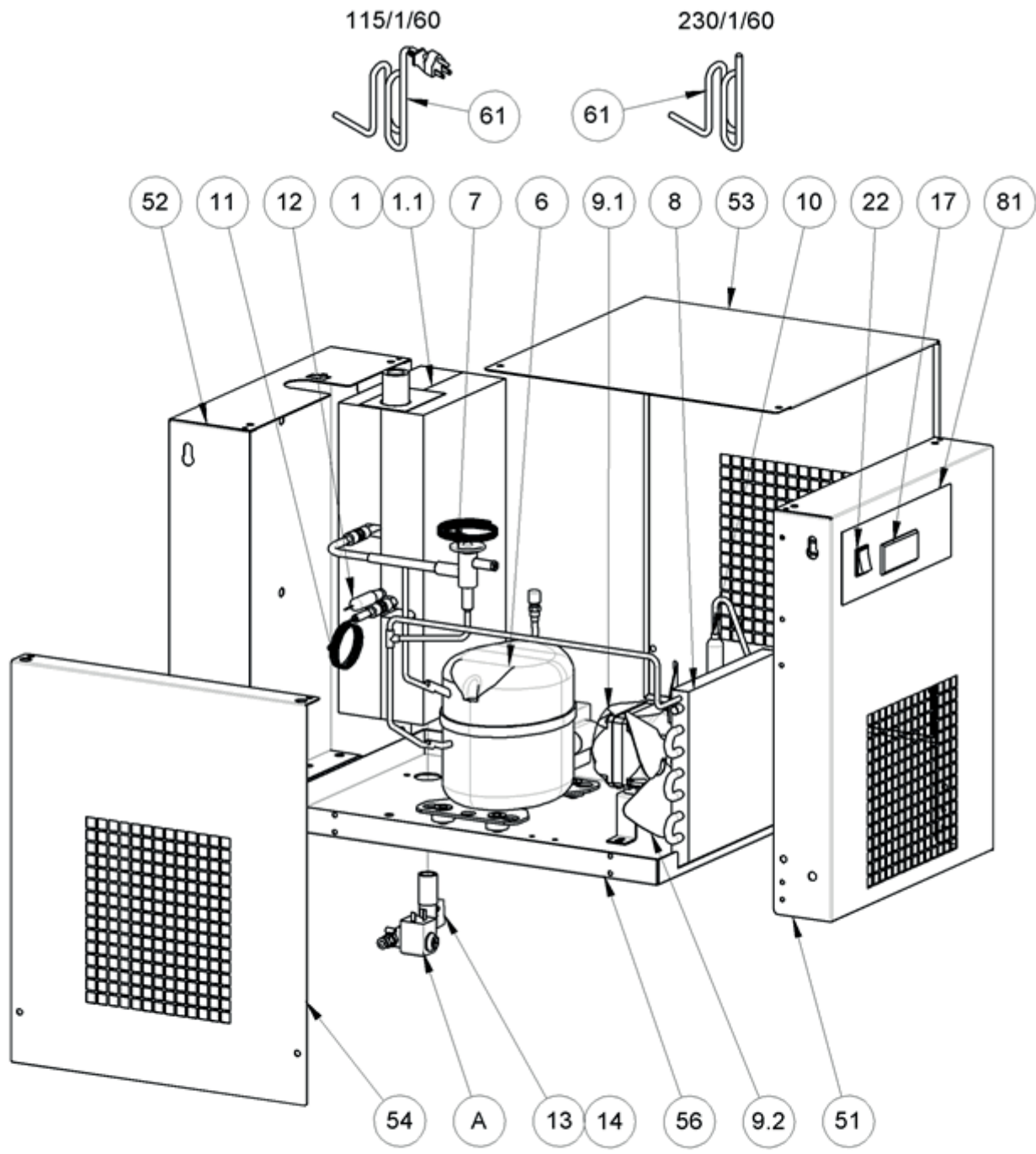

Pos. A standard

Pos. A optional

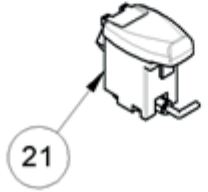
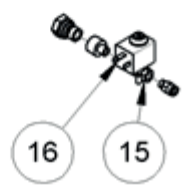

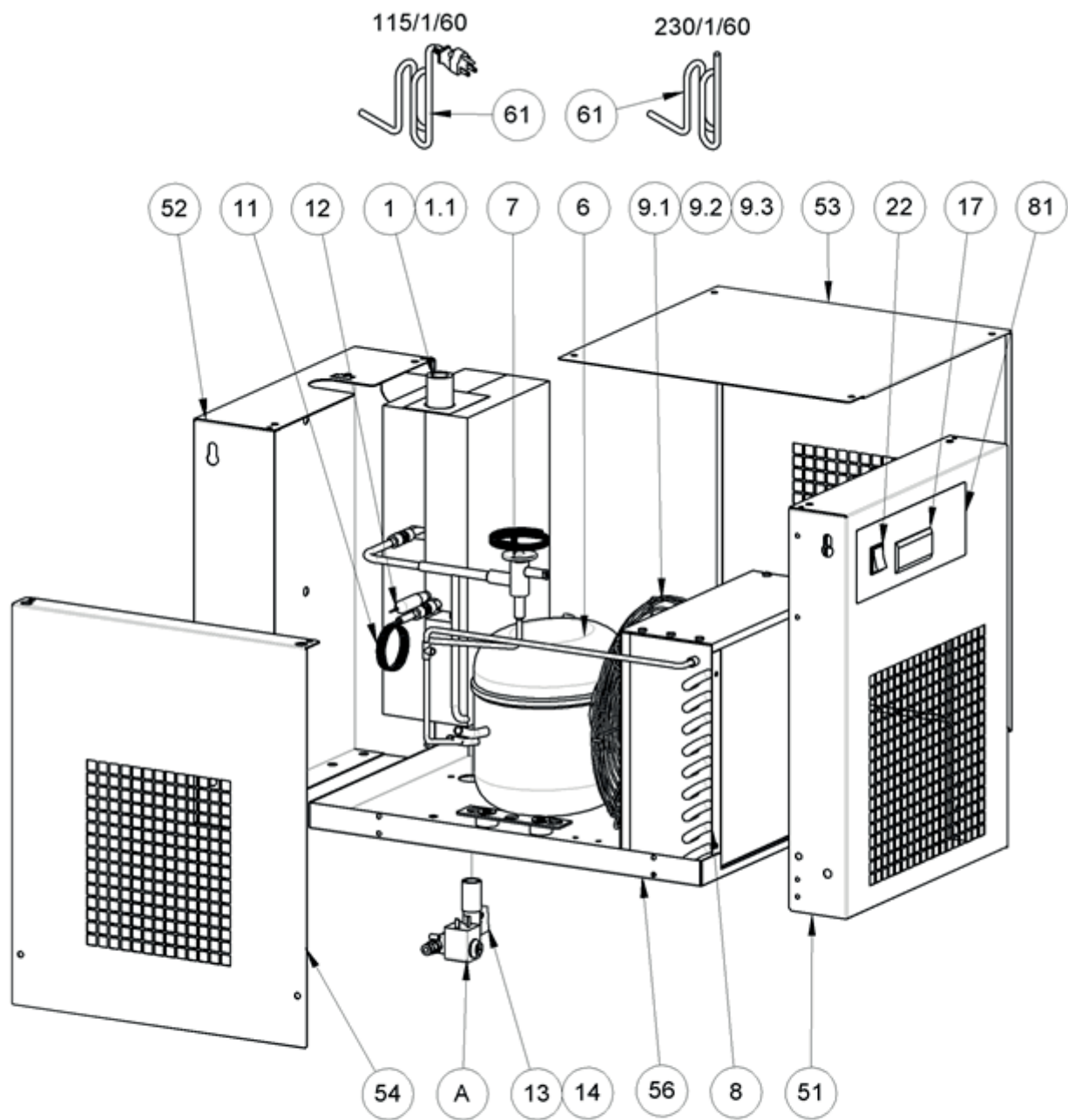

Pos. A standard

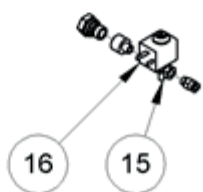

Pos. A option



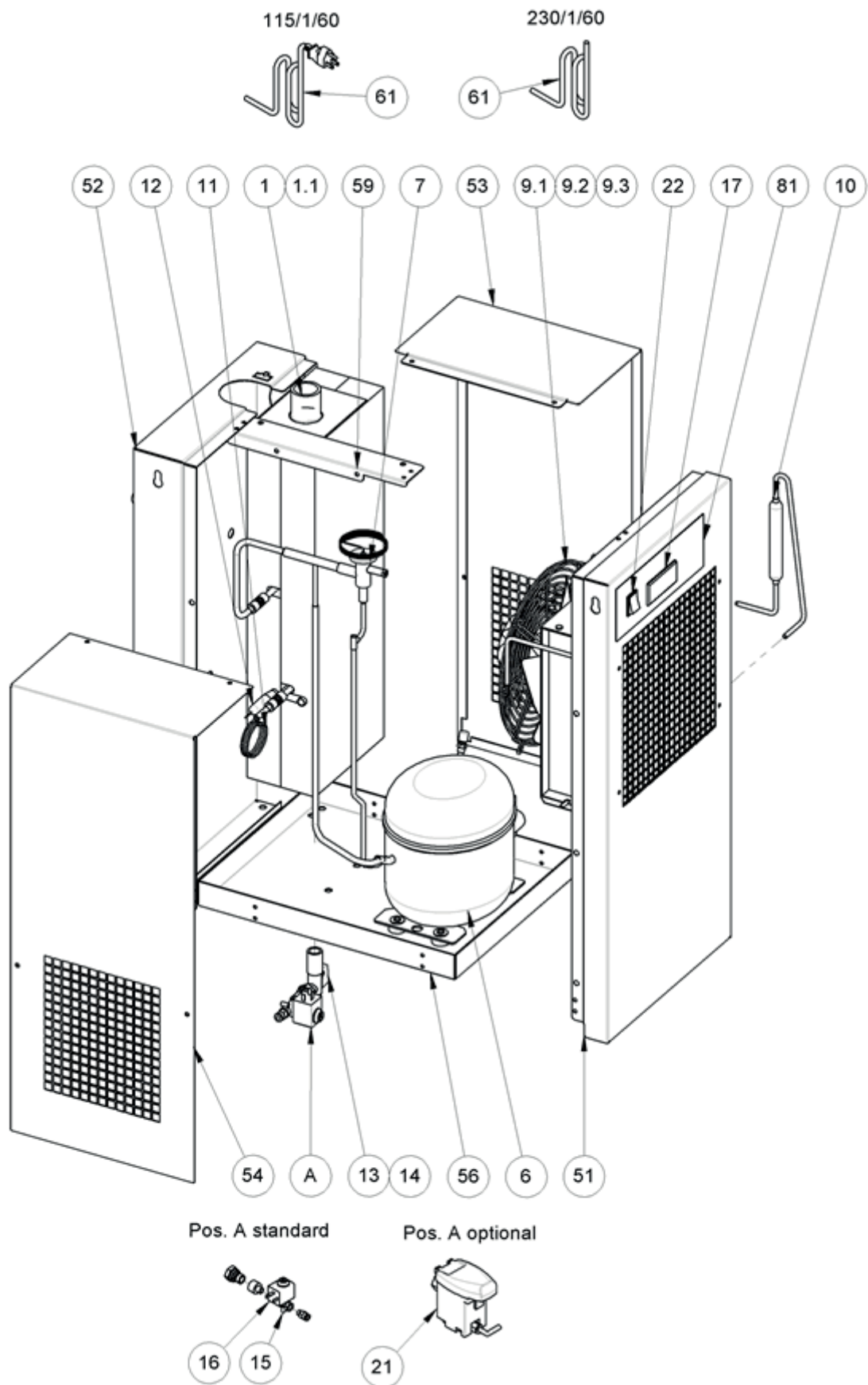

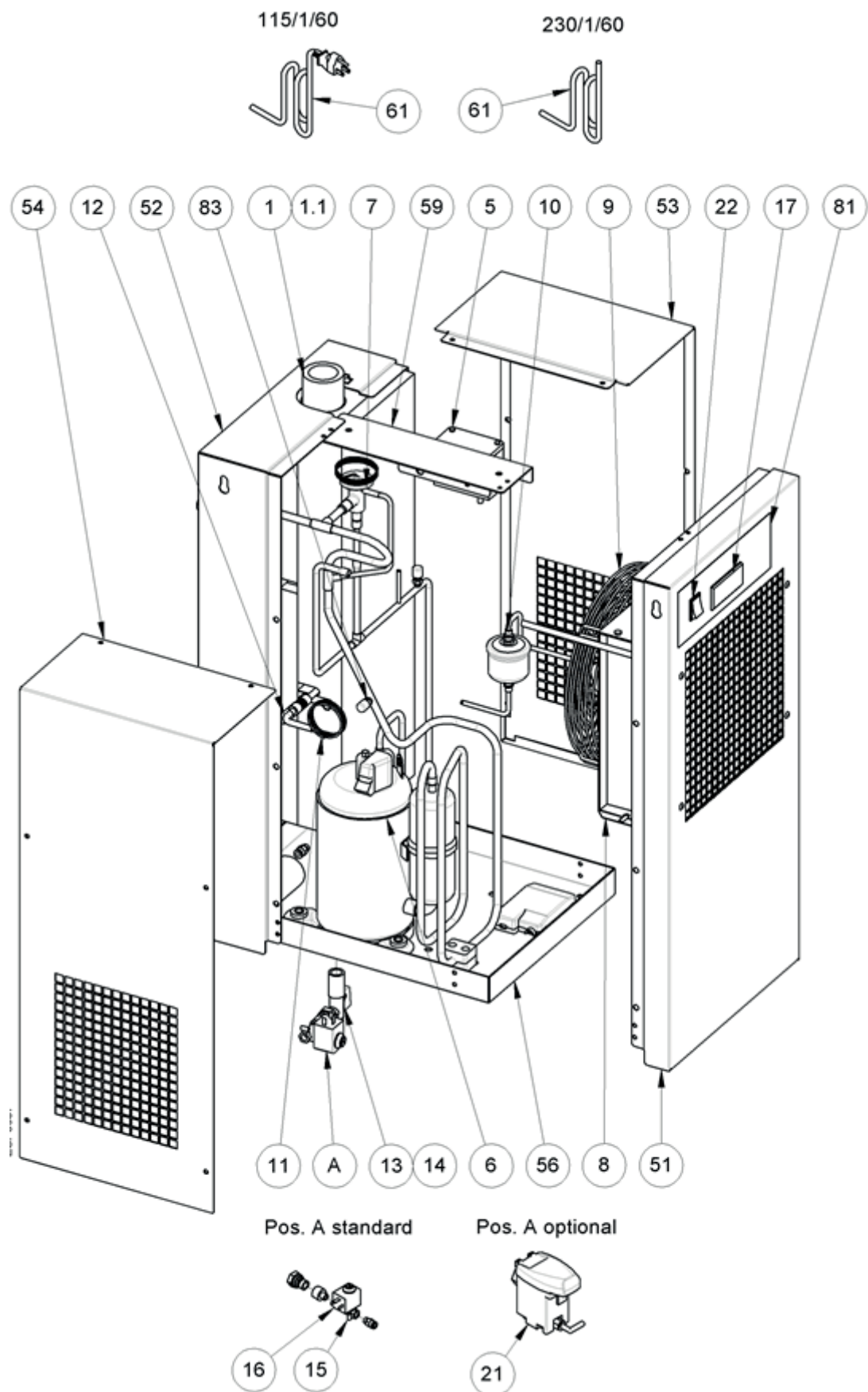

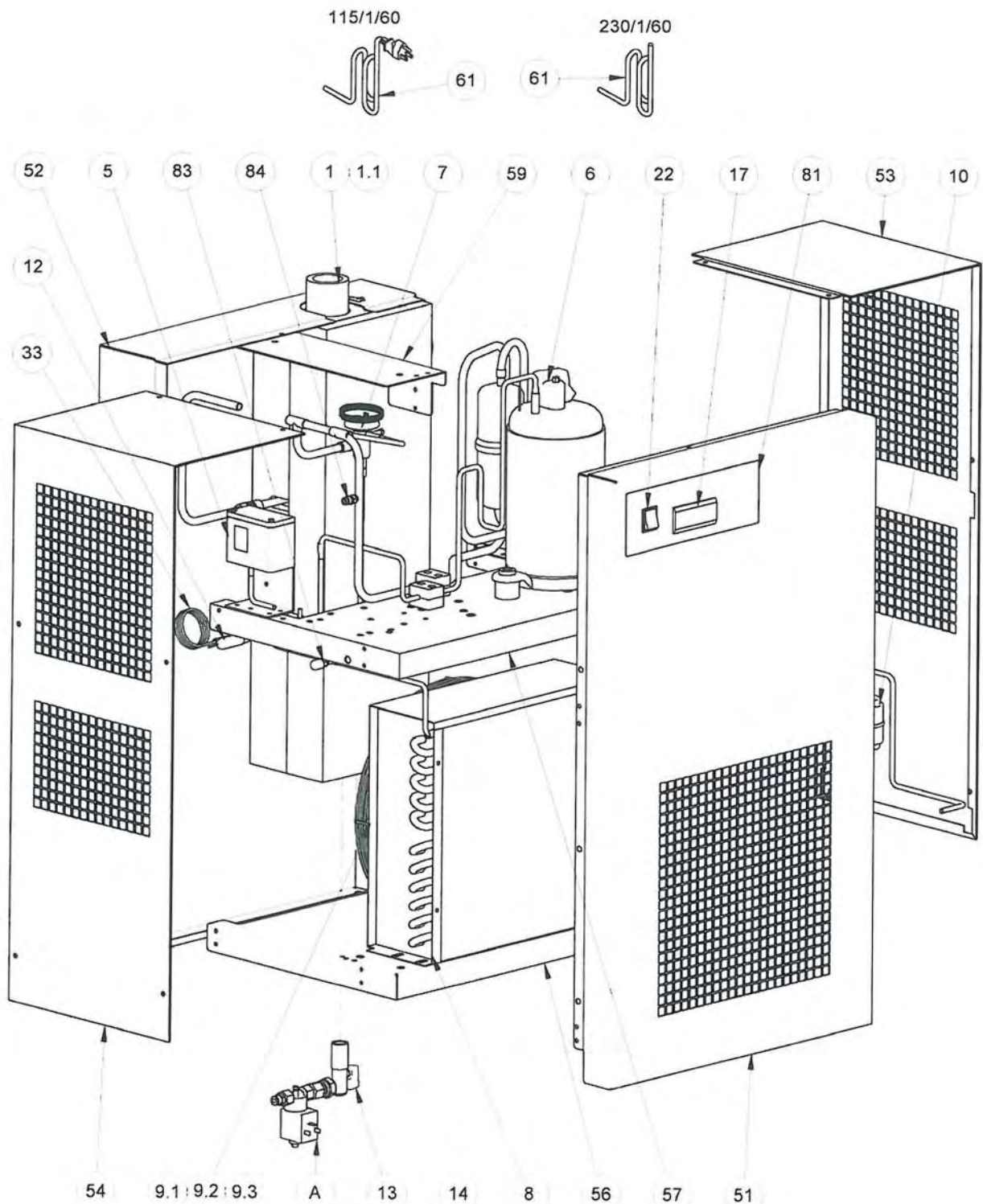

STANDARD

OPTIONAL

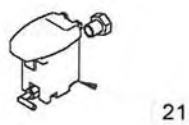
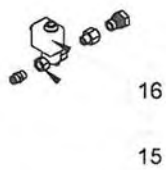

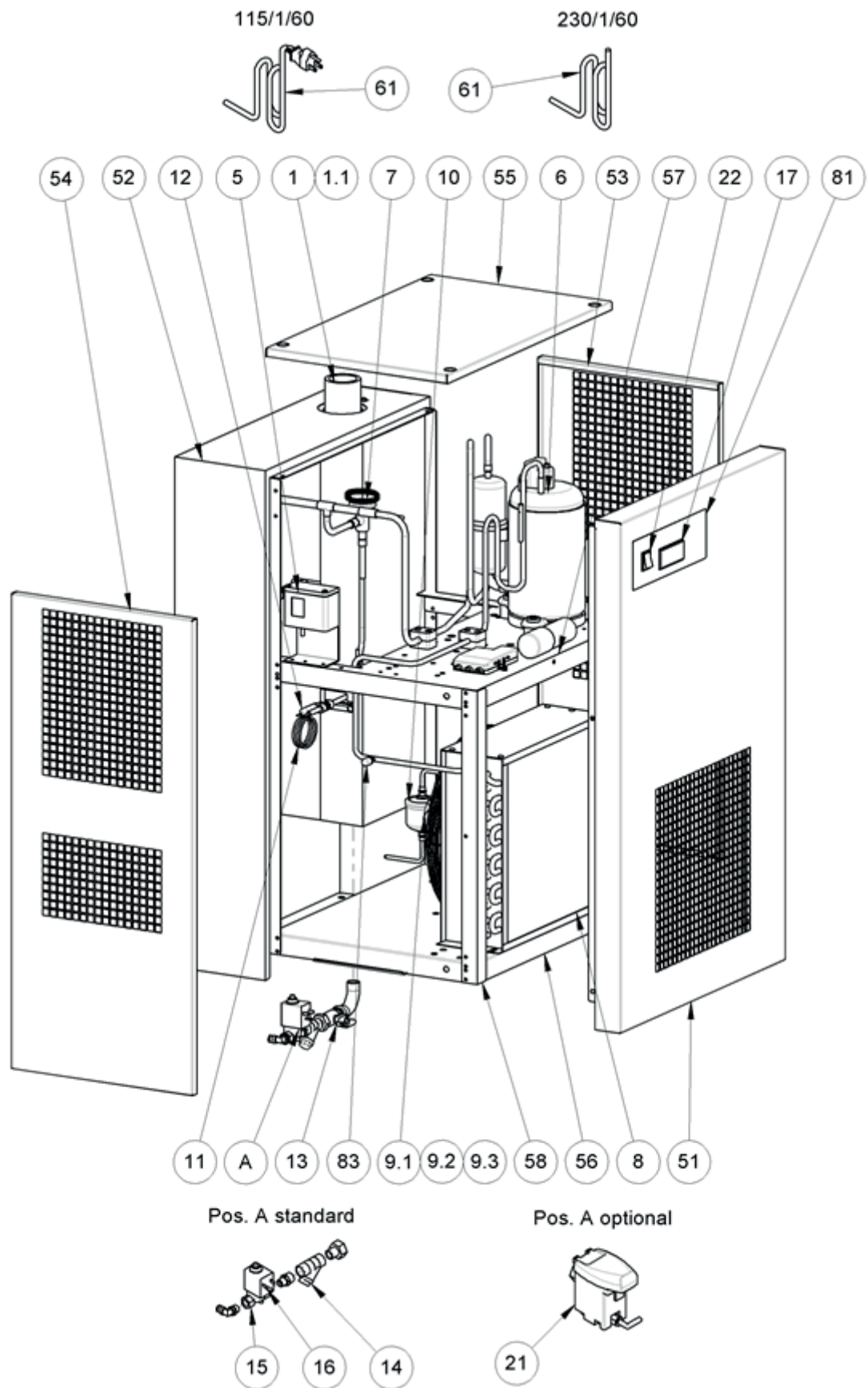

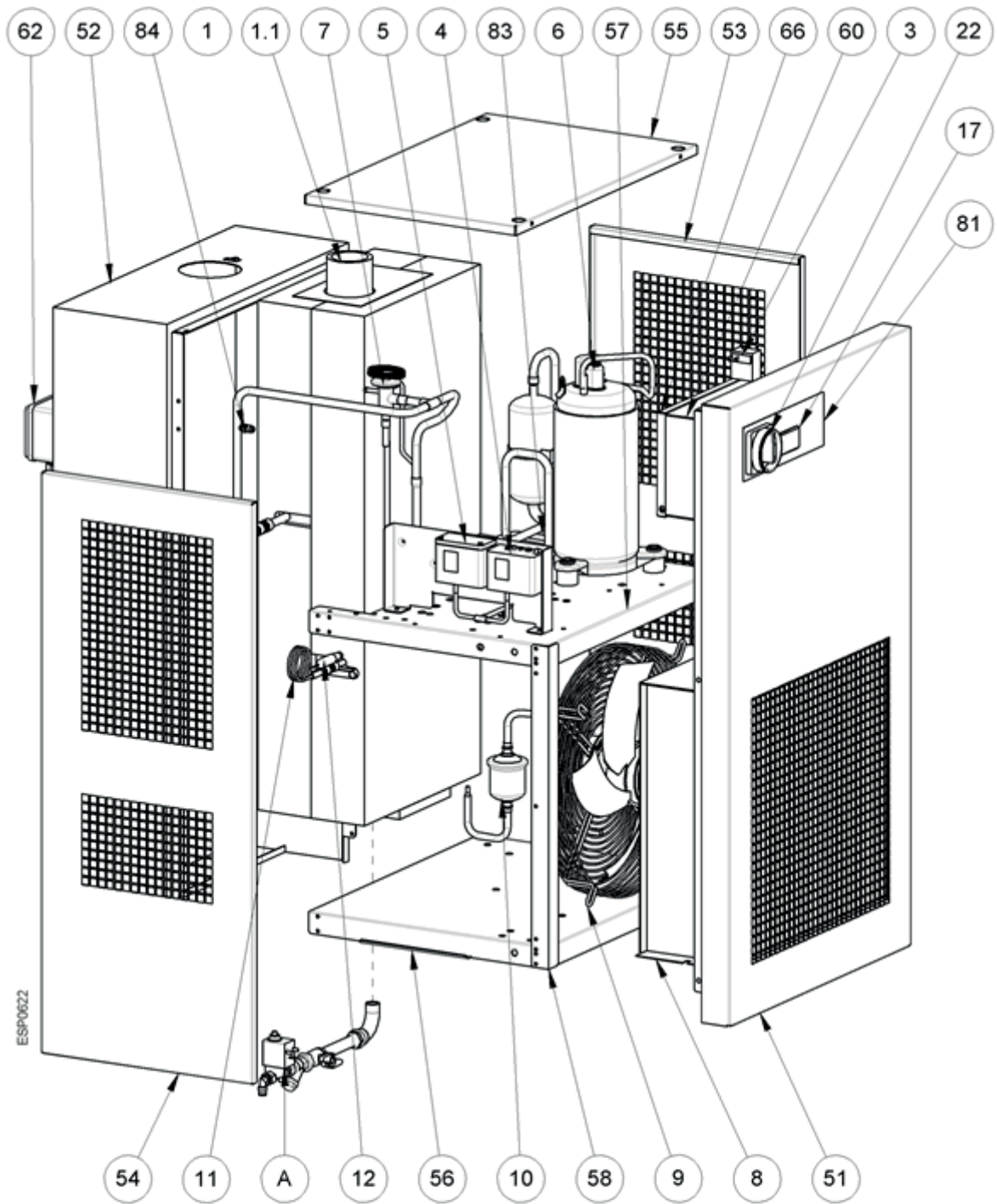

Pos. A standard

Pos. A optional

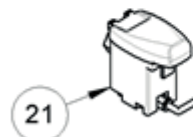
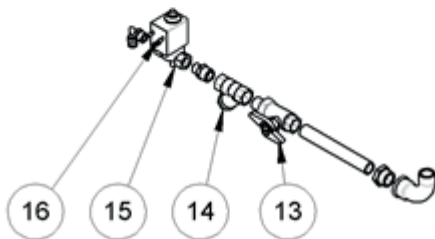

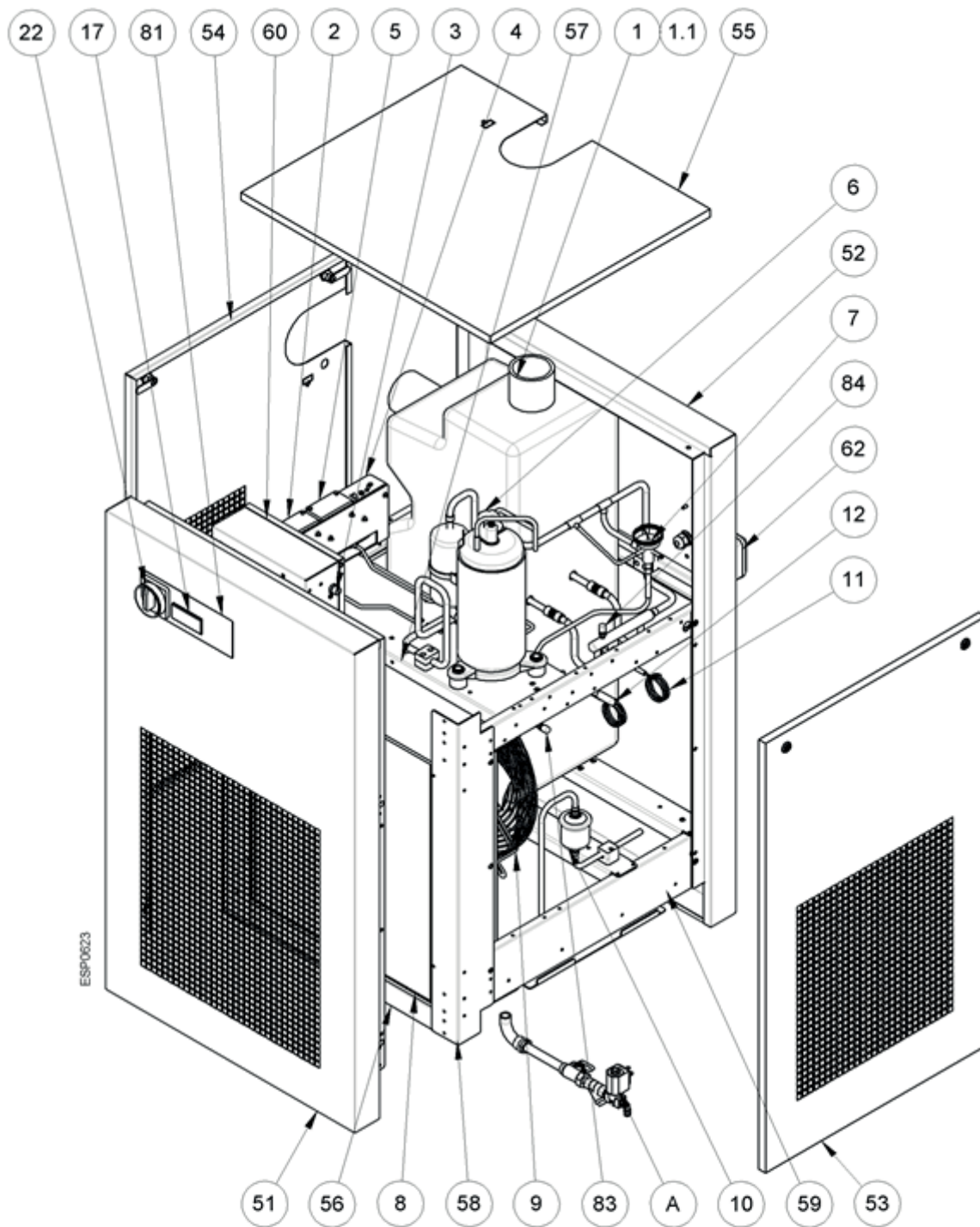

Pos. A standard

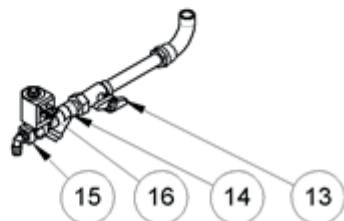

Pos. A optional

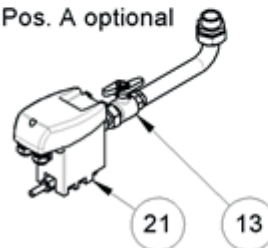

S E R V I Ç O S E
A T E N D I M E N T O
A O C L I E N T E

SAC

SCHULZ

ATENDIMENTO TÉCNICO BRASIL
0800 474141

de segunda a sexta-feira, das 8h às 18h

PEÇAS ORIGINAIS
Consulte a Rede de Assistência Técnica Autorizada

 **SCHULZ S.A.**
Rua Dona Francisca, 6901
Phone: 47 3451.6000
Fax: 47 3451.6060
89219-600 - Joinville - SC
schulz@schulz.com.br
www.schulz.com.br

SCHULZ

INFORMACIÓN TÉCNICA
TECHNICAL INFORMATION

export@schulz.com.br
+55 47 3451 6252

PIEZAS ORIGINALES
Consulte Distribuidor Autorizado

ORIGINAL
REPLACEMENT PARTS
Contact Authorized Distributor

 **SCHULZ OF AMERICA, INC.**
3420, Novis Pointe
Acworth, GA 30101
Phone # (770) 529.4731
Fax # (770) 529.4733
sales@schulzamerica.com
www.schulzamerica.com