



MSMH3030A

MODELS:
SMH3030

ITEM NUMBER: _____

SERIAL NUMBER: _____

Owner's Manual

Instructions for Assembly, Testing, Operation, Servicing, & Storage
Log Splitter: Outdoor hydraulic powered machine that splits wood logs.

⚠ WARNING

READ and UNDERSTAND this manual completely before using log splitter.

All operators of this equipment must read and completely understand all safety information, operating instructions, maintenance and storage instructions. Failure to properly operate and maintain the log splitter could result in serious injury to the operator and bystanders from moving parts that can crush or cut, flying objects, burns, fire or explosion, escaping high pressure hydraulic fluid, or carbon monoxide poisoning in particular, be aware of the following hazards.

Crush and Cut Hazards

Moving parts can crush and cut hands and fingers. Keep hands clear of ram, wedge, and logs, while splitting.

High Pressure Hydraulic Fluid Hazards

High fluid pressures and temperatures are developed in hydraulic log splitters. Hydraulic fluid escaping through even a pin-size hole opening can puncture skin and cause severe blood poisoning. Inspect hydraulic system regularly for possible leaks. Never check for leaks with your hand while the system is pressurized. Seek medical attention immediately if injured by escaping fluid.

Fire Hazards

- Keep a fire extinguisher rated "ABC" nearby. Keep it properly charged and be familiar with its use.

STOP!

READ YOUR SKID STEER MANUAL TO DETERMINE HOW TO HOOK UP TO SKID STEER

INSPECT COMPONENTS. Closely inspect upon receipt to make sure no components are missing or damaged. See "Assembly" section for instructions on whom to contact to report missing or damaged parts.

HYDRAULICS: There are many variations of auxiliary hydraulic connections on skid steers. Read your skid steer manual or check with your local dealer to determine how to properly connect the log splitter to your skid steer's auxiliary hydraulics.

Any Questions, Comments, Problems or Parts Orders

Call Iron & Oak Product Support 1-800-817-1005

Hazard Signal Word Definitions





	<p>This is the safety alert symbol. It is used to alert you to potential personal injury hazards. Obey all safety messages that follow this symbol to avoid possible injury or death.</p>
	<p>DANGER (red) indicates an imminently hazardous situation which, if not avoided, will result in death or serious injury.</p>
	<p>WARNING (orange) indicates a potentially hazardous situation which, if not avoided, could result in death or serious injury.</p>
	<p>CAUTION (yellow) indicates a potentially hazardous situation which, if not avoided, may result in minor or moderate injury.</p>
	<p>CAUTION (yellow) used without the safety alert symbol indicates a potentially hazardous situation which, if not avoided, may result in property damage.</p>

fig01453

Table of Contents

Hazard Signal Word Definitions	2
Table of Contents	3
About Your Log Splitter.....	4
Safety Label Locations	5
Machine Component Identification.....	7
Initial Set-up	8
Connecting to Skid Steer & Transporting to Job Site	9
Before Each Use – Work Site Selection and Set Up.....	13
Splitting Operation	15
Storage.....	18
Periodic Maintenance	19
Troubleshooting.....	20
Specifications	21
Parts Breakdown – Exploded View.....	22
Summary of Important Safety Information for Operation	24
Limited Warranty	28
Product Registration	28

About Your Log Splitter

Thank you for purchasing your Iron & Oak log splitter!

About Your Log Splitter:

This log splitter is a machine designed to split wood logs using a hydraulically powered moving ram and stationary wedge. The log splitter is connected to and powered by your skid steer's hydraulic system.

This log splitter is designed to split logs *lengthwise with the grain only*.

This log splitter model is capable of splitting logs up to 31" long and 24" in diameter.

Your splitter can be used in the horizontal splitting position only:

- When a splitter is set up to operate in the horizontal splitting position, the log splitter is positioned over the log and the ram moves horizontally pushing the log end into the wedge to split it.

The technical specifications for your log splitter are provided in the Specifications section of this manual.

WARNING

This log splitter uses a high-pressure hydraulic system to generate a very strong splitting force.

Read the manual completely before using the machine to understand how to safely operate and maintain it.

Follow all safety precautions presented throughout this manual. A summary of important safety information can be found at the end of this manual.

Contact Iron & Oak Product Support at 1-800-817-1005 for any questions about the appropriate use of this log splitter and/or optional accessories.

Warranty Registration:

Please fill in the warranty registration information in the back of this manual and have it on hand when you call in on a warranty claim or replacement parts.

Attention: All Rental Companies and Private Owners who loan this equipment to others!

All persons to whom you rent/loan the log splitter must have access to and read this manual. Keep this owner's manual with the splitter at all times and advise all persons who will operate the machine to read it. You must provide instruction on how to safely operate the splitter and remain available to answer any questions a renter/borrower might have.

Safety Label Locations

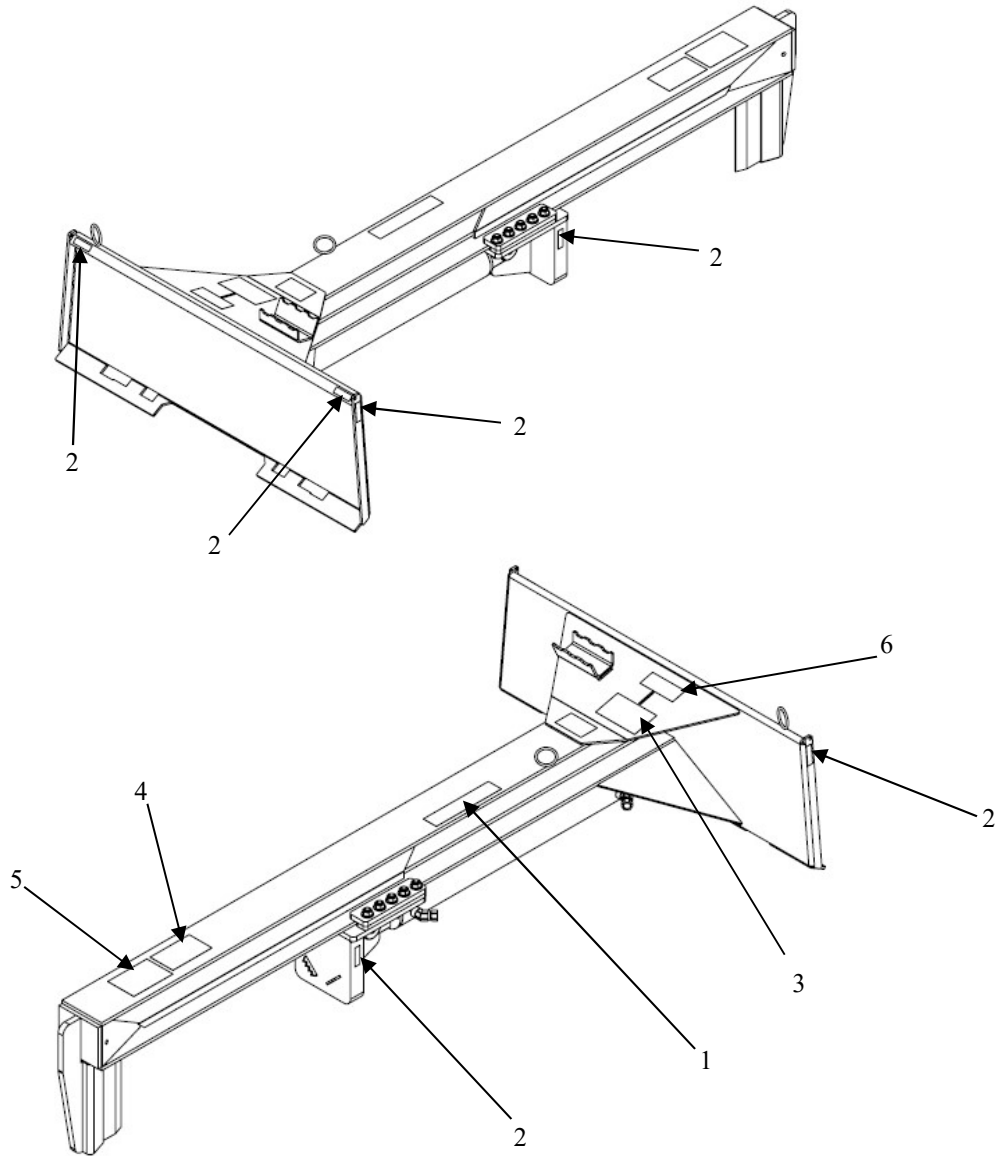

Reference #	Part Number	Description	Qty
1	800722	Decal, Connecting/Driving	1
2	787944	Decal, Pinch Point	6
3	800718	Decal, Operation Instructions	1
4	777888	Decal, Stuck Log	1
5	800721	Decal, Log Splitter Warning	1
6	777891	Decal, Escaping Fluid	1

Always make sure safety labels are in good condition. If a safety label is missing or not legible, order new labels or unsafe operation could result. Contact Iron & Oak Product Support at 1-800-817-1005.

Safety Label Locations

1

CONNECTING AND DRIVING INSTRUCTIONS	
<p>Connecting to Skid Steer:</p> <ul style="list-style-type: none"> • Attach log splitter to skid steer by following directions in skid steer operator's manual. • Connect the hose with the male end from the log splitter attachment to the skid steer's female auxiliary hydraulic port. • Connect the host with the female end from the log splitter attachment to the skid steer's male auxiliary hydraulic port. 	<p>Driving with Log Splitter Attached:</p> <ul style="list-style-type: none"> • Read skid steer manual for instructions on driving with log splitter attached. • Drive slowly and with extra caution, especially on rough or sloped terrain. • It is recommended that you display a "Slow moving vehicle" (SMV) emblem. SMV signs are generally available at farm equipment dealers. • Check local, state and federal vehicle requirements before driving on public roads.

PN 800722

2

⚠ WARNING	
	<p>PINCH POINT Keep hands clear during operation.</p> 

787944

3

OPERATING INSTRUCTIONS	
<p>GENERAL</p> <ul style="list-style-type: none"> • Only operate from the skid steer seat. • Never actuate controls until the helper is 20ft away from log splitter, including any helpers assisting to load logs. • Wear eye protection, hearing protection, snug fitting gloves, and safety shoes or heavy boots. No loose or dangling apparel. <p>SETTING UP</p> <ul style="list-style-type: none"> • Operate log splitter on dry, level ground. • Start engine. 	<p>SPLITTING LOG</p> <ul style="list-style-type: none"> • Position splitter over log, against wedge. • Move auxiliary control to extend ram and split log. • Release auxiliary control to stop ram. • Move auxiliary control to return ram.

PN 800718

4

⚠ WARNING	
<p>IF LOG BECOMES STUCK ON WEDGE</p>	
<p>A log can become stuck to the wedge if the wedge becomes embedded in the log and the log doesn't split and separate. This can happen if the log is too stringy or tough to split completely. If this happens NEVER attempt to remove a stuck log by:</p> <ul style="list-style-type: none"> • Using the hydraulic force of the splitter • Modifying the splitter • Adding attachments to the splitter <p>Personal injury could result from log or metal pieces flying out at high speed toward the operator or bystanders, or the splitter could become damaged.</p> <p>ALWAYS remove the log MANUALLY using this procedure:</p> <ol style="list-style-type: none"> 1. Retract ram fully. 2. Turn engine OFF. 3. Remove stuck log from wedge manually with a pry bar or sledgehammer. <p>Important: Be extremely careful as log pieces may fly off as they separate from wedge. Wear safety goggles and make sure bystanders are clear.</p> <ol style="list-style-type: none"> 4. Do not attempt to resplit a stuck log once it has been removed from wedge. 	

5

⚠ WARNING	
	<p>Moving parts can crush and cut. Pieces can fly out while splitting. Follow safety rules for operating the log splitter or serious injury could result.</p> <ul style="list-style-type: none"> • READ the Owner's Manual completely before operating. • Only one person should operate the log splitter. If an assistant is helping to load logs, the operator should not actuate controls until the assistant is at least 20 ft away. • Stay in the Skid Steer Seat while actuating the controls. • Split wood in direction of the grain only. • Keep hands away from wedge, endplate/ram, and partly split logs. • Never leave log splitter unattended during operation. • Stay off slopes and slippery surfaces. <p>See additional safety rules in the Owner's Manual.</p>

PN 800721

6

⚠ WARNING	
	<p>ESCAPING HIGH PRESSURE HYDRAULIC FLUID HAZARD</p> <p>High fluid pressures and temperatures are developed in the hydraulic system. Hydraulic fluid escaping through even a pin-size hole opening can puncture skin and cause blood poisoning.</p> <ul style="list-style-type: none"> • Inspect hydraulic system regularly for leaks • Never check for leaks with your hand while system is pressurized. • Seek medical attention immediately if injured by escaping fluid.

Machine Component Identification

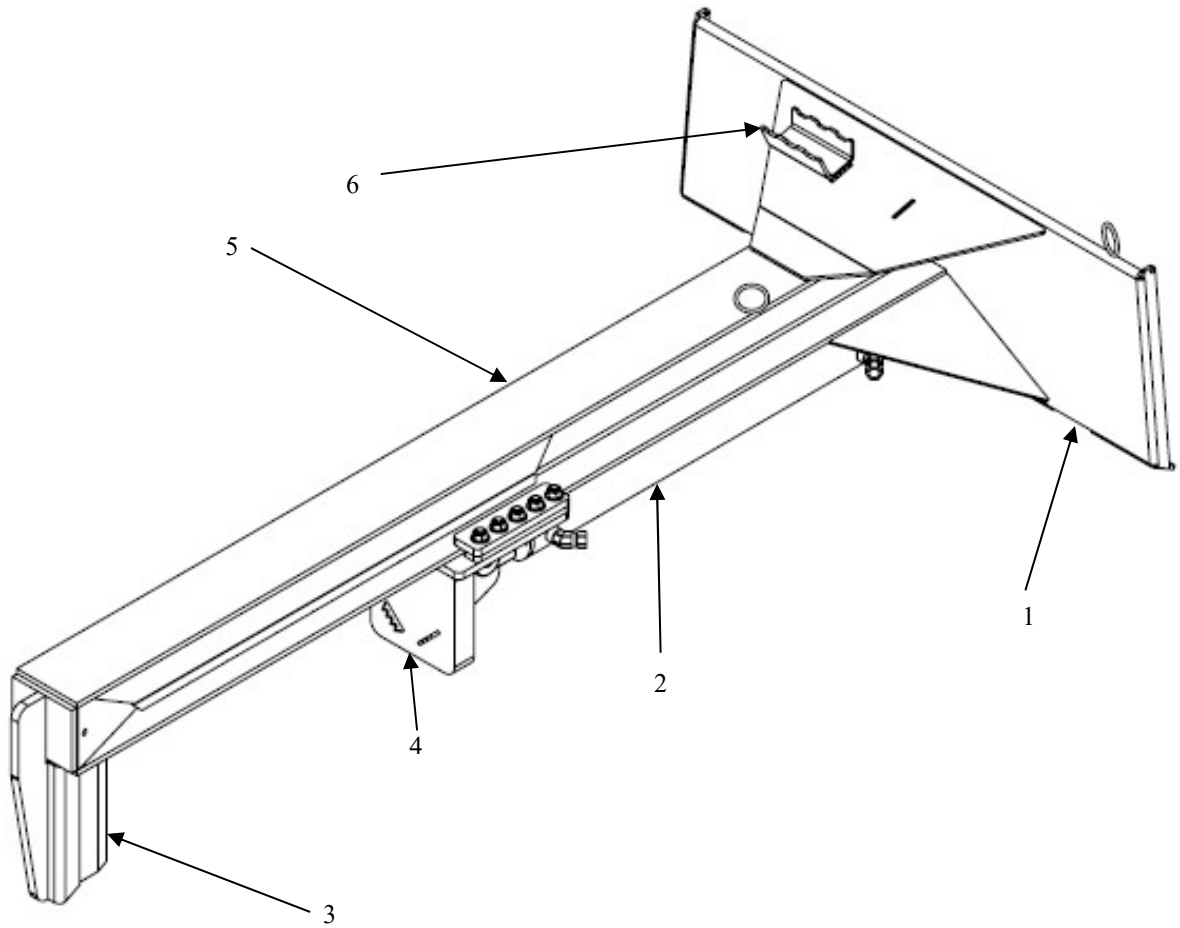

Ref	Description
1	Mount Plate
2	Cylinder
3	Wedge
4	Ram
5	Beam
6	Step

Initial Set-up

IMPORTANT!

Carefully read and follow all instruction for initial assembly and set-up of this log splitter. Failure to properly assemble and set up this equipment could result in serious injury to the user or bystanders, or cause equipment damage.

1. Inspect log splitter components

Closely inspect all log splitter components.

(See Machine Components section of this manual for diagram of components.)

- If you have missing or damaged components, please contact Product Support at 1-800-817-1005.

2. Lubricate beam

Apply grease to beam. This will help prevent wear between the ram and beam.

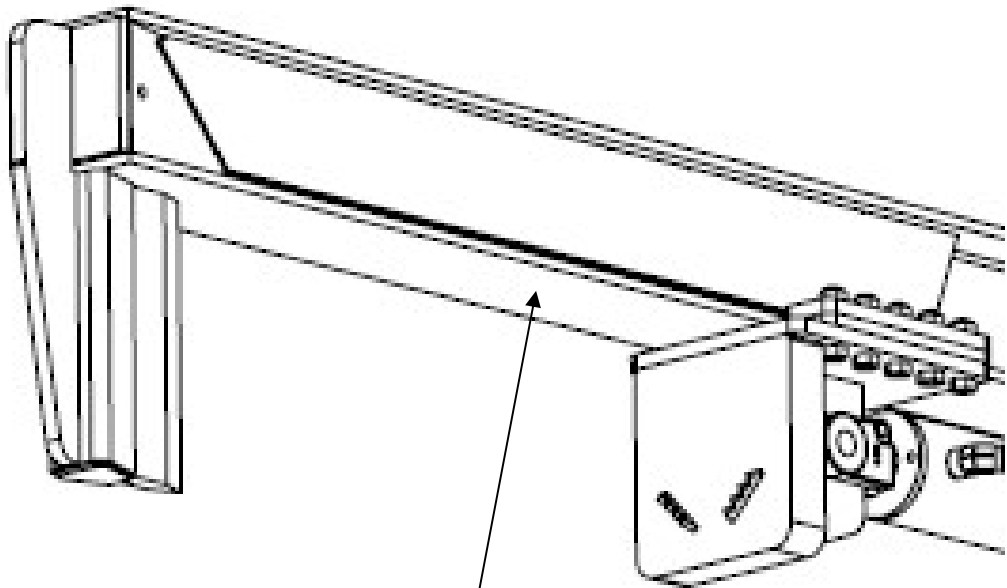

Apply grease to beam

Connecting to Skid Steer & Transporting to Job Site

WARNING

The log splitter must be correctly mounted and then attached to the skid steer hydraulic system for safe operation.

Follow the instructions below for safety mounting and connecting the log splitter. Also refer to the skid steer operator's manual for proper mounting and connecting directions.

1. Read instructions

Review your skid steer manual or check with your dealer for instructions and safety information about how to properly connect the log splitter to your skid steer's hydraulics.

Since there are many variations of hydraulic connections on skid steers, ensuring a correct hook-up to your skid steer is your responsibility.

2. Attach to Skid Steer quick attach plate

Attach log splitter to skid steer's universal quick attach plate.

Refer to skid steer operator's manual regarding proper attachment method for your skid steer.

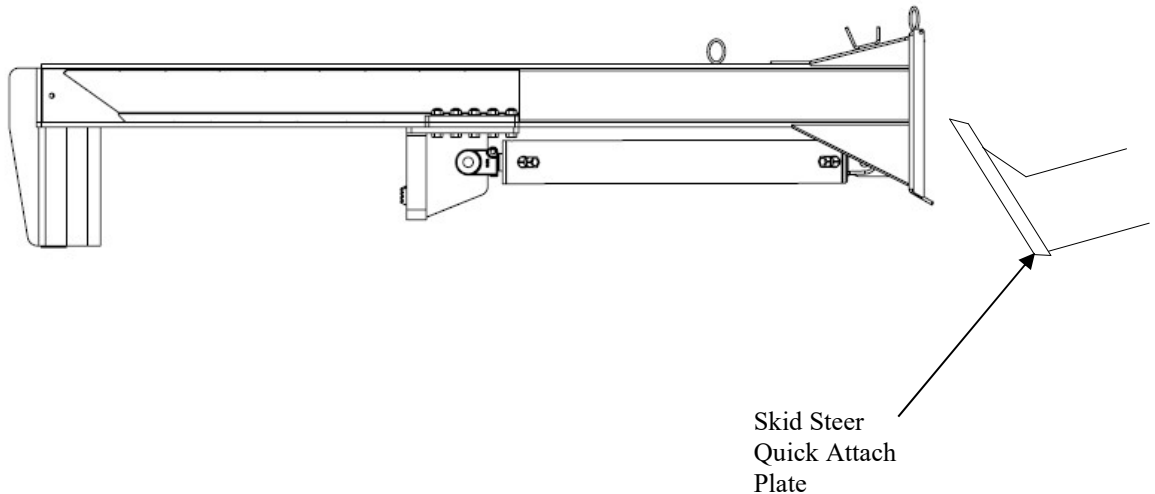

 WARNING: An improperly attached log splitter could become dislodged during transportation or operation, which could result in serious injury to the operator or bystanders. Do not drive the skid steer or operate the log splitter until you are sure the log splitter is properly attached.

Connecting to Skid Steer & Transporting to Job Site

3. Connect hydraulic hoses

Connect the hydraulic hoses:

- Connect the hose with the male end from the log splitter attachment to the skid steer's female auxiliary hydraulic port.
- Connect the hose with the female end from the log splitter attachment to the skid steer's male auxiliary hydraulic port.
- Check to be sure that all fittings are tight.

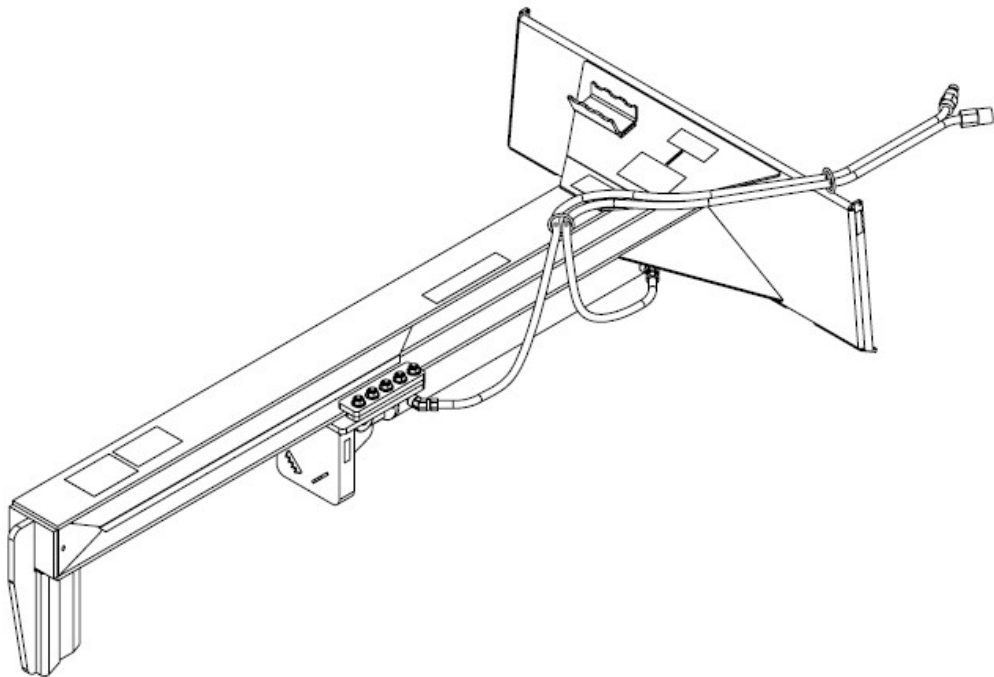

⚠ WARNING: Make sure all fittings are tight before applying pressure. High fluid pressures and temperatures are developed in the hydraulic system. Hydraulic fluid escaping through even a tiny opening can burn or puncture skin, resulting in wounds that could cause blood poisoning, infections, disability, gangrene, amputation, or death. If injured by escaping fluid, no matter how small the wound is, see a doctor at once.

4. Add hydraulic oil to reservoir

- Use skid steer auxiliary controls to extend and retract ram five (5) times to remove air from the high pressure lines.
- With ram retracted, check oil level again. Fill if necessary. Please refer to skid steer specifications for appropriate oil type.

Connecting to Skid Steer & Transporting to Job Site

5. Hydraulic components

Check the hydraulic components carefully:

1. Visually inspect all hoses and clamps/fittings for cracks, fraying, kinks, or other damage.
2. Check all components for oily residue, which may indicate a leak.

Do NOT operate the log splitter if there is any indication of damage or oily residue. Small leaks in hydraulic lines can cause severe injuries and can also be an indication of catastrophic failure in the near future. The life of hydraulic hoses may be from a few months to a few years, depending on use and storage patterns.

⚠️ WARNING: High fluid pressures and temperatures are developed in hydraulic log splitters. Hydraulic fluid escaping through a pin hole sized opening can burn or puncture skin, resulting in wounds that could cause blood poisoning, infection, disability, gangrene, amputation, or death. Therefore, the following instructions should be heeded at all times when inspecting or servicing the hydraulic components of the log splitter:

- Stop the skid steer and refer to the skid steer operator's manual on how to properly relieve pressure before changing or adjusting hydraulic system components such as hoses, tubing, fittings or other components.
- NEVER check for leaks with your hand. Leaks can be located by holding a piece of cardboard or wood (at least two feet long) with your hand at one end and passing the other end over the suspected area (wear eye protection). Look for discoloration of the cardboard or wood.
- NEVER adjust the relief pressure setting.
- If injured by escaping fluid, no matter how small the wound is, see a doctor at once. A typical injection injury may be a small puncture wound that does not look serious. However, severe infection or reaction can result if proper medical treatment is not administered immediately by a doctor who is familiar with injection injuries.

6. Lubricate beam

Apply grease to beam. This will help prevent wear between the ram and beam.

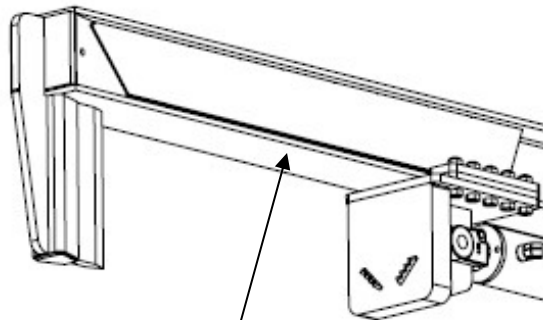

Apply Grease to Beam

Connecting to Skid Steer & Transporting to Job Site

Transporting:

1. Read instructions	Review safety instructions in your skid steer manual.
2. Drive to desired location	Drive skid steer and log splitter carefully to desired work site. (See instructions on pg.14 on selecting an appropriate work site) <u>Important safety instructions:</u> <ul style="list-style-type: none">• Read skid steer instructions. Review safety instructions in your skid steer manual with regard to driving with equipment attached.• Securely attached. Be sure splitter is securely attached before transporting.• Added length. Be aware of the added length of the splitter.• Reduced road stability. Be aware that heavy, mounted equipment can reduce road stability, regardless of the amount of rear-end counterweight added. Drivers should take extra caution when driving with the log splitter attached. Reduce your speed and take extra caution during turns or while driving on rough or sloped terrain.• No riding or cargo on splitter. Never ride or transport cargo on the log splitter.• On public roads. If transporting the log splitter on a public road, make sure to comply with all local, state, and federal requirements.• Unattended. Turn off the skid steer before leaving the splitter unattended.• Under the influence. Never transport or operate this splitter while under the influence of alcohol, drugs, or medication. <p>⚠ WARNING: Always engage the parking brake before leaving the skid steer while the splitter is attached.</p>

Before Each Use – Work Site Selection and Set Up

Step One: Inspect and maintain log splitter before each use

If the log splitter has been used previously, it must be inspected and maintained BEFORE EACH SUBSEQUENT USE.

WARNING

ALWAYS shut off the skid steer, disconnect hydraulic lines, and relieve system pressure before inspecting, cleaning, adjusting, or repairing the splitter. Refer to the skid steer operator's manual on how to properly relieve pressure.

IMPORTANT:

If a part needs replacement, only use parts that meet the manufacturer's specifications. Replacement parts that do not meet specifications may result in a safety hazard or poor operation of the log splitter.

1. Skid steer off / relieve hydraulic pressure	<p>Perform all inspections/repairs with the skid steer off and hydraulic pressure relieved.</p> <ol style="list-style-type: none"> 1. Turn off skid steer engine. 2. Refer to the skid steer operator's manual on how to properly relieve pressure. 3. Disconnect the hydraulic lines.
2. Remove debris	<p>Remove debris from moving parts</p> <p>Debris on moving parts can cause excess wear. Clear debris from the slide beam, wedge, and endplate.</p>
3. Lubricate beam	<p>Apply grease to beam. This will help prevent wear between the ram and beam.</p>
4. Mechanical parts	<p>Check to be sure that all nuts and bolts are tight to make sure the log splitter is in safe working condition.</p>
5. Hydraulic system	<p>Check the hydraulic system carefully:</p> <ol style="list-style-type: none"> 1. Visually inspect all hoses, tubing, clamps/fittings, and cylinder for cracks, fraying, kinks, or other damage. 2. Check all components for oily residue, which may indicate a leak. <p>Do NOT operate the log splitter if there is any indication of damage or oily residue. Small leaks in hydraulic lines can cause severe injuries and can also be an indication of catastrophic failure in the near future. The life of hydraulic hoses may be from a few months to a few years, depending on use and storage patterns.</p> <p> WARNING: High fluid pressures and temperatures are developed in hydraulic log splitters. Hydraulic fluid escaping through a pin hole sized opening can burn or puncture skin, resulting in wounds that could cause blood poisoning, infection, disability, gangrene, amputation, or death. Therefore, the following instructions should be heeded at all times when inspecting or servicing the hydraulic components of the log splitter:</p> <ul style="list-style-type: none"> • Refer to the skid steer operator's manual on how to properly relieve pressure before changing or adjusting hydraulic system components such as hoses, tubing, fittings or other components. • NEVER check for leaks with your hand. Leaks can be located by holding a piece of cardboard or wood (at least two feet long) with your hand at one end and passing the other end over the suspected area (wear eye protection). Look for discoloration of the cardboard or wood.

Before Each Use – Work Site Selection and Set Up

- NEVER adjust the relief pressure setting.
- If injured by escaping fluid, no matter how small the wound is, see a doctor at once. A typical injection injury may be a small puncture wound that does not look serious. However, severe infection or reaction can result if proper medical treatment is not administered immediately by a doctor who is familiar with injection injuries.

Step Two: Work site selection and log splitter set-up

 **WARNING**

It is important to select an appropriate work site and properly set up the log splitter in order to minimize the risk of slips and falls, equipment rolling or tipping over, carbon monoxide poisoning, and accidental fires.

1. Select location	<p>Select an appropriate location for operating the log splitter.</p> <p><u>Requirements:</u></p> <ol style="list-style-type: none"> 1. Dry-level surface with good footing. Stay clear of areas with mud, ice, tall grass, weeds, brush, or snow. 2. Outdoors and far away from windows, doors and air intakes. <p> WARNING: The running skid steer engine gives off carbon monoxide, a poisonous gas that can kill you. You CANNOT smell it, see it, or taste it.</p> <ul style="list-style-type: none"> • ONLY run log splitter <u>OUTDOORS</u> and away from air intakes. NEVER run log splitter inside homes, garages, sheds, or other buildings or semi-enclosed spaces. These spaces can trap poisonous gases, EVEN if you run a fan or open windows. • If you start to feel sick, dizzy or weak while using the log splitter, shut off the engine and get to fresh air RIGHT AWAY. See a doctor. You may have carbon monoxide poisoning.
2. Fire precautions	<p>Take the following precautions against fire:</p> <p>Keep a fire extinguisher available (classified for both ordinary combustibles & flammable liquids) as a precautionary measure when operating the log splitter in dry areas.</p>
3. Position skid steer 7' from any combustibles or flammable liquids	<p>Position skid steer exhaust and other hot elements of the skid steer engine at least 7 ft. from combustible objects during operation.</p> <p>Hot exhaust fumes from skid steer could cause fire. Also, hydraulic oil leaking or spraying on hot engine can ignite.</p>
5. Apply grease	<p>Apply grease to the beam.</p>

Splitting Operation

WARNING

Before starting this log splitter, review the following instructions and safety information for safe operation of the log splitter.

Failure to follow these rules may result in serious injury to the operator or bystanders from moving parts that crush, cut, or entangle from flying objects, burns, fire, falling or tripping, or from carbon monoxide poisoning.

General safety information:

- **Read manual.** Do not allow anyone to operate the log splitter who has not read the Owner's Manual or has not been instructed on the safe use of the splitter. The log splitter owner should instruct all operators in safe log splitter operation.
- **Age restrictions.** Never allow anyone under 16 years old to operate the log splitter. Anyone 16 years and older must be trained and supervised by a trained adult.
- **Intended use.** Log splitters should only be used for splitting wood logs, lengthwise with the grain. Do not use for other purposes as unforeseen hazards may result.
- **Modifications.** Never modify or alter the log splitter in any way. Modifications can create serious safety hazards and will void the warranty.
- **Attachments.** Never add attachments to the splitter, except for authorized accessories supplied by the manufacturer with instructions for safe installation and use.
- **Remote control.** NEVER attach a rope, cable, or other remote device to the splitting/skid steer controls.
- **Splitting wedge.** NEVER attempt to change the height or speed of the splitting ram.
- **Pressure setting.** NEVER increase the relief pressure setting.
- **Safety equipment / controls.** Always operate the log splitter with all safety equipment in place and in good working order, and all controls properly adjusted for safe operation.
- **Know how to stop.** Be thoroughly familiar with all controls and with the proper use of the equipment. Know how to stop the log splitter and relieve system pressures quickly if needed.
- **Daylight only.** Only use the log splitter in daylight so you can see what you are doing.
- **Smoking / sparks.** Never smoke while operating the log splitter, and never operate near sources of sparks or flames.
- **Under the influence.** Never operate, or let anyone else operate, the log splitter while under the influence of alcohol, drugs, or medication.
- **Unattended.** Never leave the machine unattended while the engine is running.
- **Adjusting / repairing.** Always make sure the engine is off before cleaning, repairing or adjusting the splitter, except as recommended by the manufacturer. In addition, refer to the skid steer operator's manual on how to properly relieve pressure *before changing or adjusting hydraulic system components* such as hoses, tubing, fittings or other components.
- **Replace labels.** Always make sure safety labels are in place and in good condition. If a safety label is missing or not legible, order new labels because unsafe operation can result. Call 1-800-817-1005 to order new safety labels.

Splitting Operation

1. Put on protective clothing / gear

Wear the following protective clothing and safety gear:

1. **Eye protection.** Always wear safety glasses or goggles when operating the machine. Pieces of log may fly out and serious eye injury can occur.
2. **Boots.** Falling logs can crush feet. Always wear safety shoes or heavy boots when operating or helping move logs.
3. **Gloves.** Wear snug fitting gloves without drawstrings or loose cuffs.
4. **Hearing protection.** The use of earplugs or other hearing protection device is recommended.
5. **No Loose / dangling.** Loose or dangling apparel can become entangled in moving parts. Never wear jewelry or loose-fitting clothing.

2. Position splitter

Use skid steer controls to place beam over log with a cut end against wedge – positioned for a lengthwise cut.

Notes:

- a) The log splitter is designed only for cutting lengthwise with the grain, NOT for cutting across the grain.
- b) This log splitter is designed for cutting logs only up to a maximum of 24" in diameter and 31" long. Larger diameter logs could get stuck on the wedge and longer logs will not fit between the wedge and the fully retracted ram.

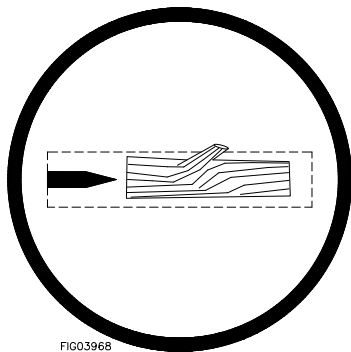

F1003966

Correct Log Orientation

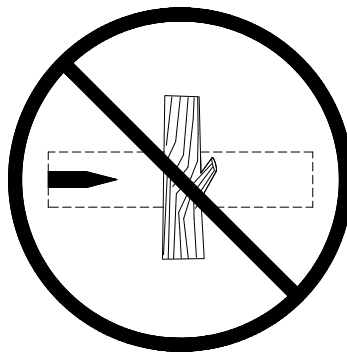

Incorrect Log Orientation

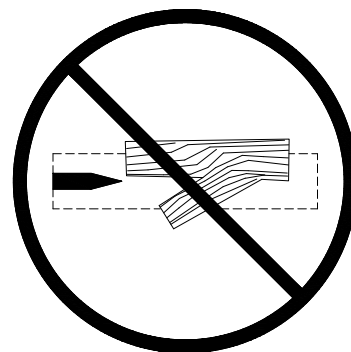

⚠ WARNING: ALWAYS keep hands and feet away from the ram, wedge, and partially split logs while operating the log splitter.

Important safety instructions:

- **Straddling/reaching across.** Never straddle, reach across, or step over the beam while the engine is running.
- **Square log ends.** Logs that are not cut square can slide out while splitting and become a safety hazard or cause excessive force to log splitter components. Use a chain saw to cut logs square on each end before attempting to split them.
- **Single log.** Never attempt to split more than one log at a time. Pieces of log can unexpectedly be thrown from the machine causing serious injury.
- **Split along grain.** Do not use the log splitter to split logs across the grain. Doing so will damage the log splitter and could also cause pieces of log to be thrown, injuring the operator or bystanders.

Splitting Operation

3. Extend ram	<p>Actuate skid steer auxiliary control as directed in skid steer operator’s manual to extend ram and split log.</p> <p><u>Important safety instructions:</u></p> <ul style="list-style-type: none"> • Operator position. ALWAYS operate the log splitter from seat of the skid steer. Other positions are unsafe because they can increase the risk of injury from crushing, cutting, or flying objects. • Cab control activation. NEVER attach a rope, cable, or other remote device to the splitting or skid steer controls to attempt to actuate remotely. • Second person. Many accidents occur when there is more than one person involved in operating the log splitter. Only one person should operate the controls. <i><u>If a second person is assisting in moving logs, the operator must NEVER actuate any splitting or skid steer controls until the assistant and all bystanders are at least 20 feet away. NEVER allow an assistant to hold the log in place while the operator actuates the splitting or skid steer controls.</u></i>
4. Stop wedge	<p>Release skid steer auxiliary control to stop wedge movement when log is split.</p> <p style="text-align: center;">⚠WARNING: Cracks in logs can close quickly and pinch fingers. Keep fingers away from any cracks that open in partially split logs.</p>
5. Important STUCK LOG procedure	<p>If a log does not split completely and becomes stuck on the wedge, follow the instructions below to remove the log.</p> <p>A log can become stuck to the wedge if the wedge becomes embedded in the log and the log doesn’t split and separate. This can happen if the log is too stringy or tough to split completely. If this happens, follow the directions below.</p> <p>⚠WARNING: NEVER attempt to remove a stuck log by:</p> <ul style="list-style-type: none"> • Using the hydraulic force of the splitter • Modifying the splitter • Adding attachments to the splitter • Personal injury could result from log or metal pieces flying out at high speed toward the operator or bystanders, or the splitter could become damaged. <ol style="list-style-type: none"> 1. Retract ram fully. 2. Turn engine OFF. 3. Remove stuck log from the wedge manually with a pry bar or a sledgehammer. <ul style="list-style-type: none"> <u>Important:</u> Be extremely careful as log pieces may fly off as they separate from the wedge. Make sure bystanders are clear and wear safety goggles. <p>Do not attempt to re-split a stuck log once it has been removed from the wedge. Manually split with an axe or cut with a chainsaw.</p>
6. Return ram	<p>Actuate skid steer auxiliary control as directed in skid steer operator’s manual to retract ram.</p> <p>⚠WARNING: Stay clear while the ram is returning. It is still powerful enough on the return stroke to cause serious injury.</p>
7. After use	<p>Turn off skid steer.</p>

Storage

Follow the instructions below for storing your log splitter between uses.

1. Retract ram	Retract the ram completely to keep the rod protected from corrosion.
2. Wipe with oily rag	Wipe the beam, wedge, and ram with an oily rag to prevent corrosion.
3. Splitter storage location	Store the log splitter in a location away from corrosive material. <u>NOTE:</u> Do not store the log splitter near fertilizer or any other corrosive material.

Periodic Maintenance

In addition to the maintenance performed with each use, periodic maintenance should also be performed according to the following schedule.

WARNING

ALWAYS shut off the engine and relieve system pressure before cleaning, adjusting, or repairing the splitter. Refer to the skid steer operator's manual on how to properly relieve pressure.

IMPORTANT:

If a part needs replacement only use parts that meet the manufacturer's specifications. Replacement parts that do not meet specifications may result in a safety hazard or poor operation of the log splitter.

Hydraulic Components

 **WARNING:** High fluid pressures and temperatures are developed in hydraulic log splitters. Hydraulic fluid escaping through a pin hole sized opening can burn or puncture skin, resulting in wounds that could cause blood poisoning, infection, disability, gangrene, amputation, or death. Therefore, the following instructions should be heeded at all times when inspecting or servicing the hydraulic components of the log splitter.

- NEVER check for leaks with your hand. Leaks can be located by holding a piece of cardboard or wood (at least two feet long) with your hand at one end and passing the other end over the suspected area (wear eye protection). Look for discoloration of the cardboard or wood.
- NEVER adjust the relief pressure setting.

If injured by escaping fluid, no matter how small the wound is, see a doctor at once. A typical injection injury may be a small wound that does not look serious. However, severe infection or reaction can result if proper medical treatment is not administered immediately by a doctor who is familiar with injection injuries.

1. **Refer to your skid steer's manual for proper hydraulic component maintenance.**
2. **Use only hydraulic oil approved by skid steer manufacturer.**
3. **After following your skid steer's manual for proper hydraulic component maintenance, check hydraulic oil reservoir level.**
4. **Start skid steer and use skid steer auxiliary controls to extend and retract ram five (5) times to remove air from the high pressure lines.**
5. **With ram retracted, check oil level again. If necessary, fill according to skid steer manufacturer's specifications.**

Troubleshooting

WARNING

Before troubleshooting or attempting to service, read the following safety instructions to avoid serious injury to the operator or bystanders from moving parts that can crush or cut, burns, fire or explosion, or escaping high pressure hydraulic fluid.

Important Safety Instructions:

1. **Skid Steer off.** Always make sure the skid steer engine is off before cleaning, repairing or adjusting the splitter, except as recommended by the manufacturer.
2. **Hydraulic safety.** High fluid pressures and temperatures are developed in hydraulic log splitters. Hydraulic fluid escaping through a pin hole sized opening can burn or puncture skin, resulting in wounds that could cause blood poisoning, infection, disability, gangrene, amputation, or death. Therefore, the following instructions should be heeded at all times when inspecting or servicing the hydraulic components of the log splitter:
 - Refer to the skid steer operator’s manual on how to properly relieve pressure before changing or adjusting hydraulic system components such as hoses, tubing, fittings or other components.
 - NEVER check for leaks with your hand. Leaks can be located by holding a piece of cardboard or wood (at least two feet long) with your hand at one end and passing the other end over the suspected area (wear eye protection). Look for discoloration of the cardboard or wood.
 - If injured by escaping fluid, no matter how small the wound is, see a doctor at once. A typical injection injury may be a small puncture wound that does not look serious. However, severe infection or reaction can result if proper medical treatment is not administered immediately by a doctor who is familiar with injection injuries.

Problem	
Ram will not move	Solution: A,D,E,H,J
Slow ram speed when extending or retracting	Solution: A,B,C,H,I,K
Wood will not split or splits extremely slow	Solution: A,B,C,F,I,K
Skid steer engine bogs down during splitting	Solution: G
Skid steer engine stalls under low load condition	Solution: D,E
Cause	Solution
A- Insufficient oil to pump	Check oil level in reservoir
B- Air in oil	Check oil level in reservoir, check for leaks in the suction line
C- Excessive pump inlet vacuum	Check pump inlet hose for blockage or kinks
D- Blocked hydraulic lines	Flush and clean the splitter hydraulic system
E- Blocked control valve	Flush and clean the splitter hydraulic system
F- Low relief valve setting	Skid steer requires service from authorized dealer
G- High relief valve setting	Skid steer requires service from authorized dealer
H- Damaged auxiliary control	Skid steer requires service from authorized dealer
I- Internal leak	Skid steer requires service from authorized dealer
J- Damaged cylinder piston	Return cylinder for authorized repair
K- Internally damaged cylinder	Return cylinder for authorized repair

Any Questions, Comments, Problems or Parts Orders
Call Iron & Oak Product Support 1-800-817-1005

Specifications

Tonnage.....	30 TON
Max Pressure.....	3500 PSI
Hydraulic Cylinder Bore....	4.5”
Hydraulic Cylinder Stroke ..	30”
Maximum Log Diameter....	24”
Maximum Log Length	31”
Hydraulic Fluid Type.....	Depends on Skid Steer
Hydraulic Oil Capacity.....	Depends on Skid Steer
Overall Dimensions	93”L x 49”W x 24”H
Dry Weight.....	600 lbs

The manufacturer reserves the right to make improvements in design and/or changes in specifications at any time without incurring any obligation to install them on units previously sold.

Any Questions, Comments, Problems or Parts Orders
Call Iron & Oak Product Support 1-800-817-1005

Parts Breakdown – Exploded View

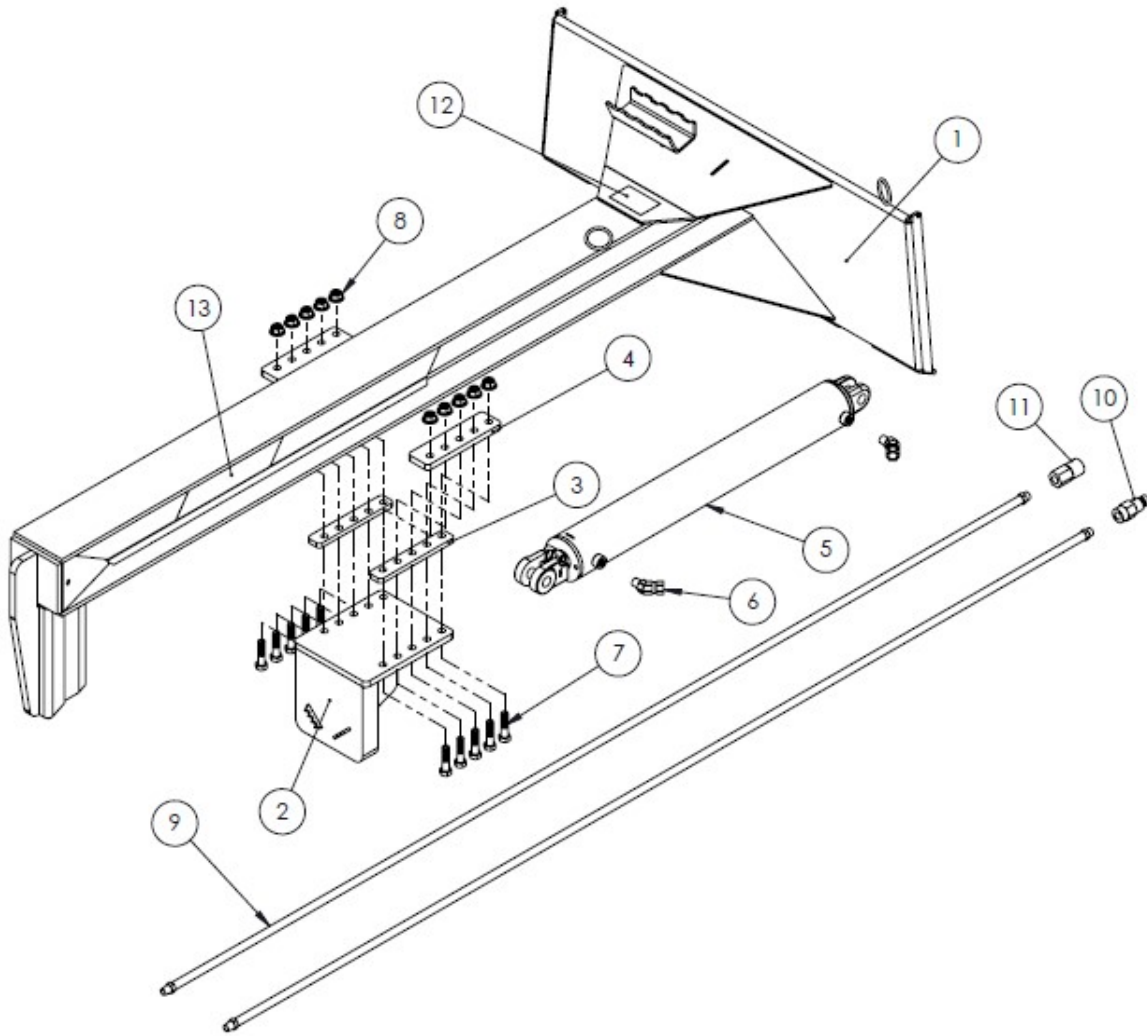

Parts Breakdown – Exploded View

ITEM NO.	PART NUMBER	DESCRIPTION	QTY.
1	12629	SSLS 30 In-Beam Weldment	1
2	12372	SSLS-Push Block Weldment	1
3	GNE-797804	KEEPER SPACER, ZINC	2
4	GNE-797805	KEEPER, ZINC	2
5	86849	Cylinder-4.5 x 30 Welded Clevis End	1
6	86836	1/2 NPT 45 Street Elbow	2
7	80090	BOLT, HHCS, 5/8-11 X 2.50, GR 8, Z	10
8	87468	NUT, TLFN, 5/8-11, GR F, Z	10
9	86784	Hydraulic Hose, 1/2", 9 Ft Long	2
10	85144	Hydraulic Coupler Male Flat Face	1
11	85145	Hydraulic Coupler Female Flat Face	1
12	86754	Decal - Made in USA	1
13	86862	Decal - I&O SMH3030	2

Summary of Important Safety Information for Operation

WARNING

Carefully read and make sure you understand the following safety information before using the log splitter. Improper use or maintenance of the log splitter can result in serious injury to the operator or bystanders from moving parts that can crush or cut, flying objects, burns, fire or explosion, escaping high pressure hydraulic fluid, or carbon monoxide poisoning.

Introduction

- **Read Manual.** Read this operator's manual and the skid steer operator's manual completely before attempting to use the log splitter. Serious injury or death can result if safety instructions are not followed.
- **Instruct operators.** The log splitter owner should instruct all operators in safe log splitter operation.
- **Intended use.** Log splitters should only be used for splitting wood logs, lengthwise with the grain. Do not use for other purposes, as unforeseen hazards may result.

Prohibition Against Modifications

Never modify or alter the log splitter in any way. Modifications can create serious safety hazards and will void the warranty.

- **Attachments.** Never add attachments to the splitter, except for authorized accessories supplied by the manufacturer with instructions for safe installation and use.
- **Remote Control.** NEVER attach a rope, cable, or other remote device to the skid steer controls.
- **Splitting Wedge.** NEVER attempt to change the height of the wedge or speed of the ram.
- **Pressure Setting.** NEVER increase the relief pressure setting.

Operator Restrictions

- **Untrained Operators.** Do not allow anyone to operate the log splitter who has not read the owner's manual or been instructed on the safe use of the splitter.
- **Minimum Operator Age.** Never allow anyone under age 16 to operate the log splitter. Anyone 16 years of age and older must be trained and supervised by a trained adult.

Safety in Connecting to Skid steer & Transporting

WARNING

The log splitter must be correctly mounted and then attached to the skid steer hydraulic system for safe operation. Follow the instructions below for safely moving and transporting the log splitter.

Safety in Connecting Log Splitter to Skid steer

- **Read skid steer instructions.** Review skid steer manual or get instructions from your skid steer dealer about how to properly connect the log splitter to your skid steer's auxiliary hydraulics.
- **Engage skid steer brake.** Make sure the skid steer's parking brake is engaged while you are attaching the log splitter.
- **Skid steer off.** The skid steer engine must be off while making connections to the skid steer's hydraulics.
- **Check mounting.** An improperly mounted log splitter could become dislodged during transportation or operation, which could result in serious injury to the operator or bystanders. Do not drive the skid steer or operate the log splitter until you are sure the log splitter is properly mounted.
- **Check hydraulic connections/fittings.** Make sure all hydraulic line fittings are tight before applying pressure. High fluid pressures and temperatures are developed in the hydraulic system. Hydraulic fluid escaping through even a tiny opening can burn or puncture skin, resulting in wounds that could cause blood poisoning, infection, amputation, or death. If injured by escaping hydraulic fluid, no matter how small the wound is, see a doctor at once.

Summary of Important Safety Information for Operation

Safety in Transporting to Job Site

- **Read skid steer instructions.** Review safety instructions in your skid steer manual with regard to driving with mounted equipment attached.
- **Securely attached.** Be sure the log splitter is securely attached before transporting.
- **Added length.** Be aware of the added length of the splitter.
- **Reduced road stability.** Be aware that heavy, skid steer mounted equipment can reduce road stability, regardless of the amount of rear-end counterweight added. Operators should take extra caution when driving with the log splitter attached. Reduce your speed and take extra caution during turns or while driving on rough or sloped terrain.
- **Rough terrain.** Be extra cautious and drive slowly when traveling over rough terrain.
- **No riding or cargo on splitter.** Never ride or transport cargo on the log splitter.
- **Under the influence.** Never transport or operate this splitter while under the influence of alcohol, drugs, or medication.
- **On public roads.** If transporting the log splitter on a public road, make sure to comply with all local, state, and federal towing requirements. It is the sole responsibility of the purchaser to obtain licensing, trailer lights, safety chains or signage, as needed to comply.
- **Unattended.** Turn off the skid steer and engage parking brake before leaving the splitter unattended.

Safety – Before Use

Read/instruct

- **Read manual.** Do not allow anyone to operate the log splitter who has not read the owner's manual or has not been instructed on the safe use of the splitter.
- **Review safety rules.** Before attaching log splitter to skid steer, review the "Rules for Safe operation." Failure to follow these rules may result in serious injury to the operator or bystanders.
- **Know how to stop.** Be thoroughly familiar with all controls and proper use of the equipment. Know how to stop the splitter and relieve system pressures quickly if needed.

Personal protective equipment

- **Eye protection.** Always wear safety glasses or goggles when operating the machine. Pieces of log may fly out and serious eye injury can occur.
- **Boots.** Falling logs can crush feet. Always wear safety shoes or heavy boots when operating or helping to load logs.
- **Loose/dangling.** Loose or dangling apparel can become entangled in moving parts. Never wear jewelry or loose-fitting clothing.
- **Gloves.** Wear snug fitting gloves without drawstrings or loose cuffs.
- **Hearing Protection.** The use of earplugs or other hearing protection device is recommended.

Safety During Inspection/Maintenance

Always inspect your log splitter before each use, and repair as needed, to keep it in safe working condition:

- **Engine off.** Always make sure the skid steer engine is off before cleaning, repairing or adjusting the splitter, except as recommended by the manufacturer.
- **Other debris.** Debris on moving parts can cause excess wear. With the skid steer engine off, clear debris from moving parts.
- **Mechanical parts.** Check to be sure that all nuts and bolts are tight to make sure the log splitter is in safe working condition.

Summary of Important Safety Information for Operation

- **Hydraulic system.** Check the hydraulic system (hoses, tubing, clamps/fittings, pump, and cylinder) carefully before each use. Do not operate the log splitter with frayed, kinked, cracked or damaged hydraulic hoses, fittings, or tubing, or if oily residue is observed on any of the components. High fluid pressures and temperatures are developed in the log splitter. Hydraulic fluid escaping through a pin hole sized opening can burn or puncture skin, resulting in wounds that could cause blood poisoning, infection, disability, gangrene, amputation, or death. Therefore, the following instructions should be heeded at all times when inspecting or servicing the hydraulic components of the log splitter:
 - Do not remove the hydraulic oil fill/vent cap when the engine is running. Hot oil can escape causing severe burns. Allow skid steer and splitter to cool completely before removing hydraulic oil fill/vent cap.
 - Do not adjust the relief pressure setting.
 - Do not check for leaks with your hand. Leaks can be located by holding a piece of cardboard or wood (at least two feet long) with your hand at one end and passing the other end over the suspected area (wear eye protection). Look for discoloration of the cardboard or wood.
 - Stop the skid steer engine and refer to the skid steer operator's manual on how to properly relieve pressure before changing or adjusting hydraulic system components such as hoses, tubing, fittings or other components.
 - If injured by escaping fluid, no matter how small the wound is, see a doctor at once. A typical injection injury may be a small puncture wound that does not look serious. However, severe infection or reaction can result if proper medical treatment is not administered immediately by a doctor who is familiar with injection injuries
- **Guards / shields.** Make sure all guards and shields are replaced after servicing the log splitter.
- **Replacement parts.** If a part needs replacement, only use parts that meet the manufacturer's specifications. Replacement parts that do not meet specifications may result in a safety hazard or poor operation of the log splitter.

Safety in Work Site Selection

- **Hot exhaust.** Hot exhaust fumes from the skid steer engine can cause fire. Position exhaust and other hot elements of engine at least 7' from combustible objects during operation.
- **Fire extinguisher.** Have a Class ABC fire extinguisher available as a precautionary measure when operating the log splitter in dry areas.
- **Level, dry surface.** To prevent accidental falls and equipment tip over, make sure the splitter and skid steer is situated on a dry, level surface with good footing. Stay clear of areas with mud, ice, tall grass, weeds, brush, or snow.
- **Carbon monoxide.** The running skid steer engine gives off carbon monoxide, a poisonous gas that can kill you. You CANNOT smell it, see it, or taste it. ONLY run log splitter OUTDOORS and away from air intakes. NEVER run log splitter inside homes, garages, sheds, or other semi-enclosed spaces. These spaces can trap poisonous gases, EVEN if you run a fan or open windows. If you start to feel sick, dizzy, or weak while using the log splitter, shut off the skid steer engine and get to fresh air RIGHT AWAY. See a doctor. You may have carbon monoxide poisoning.

Safety – During Use

 **WARNING:** Before attaching this log splitter, review the following rules for safe operation. Failure to follow these rules may result in serious injury to the operator or bystanders.

General Safety During Use

- **Safety equipment / controls.** Always operate the log splitter with all safety equipment in place and in good working order, and all controls properly adjusted for safe operation.

Summary of Important Safety Information for Operation

- **Know how to stop.** Be thoroughly familiar with all controls and with the proper use of the equipment. Know how to stop the log splitter and relieve system pressures quickly if needed.
- **Daylight only.** Only use the log splitter in daylight so you can see what you are doing.
- **Smoking / sparks.** Never smoke while operating the log splitter, and never operate near sources of sparks or flames.
- **Unattended.** Never leave the machine unattended while the skid steer engine is running.
- **Under the influence.** Never operate, or let anyone else operate, the log splitter while under the influence of alcohol, drugs, or medication.
- **Adjusting / repairing.** Always make sure the skid steer engine is off before cleaning, repairing or adjusting the splitter, except as recommended by the manufacturer. In addition, refer to the skid steer operator's manual on how to properly relieve pressure before changing or adjusting hydraulic system components such as hoses, tubing, fittings or other components.
- **Carbon monoxide.** The running skid steer engine gives off carbon monoxide, a poisonous gas that can kill you. You CANNOT smell it, see it, or taste it. If you start to feel sick, dizzy, or weak while using the log splitter, shut off the skid steer engine and get to fresh air RIGHT AWAY. See a doctor. You may have carbon monoxide poisoning.
- **Other exhaust dangers.** Engine exhaust, some of its constituents, and certain vehicle components contain or emit chemicals known to the State of California to cause cancer, birth defects, or other reproductive harm. Avoid inhalation of exhaust.

Safety in Loading, Operating, and Unloading

- **Square log ends.** Logs that are not cut square can slide out while splitting and become a safety hazard or cause excessive force to log splitter components. Use a chainsaw to cut logs square on each end before attempting to split them.
- **Single log.** Never attempt to split more than one log at a time. Pieces of log can unexpectedly be thrown from the machine causing serious injury.
- **Split along grain.** Do not use the log splitter to split logs across the grain. Doing so will damage the log splitter and could also cause pieces of log to be thrown, injuring the operator or bystanders.
- **Keep hands clear.** ALWAYS keep hands and feet away from the ram, wedge, and partially split logs while operating the log splitter.
- **Operator position.** ALWAYS operate the log splitter from the skid steer seat. Other positions are unsafe because they can increase the risk of injury from crushing, cutting, flying objects, or burns.
- **Straddling / reaching across.** Never straddle, reach across, or step over the beam while the engine is running.
- **Second person.** Many accidents occur when there is more than one person involved in operating the log splitter. Only one person should operate the controls. *If a second person is assisting in moving logs, the operator must NEVER actuate any splitting or skid steer controls until the assistant and all bystanders are at least 20 feet away. NEVER allow an assistant to hold the log in place while the operator actuates the splitting or skid steer controls.*
- **Cracks.** Cracks in logs can close quickly and pinch fingers. Keep fingers away from any cracks that open in partially split logs.
- **Cab control activation.** NEVER attach a rope, cable, or other remote device to the splitting or skid steer controls to attempt to actuate remotely.
- **Returning ram.** Stay clear while the ram is returning. It is still powerful enough on the return stroke to cause serious injury.
- **Log stuck on wedge.** NEVER attempt to remove a stuck log by:
 - Modifying the splitter.
 - Adding attachments to the splitter.

Personal injury could result from log or metal pieces flying out at high speed toward the operator or bystanders, or the splitter could become damaged.

Safety – After use

- **Storage location.** Store the log splitter in a location away from corrosive material.
- **Periodic maintenance.** Perform periodic maintenance as directed in this manual to keep the log splitter in safe working condition.

Limited Warranty

Dear Valued Customer:

The Iron & Oak product you just purchased is built with the finest material and craftsmanship. Use this product properly and enjoy the benefits from its high performance. By purchasing an Iron & Oak product, you show a desire for quality and durability. Like all mechanical equipment this unit requires a due amount of care. Treat this unit like the high-quality piece of machinery it is. Neglect and improper handling may impair its performance.

Thoroughly read the instructions and understand the operation before using your product. Always contact Iron & Oak Product Support at 1-800-817-1005 prior to having any service or warranty work performed, as some services performed by parties other than Iron & Oak approved service centers may void this warranty. This limited warranty is in lieu of any other warranty expressed or implied, written or oral and Iron & Oak assumes no other responsibility or liability outside that expressed within this limited warranty.

Limited Warranty for Log Splitter Models:

SMH3030

	Consumer Warranty Period	Commercial Warranty Period
Weldments		
	2 years from date of purchase by user	2 year from date of purchase by user
Cylinders, Valves, Pumps		
	2 years from date of purchase by user	1 year from date of purchase by user
Wear Parts	In addition to the normal warranty, Iron & Oak shall warrant some normal wear items from defects in material or workmanship for a period of 30 days from the date of purchase by user. Normal wear items covered under this warranty are limited to: pins, grease zerks, hoses, couplers, filters. Routine maintenance items such as lubricants, adjustments, tune ups are not covered under warranty.	

“**Consumer use**” means personal residential household use by a consumer. “**Commercial use**” means all other uses, including, but not limited to, use for commercial, income producing or rental purposes or when purchased by a business.

This limited warranty applies to the original purchaser of the equipment (verification of purchase, in the form of a receipt, is the responsibility of the buyer), is non-transferable, and covers parts and labor. Parts will be replaced or repaired at no charge, except when the equipment has failed due to lack of proper maintenance. If a part is no longer available, the part may be replaced with a similar part of equal function. Any misuse, abuse, alteration or improper installation or operations will void warranty. Determining whether a part is to be replaced or repaired is the sole decision of Iron & Oak. Iron & Oak will not provide for replacement of complete products due to defective parts. Any costs incurred due to replacement or repair of items outside of an Iron & Oak approved facility is the responsibility of the buyer and not covered under warranty. Transportation costs to and from service center and/or service calls are the responsibility of the customer.

This limited warranty specifically excludes the following: failure of parts due to damage caused by accident, fire, flood, windstorm, acts of God, applications not approved by Iron & Oak in writing, corrosion caused by chemicals, use of replacement parts which do not conform to manufacturer’s specifications, damage related to rodent and/or insect infestation and damage caused by vandalism. Additional exclusions: loss of running time, inconvenience, loss of income, or loss of use, including any implied warranty of merchantability of fitness for a specific use. Also, outdoor power equipment needs periodic parts and service to perform well, and this limited warranty does not cover instances when normal use has exhausted the life of a component or the engine.

This limited warranty does not cover any personal injury or damage to surrounding property caused by failure of any part, misuse or inability to use the product. Alteration of the product, including safety features, shall void this limited warranty.

Repair or replacement of parts does not extend the warranty period. This limited warranty gives you specific legal rights. You may also have other rights that vary by state.

Please have model number, item number and serial number on hand prior to making a warranty claim or inquiry.



Iron & Oak Product Registration Form

Your Information

Full Name:

Last

First

M.I.

Address:

Street Address

Apartment/Unit #

City

State

ZIP Code

Home Phone: _____

Alternate Phone: _____

Email Address: _____

Purchased From

Company: _____

Address:

Street Address

Apartment/Unit #

City

State

ZIP Code

Model Information

Purchase Date: _____

Application Type:

Homeowner

Commercial

Rental

Model (i.e. BHVH2418GX)

Serial # (i.e. BHVH2418GXA012345678)

Signature: _____

IMPORTANT WARRANTY INFORMATION

To activate your Iron & Oak log splitter warranty, please fill out the information in the form below and mail to:
Iron & Oak, 20195 S. Diamond Lake Rd., STE 100, Rogers, MN 55374 or go online to www.ironandoak.com and complete our online product registration form.



20195 S. Diamond Lake Rd, Ste 100
Rogers, MN 55374
1-800-350-8739