

READ AND SAVE THIS INSTRUCTION MANUAL



Air Cooler

Model SF-609



## Functions

1. Cooling, humidifying and air purifying
2. Adopted photo-catalysis technology, Anti-bacterial water tank and germ-free water curtain cycle system
3. Three fan air speeds with Sleep Mode function
4. Automatic swing
5. Timer from half an hour to Seven and a half hours
6. Castor wheels for portability
7. Remote control
8. Ionizer adopted

## Contents

- Parts Name
- Product Appearance
- Control Panel
- Important Safety Notes
- Operation
- Specifications
- Circuit Diagram
- Maintenance
- Trouble Shooting
- Your Guarantee

---

Please read the instruction carefully prior to use.

# Parts Name

## 1. Product Appearance

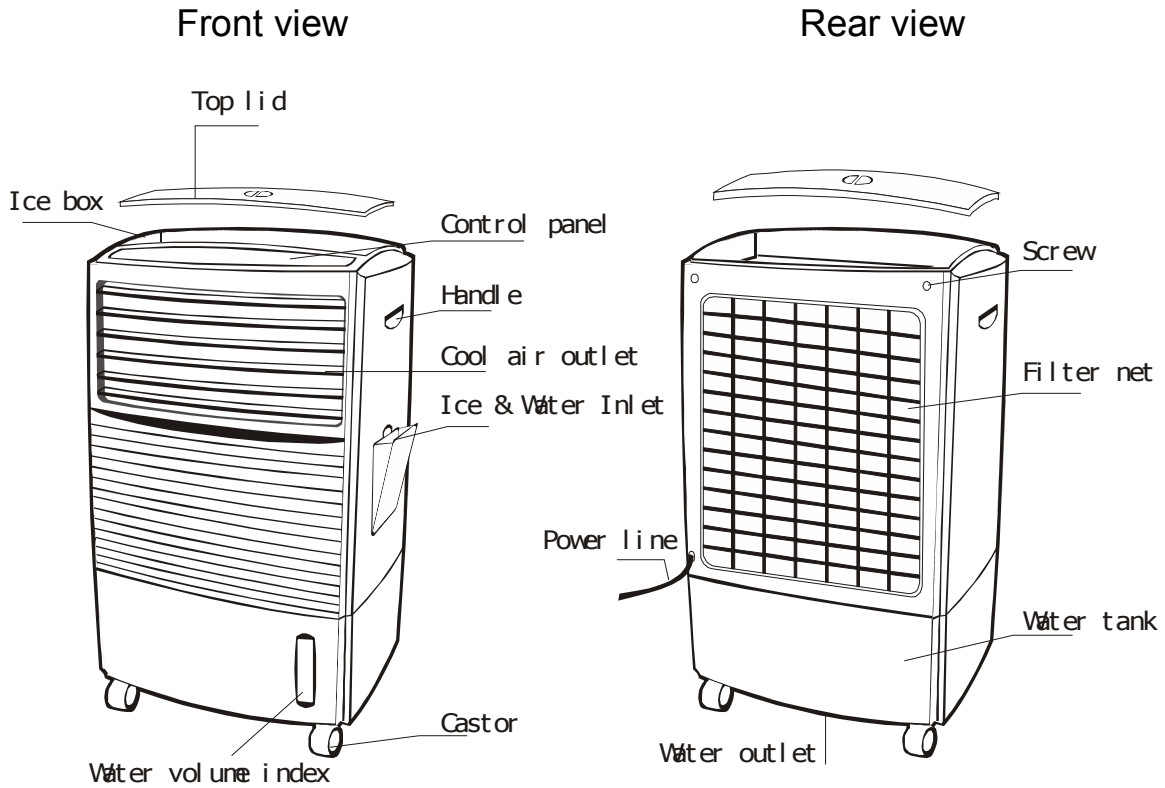

## 2. Control Panel

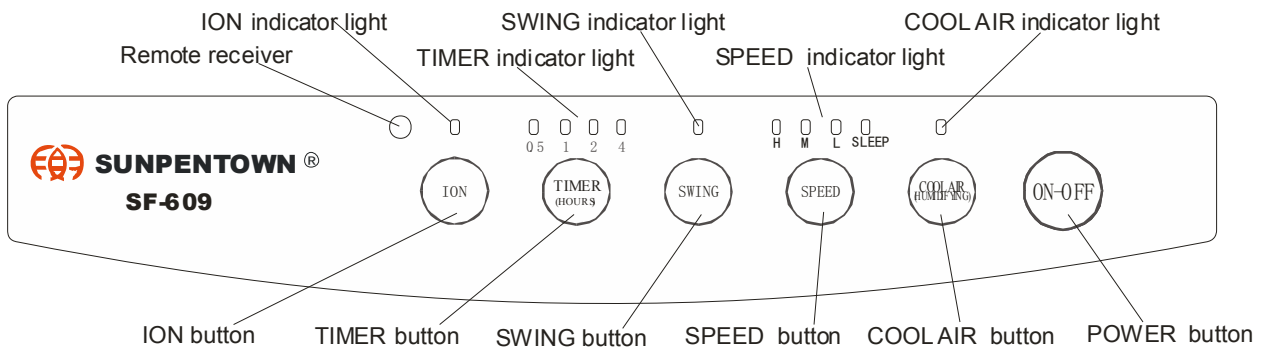

## Important Safety Notes

1. Make sure the correct power (120V/60 Hz) is supplied.
2. To avoid electric shock or personal injury, do not operate any appliance with a damaged cord or plug or after the appliance malfunctions or has been damaged in any manner. Return the unit to Sunpentown (see warranty) for examination, repair or adjustment.
3. Unplug the appliance when not in use and before maintenance or servicing.
4. The applicable temperature to run this unit is between 32°F-104°F. Do not operate when the temperature is above or below this range. Do not let unit sit under direct sunlight.
5. When the tank is full, move unit from the side slowly to prevent water from spilling.
6. Do not place heavy objects on the machine.
7. Close supervision is necessary when any appliance is used by or near children.
8. When unplugging, pull from the plug and not on the cord.
9. Turn off the unit when adding water.
10. Turn off and unplug unit before cleaning.
11. To avoid excessive dampness, do not use the humidifying function for an extended period of time in an area with poor circulation.
12. When not planning to use the unit for a long period of time, please unplug the power cord, drain water, and store in a cool, dry place.
13. Please change water often to keep the water tank clean. It is recommended to change the water once every 1 ~ 2 days.

## Operation

Please fill the water tank as instructed below before turning on the unit.

Operating instructions:

1. **ON/OFF** button

Press once to turn ON unit, the “H” indicator light of “SPEED” mode will be on.  
Press again to turn OFF unit.

2. **SPEED** button

When turned ON, the unit starts on High (the “H” indicator light is on), to adjust:

- Press once for Medium speed (the “M” indicator light is on)
- Press again for Low speed (the “L” indicator light is on)
- Press again for High speed with Sleep mode (the “H” and “SLEEP” indicator lights are on). Unit will operate in High speed for 2 min, Medium speed for 1 min, and back to High for 2 min. and so on for approx. 30 minutes. After which the unit will switch to operate in Medium speed for another 30 minutes and finally switch to Low speed. Unit will run in Low speed until powered OFF.
- Press again for Medium speed with Sleep mode (the “M” and “SLEEP” indicator lights are on). Unit will run in Medium speed for 2 min, Low speed for 1 min, and back to Medium for 2 min. and so on for approx. 30 minutes. After which, the unit will switch to Low speed and continues in Low until powered OFF.
- Press again for Low speed with Sleep mode (the “L” and “SLEEP” indicator lights are on). Unit will operate in Low speed for 2 min, stop 1 min, and back to Low for 2 min. and so on. Unit will continue to run in this mode until powered OFF.
- There are total of six different settings to choose from.

- To avoid catching a cold while sleeping, the Sleep mode will automatically decrease the fan speed slowly. **Timer can also be used in Sleep mode.**
3. **SWING** button  
Press the SWING button to select the swinging function:
    - Press once to turn on the swinging function (indicator light is on), which can cover 60° horizontally
    - Press again for fixed direction (indicator light is off)
  4. **TIMER** button  
Each press of the timer button will add 0.5 hour to the timer until it reached the maximum of 7.5 hours. Adding the numbers indicated equals the total time for the timer. For example: when the 0.5 and 1 indicators are on at the same time, it means the timer has been set for 1.5 hours; when the 0.5, 1, 2 and 4 indicators are on at the same time, the timer has been set for 7.5 hours. If none of the timer indicators are on, the unit will run continuously.
  5. **COOL AIR (HUMIDIFYING)** button
    - Press once to turn on the water pump, press again to turn off the water pump
    - If the water level is above “MIN”, the red indicator light will turn on and the pump will start working. After 3 ~ 5 minutes, the unit will send out moist and comfortable cool air.
    - If the water level is below “MIN” or if the water tank is empty, please do not turn on this function. The unit will beep 5 times and the red indicator light will be flashing to warn that the water tank is low/empty and the pump will NOT work.
    - While operating in Cool Air / Humidifying mode, when the water tank reaches half point, the unit will beep **5 times** to warn you that the water tank is half empty. The red indicator light remains on and the unit continuous running.
    - To prevent damage to the water pump, when operating the unit without water, please keep the Cool Air / Humidifying function OFF. The unit will operate as a normal electric fan.
  6. **ION** button
    - **Press once to turn the ION function on (indicator light is on)**
    - **Press again to turn ION function off.**
  7. **WATER FILLING INSTRUCTIONS**
    - Please be sure the power is OFF before filling water.
    - Fill the water tank by pouring water and adding ice into the Ice & Water Inlet.
    - Amount of water added can be seen from the water indicator located at the bottom front.
    - Make sure the water indicator indicates the water level is above “MIN”.
    - Pour in 2/3 of water (6 Liters) and 1/3 of ice (3 Liters) for best cooling effect.
    - You can also put some ice or ice packs in the “Ice Box” located on the top of the unit for extra cooling (optional).
    - DO NOT add more than 10 Liters of water into the water tank. The water indicator light should never rise above “MAX” or the water tank will overflow.

**NOTE: When operating the unit for the first time, please add water to the “MAX” level.**

# Specifications

Model	Rated Voltage	Rated Frequency	Rated Power	Water Consumption	Water Tank Capacity	Speed	Dimensions	N.W.
SF-609	~120V	60Hz	60W	0.6-0.7L/h	10L	7m/s	5.4"x11.8"x25.2"	16.5lb

## Circuit diagram

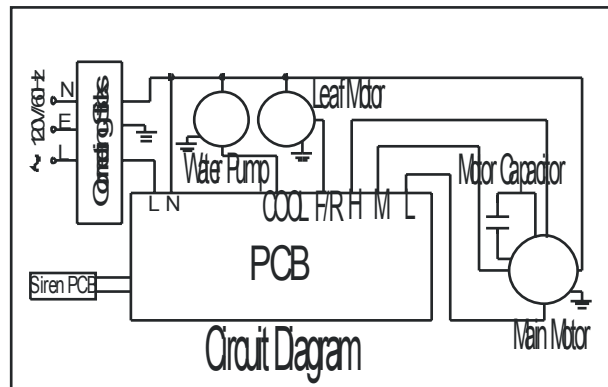

## Maintenance

### Cleaning the filter net and water tank

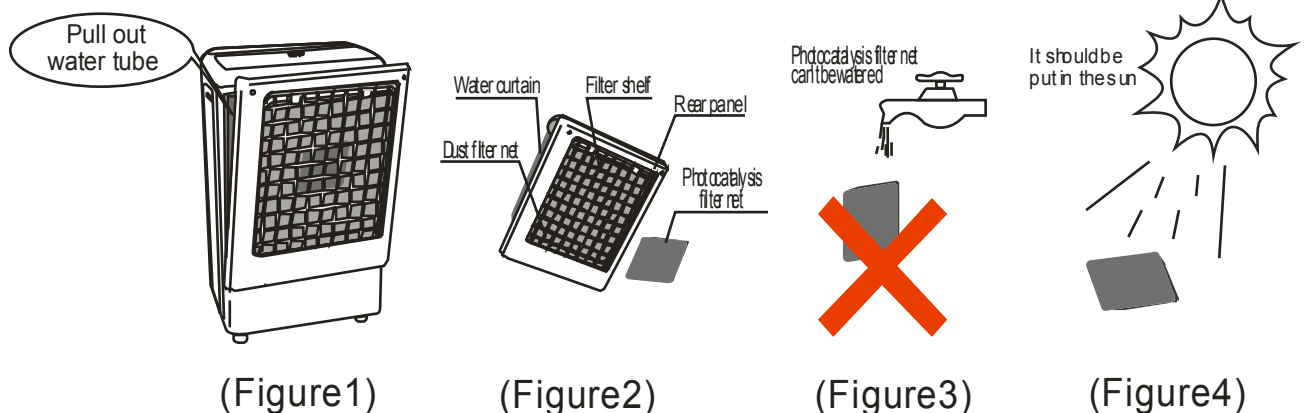

To ensure best humidifying and purifying effect, please clean the filtration system once a week.

1. Pull the dust filter net upwards from opening slot of filter shelf
  2. Remove the photo-catalysis filter net (small black filter)
  3. Rinse the dust filter net with clean water and allow to dry
  4. Replace the photo-catalysis filter net and insert the dust filter net back in place
- Do not wet the photo-catalysis filter (figure 3), insolate it in the sun (figure 4)

# Troubleshooting

Problem	Reasons	Solution
Not blowing air	<ul style="list-style-type: none"> <li>• Power is not turned on</li> <li>• Timer fulfilled</li> <li>• Unit is broken/defective</li> </ul>	<ul style="list-style-type: none"> <li>• Turn on power</li> <li>• Switch off Timer mode</li> <li>• Contact Sunpentown</li> </ul>
Unit will not turn off	<ul style="list-style-type: none"> <li>• "On/Off" button not pressed</li> <li>• Unit is broken/defective</li> </ul>	<ul style="list-style-type: none"> <li>• Press the "On/Off" button</li> <li>• Contact Sunpentown</li> </ul>
Unit makes noise	<ul style="list-style-type: none"> <li>• There are objects in it</li> <li>• Faulty motor</li> <li>• Air wheel/fan is loose</li> </ul>	<ul style="list-style-type: none"> <li>• Take off rear panel and filter net, remove foreign object(s)</li> <li>• Contact Sunpentown</li> <li>• Contact Sunpentown</li> </ul>
Not humidifying	<ul style="list-style-type: none"> <li>• Water level low/empty</li> <li>• Faulty water pump</li> </ul>	<ul style="list-style-type: none"> <li>• Add water to Maximum level</li> <li>• Contact Sunpentown</li> </ul>
No swing	<ul style="list-style-type: none"> <li>• "Swing" button not pressed</li> <li>• Faulty leaf motor</li> </ul>	<ul style="list-style-type: none"> <li>• Press the "Swing" button</li> <li>• Contact Sunpentown</li> </ul>

## Your Guarantee

If this product is found to be faulty as a result of faulty materials or workmanship within one year from date of purchase, it will be repaired or replaced free of charge.

This guarantee is subject to the following terms:

1. Sunpentown must be notified of the fault.
2. Proof of purchase must be presented to Sunpentown's nominated representative.
3. The warranty will be void if the product is modified, misused or repaired by an unauthorized person.
4. The guarantee after repair or replacement will not be extended beyond the original one-year period.
5. All replacement parts or units will be new or reconditioned.
6. Parts or units, which are replaced, become the property of Sunpentown.
7. The warranty applies for the use of the product in the USA.
8. Warranty does not include freight charges.

This GUARANTEE is in addition to your Statutory Rights.



**SUNPENTOWN INTERNATIONAL INC.**

18249 Valley Boulevard, City of Industry, CA 91744

Tel: 626-581-1818 Fax: 626-581-1398