



# USER MANUAL

---

Model: Patriot



**Non-medical Device**

This product is not a medical device and is not intended to assist, treat, diagnose or alleviate any medical condition or disability.

# How to Use This Manual

Please read the user manual carefully before taking the product into use.

- This manual applies to our model: Patriot
- This manual contains operations and assembly methods.
- This manual contains scooter maintenance and self inspection methods. Please store in proper place.
- This manual contains solutions to simple device faults.
- Please provide this manual for reference when other people are going to use this scooter.
- The annotations and illustrations in this manual might be slightly different with the real parts due to quality improvements from changing design. We thank you for your patience.
- Contact your dealer if there is any ambiguity or questions.
- Improper use of any vehicle may lead to injury. Unsafe driving could harm yourselves and others.
- The mobility scooter is intended to comfortably transport those with walking difficulties.
- This mobility scooter is designed to transport 1 person only.

I. Introduction .....	03
II. Safety Guide .....	04
III. Operation .....	05
IV. Seat Removal and Adjustment .....	10
V. Tiller, Battery and Charging.....	11
VI. Transportation.....	14
VII. Guidance for Safe Operation and Use.....	15
VIII. Battery and Charging Information .....	18
IX. General Warning .....	20
X. Specifications .....	22
XI. Routine Maintenance .....	24
XII. Trouble Shooting Guide .....	25
XIII. Warranty .....	28

# Introduction

All of our Scooters undergo rigorous tests to ensure they meet our requirements for comfort, safety and durability.

Metro Mobility is based in product quality, value and genuinely caring for our customers. We pride ourselves not only on designing and building the most innovative products, but also on our commitment to offer an excellent standard of customer service both in sale and after sale.

Before using your scooter please read this manual carefully. It will provide you with all the information you will require. However, if you have any questions about the use, maintenance or safety of your scooter, please contact your local dealer. If you have any questions regarding other areas, please write to [support@metromobilityusa.com](mailto:support@metromobilityusa.com), where our support team will catch up with you.

The scooter is intended for the use of people of all ages who may have difficulty walking for periods of time. It is ideal for outdoor use and suitable for users up to 136kg in weight, 300lbs. Differing user weights can cause performance variation. Maximum user weight was tested using a 136kg test dummy.

Electromagnetic fields, such as those emitted by shop alarms may be disturbed by the use of the scooter. The function of the scooter may also be disturbed by these electromagnetic fields.

We are dedicated to providing products of quality that fully and reliably meet the requirements of their intended use. We are BS/EN ISO 9001 accredited which is the internationally recognized standard for quality management systems. This approval ensures we provide quality in all areas of our business from development through to final delivery. Should you require any further assistance, please contact your local dealer.



**DO NOT OPERATE THE SCOOTER BEFORE READING AND UNDERSTANDING THIS INSTRUCTION MANUAL.**

**IF YOU ARE IN DOUBT ABOUT THE MEANING OF THESE INSTRUCTIONS, OR ANY OF THE CAUTIONS AND WARNINGS, PLEASE CONSULT YOUR HEALTHCARE PROFESSIONAL, DEALER OR RELEVANT TECHNICAL PERSONNEL.**

**FAILURE TO FULLY UNDERSTAND THE OPERATION OF THE SCOOTER MAY RESULT IN AN UNEXPECTED RESPONSE FROM THE EQUIPMENT WHICH CAN THEN LEAD TO POSSIBLE INJURY OR DAMAGE.**

## **NOTES**

Warning and Caution notices used in this manual apply to hazards and unsafe practices that could result in personal injury or damage to property.

## **WARNING**

We supply an extensive range of mobility scooters to meet the varying needs of individual users. It is the responsibility of the individual user and their qualified healthcare advisor, to decide which scooter is suitable for the user's intended purpose.

Regarding restraints, seat positioning straps, posture correction or other positional aids and accessories, it is the obligation of the qualified healthcare professional in conjunction with the dealer to ensure the suitability of such equipment for the safe operation of the scooter.

Serious injury can occur in the event of a fall from a mobility scooter. We **DO NOT RECOMMEND** that a scooter user is transported in any type of vehicle when seated in the scooter.

At this time, there are no approved Tie-down Systems for the transportation of a user in ANY moving vehicle whilst seated in a scooter. It is our opinion that users of mobility scooters should be transferred into the appropriate vehicle seating with proper restraints for transportation.

## **Intended Use**

The intended use of the device is for people who can barely walk but have the ability to operate a mobility scooter.

## PARTS DESCRIPTION

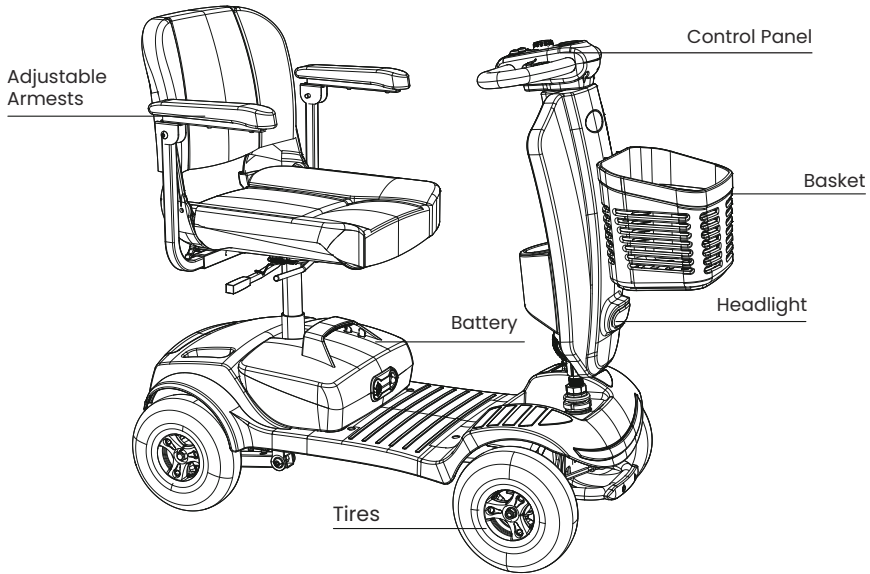

## CONTROL PANEL

All of the drive controls for the scooter are to be found on the tiller control box.

1. Battery Gauge
2. Speed Knob
3. Throttle Control Lever
4. Light Switch
5. Horn Button

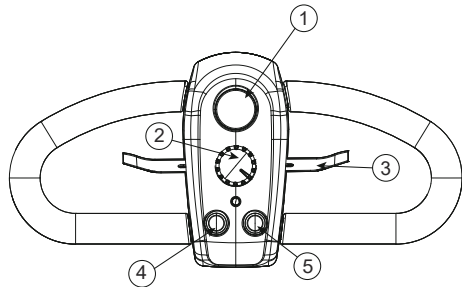

## The Preset Speed Knob

Turning this knob to the left, reduces your available maximum speed.  
Turning it to the right, increases the available maximum speed (**see figure 1**).

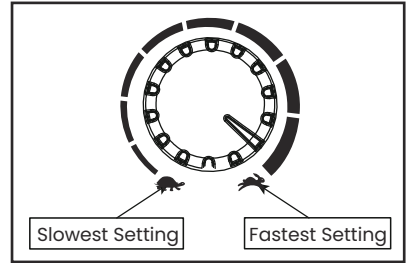

Figure 1

## The Battery Gauge

This gives an approximation of battery charge and is illuminated for clarity. The gauge is “RED” empty, to “YELLOW” charge required, to “GREEN” charged.

LEDS	BATTERY PERCENTAGE
● ● ● ● ● ● ● ●	91-100% battery remaining
● ● ● ● ● ● ●	76-90% battery remaining
● ● ● ● ● ●	61-75% battery remaining
● ● ● ● ●	46-60% battery remaining
● ● ● ●	31-45% battery remaining
● ● ●	21-30% battery remaining
● ●	10-20% battery remaining
●	<10% battery remaining

As the scooter moves over differing terrain, it is normal for the Battery Gauge to dip up and down. For a more accurate reading, stop the scooter. The gauge will dip more often in cold and damp weather as the capacity and efficiency of all batteries drop in these conditions.

## TIP

If your battery gauge has gone into the “RED” section you can increase your remaining range by reducing your maximum speed. Remember you **MUST** charge your battery overnight as soon as you can to prevent battery damage.

## Operating the Lights

The lights are operated by pressing the blue button on the front fascia panel. Press the button once to illuminate the lights, press the button again to switch the lights off. Switch the lights on to make yourself more visible in low levels of light, day or night (**see figure 2**).

# Operation

## Throttle Lever

The throttle lever controls the speed as well as the forward and reverse motion of the scooter.

To move the scooter in a FORWARD motion, PULL the lever with the RIGHT hand or PUSH the lever with the LEFT THUMB.

To move the scooter in a REVERSE motion, PULL the lever with the LEFT HAND or PUSH the lever with the RIGHT THUMB. The lever will return when released and the scooter will slow to a stop .

The more you move the lever, the more your speed will increase (up to its preset maximum). It is possible to operate your scooter using only one side of the throttle lever. To do this simply PUSH and PULL on the chosen side of the throttle lever(see figure 3).

## Horn Button

Pressing the horn button produces an audible warning sound. Use this function to warn pedestrians of your presence when necessary (see figure 4).

## Key Switch

The key switch switches the scooter ON and OFF.

Please note that the key cannot be removed when it is in the ON position.

Turning the key to OFF while driving will cause the scooter to stop very abruptly. This is not recommended, except in an emergency, as continual use of this function could result in damage to the scooter.

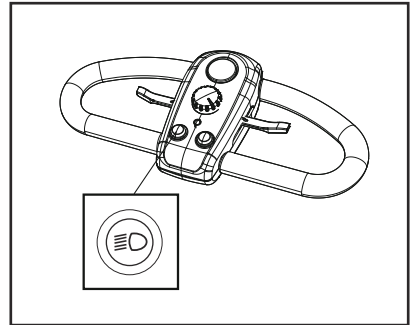

Figure 2

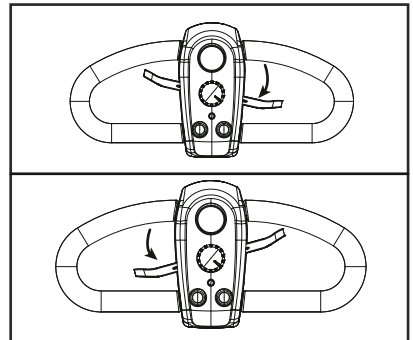

Figure 3

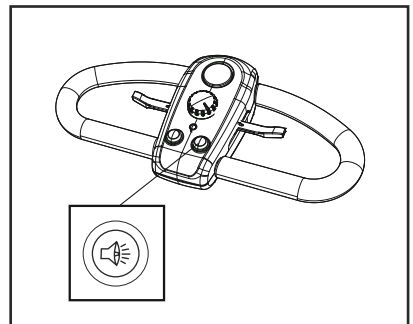

Figure 4

Make sure that the switch is in the OFF position before getting on or off the scooter. To ensure that the scooter is OFF, remove the key.

## Charging Socket

The socket to connect the charger is located on the battery pack (see figure 5 and 6). To use the socket, swivel the plastic cover to the left or right to reveal the socket connections. The charger output plug can now be connected, ready to accept charge current from the battery charger.

After use, ensure that the plastic swivel cover is rotated back into place. This action helps prevent water from entering the socket connections.

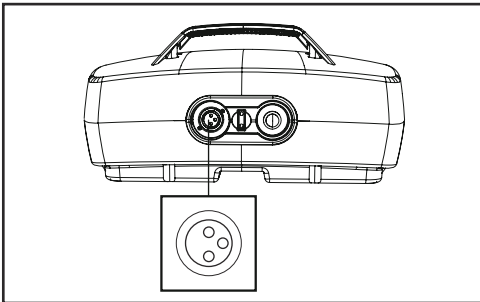

Figure 5

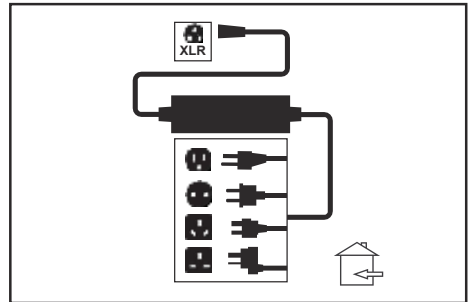

Figure 6



### WARNING

Do not attempt to charge your scooter outdoors or in damp/wet conditions. Failure to comply with this instruction may lead to a shock or fire hazard.

## Freewheel mechanism

A freewheel device disengages the engine to allow for manual operation only. By pushing the lever backward, you will engage the motor to drive again. Please make sure to power off the scooter when moving the lever from unlock to lock position. This will ensure the scooter registers the change.

The lever is located on the right hand side of the scooter rear panel (see figure 7).

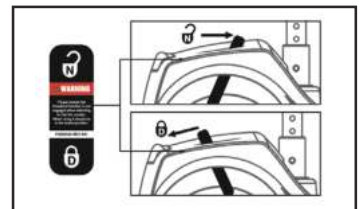

Figure 7

**WARNING**

Use extreme caution in the freewheel mode, especially on slopes/inclines. In these circumstances, letting go of your scooter will cause the scooter to roll.

Please ensure that the freewheel function is disengaged when intending to ride the scooter and that after use, it is reengaged. Failure to do so may result in injury.

# Seat Removal and Adjustment

## Removing the Seat

1. Lift armrests up for easier access to the seat lever (see figure 8).
2. Stand behind the seat and fold the backrest down (see figure 9).
3. Grab the seat base and while pulling the seat lever up, lift the seat vertically (see figure 10).
4. Place seat at desired location for stowage.

**Note:** Exercise caution when lifting the seat.

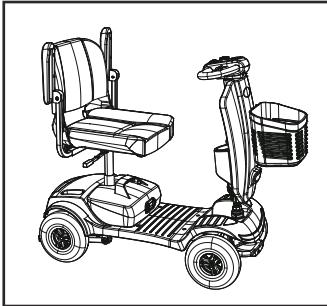

Figure 8

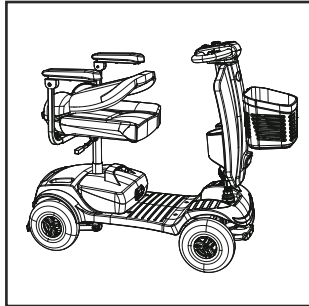

Figure 9

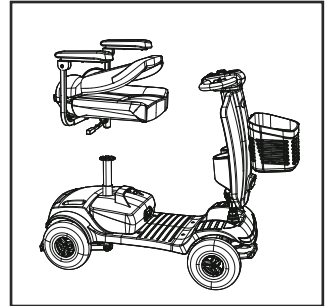

Figure 10

## Seat Height Adjustment

1. Remove the seat base as described earlier .
2. Change the seat post to the new position and refit the detent pin (see figure 11).
3. Put the seat base back on.

## Armrest Adjustment

1. Loosen the adjustable screws .
2. Move the armrests to the desired position and re-tighten the adjustable screws, changing the space between armrests(see figure 12).

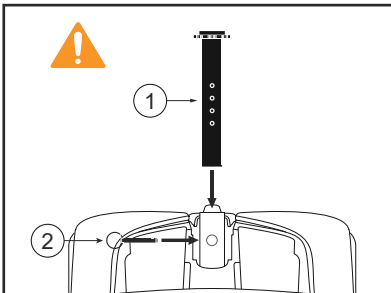

Figure 11

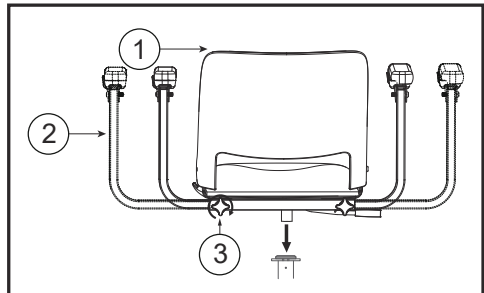

Figure 12

# Tiller, Battery and Charging

## Tiller Adjustment

The scooter features an infinitely adjustable tiller which allows you to lock the tiller in the most comfortable position for driving. This feature also lets you fold the tiller down fully, for transportation and stowage (see figure 13). The folding knob is located on the bottom of the tiller.

To adjust, support the tiller with your left hand. Rotate the folding knob counter-clockwise to release the tiller. Move the tiller to the desired location. Rotate the folding knob clockwise to lock the tiller.

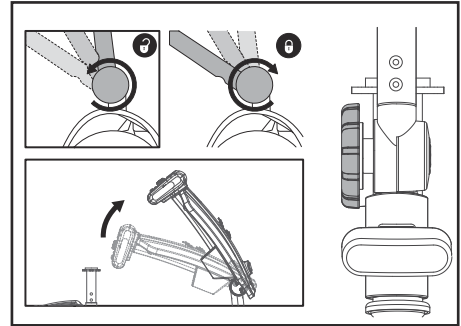

Figure 13

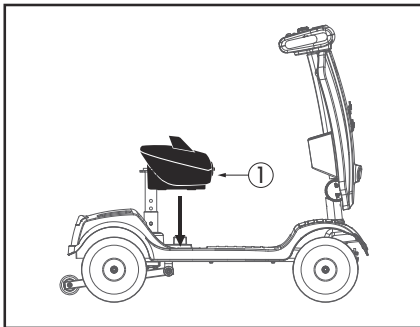

Figure 14

## Battery Removal

It is important to remove the seat base and seat post first to allow for better access to the batteries. Lift the battery vertically out of its tray using the handle provided (see figure 14).

When reassembling the scooter, remember to insert the detent pin. Failure to do so may result in being unable to take out the seat post and adjust the seat height. Ensure that the battery pack is free from dirt and grit - this will affect the performance of the battery.

## SPECIFICATIONS

Rated Voltage	12V
Rated Capacity	12.2Ah(C2, to 10.5V@25 °C)
Total Battery Length	151mm±3mm
Total Battery Width	99mm±2mm
Shell Height	98mm±2mm
Total Battery Height	103mm±2mm
Weight	3.95kg±0.2kg

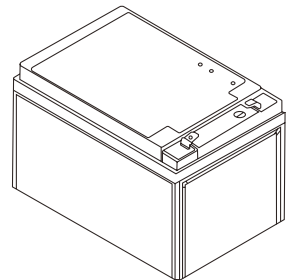



## Battery Charging

Your scooter is supplied with a charger. Please note that only chargers supplied by your local authorized dealer with a capacity of minimum 2.0 Amps and maximum of 6.0 Amps should be used. Turn off scooter before charging.

To charge, move the charger connector cover located on the battery pack and connect the charger (see figure 15). Ensure that the charger plug is dry and intact before connecting it to the scooter. A reset button is located on the battery, as well. Please check that the button is pressed in .

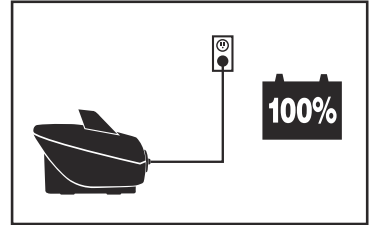

Figure 15

## Note

### Operating instructions

- Make sure that the power cord, charger and battery connector are connected.
- Check that the output voltage of the charger is the same as the connecting battery.
- Connect the plug of the charger with the battery first, and then plug the AC power plug into the electricity outlet.

### LED indications

- Red light on: Power on, disconnect with the battery
- Orange light on: Charging
- Green light on: Full-charged

### Troubles shooting

When the RED light is off despite the power being on.

- Check if the input power cord of the charger has been plugged into a proper socket, one where electricity passes from the outlet. If this is the case, the battery may be defective. please send the charger back to the manufacturer for repair.

When the ORANGE light is off while charging.

- Check if the charger and battery connectors are correctly connected and that the battery is not fully charged, if this is the case, the battery maybe defective. Please send the charger back to the manufacturer

When the ORANGE light turns to GREEN immediately.

- Check to see if the battery is fully charged, if not, the charger maybe defective, please send the charger back to the manufacturer for repair.

### Caution

For indoor use only. Do not expose to rain. Please remove charger from outlet before removing the charger from the battery. Avoid explosive gases or sparks by putting the charger in a well ventilated area when charging. Only use the charger with 24V lead acid batteries.

## WARNING!

Only use the original charger from our company. Using another brand's charger may shorten your warranty period, using an unknown charger may cause damage to your scooters, and using the wrong charger may cause a fire.

Use extreme caution to manage the battery and charger.

Don't throw the battery into the fire. Dispose of battery according to the local law.



Don't put the battery near to any heating device that may cause the battery to explode.

Don't press on the battery, stab it, or let it endure any high pressure. This may cause it to short circuit or overheat.

**DO NOT TOUCH BATTERY PACK TERMINALS WITH METAL OBJECTS. THIS INCLUDES METALLIC JEWELLERY. DO NOT EXPOSE CHARGING BATTERIES TO NAKED FLAMES OR SMOKE. REPLACE DAMAGED OR LEAKING BATTERIES IMMEDIATELY. WEAR GLOVES IF MOVING LEAKING BATTERIES.**

**IF THERE IS DAMAGE TO THE BATTERIES OR THE BATTERY BOXES, CONTACT YOUR LOCAL DEALER IMMEDIATELY. DO NOT ATTEMPT TO FIX THE BATTERIES YOURSELF.**

## Fuse

If a fault occurs, the reset button will pop out. Switch the scooter off, press the button in and switch the scooter back on (**see figure 16**).

There is a 5A fuse fitted to the positive terminal of battery.

There is also a 2.5A fuse fitted in the charger and a 2A fuse in the main plug of the battery charger. All fuses must be replaced by an authorized service agent if needed.

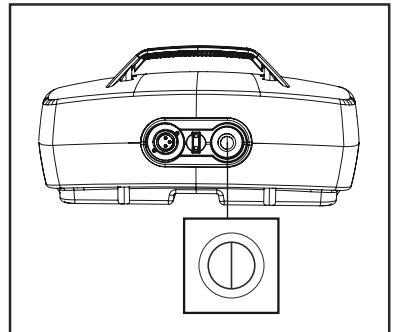

Figure 16

## Disassembling Transportation

1. Switch off the scooter
2. Remove the basket
3. Remove the seat
4. Take out the detent pin and remove the seat post
5. Using the folding knob, lower the tiller to lock into its lowest setting
6. Using the lifting handles provided, carefully lift the scooter safely and securely into the luggage compartment of the vehicle

### TIP

Please put all the parts after disassembling into the original carton from us to insure the safe transportation (see figure 17). To reassemble your scooter, simply reverse the above steps.

### Important

When reassembling the scooter, remember to properly insert the detent pin. Failure to do so may result in being unable to take out the seat post and adjust the seat height. Always secure your scooter parts before transportation. Remember to stop the scooter from moving by pushing the freewheel lever forwards. Don't sit on the scooter during transportation.

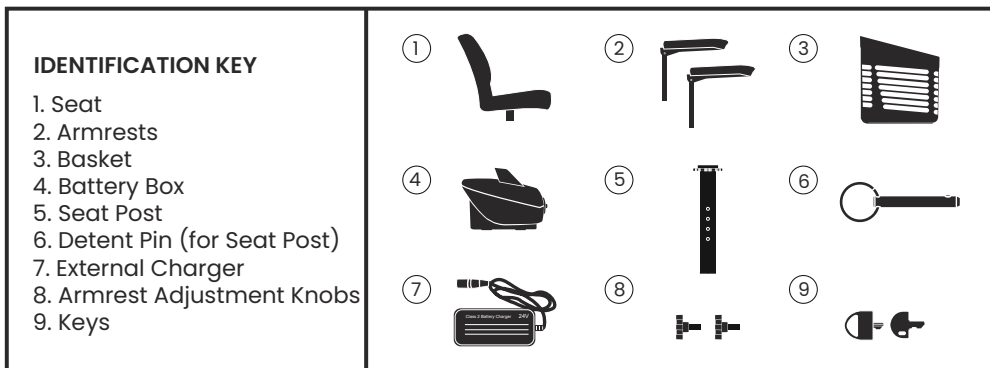

Figure 17

## Basic Driving

It is advisable, for the first few sessions of operating your scooter, that the area around you is clear of obstacles and pedestrians.

Before operating your scooter, ensure the seat height and position has been adjusted to your satisfaction and that the tiller angle has been set for optimal safety and comfort.

· To start, be properly seated on the scooter and check that the speed control knob is fully to the left. Then turn the key switch to the "ON" position .

· On the tiller, use the throttle levers as described earlier. You will gently accelerate. Release and you will gently stop. Practice these two basic functions until you get used to them.

· Steering the scooter is easy and logical. Remember to allow enough clearance when turning corners so that the rear wheels will clear any obstacles.

· Short cutting a pavement corner can cause problems to the back wheels if the corner is very rough. Avoid this at all times by steering an exaggerated curve around the obstacle.

· When steering in a tight spot, such as entering a doorway or when turning around, stop the scooter, turn the handlebar to where you want to go, then apply power gently. This will make the scooter turn very sharply. It is also recommended that the preset speed is set to a slower setting so that there is more control over the scooter.

· Reversing requires caution - especially exercise caution when reversing down slopes. When reversing, always turn the handlebars in the opposite direction to the way you want to go. The more you operate the throttle lever, the faster you will go. Reverse speed is 50% slower than forward speed. If the scooter does not move in reverse, carefully turn the speed control knob clockwise until the scooter moves gently backwards.

## Important

To preserve battery power there is a "sleep timer" feature built into the controller. Should the scooter be left ON, but not operated for 15 minutes the scooter will go into "sleep mode". To reset this, switch the scooter OFF and then back ON again.

**Note: The user's visual standards must be higher than 0.5.**

## Hill Climbing

This scooter has been tested to climb an incline of no more than 8° with a maximum user weight of up to 136kg (300 lbs) (**see figure 18**). Do not attempt to climb inclines greater than this.

Always reduce your speed when reversing on slopes. Do not attempt to reverse down hills in excess of 8°.

Do not attempt to drive with the wheels at different levels, e.g. along the footpath and road simultaneously.

Hill climbing capability and the distance travelled between battery charges will be adversely affected by things such as:

- The weight of the user.
- The use and weight of accessories
- The terrain (e.g. grass or gravel).
- The steepness of hills.
- The level of charge and the age of the batteries.
- Extremes in temperature.

**Note:** Do not traverse across the face of a slope that is greater than 8°.

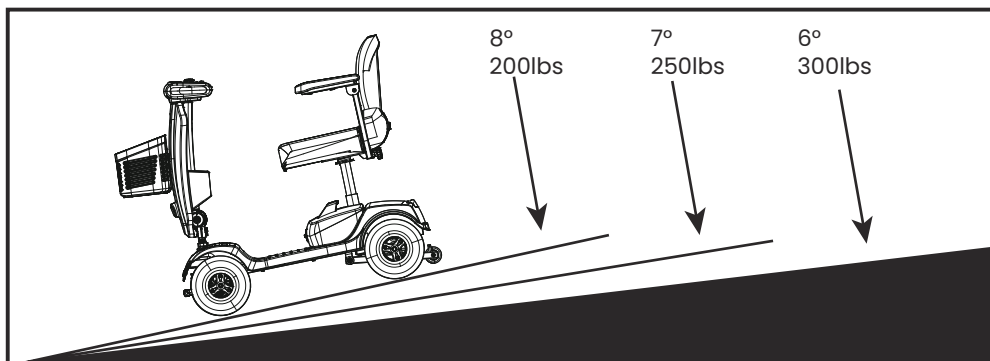

Figure 18

## Braking

To bring the scooter to a stop, simply let go of the throttle control lever (**see figure 19**).

Remember to keep both of your hands on the handlebars when the scooter is braking.

Release of the control lever will stop your scooter in seconds.

**Note:** Automatic braking is not instantaneous. It will engage within the rotation of half of a tire upon stopping.

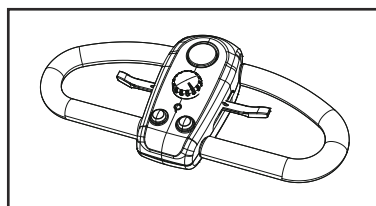

Figure 19

# Guidance for Safe Operation and Use

## Emergency Braking

In an emergency or the unlikely event of an unwanted movement of the scooter, switching off the key switch will bring the scooter to a stop. Though very effective, emergency braking is extremely abrupt and must never be used under normal circumstances.

Letting go of the throttle lever will slow the scooter to a controlled stop. **Routine use of emergency braking will cause damage to your scooter.**

## Switching off and Storage

The scooter must be switched off by the key switch. When the scooter is stowed or not in use for a long period of time, always charge the batteries for 12 hours and then disconnect the battery pack before storing at or near room temperature.

## Use on the Footpaths

When using your scooter on a footpaths, always be aware of pedestrians and situations that might require extra care. For example, those with young children and pets. Remember, especially when driving in public places, to drive with caution and regard for others at all times. When maneuvering in confined areas, including shops, ensure the minimum speed is selected. If you leave your scooter outside a shop, ensure that it does not obstruct the footpath or vehicular access.

Always switch off and take your key with you.

## Crossing roads

Your scooter is not capable of mounting and dismounting curbs and other obstacles in excess of 45mm.

Remember before crossing the road to drive forwards and position the scooter at 90° to the road, stopping about 30 - 60cm (1 - 2 feet) away from the edge of the footpath. Check that it is clear to cross. Select a medium to high speed setting and when safe to do so, drive across without stopping. Note that heavier users will require higher speed settings.

## Turning corners

Always reduce your speed when turning corners. Disregard of this advice could lead to your scooter tipping over. The anti-tip devices fitted to the scooter must not be removed. A lower speed setting is also recommended when travelling downhill or in reverse.

## Use of mobile phones

Mobile telephones or two way radio devices must not be used while operating the vehicle. Use of mobile phones or two way radios can cause excessively strong electromagnetic fields that may interfere with the vehicle's electronic systems.

If mobile phones or mobile radios are required to be used, bring the vehicle to a stop and turn off the scooter's power before such devices are used.

## Tires

Your scooter has solid tires but it is good to inspect the tires for damage or wear regularly.

# Battery and Charging Information

## General information

Batteries are the power source for almost all of the modern mobility products available today. The design of batteries used in mobility products is significantly different from other batteries. Car batteries, for example are designed to release a large amount of power over a short period of time, while mobility batteries (commonly called deep cycle batteries) release their power evenly over a long period of time. Due to the lower production volumes and increased technological requirements, mobility batteries cost more. Commonly, two 12 volt batteries are used together in a mobility product to give it a total voltage of 24 volts. The size of the battery (e.g. its available power) is expressed in amps per hour. The higher the number, the bigger the battery size and weight, allowing for a greater amount of distance you can travel (**see figure 20**).

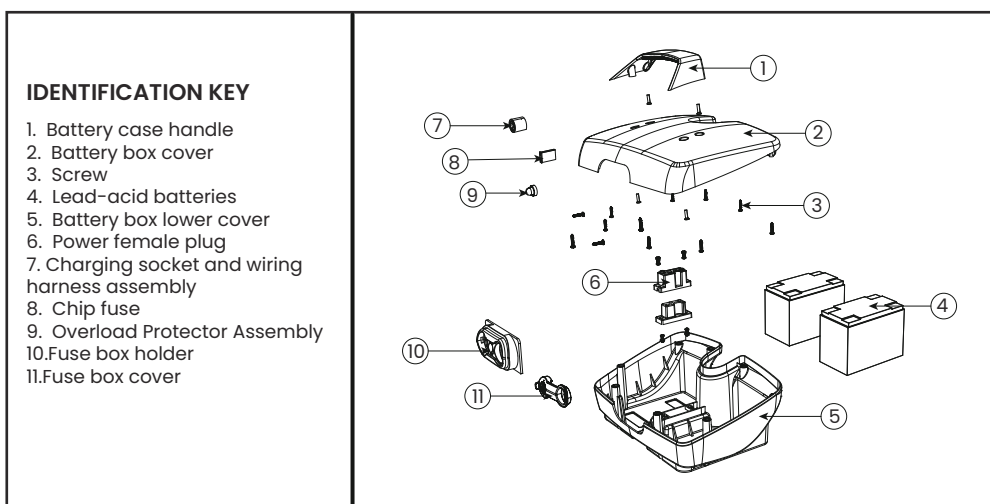

Figure 20

## Batteries

Your scooter is fitted with batteries that require no maintenance, other than regular charging.

If a battery is physically damaged, please use extreme caution when handling it.

Battery fluids are corrosive and care should be taken at all times to avoid contact with it. If it comes into contact with the skin or clothing, wash immediately with soap and water. If it comes into contact with the eye, immediately flood the eye with running cold water for at least 10 minutes and seek medical attention.

In such an event, call your local dealer for assistance.

Please do not dispose of batteries in normal waste, always recycle in accordance with local laws.

## Maintenance free

# Battery and Charging Information

This type of battery uses GEL electrolytes which are totally sealed within the battery's outer case. As the battery case is sealed, you can safely transport this type of battery without fear of acid spilling. Furthermore, they are approved for transportation on aircraft, boats and trains.

It is recommended that the batteries are always transported and stored upright. Only use batteries supplied by an authorized dealer.

## Charging Battery Care

**Do not expose any part of the battery to direct heat and when charging always place on a hard surface in a room with good ventilation. You should not charge the batteries in outdoor conditions. Do not smoke when in the vicinity of charging batteries. Clear all naked flames from the area. Do not allow the batteries to freeze. Remove all conductive jewelry before checking the battery terminals to ensure that they do not short circuit.**

## Battery Pack Care

We have set out a plan for maintenance free batteries. If these directions are not followed, this may result in lower than expected performance from your mobility vehicle.

- Only use the approved battery charger that is compatible with the vehicle.
- Charge your batteries for 8–10 hours before first time use.
- Do not interrupt the charging cycle.
- Please recharge the scooter when the battery indicator shows low. Please do not charge battery everyday if not needed.

## Range of Vehicle

Most manufacturers of mobility products state the range of their vehicles either in the sales information or within the Owner's Manual.



The range stated sometimes differs from manufacturer to manufacturer even though the battery size is the same. We measure the range of our vehicles in a consistent and uniform manner, but variation may still occur due to motor efficiencies and overall product load weight.

The range figures stated should be seen as a theoretical maximum and could be reduced if any single, or combination, of the following circumstances occur:

1. User weight heavier than 136kg (300lbs).
2. Batteries whose age and condition are less than perfect.
3. The terrain is difficult or unsuitable (e.g. very hilly, sloping, muddy ground, gravel, grass, snow and ice).
4. Thick carpets within the home can affect range, as well.
5. The ambient temperature is very hot or very cold.
6. Damage occurs to one or more tires.
7. Lots of starts and stops when driving.

**Note:** If you are out on your scooter and the battery gauge is reading low the remaining range can be increased slightly by decreasing the maximum available speed.



 <p>Never operate the scooter while you are under the influence of alcohol.</p>	 <p>Never use electronic radio transmitters such as walkie-talkies or cellular phones while operating.</p>	 <p>Make sure that there are no obstacles behind you when reversing.</p>
 <p>Do not ride your scooter in traffic.</p>	 <p>Do not ride your scooter in snow to avoid an accident from slippery roads.</p>	 <p>DO not attempt to climb, ascend, or descend ramps greater than 8 degrees.</p>
 <p>DO not make sharp turns at high speeds in forward or reverse.</p>	 <p>Do not attempt to climb curbs that are beyond the limitations stated in technical specification.</p>	 <p>DO not use an escalator to move the mobility scooter between floors as this may lead to serious bodily injury.</p>

## Personal & Operational Guidelines

Driver profiles should only be adjusted by healthcare professionals and approved agents/dealers, who are totally conversant with the process. They must also fully understand the user's capabilities and the user's ability to operate the scooter safely. Incorrect settings may cause injury or damage to the user, bystanders, the scooter and/or nearby property. To determine personal mobility limitations, practice combinations of bending, reaching, mount and dismount techniques. For users with balance problems, practice the above techniques with the aid of an assistant and in the presence of a healthcare professional.

# General Warning

Attention: Switch on the scooter lights to make yourself visible when there are low levels of light, day or night.

The rear body panel (where fitted) is designed to cover the Drive Assembly, Wiring Harness and Electrical Connectors. DO NOT stand on any of the body panels, only the foot pedal. DO NOT stand on the scooter seat.

DO NOT attempt to transfer into or out of the scooter seat without first checking that it is LOCKED into position. Attempting unsafe transfers can result in bodily injury and/or damage. DO NOT drive your scooter if the seat is not LOCKED in the FORWARD position. The seat must be secured in the FORWARD facing position BEFORE and DURING operation of the scooter. Attempting to operate the scooter with an unsecured seat could result in bodily injury and/or damage.

DO NOT operate the scooter without ensuring that the Tiller is properly adjusted and secured. To check that the tiller is locked in the correct position, gently push and pull the Tiller to make sure it is secured. An unsecured Tiller could result in bodily injury and/or damage.

If the throttle lever is released while going up an incline, a roll back will occur. In FORWARD or REVERSE motion the scooter will rollback approximately 30 centimeters (1 foot) before the brake engages.

Check that all electrical connections are secure before using your scooter. DO NOT, under any circumstances, disconnect, cut, extend or modify ANY of the wiring harnesses installed in or connected to your mobility scooter or your mobility scooter battery charger. It is important that your mobility scooter battery charger is connected to a properly installed electrical socket. Failure to comply with the above requirements could result in a possible SHOCK HAZARD.

DO NOT use any batteries that are not DEEP CYCLE GEL, AGM or SEALED LEAD-ACID type. Other types of batteries are NOT SUITABLE. Please read battery/battery charger information before installation.

Measurements are for guidance only. Small differences may occur.

PARAMETER	Patriot
LENGTH	1040mm
REAR WIDTH	510mm
HEIGHT	920mm
MAX. USER WEIGHT	136 kg (300 lbs)
BATTERY CAPACITY	12Ah
MAX SAFE SLOPE	8 degrees at 136kg
TURN RADIUS	1100mm
NARROWEST FOR TURNING	2000mm
SEAT - BASE HEIGHT	350mm
MAX SPEED	8km/h (4.97mph)
WHEEL DIAMETER FRONT	228.6mm*76.2mm
WHEEL DIAMETER REAR	228.6mm*76.2mm
CHARGER OFF-BOARD	2A
RANGE	15-25km(10-16Miles)
OVERALL WEIGHT	47kg
SEAT WEIGHT	7.3kg
BATTERY WEIGHT	9.5kg
FRONT BASKET WEIGHT	0.8kg
GROUND CLEARANCE	45mm
CONTROLLER (Dynamic)	DR50-A01 (Programmable by Dealer)
Category classification A.1.4 to prevent electric shock	Internal power class
Category classification to prevent electric shock	B class
Classification of the degree of water resistance	IPX4
Safety degree when exposed to flammable gas conditions	Not AP/APG

# Specifications

Classification of operation	Continuous operation
Volts of the mobility scooter power	24VDC (2 units)
Type of power	D.C.24V

The following gives an indication as to when routine maintenance checks should be made.

## Daily

Look at the battery charge indicator on the tiller, before use, to ensure batteries were charged.

## Weekly

Use a damp soft cloth and mild detergent on panels, battery wells, tiller and seat. Each tire should be free of debris, oil, deep cuts, or distortion. Please ensure that the batteries are charged for a minimum of 8 hours.

## Quarterly

Check the tires to ensure that the tread is visible and continuous.

## Annually

- Full service by dealer
- Inspection of seat swivel and seat slide
- Inspection of wiring and connectors for chafing and wear
- Inspection of battery terminals
- Inspection of the parking brake
- Inspection of stabilizer wheels for wear
- Inspection of motor brushes

## Storage

When storing your scooter for long periods (in excess of one month), charge the batteries for 8 hours and then disconnect to minimize battery discharge.

## Electronic faults

Do not attempt to investigate faults in the control box, the control pod or charger as the design and set up of these electronics is critical for your safety. Spare parts and services are available from authorized dealers.

## Replacing LED

Caution! Disconnect batteries before changing LED.

## Wheels

Wheels should only be removed and refitted by an authorized dealer.

# Trouble Shooting Guide

Sympton	Possible Cause	Solution
Shortened range	Batteries have not been charged for enough time	Charge batteries for eight hours or more
	Batteries are weak and cannot hold charge	Replace battery pack
Battery pack is not charging or the battery gauge shows it as empty after charging	Battery pack fault	Replace charger
	Charge fault	Contact local mobility dealer
	Charger loom or plug damaged	Check plugs and looms
	Loose connection	Try a wall socket in a different room
	No output from wall outlet	Unplug from wall & change fuse
	Fuse in charger's mains plug blown	Switch off and press button back in
	Reset button on the battery pack has popped out	Switch off and press button back in
	Output fuse in charger is blown	Unplug from wall and contact dealer
Charging current is too high	Faulty batteries	Replace battery pack
	Scooter switched on during charging	Turn Scooter off
No drive	Brake release lever is disengaged (unlocked)	Engage brake release lever (lock)
	Flat batteries	Charge battery pack
	Scooter is not switched on with key	Ensure the key is switched on
	Battery pack not engaged properly	Check battery pack is fully engaged onto connectors
	Charger plugged in	Unplug charger
	Reset button on the battery pack has popped out	Reset circuit-breaker button
	Disconnected loom or plugs	Check all plugs & looms
	Control system fault	Contact dealer

# Trouble Shooting Guide

Sympton	Possible Cause	Solution
Motor runs irregularly and/or noisily	Electrical malfunction	Contact dealer
	Control system fault	Contact dealer
<p><b>Do not attempt to open any parts of the scooter control system, battery pack, looms, plugs, or battery charger.</b>  <b>This is critical for your safety as there are no user serviceable parts.</b></p>		

Your scooter is fitted with a self diagnostic controller that will give a sequence of audible beeps when an error is detected. This will help you, or an authorized service agent, determine what is wrong.

Should you switch on the scooter and hear the beeps, note the number of them (a short delay separates each sequence). Then, refer to the table.

Number of beeps	Represent	Possible cause	Solution
1 ■	Battery power low	Not enough power	Battery needs harging
2 ■ ■	Low battery voltage	Not enough power	Battery needs harging
3 ■ ■ ■	High battery voltage	Voltage is too high when overloading or climbing	Decrease speed while climbing
			Check battery connection
4 ■ ■ ■ ■	High electric current	Electric current is over the limit of the motor	Check motor and relative wiring connections
			Switch off and wait a few minutes and Switch on.
5 ■ ■ ■ ■ ■	Freewheel level issue	The freewheel level is on	Please power off scooter
			Confirm the rear lever is in the locked position then turn on the scooter
6 ■ ■ ■ ■ ■ ■	Issue with accelerate variable resistor	Accelerate variable resistor is not in the neutral position	Make sure the accelerate variable resistor is on the neutral position
			Decrease speed while climbing

# Trouble Shooting Guide

Number of beeps	Represent	Possible cause	Solution
7 ■ ■ ■ ■ ■ ■ ■ ■	Speed limit resistor issue	Accelerate variable resistor, Speed limited variable resistor or other wiring issue	Check all the accelerate variable resistor, Speed limited variable resistor or other wiring
8 ■ ■ ■ ■ ■ ■ ■ ■ ■	Motor voltage issue	Motor and other relative wirings issue	Check Motor and other relative wirings
9 ■ ■ ■ ■ ■ ■ ■ ■ ■ ■	Other issues	Some inner issues in the controller	Check all the connection and wirings



## **One-year limited warranty**

Drivetrain parts (transaxle, motor and brake), all electrical parts, including controllers and battery chargers are covered for one year under warranty.

Any attempt to open or dismantle these parts will lead to this warranty being void.

## **Half year limited warranty**

Batteries are covered by a six-month warranty from the original manufacturer.

## **Not covered under warranty**

The following are classed as wear items, which may, under normal wear and tear, require replacing. The items that are not covered under warranty include tires, seat belts, bulbs, upholstery, plastic shrouds, motor brushes, and fuses.

Warranty will also be refused if damage is deemed to have been caused through misuse or an accident for which Metro Mobility cannot be deemed responsible.

**NOTE: Metro Mobility provides parts only under warranty. Your authorized Metro Mobility dealer is responsible for labor and services.**

**Please contact your authorized Metro Mobility dealer for information on these services and for any applicable charges.**

**Your local service agent:  
Metro Mobility USA LLC  
Address: 159 Liberty Ave, Mineola, NY, 11501  
Metro Support Team  
888-616-3876  
Support@metromobilityusa.com**