

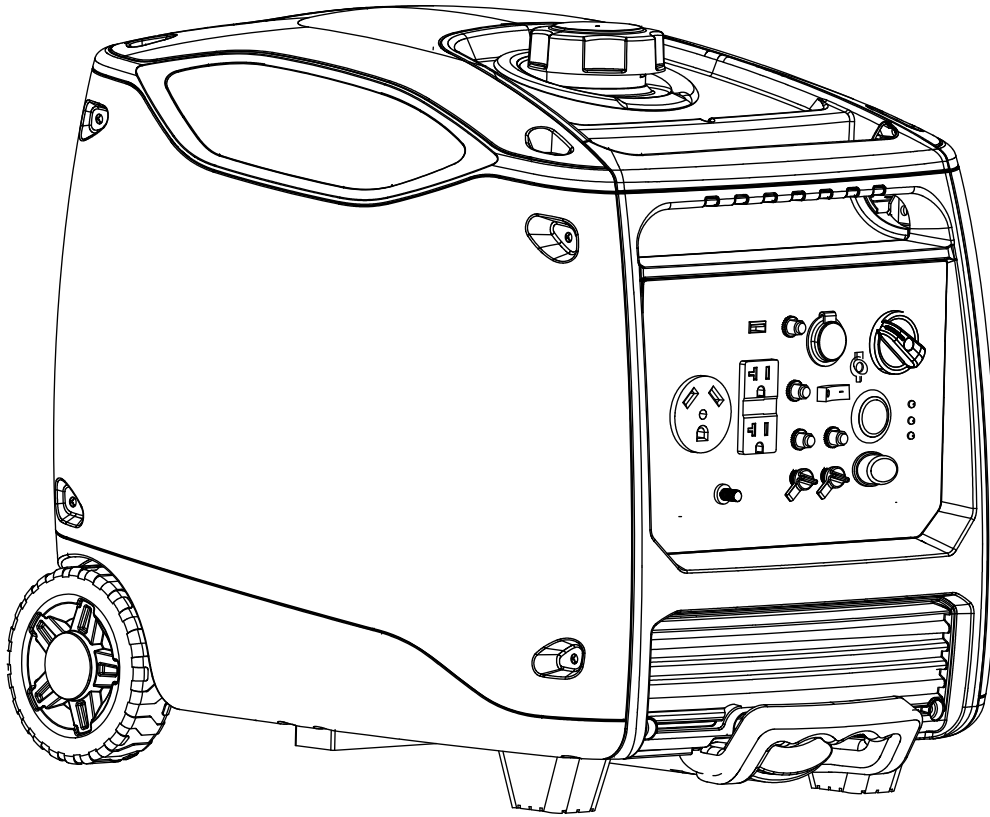

Model: PG4500iSR

Inverter Generator - Gasoline
OPERATOR'S MANUAL



Warning: The Engine Exhaust from this product contains chemicals known to the State of California to cause cancer, birth defects or other reproductive harm.

support@pulsar-products.com

TABLE OF CONTENTS

Introduction	3
Product Specifications.....	3
Parts Ordering / Customer Service.	3
Safety Rules	4
Safety Symbols	4
Safety Instructions	4
Features	7
Control Panel Functions	8
Fuel Valve Knob.....	8
USB Power Outlet.....	8
Indicator Lights.	8
DC Circuit Breaker.....	9
Engine “Economy” Control	9
Parallel Connections.....	10
Ground Terminal.	10
Assembly	11
Connecting Generator to a Building Electrical System.....	11
Adding Fuel.	11
Checking/Adding Oil	12
Operation	13
How to Start Engine.	13
How to Stop Engine.	14
Attaching Electrical Devices.	14
Charging a 12 Volt Battery.	15
AC Parallel Operation.	16
Do Not Overload Generator.	17
Wattage Reference Guide.	17
Maintenance	18
Maintenance Schedule	18
Checking Spark Plug	19
Changing Oil	20
How to Clean Air Filter.	21
Checking Muffler and Spark Arrestor	21
How to Clean Fuel Filter	22
Transport & Storage	22
Troubleshooting	24
Wiring Diagram	25

INTRODUCTION

Thank you for purchasing this superior quality portable generator from Pulsar Products, Inc. When operating and maintaining this product as instructed in this manual, your generator will give you many years of reliable service.

Product Specifications:

This generator is an engine-driven, revolving field, alternating current (AC) portable generator. It is designed to supply electrical power to operate tools, appliances, camping equipment, lighting, or serve as a backup power source during power outages.

AC Output	Rated AC Voltage	120V
	Rated Frequency	60Hz
	AC Current	20A Duplex & 30A RV
	Rated Output	3700W
	Maximum Output	4500W
DC Output	USB Outlet	5V DC 2.1A
	Cigarette Outlet	12V DC 8A
Engine	Displacement	224cc
	Engine Type	Single cylinder, 4 Stroke, OHV, Air Cooled
	Engine Oil Type	SAE 10W30
	Engine Oil Capacity	600ml / 20.2 oz.
	Fuel Tank Capacity	12L / 3.17Gal

The emissions control system for this generator is compliant with all standards set by the US EPA.

How to contact us:

To order parts, receive warranty assistance, or other service inquiries, you may contact us via our website at www.pulsar-products.com or write to us at:

PULSAR PRODUCTS, INC.
5721 E. SANTA ANA ST.
ONTARIO, CA 91761
866-591-8921

Record the following information below for service or warranty assistance.

Date of Purchase:	
Model Number:	
Serial Number	

SAFETY RULES

Safety Symbols



WARNING!

Indicates a potentially hazardous situation, which will result in serious injury or death if not avoided.



CAUTION!

Indicates a potentially hazardous situation, which could result in damage to equipment or property.



Toxic Fumes



Risk of fire



Risk of explosion



Risk of electric shock



Hot surface



Lifting hazard

Safety Instructions

The manufacturer cannot anticipate every possible hazardous circumstance that the user may encounter. Therefore, the warnings in this manual, on tags, and on affixed decals are not all-inclusive. To avoid accidents, the user must understand and follow all manual instructions and use good common sense.



WARNING!

Read and understand this manual in its entirety before operating this generator. Improper use of this generator could result in serious injury or death.



WARNING!



Do not operate indoors or in a confined space that prevents dangerous carbon monoxide gas from dissipating.

- Using a generator indoors **CAN KILL YOU IN MINUTES!**
- Carbon monoxide gas is a poisonous, odorless gas that can cause headache, confusion, fatigue, nausea, fainting, sickness, seizures, or death. If you start to experience any of these symptoms, **IMMEDIATELY** get fresh air and seek medical attention.
- Never use indoors, in a covered area, or in a confined space, even if doors and windows are open.
- Install a battery-operated carbon monoxide alarm near bedrooms.
- Keep exhaust from this unit from entering a confined area through windows, doors, vents, or other openings.
- When working in areas where vapors could be inhaled, use a respirator rated for carbon monoxide protection.



WARNING!

Engine exhaust contains chemicals that can cause cancer and birth defects.

- Always wash hands after handling generator.



WARNING!



To reduce the risk of serious injury, do not attempt to lift the generator alone.

SAFETY RULES



WARNING!

Never exceed generator's wattage/ampere capacity. This could damage the generator and/or connected electrical devices.

- Check operating voltage and frequency requirements of all electrical devices prior to plugging in to generator.



WARNING!

Never start or stop engine with electrical devices plugged in to the receptacles. Failure to comply could damage the generator and/or connected electrical devices.

- Always start the engine and let it stabilize before connecting any electrical devices.
- Disconnect all electrical devices before stopping the engine.



WARNING!

Starter recoil and other moving parts can catch on clothing, jewelry, and hair.

- Do not wear loose clothing or loose gloves.
- Remove jewelry or anything else that could be caught in moving parts.
- Tie back hair, or wear protective head covering to contain long hair.



WARNING!



Keep engine away from flammable objects and other hazardous materials.

- The fuel and its vapors used to power this unit are highly flammable and could explode resulting in serious injury or death.
- Never fill or drain fuel tank indoors.
- Never overfill fuel tank. If fuel spills, move the unit at least 30 feet away from the spill and wipe up any remaining fuel on the unit before starting the engine.
- Never smoke while operating or fueling this unit.
- Never operate or store this unit near an open flame, heat, or any other ignition source.
- Generator should be far away from buildings or other equipment during operation.
- Keep engine free of grass, leaves, or grease and other flammable debris.
- When adding or draining fuel, unit should be turned off for at least 2 minutes to cool before removing fuel cap. If unit has been running, the fuel cap may be under pressure, remove slowly.
- To keep fuel from spilling, secure unit so it cannot tip while operating or transporting.
- When transporting unit, disconnect the spark plug wire and make sure the fuel tank is empty with the fuel shutoff valve turned to the off position.



Pull cord recoils rapidly and can pull arm towards engine faster than you can let go which could result in injury.

- To avoid recoil, pull starter cord slowly until resistance is felt; retract, then pull rapidly.



WARNING!



Avoid contacting hot areas of this unit.

- Use caution around the muffler, cylinder, and other engine parts, as they can be extremely hot.
- Allow hot components to cool before touching.

SAFETY RULES



WARNING!



This generator produces high voltage which could result in burns or electrocution causing serious injury or death.

- Never handle the generator, electrical devices, or any cord while standing in water, while barefoot, or when hands or feet are wet.
- Always keep the generator dry. Never operate generator in rain or under wet conditions.
- Use a ground fault circuit interrupter (GFCI) in a damp or highly conductive area, such as metal decking or steel work.
- Never plug electrical devices into generator having frayed, worn, or bare wires. Never touch bare wires or contact receptacles.
- Never permit a child or unqualified person to operate generator. Always keep children a minimum of 10 feet away from the generator.
- If using the generator for backup power, notify the utility company.
- If connecting generator to a building's electrical system for standby power, you must use a qualified electrician to install a transfer switch. Failure to isolate the generator from the power utility could result in serious injury or death to electric utility workers.



WARNING!



Generator must be properly grounded to prevent electrocution.

- Only operate generator on a level surface.
- If connected to a structure, connect the ground terminal on the frame to an appropriate ground



WARNING!

Never modify this unit in any way or modify governed speed.

- Increasing governed speed is dangerous which can result in personal injury and/or damaged equipment.
- Decreasing governed speed adds an excessive load and can damage equipment.
- Only when operating at the preset governed speed this generator will supply the correct rated frequency and voltage.



WARNING!

Only use this unit as intended or serious injury or death could result.

- Do not bypass any safety device. Moving parts are covered with guards. Make sure all protective covers are in place.
- Never transport or make adjustments to this unit while it is running.
- Never insert objects through cooling slots.



WARNING!

Never operate this unit if there are any broken or missing parts and only use Pulsar replacement parts specifically designed for this unit.

- Improper treatment of generator can damage the unit and shorten its life.
- Always repair this unit as specified in this manual. If you have any questions, contact your dealer, or consult a qualified service center.
- Shut generator off if electrical output is missing, unit vibrates excessively or begins to smoke, spark, or emit flames.

PROP 65 WARNING: This product contains chemicals known to the state of California to cause cancer and birth defects or other reproductive harm.

FEATURES

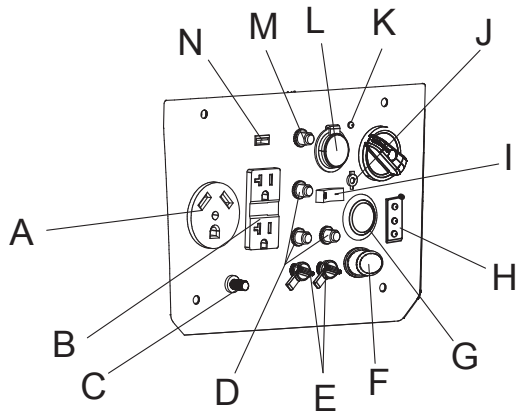

- A - 120 Volt 30 Amp RV Receptacle (TT-30)
- B - 120 Volt NEMA-5 Receptacle
- C - Ground Connection
- D - Circuit Breaker
- E - Parallel Connection
- F - Economy Switch
- G - One Push Start
- H - Generator Status Lights
- I - Battery ON/OFF Switch
- J - Charging Port - Internal Battery
- K - Start Indicator
- L - 12V CLA Power Port
- M - DC Circuit Breaker
- N - 5V DC USB 2.1A Outlet

- O - Fuel Tank Cap
- P - Engine Service Panel
- Q - Never Flat Wheels
- R - Telescoping Handle
- S - Recoil Handle
- T - Oil Access Cover
- U - Carry Handles

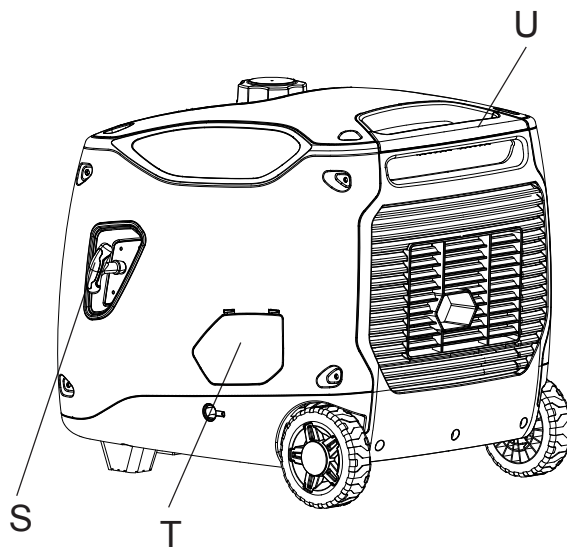
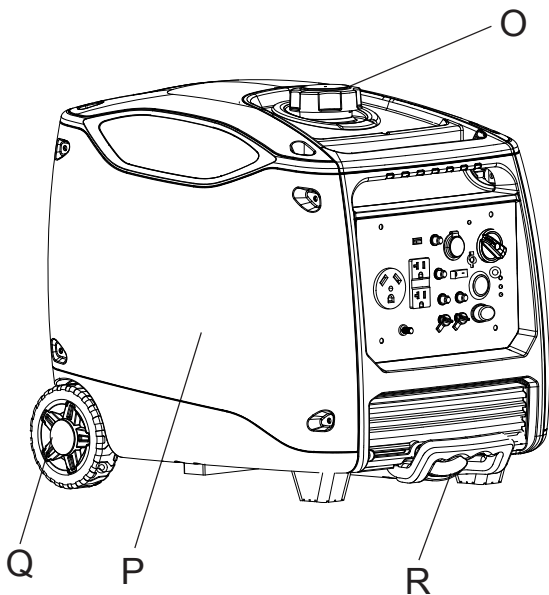

CONTROL PANEL FUNCTIONS

FUEL VALVE Knob

When the knob is in the “OFF” position, the fuel valve is closed and the engine will not run.

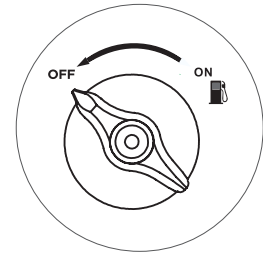

When the knob is in the “ON” position, fuel valve is opened and the engine can run.

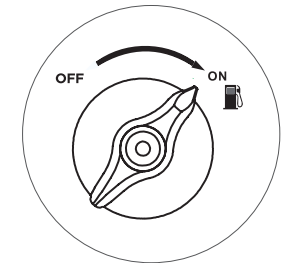

USB Power Outlet

The Generator offers a convenient (5V DC 2.1A) USB Power Outlet to allow charging of USB chargeable devices like Tablets, MP3 players, GPS, Digital Cameras and other USB chargeable devices.

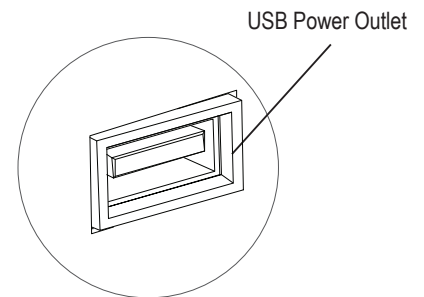

Oil Warning Indicator Light

When the oil falls below the minimum level, the oil warning indicator light comes on and the engine stops automatically. The engine will not start until the correct volume of oil is in the crankcase.

Engine Overload Indicator Light

If the engine overload indicator light comes on, the generator's wattage / amperage capacity has been exceeded by connected electrical devices or by a power surge. When this occurs, the green AC Pilot Indicator Light will go off. The engine will continue to run, (but the red Engine Overload Indicator Light will stay on and power will no longer be supplied to connected electrical devices.)

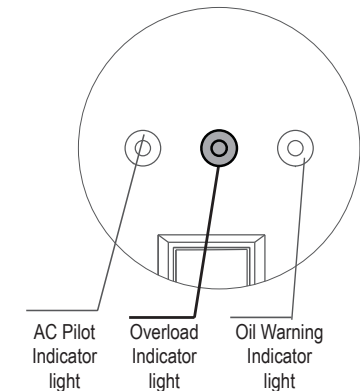
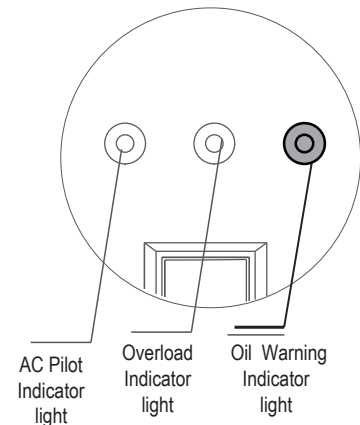

Note : The engine overload indicator light may turn on for a few seconds when attaching a load due to a power surge. This is normal.

CONTROL PANEL FUNCTIONS

How to Correct

1. Disconnect any electrical devices then stop the engine.
2. Reduce the total wattage of connected electrical devices until it is within the generator's rated output.
3. Inspect the Air Inlet and Control Panel for any blockage. Remove blockage if found.
4. Restart Engine.

AC Pilot Indicator Light

The green AC Pilot Indicator Light comes on when the engine starts and generates power.

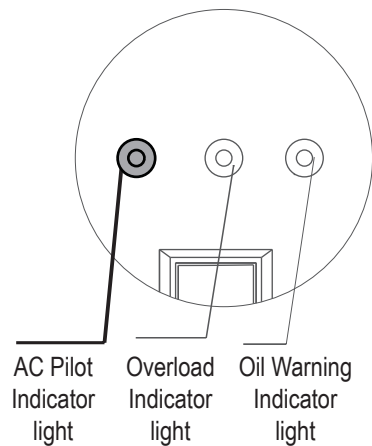

DC Circuit Breaker

When the DC Circuit Breaker is in the "I" position, the generator is able to supply power to connected electrical devices. When the DC Circuit Breaker shifts to the "O" position, the generator will no longer supply power. The DC Circuit Breaker automatically shifts to the "O" position when connecting electrical devices to the generator that exceed the generator's rated DC output. If the DC Circuit Breaker shifts to the "O" position, reduce the load of connected electrical device until the load is within rated DC output. To re-establish power, shift breaker to the "I" position.



CAUTION!

If the DC Circuit Breaker shifts to the "O" position, stop using the generator immediately and consult a qualified electrician or small engine repair shop.

Engine Economy Control

- When the engine economy switch is in the "ON" position, the economy control unit automatically determines the generator's proper engine speed based on the connected electrical load. This results in superior fuel economy and reduces noise.
- When the economy switch is in the "OFF" position, the engine will maintain a nominal speed of of 3,100 r/min.

CONTROL PANEL FUNCTIONS

Note: The economy switch must be moved to the “OFF” position when using electrical devices that require a large starting current, such as an air compressor.

Parallel Connections

Located just above the Ground Terminal, the generator's Parallel Connections enable a user to run two PG4500iSR generators simultaneously. This feature requires special cables and a parallel kit. When operating generators in parallel, the rated output is 7.4kVA and the rated output is 61.6A/120VAC. To operate generators in parallel consult a PULSAR dealer for a PARALLEL OPERATION CABLE KIT



WARNING!

Never connect generators that are different models.

- Only connect this generator to another PG4500iSR Inverter Generator.
- Only use a parallel operation cable kit designed to work with this Generator.

Fuel Tank Cap

Turn counterclockwise to remove the fuel tank cap.

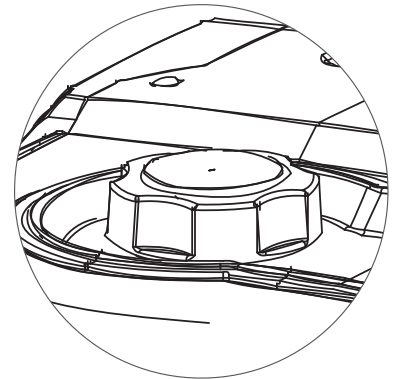

Grounding the Generator

This portable inverter generator is equipped with a terminal for the connection of a ground electrode conductor where a grounding electrode system is required by NEC Article 250.34(A). The equipment grounding conductors of the generator receptacles are bonded to the generator frame. Where the generator supplies power to cord and plug connected equipment, like power tools, the frame of the generator is not required by the NEC to be connected to an earthen ground electrode. The generator neutral conductor is bonded to the generator frame in accordance with NEC Article 250.34(C)

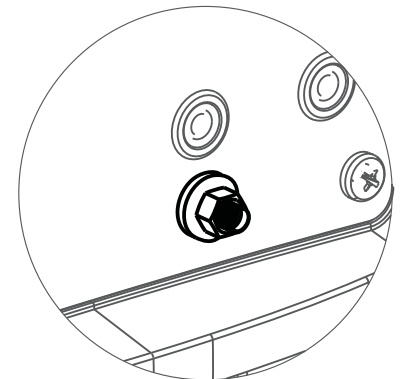

WARNING!



Generator must be properly grounded to prevent electrocution.

- Only operate generator on a level surface.
- The ground terminal **MUST** be connected to an earthen ground if the generator is connected to a structure.

ASSEMBLY

Connecting Generator to an Electrical System

- If connecting generator to a building electrical system for standby power, you must use a qualified electrician to install a transfer switch. The power from the generator must be isolated from the utility power source. The connection must comply with all local electrical codes and applicable laws.

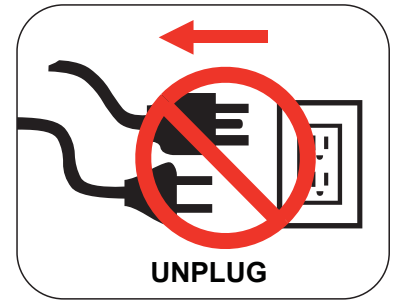

Never directly connect generator to a household power source.

Adding Fuel

- Set generator outdoors in a well-ventilated area, away from structures and people.
- Slowly remove fuel cap.
- Insert a funnel into the fuel tank and carefully pour gasoline into the tank until fuel level reaches 1 ½ inches below the top of the neck. Be careful not to overfill the tank, to allow space for fuel expansion.

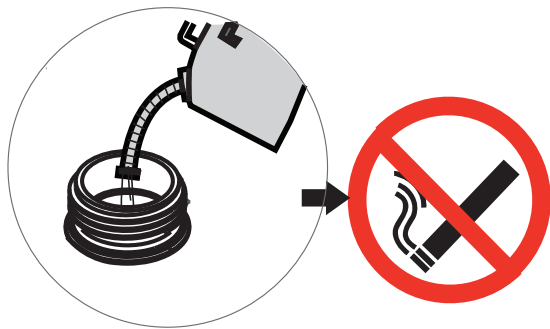

Do not smoke when adding fuel.

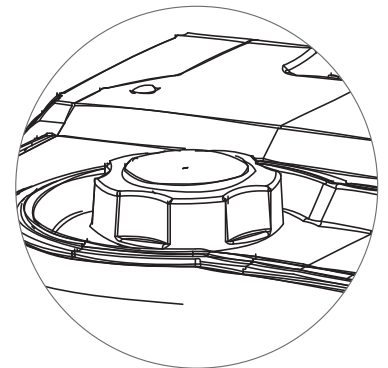

Turn cap counterclockwise to remove.



Do not overfill the fuel tank.
Provide space for fuel expansion.

ASSEMBLY

Connecting the Battery

- Unclip the right side panel
- Put the battery into the square hole beside the recoil handle
- Slide the battery into the until it clicks into place.

NOTE: The electric start generator is equipped with a battery charging feature. Once the engine is running, a small charge is supplied to the battery via the battery tray and will recharge the battery.

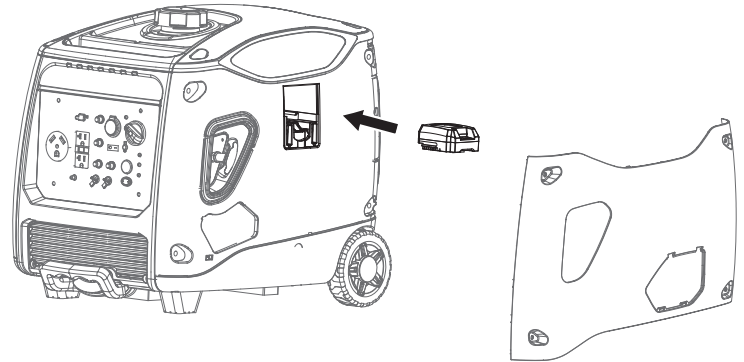

Checking/Adding Engine Oil

- Place generator on a firm level surface.
- Unclip and remove the oil service panel to access the oil fill/dipstick.

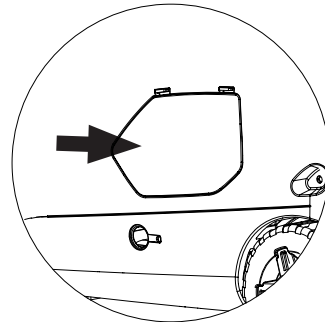

- Remove the crankcase dipstick.

Recommended Oil: SAE 10W-30
Oil Capacity: 0.6L (20.2oz)

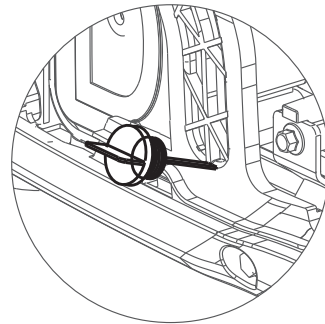

- Insert a funnel into the crankcase dipstick hole and carefully add the specified amount of engine oil (SAE 10W-30) to empty reservoir until or oil reaches the outer edge of the oil fill hole (crankcase dipstick hole).
- Be sure to replace dipstick and tighten securely before attempting to start the engine.
- To check oil, set generator on a firm level surface, unscrew and remove dipstick, wipe dipstick clean, then reinsert dipstick without re-threading.



CAUTION!

Generator has been shipped without engine oil. You must add engine oil before operating this generator. Always check oil level before each operation.

OPERATION

Standard Atmospheric Conditions

Ambient Temperature: 77°F (25°C)

Barometric Pressure: 750 mmhg

Relative Humidity: 30%

Generator output will vary due to changes in temperature, altitude, and humidity. If the temperature, altitude, and humidity are higher than standard atmospheric conditions, the generator's output will be reduced.

How to Start Engine - Manual Start

- Place generator on a level surface. All electrical loads **MUST** be disconnected from generator.
- Battery ON/OFF Switch to "ON" position
- Turn the FUEL VALVE Knob to "ON"
- Pull the recoil starter grip slowly until resistance is felt; retract, then pull rapidly.

Manual Start

Push Button Start & Remote Start

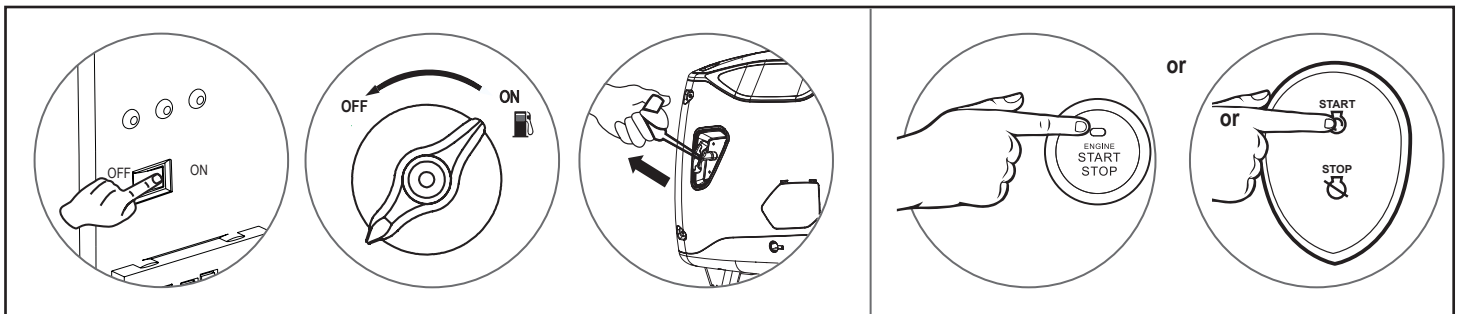

How to Start Engine - Push Button Start & Remote Start

- Place generator on a level surface. All electrical loads **MUST** be disconnected from generator.
- Battery ON/OFF Switch to "ON" position
- Turn the FUEL VALVE Knob to "ON"
- Push the One Push Start Button until generator starts. Remote Start: push the control Start button until the engine starts. *(make sure battery is connected)*



Pull cord recoils rapidly and can pull arm towards engine faster than you can let go could result in injury.

- Pull starter cord slowly until resistance is felt; retract, then pull rapidly.

Note: To start the generator with the Economy switch in the "ON" position

- Disconnect all electrical loads from generator.
- If ambient temperature is below 32°F (0°C) allow about 3 minutes for the engine to warm up.
- With the Economy switch in "ON" position, the unit returns to normal operation after the above warm up time.
- Economy switch must be in the "OFF" position when using electrical devices that require a large starting current, such as an air compressor.

OPERATION

How to Stop Engine

- Turn the FUEL VALVE Knob to the “OFF” position.
- Disconnect any electrical devices. All loads **MUST** be disconnected from the generator. Never start or stop the engine with electrical devices plugged in to the receptacles.
- Push the One Push Start Button
- For Remote Stop push the Stop button
- Turn Battery ON/OFF Switch to the “OFF” position.

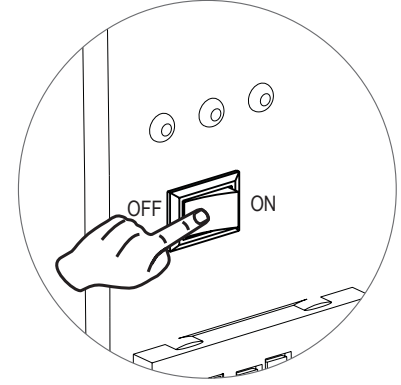
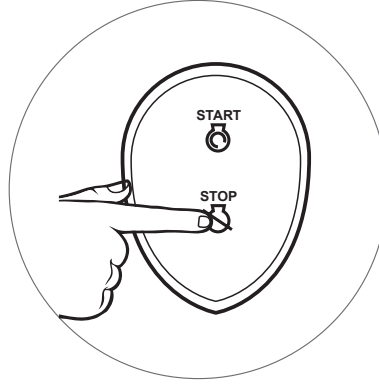
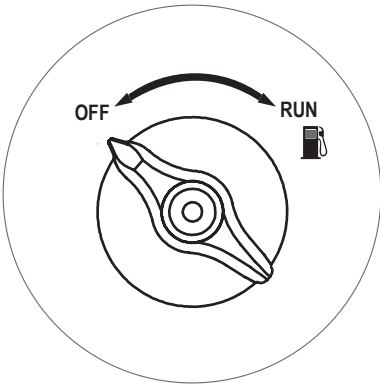

WARNING!

Never start or stop engine with electrical devices plugged in to the receptacles. Failure to heed this warning could damage the generator and/or connected electrical devices.

- Always start the engine and let it stabilize before connecting any electrical devices.
- Disconnect all electrical devices before stopping the engine.

How to Attach Electrical Devices

- Before starting generator, make sure the generator is adequately grounded, per application (see page 10 for instructions).
- Make sure the attached load is within the generator rated output and the receptacle’s rated current.
- Make sure all electrical cords and receptacles are in good condition.
- Make sure all electrical devices are turned “OFF” before plugging them into the generator.
- Start engine.
- If the attached electrical load is small, move the Economy switch to the “ON” position. For a larger electrical load, or if attaching multiple electrical devices, move the Economy switch to the “OFF” position.
- Make sure the green AC pilot indicator light is on.
- When engine has stabilized, plug in and switch on first load. It is strongly recommended to plug in devices with the largest electrical demand first and the smallest electrical demand last to help prevent overloading the generator.
- Allow generator output to stabilize (engine and attached electrical devices run evenly) before plugging in the next load.

OPERATION

Charging a 12 Volt Battery

This generator can be used to charge a 12 volt automotive or storage battery by taking the following steps:

Inspect fluid level of the battery cells (if applicable). Add ONLY distilled water to any cell where fluid level is low. Never add tap water.

1. Use a wire brush to clean battery terminals if corroded.
2. Securely connect the red cable clamp to the positive (+) battery terminal.
3. Securely connect the black cable clamp to the negative (-) battery terminal.
4. Turn the Economy switch to the "OFF" position when charging battery.
5. Battery is considered fully charged when the voltage is at or above 12.7vdc, when measured by a volt meter.

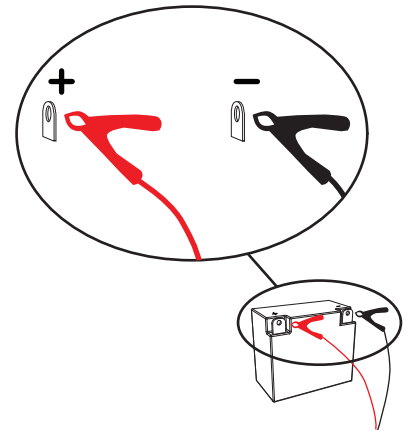

Note: It is strongly recommended to check battery voltage level at least once per hour with a volt meter to prevent overcharging and to test the battery's condition.



WARNING!



Battery electrolyte is poisonous and dangerous.

- Do not disconnect battery clamps while charging. Batteries produce and vent explosive gasses. Disconnecting the battery clamps while charging could cause a spark and lead to a fire.
- Do not charge any battery in an enclosed area.
- Never smoke while charging the battery or operating or fueling this generator.
- Battery electrolyte contains sulfuric acid. Avoid contact with skin, eyes, and clothing. Always wear eye protection when charging battery.
- If battery acid contacts skin, flush with water immediately. If it contacts eyes, flush with water for 15 minutes and get immediate medical attention. For internal ingestion, drink large quantities of water or milk, followed by milk of magnesia, beaten egg, or vegetable oil. Contact a medical physician immediately.

OPERATION

AC Parallel Operation

It is possible to connect two PG4500iSR generators to each other, using a parallel cable kit, to increase available power output

- You may connect PARALLEL OPERATION CABLES to two PG4500iSR generators according to the instructions provided with parallel cable kit.
- Make sure the Economy switch is in the same position on both generators.
- All electrical devices should be turned “OFF” and disconnected from generators prior to starting generator engines.
- Start generator engines. Make sure the green AC Pilot indicator light comes on for each generator.
- When engines have stabilized, plug in electrical devices to AC receptacle and turn on first load.
- Allow generator output to stabilize (the first electrical device to an AC receptacle on the parallel cable kit.) before plugging in the next electrical load.

Limit start-up time to 3 seconds for load requiring maximum output. For continuous operation, do not exceed the rated output.

Note: It is strongly recommended to plug in devices with the largest electrical demand output first and the smallest electrical demand last to help prevent overloading the generator.

Note: Most electrical devices require power beyond its rated wattage to start. This additional power is referred to as surge watts and motor-based start-up loads usually last between 2-3 seconds. When an electrical device is started, the red overload indicator may come on. This is normal. If the light stays on disconnect all electrical devices and stop the engine.



WARNING!

Only connect electrical devices to the generator that are in good working order and do not exceed the rated power supply of the generators in parallel or the desired receptacle.

- A faulty appliance or power cord can create an electric shock. Do not use electrical devices that have a damaged cord or plug.
- If an appliance begins to operate abnormally, becomes sluggish, or stalls, switch off and disconnect appliance immediately. The appliance may have a fault or its rated load requirements exceeds the capacity of the generator.
- To avoid damage to generator or electrical device, do not connect a load to the generator if its electrical rating exceeds that of the receptacle.



WARNING!

Never connect generators that are different models.

- Only connect this generator to another PG4500iSR generator.
- Only use a PULSAR approved parallel operation cable kit to connect generators.
- The parallel operation kit must be removed if operating only one generator.
- Never disconnect or remove and parallel operation kit while generator(s) are still running.

OPERATION

Don't Overload Generator

Make sure that your generator can supply enough rated watts and surge watts for all electrical loads connected to the generator. Surge watts refer to the power a generator must supply to start an electrical device. This power surge for starting a device usually lasts between 2-3 seconds but this additional output must be considered when selecting the electrical devices you plan to attach to the generator.

Operating voltage and frequency requirement of all electrical equipment should be verified prior to plugging them into this generator. Damage may result if the equipment is not designed to operate within a +/- 10% voltage variation, and +/- 3 Hz frequency deviation from the generator name plate ratings.

Wattage Reference Guide

(Wattages listed are approximations. Check electrical devices for actual wattage)

Essentials	Rated Watts	Surge Watts
75W Light Bulbs	75 each	75 each
18 CU Ft Refrigerator / Freezer	800	2200
Furnace Fan (1/3 HP)	800	2350
Sump Pump (1/3 HP)	1000	2000
Water Pump (1/3 HP)	1000	3000
Heating/Cooling		
Dehumidifier	650	800
Table Fan	200	300
Window AC (10k BTU)	1200	3600
Central Air (4 ton)	1500	6000
Electric Blanket	400	400
Space Heater	1800	1800
Kitchen		
Blender	300	900
Toaster (2 slice)	1000	1000
Coffee Maker	1500	1500
Electric Range (1 element)	1500	1500
Dishwasher	1500	2000
Electric Oven	3500	3500
Electric Water Heater	4000	4000
Laundry Room		
Iron	1200	1200
Washing Machine	1150	2400
Gas Clothes Dryer	700	1500
Electric Clothes Dryer	5400	6750

Bathroom	Rated Watts	Surge Watts
Hair Dryer	1250	1250
Curling Iron	1000	1000
Family Room		
X-Box or Play Station	40	40
AM/FM Radio	10	10
VCR	100	100
TV or Monitor (40")	200	200
Home Office		
Fax Machine	65	65
Personal Computer (17" Monitor)	800	800
Laser Printer	250	950
Copy Machine	700	800
Power Tools		
1000W Quartz Halogen Work Light	1000	1000
Airless Sprayer (1/3 HP)	600	800
Reciprocating Saw	750	950
Circular Saw (7 1/4")	1400	2300
Miter Saw (10")	800	1200
Table/Radial Arm Saw	1000	2000
Electric Drill (1/2 HP, 5.4 Amps)	600	900
Hammer Drill	700	1000
Air Compressor	1600	4500
Other		
Home Security System	500	500
Garage Door Opener (1/3 HP)	750	750



WARNING!

Never exceed generator's wattage/ampere capacity. This could damage the generator and/or connected electrical devices.

- Verify operating voltage and frequency requirements of all electrical devices prior to plugging in to the generator.

MAINTENANCE

Regular maintenance will extend the life of this generator and improve its performance. The warranty does not cover items that result from operator negligence, misuse, or abuse. To receive full value from the warranty, operator must use the generator as instructed in this manual, including proper storage.



WARNING!

Before inspecting or servicing this machine, make sure the engine is off and no parts are moving. Disconnect the spark plug wire and move it away from the spark plug.



CAUTION!

If you are unsure of how to perform a maintenance task, have the unit serviced by an authorized PULSAR dealer.



CAUTION!

Only use specified PULSAR replacement parts.

Pre-Operation Steps

Before starting the engine, perform the following pre-operation steps:

- Check the engine oil and the fuel tank level.
- Make sure the air filter is clean.
- Remove any debris that has collected on the generator and around the muffler and controls. Use a vacuum cleaner to pick up loose debris. If dirt is caked on, use a soft bristle brush.
- Inspect the work area for hazards.

After Each Use

- Turn the FUEL VALVE Knob to “OFF”
- Switch OFF the engine
- Switch Off the battery
- Wait for the generator to become cool to the touch
- Store unit in a clean and dry area.

Maintenance Schedule

After First 5 Hours	Change Oil
After 8 Hours or Daily	Clean Debris from Generator and Air Filter area
	Check Engine Oil Level
Annually (25 hr Use)	Check and Clean Air Cleaner
	Change Engine Oil after the first 25 hours, again at 50 hours; then every 100 hours thereafter.
	Inspect Muffler and Spark Arrester
Annually (100 hr Use)	Service Spark Plug (Replace with NGK BP6ES, Champion N9YC or equivalent)
	Inspect Fuel Valve and Fuel Lines for leaks or damage
	Inspect Muffler and Spark Arrester
	Check and Clean Air Cleaner Assembly, Replace Air Filter
	Clean Cooling System Cylinder Head Fins and Flywheel Fan

MAINTENANCE

Checking Spark Plug

- Remove the Engine Service Panel to gain access to the spark plug.
- Disconnect the spark plug wire from the spark plug.
- Before removing the spark plug, clean the area around its base to prevent debris from entering the engine.
- Insert a 19mm, 6-point, deep-well spark plug socket wrench through the opening on the outside of the cover. Turn the wrench counter clockwise to loosen and remove spark plug.
- Check for discoloration and clean carbon deposits from the electrode with a wire brush.
- Check the electrode gap and slowly adjust to 0.6 - 0.7mm (0.024-0.028 in) if necessary.
- Reinstall spark plug and tighten to 20.0Nm (15 ft-lb) of torque.
- If spark plug is worn, replace only with an equivalent type. Spark plug should be replaced annually regardless of apparent condition.
- Reconnect spark plug wire, firmly, until it clicks into place.

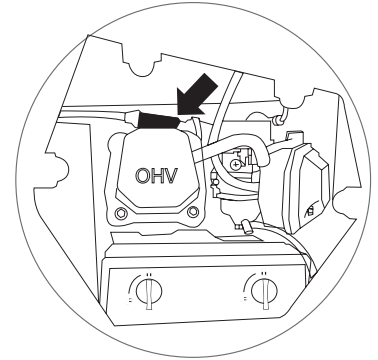

Pull off Spark Plug Cover

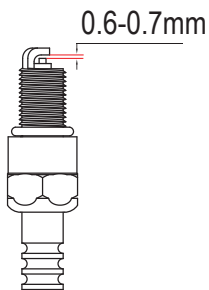

Standard Spark Plug: F7TC/F7RTC

Spark Plug Gap: 0.6 - 0.7mm (0.024-0.028 in)

Spark Plug Torque: 20.0Nm (15 ft-lb)

Carburetor Adjustment

The carburetor is low emission and is equipped with a non-adjustable idle mixture valve. If adjustment is needed contact an authorized PULSAR Products dealer.

Oil Recommendations

- Do not use special additives.
- Outdoor temperatures determine the proper oil viscosity for the engine. Use the chart to select the best viscosity for the outdoor temperature range expected.

Note: * Below 40 °F (4 °C) the use of SAE 30 will result in hard starting.

** Above 80 °F (27 °C) the use of 10W-30 may cause increased oil consumption.

Check oil level more frequently

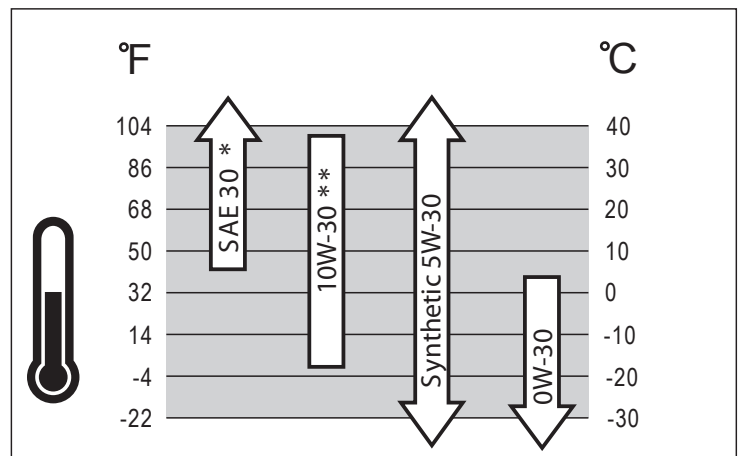

MAINTENANCE

Changing Oil

- Run the generator until the engine is warm, then shut OFF.
- Place generator on a firm and level surface, raised on blocks for easier access.
- Remove the crankcase dipstick.
- Place an oil pan underneath the oil drain hole to collect used oil.
- Remove the oil drain plug and allow oil to drain completely.
- Reinstall oil drain plug, tighten securely.
- Carefully add SAE 30 or 10W-30 engine oil to empty reservoir until the oil reaches the threads of the oil fill hole (Crankcase Dipstick hole).
- Replace crankcase dipstick.

Oil Recommendations

- Do not use special additives.
- Operating temperatures can affect proper oil viscosity for the engine.
- Use the chart (pg 19) to select the best viscosity for the operating temperature range expected.

Recommended Engine Oil: SAE 10W-30

Recommended Engine Oil Grade: API Service type SE or higher engine oil.

Engine Oil Quantity: 0.6L (20.2 oz)



CAUTION!

Do not tilt generator when adding oil. This could result in overfilling or under filling which could damage the engine.



CAUTION!

Ensure no foreign matter enters the crankcase

High Altitude Operation

At high altitude, the standard carburetor air/fuel mixture will be too rich. Performance will decrease, and fuel consumption will increase. A very rich mixture will also foul the spark plug and cause hard starting. Operation at an altitude that differs from that at which this engine was certified, for extended periods of time, may increase emissions. High altitude performance can be improved by specific modifications to the carburetor. If you always operate your generator at altitudes above 5,000 feet (1,500 meters), have your dealer perform this carburetor modification. This engine, when operated at high altitude with the carburetor modifications for high altitude use, will meet each emission standard throughout its useful life. Even with carburetor modification, engine horsepower will decrease about 3.5% for each 1,000-foot (300-meter) increase in altitude. The effect of altitude on engine power will be greater than this if no carburetor modification is made.

MAINTENANCE

Air Filter

A dirty air filter will reduce the life span of the engine, make it difficult to start the engine, and reduce the unit's performance. Replace with new Air Filter annually.

- To clean, remove the screws then remove left outer casing
- Turn the spring latches to lift then open air filter cover.
- Remove the pleated paper filter
- Blow the dust away with a compressed air
- Reinsert the pleated paper filter into the air filter case.

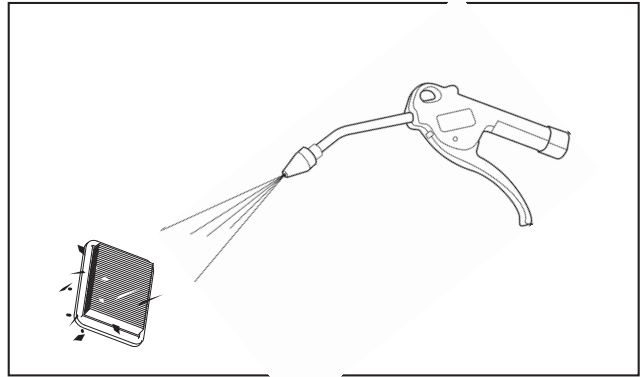
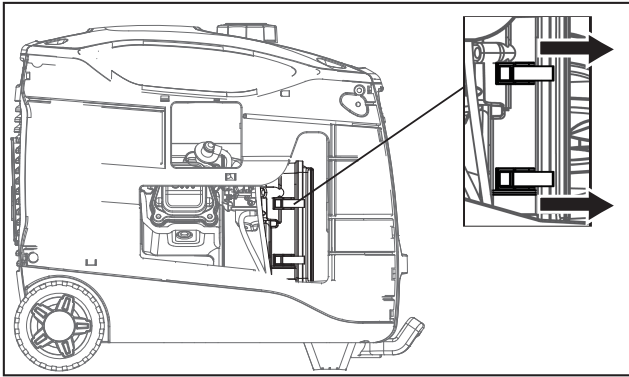

CAUTION!

Do not run the generator without reinstalling the foam element or excessive piston and cylinder wear may result, or excessive engine wear may result.

Checking Muffler and Spark Arrester

- Inspect muffler for cracks, corrosion, or other damage.
- Remove screws, then remove the muffler cover as shown.
- Remove the cover, then remove muffler cap, muffler screen, and spark arrester.
- Check the muffler screen and spark arrester for carbon deposits. Remove carbon deposits with a wire brush.
- Check the muffler screen and spark arrester for damage. If damaged replace with PULSAR replacement parts specifically designed for this unit.
- Install the spark arrester.
- Align the spark arrester insert with the hole in the muffler pipe.
- Install the muffler screen and rear grille.
- Install the outer casing and tighten the screws.

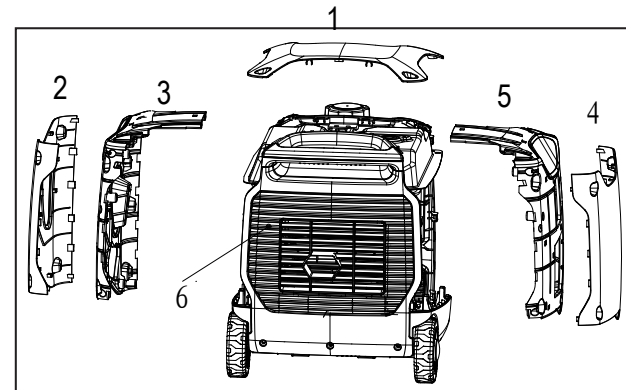

WARNING!



Avoid contacting hot areas of this generator.

- Use caution around the muffler, cylinder, and other engine parts as they can be extremely hot.
- Allow hot components to cool before touching.

MAINTENANCE

Fuel Tank Filter

- To clean, remove fuel cap and filter.
- Clean filter in a bucket of hot water with dish detergent.
- Dry the filter the filter with a clean rag.
- Install filter.
- Install fuel cap.

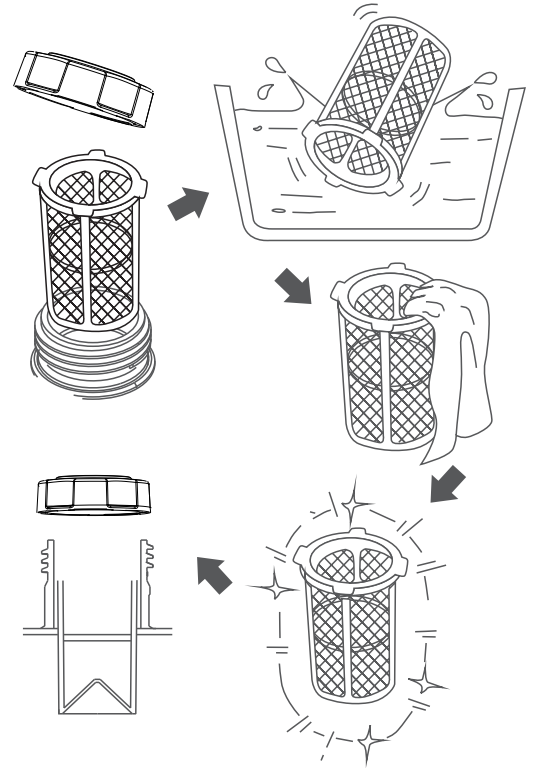

Storage and Transportation of the Generator:

When transporting the generator, turn fuel valve knob to the OFF position. Keep the generator on level ground to prevent fuel spillage. Fuel vapor or spilled fuel may explode or ignite.

- Remove any debris that has collected on the generator and around the muffler and control panel. Use a brush or vacuum to remove loose dirt.
- Inspect air cooling slots; remove any debris if obstructed.
- For short-term storage, start the generator once every 7 days.
- For intermediate term storage from 3-6 months, add fuel stabilizer to prevent stale fuel from causing acid and gum deposits in the fuel system and carburetor.
- For long-term storage, drain the fuel.
- Store a sheltered location such as a garage or outdoor storage shed where temperatures do not fall below freezing.
- The generator must be Shipped, Operated and Stored in the upright position.

MAINTENANCE



WARNING!

Contact with a hot engine or exhaust system can cause serious burns or fires. Let the engine cool before transporting or storing the generator.



CAUTION!

Take care not to drop or strike the generator when transporting. Do not place heavy objects on the generator.

Engine Long Term Storage:

- Remove the spark plug and pour about 1 teaspoon of 10W30 engine oil into the spark plug hole. Reinstall the spark plug. Turn fuel valve knob to the OFF position pull the recoil starter cord several times to coat the cylinder walls with oil.
- Slowly pull the recoil starter cord until you feel the engine build compression (when you feel resistance). Leave the engine in this state as this will prevent corrosion on the cylinder walls when stored for a long period of time.

How to Drain Fuel

- Turn OFF the engine, move the battery switch to OFF, turn the fuel valve to OPEN, remove the fuel cap and the debris screen underneath the fuel cap.
- Empty the fuel tank using a siphon and an approved gasoline container.
- Position a container under the carburetor drain tube. Loosen the drain valve screw.
- Allow fuel to completely drain and re-tighten the drain valve screw.
- Turn the fuel valve to CLOSED and replace the fuel cap.

Note: the drain tube is just used for drain fuel.

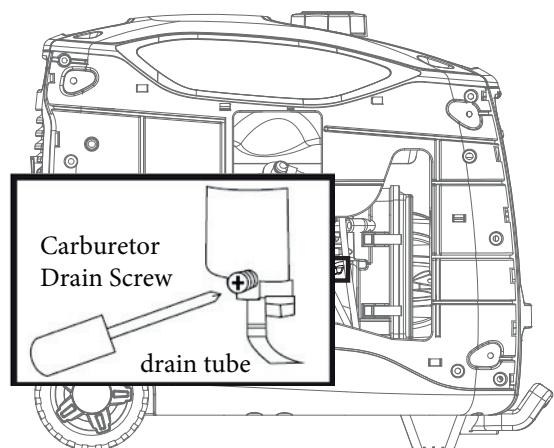
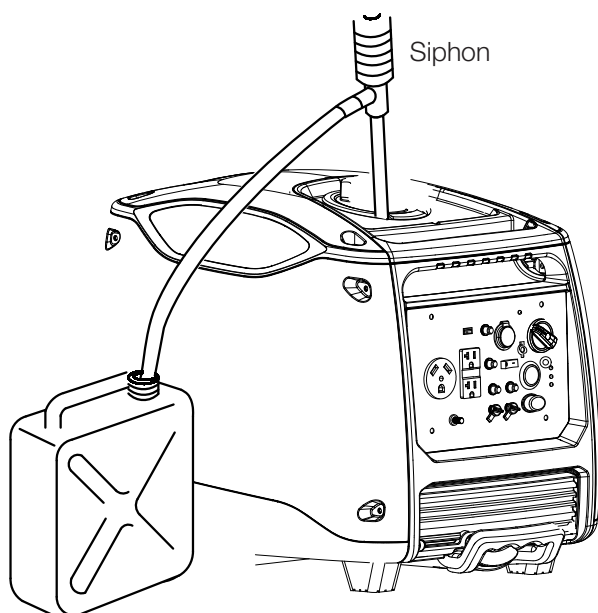

TROUBLESHOOTING

Problem	Cause	Solution
Engine is running, but AC output is not available	<ol style="list-style-type: none"> 1. Open circuit breaker 2. Poor connection 3. Defective cord set 4. Connected device is faulty 5. Fault in generator 	<ol style="list-style-type: none"> 1. Reset circuit breaker 2. Check and repair 3. Check and repair 4. Connect a device that is working properly 5. Contact service department
Engine runs well without load but bogs down when loads are connected	<ol style="list-style-type: none"> 1. Short circuit in connected device 2. Generator is overloaded 3. Clogged fuel filter 4. Engine speed is too slow 5. Short circuit in generator 	<ol style="list-style-type: none"> 1. Disconnect device 2. See pg 17 "Don't overload generator" 3. Contact service to replace fuel filter 4. Contact service department 5. Contact service department
Engine will not start, shuts down during operation, or starts and runs rough.	<ol style="list-style-type: none"> 1. ON/OFF switch set to "OFF" 2. Dirty Air filter 3. Clogged fuel filter 4. Stale fuel 5. Spark plug wire disconnected from spark plug 6. Bad spark plug 7. Water in fuel 8. Fuel valve knob on "OFF" position Low oil level Rich fuel mixture 10. Intake valve stuck open or close 11. Loss of engine compression 12. Engine has flooded 	<ol style="list-style-type: none"> 1. Turn switch to "ON" 2. Replace Air filter 3. Clean or replace fuel filter 4. Replace fuel 5. Reconnect spark plug wire 6. Replace spark plug 7. Drain fuel tank and replace fuel 8. Turn fuel valve to "ON" position FIRST place the generator on a level surface; THEN add oil 9. Contact service department 10. Contact service department 11. Contact service department 12. Wait 5 minutes and crank engine
Engine lacks power	<ol style="list-style-type: none"> 1. Generator is overloaded 2. Clogged in-line filter 3. Dirty air filter 4. Engine needs servicing 	<ol style="list-style-type: none"> 1. See pg. 17 "Don't overload generator" 2. Contact service to replace in-line filter 3. Replace Air filter 4. Contact service department
Engine "hunts" or falters	<ol style="list-style-type: none"> 1. Clogged in-line filter 2. Carburetor is running too rich or too lean 	<ol style="list-style-type: none"> 1. Contact service to replace in-line filter 2. Contact service department

WIRING DIAGRAM

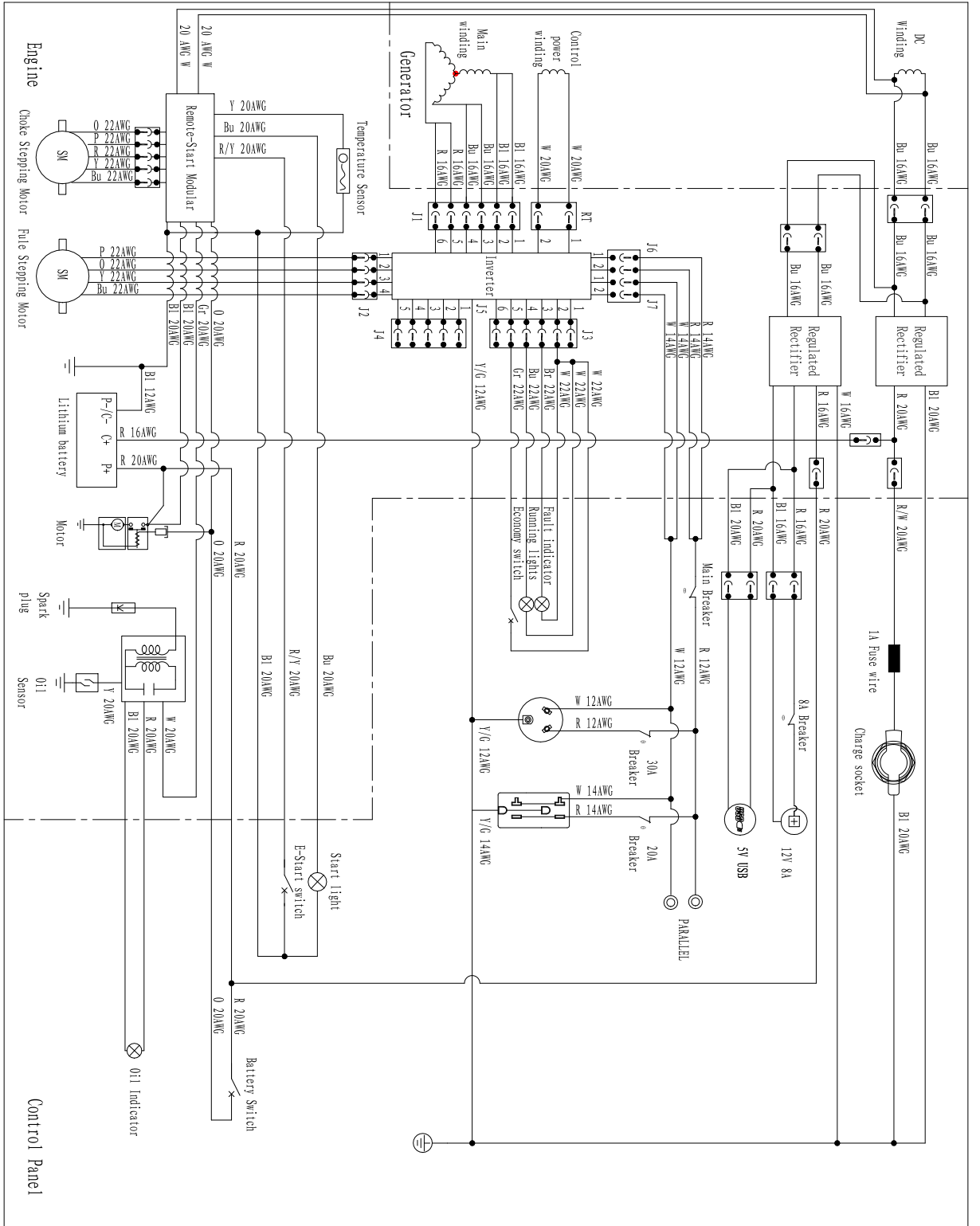

Bl	Black	Br	Brown	Y/G	Yellow green
R	Red	Br/R	Brown/red	R/Y	Red yellow
Bu	Blue	Gr	Gray	0	Orange
W	White	P	Pink		
Y	Yellow	Bl/W	Black/white		