

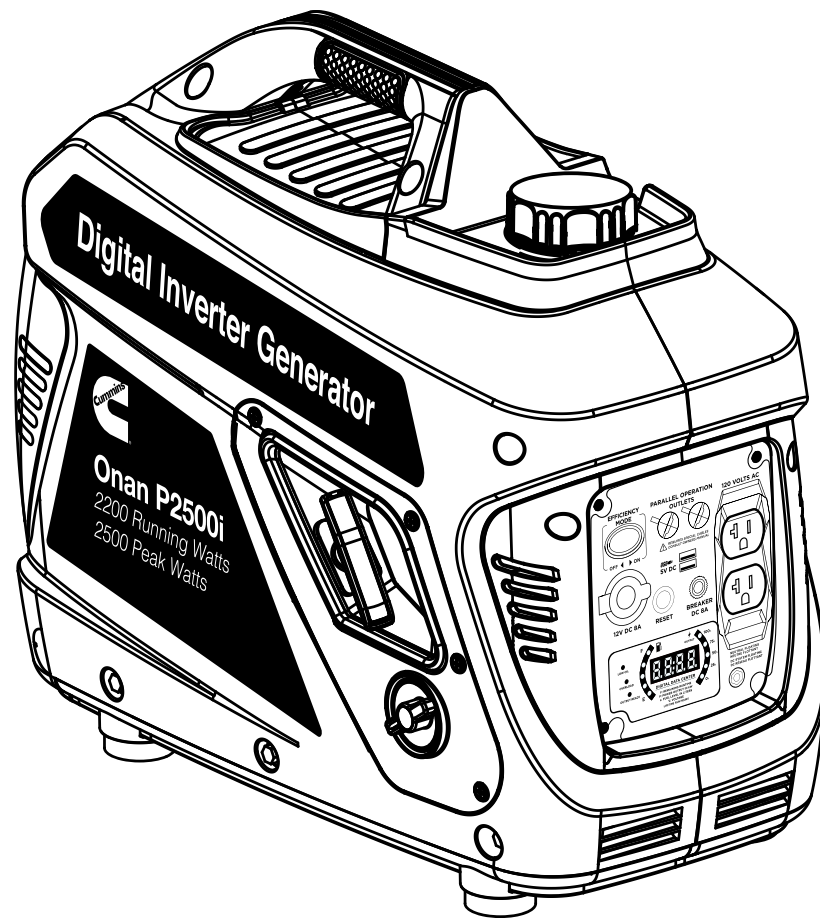

# Operator Manual

## Onan P2500i Inverter





**⚠ WARNING**

Operating, servicing and maintaining this equipment can expose you to chemicals including engine exhaust, carbon monoxide, phthalates, and lead, which are known to the State of California to cause cancer and birth defects or other reproductive harm. To minimize exposure, avoid breathing exhaust, do not idle the engine except as necessary, service your equipment in a well-ventilated area and wear gloves or wash your hands frequently when servicing your equipment. For more information go to [www.P65Warnings.ca.gov](http://www.P65Warnings.ca.gov).

**DISCLAIMERS:**

All information, illustrations and specifications in this manual are based on the latest information available at the time of publishing. The illustrations used in this manual are intended as representative reference views only. Moreover, because of our continuous product improvement policy, we may modify information, illustrations and/or specifications to explain and/or exemplify a product, service or maintenance improvement. We reserve the right to make any change at any time without notice. Some images may vary depending upon which model is shown.

**ALL RIGHTS RESERVED:**

No part of this publication may be reproduced or used in any form by any means – graphic, electronic or mechanical, including photocopying, recording, taping or information storage and retrieval systems – without the written permission of Cummins Inc.

**⚠ DANGER**

This manual contains important instructions for operating this inverter. For your safety and the safety of others, be sure to read this manual thoroughly before operating the inverter. Failure to properly follow all instructions and precautions can cause you and others to be seriously hurt or killed.

## TECHNICAL SPECIFICATIONS

Model Number	Running Watts	Peak Watts	Fuel Tank Size (L/G)	Rated Speed (RPM)	Ignition Type	Spark plug	Engine Disp (cc)	Stroke X Bore	Oil Capacity (L)	Oil Type	THD
P2500i	2200	2500	3.8/1.0	5500	CDI	E6RTC	98	52X46	0.35	10W30	<5%



**1-800-CUMMINS**  
(1-800-286-6467)

**FOR YOUR RECORDS:**

Date of Purchase:	
Inverter Model Number:	
Purchased from Store/Dealer:	
Inverter Serial Number:	

**IMPORTANT: KEEP YOUR PURCHASE RECEIPT TO ENSURE TROUBLE-FREE WARRANTY COVERAGE.**

**PRODUCT REGISTRATION**

To ensure trouble-free warranty coverage, it is important you register your Cummins inverter.

You can register your inverter by either:

1. Filling in the product registration form below and mailing to:

**Product Registration**

Cummins Inc  
 301 E. Market St.  
 Indianapolis, IN 46204

2. Registering your product Online at [www.cummins.com/support/product-registration](http://www.cummins.com/support/product-registration)  
 To register your inverter you will need to locate the following information:



**CUMMINS PRODUCT REGISTRATION FORM**

**PERSONAL INFORMATION**

**INVERTER INFORMATION**

First Name: \_\_\_\_\_ Model Number: \_\_\_\_\_

Last Name: \_\_\_\_\_ Serial Number: \_\_\_\_\_

Street Address: \_\_\_\_\_ Date Purchased: \_\_\_\_\_

Street Address: \_\_\_\_\_ Purchased From: \_\_\_\_\_

City, State, ZIP: \_\_\_\_\_

Country: \_\_\_\_\_

Phone Number: \_\_\_\_\_

E-Mail: \_\_\_\_\_

## TABLE OF CONTENTS

<b>TECHNICAL SPECIFICATIONS</b> .....	2	<b>MAINTENANCE</b> .....	17
<b>PRODUCT REGISTRATION</b> .....	3	Maintenance Schedule .....	17
For Your Records: .....	3	Engine Oil Maintenance .....	18
Product Registration .....	3	Checking Engine Oil .....	18
Product Registration Form .....	3	Adding Engine Oil .....	18
<b>SAFETY</b> .....	5	Changing Engine Oil .....	19
Safety Definitions .....	5	Air Filter Maintenance .....	19
Safety Symbol Definitions .....	5	Cleaning the Air Filter .....	19
General Safety Rules .....	6	Draining the Float Bowl .....	20
Safety Labels and Decals .....	7	Spark Plug Maintenance .....	21
<b>UNPACKING</b> .....	7	Cleaning the Spark Arrestor .....	22
<b>FEATURES</b> .....	8	Checking and Adjusting Valve Lash .....	22
Basic Inverter Features .....	8	Cleaning the Inverter .....	23
Control Panel Features .....	9	Storage .....	23
LED Digital Data Display .....	10	<b>TROUBLESHOOTING</b> .....	24
<b>OPERATION</b> .....	11	<b>EXPLODED AND ENGINE VIEWS</b> .....	25
Before Starting the Inverter .....	11	P2500i Exploded View .....	25
Location Selection .....	11	P2500i Exploded View Part No .....	26
Weather .....	11	P2500i Engine View .....	27
Dry Surface .....	11	P2500i Engine View Part No .....	28
No Connected Loads .....	11	P2500i Schematic .....	29
Grounding the Inverter .....	11		
Powercord .....	12		
Initial Oil Fill .....	13		
Adding/Checking Engine Fluids and Fuel .....	14		
Checking and/or Adding Engine Oil .....	14		
Adding Gasoline to the Fuel Tank .....	14		
Starting P2500i .....	15		
Stopping the Inverter .....	16		
Using Efficiency Mode .....	16		
Resetting the Reset Breaker .....	16		

### SAFETY DEFINITIONS

The words DANGER, WARNING, CAUTION and NOTICE are used throughout this manual to highlight important information. Be certain that the meanings of these alerts are known to all who work on or near the equipment.



This safety alert symbol appears with most safety statements. It means attention, become alert, your safety is involved! Please read and abide by the message that follows the safety alerts symbol.

**⚠ DANGER**

Indicates a hazardous situation which, if not avoided, *will* result in death or serious injury.

**⚠ WARNING**

Indicates a hazardous situation which, if not avoided, *could* result in death or serious injury.

**⚠ CAUTION**

Indicates a hazardous situation which, if not avoided, *could* result in minor or moderate injury.

**NOTICE**

Indicates a situation which can cause damage to the inverter, personal property and/or the environment, or cause the equipment to operate improperly.

**NOTE:** Indicates a procedure, practice or condition that should be followed in order for the inverter to function in the manner intended.

### SAFETY SYMBOL DEFINITIONS

Symbol	Description
	Safety Alert Symbol
	Asphyxiation Hazard
	Burn Hazard
	Burst/Pressure Hazard
	Don't leave tools in the area
	Electrical Shock Hazard
	Explosion Hazard
	Fire Hazard
	Lifting Hazard
	Pinch-Point Hazard
	Read Manufacturer's Instructions
	Read Safety Messages Before Proceeding
	Wear Personal Protective Equipment (PPE)

## GENERAL SAFETY RULES

### ⚠ DANGER



Never use the inverter in a location that is wet or damp. Never expose the inverter to rain, snow, water spray or standing water while in use. Protect the inverter from all hazardous weather conditions. Moisture or ice can cause a short circuit or other malfunction in the electrical circuit.



Never operate the inverter in an enclosed area. Engine exhaust contains carbon monoxide. Only operate the inverter outside and away from windows, doors and vents.

### ⚠ WARNING



Voltage produced by the inverter could result in death or serious injury.

- Never operate the inverter in rain or a flood plain unless proper precautions are taken to avoid being subject to rain or a flood.
- Never use worn or damaged extension cords.
- Always have a licensed electrician connect the inverter to the utility circuit.
- Never touch an operating inverter if the inverter is wet or if you have wet hands.
- Never operate the inverter in highly conductive areas such as around metal decking or steel works.
- Always use grounded extension cords. Always use three-wire or double-insulated power tools.
- Never touch live terminals or bare wires while the inverter is operating.
- Be sure the inverter is properly grounded before operating.

### ⚠ WARNING



Gasoline and gasoline vapors are extremely flammable and explosive under certain conditions.

- Always refuel the inverter outdoors, in a well-ventilated area.
- Never remove the fuel cap with the engine running.
- Never refuel the inverter while the engine is running. Always turn engine off and allow the inverter to cool before refueling.
- Only fill fuel tank with gasoline.
- Keep sparks, open flames or other form of ignition (such as match, cigarette, static electric source) away when refueling.
- Never overfill the fuel tank. Leave room for fuel to expand. Overfilling the fuel tank can result in a sudden overflow of gasoline and result in spilled gasoline coming in contact with HOT surfaces. Spilled fuel can ignite. If fuel is spilled on the inverter, wipe up any spills immediately. Dispose of rag properly. Allow area of spilled fuel to dry before operating the inverter.
- Wear eye protection while refueling.
- Never use gasoline as a cleaning agent.
- Store any containers containing gasoline in a well-ventilated area, away from any combustibles or source of ignition.
- Check for fuel leaks after refueling. Never operate the engine if a fuel leak is discovered.

### ⚠ WARNING



Never operate the inverter if powered items overheat, electrical output drops, there is sparking, flames or smoke coming from the inverter, or if the receptacles are damaged.



Never use the inverter to power medical support equipment.



Always remove any tools or other service equipment used during maintenance from the inverter before operating.

### NOTICE

**Never modify the inverter.**

**Never operate the inverter if it vibrates at high levels, if engine speed changes greatly or if the engine misfires often.**

**Always disconnect tools or appliances from the inverter before starting.**

## SAFETY LABELS AND DECALS



**Model/Modelo** Onan P2500  
**Part No./Número de parte** A058U044  
**AC Voltage/Voltage** 120V  
**Power (Running)/Potencia (nominal)** 2200W  
**Power (Peak)/Potencia (pico)** 2500W  
**Current/Corriente** 18A  
**DC Voltage/Voltage** 12V  
**Current/Corriente** 8A  
**Frequency/Frecuencia** 60Hz  
**Phase/Fase** Single/Single  
**RPM/Tr** 5200  
**Power Factor/Factor de potencia** 1.0  
**Insul Class/Clase de aislamiento** F  
**Max Amb Temp/Temperatura máxima** 40°C (104°F)  
**Fuel/Combustible** Gasoline  
**Fuel Tank Size/Tamaño del tanque de combustible** 3.7L/1G  
**Oil: SAE 10W-30**   
**Oil Capacity/Capacidad de aceite** .37 QT/1.8 OZ/350 ML

**Read and understand operating instructions before starting.**  
*Lea y comprenda las instrucciones de operación antes de comenzar.*

**Provide proper ventilation! Do not operate in a confined area.**  
*Proporcione una ventilación adecuada! No opere en un área confinada.*

**Do not operate in wet conditions. Electrical shock may result and could be fatal. No opere en condiciones húmedas. (Puede producirse una descarga eléctrica y podría ser fatal.)**

**Cummins Inc.**  
 Columbus Indiana 47201 USA  
Designed in Columbus, Ohio USA/Made in China  
 Diseñado en Columbus, Ohio, E.E. UU./Hecho en China

**WARNING:** Cancer and reproductive harm -  
[www.P2500generator.com](http://www.P2500generator.com)  
 advertencias: Cáncer y problemas de reproducción - [www.P2500generator.com](http://www.P2500generator.com)  
 advertencias: Cáncer y problemas de reproducción - [www.P2500generator.com](http://www.P2500generator.com)

**Spark Plug/Bujía**  
 Use OEM spark plug only. Please refer to Owner's Manual for information on spark plug type, torque and installation.  
**Spark plug: Torch E8RTC**  
 Spark plug gap: .8 mm/.03 in

**WARNING:**  
 \* Use gasoline with a minimum octane rating of 87.  
 \* Do not direct exhaust fumes toward people, buildings or equipment.  
 \* Check and refill oil as required to ensure proper inverter performance.  
 \* When refueling, always stop the engine.  
 \* Immediately wipe up any spilled fuel.  
 \* Keep any flammable items away from this equipment.  
 \* Do not touch or contact outlets with wet hands.  
 \* Do not expose inverter directly to rain or snow.  
 \* Do not connect the AC output to any indoor wiring.  
 \* Clean spark arrestor every 50 hours to prevent engine damage.  
 \* When operating your inverter, do not erect any barriers or obstacles around the equipment or inhibit air or exhaust flow.

**DANGER**  
 Using a generator indoors **CAN KILL YOU IN MINUTES.**  
 Generator exhaust contains carbon monoxide. This is a poison you cannot see or smell.  
 Usar un generador en el interior **PUEDA MATARLE EN MINUTOS.** El escape del generador contiene monóxido de carbono. Este es un veneno que no puedes ver ni oler.

**NEVER** use inside a home or garage, **EVEN IF** doors and windows are open.

**NUNCA** lo use dentro de una casa o un garaje, **INCLUSO** si las puertas y ventanas están abiertas.

Only use **OUTSIDE** and far away from windows, doors, and vents.

Use solo **FUERA** y lejos de ventanas, puertas y ventiladores.

Have Questions?  
1-800-CUMMINS

FOR USE IN DRY WEATHER PROTECTED LOCATIONS ONLY.  
PARA USO EN LUGARES PROTEGIDOS CON TIEMPO SECO SOLAMENTE.

## UNPACKING

**⚠ CAUTION**

Always have assistance when lifting the inverter. The inverter is heavy; lifting it could cause bodily harm.

---

Avoid cutting on or near staples to prevent personal injury.

**Tools required** – box cutter or similar device.

1. Remove socket wrench, oil and funnel and save for later.
2. Carefully cut two sides of the carton to remove the inverter.

### WHAT COMES IN THE BOX

- Spark Plug Socket Wrench (1)
- Owner Manual (1)
- Quick Start Guide (1)
- Warranty Information (1)
- Funnel (1)
- .37 QT/.35 L Bottle of 10W-30 Oil (1)



## BASIC INVERTER FEATURES



- ① **Fuel Cap:** Vent-less cap must be secure before operating.
- ② **Control Panel:** Contains the reset breaker, outlets and warning lights.
- ③ **Recoil Handle:** Pull to start the engine.
- ④ **Engine Control Switch:** Sets the choke, turns the fuel on and off.
- ⑤ **Engine Service Panel:** Remove the panel to access the spark plug and engine for maintenance.
- ⑥ **Muffler and Spark Arrestor:** Avoid contact until the engine is cooled down. The spark arrestor prevents sparks from exiting the muffler. It must be removed for servicing.
- ⑦ **Engine Cooling Vents:** Helps move airflow in unit to regulate engine temperatures. **DO NOT BLOCK**
- ⑧ **Recoil Maintenance Panel:** Remove to perform maintenance on pull cord or engine control switch.

## CONTROL PANEL FEATURE

- ① **120-Volt, 20-Amp Duplex Outlet (NEMA 5-20R):** The outlet is capable of carrying a maximum of 20 amps.
- ② **USB Duplex:** 5V DC that come in 1 amps and 2.1 amps.
- ③ **Reset Breaker:** If the inverter is overloaded, the reset breaker will trip. The engine will continue to run, but there will be no output from the inverter. Unplug the devices and reduce the load. Push in the reset breaker to reset it.
- ④ **Efficiency Mode Switch:** When turned to the ON position, the engine will sense the load needed and run at a slower RPM to save fuel.
- ⑤ **Ground Terminal:** The ground terminal is used to externally ground the inverter.
- ⑥ **Parallel Ports:** For use with Cummins 30A Parallel Kit (sold separate) and another P2500i inverter (sold separate) to double power output. Ideal for use in RV applications.
- ⑦ **LED Data Center:** Indicates low oil, overload and output ready. Displays fuel level, power output, remaining run time, voltage. See more information on the next page.
- ⑧ **12V DC Outlet:** 12V DC that has 8A output.
- ⑨ **12V DC Breaker:** 8A breaker for 12V outlet.

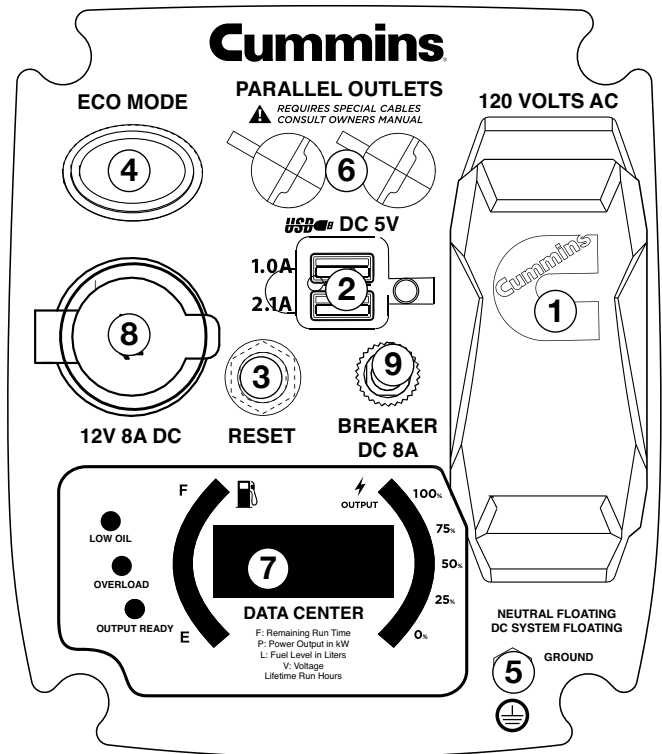

## LED Data Display

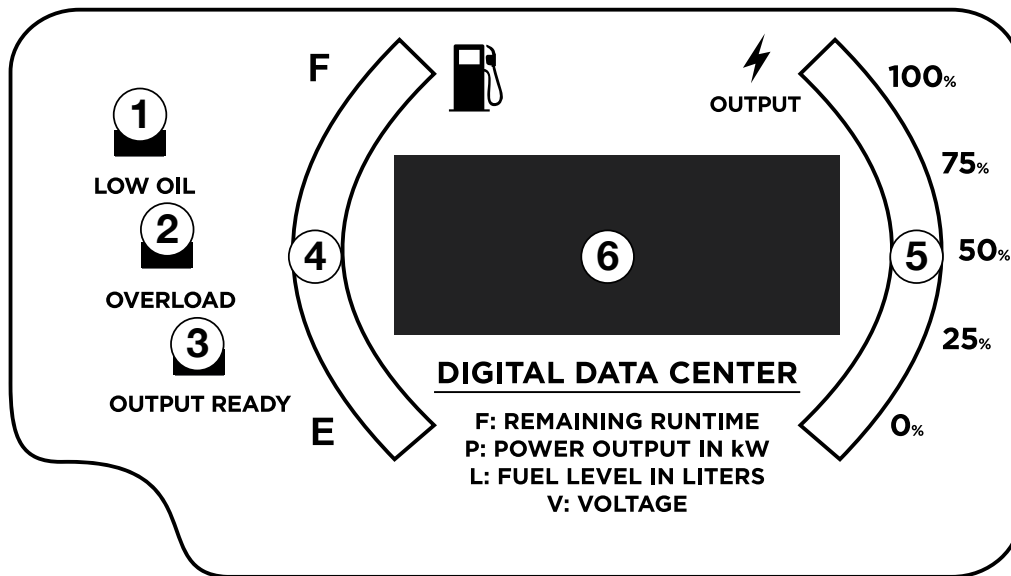

### ① LOW OIL INDICATOR

**Description:**

Lights up red when unit is low or out of oil. Engine will not run when indicator is lit.

**Recommended Action:**

When this light appears confirm engine is off, let the unit cool down, then add oil. Make sure to periodically check oil levels while filling to prevent overfilling.

### ② OVERLOAD INDICATOR

**Description:**

Red light flashes when the unit is close to overloading. If any more load is added when the light is flashing the electrical power will be cut to the receptacles and light will become a constant red.

**Recommended Action:**

While the engine is running, disconnect all appliances and hit the RESET breaker on the panel. Reduce the amount of appliances before plugging back in.

### ③ OUTPUT READY INDICATOR

**Description:**

The output ready indicator shows a green light when the inverter is operating normally and producing electrical power to the receptacles.

### ④ FUEL LEVEL INDICATOR

**Description:**

Displays estimated fuel level percentage. Four green lights indicate a full tank. One green light indicates the unit is almost out of fuel. For accurate fuel levels refer to “L” number in display.

### ⑤ ELECTRICAL POWER OUTPUT TO RECEPTACLES

**Description:**

Displays percentage of power output to the receptacles. A red light will display next to the “100%” if the unit is close to being overloaded. For accurate power output refer to the “P” number in display.

### ⑥ AUTOMATIC ROTATING DATA NUMBER DISPLAY

**Remaining Run Time (F):**

F 931

Displays time remaining with current fuel level and power output. Does not display lifetime hours.

**Power Output (P):**

P 121

Displays electrical power output to receptacles in kilowatts.

**Fuel level (L):**

L 28L

Displays current fuel level in liters.

**Voltage (V):**

V 122

Displays current voltage output of inverter.

## BEFORE STARTING THE INVERTER



**BEFORE STARTING THE INVERTER, REVIEW SAFETY SECTION STARTING ON PAGE 5.**

**Location Selection** – Before starting the inverter, avoid exhaust and location hazards by verifying:

- You have selected a location to operate the inverter that is outdoors and well ventilated.
- You have selected a location with a level and solid surface on which to place the inverter.
- You have selected a location that is at least 15 feet (4.5 m) away from any building, other equipment or combustible material.
- If the inverter is located close to a building, make sure it is not located near any windows, doors and/or vents.

<b>⚠ DANGER</b>	
Using a generator indoors <b>CAN KILL YOU IN MINUTES.</b> Generator exhaust contains carbon monoxide. This is a poison you cannot see or smell.	
 <b>NEVER</b> use inside a home or garage, <b>EVEN IF</b> doors and windows are open.	 Only use <b>OUTSIDE</b> and far away from windows, doors, and vents.
Avoid other generator hazards. <b>READ MANUAL BEFORE USE.</b>	

<b>⚠ WARNING</b>	
	Always operate the inverter on a level surface. Placing the inverter on non level surfaces can cause the inverter to tip over, causing fuel and oil to spill. Spilled fuel can ignite if it comes in contact with an ignition source such as a very hot surface.

<b>NOTICE</b>	
Only operate the inverter on a solid, level surface. Operating the inverter on a surface with loose material such as sand or grass clippings can cause debris to be ingested by the inverter that could:	
<ul style="list-style-type: none"> <li>• Block cooling vents</li> <li>• Block air intake system</li> </ul>	

**Weather** – Never operate your inverter outdoors during rain, snow or any combination of weather conditions that could lead to moisture collecting on, in or around the inverter.

**Dry Surface** – Always operate the inverter on a dry surface free of any moisture.

**No Connected Loads** – Make sure the inverter has no connected loads before starting it. To ensure there are no connected loads, unplug any electrical extension cords that are plugged into the control panel receptacles.

<b>NOTICE</b>
Starting the inverter with loads already applied to it could result in damage to any appliance being powered off the inverter during the brief start-up period.

### Grounding the Inverter

Consult with your local municipalities for your grounding codes.

<b>⚠ WARNING</b>	
	Be sure the inverter is properly connected to earth ground before operating.

### High Altitude Operation

Engine power is reduced the higher you operate above sea level. Output will be reduced approximately 3.5% for every 1000ft of increased altitude from sea level. This is a natural occurrence and cannot be adjusted by engine. Increased exhaust emissions can also result due to increased fuel mixture. Other issues include hard starting, increased fuel consumption and spark plug fouling.

## POWERCORD

### Using Extension Cords

Cummins Inc. assumes no responsibility for the content within this table. The use of this table is the responsibility of the user only. This table is intended for reference only. The results produced by using this table are not guaranteed to be correct or applicable in all situations as the type and construction of cords are highly variable. Always check with local regulations and a licensed electrician prior to installing or connecting an electrical appliance

**Extension Cord Wire Gauge Size**

AMPS	LENGTH OF EXTENSION CORD (ft)								
	10	20	30	40	50	60	80	100	120
5	20	18	16	14	12	12	10	10	8
10	18	16	14	12	12	10	10	8	8
15	16	14	12	12	10	10	8	8	6
20	14	12	12	10	10	8	8	6	6
25	12	12	10	10	8	8	6	6	6
30	12	10	10	8	8	6	6	6	6
35	10	10	8	8	6	6	6	6	6

## INITIAL OIL FILL



**BEFORE ADDING ENGINE OIL, REVIEW SAFETY SECTION STARTING ON PAGE 5.**

## NOTICE

Engine oil must be added when the inverter is on a flat, level surface, or an inaccurate reading may result. Do not overfill. If the engine is overfilled with oil, it can cause serious engine damage.

1. Turn the locking knob on the engine access panel and set aside (see Figure 1).

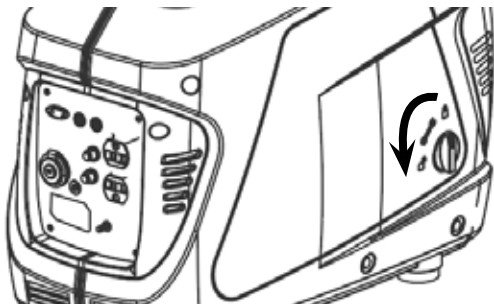

Figure 1: Engine Service Panel

2. Clean the area around the oil fill/drain plug and remove plug (See Figure 2).

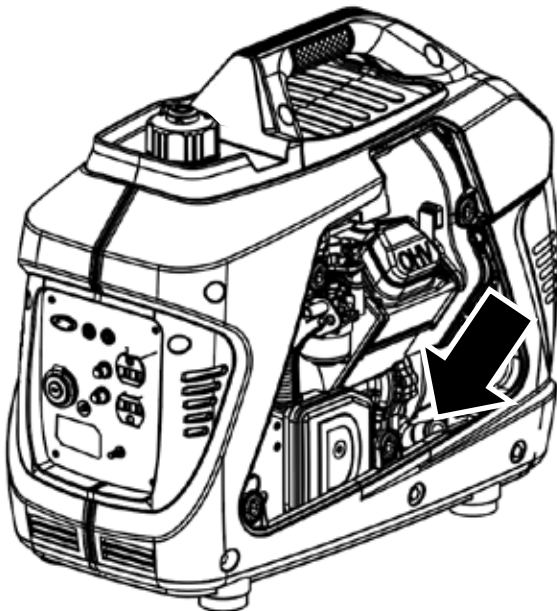

Figure 2: Oil Fill/Drain Plug

3. Using the supplied funnel and oil, pour the entire bottle of oil into the engine (see Figure 3).

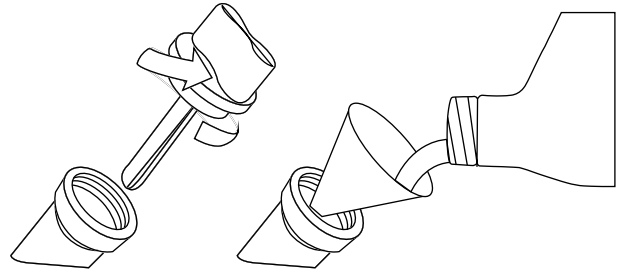

Figure 3: Oil Funnel

4. Do not overfill, if oil level is too high, oil will drain out through the fill plug. See correct oil level in Figure 4.

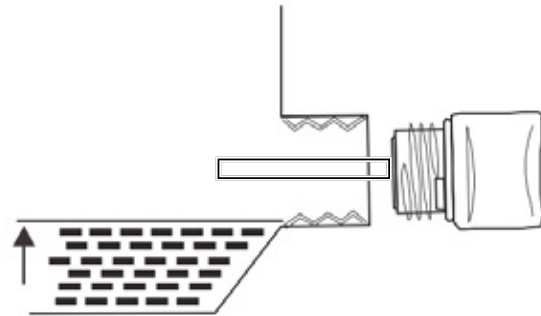

Figure 4: Engine Oil Correct Level

## ADDING/CHECKING ENGINE FLUIDS AND FUEL



**BEFORE ADDING/CHECKING ENGINE FLUIDS AND FUEL, REVIEW SAFETY SECTION STARTING ON PAGE 5.**

### DANGER



Filling the fuel tank with gasoline while the inverter is running can cause gasoline to leak and come in contact with hot surfaces that can ignite the gasoline.

Before starting the inverter, always check the level of:

- Engine oil
- Gasoline in the fuel tank

Once the inverter is started and the engine gets warm, it is not safe to add gasoline to the fuel tank or engine oil to the engine while the engine is running or the engine and muffler are hot.

## CHECKING AND / OR ADDING ENGINE OIL

### WARNING



Internal pressure can build in the engine crankcase while the engine is running. Removing the oil fill plug/dipstick while the engine is hot can cause extremely hot oil to spray out of the crankcase and can severely burn skin. Allow engine oil to cool for several minutes before removing the oil fill plug/dipstick.

The unit as shipped does not contain oil in the engine. You must add engine oil before starting the inverter for the first time. See *Initial Oil Fill* for instructions on checking engine oil level and the procedure for adding engine oil.

### NOTICE

The engine does not contain engine oil as shipped. Attempting to start the engine without adding engine oil will permanently damage internal engine components.

The engine is equipped with a low oil shutdown switch. If the oil level becomes low, the engine may shut down and not start until the oil is filled to the proper level.

The owner of the inverter is responsible to ensure the proper oil level is maintained during the operation of the inverter. Failure to maintain the proper oil level can result in engine damage.

## ADDING GASOLINE TO THE FUEL TANK

### WARNING



Never refuel the inverter while the engine is running.



Always turn the engine off and allow the inverter to cool before refueling.

### CAUTION



Avoid prolonged skin contact with gasoline. Avoid prolonged breathing of gasoline vapors.

**Required Gasoline** – Only use gasoline that meets the following requirements:

- Unleaded gasoline only
- Gasoline with maximum 10% ethanol added
- Gasoline with an 87 octane rating or higher

**Filling the Fuel Tank** – Follow the steps below to fill the fuel tank:

1. Shut off the inverter.
2. Allow the inverter to cool down so all surface areas of the muffler and engine are cool to the touch.
3. Move the inverter to a flat surface.
4. Clean area around the fuel cap.
5. Remove the fuel cap by rotating counterclockwise.

### NOTICE

Do not overfill the fuel tank. Spilled fuel will damage some plastic parts.

6. Slowly add gasoline into the fuel tank. Be very careful not to overfill the tank. The gasoline level should NOT be higher than the red ring (see Figure 5).
7. Install the fuel cap by rotating clockwise.

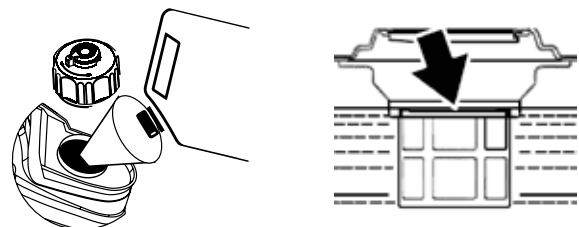

Figure 5: Maximum Gasoline Fill Level

## STARTING THE INVERTER



**BEFORE STARTING THE INVERTER, REVIEW SAFETY SECTION STARTING ON PAGE 5.**

For proper starting and operation of the inverter, make sure you review the inverter features and their descriptions starting on page 8.

Before attempting to start the inverter, verify the following:

- The engine is filled with engine oil (see Figure 4: *Engine Oil Correct Level* on page 13).
- The inverter is situated in a proper location (see *Location Selection* on page 11).
- The inverter is on a dry surface (see *Weather and Dry Surface* on page 11).
- All loads are disconnected from the inverter (see *No Connected Loads* on page 11).
- The inverter is properly grounded (see *Grounding the Inverter* on page 11)

<b>⚠ DANGER</b>	
	Never use the inverter in a location that is wet or damp. Never expose the inverter to rain, snow, water spray or standing water while in use. Protect the inverter from all hazardous weather conditions. Moisture or ice can cause a short circuit or other malfunction in the electrical circuit.
	Never operate the inverter in an enclosed area. Engine exhaust contains carbon monoxide. Only operate the inverter outside and away from windows, doors and vents.

### Starting Inverter

1. Check oil and fuel levels. If it is the first time starting make sure to add oil (see *Initial Oil Fill* on page 13).
2. Make sure the circuit breakers are properly set (see Figure 6).

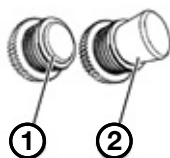

Figure 6: breakers 1-operating 2-tripped

3. For cold starting, turn the engine/fuel control switch to the **CHOKE** position (see Figure 7). **NOTE:** If you are re-starting turn knob to **RUN**.

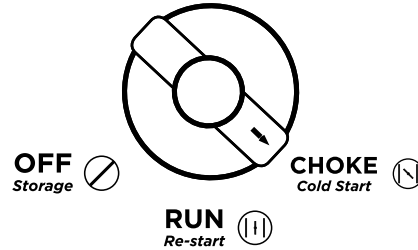

Figure 7: Turn Engine/Fuel Switch to CHOKE Position

4. Firmly grasp and pull the recoil handle slowly until you feel increased resistance. At this point, apply a rapid pull while pulling out from the inverter (see Figure 8).

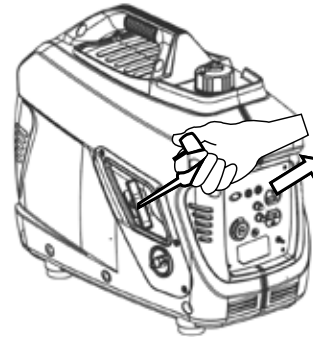

Figure 8: Pull the Recoil Handle away from Inverter

5. As the engine starts and stabilizes, turn the choke switch back in to the **RUN** position (see Figure 9).

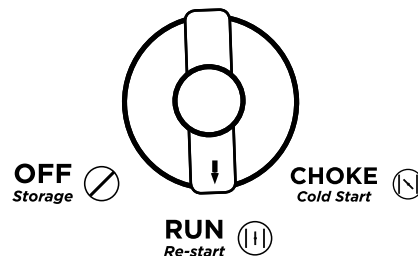

Figure 9: Turn Engine/Fuel Switch to RUN

6. Plug in electronic devices.



## STOPPING THE INVERTER

### Normal Operation

During normal operation, use the following steps to stop your inverter:

1. Remove any connected loads from the control panel receptacles.
2. Allow the inverter to run at “no load” to reduce and stabilize engine and alternator temperatures.
3. Move the engine control switch to the **OFF** position (see Figure 10) .

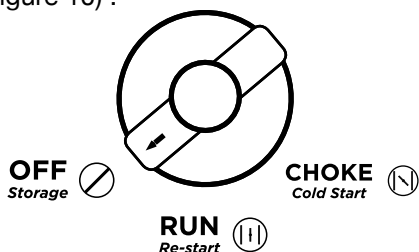

Figure 10: Turn Engine/Fuel Switch to OFF Position

### During an Emergency

If there is an emergency and the inverter must be stopped quickly, move the engine control switch to the **OFF** position immediately (see Figure 10).

## USING EFFICIENCY MODE

The inverter is equipped with an efficiency mode switch to minimize fuel consumption. In efficiency mode, the inverter will sense the load and adjust the engine RPM to the current load requirements. Efficiency mode should be used only after the inverter has been warmed up to operating temperature.

1. To turn on the efficiency mode, press the switch to the ON position).
2. If no load is present, the inverter RPM will drop down to an idle speed.
3. As a load is applied, the inverter will sense the load and engine RPM will increase according to the load applied.
4. To run the inverter at maximum power and RPM, press the efficiency mode switch to the OFF position.

## RESETTING THE RESET BREAKER

The inverter will trip the breaker and automatically disconnect from the load when the controls sense a predetermined overload condition. The inverter engine will continue to run, but there will not be any electrical output.

1. Turn off all devices and unplug them from the inverter.
2. Determine the wattage required from the devices being powered by the inverter. Make sure the wattage required does not exceed the maximum output of the inverter.
3. Press in the reset breaker to reset it (see Figure 11).

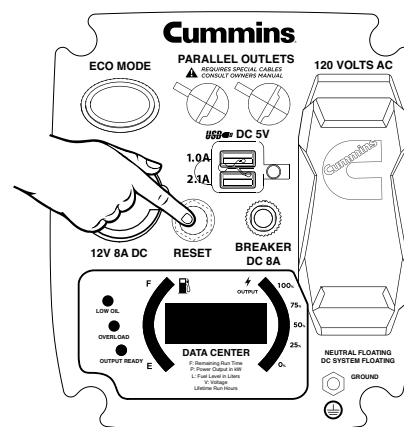

Figure 11: Press the reset breaker

4. Plug the devices in to the inverter.
5. Turn on the devices as needed.



**BEFORE PERFORMING MAINTENANCE ON THE INVERTER, REVIEW THE SAFETY SECTION STARTING ON PAGE 5, AS WELL AS THE FOLLOWING SAFETY MESSAGES.**

⚠ <b>WARNING</b>	
	Avoid accidentally starting the inverter during maintenance by removing the spark plug boot from the spark plug. For electric start inverters, also disconnect the battery cables from the battery (disconnect the black negative (-) cable first) and place the cables away from the battery posts to avoid arcing.
	Allow hot components to cool to the touch prior to performing any maintenance procedure.
	Internal pressure can build in the engine crankcase while the engine is running. Removing the oil fill plug/dipstick while the engine is hot can cause extremely hot oil to spray out of the crankcase and can severely burn skin. Allow engine oil to cool for several minutes before removing the oil fill plug/dipstick.
	Always perform maintenance in a well-ventilated area. Gasoline fuel and fuel vapors are extremely flammable and can ignite under certain conditions.

⚠ <b>CAUTION</b>	
	Avoid skin contact with engine oil or gasoline. Prolonged skin contact with engine oil or gasoline can be harmful. Frequent and prolonged contact with engine oil may cause skin cancer. Take protective measures and wear protective clothing and equipment. Wash all exposed skin with soap and water.

⚠ <b>WARNING</b>	
	Failure to perform periodic maintenance or not following maintenance procedures can cause the inverter to malfunction and could result in death or serious injury.

NOTICE	
Periodic maintenance intervals vary depending on inverter operating conditions. Operating the inverter under severe conditions, such as sustained high- load, high-temperature, or unusually wet or dusty environments, will require more frequent periodic maintenance. The intervals listed in the maintenance schedule should be treated only as a general guideline.	

Following the maintenance schedule is important to keep the inverter in good operating condition. The following is a summary of maintenance items by periodic maintenance intervals.

**TABLE 1: MAINTENANCE SCHEDULE - OWNER PERFORMED**

Maintenance Item	Before Every Use	After First 20 Hours or First Month of Use	After 50 Hours of Use or Every 6 Months	After 100 Hour of Use or Every 6 Months	After 300 Hours of Use or Every Year
<b>Engine Oil</b>	Check Level	Change	Change	-	-
<b>Cooling Features</b>	Check/Clean	-	-	-	-
<b>Air Filter</b>	Check	-	Clean*	-	Replace
<b>Spark Plug</b>	-	-	-	Check/Clean	Replace
<b>Spark Arrestor</b>	-	-	-	Check/Clean	-

\*Service more frequently if operating in dry and dusty conditions

## ENGINE OIL MAINTENANCE

### Engine Oil Specification

1. Only use the engine oil specified in Figure 12.
2. Only use 4-stroke/cycle engine oil. **NEVER USE 2-STROKE/CYCLE OIL.** Synthetic oil is an acceptable substitute for conventional oil.

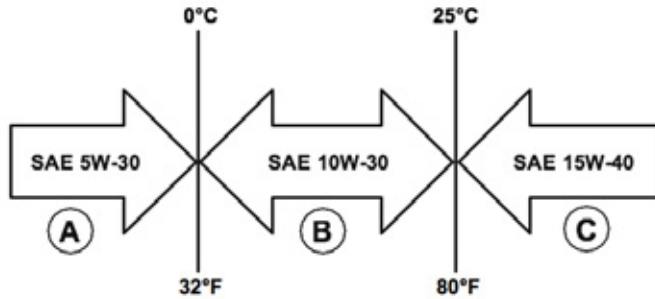
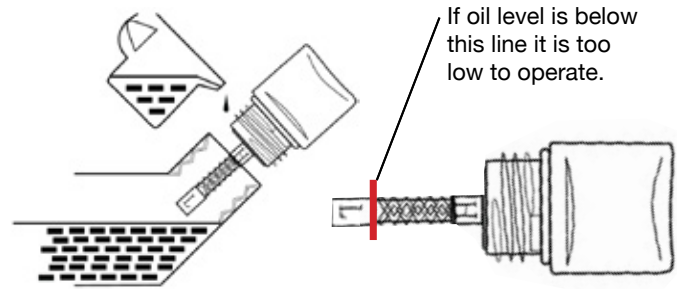

Figure 12: Recommended Oil



NOTICE
<p>Engine oil must always be checked and added when the inverter is on a flat, level surface, or an inaccurate reading may result, causing serious engine damage.</p>

## CHECKING ENGINE OIL

NOTICE
<p>Always maintain proper engine oil level. Failure to maintain proper engine oil level could result in severe damage to the engine and/or shorten the life of the engine.</p> <p>Always use the specified engine oil. Failure to use the specified engine oil can cause accelerated wear and/or shorten the life of the engine.</p>

Engine oil level should be checked before every use.

1. Always operate or maintain the inverter on a flat surface.
2. Stop engine if running.
3. Let engine sit and cool for several minutes (allow crankcase pressure to equalize).
4. Remove the engine service panel to access the oil fill/drain plug.
5. With a damp rag, clean around the oil fill/drain plug.
6. Remove the oil fill/drain plug.
7. Check oil level: When checking the engine oil, remove the oil fill/ drain plug.
  - The oil level is acceptable if oil is visible at the bottom of the threads of the oil fill plug.
  - If oil level is low, add to the correct level using the supplied oil fill bottle. Do not overfill the oil crankcase.

## ADDING ENGINE OIL

1. Always operate or maintain the inverter on a flat surface.
2. Stop engine if running.
3. Let engine sit and cool for several minutes (allow crankcase pressure to equalize).
4. Remove the engine service panel to gain access to the oil fill/drain plug.
5. Thoroughly clean around the oil fill/drain plug.
6. Remove the oil fill/drain plug.
7. Select the proper engine oil as specified in Figure 12.
8. Using the supplied oil funnel, slowly add engine oil to the engine. Stop frequently to check the oil level and avoid overfilling.
9. Continue to add oil until the oil is at the correct level.

## CHANGING ENGINE OIL

1. Stop the engine.
2. Let engine sit and cool for several minutes (allow crankcase pressure to equalize).
3. Remove the engine service panel to gain access to the oil fill/drain plug.
4. Place oil pan (or suitable container) under the oil drain hole (see Figure 13).

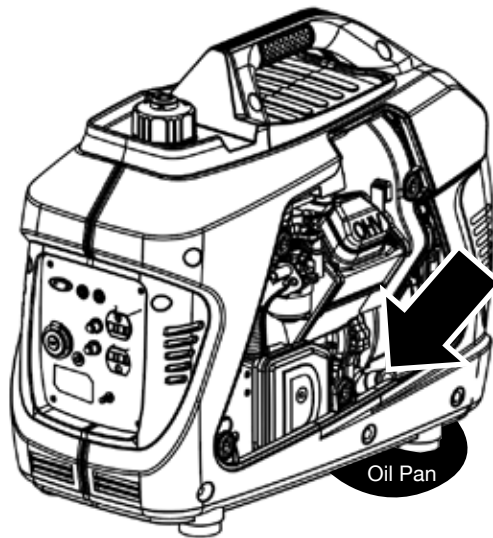

Figure 13: Place oil pan under oil drain hole

5. With a damp rag, thoroughly clean around the oil fill/drain plug.
6. Tilt the inverter so the oil drains down through the hole in the bottom of the inverter into the container.
7. Allow oil to completely drain.
8. Fill crankcase with oil following the steps outlined in *Adding Engine Oil* on page 18.
9. Dispose of used engine oil properly.

### NOTICE

Never dispose of used engine oil by dumping the oil into a sewer, on the ground, or into groundwater or waterways. Always be environmentally responsible. Follow the guidelines of the EPA or other governmental agencies for proper disposal of hazardous materials. Consult local authorities or reclamation facility.

## AIR FILTER MAINTENANCE

### ⚠ WARNING



Never use gasoline or other flammable solvents to clean the air filter. Use only household detergent soap to clean the air filter.

### Cleaning the Air Filter

The air filter must be cleaned after every 50 hours of use or 3 months (frequency should be increased if inverter is operated in a dusty environment).

1. Turn off the inverter and let it cool for several minutes if running.
2. Remove the engine service panel to gain access to the air filter.
3. Unscrew the air cleaner cover and tip the cover down (see Figure 14).

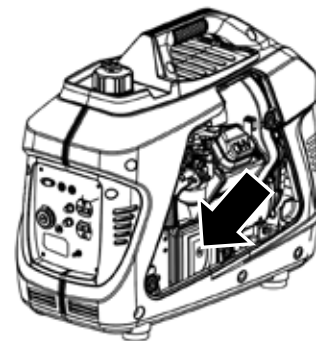

Figure 14: Remove air filter screw

4. Remove the foam element from the air cleaner housing.
5. Wash the foam air filter element by submerging the element in a solution of household detergent soap and warm water. Slowly squeeze the foam to thoroughly clean.

### NOTICE

NEVER twist or tear the foam air filter element during cleaning or drying. Only apply slow but firm squeezing action.

6. Rinse in clean water by submerging the air filter element in fresh water and applying a slow squeezing action (see Figure 15).



Figure 15

## NOTICE

Never dispose of soap cleaning solution used to clean the air filter by dumping the solution into a sewer, on the ground, or into ground water or waterways. Always be environmentally responsible. Follow the guidelines of the EPA or other governmental agencies for proper disposal of hazardous materials. Consult local authorities or reclamation facility.

7. Dispose of used soap cleaning solution properly.
8. Dry the air filter element by again applying a slow firm squeezing action.
9. Return the air filter element to its position in the air cleaner housing.
10. Install the air cleaner cover, making sure the tabs lock into place.
11. Install the engine service panel.

## DRAINING THE FLOAT BOWL

1. Remove the engine service panel to access the carburetor.
2. Locate the clear plastic hose from the float that is exiting out the bottom of the inverter, and place a suitable container under it to catch the drained fuel (see Figure 16).

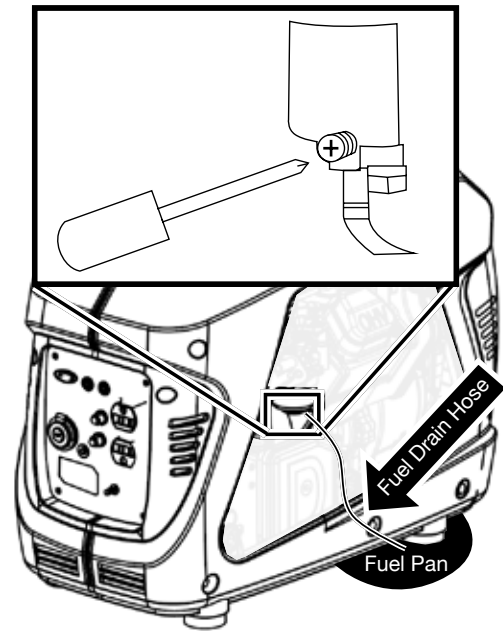

Figure 16: Locate fuel drain screw and fuel drain hose

3. Loosen the float bowl drain screw (see Figure 16) until fuel is seen draining from the float bowl.
4. Allow fuel to drain into the container, and then tighten the float bowl drain screw.

## NOTICE

Never dispose of fuel by dumping fuel into a sewer, on the ground, or into groundwater or waterways. Always be environmentally responsible. Follow the guidelines of the EPA or other governmental agencies for proper disposal of hazardous materials. Consult local authorities or reclamation facility.

5. Install the engine service panel.

## SPARK PLUG MAINTENANCE

The spark plug must be checked and cleaned after every 100 hours of use or 6 months and must be replaced after 300 hours of use or every year.

1. Stop the inverter and let it cool for several minutes if running.
2. Move the inverter to a flat, level surface.
3. Remove the engine service panel by unlocking knob and locate spark plug boot at top of engine (see Figure 17).

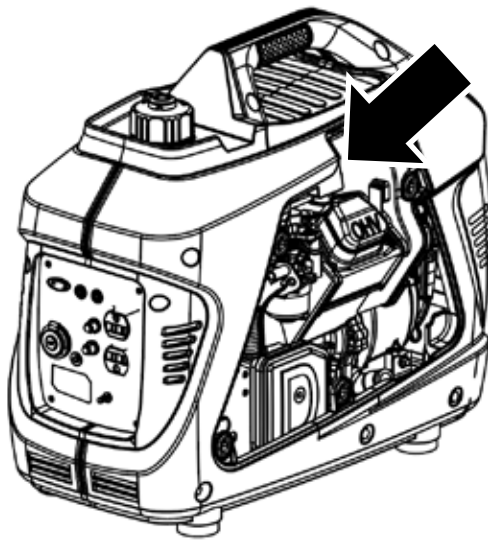

Figure 17: Locate spark plug

4. Remove the spark plug boot by firmly pulling the plastic spark plug boot handle directly away from the engine.

### NOTICE

Never apply any side load or move the spark plug laterally when removing the spark plug. Applying a side load or moving the spark plug laterally may crack and damage the spark plug boot.

5. Clean area around the spark plug.
6. Using the spark plug socket wrench provided, remove the spark plug from the cylinder head (see Figure 18).

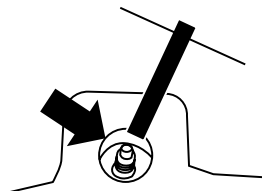
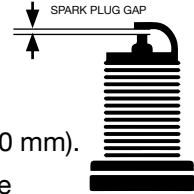

Figure 18: Using spark plug wrench remove the spark plug

7. Place a clean rag over the opening created by the removal of the spark plug to make sure no dirt can get into the combustion chamber.

8. Inspect the spark plug for:

- Cracked or chipped insulator
- Excessive wear
- Spark plug gap of 0.032 in. (0.80 mm).



If the spark plug fails any one of the conditions listed above, replace the plug.

### NOTICE

Only use the recommended spark plug. See chart below. Using a non-recommended spark plug could result in damage to the engine.

9. Install the spark plug by carefully following the steps outlined below:
  - a. Carefully insert the spark plug back into the cylinder head. Hand-thread the spark plug until it bottoms out.
  - b. Using the spark plug socket wrench provided, turn the spark plug to ensure it is fully seated.
  - c. Replace the spark plug boot, making sure the boot fully engages the spark plug's tip.
  - d. Install the spark plug access cover.

### Recommended Spark Plug Replacement:

Cummins	Torch Spark plug	NGK	Bosch	AC Delco
A058U948	E6RTC	BPR6HS	WR7BC	R43FS

## CLEANING THE SPARK ARRESTOR

Check and clean the spark arrestor after every 100 hours of use or 6 months.

1. Stop the inverter and let it cool for several minutes if running.
2. Move the inverter to a flat, level surface.
3. Remove the screws holding the muffler cover in place (see Figure 19).

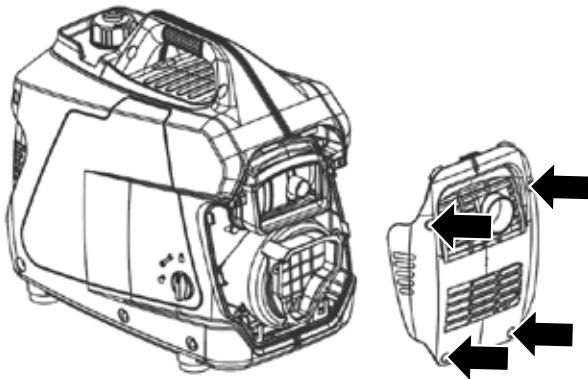



Figure 19: Remove screws holding muffler cover

4. Loosen the clamp holding the spark arrestor onto the muffler.
5. Slide the spark arrestor band clamp off the spark arrestor screen.
6. Pull the spark arrestor screen off the muffler exhaust pipe.
7. Using a wire brush, remove any dirt and debris that may have collected on the spark arrestor screen.
8. If the spark arrestor screen shows signs of wear (rips, tears or large openings in the screen), replace the spark arrestor screen.
9. Install the spark arrestor components in the following order:
  - a. Place spark arrestor screen over the muffler exhaust pipe. Push on the screen until it fully bottoms out.
  - b. Place the spark arrestor band clamp over the screen and tighten with a flathead screwdriver
10. Replace the discharge gate.

## CHECKING AND ADJUSTING VALVE LASH

**⚠ CAUTION**

 Checking and adjusting valve lash must be done when the engine is cold.

1. Remove the rocker arm cover and carefully remove the gasket. If the gasket is torn or damaged, it must be replaced.
2. Remove the spark plug so the engine can be rotated more easily.
3. Rotate the engine to top dead center (TDC) of the compression stroke. Looking through the spark plug hole, the piston should be at the top.
4. Both the rocker arms should be loose at TDC on the compression stroke. If they are not, rotate the engine 360°.
5. Insert a feeler gauge between the rocker arm and the push rod and check for clearance (see Figure 20). See Table 1 for valve lash specifications.

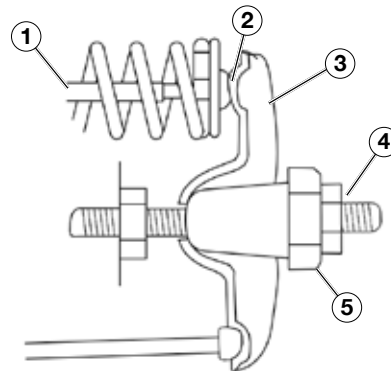

Figure 20  
 (1) Push Rod, (2) Feeler Gauge Area  
 (3) Rocker Arm, (4) Jam Nut, (5) Adjusting Nut

Table 1: Standard Valve Lash

	Intake Valve	Exhaust Valve
<b>Valve Lash</b>	.0023-.0039in (.06-.10mm)	.0031-.0048in (.08-.12mm)
<b>Bolt Torque</b>	8-12N.m	8-12N.m

6. If an adjustment is required, hold the adjusting nut and loosen the jam nut.
7. Turn the adjusting nut to obtain the correct valve lash. When the valve lash is correct, hold the adjusting nut and tighten the jam nut to 106 in-lb (12 N•m).
8. Recheck the valve lash after tightening the jam nut.
9. Perform this procedure for both the intake and exhaust valves.
10. Install the rocker arm cover, gasket and spark plug.

**CLEANING THE INVERTER**

It is important to inspect and clean the inverter before every use.

**Clean All Engine Air Inlet and Outlet Ports** – Make sure all engine air inlet and outlet ports are clean of any dirt and debris to ensure the engine does not run hot.

**STORAGE****WARNING**

Never store an inverter with fuel in the tank indoors or in a poorly ventilated area where the fumes can come in contact with an ignition source such as a: 1) pilot light of a stove, water heater, clothes dryer or any other gas appliance; or 2) spark from an electric appliance.

**NOTICE**

Gasoline stored for as little as 60 days can go bad, causing gum, varnish and corrosive buildup in fuel lines, fuel passages and the engine. This corrosive buildup restricts the flow of fuel, preventing an engine from starting after a prolonged storage period.

Proper care should be taken to prepare the inverter for any storage

1. Clean the inverter as outlined in *Cleaning the Inverter*.
2. Siphon all gasoline from the fuel tank as best as possible.
3. Start the engine and allow the inverter to run until all the remaining gasoline in the fuel lines and carburetor is consumed and the engine shuts off.
4. Drain any remaining fuel from the float bowl. See *Draining the Float Bowl* on page 20.
5. Change the oil (see *Changing Engine Oil* on page 19).
6. Remove the spark plug (see *Spark Plug Maintenance* on page 21) and place about 1 tablespoon of oil in the spark plug opening. While placing a clean rag over the spark plug opening, slowly pull the recoil handle to allow the engine to turn over several times. This will distribute the oil and protect the cylinder wall from corroding during storage.
7. Replace the spark plug (see *Spark Plug Maintenance* on page 21).
8. Move the inverter to a clean, dry place for storage.



**⚠ WARNING**



Before attempting to service or troubleshoot the inverter, the owner or service technician must first read the owner's manual and understand and follow all safety instructions. Failure to follow all instructions may result in conditions that can lead to voiding of the EPA certification or product warranty, serious personal injury, property damage or even death.

PROBLEM	POTENTIAL CAUSE	SOLUTION
Engine is running, but no electrical output.	1. Reset breaker is tripped.	1. Reset the reset breaker (see page 16).
	2. The power cord's plug connector is not fully engaged in the inverter's outlet.	2. Verify plug connector is firmly engaged in the inverter's outlet.
	3. Faulty or defective power cord	3. Replace power cord.
	4. Faulty or defective electrical appliance	4. Try connecting a known good appliance to verify the inverter is producing electrical power.
Engine will not start or remain running while trying to start.	1. Inverter is out of gasoline.	1. Add gasoline to the inverter (see page 14).
	2. Fuel flow is obstructed.	2. Inspect and clean fuel delivery passages.
	3. Dirty air filter	3. Check and clean the air filter (see page 19).
	4. Low oil level shutdown switch is preventing the unit from starting.	4. Check oil level and add oil if necessary (see page 18).
	5. Spark plug boot is not fully engaged with the spark plug tip.	5. Firmly push down on the spark plug boot to ensure the boot is fully engaged.
	6. Spark plug is faulty.	6. Remove and check the spark plug. Replace if faulty (see pages 21).
	7. Dirty/plugged spark arrestor	7. Check and clean the spark arrestor (see page 22).
	8. Stale fuel	8. Drain fuel and replace with fresh fuel.
Inverter suddenly stops running.	1. Inverter is out of fuel.	1. Check fuel level (see page 14). Add fuel if necessary.
	2. The low oil shut down switch has stopped the engine.	2. Check oil level and add oil if necessary (see page 18).
	3. Too much load	3. Restart the inverter and reduce the load.
Engine runs erratic; does not hold a steady RPM.	1. Choke was left in the <b>CHOKE</b> position.	1. Move choke to the <b>RUN</b> position
	2. Dirty air filter	2. Clean the air filter (see page 19).
	3. Applied loads maybe cycling on and off	3. As applied loads cycle, changes in engine speed may occur; this is a normal condition.

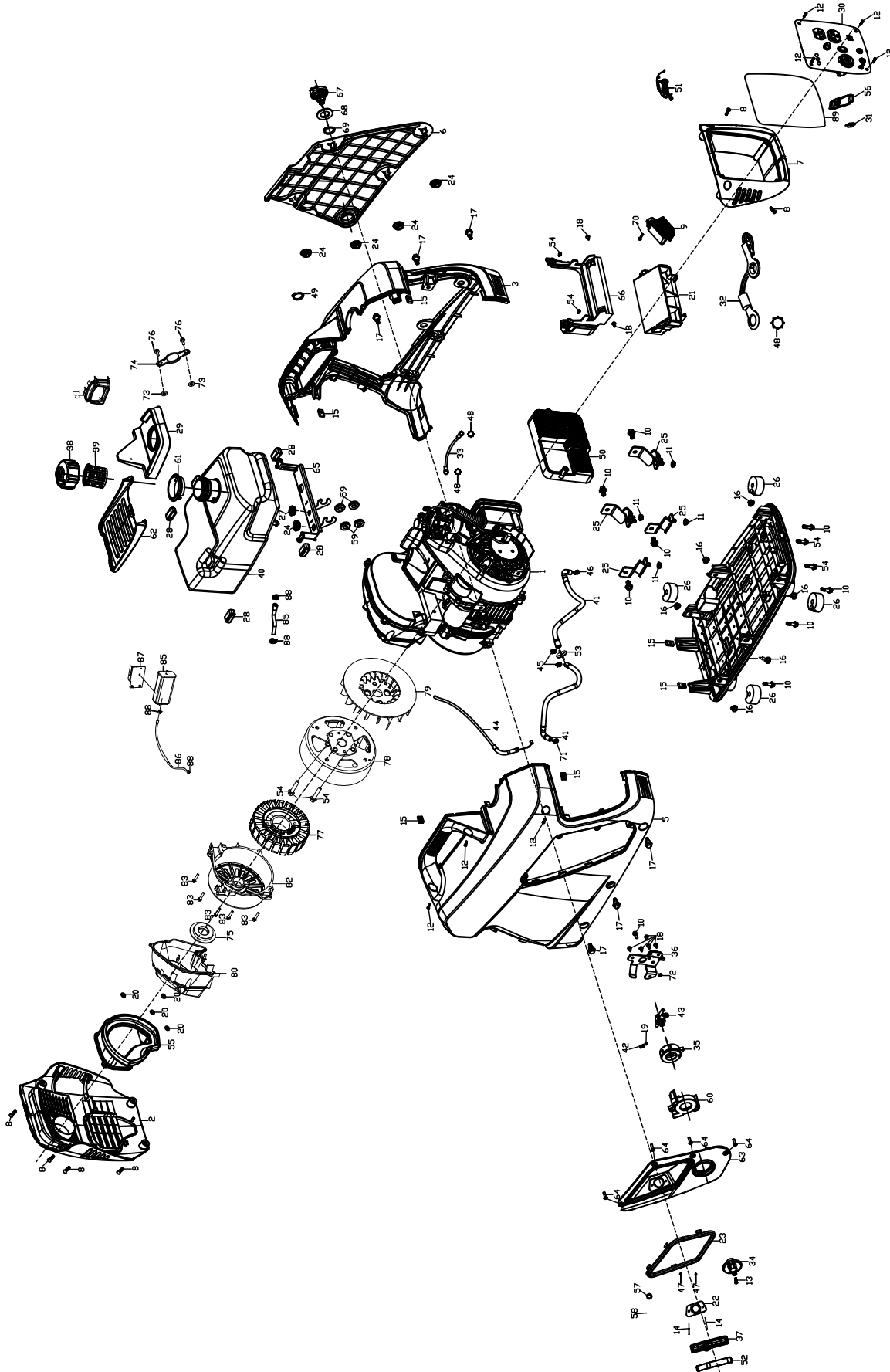

# EXPLODED VIEW PART NO.

---

1-2019

#	PART NO.	DESCRIPTION
12	A058U965	CROSS RECESSED PAN HEAD SCREW M5×12
17	A058U984	HEX FLANGE SCREWS
40	A058U989	FUEL TANK
50	A058U953	INVERTER
NA	A058U946	Maintenance Kit
NA	A058U947	Generator Cover
NA	A058U945	Parallel Kit

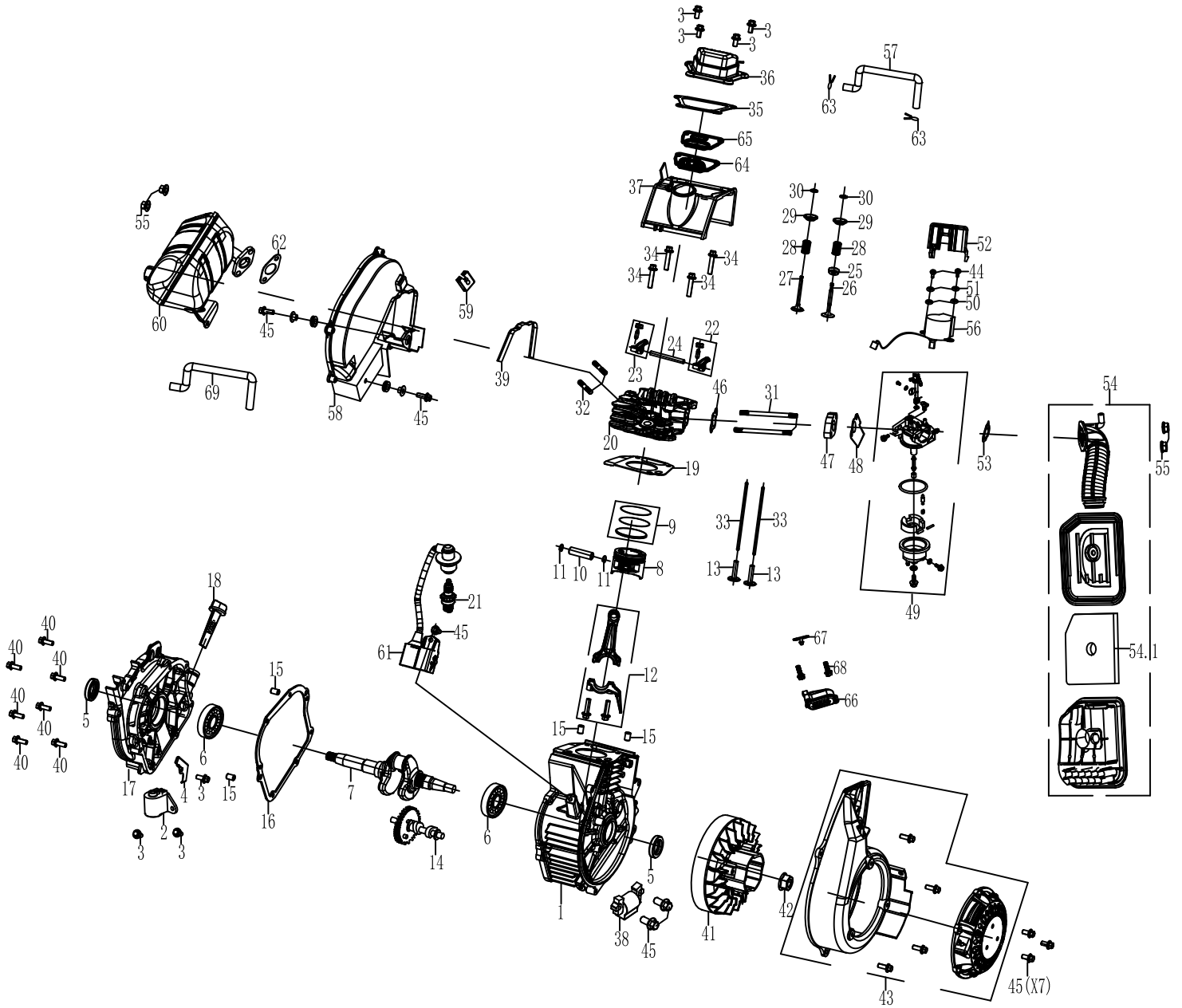

# ENGINE VIEW PART NO.

1-2019

#	PART NO.	DESCRIPTION
2	A058U949	SWITCH ASSEMBLY,OIL LEVEL
13	A058U998	LIFTER,VALVE
19	A058U983	GASKET,CYLINDER HEAD
21	A058U948	SPARK PLUG
23	A058V000	EXHAUST VALVE ROCKER ASSY
24	A058U999	ROCKSHAFT
25	A058V001	INLET VALVE SPRING SEAT
27	A058U988	VALVE EXHAUST
28	A058V002	SPRING,VALVE
29	A058U991	SEAT, VALVE SPRING,IN
30	A058U987	VALVE LOCK CLAMP
33	A058U985	ROD,PUSH
35	A058U995	PACKING, HEADCOVER
36	A058U990	COVER COMP,CYLINDER HEAD
40	A058U994	BOLT M6X20
45	A058U986	BOLT M6X16
49	A058U950	CARBURETOR ASSEMBLY
53	A058U997	AIR CLEANER GASKET
54.1	A058U954	AIR CLEANER ELEMENT
56	A058U952	STEPPER MOTOR
60	A058U996	MUFFLER ASSY
61	A058U951	IGNITION COIL
62	A058U992	EXHAUST GASKET (INTAKE)
0	A058V023	HIGH ALTITUDE CARBURETOR 98CC

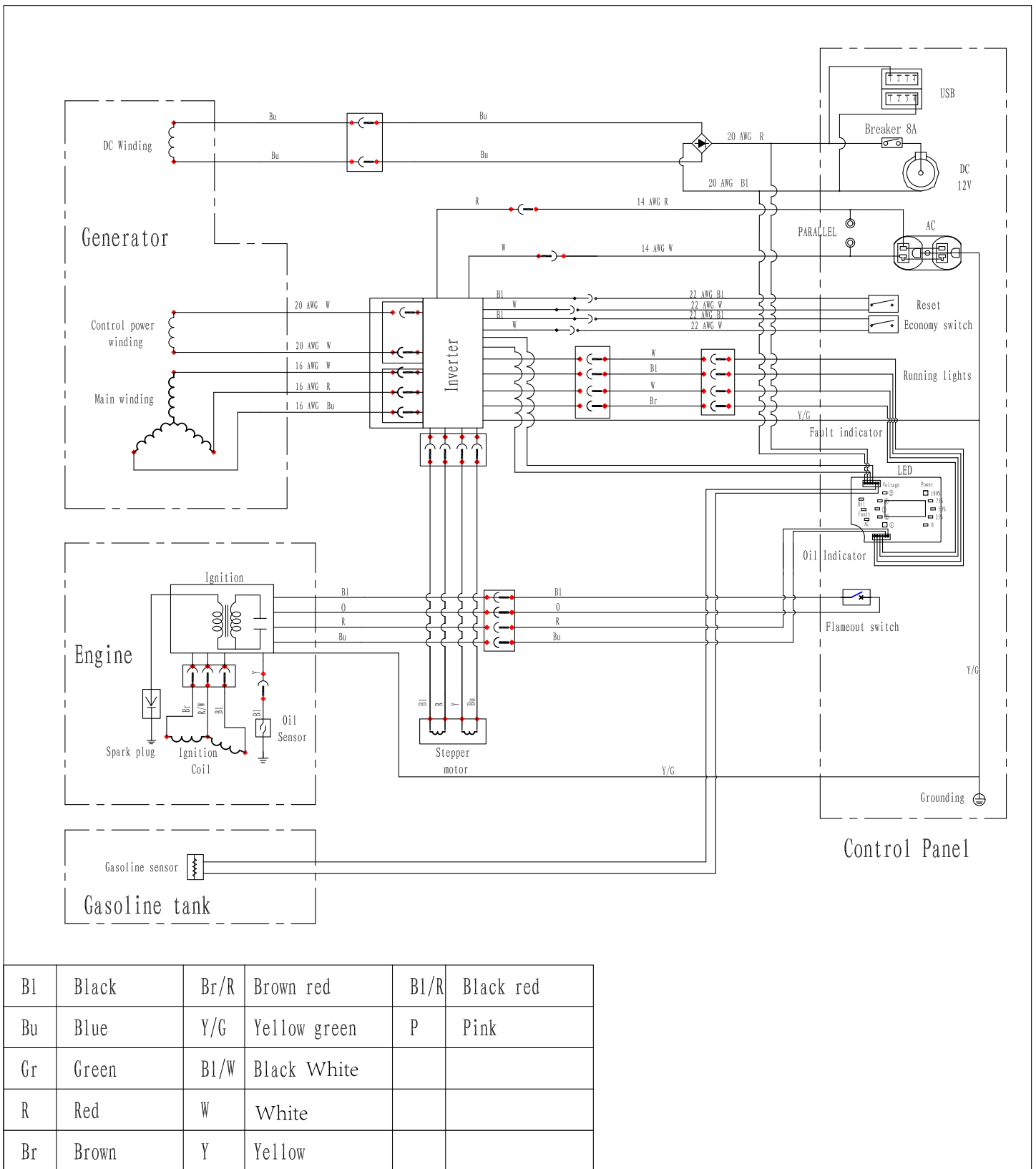



[power.cummins.com](http://power.cummins.com)

Copyright © 2019 Cummins Inc. All rights reserved.

Cummins, Onan and the "C" logo are registered trademarks of Cummins Inc. and its subsidiaries.

Other company, product, or service names may be trademarks or service marks of others.

Specifications are subject to change without notice.

