

PATIENT SLING

1. SLING STYLE AND SIZE

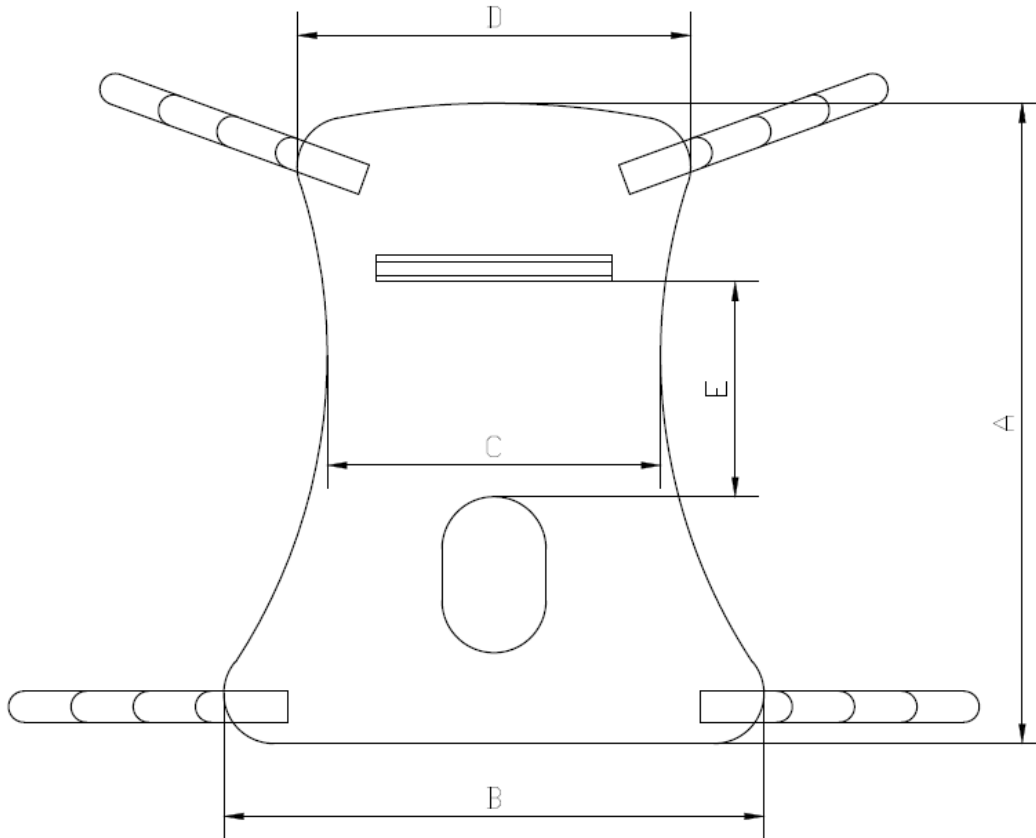

TWO STYLES:

- FULL BODY SLING
- FULL BODY SLING WITH COMMUNE OPENING

FOUR COLOR CODED POSITIONING STRAPS

LOADING CAPACITY: 660 LBS. / 30 KGS.

SIZE SPECIFICATION LISTED BELOW:

SIZE	A	B	C	D	E
S	42.5" / 1,080 mm	33" / 840 mm	23.6" / 600 mm	30" / 760 mm	13.8" / 350 mm
M	49.2" / 1,250 mm	42.5" / 1,080 mm	24.8" / 630 mm	34.6" / 880 mm	15.7" / 400 mm
L	47.2" / 1,200 mm	47.2" / 1,200 mm	26.4" / 670 mm	39.3" / 1,000 mm	15.7" / 400 mm
XL	57.4" / 1,460 mm	47.2" / 1,200 mm	26.8" / 680 mm	36.2" / 920 mm	17.7" / 450 mm

2. SLING OPERATION



After each laundering, inspect sling for wear, tears, and loose stitching. Bleached, torn, cut, frayed, or broken slings are unsafe and could result in injury. Discard immediately.

Positioning the Full Body Sling

- With an attendant on each side of the bed and up against the mattress, the attendant on the right-hand side of the bed should elevate the left knee and position his/her left-hand on the elevated knee and his/her right-hand under the patient's left shoulder. Slowly push on the knee and assist with a slight lift of the shoulder and the patient will easily roll onto their side.
- Place the sling onto the mattress.
- Roll the patient onto his/her back.
- Pull the sling across the mattress until smooth.

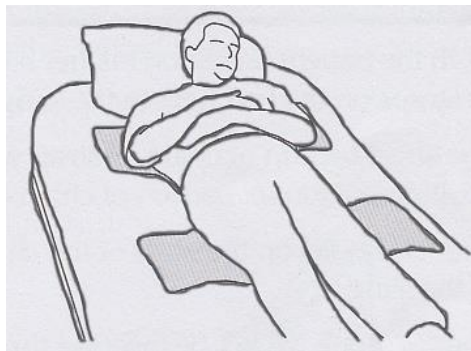
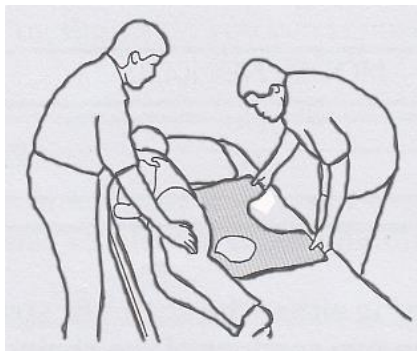
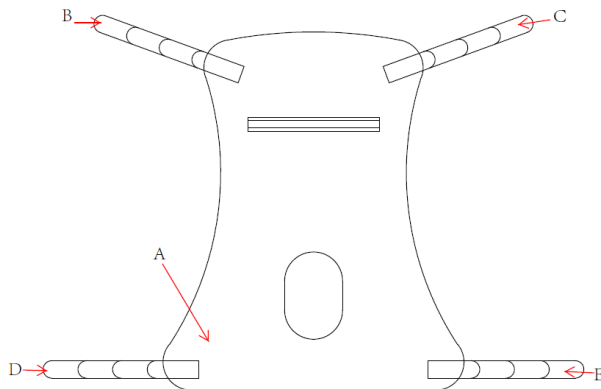

Attaching the Sling to the Patient Lift

- Attach the strap to the hanger bar. By adjusting the strap to the different color coded links you can reposition the patient into various reclining and upright positions.
- With the sling positioned under the patient and support bars in place, move the lift into position to attach the sling straps to the hanger bar.
- Refer to Lifting the Patient in the Patient Lift Owner's Manual.

Two positions option for the Sling.

- Seated position
 - Use B and C in the short strap position, D and E in the long strap position.
 - Use the patient lift to lift the patient straight up and put him/her in a wheelchair or chair.

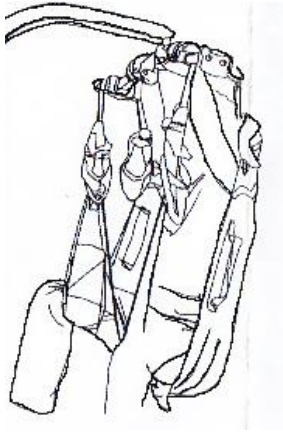

- Reclining position
 - Using B and C in the long strap position, D and E in the short strap position.
 - Slightly lift up the patient, and put him/her on the bed.

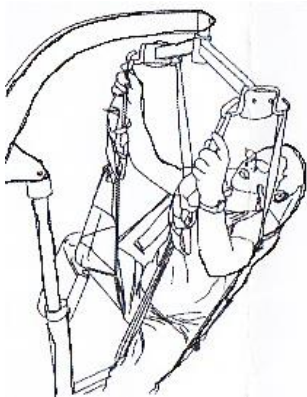

Remark:

1. While operating the lift the nurse or caregiver must firmly hold the back handle to secure the patient position.
2. To avoid any discomfort to the patient ensure that the patient's legs are straight and not bent or curved.

3. CARE

NOTE: Laundering should always be done with dark colors. The sling should be washed regularly in a water temperature not to exceed 180°F (82°C). DO NOT bleach. Air dry or dry at low temperature. Inspect with each use.