

USER MANUAL



FOR MODELS:

MXR3500S

Digital Inverter Generator

Peak Watts: 3500W(Gas)/3100W(LPG)

Running Watts: 3200W(Gas)/2800W(LPG)

DISCLAIMERS:

All information, illustrations and specifications in this manual are based on the latest information available at the time of publishing. The illustrations used in this manual are intended as representative reference views only. Moreover, because of our continuous product improvement policy, we may modify information, illustrations and/or specifications to explain and/or exemplify a product, service or maintenance improvement. We reserve the right to make any change at any time without notice. Some images may vary depending upon which model is shown.

ALL RIGHTS RESERVED:

No part of this publication may be reproduced or used in any form by any means - graphic, electronic or mechanical, including photocopying, recording, taping or information storage and retrieval systems - without the written permission of Chongqing Guoyu Technology Co., Ltd

⚠ DANGER

This manual contains important instructions for operating this inverter generator. For your safety and the safety of others, be sure to read this manual thoroughly before operating the generator. Failure to properly follow all instructions and precautions can cause you and others to be seriously hurt or killed.

TECHNICAL SPECIFICATIONS

Model Number	Running Watts	Peak Watts	Fuel Tank Size (Gal)	Rated Speed (RPM)	Ignition Type	Spark Plug	Engine Disp(cc)	Stroke X Bore	Oil Capacity (Gal)	Oil Type
MXR3500S	3200W(Gas) 2800W(LPG)	3500W(Gas) 3100W(LPG)	1.58	4600	CDI	A5RTC	145	64X45	0.12	10W30



LIMITED WARRANTY

- 1. DURATION:** One (1) year from the date of purchase by the original purchaser (retail customer) on products used solely for consumer applications; if a product is used for business, commercial, or industrial applications, the warranty period will be limited to ninety (90) days from the date of purchase.
- 2. WHO GIVES THIS WARRANTY (WARRANTOR):**
Chongqing Guoyu Technology Co., Ltd
- 3. WHO RECEIVES THIS WARRANTY (PURCHASER):**
The original purchaser (other than for purposes of resale) of the MAXPEEDINGRODS inverter.
- 4. WHAT PRODUCTS ARE COVERED BY THIS WARRANTY:**
Any portable generator supplied or manufactured by Warrantor.
- 5. WHAT IS COVERED UNDER THIS WARRANTY:**
Substantial defects on material and workmanship which occur within the duration of the warranty period.
- 6. WHAT IS NOT COVERED UNDER THIS WARRANTY:**
 - A. Transportation charges for sending the product to Warrantor or its authorized service representative for warranty service, or for shipping repaired or replacement products back to the customer; these charges must be borne by the customer.
 - B. Damages caused by abuse, accident, shipping, misuse, overloading, modification, and the effects of corrosion, erosion and normal wear and tear.
 - C. Warranty is voided if the customer fails to install, maintain and operate the product in accordance with the instructions and recommendations set forth in the owner's manual(s), or if the product is used as rental equipment.
 - D. Pre-delivery service, i.e. assembly, oil or lubricants, and adjustment.
 - E. Items or service that are normally required to maintain the product, i.e. lubricants and filters.
 - F. Warrantor will not pay for repairs or adjustments to the product, or for any costs or labour, performed without Warrantor's prior authorization.

EXCLUSIONS AND LIMITATIONS: Warrantor makes no other warranty of any kind, express or implied. Implied warranties, including warranties of merchantability and of fitness for a particular purpose, are hereby disclaimed. This warranty service described above is the exclusive remedy under this warranty; liability for incidental and consequential damages is excluded to the extent permitted by law.
- 7. RESPONSIBILITIES OF PURCHASER UNDER THIS WARRANTY:**
 - A. The purchaser must provide dated proof of purchase and must notify Warrantor within the warranty period.
 - B. Deliver or ship the serviced generator or component to the nearest Warrantor's authorized service representative. Freight costs, if any, must be borne by the purchaser.
- 8. Having any questions? Please do contact us via your purchasing channel for quick help. We guarantee you will get satisfied and quickest solution through this way.**

TABLE OF CONTENTS

TECHNICAL SPECIFICATIONS	2	MAINTENANCE	16
LIMITED WARRANTY	3	Maintenance Schedule	16
SAFETY	5	Engine Oil Maintenance	17
Safety Definitions	5	Checking Engine Oil	17
Safety Symbol Definitions	5	Adding Engine Oil	17
General Safety Rules	6	Changing Engine Oil	18
Safety Labels and Decals	7	Air Filter Maintenance	18
UNPACKING	7	Cleaning the Air Filter	18
FEATURES	8	Draining the Float Bowl	19
Basic Inverter Features MXR3500S	8	Spark Plug Maintenance	20
Control Panel Features MXR3500S	9	Cleaning the Spark Arrestor	21
OPERATION	10	Cleaning the Inverter	21
Before Starting the Inverter	10	Storage	21
Location Selection	10	TROUBLESHOOTING	22
Weather	10	SCHEMATIC	23
Dry Surface	10	MXR3500S Schematic	23
No Connected Loads	10		
Grounding the Inverters	10		
Powercord	11		
Inverter Paralleling Operation	11		
Initial Oil Fill	12		
Connect the Battery Line	12		
Adding/Checking Engine Fluids and Fuel	13		
Checking and/or Adding Engine Oil	13		
Adding Gasoline to the Fuel Tank	13		
Starting MXR3500S	14		
Stopping the Inverter	15		
Using Efficiency Mode	15		
Resetting the Reset Breaker	15		

SAFETY

SAFETY DEFINITIONS

The words DANGER, WARNING, CAUTION and NOTICE are used throughout this manual to highlight important information. Be certain that the meanings of these alerts are known to all who work on or near the equipment.



This safety alert symbol appears with most safety statements. It means attention, become alert, your safety is involved! Please read and abide by the message that follows the safety alerts symbol.

DANGER

Indicates a hazardous situation which, if not avoided, will result in death or serious injury.

WARNING

Indicates a hazardous situation which, if not avoided, could result in death or serious injury.

CAUTION

Indicates a hazardous situation which, if not avoided, could result in minor or moderate injury.

NOTICE

Indicates a situation which can cause damage to the generator, personal property and/or the environment, or cause the equipment to operate improperly.

DANGER

Connection of the product to a building's electrical system is not applicable.

NOTE: Indicates a procedure, practice or condition that should be followed in order for the generator to function in the manner intended.

SAFETY SYMBOL DEFINITIONS

Symbol	Description
	Safety Alert Symbol
	Asphyxiation Hazard
	Burn Hazard
	Burst/Pressure Hazard
	Don't leave tools in the area
	Electrical Shock Hazard
	Explosion Hazard
	Fire Hazard
	Lifting Hazard
	Pinch-Point Hazard
	Read Manufacturer's Instructions
	Read Safety Messages Before Proceeding
	Wear Personal Protective Equipment (PPE)

SAFETY

GENERAL SAFETY RULES

DANGER



Never use the inverter in a location that is wet or damp. Never expose the inverter to rain, snow, water spray or standing water while in use. Protect the inverter from all hazardous weather conditions. Moisture or ice can cause a short circuit or other malfunction in the electrical circuit.



Never operate the inverter in an enclosed area. Engine exhaust contains carbon monoxide. Only operate the inverter outside and away from windows, doors and vents.

WARNING



Voltage produced by the inverter could result in death or serious injury.

- Never operate the inverter in rain or a flood plain unless proper precautions are taken to avoid being subject to rain or a flood.
- Never use worn or damaged extension cords.
- Always have a licensed electrician connect the inverter to the utility circuit.
- Never touch an operating inverter if the inverter is wet or if you have wet hands.
- Never operate the inverter in highly conductive areas such as around metal decking or steel works.
- Always use grounded extension cords. Always use three-wire or double-insulated power tools.
- Never touch live terminals or bare wires while the inverter is operating.
- Be sure the inverter is properly grounded before operating.

WARNING



Gasoline and gasoline vapors are extremely flammable and explosive under certain conditions.

- Always refuel the generator outdoors, in a well-ventilated area.
- Never remove the fuel cap with the engine running.
- Never refuel the inverter while the engine is running. Always turn engine off and allow the generator to cool before refueling.
- Only fill fuel tank with gasoline.
- Keep sparks, open flames or other form of ignition (such as match, cigarette, static electric source) away when refueling.
- Never overflow the fuel tank. Leave room for fuel to expand. Overfilling the fuel tank can result in a sudden overflow of gasoline and result in spilled gasoline coming in contact with HOT surfaces. Spilled fuel can ignite. If fuel is spilled on the inverter, wipe up any spills immediately. Dispose of rag properly. Allow area of spilled fuel to dry before operating the inverter.
- Wear eye protection while refueling.
- Never use gasoline as a cleaning agent.
- Store any containers containing gasoline in a well-ventilated area, away from any combustibles or source of ignition.
- Check for fuel leaks after refueling. Never operate the engine if a fuel leak is discovered.

WARNING



Never operate the inverter if powered items overheat, electrical output drops, there is sparking, flames or smoke coming from the inverter, or if the receptacles are damaged.



Never use the inverter to power medical support equipment.



Always remove any tools or other service equipment used during maintenance from the inverter before operating.

NOTICE

Never modify the inverter.

Never operate the inverter if it vibrates at high levels, if engine speed changes greatly or if the engine misfires often.

Always disconnect tools or appliances from the inverter before starting.

SAFETY

SAFETY LABELS AND DECALS MXR3500S

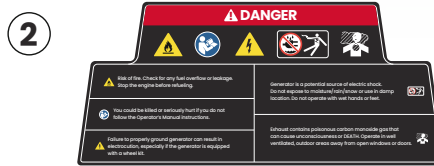

MAXPEEDINGRODS MXR3500S Inverter Generator	
Rated Power: 3.2kW - GAS	Rated Speed: 4600rpm
2.8kW - LPG	Power Factor: 1.0
Rated Voltage: 120V	Insulation Class: F
Rated Frequency: 60Hz	Rated Amb.Temp.: 25°C
Rated Current: 26.7A - GAS	DC Output: 5V 1A/2.1A
23.3A - LPG	Phase: Single
Chongqing Guoyu Technology Co., Ltd	

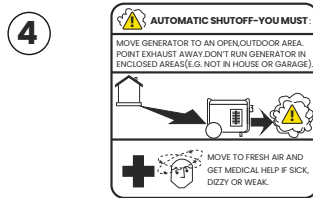

UNPACKING

CAUTION	
	Always have assistance when lifting the inverter. The inverter is heavy; lifting it could cause bodily harm.
	Avoid cutting on or near staples to prevent personal injury.

Tools required - box cutter or similar device.

- Carefully cut the packing tape on top of the carton.
- Remove socket wrench, funnel and save for later.
- Carefully cut two sides of the carton to remove the inverter.

WHAT COMES IN THE BOX

- Owner Manual (1)
- Spark Plug Socket Wrench (1)
- Oil Funnel (1)
- US Plug (2)
- Generator Parallel Cables (1)
- Screwdriver (1)
- Generator Dust Cover (1)
- Pressure Relief Valve Kit (1)
- Remote Controller (1)

FEATURES

BASIC INVERTER FEATURES MXR3500S



- ① **Fuel Cap:** Open the fuel tank cap and fill with proper amount of gasoline.
- ② **Control Panel:** Contains the reset breaker, outlets and warning lights.
- ③ **Muffler and Spark Arrestor:** Avoid contact until the engine is cooled down. The spark arrestor prevents sparks from exiting the muffler. It must be removed for servicing.
- ④ **Recoil Handle:** Pull to start the engine.

- ⑤ **Recoil Handle Protective Cover:** Prevents pull cord wire from damaging inverter body.
- ⑥ **Engine Service Panel:** Remove the panel to access the engine for maintenance.
- ⑦ **Engine Cooling Vents:** Helps move airflow in unit to regulate engine temperatures.

FEATURES

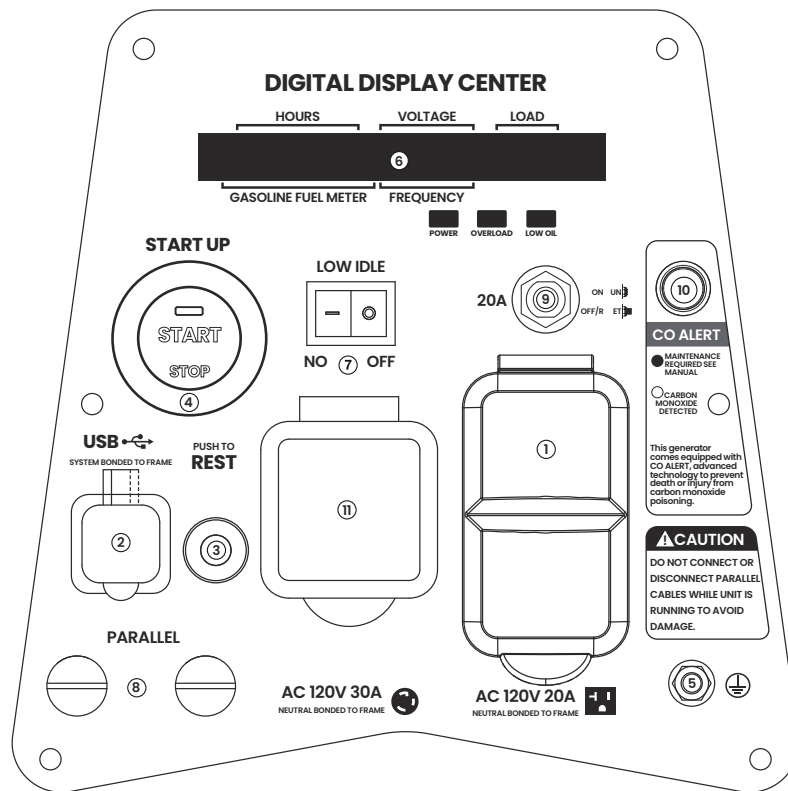

CONTROL RANEL FEATURES MXR3500S

- ① **120-Volt, 20-AMP Duplex Outlet (NEMA 5-20R):** The outlet is capable of carrying a maximum of 20 amps.
- ② **USB Duplex:** 5V DC that come in 1 amps and 2.1 amps.
- ③ **AC Reset:** If the inverter is overloaded, the reset breaker will trip. The engine will continue to run, but there will be no output from the inverter. Unplug the devices and reduce the load. Push in the reset breaker to reset it.
- ④ **One Push Start:** Press this button, the engine can start and stop Press this button for 3-5 seconds until the green light is on, and then press the ON/OFF button on the remote control key until the light is off. At this time, the remote control matches successfully.
- ⑤ **Ground Terminal:** The ground terminal is used to externally ground the inverter.
- ⑥ **Multifunctional LED Digital Display Meter:** Red light (LOW OIL) means that the amount of oil is too low, red light (OVERLOAD) means that the machine overload, green light (POWER) means normal operation. LED Digital Display shows time, voltage, power, frequency and fuel level; Time: scrolling display of single running time and accumulated running time.
- ⑦ **Efficiency Mode Switch:** When turned to the ON position, the engine will sense the load needed and run at a slower RPM to save fuel.
- ⑧ **Parallel Connectors:** To increase AC power output, the connector sockets are used to connect the two same type generator with special paralleling cords. The connector sockets is only used to the communication between the inverters. they can not used for AC power output. The special paralleling cords shall be purchase separately, and they shall be approved by certification body.
- ⑨ **AC Protector:** If the inverter is overload, the AC protector will trip to block current.
- ⑩ **CO Alarm:** Flashing red light: dangerous levels of carbon monoxide gas have built up leave immediately until area has aired out. Move generator to well-ventilated area before operation. Flashing yellow light: carbon monoxide sensor malfunction, sensor needs service.
- ⑪ **120-Volt, 30-AMP Outlet (L5-30):** The outlet is capable of carrying a maximum of 30 amps.

OPERATION

BEFORE STARTING THE INVERTER



BEFORE STARTING THE INVERTER, REVIEW SAFETY SECTION STARTING ON PAGE 5.

Location Selection – Before starting the inverter, avoid exhaust and location hazards by verifying:

- You have selected a location to operate the inverter that is outdoors and well ventilated.
- You have selected a location with a level and solid surface on which to place the inverter.
- You have selected a location that is at least 6 feet (1.8 m) away from any building, other equipment or combustible material.
- If the inverter is located close to a building, make sure it is not located near any windows, doors and/ or vents.

DANGER

Using a generator indoors **CAN KILL YOU IN MINUTES.**

Generator exhaust contains carbon monoxide. This is a poison you cannot see or smell.



NEVER use inside a home or garage, **EVEN IF** doors and windows are open.



Only use **OUTSIDE** and far away from windows, doors, and vents.

Avoid other generator hazards. **READ MANUAL BEFORE USE.**

WARNING



Always operate the inverter on a level surface. Placing the inverter on non level surfaces can cause the inverter to tip over, causing fuel and oil to spill. Spilled fuel can ignite if it comes in contact with an ignition source such as a very hot surface.

NOTICE

Only operate the inverter on a solid, level surface. Operating the inverter on a surface with loose material such as sand or grass clippings can cause debris to be ingested by the inverter that could:

- Block cooling vents
- Block air intake system

Weather – Never operate your inverter outdoors during rain, snow or any combination of weather conditions that could lead to moisture collecting on, in or around the generator.

Dry Surface – Always operate the inverter on a dry surface free of any moisture.

No Connected Loads – Make sure the inverter has no connected loads before starting it. To ensure there are no connected loads, unplug any electrical extension cords that are plugged into the control panel receptacles.

NOTICE

Starting the inverter with loads already applied to it could result in damage to any appliance being powered off the inverter during the brief start-up period.

Grounding the Inverters

There is a permanent conductor between the portable generator stator winding and the frame.

Consult with your local municipalities for your grounding codes.

WARNING



Be sure the inverter is properly connected to earth ground before operating.

Carbon Monoxide Specification

CO DETECT technology monitors the accumulation of carbon monoxide (CO), a poisonous gas produced by engine exhaust when the generator is running. If CO Sensor detects unsafe elevated levels of CO gas, it automatically shuts off the engine. CO Sensor is not a substitute for an indoor carbon monoxide alarm or for safe operation. DO NOT allow engine exhaust fumes to enter a confined area through windows, doors, vents or other openings. Generators must ALWAYS be used outdoors, far away from occupied buildings with engine exhaust pointed away from people and buildings. Meets the requirements of ANSI / PGMA G300-2018.

OPERATION

POWERCORD

Using Extension Cords

MAXPEEDINGRODS Portable Power assumes no responsibility for the content within this table. The use of this table is the responsibility of the user only. This table is intended for reference only. The results produced by using this table are not guaranteed to be correct or applicable in all situations as the type and construction of cords are highly variable. Always check with local regulations and a licensed electrician prior to installing or connecting an electrical appliance.

Extension Cord Wire Gauge Size

AMPS	LENGTH OF EXTENSION CORD (ft)								
	10	20	30	40	50	60	80	100	120
5	20	18	16	14	12	12	10	10	8
10	18	16	14	12	12	10	10	8	8
15	16	14	12	12	10	10	8	8	6
20	14	12	12	10	10	8	8	6	6
25	12	12	10	10	8	8	6	6	6
30	12	10	10	8	8	6	6	6	6
35	10	10	8	8	6	6	6	6	6

INVERTER PARALLELING OPERATION

 **DANGER**



Never connect the paralleling cord to the inverters with the inverters running. The inverters must not be running and both the paralleling cord switches must be off when connecting the cords.

 **WARNING**



Do not attempt to parallel the MAXPEEDINGRODS inverter with any other manufacturers' inverters. Do not use the paralleling cord for any application other than inverter paralleling. Do not use this cord on other manufacturers' inverters.



Always ensure that both ends of the paralleling cord are switched off before connecting the inverters.

INVERTER PARALLELING OPERATION

1. Using only the MAXPEEDINGRODS paralleling cord with both cord switches set to OFF (O), connect one male plug to one inverter and connect the remaining plug into the other inverter. Either of the receptacles on the inverters can be used.
2. Start one of the inverters and wait until the output ready light is on.
3. Turn both cord switches to ON (I).
4. Start the remaining inverter; wait until the output ready light is on before connecting the load.
5. When power is present, a light will illuminate in the three-prong plug that is plugged into the inverter.
6. To stop the inverters, unplug all connected loads, turn both cord switches to OFF (O) and unplug the cord on each inverter.
7. If during operation the inverters' output is stopped due to overloading, reduce the connected load by unplugging appliances, and then push the reset button and restart the inverter. When the ready light is on, the load can be reconnected.

OPERATION

INITIAL OIL FILL



BEFORE ADDING ENGINE OIL, REVIEW SAFETY SECTION STARTING ON PAGE 5.

NOTICE

Engine oil must be added when the inverter is on a flat, level surface, or an inaccurate reading may result. Do not overfill. If the engine is overfilled with oil, it can cause serious engine damage.

1. Loosen the knob on the right exterior cover and remove the right exterior cover (see Figure 1).

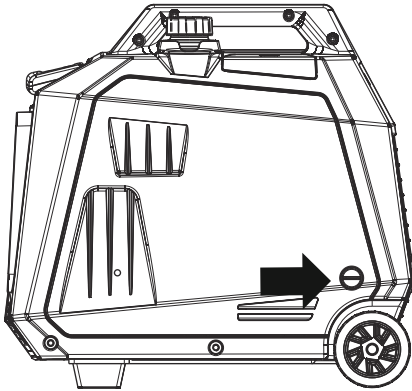

Figure 1: Engine Service Panel

2. Clean the area around the oil fill/drain plug and remove plug (See Figure 2).

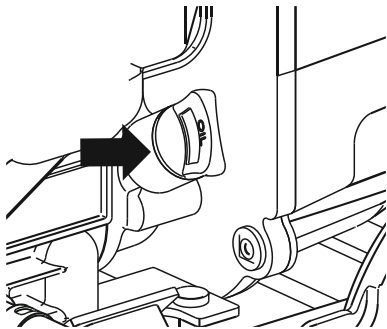

Figure 2: Oil Fill/Drain Plug

3. Using the funnel and oil, pour the entire bottle of oil into the engine (see Figure 3).

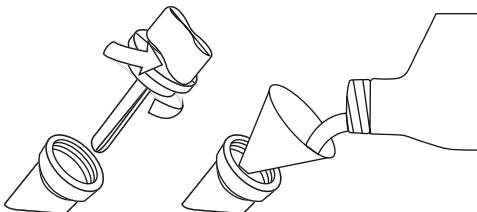

Figure 3: Oil Funnel

4. Do not overfill, if oil level is too high, oil will drain out through the fill plug. See correct oil level in Figure 4.

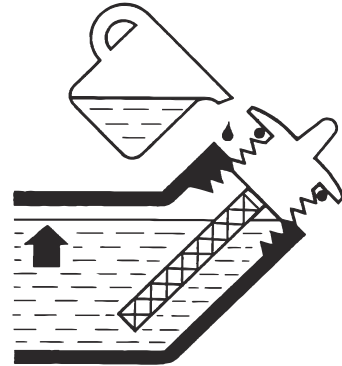

Figure 4: Engine Oil Correct Level

CONNECT THE BATTERY LINE

NOTICE

1. For the first use, open the side panel and connect the battery line.
2. Disconnect the battery line if long storage is required.
3. The generator is equipped with a battery charging feature. Once the engine is running, will slowly recharge the battery.

Nominal Voltage: 12.8V. Rated Capacity: 1.6Ah

1. Open the side panel.
2. Verify that the rubber battery strap is firmly securing the battery in place. If loose, pull on the strap and hook it onto the mounting base.
3. A quick-connect battery plug is preinstalled on the battery. Remove the battery plug protective cover then connect the battery plug.

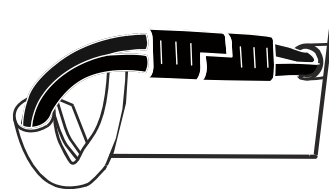

OPERATION

ADDING/CHECKING ENGINE FLUIDS AND FUEL



BEFORE ADDING/CHECKING ENGINE FLUIDS AND FUEL, REVIEW SAFETY SECTION STARTING ON PAGE 5.

DANGER



Filling the fuel tank with gasoline while the inverter is running can cause gasoline to leak and come in contact with hot surfaces that can ignite the gasoline.

Before starting the inverter, always check the level of:

- Engine oil
- Gasoline in the fuel tank

Once the inverter is started and the engine gets warm, it is not safe to add gasoline to the fuel tank or engine oil to the engine while the engine is running or the engine and muffler are hot.

CHECKING AND / OR ADDING ENGINE OIL

WARNING



Internal pressure can build in the engine crankcase while the engine is running. Removing the oil fill plug/dipstick while the engine is hot can cause extremely hot oil to spray out of the crankcase and can severely burn skin. Allow engine oil to cool for several minutes before removing the oil fill plug/dipstick.

The unit as shipped does not contain oil in the engine. You must add engine oil before starting the inverter for the first time. See Initial Oil Fill on page 12 for instructions on checking engine oil level and the procedure for adding engine oil.

NOTICE

The engine does not contain engine oil as shipped. Attempting to start the engine without adding engine oil will permanently damage internal engine components.

The engine is equipped with a low oil shutdown switch. If the oil level becomes low, the engine may shut down and not start until the oil is filled to the proper level.

The engine is equipped with a low oil shutdown switch. If the oil level becomes low, the engine may shut down and not start until the oil is filled to the proper level.

ADDING GASOLINE TO THE FUEL TANK

WARNING



Never refuel the inverter while the engine is running.



Always turn the engine off and allow the inverter to cool before refueling.

CAUTION



Avoid prolonged skin contact with gasoline. Avoid prolonged breathing of gasoline vapors.

Required Gasoline - Only use gasoline that meets the following requirements:

- Unleaded gasoline only
- Gasoline with maximum 10% ethanol added
- Gasoline with an 87 octane rating or higher

Filling the Fuel Tank - Follow the steps below to fill the fuel tank: (fuel tank capacity: 1.58Gal)

1. Shut off the inverter.
2. Allow the inverter to cool down so all surface areas of the muffler and engine are cool to the touch.
3. Move the inverter to a flat surface.
4. Clean area around the fuel cap.
5. Remove the fuel cap by rotating counterclockwise.

NOTICE

Do not overfill the fuel tank. Spilled fuel will damage some plastic parts.

6. Slowly add gasoline into the fuel tank. Be very careful not to overfill the tank. The gasoline level should NOT be higher than the red ring (see Figure 5).
7. Install the fuel cap by rotating clockwise.

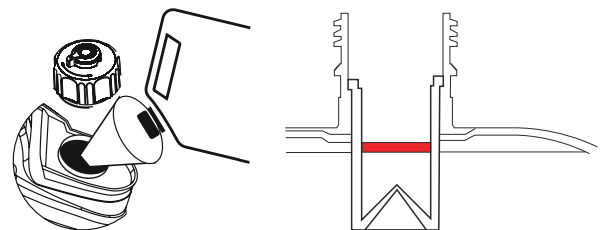

Figure 5: Maximum Gasoline Fill Level

OPERATION

STARTING THE INVERTER



BEFORE STARTING THE INVERTER, REVIEW SAFETY SECTION STARTING ON PAGE 5.

For proper starting and operation of the inverter, make sure you review the inverter features and their descriptions starting on page 8.

Before attempting to start the inverter, verify the following:

- The engine is filled with engine oil (see Figure 4: Engine Oil Correct Level on page 12).
- The inverter is situated in a proper location (see Location Selection on page 10).
- The inverter is on a dry surface (see Weather and Dry Surface on page 10).
- All loads are disconnected from the inverter (see No Connected Loads on page 10).
- The inverter is properly grounded (see Grounding the Inverter on page 10)

DANGER



Never use the inverter in a location that is wet or damp. Never expose the inverter to rain, snow, water spray or standing water while in use. Protect the inverter from all hazardous weather conditions. Moisture or ice can cause a short circuit or other malfunction in the electrical circuit.



Never operate the inverter in an enclosed area. Engine exhaust contains carbon monoxide. Only operate the inverter outside and away from windows, doors and vents.

Starting The Generator

1. Make certain the generator is on a flat, level surface.
2. Disconnect all electrical loads from the generator. Never start or stop the generator with electrical devices plugged in or turned on.
3. Select gasoline fuel

(1) Select gasoline fuel

The fuel selector is located on the left side of the front power panel. Flip the switch up to select gasoline as a fuel source.

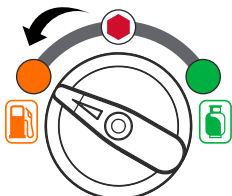

Figure 6

(2) Select LPG Fuel

- a. The fuel selector is located on the left side of the front power panel. Flip the switch down to select LPG as a fuel source.

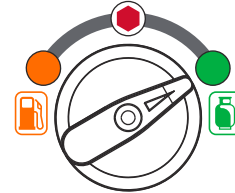

Figure 7

b. connect propane hose

The LPG inlet is located on the bottom left of the front panel. Connect the propane hose to both the inlet and the propane tank. Open the propane tank.

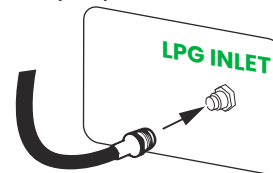

Figure 8

4. Before start the generator, turn low idle off.

LOW IDLE

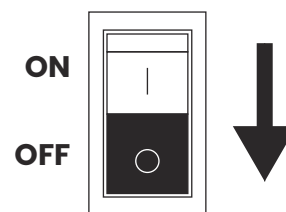

Figure 9

5. Choose the Starting Method

- (1) Recoil Start: Firmly grasp and pull the recoil handle slowly until you feel increased resistance, then pull rapidly.

Tip: When pulling the hand starter, hold the generator carrying handle firmly, to prevent the generator from overturning.

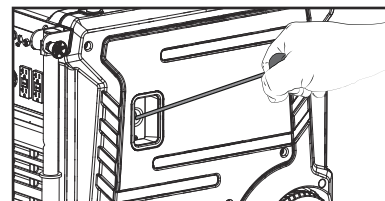

Figure 10

- (2) Push-Button Start: Press the start up button down for 1-3 seconds to start the generator.

OPERATION

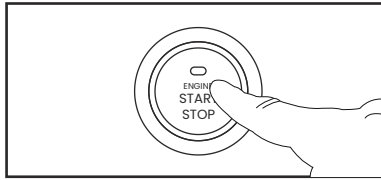

Figure 11

- (3) Remote Start: Push and hold the ON button on the remote start key fob for one second.

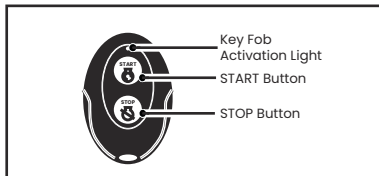

Figure 12

DANGER

Fire and explosion hazard. Always turn the propane tank valve to the fully closed position if not running the generator on propane.

WARNING

WHEN USING THE GENERATOR WITH LPG MAKE SURE THERE IS NO POSSIBLE IGNITION SOURCE CLOSE TO THE GENERATOR

1. Before using, make sure all of the LPG connectors and hoses are well connected and sealed.
2. Connect electrical devices to the generator ONLY after the engine runs smoothly. (There may be remnant gasoline in the carburetor; this can cause unsteady engine performance for several minutes).
3. If the propane gas leaks, shut off the LPG supply first and then quickly unplug or turn off any electrical devices powered by the unit.

Remote Control Pairing

1. Press the "START UP" button for 5 seconds, release it when the "START/MATCH" indicator lights up.
2. Before the "START UP" indicator light goes out, press "ON" on the remote control for 1 second, the "START/MATCH" indicator light goes out, this time the generator set starts.
3. Press "OFF" on the remote control for 1 second. the generator set shuts down, the remote control is paired successfully.

Tip: The remote control supplied with the generator has been paired successfully.

STOPPING THE INVERTER

Normal Operation

During normal operation, use the following steps to stop your inverter:

1. Remove all the loads out of the output.
2. Press "START UP" Button to stop the generator.
3. Turn the LPG/GAS switch to middle to turn off the fuel.

During an Emergency

To stop the engine in an emergency, please directly press "START UP" to stop the generator.

USING EFFICIENCY MODE

The inverter is equipped with an efficiency mode switch to minimize fuel consumption. In efficiency mode, the inverter will sense the load and adjust the engine RPM to the current load requirements. Efficiency mode should be used only after the inverter has been warmed up to operating temperature.

1. To turn on the efficiency mode, press the switch to the ON position).
2. If no load is present, the inverter RPM will drop down to an idle speed.
3. As a load is applied, the inverter will sense the load and engine RPM will increase according to the load applied.
4. To run the inverter at maximum power and RPM, press the efficiency mode switch to the OFF position.

RESETTING THE RESET BREAKER

The inverter will trip the breaker and automatically disconnect from the load when the controls sense a predetermined overload condition. The inverter engine will continue to run, but there will not be any electrical output.

1. Turn off all devices and unplug them from the inverter.
2. Determine the wattage required from the devices being powered by the inverter. Make sure the wattage required does not exceed the maximum output of the inverter.
3. Press in the reset breaker to reset it (see Figure 13).

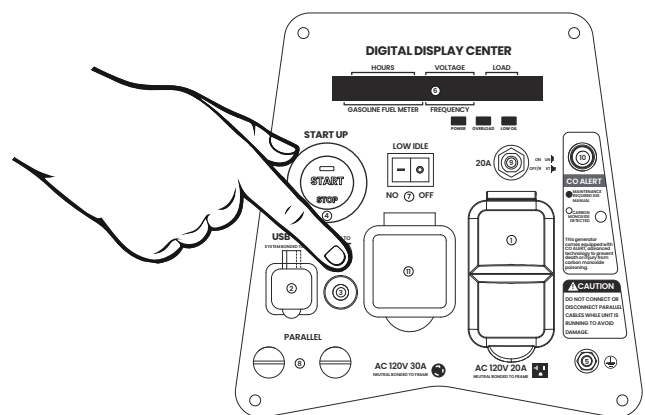

Figure 13: Press in reset breaker

4. Plug the devices in to the inverter.
5. Turn on the devices as needed.

MAINTENANCE



BEFORE PERFORMING MAINTENANCE ON THE INVERTER, REVIEW THE SAFETY SECTION STARTING ON PAGE 5, AS WELL AS THE FOLLOWING SAFETY MESSAGES.

⚠ WARNING	
	Avoid accidentally starting the inverter during maintenance by removing the spark plug boot from the spark plug. For electric start inverters, also disconnect the battery cables from the battery (disconnect the black negative (-) cable first) and place the cables away from the battery posts to avoid arcing.
	Allow hot components to cool to the touch prior to performing any maintenance procedure.
	Internal pressure can build in the engine crankcase while the engine is running. Removing the oil fill plug dipstick while the engine is hot can cause extremely hot oil to spray out of the crankcase and can severely burn skin. Allow engine oil to cool for several minutes before removing the oil fill plug/dipstick.
	Always perform maintenance in a well-ventilated area. Gasoline fuel and fuel vapors are extremely flammable and can ignite under certain conditions.

⚠ CAUTION	
	Avoid skin contact with engine oil or gasoline. Prolonged skin contact with engine oil or gasoline can be harmful. Frequent and prolonged contact with engine oil may cause skin cancer, take protective measures and wear protective clothing and equipment. Wash all exposed skin with soap and water.

⚠ WARNING	
	Failure to perform periodic maintenance or not following maintenance procedures can cause the inverter to malfunction and could result in death or serious injury.

NOTICE	
Periodic maintenance intervals vary depending on inverter operating conditions. Operating the inverter under severe conditions, such as sustained high-load, high-temperature, or unusually wet or dusty environments, will require more frequent periodic maintenance. The intervals listed in the maintenance schedule should be treated only as a general guideline.	

Following the maintenance schedule is important to keep the inverter in good operating condition. The following is a summary of maintenance items by periodic maintenance intervals.

TABLE 1: MAINTENANCE SCHEDULE – OWNER PERFORMED

Maintenance Item	Before Every Use	After First 20 Hours or First Month of Use	After 50 Hours of Use or Every 6 Months	After 100 Hour of Use or Every 6 Months	After 300 Hours of Use or Every Year
Engine Oil	Check Level	Change	Change	-	-
Cooling Features	Check/Clean	-	-	-	-
Air Filter	Check	-	Clean*	-	Replace
Spark Plug	-	-	-	Check/Clean	Replace
Spark Arrestor	-	-	-	Check/Clean	-

*Service more frequently if operating in dry and dusty conditions.

MAINTENANCE

ENGINE OIL MAINTENANCE

Engine Oil Specification

1. Only use the engine oil specified in Figure 14.
2. Only use 4-stroke/cycle engine oil. NEVER USE 2-STROKE/CYCLE OIL Synthetic oil is an acceptable substitute for conventional oil.

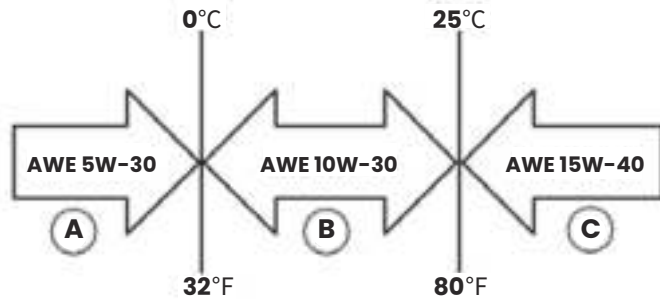

Figure 14 : Recommended Oil

CHECKING ENGINE OIL

NOTICE

Always maintain proper engine oil level. Failure to maintain proper engine oil level could result in severe damage to the engine and/or shorten the life of the engine.
Always use the specified engine oil. Failure to use the specified engine oil can cause accelerated wear and/ or shorten the life of the engine.

Engine oil level should be checked before every use.

1. Always operate or maintain the inverter on a flat surface.
2. Stop engine if running.
3. Let engine sit and cool for several minutes (allow crankcase pressure to equalize).
4. Remove the engine service panel to access the oil fill/drain plug.
5. With a damp rag, clean around the oil fill/drain plug.
6. Remove the oil fill/drain plug.
7. Check oil level: When checking the engine oil, remove the oil fill/ drain plug.
 - The oil level is acceptable if oil is visible at the bottom of the threads of the oil fill plug.
 - If oil level is low, add to the correct level using the supplied oil fill bottle. Do not overfill the oil crankcase.

NOTICE

Engine oil must always be checked and added when the inverter is on a flat, level surface, or an inaccurate reading may result, causing serious engine damage.

ADDING ENGINE OIL

1. Always operate or maintain the inverter on a flat surface.
2. Stop engine if running.
3. Let engine sit and cool for several minutes (allow crankcase pressure to equalize).
4. Remove the engine service panel to gain access to the oil fill/drain plug.
5. Thoroughly clean around the oil fill/drain plug.
6. Remove the oil fill/drain plug.
7. Select the proper engine oil as specified in Figure 14.
8. Using the supplied oil funnel, slowly add engine oil to the engine. Stop frequently to check the oil level and avoid overfilling.

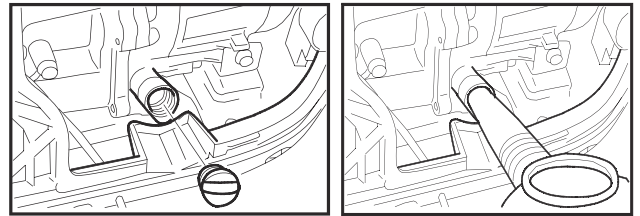

9. Continue to add oil until the oil is at the correct level.

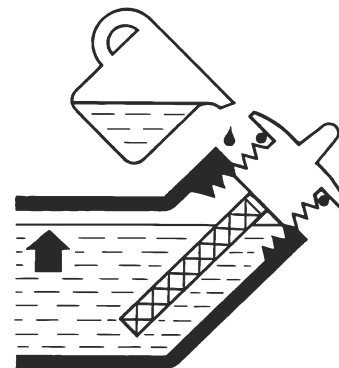

MAINTENANCE

CHANGING ENGINE OIL

Engine Oil Specification

1. Stop the engine.
2. Let engine sit and cool for several minutes (allow crankcase pressure to equalize).
3. Remove the engine service panel to gain access to the oil fill/drain plug.
4. Place oil pan (or suitable container) under the oil fill/ drain plug (see Figure 15).

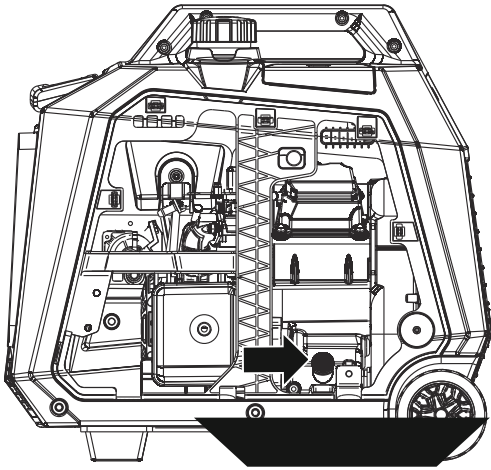

Figure 15: Place oil pan under oil fill/drain plug

5. With a damp rag, thoroughly clean around the oil fill/drain plug.
6. Tilt the inverter so the oil drains down the through into the container.

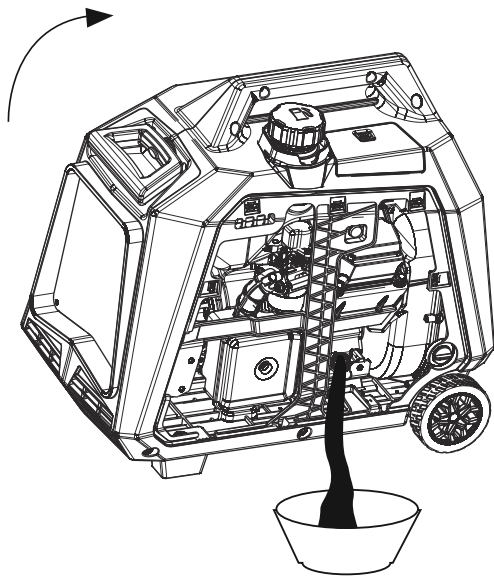

Figure 16: Carefully tip Inverter so oil flows into oil pan

7. Allow oil to completely drain.
8. Fill crankcase with oil following the steps outlined in Adding Engine Oil on page 16.
9. Dispose of used engine oil properly.

NOTICE

Never dispose of used engine oil by dumping the oil into a sewer, on the ground, or into groundwater or waterways. Always be environmentally responsible. Follow the guidelines or other governmental agencies for proper disposal of hazardous materials. Consult local authorities or reclamation facility.

AIR FILTER MAINTENANCE

WARNING



Never use gasoline or other flammable solvents to clean the air filter. Use only household detergent soap to clean the air filter.

Cleaning the Air Filter

The air filter must be cleaned after every 50 hours of use or 3 months (frequency should be increased if inverter is operated in a dusty environment).

1. Turn off the inverter and let it cool for several minutes if running.
2. Remove the engine service panel to gain access to the air filter.
3. Unscrew the air cleaner cover and tip the cover down (see Figure 17)
4. Remove the foam element from the air cleaner housing.

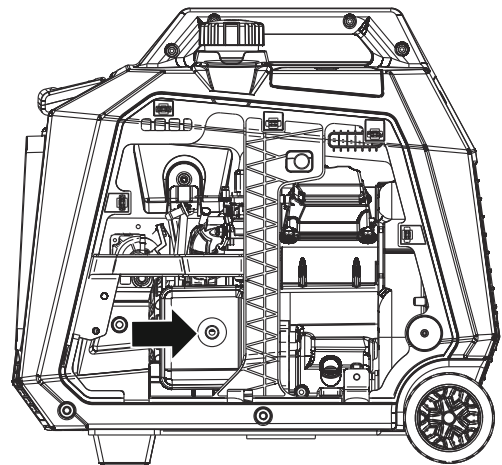

Figure 17: Unscrew air cleaner cover

MAINTENANCE

5. Wash the foam air filter element by submerging the element in a solution of household detergent soap and warm water. Slowly squeeze the foam to thoroughly clean.

NOTICE

NEVER twist or tear the foam air filter element during cleaning or drying. Only apply slow but firm squeezing action.

6. Rinse in clean water by submerging the air filter element in fresh water and applying a slow squeezing action (see Figure 18).



Figure 18

NOTICE

Never dispose of soap cleaning solution used to clean the air filter by dumping the solution into a sewer, on the ground, or into ground water or waterways. Always be environmentally responsible. Follow the guidelines or other governmental agencies for proper disposal of hazardous materials. Consult local authorities or reclamation facility.

7. Dispose of used soap cleaning solution properly.
8. Dry the air filter element by again applying a slow firm squeezing action.
9. Return the air filter element to its position in the air cleaner housing.
10. Install the air cleaner cover, making sure the tabs lock into place.
11. Install the engine service panel.

DRAINING THE FLOAT BOWL

1. Remove the engine service panel to access the carburetor.
2. Locate the clear plastic hose from the float that is exiting out the bottom of the inverter, and place a suitable container under it to catch the drained fuel (see Figure 19).

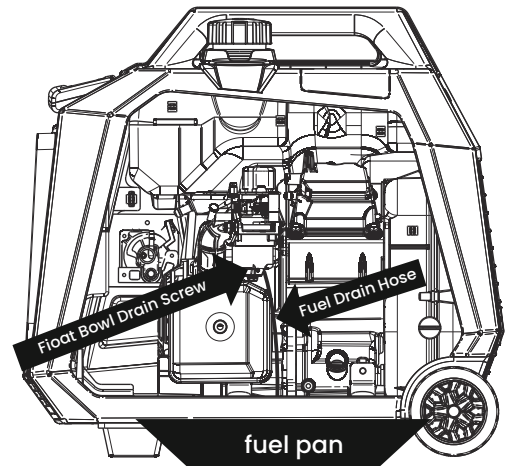

Figure 19: Fuel drain hose

3. Loosen the float bowl drain screw (see Figure 20) until fuel is seen draining from the float bowl.

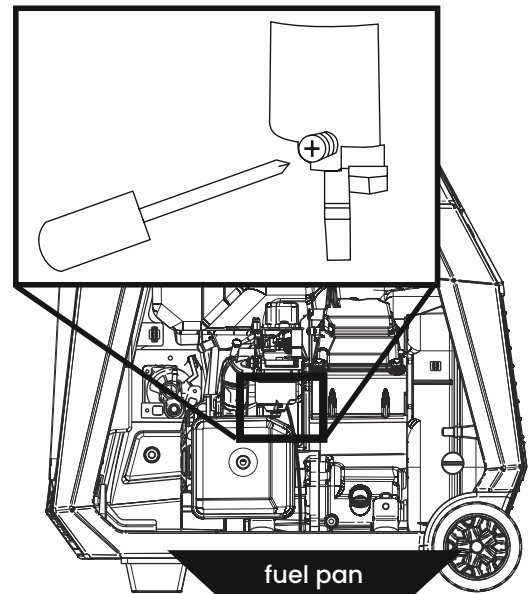

Figure 20: Loosen float bowl screw

4. Allow fuel to drain into the container, and then tighten the float bowl drain screw.

NOTICE

Never dispose of fuel by dumping fuel into a sewer, on the ground, or into groundwater or waterways. Always be environmentally responsible. Follow the guidelines or other governmental agencies for proper disposal of hazardous materials. Consult local authorities or reclamation facility.

5. Install the engine service panel.

MAINTENANCE

SPARK PLUG MAINTENANCE

The spark plug must be checked and cleaned after every 100 hours of use or 6 months and must be replaced after 300 hours of use or every year.

1. Stop the inverter and let it cool for several minutes if running.
2. Move the inverter to a flat, level surface.
3. Slide the spark plug access cover off the housing (see Figure 21).

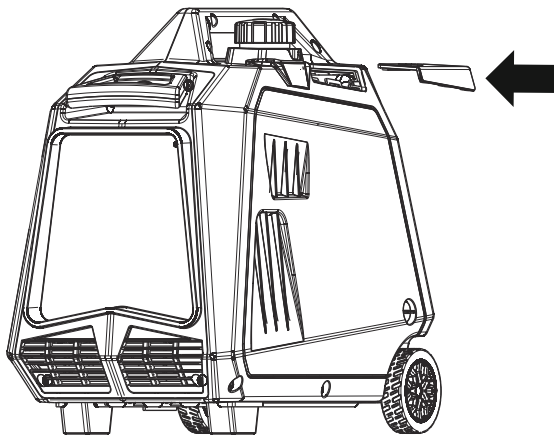

Figure 21: Slide off spark plug cover

4. Remove the spark plug boot by firmly pulling the plastic spark plug boot handle directly away from the engine.

NOTICE

Never apply any side load or move the spark plug laterally when removing the spark plug. Applying a side load or moving the spark plug laterally may crack and damage the spark plug boot.

5. Clean area around the spark plug.
6. Using the spark plug socket wrench provided, remove the spark plug from the cylinder head (see Figure 22).

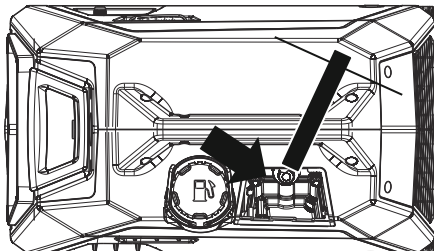
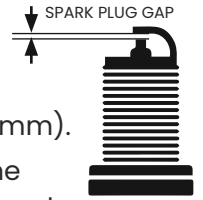

Figure 22: Slide off spark plug cover

7. Place a clean rag over the opening created by the removal of the spark plug to make sure no dirt can get into the combustion chamber.

8. Inspect the spark plug for:

- Cracked or chipped insulator
- Excessive wear
- Spark plug gap of 0.032 in. (0.80 mm).



If the spark plug fails any one of the conditions listed above, replace the plug.

NOTICE

Only use the recommended spark plug. See chart below. Using a non-recommended spark plug could result in damage to the engine.

9. Install the spark plug by carefully following the steps outlined below:
 - a. Carefully insert the spark plug back into the cylinder head. Hand-thread the spark plug until it bottoms out.
 - b. Using the spark plug socket wrench provided, turn the spark plug to ensure it is fully seated.
 - c. Replace the spark plug boot, making sure the boot fully engages the spark plug's tip.
 - d. Install the spark plug access cover

BRAND	TYPE
TORCH	A5RTC
NGK	CR7HS

MAINTENANCE

CLEANING THE SPARK ARRESTOR

Check and clean the spark arrestor after every 100 hours of use or 6 months.

1. Stop the inverter and let it cool for several minutes if running.
2. Move the inverter to a flat, level surface.
3. Remove the screws holding the muffler cover in place (see Figure 23).

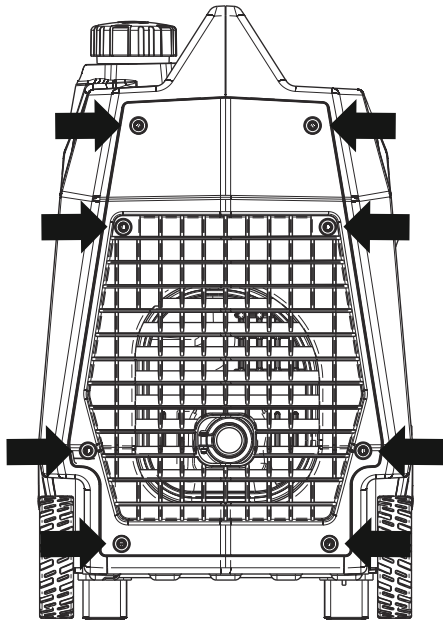

Figure 23: Remove screws holding muffler cover

4. Loosen the clamp holding the spark arrestor onto the muffler.
5. Slide the spark arrestor band clamp off the spark arrestor screen.
6. Pull the spark arrestor screen off the muffler exhaust pipe.
7. Using a wire brush, remove any dirt and debris that may have collected on the spark arrestor screen.
8. If the spark arrestor screen shows signs of wear (rips, tears or large openings in the screen), replace the spark arrestor screen.
9. Install the spark arrestor components in the following order:
 - a. Place spark arrestor screen over the muffler exhaust pipe. Push on the screen until it fully bottoms out.
 - b. Place the spark arrestor band clamp over the screen and tighten with a flathead screwdriver
10. Replace the discharge gate.

CLEANING THE INVERTER

It is important to inspect and clean the inverter before every use.

Clean All Engine Air Inlet and Outlet Ports – Make sure all engine air inlet and outlet ports are clean of any dirt and debris to ensure the engine does not run hot.

STORAGE

⚠ WARNING



Never store an inverter with fuel in the tank indoors or in a poorly ventilated area where the fumes can come in contact with an ignition source such as a: 1) pilot light of a stove, water heater, clothes dryer or any other gas appliance; or 2) spark from an electric appliance.

NOTICE

Gasoline stored for as little as 60 days can go bad, causing gum, varnish and corrosive buildup in fuel lines, fuel passages and the engine. This corrosive buildup restricts the flow of fuel, preventing an engine from starting after a prolonged storage period.

Proper care should be taken to prepare the inverter for any storage

1. Clean the inverter as outlined in Cleaning the Inverter.
2. Siphon all gasoline from the fuel tank as best as possible.
3. Start the engine and allow the inverter to run until all the remaining gasoline in the fuel lines and carburetor is consumed and the engine shuts off.
4. Drain any remaining fuel from the float bowl. See Draining the Float Bowl on page 19.
5. Change the oil (see Changing Engine Oil on page 18).
6. Remove the spark plug (see Spark Plug Maintenance on page 20) and place about 1 tablespoon of oil in the spark plug opening. While placing a clean rag over the spark plug opening, slowly pull the recoil handle to allow the engine to turn over several times. This will distribute the oil and protect the cylinder wall from corroding during storage.
7. Replace the spark plug (see Spark Plug Maintenance on page 20).
8. Move the inverter to a clean, dry place for storage.

TROUBLESHOOTING

⚠ WARNING



Before attempting to service or troubleshoot the generator, the owner or service technician must first read the owner's manual and understand and follow all safety instructions. Failure to follow all instructions may result in conditions that can lead to voiding certification or product warranty, serious personal injury, property damage or even death.

PROBLEM	POTENTIAL CAUSE	SOLUTION
Engine is running, but no electrical output.	1. Reset breaker is tripped.	1. Reset the reset breaker (see page 15).
	2. The power cord's plug connector is not fully engaged in the inverter's outlet.	2. Verify plug connector is firmly engaged in the inverter's outlet.
	3. Faulty or defective power cord.	3. Replace power cord.
	4. Faulty or defective electrical appliance.	4. Try connecting a known good appliance to verify the inverter is producing electrical power.
Engine will not start or remain running while trying to start.	1. Inverter is out of gasoline.	1. Add gasoline to the inverter (see page 13).
	2. Fuel flow is obstructed.	2. Inspect and clean fuel delivery passages.
	3. Dirty air filter.	3. Check and clean the air filter (see page 18).
	4. Low oil level shutdown switch is preventing the unit from starting.	4. Check oil level and add oil if necessary (see page 17).
	5. Spark plug boot is not fully engaged with the spark plug tip.	5. Firmly push down on the spark plug boot to ensure the boot is fully engaged.
	6. Spark plug is faulty.	6. Remove and check the spark plug. Replace if faulty (see pages 20).
	7. Dirty/plugged spark arrestor.	7. Check and clean the spark arrestor (see page 21).
	8. Stale fuel.	8. Drain fuel and replace with fresh fuel.
Inverter suddenly stops running.	1. Inverter is out of fuel.	1. Check fuel level (see page 13). Add fuel if necessary.
	2. The low oil shut down switch has stopped the engine.	2. Check oil level and add oil if necessary (see page 17).
	3. Too much load.	3. Restart the inverter and reduce the load.
Engine runs erratic; does not hold a steady RPM.	1. Choke was left in the CHOKE position.	1. Move choke to the RUN position.
	2. Dirty air filter.	2. Clean the air filter (see page 18).
	3. Applied loads maybe cycling on and off.	3. As applied loads cycle, changes in engine speed may occur; this is a normal condition.

MXR3500S SCHEMATICS

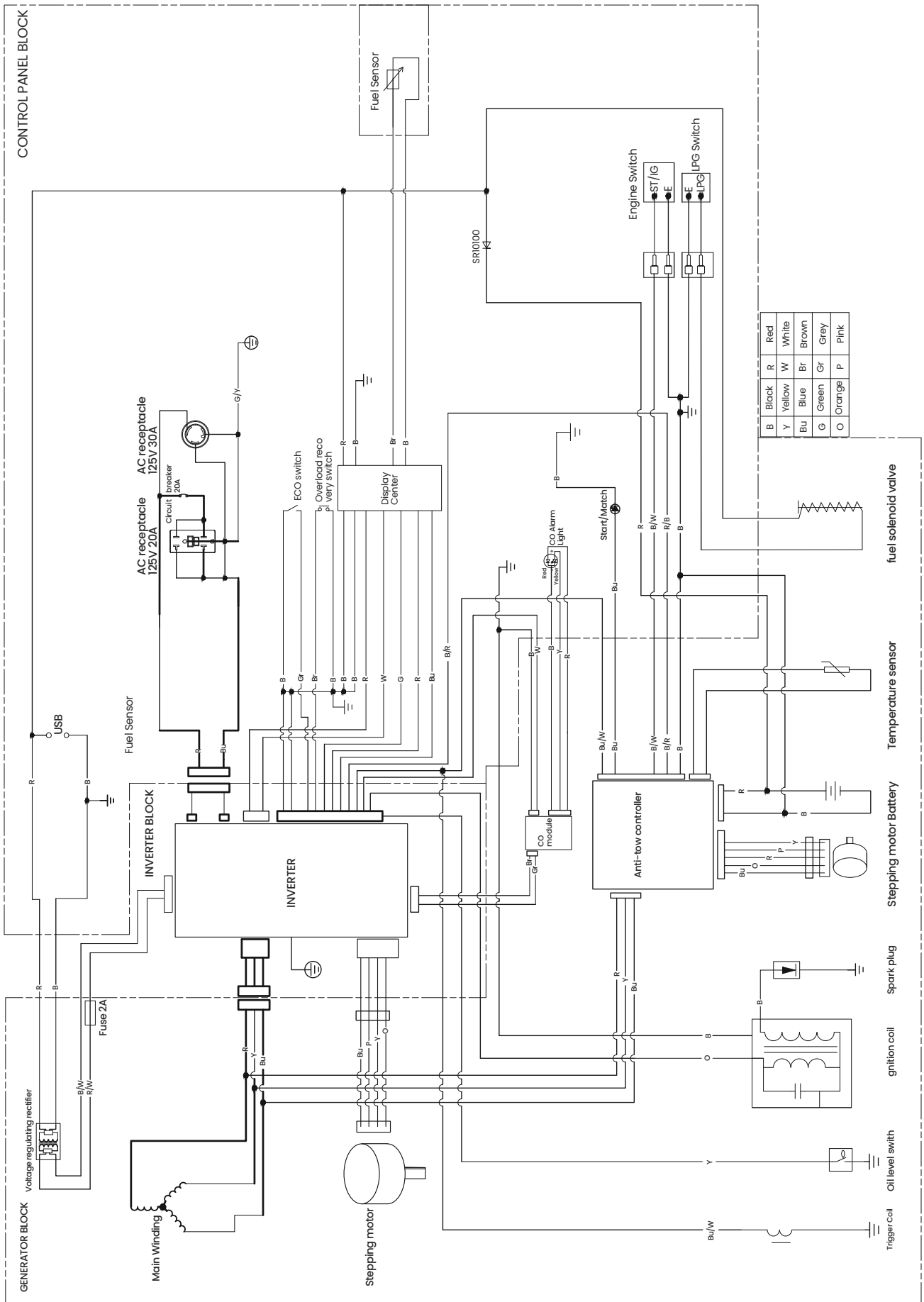

WARRANTY STATEMENT

Chongqing Guoyu Technology Co., Ltd warrants that the engine, including all parts of its emission control system, is designed, built, and equipped so it conforms at the time of sale to the ultimate purchaser with the requirements of 40 CFR Part 1054 and Part 1060, and it is free from defects in materials and workmanship that may keep it from meeting these requirements. The warranty period of the engine is two years beginning on the date of sale to the ultimate purchasers.

- I. For exhaust emissions, emission-related components include any engine parts related to the following systems
 1. Air-induction system.
 2. Fuel system.
 3. Ignition system.
 4. Exhaust gas recirculation systems.
- II. The following parts are also considered emission-related components for exhaust emissions:
 1. After-treatment devices.
 2. Crankcase ventilation valves.
 3. Sensors.
 4. Electronic control units.
- III. The following parts are also considered emission-related components for exhaust emissions:
 1. Fuel Tank.
 2. Fuel Cap.
 3. Fuel Line.
 4. Fuel Line Fittings.
 5. Clamps*.
 6. Pressure Relief Valves*.
 7. Control Valves*.
 8. Control Solenoids*.
 9. Electronic Controls*.
 10. Vacuum Control Diaphragms*.
 11. Control Cables*.
 12. Control Linkages*.
 13. Purge Valves.
 14. Vapor Hoses.
 15. Liquid/Vapor Separator.
 16. Carbon Canister
 17. Canister Mounting Brackets
 18. Carburetor Purge Port Connector

As related to the evaporative emission control system.

Emission-related components also include any other part whose only purpose is to reduce emissions or whose failure will increase emissions without significantly degrading engine/equipment performance. You may contact us by calling 1-866-577-4476, or sending e-mail to Lawrence@tomahawk-power.com. You may obtain the replacement components from the following address: 501 W Broadway Suite 2020 San Diego, CA 2101. Note: This warranty shall not apply if engine is subjected to other than normal and proper storage, handling, installation, operation and maintenance or to unauthorized repairs or alterations.

THE US EPA & CALIFORNIA AIR RESOURCES BOARD EMISSIONS CONTROL WARRANTY STATEMENT

YOUR WARRANTY RIGHTS AND OBLIGATIONS

The U.S. environmental protection agency(EPA), California air resources board and Chongqing Guoyu Technology Co., Ltd are pleased to explain the emissions control system's warranty on your 2022 model year small off-road engine. In California, new small off-road engines must be designed, built, and equipped to meet the state s stringent anti-smog standards. Chongqing Guoyu Technology Co., Ltd must warrant the emissions control system on your small off-road engine for the period listed below provided there has been no abuse, neglect or improper maintenance of your small off-road engine leading to the failure of the emission control system your emission control system may include parts such as: carburetors or fuel injection system, ignition system, catalytic converters, fuel tanks, fuel lines (for liquid and fuel vapors) fuel caps, valves canisters, filters, clamps, connectors, and other associated components. Also included may be hoses, belts, connectors, and other emission-related assemblies.

Where a warrantable condition exists, Chongqing Guoyu Technology Co., Ltd will repair your small off-road engine at no cost to you including diagnosis, parts and labor.

MANUFACTURER'S WARRANTY COVERAGE

This emissions control system is warranted for two years. If any emissions-related part on your small off-road engine is defective, the part will be repaired or replaced by Chongqing Guoyu Technology Co., Ltd.

OWNER'S WARRANTY RESPONSIBILITIES:

As the small off-road engine owner you are responsible for performance of the required maintenance listed in your owners manual Chongqing Guoyu Technology Co., Ltd recommends that you retain all receipts covering maintenance on your small off-road engine but Chongqing Guoyu Technology Co., Ltd cannot deny warranty coverage solely for the lack of receipts.

As the small off-road engine owner ou should be aware that Chongqing Guoyu Technology Co., Ltd may deny you warranty coverage if your small off-road engine or a part has failed due to abuse, neglect, or improper maintenance or unapproved modifications. You are responsible for presenting your small off-road engine to a Chongqing Guoyu Technology Co., Ltd distribution center or service center as soon as the problem exists . The warranty repairs shall be completed in a reasonable amount of time , not to exceed 30days . If you have a question regarding your warranty coverage , you should contact at1-866-577-4476 or email me to Lawrence@tomahawk-power.com.

DEFECTS WARRANTY REQUIREMNTS:

This emissions control system is warranted for two years. If any emissions-related part on your small off-road engine is defective, the part will be repaired or replaced by Chongqing Guoyu Technology Co., Ltd.

- (a)The warranty period begins on the date the engine or equipment is delivered to an ultimate purchaser.
- (b)General Emissions Warranty Coverage. The small off-road engine or equipment must be warranted to the ultimate purchaser and any subsequent owner the emission control system when installed was
 - (1) Designed, built, and equipped so as to conform with all applicable regulations adopted by the US EPA California Air Resources Board and
 - (2)Fee from defects in materials and workmanship that causes the failure of a warranted part for a period of two years.
- (c)The warranty on emissions-related parts will be interpreted as follows:
 - to the ultimate purchaser and any subsequent owner the emission control system when installed was

- (1) Any warranted parts not scheduled for placement as required maintenance in the written instructions required by subsection (e) must be warranted for the warranty period defined in Subsection (b) (2). If any such part fails during the period of warranty coverage, it must be repaired or replaced by Chongqing Guoyu Technology Co., Ltd according to Subsection (4) below. Any such part repaired or replaced under the warranty must be warranted for a time not less than the remaining warranty period.
 - (2) Any warranted part that is scheduled only for regular inspection in the written instructions required by subsection (e) must be warranted for the warranty period defined in Subsection (b) (2). A statement in such written instructions to the effect of repair or replace as necessary shall advise owners of the warranty coverage for evaporative emissions related parts. Replacement within the warranty period is covered by the warranty and will not reduce the period of warranty coverage. Any such part repaired or replaced under warranty must be warranted for a time not less than the remaining warranty period.
 - (3) Any warranted part that is scheduled for replacement as required maintenance in the written instructions required by subsection (e) must be warranted for the period of time prior to the first scheduled replacement point for that part. If the part fails prior to the first scheduled replacement, the part must be repaired or replaced by the engine manufacturer according to Subsection (4) below. Any such part repaired or replaced under warranty must be warranted for a time not less than the remainder of the period prior to the first scheduled replacement point for the part.
 - (4) Repair or replacement of any warranted part under the warranty provisions of this article must be performed at no charge to the owner at a warranty station.
 - (5) Notwithstanding the provisions of Subsection (4) above, Warranty services or repairs must be provided at all manufacturer distribution centers that are franchised to service the subject engines.
 - (6) The owner must not be charged for diagnostic labor that leads to the determination that a warranted part is in fact defective, provided that such diagnostic work is performed at a warranty station.
 - (7) Throughout the emissions control system's warranty period defined in Subsection (b) (2), Chongqing Guoyu Technology Co., Ltd must maintain a supply of warranted parts sufficient to meet the expected demand for such parts and must obtain additional parts if that supply is exhausted.
 - (8) Manufacturer-approved replacement parts that do not increase the exhaust or evaporative emissions of the engine or evaporative emission control system must be used in the performance of any warranty maintenance or repairs and must be provided without charge to the owner. Such use will not reduce the warranty obligations of Chongqing Guoyu Technology Co., Ltd.
 - (9) The use of add-on or modified parts may be grounds for disallowing a warranty claim made in accordance with this Article. Chongqing Guoyu Technology Co., Ltd will not be liable under this Article to warrant failures of warranted parts caused by the use of an add-on or modified part.
 - (10) Chongqing Guoyu Technology Co., Ltd shall provide any documents that describe that Chongqing Guoyu Technology Co., Ltd's warranty procedures or policies within five working days of request by the Executive Officer.
- (d) A list of all emission warranty parts list must be included with each new engine or equipment subject to this Article, The emission warranty parts list shall include all parts whose failure would increase exhaust and evaporative emissions, and may contain, but is not limited to, the following parts:
- (1) Fuel Metering System
 - Carburetor and internal parts (and / or pressure regulator or fuel injection system
 - Air / fuel ratio feedback and control system
 - Cold start enrichment system
 - Fuel Tank

- (2) Air Induction System
 - Controlled hot air intake system
 - Intake manifold
 - Air filter
- (3) Ignition System
 - Spark Plugs
 - Magneto or electronic ignition system
 - Spark advance / retard system
- (4) Air Injection System
 - Air pump or pulse valve
 - Valves affecting distribution of flow
 - Distribution manifold
- (5) Catalyst or Thermal Reactor System
 - Catalytic converter
 - Thermal reactor
 - Exhaust manifold
- (6) Particulate Controls
 - Traps, filters, precipitators, and any other device used to capture particulate emissions.
- (7) Miscellaneous Items Used in Above Systems (Electronic controls
 - Vacuum, temperature, and time sensitive valves and switches
 - Dhoses, belts, connectors, and assemblies.

Evaporative Emission Warranty Part Lis

- (1) Fuel Tank
- (2) Fuel Cal
- (3) Fuel lines (for liquid fuel and fuel vapors)
- (4) Fuel Line Fittings
- (5) Clamps
- (6) Pressure Relief Valves
- (7) Control Valves
- (8) Control Solenoids)
- (9) Electronic Controls
- (10) Vacuum Control Diaphragms
- (11) Control Cables
- (12) Control Linkages
- (13) Purge Valves
- (14) Gaskets
- (15) Liquid / Vapor Separator
- (16) Carbon Canister
- (17) Canister Mounting Brackets
- (18) Carburetor Purge Port Connector

Note: As they relate to the evaporative emission control system.

- (e) Written instructions for the maintenance and use of the evaporative emissions control system by the owner shall be furnished with each new engine or equipment subject to this Article. The instructions must be consistent with this Article and applicable regulations contained herein.

MAX SPEEDING RODS