

# Operating Instruction For Meat Slicer

Before use, please read this manual  
Please pay attention to safety and health



Thank you to select this company production of semi-automatic food slicing machine

This company produces the food slicing machine in comprehensive home and abroad the same kind product based on the advantage of, achieves the operation more convenient, use more safety.

## 1. Note

The power must be complied with electric requirements on the label rating,it will cause the serious trouble of the fire or the machine if improperly use.

The machine must be earthed when using,it is dangerous to get an electric shock if not ground or not reliable to grounded.

Please turn off all switch and unplug when Emergency happen.

The hand or other part of body not allowed to enter work space when the machine open ,or will hurt you.

The machine should be repaired by manufacturer or agent if it does not work.

We are not Responsible for hurting or requirement hurt as self amending machine.

When the electric wire damage,must instead of it.

The electric wire must be used special soft wire,buy it from manufacturer or repair department.

The machine can not be wash by water,the machine is not the waterproof structure,it will cause get an electric shock and damage the mechanical department and electric parts.

Please turn off all switches when not operate and unplug.

Please stop operate and unplug when workman clean the machine.

Must to stop the machine operate when find the machine operate unusually.

Often to check the blade-cover,table loading meat,slicer and other parts whether tight or damage.

Can not cut the frozen meat below the temperature of -6°C.

Please attach the manual operation when resell the machine.

Please contact us when damage or lose the manual operation.

Please contact us when you meet other items which not detail in the manual operation.

# The safety sign



The machine before operation must be reliable grounding, avoid the leakage accident personal accident.



The machine operation, it is strictly prohibited to a finger into the work area, avoid cut off your fingers.



In the machine and cleaning replacement blade, finger may not touch the blade edge, lest stabbing fingers.

## 2、 Main Technical Specifications

Model	Voltage	Power (W)	Slice Thickness (mm)	Blade Diameter (mm)	Max slicing width	Weight	Measurement
JK-195	220-240V/50Hz/60Hz110V/60Hz	120W	0.2-12MM	195MM	160MM	14KG	520*420*380MM
JK-220JS	220-240V/50Hz/60Hz110V/60Hz	120w	0.2-12MM	220MM	160MM	14.5KG	520*420*380MM
JK-220A	220-240V/50Hz/60Hz110V/60Hz	120W	0.2-12MM	220MM	160MM	17KG	575*465*415MM
JK-220						18KG	
JK-220L						19KG	
JK-250A	220-240V/50Hz/60Hz 110V/60Hz	150W	0.2-12MM	250MM	160MM	18KG	575*465*415MM
JK-250						19KG	
JK-250L						20KG	
JK-275A	220-240V/50Hz/60Hz 110V/60Hz	250W	0.2-15MM	275MM	200MM	25KG	615*525*500MM
JK-275						26KG	
JK-275L						28KG	
JK-300A	220-240V/50Hz/60Hz 110V/60Hz	250W	0.2-15MM	300MM	220MM	27KG	615*525*500MM
JK-300						28KG	
JK-300L						30KG	

### 3、 Machine instruction and parts name

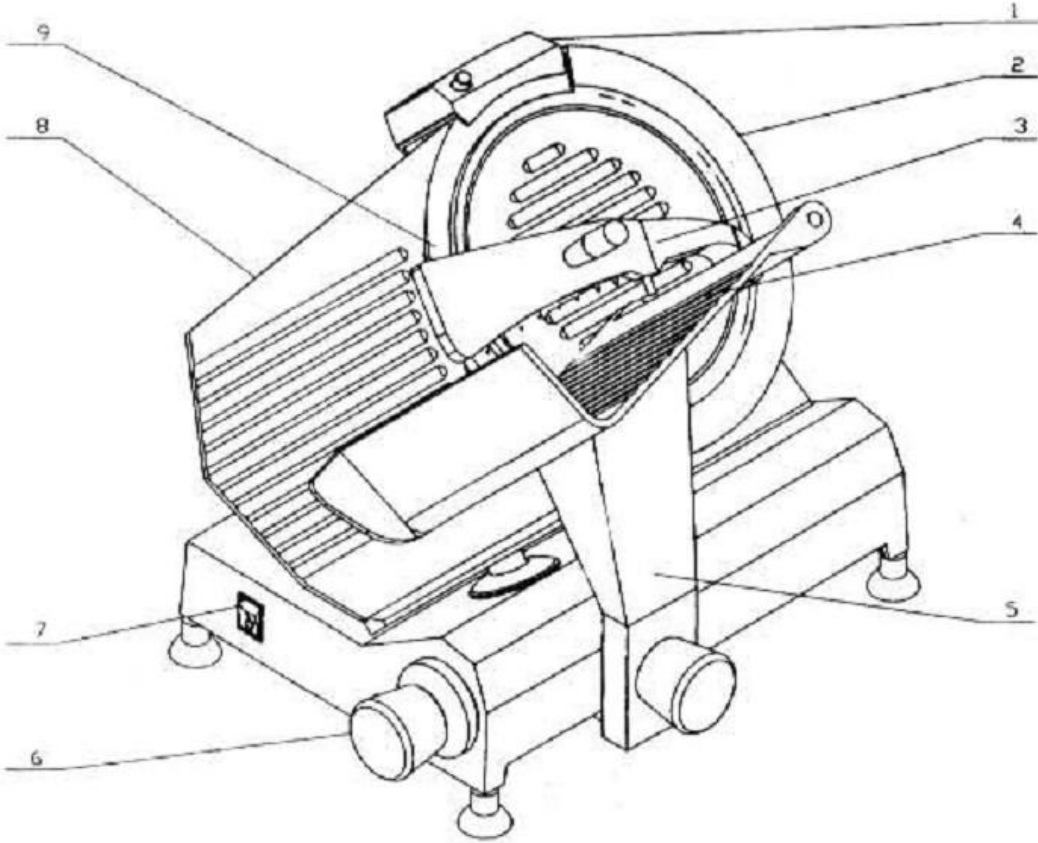

1.Sharpener

4.Carriage

7.Power button

2.Guard cutter

5.Product pusher handle

8.Scale plate

3. Active pusher

6.Slicer thickness regulator

9.Slicer

## 4、 Operation

1. The machine should be installed on a work surface that has sufficient stability and strength to support the weight of machine.
2. Make sure that the line voltage of your main power source matches the rated voltage of the machine.
3. Turn the switch on and let the machine race about 2-3 minutes look if the machine works well.
4. Turn the swith on,the polit lamp of the power button is lighting,and the lade rotate on the opposite way of watch hands.
5. Adjust the slicer thickness by turning the slicer thickness regulator on the opposite way of watch hands.Turn the fixing positioner knob in the way of watch hands.
6. Pushing the product carriage forward and back over the blade with a continuous motion,using the product pusher handle and the push knob.
7. After slicing the desired amount of the zero position.Turn the fixing positioner knob and let the fixing positioner head back to the original position.
8. You can now move away the slicers and the products.

## 5、 Cleaning

1. Always turn off and unplug the machine before cleaning,and make sure to turn the slicer thickness regulator to zero position.
2. Never use any chemical or abrasive products.Do not use a brush or any other type of utensils instrument,which could damage the different piece of the slicers.
3. Use a damp cloth in detergent to clean the machine,thin and dry.Make sure to clean the machine completely everyday.
4. Removing the blade cover away from the blade when cleaning,and clean the products carriage,too.
5. Warning for blade cleaning:
  - a. wear a safety glove for making the operation
  - b. do not touch the edge of the blade.
  - c. this is a dangerous operation,be careful.

## 6、 Maintenance

### 1. Blade rustproof

- a. Dry the blade with fry cloth after work.
- b. Spread the cooking oil on the edge of the blade with dry cloth.
- c. Sharp the blade everyday to prevent rust.

### 2. Guide lubrication:

- a. Push the carriage to one side, and clean the grease dirt of the guide with dry cloth.
- b. Smear the guide surface with grease by figure, well spread and lubricate.
- c. It is suitable to lubricate the guide every week.

### 3. Pusher axle lubrication

- a. Clean the pusher with dry cloth first.
- b. Put the cooking oil on the both of the axles.
- c. It is suitable to lubricate the axle every week.

### 4. Localizing head lubrication

- a. Turn the fixing positioner on the opposite way of watch hands to the max length.
- b. Clean the localizing head and put the cooking oil on.
- c. Turn around and slide the axle until the axles work well.

### 5. Localizing head lubrication:

- a. Turn the fixing positioner on the opposite way of watch hands to the max length.
- b. Clean the localizing head and put the cooking oil on.
- c. Then the fixing positioner back to the original position.
- d. It is suitable to lubricate it every week and do not spread too much oil.

## 7、 Blade Sharpening

- 1.You ought to sharpen the blade when the slicer thickness not even or the slicers broken not piece.
- 2.Clean the edge of the blade before sharpening
- 3.Pull the sharpener out and lubricate the sharpener axles as it works well.
- 4.Pull the sharpener out and turn 180° ,press the right side stone down by finger the put the sharpener to the working position.
- 5.Make sure that the surface of stone is nesting closely to the surface of edge.If not,please adjust it.
- 6.Turn the power on and the blade work 1-2 minutes,stop the machine,look if the blade is sharpened well,if not,continuous.
- 7.Press the left side stone down and make sure the surface of stone is nesting closely to the surface of blade,then sharpen 3 seconds to remove the burr.
- 8.Put the sharpener back to the original position after work.
- 9.Always keep the stone clean as the stone works well.
- 10.Do not make your eyes look right to the way that the stone rotate in order to the hurt from the piece of the stone.

## ILLUSTRATION

