

12V DC ELECTRIC WINCH

INSTRUCTIONS

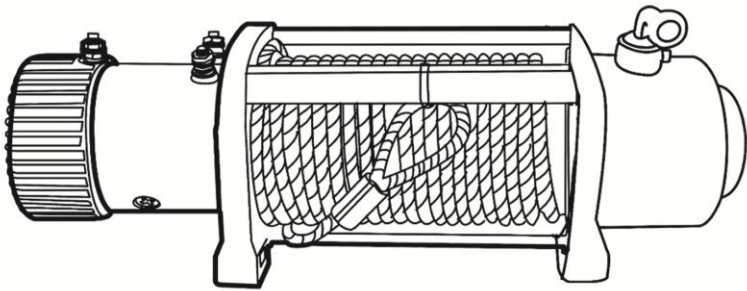

⚠ WARNING: Read carefully and understand all ASSEMBLY AND OPERATION INSTRUCTIONS before operating. Failure to follow the safety rules and other basic safety precautions may result in serious personal injury.

SAVE THESE INSTRUCTIONS

SAFETY PRECAUTIONS

Warning! Observe safety precautions for personal safety and the safety of others. Improper equipment operation may cause personal injury and equipment damage.

Read the following carefully before attempting to operate your winch and keep the instructions for future reference.

1. Dress Properly:

- Don't wear loose clothing or jewelry. They can be caught in moving parts.

- Wear leather gloves when handling winch cable. Do not handle cable with bare hands broken wires can cause injuries.

- Non-skid footwear is recommended,

- Protective hair covering to contain long hair.

2. Keep a Safe Distance:

- Ensure that all persons stand well clear of winch cable and load during winch operation, 1.5 times the cable length recommended. If a cable pulls loose or breaks under load it can lash back and cause serious personal injury or death.

- Don't step over the cable.

- All visitors and onlookers should be kept away from the work area.

- Keep proper footing and balance at all times.

3. Don't Abuse the Cord:

- Never carry your winch by the cord or yank it to disconnect it from the receptacle.

- Keep cord from heat, oil and sharp edges.

4. Don't Overwork the winch:

- If the motor becomes uncomfortably hot to touch, stop and let it cool for a few minutes.

- Don't maintain power to the winch if the motor stalls.

- Don't exceed maximum line pull ratings shown in tables. Shock loads

must not exceed these ratings.

5. Avoid Unintentional Starting:

-Winch clutch should be disengaged when not in use and fully engaged when in use.

6. Check Damaged Parts:

-Before using, you should check your winch carefully. Any part that is damaged should be properly repaired or replaced by an authorized service centre.

7. Repair Your Winch:

-When repairing, use only identical replacement parts or it may cause considerable danger for the user.

8. Respool the Cable:

-Leather gloves must be worn while respolling. To respool correctly, it is necessary to keep a slight load on the cable. Hold the cable with one hand and the remote control switch with the other. Start as far back and in the centre as you can. Walk up keeping load on the cable as the winch is powered in.

-Do not allow the cable to slop through your hand and do not approach the winch too closely.

-Turn off the winch and repeat the procedure until all the cable except 1m is in.

-Disconnect the remote control switch and finish spooling in cable by rotating the drum by hand with clutch disengaged.

-On hidden winches, spool in cable under power but keep hands clear.

Warning: The use of any other accessory or attachment other than those recommended in the instruction manual may present a risk of personal injury.

WINCH OPERATION WARNINGS

Read the following carefully before attempting to operate your winch and keep the instructions for future reference.

1. The uneven spooling of cable, while pulling a load, is not a problem, unless there is a cable pile up on one end of the drum. If this happens reverse the winch to relieve the load and move your anchor point further to the centre of the vehicle.

After the job is done you can unspool and rewind for a neat lay of the cable.

2. Store the remote control switch inside your vehicle where it will not become damaged, inspect it before you plug it in.

3. When ready to begin spooling in, plug in remote control switch with clutch disengaged, do not engage clutch with motor running.

4. Never connect the hook back to the cable. This causes cable damage. Always use a sling or chain of suitable strength.

5. Observe your winch while winching, if possible while standing at a safe distance. Stop the winching process every meter or so to assure the cable is not pulling up in one corner. Jamming the cable can break your winch.

6. Do not attach tow hooks to winch mounting apparatus. They must be attached to vehicle frame.

7. The use of a snatch block will aid recovery operations by providing a doubling of the winch capacity and a halving of the winching speed, and the means to maintain a direct line pull to the centre of the fairlead. When double loading during stationary winching, the winch hook should be attached to the chassis of the vehicle.

8. Ensure rated "D" or bow shackles are used in conjunction with an approved tree trunk protector to provide a safe anchor point.

9. When extending winch cable, ensure that at least five wraps of cable remain on drum at all times. Failure to do this could result in the cable parting from the drum under load . Serious personal injury or property damage may result.

10. All winches are provided with a red cable marking to identify that 5 cable wraps remain on the Winch drum when this mark appears at the fairlead. No recovery should be attempted beyond this marking.

11. Since the greatest pulling power is achieved on the innermost layer of your winch, it is desirable to pull off as much line as you can for heavy pulls (you must leave at least 5 wraps minimum on the drum-red cable). If this is not practical use a snatch block and double line arrangement.

12. Draping a heavy blanket or similar object over the extended winch cable is recommended as it will dampen any back lash should a failure occur.

13. Neat, tight spooling avoids cable binding, which is caused when a load is applied and the cable is pinched between the others. If this happens, alternatively power the winch in and out. Do not attempt to work a bound cable under load, free by hand.

14. Apply blocks to wheels when vehicles are on an incline.

15. Battery:

- Be sure that the battery is in good condition. Avoid contact with battery acid or other contaminants.

- Always wear eye protection when working around a battery.

- Have the engine running when using the winch, to avoid flattening the battery.

16. Winch Cable:

- Be sure that the cable is in good condition and is attached properly.

- Do not use the winch if cable is frayed.

- Do not move the vehicle to pull a load.

- The life of the cable is directly related to the use and care it receives.

Following its first and subsequent uses, a cable must be wound on to the drum under a load of at least 500lbs (230kg) or the outer wraps will draw into the inner wraps and severely damage the cable during winching. The first winch use should be a familiarization run while in a relaxed, non-recovery situation. Spool out the cable until the red cable appears (about five wraps on the drum), then rewind the cable on to the drum under a load

of 500lbs (230kg) or more. This will slightly tension and stretch the new cable and create a tight cable wrap around the drum. Failure to do so may result in cable damage and reduced cable life.

- Prevent kinks before they occur.

(a) This is the start of a kink. At this time, the wire rope should be straightened.

(b) The wire rope was pulled and the loop has tightened to a kink. The wire rope is now permanently damaged and should not be used.

(c) The result of kinking is that each strand pulls a different amount causing the strands under greatest tension to break and reduce load capacity of the wire rope.

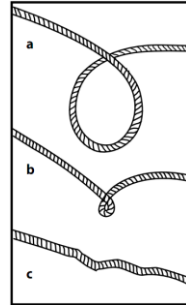

- When the cable is replaced, be sure to apply Lactate, or an equal compound, to the cable clamp thread. Tighten the clamp screw properly but do not over tighten. The lactate will prevent loosening of the screw in arduous conditions.

Lactate 7471 Primer and 222 Thread locker are recommended.

17. Do not attempt to exceed the pulling limits of this winch.

Maximum working load capacity is on the wire rope layer closest to the drum. **DO NOT OVERLOAD. DO NOT ATTEMPT PROLONGED PULLS AT HEAVY LOADS.** Overloads can damage the winch and/or the wire rope and create unsafe operating conditions. **FOR LOADS OVER 1/2 RATED CAPACITY, WE RECOMMEND THE USE OF THE OPTIONAL PULLY BLOCK TO DOUBLE LINE THE WIRE ROPE.** This reduces the load on the winch and the strain on the wire rope approximately 50%. Attach hook to load bearing part. The vehicle engine should be running during winch operation. If considerable winching is performed with the engine off, the battery may be too weak to restart the engine.

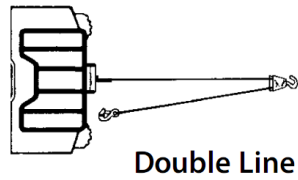
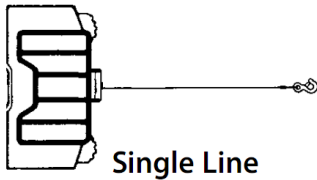

18. AFTER READING AND UNDERSTANDING THIS MANUAL, LEARN TO USE YOUR WINCH. After installing the winch, practice using it so you will be familiar with it when the need arises.

19. DO NOT “move” your vehicle to assist the winch in pulling the load. The combination of the winch and vehicle pulling together could overload the wire rope and the winch.

20. ALWAYS STAND CLEAR OF WIRE ROPE, HOOK AND WINCH. IN THE UNLIKELY EVENT OF ANY COMPONENT FAILURE IT’S BEST TO BE OUT OF HARM’S WAY.

21. Inspect wire rope and equipment frequently. A frayed wire rope with broken strands should be replaced immediately.

22. Use heavy leather gloves when handling wire rope. Do not let wire rope slide through your hands.

23. Never winch with less than 5 turns of wire rope around the winch drum since the wire rope end fastener may NOT withstand full load.

24. Never put your finger through the hook. If your finger should become trapped in the hook, you could lose your finger.

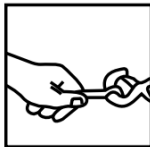

25.ALWAYS USE THE HAND SAVER When guiding the wire rope in or out.(See Figure 2).

26. Do not use winch in hoisting applications due to required hoist safety factors and features.

27. Do not use the winch to lift, support or otherwise transport people.

INSTALLATION

MOUNTING YOUR WINCH

1. a) The winch is to be mounted into a suitable steel mounting frame using the 4 point foot mounting system in either a horizontal or vertical plane.
 - b) It's very important that the winch be mounted on a flat surface so that the three sections (motor, cable drum and gear housing) are properly aligned.
 - c) Before commencing installation ensure the mounting facility being used is capable of withstanding the winches rated capacity.
 - d) The fitment of winches and/or a frontal protection system may affect the triggering of SRS air bags. Check that the mounting system has been tested and approved for winch fitment in the airbag equipped vehicle.
2. Winch mounting frames and /or Frontal Protection Systems are suggested to suit most popular vehicles. Winch frames are packaged with detailed fitting instructions.
 3. Should you wish to manufacture your own mounting plate the dimensions below will assist. A steel mount plate 6mm thick is recommended. Fasteners should be steel high tensile grade 5 or better. A poorly designed mount may void warranty.
 4. The winch should be secured to the mounting with 3/8"UNC x 1-1/4"stainless steel bolts and spring washers provided.
 5. The fairlead is to be mounted so as to guide the cable onto the drum evenly.

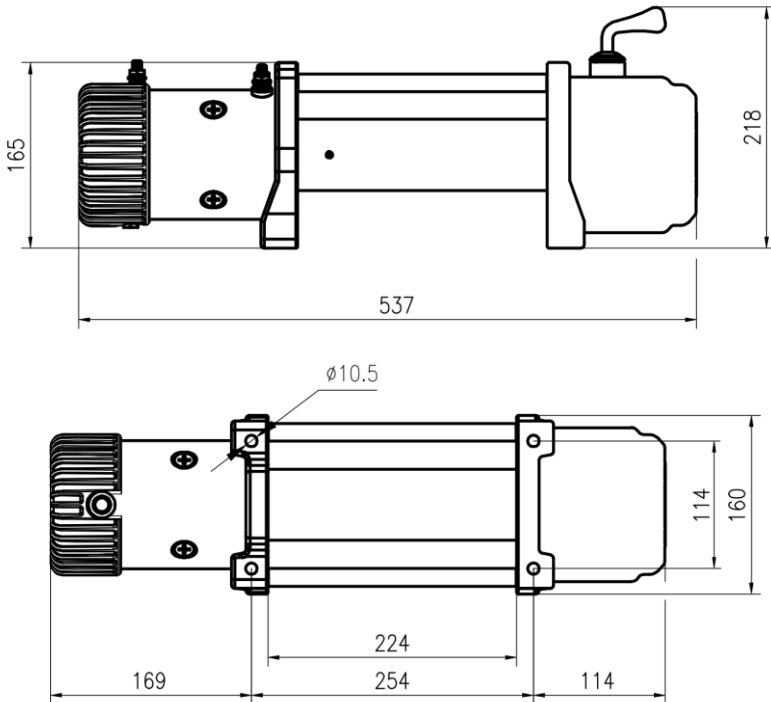

LUBRICATION INSTALLATION

All moving parts in the winch are permanently lubricated with high temperature lithium grease at the time of assembly. Under normal conditions factory lubrication will suffice. Lubricate cable periodically using light penetrating oil. Inspect for broken strands and replace if necessary. If the cable becomes worn or damaged it must be replaced.

CABLE INSTALLATION

Unwind the new cable by rolling it along the ground, to prevent kinking. Removed old cable and observe the manner in which it is attached to the drum flange.

MOUNTING WINCH

WARNING
Always choose a mounting location that is sufficiently strong to withstand the maximum pulling capacity of your winch.

WARNING
Always complete the winch installation and attach the hook before installing the wiring.

WARNING
Never use bolts that are too long.

MOUNTING WINCH

Choose a mounting location that is sufficiently strong enough to withstand the loads you intend to winch. Only the mounting orientations shown are possible for safe winching operation. All others are improper and inappropriate. The use of recommended bolt and lock washer combinations torqued to recommended levels will prevent vibration during operation. The mounting details indicate the proper torque levels.

Remember the winch rope must always spool onto the drum as indicated by the drum rotation decal.

Refer to the following diagrams for proper mounting orientation.

Control Pack Installation

Mount the control pack according to the instructions included in the mounting system kit. Use the bracket included in the kit. To mount the control pack directly to the winch.

The control pack mounting fasteners may also be moved to the unused holes in the control pack base plate for additional mounting flexibility.

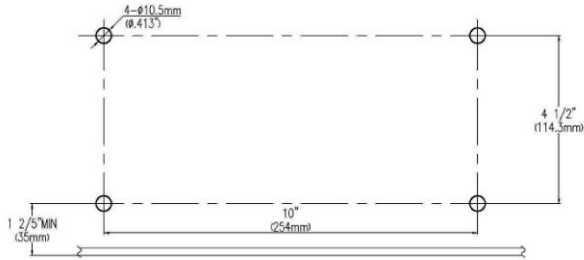

Mounting Details:

- (1) Mounting plate (1PC) <Please note the mounting plate is not included>
- (2) Hex bolt M10X30 (4PCS)
- (3) Spring washer Φ 10 (6PCS)
- (4) Gasket Φ 10 (6PCS)
- (5) Hex nut M10 (2PCS)
- (6) Square nut M10 (4PCS)
- (2) Hex bolt M10X25 (2PCS)
- (7) 4-way roller fairlead (1PC)

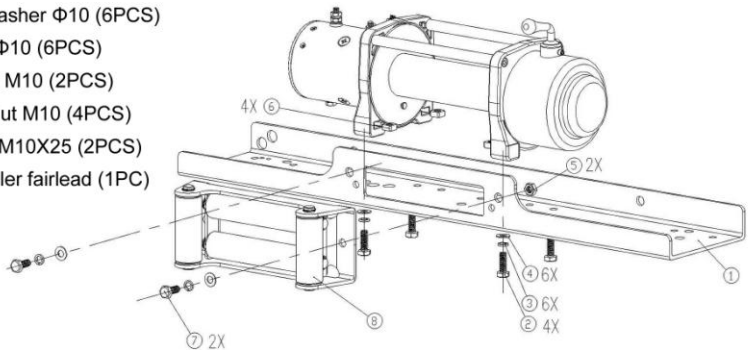

ELECTRICAL CONNECTION

For normal self -recovery work, your existing electrical system is adequate. A fully charged battery and proper connections are essential. Run the vehicle engine during winching operations to keep battery charged.

Pay close attention to proper electrical cable connection as follows (refer to Diagram1)

1. Short red cable (B') connecting to the red terminal (B) of the motor.
2. Short black cable with yellow jacket (C') connecting to the yellow terminal (C) of the motor.
3. Short black cable with black jacket (D') connecting to the black terminal (D) of the motor.
4. Thin black cable (a') connecting to bottom terminal (A) of the motor.
5. Long black cable (1.8m), one terminal (A') connecting to the bottom terminal (A) of the motor, and the other terminal negative (-) connecting to negative (-) terminal of battery.
6. Long red cable positive (+) connecting to positive (+) terminal of battery.

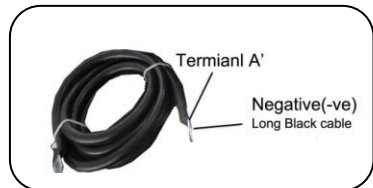
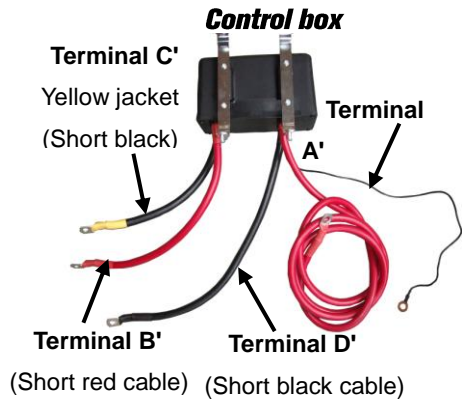
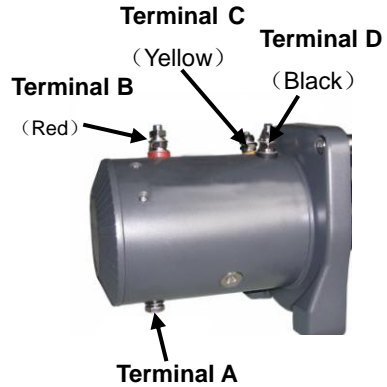

NOTE:

1. Your battery must be kept in good condition.
2. Be sure battery cables are not drawn taught across any surfaces, which could possibly damage them.
3. Corrosion on electrical connections will reduce performance or may cause a short.
4. Clean all connections especially in remote control switch and receptacle.
5. In salty environments use a silicone sealer to protect from corrosion.
6. **DO NOT ATTEMPT TO INSTALL WIRING WHEN THE BATTERY IS CONNECTED.** Automotive batteries contain flammable and explosive gases. Wear eye protection during installation and remove all metal jewelry. Do not lean over battery while making connections.

WINCH OPERATION**SUGGESTION:**

The best way to get acquainted with how your winch operates is to make a few test runs before you actually need to use it .Plan your test in advance. Remember you can hear your winch as well as you can see it operate. Get to recognize the sound of a light steady pull, a heavy pull, and sounds caused by load jerking or shifting. Soon you will gain confidence in operating your winch and its use will become second nature to you.

OPERATING:

1. Ensure the vehicle is secure by applying the parking brake or chocking the wheels.
2. Pull out the winch cable the desired length and connect to an anchor point.

The winch clutch allows rapid uncoiling of the cable for hooking onto the load or anchor point. The shifter tab located on the gear housing of the winch operates the clutch as follows:

- a) To disengage the clutch, move the clutch shifter tab to the "FREESPOOL" position. Cable could be free spooled off the drum.
- b) To engage the clutch, move the clutch shifter tab into the "ENGAGED" position. The winch is now ready for pulling.

FREESPOOL:



ENGAGED:



3. Recheck all cable rigging before proceeding .
4. Plug in the winch hand control. It is recommended that the winching operation takes place from the driver's position to ensure safe operation.
5. To commence winching operation, start vehicle engine, select neutral in transmission, maintain engine speed at idle.
6. Operate the hand control or the wireless remote control until the vehicle has been retrieved. Regularly check the winch to ensure cable is winding onto the drum evenly.

Note:

1. Never winch with your vehicle in gear or in park, which would damage your vehicle's transmission.
2. Never wrap the cable around the object and hook onto the cable itself. This can cause damage to the object being pulled, and kink or fray the cable.
3. Keep hands, clothing, hair and jewelry clear of the drum area and cable when winching.
4. Never use the winch if the cable is frayed, kinked or damaged.
5. Never allow anyone to stand near the cable or in line with the cable behind the winch while it is under power. If the cable should slip or brake, it can

suddenly whip back towards the winch, causing a hazard for anyone in the area. Always stand well to the side while winding.

6. Don't leave the switch plugged in when winch is not in use.

CHECK THE WINCH CAREFULLY AND THOROUGHLY BEFORE OPERATING!

MAINTENANCE

It is highly recommended that the winch be used regularly (once a month). Simply power the cable out 15m, free spool 5m and then power back in. This will keep all components in good working condition so that the winch can be relied on when needed. Contact your authorized outlet for technical assistance and repairs.

SPARE PARTS:

A comprehensive range of spare parts is available.

Please kindly contact the distributor or the local retailer.

WINCHING CAPACITY

1. Pulling capacity is reduced as the incline increases.
2. Winch is not intended as a load securing device.

NOTE:

This winch must be mounted with the wire rope in the underwound direction.

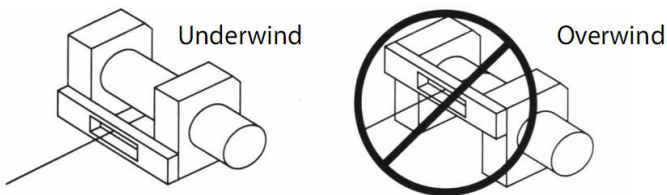

NOTE:

The safety precautions and instructions discussed in this manual can't cover all possible conditions and situations that may occur. It must be understood by the operator that common sense and caution are factors, which cannot be built into this product, but must be applied by the operator.



TO use hand remote, plug in. When you finish your recovery, remove from control box. Never leave your remotes in the control box when not in use.

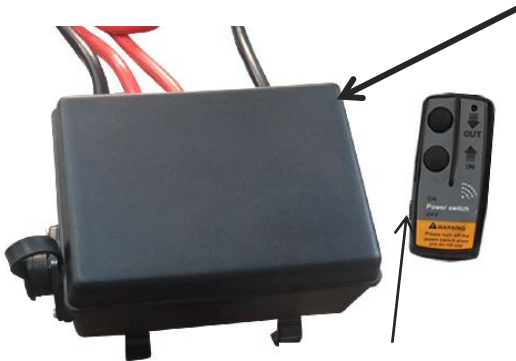

To use wireless remote, turn on the power button on the side of the transmitter, then press IN and OUT. Turn the power button off when operation is over.

POWER BUTTON

WINCH PARTS LIST

| Item No. | Description | Qty |
|----------|-------------------------------------|-----|
| 1 | Hexagon screw | 1 |
| 2 | Spring washer | 1 |
| 3 | Clutch handle | 1 |
| 4 | Nut cap | 1 |
| 5 | Cup gasket | 1 |
| 6 | Spring washer | 1 |
| 7 | O-ring | 2 |
| 8 | Gear box housing | 1 |
| 9 | shaft sleeve | 1 |
| 10 | sun gear | 1 |
| 11 | 3 rd Planetary gear assy | 1 |
| 12 | Dual inner gear | 1 |
| 13 | 2nd Planetary gear assy | 1 |
| 14 | 1st Planetary gear assy | 1 |
| 15 | Sealing washer | 1 |
| 16 | Hexagon screw | 4 |
| 17 | Spring washer | 4 |

| Item No. | Description | Qty |
|----------|---|-----|
| 18 | Gear box bracket | 1 |
| 19 | Spring washer | 10 |
| 20 | Hexagon screw | 10 |
| 21 | Bearing bush | 2 |
| 22 | Sealing washer | 2 |
| 23 | Durm assembly | 1 |
| 24 | Brake assembly | 1 |
| 25 | Tie bar | 2 |
| 26 | Motor assembly | 1 |
| 27 | Cross Recess Head Screw | 4 |
| 28 | Mounting bracket assembly for control box | 2 |
| 29 | Control box assembly | 1 |
| 30 | Fairlead | 1 |
| 31 | 3/8" Hook | 1 |
| 32 | Wired remote control | 1 |
| 33 | Battery negative (-) cord 1.8M | 1 |
| 34 | Wireless remote receiver | 1 |

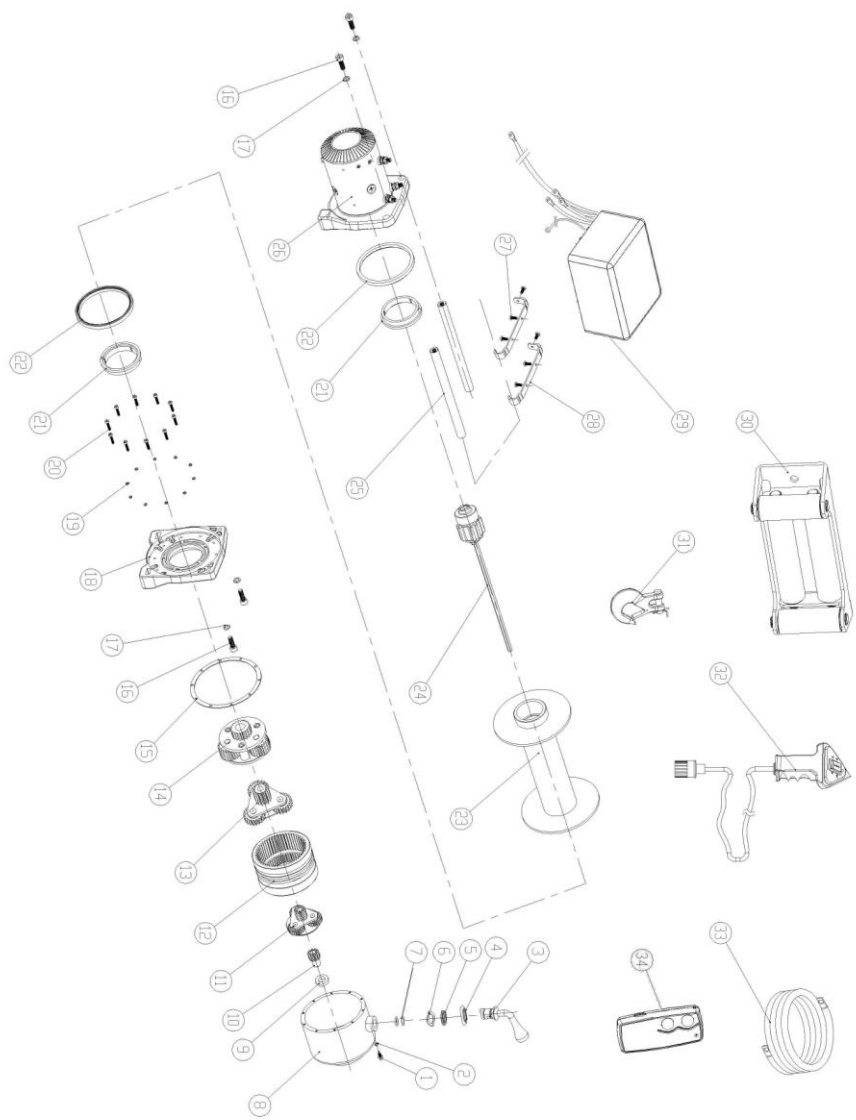

WINCH PARTS LIST

| Item No. | Description | Qty |
|----------|-------------------------------------|-----|
| 1 | Hexagon screw | 1 |
| 2 | Spring washer | 1 |
| 3 | Clutch handle | 1 |
| 4 | Nut cap | 1 |
| 5 | Cup gasket | 1 |
| 6 | Spring washer | 1 |
| 7 | O-ring | 2 |
| 8 | Gear box housing | 1 |
| 9 | shaft sleeve | 1 |
| 10 | sun gear | 1 |
| 11 | 3 rd Planetary gear assy | 1 |
| 12 | Dual inner gear | 1 |
| 13 | 2nd Planetary gear assy | 1 |
| 14 | 1st Planetary gear assy | 1 |
| 15 | Sealing washer | 1 |
| 16 | Hexagon screw | 4 |
| 17 | Spring washer | 4 |

| Item No. | Description | Qty |
|----------|---|-----|
| 18 | Gear box bracket | 1 |
| 19 | Spring washer | 10 |
| 20 | Hexagon screw | 10 |
| 21 | Bearing bush | 2 |
| 22 | Sealing washer | 2 |
| 23 | Durm assembly | 1 |
| 24 | Brake assembly | 1 |
| 25 | Tie bar | 2 |
| 26 | Motor assembly | 1 |
| 27 | Cross Recess Head Screw | 4 |
| 28 | Mounting bracket assembly for control box | 2 |
| 29 | Control box assembly | 1 |
| 30 | Fairlead | 1 |
| 31 | 3/8" Hook | 1 |
| 32 | Wired remote control | 1 |
| 33 | Battery negative (-) cord 1.8M | 1 |
| 34 | Wireless remote receiver | 1 |

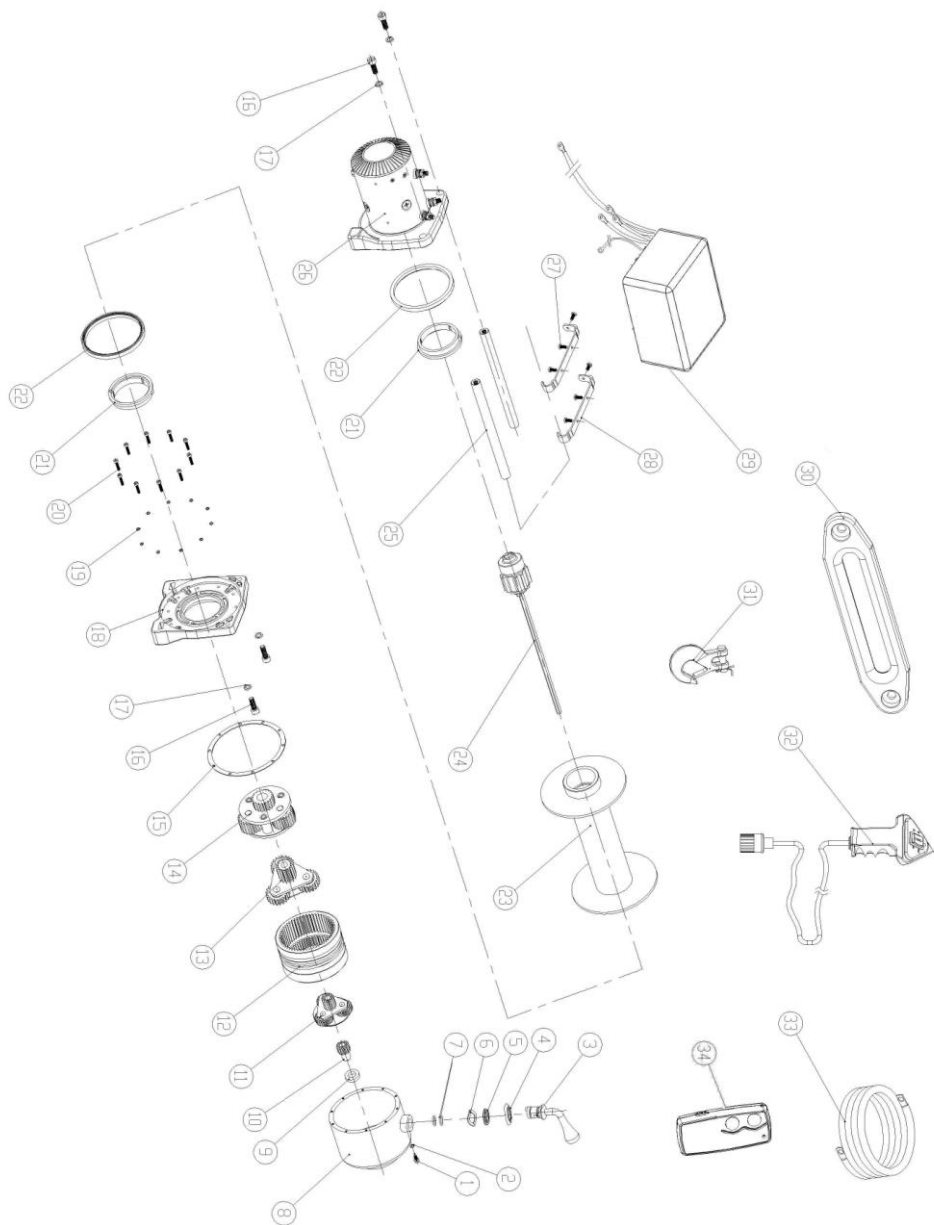

Maintenance

- Inspect all electrical components frequently to ensure clean and secure connections.
- This item is exposed to the elements; moisture can accumulate inside the winch when exposed to rain, pressure cleaners, steam cleaning, river crossings and the common car wash. To prevent corrosion it is best practice to use the winch once a month as a minimum even if to unwind a few metres and wind back in, the heat generated will help to dissipate any condensation.
- Regularly check all bolts and fittings are tight and secure, these could work loose under hard working conditions
- Under normal conditions the winch should not require servicing. If you use the winch regularly you should consider a servicing schedule to maximise the life and performance of the winch
- If the winch is fully submersed in water please ensure it is serviced at the next appropriate interval before storage.
Ensure winch motor is clean and dry, renew grease in gear box and other internals using a quality bearing type grease.
- Check the winch cable before use for any signs of wear, if wear signs are apparent replace before use.
- Wind cable neatly on the drum, after each use of the winch the cable should be unspooled to the point of where the cable lays neatly on the drum and respoiled under load.

TROUBLE SHOOTING CHECK LIST

WINCH DOES NOT OPERATE UNDER NORMAL CONDITIONS

- Vehicle battery should be in good working order and fully charged.
- Check that all wiring is correct as per the diagrams in this manual.
- Check that all electrical connections and cables are in good condition, free from corrosion and connected properly.
- Check to see if there is power getting to the motor from the battery.
- Earth power cable should be connected directly to the earth terminal on the battery not the vehicle chassis.
- Only the power cables supplied with this winch should be used, any other cable may not be of a high enough specification to supply sufficient power to the winch.
- Check that the hand control switch is not damaged and functioning properly.
- Check the battery in wireless remote controller.
- Check that the control box socket is in good condition.

WINCH WORKS IN WRONG DIRECTION

- Check that the cable is spooled in right direction on the drum.
- Ensure all wiring is correct as per the diagrams in this manual.

WINCH MOTOR GETS TOO HOT

- Winch should only be operated in 50 second duty cycles and allowed to cool.
- Check that all electrical connections and cables are in good condition, free from corrosion and connected properly.
- Only the power cables supplied with this winch should be used, any other cable may not be of high enough specification to supply sufficient power to the winch.

WINCH OPERATES SLOWLY:

- Vehicle battery should be in good working order and fully charged, vehicles charging system should be supplying good charge to battery.
- Check that all electrical connections and cables are in good condition, free from corrosion and connected properly.

WINCH MOTOR OPERATES BUT THE CABLE WILL NOT SPOOL IN:

- Ensure clutch handle is in the engaged position.

WINCH ONLY OPERATES IN ONE DIRECTION:

- Check that all electrical connections and cables are in good condition, free from corrosion and connected properly.
- Check that all wiring is correct as per the diagrams in this manual.
- Check that the hand control switch is not damaged and functioning properly.
- Check that the control box socket is in good condition.

WINCH BRAKE IS NOT WORKING OR HOLDING A LOAD:

- Check that the cable is spooled on the drum in the correct direction

WINCH SOLENOID IS NOT WORKING OR CLICKING RAPIDLY

- Check that the thin earth cable is connected correctly as per the diagram in this manual.