

HALO BOARD™
// BEAST //

User Manual





Before You Begin-----01



Main Components-----02-03



Charging Your Batteries-----04-05



Pairing Your Remote -----06



The Basics -----07-08



Rider Safety-----09-11



Battery Safety -----12-13



Specifications-----14



Warranty-----15



Before You Begin

Before learning to ride your Halo Board, you must read and follow all instructions and warnings in this user manual. It is important that you follow all safety warnings and cautions that appear throughout the user manual and that you use good judgment when you ride your Halo Board electric skateboard.

WARNING! READ BEFORE YOU RIDE!

The Halo Board is an electric powered skateboard that uses brushless hub motors and E-ABS to accelerate and brake. The Halo Board is capable of reaching high speeds and can result in serious injury or death if you do not ride safely. To reduce risk of injury, you must read and follow all instructions and warnings in the user manual.

ATTENTION: HIGH SPEED MODES

Beast Speed Mode must be used only in non-traffic, open areas, where you have a minimum of 150 ft clearance ahead to stop safely.

Your Board Can Lose Power or Brakes at Any Moment

Due to the possibility of your remote or board battery dying, radio interference, or emergency shutdown from overcharging via regenerative braking on a full battery, always ride your Halo Board at speeds and on hills that you would be comfortable riding on a regular skateboard without power or electronic brakes. It may be necessary to use skateboarding techniques such as foot braking and sliding to come to a stop.

Always Wear a Helmet

Using protective gear such as knee and elbow pads, along with wrist guards are also recommended. Falls at high speeds can cause serious injury, protect yourself with the proper gear.

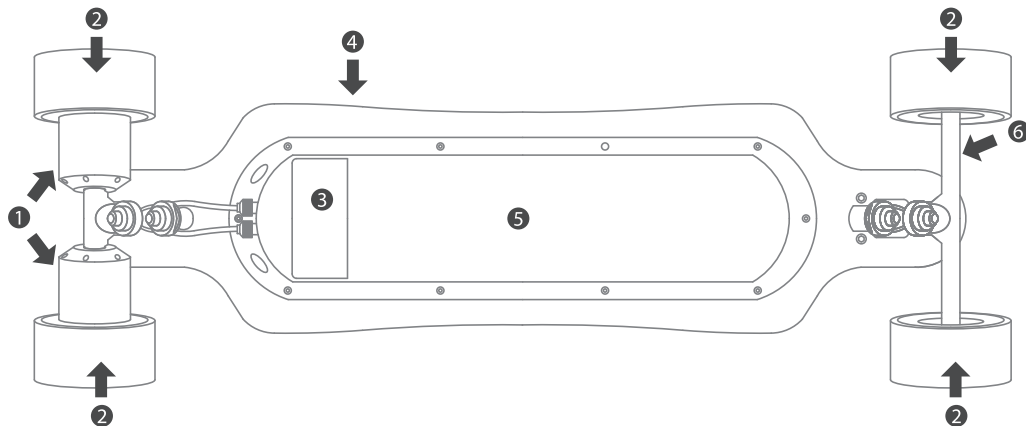

- ① Direct Drive Motors
- ② 97mm Wheels
- ③ Motherboard Cover
- ④ Maple Deck
- ⑤ Carbon Fiber Casing
- ⑥ Front Trucks

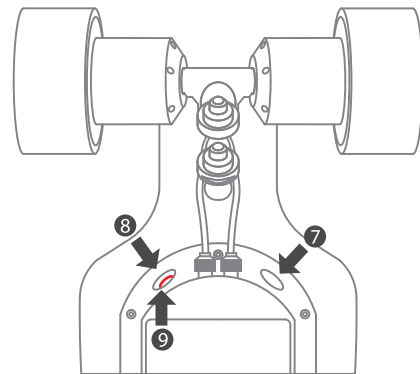

- ⑦ Charging Port
- ⑧ Power Button
- ⑨ Indicator LED

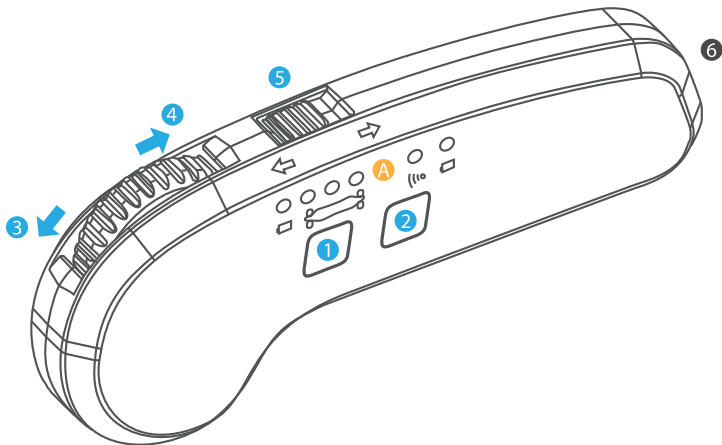

- 1 Power Button¹
- 2 Speed Selector Button
- 3 Accelerate
- 4 Brake
- 5 Forward/Reverse Switch²
- 6 Charging Port

¹ To power on/off remote, press and hold Power Button for 3 seconds.

² Board must come to a stop for Forward/Reverse switch to take effect.

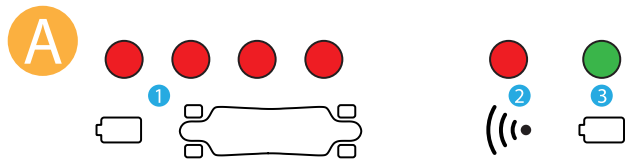

- 1 Halo Board Battery Indicator - When remote powers on and connects with board, the indicator lights will temporarily* light to display the board's battery level.



- 2 Remote Signal Indicator - Will flash slowly when not connected to the board - remains solid once connected to the board.
- 3 Remote Battery Indicator - While remote is on, indicator LED will temporarily* light to display remote's battery level.



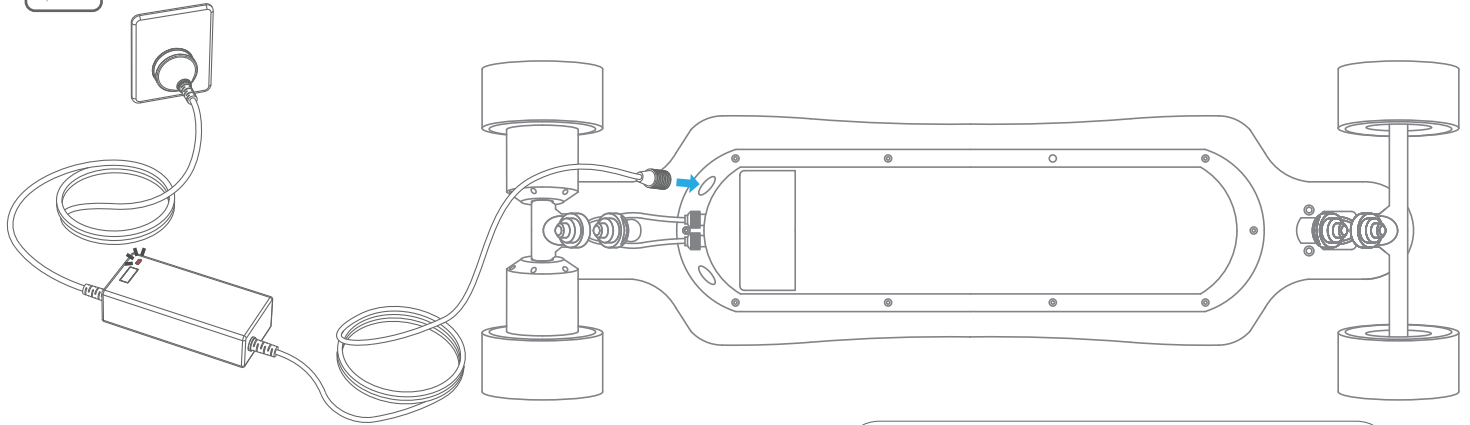

*While on, press Power Button once to display battery indicators again.

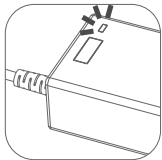

Do NOT insert the power cord plug if the charge port, power cord or AC power outlet is wet.



Battery Charge Indicator Light

- "  " When the Halo Board is plugged in and charging, the battery charge indicator will be solid red.
- "  " When battery charge indicator turns green, the batteries are fully charged.

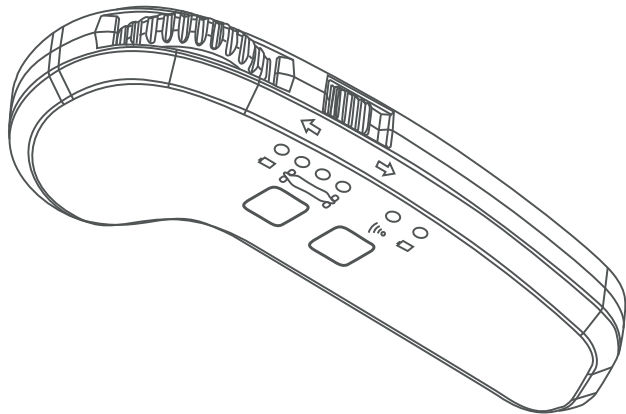

Charge Your Remote

Plug your remote to the included Micro USB cable to charge your remote.

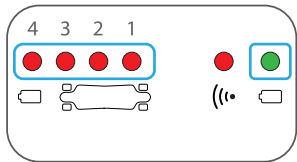

Battery Charge Indicator Light

While charging, the indicator LEDs over the board icon will progressively fill from 1 to 4 until fully charged. Once fully charged, the **Remote LED** indicator on the right will turn from Red "●" to Green "●".



Check to see if You're Paired

Once your board and remote are powered on, check to see if you are paired (the left Signal Indicator LED on the remote should be solid). If you are not paired, follow these steps to pair your remote to your board. Start by powering off the Halo Board and your Halo Remote.

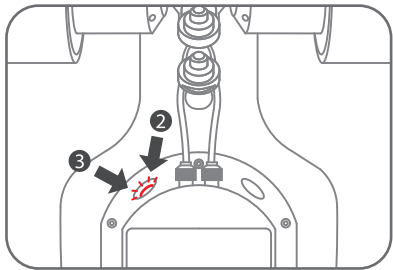

- 1) Ensure everything is powered off.
- 2) Press and hold the power button for 5 seconds.
- 3) The Power Indicator LED on the board will begin to flash.

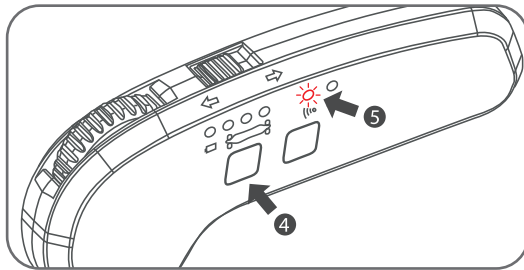

- 4) Press and hold the Remote Power button for 5 seconds, or until the Signal LED goes from flashing slowly to flashing quickly.
- 5) Once it pairs with the board, the Signal Indicator LED light will remain solid red.

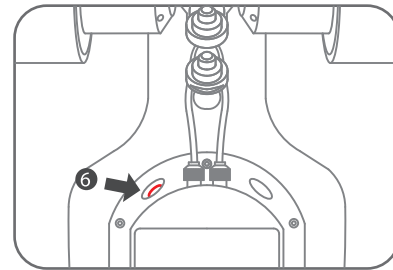

- 6) The flashing indicator LED on the board will also stop flashing and remain solid once the remote and board are paired.



Stance

The best way to find out whether you ride Regular (left foot forward) or Goofy (right foot forward), is just ride and see what's more comfortable for you.



Regular

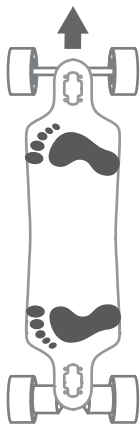

Goofy

The Halo Board uses powerful motors that can throw you off balance if you are not standing properly, or ready for the acceleration or braking. Follow these tips for a safer ride!

- 1) Push the acceleration or pull on the brakes in slow increments until you learn how the Halo Board reacts.
- 2) Stand wide on the board to help balance your weight as it shifts when you accelerate and brake.
- 3) Stay in Speed Mode I (Beginner Mode) until you are comfortable riding the Halo Board.

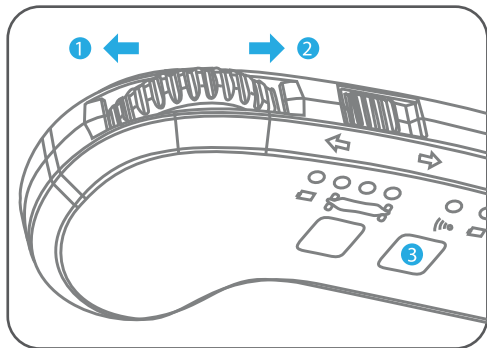

Using Your Halo Remote

- 1) Roll up on the wheel to accelerate (forward or reverse).
- 2) Roll back on the wheel to brake.
- 3) Select your speed using the Speed Selector Button to cycle through the gears:

Speed Mode 1	Low	Up to 10 MPH
Speed Mode 2	High	Up to 20 MPH
Speed Mode 3	Beast	Up to 26 MPH

Accelerating

Lean forwards when accelerating to help keep your balance.

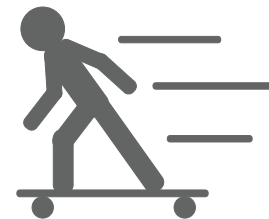

Braking

Lean back when braking to help keep your balance.

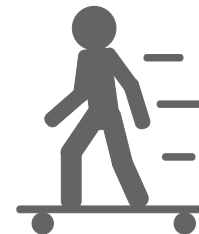



Understand Your Limitations

The Halo Board is at its core a longboard - therefore the same limitations apply on where and how you should ride. Always ride under control at a speed that is safe for you and those around you. Be mindful of others and the road traffic around you.

- ALWAYS wear a helmet.
- Wear other protective gear to keep you safe.
- Find a smooth, flat area to practice riding for the first time.
- Always be prepared to stop, and give pedestrians the right of way.

Avoid Obstacles & Surfaces That Can Cause Loss of Balance or Control



Bumps, Cracks, & Uneven Surfaces

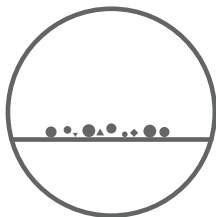

Pebbles, Gravel, & Rocks

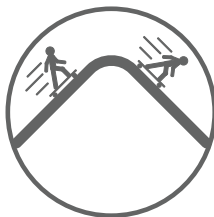

Steep Hills



Water & Wet Surfaces*

* If the Halo Board motors get wet, pick up the board and run the motors at full throttle for a minute to dry them out and avoid rust damage.



When riding the Halo Board you risk serious injury from loss of control, collisions, and falls. It is your responsibility to learn how to safely ride the board in order to reduce this risk. To ride safely you must follow all instructions in this user manual and use your common sense.

- Always wear proper attire when using the Halo Board, do not wear loose clothing that can catch in the wheels or drag on the floor.
- Never place anything on the board except your feet.
- Avoid obstacles and surfaces that could result in a loss of balance or traction and cause a fall.
- Use caution when riding over any terrain change such as pavement to dirt, grass, or speed bumps.
- Avoid holes, curbs, steps, and other obstacles.
- Avoid riding over any surface where the bottom of the Halo Board may impact any object.
- When using on sidewalks, make sure that one side does not drop off the curb.
- Use caution when riding in new environments.
- Be careful and considerate of others while riding.
- Respect pedestrians by always yielding the right of way.
- Avoiding startling pedestrians. When approaching from behind, announce yourself and slow down to walking speed when passing. Pass on the left whenever possible. When approaching a pedestrian from the front, stay to the right and slow down.
- In heavy pedestrian traffic conditions, slow down and proceed at the pace of pedestrian traffic. Pass only if there is ample space to do so safely. Do not weave in and out of pedestrian traffic.



- When riding with other skateboarders, maintain a safe distance, identify hazards and obstacles, and do not ride side-by-side unless there is plenty of room left for pedestrians.
- Cross roads at designated crosswalks or signaled intersections. Do not jaywalk/ride.
- Only travel on a road when a pedestrian way is not available, there is no bike lane, or when sidewalk use is not allowed. Do not ride your board on private property (inside or outside) unless you have obtained permission to do so.
- Learn about and obey applicable local laws and regulations.
- Inspect your Halo Board before each use.
- No passengers. The Halo Board is designed for one rider. Do not ride double or carry any passengers. Do not carry a child in your arms or in a child carrier while riding. Expectant mothers should not ride the Halo Board.
- Do not exceed the maximum weight limit (rider and all cargo) specified in this Manual. If you exceed the maximum weight limit, you are at greater risk of falling and injury.
- Be alert. As with any other transportation device, you must be mentally alert to safely ride. Do not attempt to ride if you are ill or if you cannot fully comply with the instructions and warnings in this manual. Do not ride under the influence of alcohol or drugs. Avoid distractions. Do not use a mobile phone, or engage in any other activity that might distract you or interfere with your ability to monitor your surroundings while riding.
- When riding, keep both feet on the foot mats. Be relaxed. Ride in a relaxed position with your knees and elbows slightly bent and head up.



- Do not use a Battery if the battery pack casing is broken or if the battery emits an unusual odor, smoke, excessive heat or leaks any substance. Avoid contact with any substance seeping from the Batteries.
- Keep out of reach of children and pets. Exposure to battery voltage could result in death or serious injury.
- Unplug or disconnect the board from AC power before removing or attaching Batteries or performing any service. Never work on any part of the Halo Board when it is plugged into AC power source. You risk serious bodily injury from electric shock as well as damage to the board.
- The cells within the batteries contain toxic substances. Do not attempt to open the batteries. Do not insert any object into the batteries or use any device to pry at the battery casing. If you insert an object into any of the battery ports or openings you could suffer electric shock, injury, burns, or cause a fire. Attempting to open the battery casing will damage the casing and could release toxic and harmful substances, and will render the pack unusable.
- Observe and follow all safety information on the warning label found on the batteries.
- Failure to charge the batteries could result in permanent damage to them. Left unplugged, the batteries could fully discharge over time, causing permanent damage.
- Only use charging devices approved by Halo Board and never attempt to bypass or override their charging protection circuits.
- Do not attempt to wash the board with a power washer or high pressure hose. Avoid getting water into the charge port.



- Make sure that the Charge port is dry before you plug in the power cord. Failure to follow these instructions could expose you to electric shock, injury, burns, or cause a fire.
- Do not submerge the batteries or platform in water. If you suspect the Batteries or powerbase have been submerged or experienced water intrusion, do not attempt to remove the batteries. Do not plug the Power Cord into the board. Failure to follow these instructions could expose you to electric shock, injury, burns, or cause a fire.
- As with all rechargeable batteries , do not charge near flammable material.
- If you use, charge, or store the scooter batteries outside the limits specified, you may void the limited warranty, damage your batteries, and/or experience reduced range and ineffective battery charging.

Note: Lithium-ion batteries are regulated as “Hazardous Materials”. Transporting Lithium battery by air, or other methods, might be prohibited by policies or law . Please contact the designated agents from the carrier company for more details.



Lithium-ion Battery	10.4 Ah, 36V 374.4WH
Motors	3200W - Dual 1600W Brushless Direct Drive
Max Speed	Up to 26 MPH
Range	Up to 25 Miles
Max Climbing Limit	25 Degrees
Charge Time	4 - 5 Hours
Deck Material	Maple Deck & Carbon Fiber Battery Casing
Deck Length	37 Inch
Wheels	97mm 74a
Max Load	286 LBS
Product Dimensions	38.5 x 12.5 x 4.5 Inch (L x W x H)
Net Weight	23.3 LBS



This agreement outlines the WARRANTY coverage supplied by HaloBoard.com. The company warrants that the product will be free from defect in materials and workmanship for a period of 6 months. If the product proves defective and a claim is filed during the warranty period, Halo Board, at its option, will:

- Repair the product by means of telephone or email support, or by providing service at no charge for parts or labor.
- Repair the product with new or refurbished parts.

The following situations are beyond the warranty scope (see complete details at HaloBoard.com)

- Total mileage is over 1000 Miles.
- Damage has been caused by modification or used outside those specified in the User Manual.
- The product has been dismantled or repaired by an unauthorized third party.
- Damage or fault has been caused by other issues.
- Natural wear and tear that does not affect product function (scratches, wear and tear on deck, griptape, bearings).
- Damage has been caused by accidents, such as breakage caused by dropping or rusting in wet environment.
- Damage caused by overloading the Halo Board electric skateboard.
- Damage caused by water.
- Damage caused by acts-of-god such as fire, flood, freezing, etc.

Contact support@haloboard.com for all warranty related questions.



QUESTIONS - SUPPORT@HALOBOARD.COM