



MHBHR280A

Model Number: HBHR280GX, HBHR350GX,
HBHS300GX, HBHS310GX, HBHS600GX,
HBHS610GXE, HBHS620GXE

Owner's Manual Brave Hydra Buddy™ Hydraulic Power Pack OPERATION AND MAINTENANCE

About Your Hydraulic Power Pack

Product Suitability and Limitations

Our self-contained hydraulic power units are compact and offer portable hydraulic power for remotely powering hydraulic equipment. Our power units can also be mounted into equipment as a primary hydraulic power source given the flow, pressure, reservoir capacity, and duty cycle are carefully considered. Typical applications include agriculture, construction, trades, lifting, jacking, equipment repair, and fabrication work.

HBHR units come factory with a 4-way directional control valve with integral system relief valve. HBHR units are equipped with ½" quick-disconnects that are installed into the work ports of the directional control valve. HBHS units come factory with a system relief valve.

The HBHS units can also be field retrofitted to include optional bulkhead mounted ½" quick-disconnects with appropriate plumbing kit, and a single 4-way directional control valve with integral relief valve.

The HBHS units driven by the Honda GX630 V-Twin engine can also be field retrofitted with a return line heat exchanger for applications that run more continuous and require additional cooling of the hydraulic fluids. The return line heat exchanger kit comes with a mounting bracket assembly, 12 VDC fan cooler, appropriate plumbing, wire harness, and hardware.

Each unit has a specific flow and pressure rating that should be carefully reviewed to ensure the power pack will provide adequate system flow, pressure, & reservoir capacity for the given application being considered.

Only the HPHS units with the Honda V-Twin engine can support the 12 Volt heat exchanger (cooler) due to the required amp draw from the 12 VDC fan and on-board charging system of the Honda GX630 engine.

Power packs without a return cooler should not be used in applications where hydraulic oil temperatures exceed 180 degrees F for any amount of time. If the hydraulic system reaches 180 degrees F. the system should be shut down immediately and the application should be reviewed.

Contact Brave Customer Service at 1-800-350-8739 about the appropriate use of this Hydraulic Power Pack, optional accessories or any other questions.

Hydraulic Hose and Fitting Requirements

The rated working pressure of hydraulic hoses must be equal to or higher than the maximum pressure rating of the hydraulic unit. Each of the HBHR and HBHS units have a unique pressure rating they are capable of achieving. Please refer to the specific assembly flow and pressure rating and size hydraulic hose and fittings appropriately.

½" quick-disconnects can be provided for each HBHS unit upon request. If the couplers provided do not interchange with the powered equipment, replace with couplers that match. Brave recognizes that couplers are a necessity for quickly connecting and disconnecting equipment however feel that if the self-contained power pack is mounted into a piece of equipment for final assembly that quick-disconnects, adapter fittings, and hydraulic hose plumbing are carefully reviewed to maximize the performance of the hydraulic system. Adding unnecessary couplers, adapter fittings, etc. will increase pressure drop in a hydraulic system and reduce the efficiency of the hydraulic system.

Warranty Registration

Please fill in the warranty registration information in the back of this manual and have it on hand when you call in about a warranty claim or for replacement parts you may need.

Renting or Loaning

NOTICE: Make Owner's Manual Available

All persons to whom you rent/loan the Hydraulic Power Pack must have access to and read this manual. Keep this owner's manual with the Hydraulic Power Pack at all times and advise all persons who will operate the machine to read it. You must also provide instruction on how to safely operate the Hydraulic Power Pack and remain available to answer any questions a renter/borrower might have.

Any Questions, Comments, Problems, or Parts Orders
Call your dealer or Brave Customer Service 1-800-350-8739

Table of Contents

About Your Hydraulic Power Pack.....	1
Receiving and Transporting.....	4
Machine Component Identification	5
Specifications.....	6
Safety	7
Safety Decal Locations	8
Safety Decals	9
Operation	10
Starting and Warm-up Before Use	12
Using Hydraulic Motor Implement	13
Using Hydraulic Cylinder Implement.....	15
Refueling	17
Storing.....	18
Maintenance & Repair	20
Troubleshooting.....	22
Summary of Important Safety Information	24
Special Safety Information on Static Electricity	28
HBHR350GX & HBHR280GX Exploded View - Rev A.....	29
HBHR350GX & HBHR280GX Parts List - Rev A	30
HBHS300GX & HBHS310GX Exploded View - Rev A.....	31
HBHS300GX & HBHS310GX Parts List - Rev A.....	32
HBHS600GXE, HBHS610GXE, & HBHS620GXE Exploded View - Rev A.....	33
HBHS600GXE, HBHS610GXE, & HBHS620GXE Parts List - Rev A	34
Limited Warranty Policy	35
California Proposition 65 Information.....	38

Receiving and Transporting

Initial Inspection: Regardless of the source, immediately inspect the Hydraulic Power Pack for damage or any missing components. *See the “Machine Component Identification” section of this manual for a diagram of the Hydraulic Power Pack and its components.*

Your purchase will result in delivery through one of the following sources:

Truck Delivery

Note: *Shipping damage claims are not covered by Brave warranty.*

For any shipping damage, make sure the delivery driver acknowledges the damage and notes the damage on the shipping documents.

Some assembly may be required with truck delivery. This is detailed in the “Operation: Pre-Start Checklist” section.

Store Purchase

Some assembly may be required. This is detailed in the “Operation: Pre-Start Checklist” section.

From a Dealer

Your unit should have been delivered completely assembled and ready to run.

Read the “Operation: Pre-Start Checklist” section and verify that the unit has been properly ‘prepped’ before initial use.

Transporting: The Hydraulic Power Pack should be secured to prevent rolling and tipping when transporting in a vehicle or trailer.

Any Questions, Comments, Problems, or Parts Orders
Call your dealer or Brave Customer Service 1-800-350-8739

Machine Component Identification

HBHR280GX and HBHR350GX

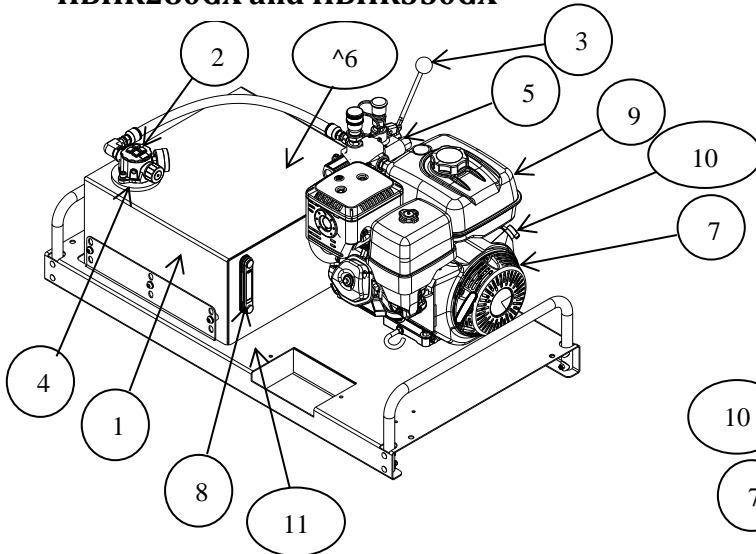

HBHS300GX and HBHS310GX

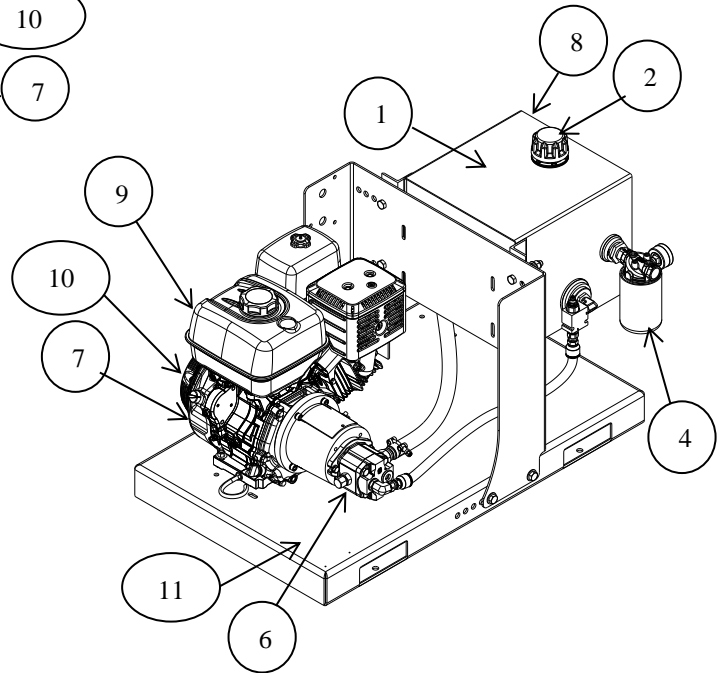

HBHS600GXE, HBHS610GXE, and HBHS620GXE

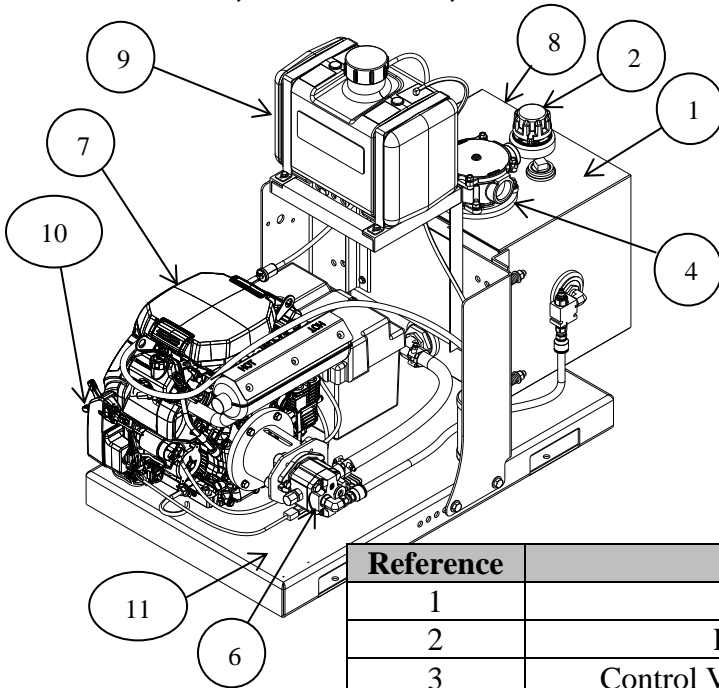

Reference	Part Description
1	Hydraulic Tank
2	Hydraulic Fill Cap
3	Control Valve Handle (HBHR only)
4	Return Line Filter
5	Control Valve (HBHR only)
6	Hydraulic Pump
7	*Engine
8	Sight Gauge
9	Fuel Tank
10	Engine On/Off Switch
11	Nameplate/serial number

*See Engine Manual for Engine Component Identification
 ^Pump is located in tank

Specifications

	HBHR280GX	HBHR350GX	HBHS300GX	HBHS310GX	HBHS600GXE	HBHS610GXE	HBHS620GXE
Engine	Honda GX270	Honda GX390	Honda GX390	Honda GX390	Honda GX630	Honda GX630	Honda GX630
Engine Oil Type	Use Engine Manufacturer's Recommended Oil						
Pump Capacity	5.5 GPM	7 GPM	5 GPM	7 GPM	9 GPM	12 GPM	14 GPM
Pump Displacement	.36 CIR	.51 CIR	.36 CIR	.51 CIR	.66 CIR	.88 CIR	1.02 CIR
Hydraulic Fluid Type	AW32 or ISO 32 Recommended. ISO 46 can be used in warmer climate applications						
Hydraulic Tank Volume (nominal, actual, useable)	8, 7.3, 5.4	15, 13.6, 10.3	9.7, 8.5, 5.75	9.7, 8.5, 5.75	19.2, 17.5, 13.5	19.2, 17.5, 13.5	19.2, 17.5, 13.5
Hydraulic Tank Material	12 gauge steel						
Hydraulic Relief Setting	2000 PSI	2000 PSI	3000 PSI	2000 PSI	3000 PSI	2250 PSI	2000 PSI
Hydraulic Valve Type	3-position, 4-way spring to center direction control valve with integral adjustable main relief valve		N/A (kits available)				
Connection Ports	ISO 7241-1 Series A interchange	ISO 7241-1 Series A interchange	Return, Female -12 SAE ORB; Supply, Male -8 JIC	Return, Female -12 SAE ORB; Supply, Male -8 JIC	Return, Female -20 SAE ORB; Supply, Male -8 JIC	Return, Female -20 SAE ORB; Supply, Male -8 JIC	Return, Female -20 SAE ORB; Supply, Male -8 JIC
Filter Replacement Part Number	1090490	1090490	1090169	1090169	1090368	1090368	1090368
Overall Dimensions	38.25" L x 19" W x 20" H	44.50" L x 24.5" W x 20" H	44" L x 24.5" W x 26" H	44" L x 24.5" W x 26" H	48" L x 24.5" W x 43" H	48" L x 24.5" W x 43" H	48" L x 24.5" W x 43" H
Dry Weight	155 lbs.	198 lbs.	240 lbs.	240 lbs.	368 lbs.	368 lbs.	368 lbs.

Safety

Hazard Signal Word Definitions



This is the safety alert symbol. It is used to alert you to potential personal injury hazards. Obey all safety messages that follow this symbol to avoid possible injury or death.



DANGER (red) indicates a hazardous situation, which if not avoided, will result in death or serious injury.



WARNING (orange) indicates a hazardous situation, which if not avoided, could result in death or serious injury.



CAUTION (yellow), used with the safety alert symbol, indicates a hazardous situation, which if not avoided, could result in minor or moderate injury.



CAUTION (yellow), without the safety alert symbol, is used to address practices not related to personal injury.



NOTICE is used to address practices not related to personal injury.

Safety Decal Locations

⚠ WARNING

ALWAYS make sure safety labels are in place and in good condition. If a safety label is missing or not legible, order new labels from Brave Customer Service at 1-800-350-8739.

HBHR280GX and HBHR350GX

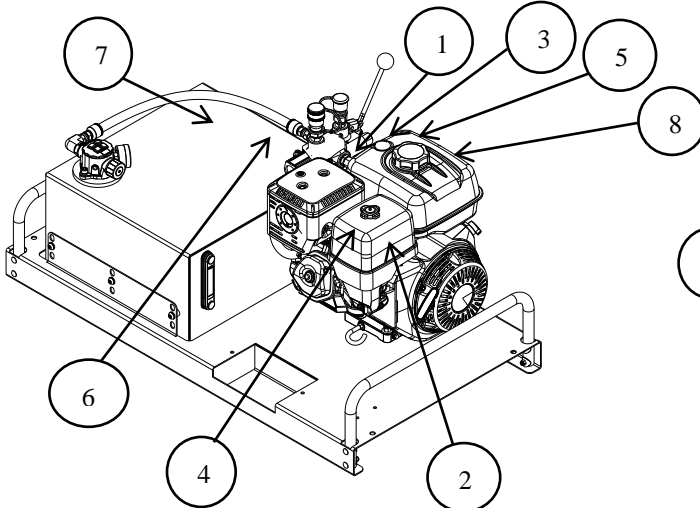

HBHS300GX and HBHS310GX

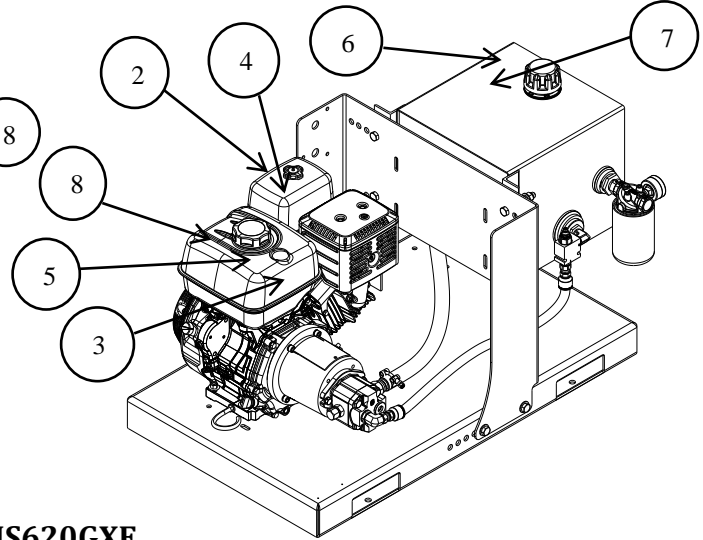

HBHS600GXE, HBHS610GXE, and HBHS620GXE

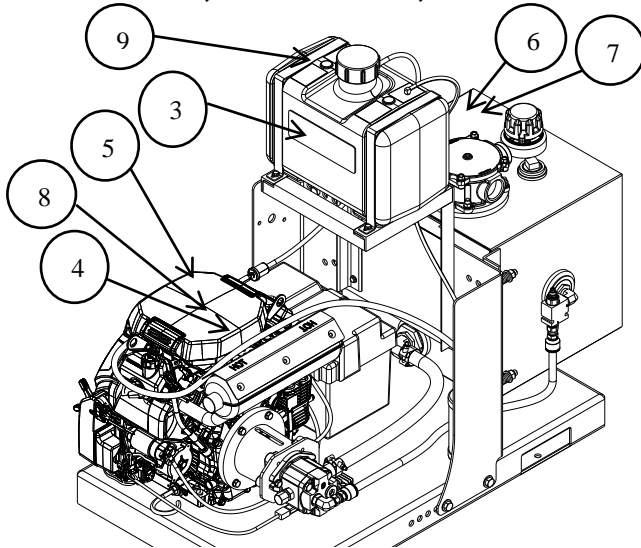

Ref#	Part#	Part Description	Model
1	800119	Control Handle	HBHR280GX, HBHR350GX
2	788937	Carbon Monoxide Warning	HBHR280GX, HBHR350GX, HBHS300GX, HBHS310GX
3	787387	Fire Hazard Warning	All
4	786635	Muffler Warning	All
5	787637	Inspect Lubricate	All
6	800069	Hydraulic Fill	All
7	787395	Hydraulic Fluid Warning	All
8	799546	Proposition 65	All
9	800249	Gasoline Only	HBHS600GXE, HBH610GXE, HBH620GXE

Safety Decals

WARNING

ALWAYS make sure safety labels are in place and in good condition. If a safety label is missing or not legible, order new labels.

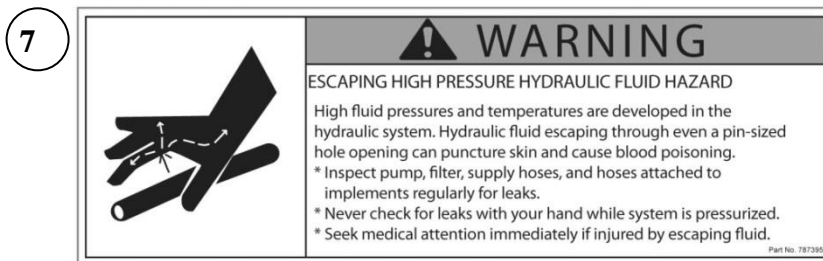
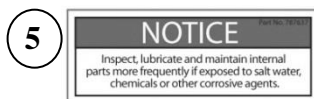
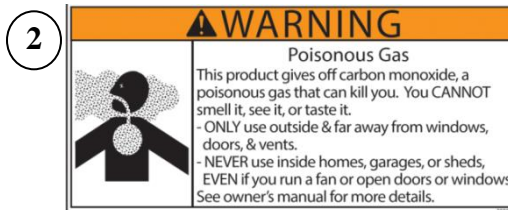
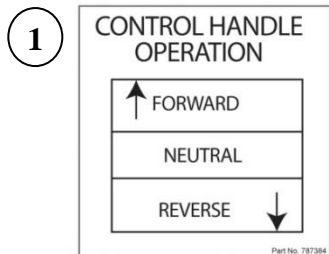

Any Safety Questions, Comments or Problems
 Call your dealer or Brave Customer Service 1-800-350-8739

Operation

Pre-Start Checklist

CAUTION: No Oil in Engine Crankcase

Add the correct amount of oil to engine crankcase or engine will be damaged beyond repair and not covered by warranty.

CAUTION: No Hydraulic Oil in Tank

Add the correct amount of hydraulic oil to the reservoir before use.

1. All HBHS600 series units will require the fuel system to be mounted to the fuel tank bracket; all HBHS300 series units will require the oil filter head and canister be installed; all HBHR units will require the valve handle be mounted and quick connect fittings be installed (if desired).
2. Check / add engine crankcase oil
3. Check / add hydraulic oil
4. Inspect hydraulic system (with engine off)
5. Check Implement Hydraulic System
6. Fill engine gasoline tank (upper tank)
7. Inspect fuel system for leaks (with engine off)

These procedures are discussed in detail below:

1. See separate assembly instruction insert applicable to your unit.
2. Check / add engine crankcase oil
 - Check the oil level daily using the dipstick and add oil as needed.
 - Using a funnel, add oil up to the FULL mark on the dipstick with the recommended oil type for your engine and expected ambient conditions.
 - Replace engine crankcase fill cap to finger tight.
 - (See engine Owner's Manual for oil type and capacity, and more detailed oil check/fill instructions.)
3. Check / add hydraulic oil
 - Verify that the oil is at the top of the gauge on the hydraulic reservoir.
 - If hydraulic oil level is low: Remove hydraulic tank fill cap and add 10 wt. AW32, ASLE H-150, or ISO 32 oil up to the top of the gauge.
 - Replace hydraulic tank fill cap.

WARNING: Hot Oil Hazard

NEVER remove the hydraulic oil fill cap when the engine is running or hot. Hot oil can escape causing severe burns. Allow the Hydraulic Power Pack to cool completely before removing hydraulic oil fill cap.

NOTICE: Attached Implement Hydraulic Oil: Refer to the attached implement owner's manual for its recommended oil. If you are using an implement that requires different oil, it may be incompatible with the above recommended oil, contact Brave.

4. Inspect hydraulic system (with engine off)
 - Visually inspect all Hydraulic Power Pack hoses, tubing, clamps/fittings, pump, and cylinder for cracks, fraying, kinks, or other damage.
 - Check all components for oily residue, which may indicate a leak.
 - Do NOT operate the Hydraulic Power Pack if there is any indication of damage or oily residue.

Operation (Continued)

5. Check implement hydraulic system

Check hydraulic system and lines of the implement to be attached to the Hydraulic Power Pack. Small leaks in hydraulic lines can be an indication of catastrophic failure in the near future. The life of hydraulic hoses may be from a few months to a few years, depending on use and storage patterns.

⚠ WARNING: Pressurized Fluid Hazard

High fluid pressures and temperatures are developed in Hydraulic Power Packs.

NEVER check for leaks with your hand. Leaks can be located by holding a piece of cardboard or wood (at least two feet long) with your hand at one end and passing the other end over the suspected area (wear eye protection). Look for discoloration on the cardboard or wood.

STOP the engine, disconnect the spark plug, and move all control valve handles back and forth to relieve pressure before changing or adjusting hydraulic system components such as hoses, tubing, fittings, or other components.

NEVER adjust the pressure setting of the pump or valve

Hydraulic fluid escaping through a pin-sized opening can burn or puncture skin, resulting in wounds that could cause blood poisoning, infection, disability, gangrene, amputation, or death.

If injured by escaping fluid, no matter how small the wound is, see a doctor at once. A typical injection injury may be a small puncture wound that does not look serious. However, severe infection or reaction can result if proper medical treatment is not administered immediately by a doctor who is familiar with injection injuries.

6. Fill engine gasoline tank (the upper tank)

- Check gasoline tank level.
- Fill tank with fresh unleaded gasoline from a UL approved portable container.

⚠ WARNING: Gasoline Vapor Hazard While Fueling

Gasoline is highly flammable and explosive. Heat, sparks, and flames can ignite gasoline vapors which spread over a large area during fueling. A flash fire ignition and/or explosion will likely result in serious injury or death. The following conditions could result in gasoline ignition/explosion:

Refueling and refueling spills
Gas vapor collection inside enclosures
Static electric sparks
Sparks from electric wiring, batteries, or running engines
Sources of heat (such as a hot engine exhaust)
Open flames, including pilot lights

7. Inspect fuel system for leaks (with engine off)

Inspect the entire fuel system. Look for signs of: leaks or deterioration; chafed or spongy fuel hose; loose connections; loose or missing fuel hose clamps; damaged gasoline tank; or a defective gasoline shut-off valve.

⚠ WARNING: Fuel Leak Hazard

A leaking fuel line or spilled fuel no matter how small can be the source of a fire or explosion when starting or operating the engine.

If Hydraulic Power Pack is in an enclosed area and you smell gas, DO NOT start engine! DO NOT light a match. DO NOT flip on an electrical switch.

Exit area immediately leaving doors open and call fire department.

Starting and Warm-up Before Use

1. If the hydraulic power unit is equipped with a directional control valve, place the Hydraulic valve handle in the neutral position. If unit not equipped with a directional control valve, skip directly to step 6.

⚠ CAUTION: HBHS users without installed directional control valve

If the unit is not equipped with a directional control valve, please ensure the power unit is properly plumbed to the powered equipment prior to attempting to start the engine. Unit cannot be run without implement attached. Damage to engine and hydraulic components can occur.

2. Start the engine per the manufacturer's instructions.
3. Once the engine has started, move the throttle down to the mid-range position and allow the engine to run for ten (10) minutes to warm engine and hydraulic oil.
4. Turn engine off.
5. Clear line pressure by moving the Hydraulic Power Pack valve (if equipped) to the forward position for four (4) or five (5) seconds, then to the reverse position for four (4) or five (5) seconds to relieve pressure.
6. Attach implement's hydraulic hoses (if applicable).
Your Hydraulic Power Pack is now ready for attachment to an implement.

For units that are plumbed directly to equipment, without a valve on the power pack, see the following diagrams which show the supply and return ports and what type of connection is provided at these ports. Remove port plugs/caps in order to attach to these ports.

HBHS600GXE, HBHS610GXE, and HBHS620GXE

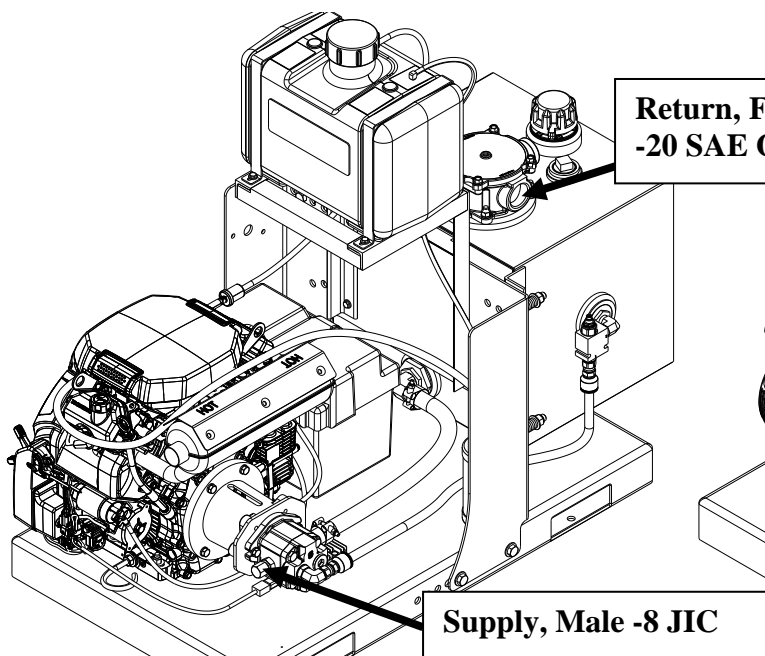

HBHS300GX and HBHS310GX

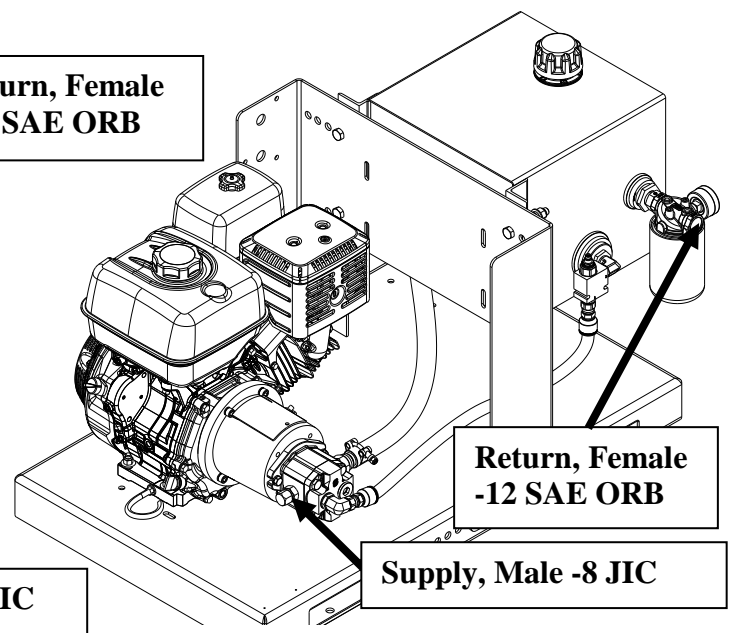

⚠ WARNING: Personal Protective Equipment

Never use the Hydraulic Power Pack or any powered equipment without proper protective equipment, such as eye protection.

Using Hydraulic Motor Implement

NOTICE: Match Quick Disconnect Couplers

If necessary, replace coupler fittings with implement-matching couplers. Brave does not recommend using multiple adapters; they may restrict flow and limit operation.

1. Connect Hoses (Engine Off)

- Before connecting your implement hoses to the Hydraulic Power Pack, you must determine which hose is the pressure or forward acting hose. Consult your implement owner's manual or labels to determine which hose is the "SUPPLY" hose.
- Models HBHR are equipped with a spring to center 3 position 4-way hydraulic valve. The handle will center itself to neutral when the operator removes his hand from the valve. This type of valve can cycle both hydraulic cylinders and hydraulic motors. Refer to the diagram below to determine what port is supply and return when the handle is shifted in either direction. Exercise caution when powering equipment where damage can occur if the oil flow is reversed. Understand the flow of oil with respect to the handle operation on your power unit if equipped with a directional control valve.
- Models HBHS can be ordered with quick coupler plumbing kits, directional control valve plumbing kits, and HBHS600 units can be equipped with a return line heat exchanger kit. Please refer to the kit directions to determine the supply & return ports of the directional control valve or quick coupler plumbing kit.

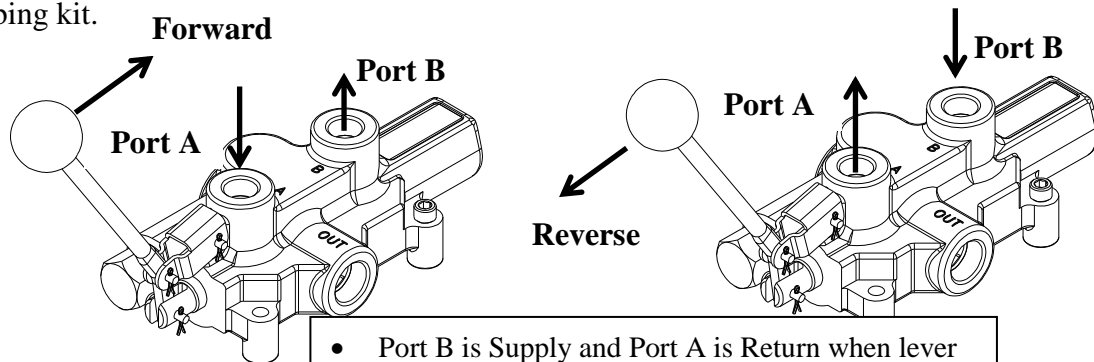

- Port B is Supply and Port A is Return when lever is actuated in the Forward direction.
- Port A is Supply and Port B is Return when lever is actuated in the Reverse direction.

2. Start Engine:

- If equipped with control valves, confirm the valve handle is in the neutral position.
- If equipped without a control valve, confirm supply and return lines are properly plumbed to the driven equipment safely and securely.
- Start engine per manufacturer's instructions.
- Place the engine throttle control lever in the fast position.

3. Normal Operation Mode:

- Forward-Reverse operations are activated when the operator cycles the spring to center valve (if equipped) on the power unit. If the power unit isn't equipped with a directional control valve, please refer to the power equipment owner's manual for proper operation of the power equipment.

CAUTION: Reverse Operation Equipment Damage

The Hydraulic Power Pack has a bidirectional valve that allows you to reverse the direction of an implement motor (or pump). Before using the reverse feature, consult your implement owner's manual to make sure the motor (or pump) can be reversed. Using reverse oil flow in a non-reversing pump or motor can result in damage to your implement.

Using Hydraulic Motor Implement (Continued)

4. Stopping or Removing Attached Implement with Hydraulic Motor:

- To turn off the engine, verify the valve handle is in the center (neutral) position which should cause the hydraulic motor to come to a complete stop.
- Turn the engine off using on/off switch located on engine.
- Confirm the hydraulic motor has come to a complete stop.
- Operate any switches or valves in the system to relieve pressure.
- Move the Hydraulic Power Pack valve handle to the forward position for four (4) to five (5) seconds, then to the reverse position for four (4) to five (5) seconds to relieve pressure.
- Operate any other valves or switches on accessory items to relieve pressure.
- If hoses are connected with quick disconnects, disconnect the hoses.

Using Hydraulic Cylinder Implement

NOTICE: Match Quick Disconnect Couplers

If necessary, replace coupler fittings with implement-matching couplers. Brave does not recommend adapters; they may restrict flow and limit operation.

1. Connect Hoses (Engine Off)

- Before connecting your implement hoses to the Hydraulic Power Pack, you must determine which hose is the pressure or forward acting hose. Consult your implement owner's manual or labels to determine which hose is the "SUPPLY" hose.
- Models HBHR are equipped with a spring to center 3 position 4-way hydraulic valve. The handle will center itself to neutral when the operator removes his hand from the valve. This type of valve can cycle both hydraulic cylinders and hydraulic motors. Refer to the diagram below to determine what port is supply and return when the handle is shifted in either direction. Exercise caution when powering equipment where damage can occur if the oil flow is reversed. Understand the flow of oil with respect to the handle operation on your power unit if equipped with a directional control valve.
- Models HBHS can be ordered with quick coupler plumbing kits, directional control valve plumbing kits, and HBHS600 units can be equipped with a return line heat exchanger kit. Please refer to the kit directions to determine the supply & return ports of the directional control valve or quick coupler plumbing kit.

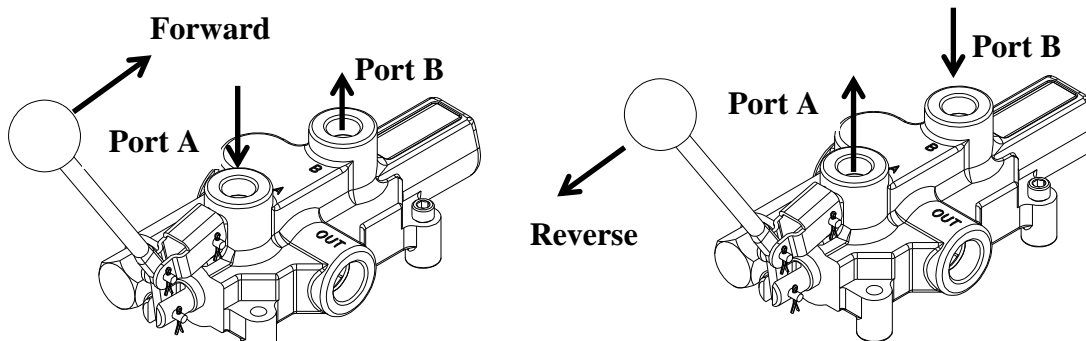

- Port B is Supply and Port A is Return when lever is actuated in the Forward direction.
- Port A is Supply and Port B is Return when lever is actuated in the Reverse direction.

⚠ WARNING: Crush Hazard

The Hydraulic Power Pack valve does not have a positive locking device to hold the cylinder in position. Always use a mechanical lock to prevent the cylinder from creeping/drifts.

⚠ WARNING

Applications with large cylinders can excessively deplete the Hydraulic Power Pack's hydraulic tank.

DO NOT use this unit in applications where more than 75% of the hydraulic fluid is purged from the hydraulic tank or with a cylinder storing a larger oil reserve than the Hydraulic Power Pack.

DO NOT attempt to add more hydraulic fluid during operation to extend the hydraulic capacity.

Failure to follow these warnings could result in damage to property/equipment, personal injury, and death in serious cases.

Using Hydraulic Cylinder Implement (Continued)

2. Start Engine:

- Confirm the valve handle is in the neutral position (all units used to run cylinders should have a valve present in the system).
- Confirm supply and return lines are properly plumbed to the driven equipment safely and securely.
- Start engine per manufacturer's instructions.
- Place the engine throttle control lever in the fast position.

3. Normal Operation:

- To raise the cylinder, push the handle in the forward direction until the desired height is reached, then release the handle (it will automatically return to the center position). Important: block or lock the implement at the desired height. If the implement is not locked into position, the Hydraulic Power Pack will allow the cylinder to drift.
- To lower the cylinder, push the handle in the reverse direction until the desired height is reached, then release the handle (it will automatically return to the center position).

4. To Stop or Remove Attached Implement with Hydraulic Cylinder(s):

- To remove the unit, first place the implement cylinder in the fully retracted position (so the rod is inside the cylinder barrel).
- Then, verify the valve handle is in the center (neutral) position.
- Turn the engine off using on/off switch located on engine.
- Move the valve handle to the forward position for four (4) to five (5) seconds, then to the reverse position for four (4) to five (5) seconds to release system pressure.
- If hoses are connected with quick disconnects, disconnect the hoses.

Refueling

WARNING: Fire Hazard

Allow the engine to cool for at least five (5) minutes before refueling, moving to storage or transporting. A hot engine can be a fire hazard.

Refueling at Work Sites:

- Before removing gas cap, turn engine off and allow to cool for at least FIVE (5) minutes.
- Remove gasoline cap
- Use only a UL-approved portable gasoline container to transfer the gasoline to the Hydraulic Power Pack's gas tank
- Add gasoline through the fill opening
- Clean up gasoline spills /splashes immediately
- Replace gasoline cap securely
- If possible, move the Hydraulic Power Pack away from spilled gasoline on the ground
- Wipe up spilled gasoline and wait five (5) minutes for excess gasoline to evaporate before starting engine
- Gasoline soaked rags are flammable and should be disposed of properly
- If gasoline is spilled on your skin or clothes, wash skin and change clothes immediately
- Store extra gasoline in a cool, dry place in a UL listed, tightly sealed container

Refueling at Gas Stations:

WARNING: Static Electric Spark Hazard

A static electric spark can explosively ignite gasoline vapor, resulting in a flash fire that could cause serious injury or death. See "Special Safety Information on Static Electricity" at end of this manual.

- Use only a UL listed portable gasoline containers
- Never fill the gasoline tank directly from the fuel pump. The tank is not grounded and high velocity flow from the pump can cause static electricity build-up.
- Use a portable container made of metal or conductive plastic. This is preferred because it dissipates static charge to ground more readily.
- ALWAYS place container on the ground to be filled. Never fill a portable gasoline container while it is sitting inside a vehicle, trailer, trunk, or pick-up truck bed.
- Keep nozzle in contact with container while filling. Do not use a nozzle lock-open device.

Storing

Allow engine to cool before inspecting and storing

1. Inspect for worn or damaged parts
 2. Choose a covered storage location
 3. Start engine every 4 weeks;
- OR-
4. Prepare engine for long-term (seasonal) storage if needed.

1. Inspect for worn or damaged parts:

Inspect the Hydraulic Power Pack for worn or damaged parts and tighten any nuts or screws that may have become loose. Check for any fuel or hydraulic system leaks.

2. Choose a covered storage location:

Store the Hydraulic Power Pack in a location that is:

- Clean and dry.
- Away from sources of heat, open flames, sparks, and pilot lights, even if the gas tank is empty. (Residual gasoline fumes can still ignite)
- Away from extreme high or low temperatures.
- Cover for extra protection.

WARNING: Stored Gasoline Vapor Fire Hazard

Gasoline is highly flammable and explosive. Drain the fuel into an approved container OUTDOORS and far away from open flame.

NEVER store an engine with fuel in the tank indoors or in poorly ventilated spaces where fuel vapor can come in contact with:

Static electric sparks;
Sparks from electric wiring, batteries, or running engines;
Sources of heat (such as hot engine or exhaust);
Open flames, including pilot lights.

3. Start engine every 4 weeks:

For future easy starting and to minimize maintenance requirements, the Hydraulic Power Pack should be started at least every four weeks and run for 10 to 15 minutes.

Monthly exercising of the engine will dry out any moisture that has accumulated, lubricate cylinders, and clean out old gas in the carburetor. Moisture, old gas, and dry mechanical parts cause deterioration in stored engines.

CAUTION: HBHS users without installed directional control valve

If the unit is not equipped with a directional control valve, please ensure the power unit is properly plumbed to the powered equipment prior to attempting to start the engine. Unit cannot be run without implement attached. Damage to engine or hydraulic components can occur.

Storing (Continued)

4. Prepare engine for long-term (seasonal) storage if needed:

If you will not be able to start the engine regularly, you must prepare the engine for long term storage to prevent gum deposits from forming and causing malfunction of the engine.

Prepare engine for long-term storage by either removing all gasoline from the tank and carburetor, OR by adding fuel stabilizer to the gasoline. Follow fuel stabilizer manufacturer's instructions, which usually include these steps:

- Ensure gas tank is full.
- Add fuel stabilizer to fuel tank.
- Run engine at least 10 minutes after adding stabilizer to allow it to enter the fuel system.
- Shut off engine.
- Disconnect spark plug wire and remove spark plug.
- Add one teaspoon oil through spark plug hole.
- Place rag over spark plug hole and turn starter (or pull the recoil) a few times to lubricate the combustion chamber.
- Replace spark plug, but do not reconnect the spark plug wire.

Maintenance & Repair

Regular Maintenance

Perform regular maintenance to keep the Hydraulic Power Pack in safe and functional working condition.

WARNING

ALWAYS shut off the engine, make sure the engine is cool, and disconnect the spark plug before cleaning, adjusting, or servicing the Hydraulic Power Pack.

1. Follow safety rules:

Turn off the Hydraulic Power Pack. To prevent accidental starting, always turn off the Hydraulic Power Pack and remove spark plug or spark plug wire.

Avoid burns. Muffler, crankcase oil and hydraulic oil will remain hot for several minutes even after unit is stopped. Allow to cool before servicing.

2. Perform periodic engine maintenance:

Perform engine maintenance as specified in the engine owner's manual. Engine maintenance items include:

- Oil and oil filter changing
- Air filter check/replacement
- Spark plug cleaning and replacement
- Fuel filter check/replacement
- Fuel tank cleaning

3. Inspect fuel system/check for leaks:

Inspect the fuel system and check for leaks on a regular basis.

Look for: signs of leaks or deterioration, chafed or spongy fuel hose, loose connections, loose or missing fuel hose clamps, damaged gasoline tank, or defective gasoline shut-off valve.

WARNING: Fuel Leak Hazard

A leaking fuel line no matter how small can be the source of a fire or explosion when starting or operating the engine.

4. Inspect hydraulic system/check for leaks:

The hydraulic system (hoses and pump) should be carefully inspected before each use. Also inspect the mechanical parts at the same time. Make sure all hoses, clamps, nuts, bolts, fittings, etc., are properly installed and tightened.

Always replace frayed, kinked, or cracked hoses and/or other damaged hydraulic components with Brave authorized parts and components specified in the "Parts List" section of this manual.

Should it become necessary to loosen or remove any hydraulic fitting or hose, be sure to relieve all hydraulic pressure by shutting off the engine, removing spark plug wire, and moving the valve control handle back and forth several times.

WARNING: Hot Oil Hazard

NEVER remove the hydraulic oil fill cap when the engine is running or hot. Hot oil can escape causing severe burns. Allow the Hydraulic Power Pack to cool completely before removing hydraulic oil fill cap.

Maintenance & Repair (Continued)

5. Hydraulic oil & filter change:

Each self-contained HBHR and HBHS unit is equipped with a filter condition indicator gauge. This gauge should be monitored and when the indicator gauge is no longer in the green the filter element should be replaced. In the event that water is present in the hydraulic oil the system should be completely drained, lines flushed, and oil replaced. Brave recommends an oil change every 100 hours of operation. Add 10 wt. AW32, ASLE H-150, or ISO 32 oil to the top of gauge located on side of tank. See filter change instructions insert (separate from owner's manual). Magnetic drain plug can be found on the bottom of the hydraulic tank.

WARNING

Never run the Hydraulic Power Pack unless the hydraulic oil level is at the top of gauge located on side of tank.

Repairs and Parts

Repairs. Major service, including the installation or replacement of parts, should be performed only by a qualified technician.

Replacement parts. If a part needs replacement, only use factory approved repair parts. Replacement parts from secondary suppliers (not original Brave replacement parts) can lead to product damage and/or personal injury, and will void the warranty. Also, replacement parts that do not meet specifications may result in a safety hazard or poor operation of the Hydraulic Power Pack. Obtain factory-approved parts from Brave Customer Service at 1-800-350-8739.

Maintenance Schedule

Type of Maintenance	Frequency
Check Hydraulic Oil Level	Daily
Check Hydraulic Oil is Clean	Daily
Change Hydraulic Oil	Annually/100 hrs.
Clean Magnetic Drain Plug	Each Hydraulic Oil Change
Replace Return Line Filter	First 50 hrs. / 250 hrs.
Check Coupling Assembly	250 hrs.

Troubleshooting

WARNING

Before troubleshooting or attempting to service, read the following safety instructions to avoid serious injury to the operator or bystanders from moving parts that can crush or cut, burns, fire or explosion, or escaping high pressure hydraulic fluid.

Important Safety Instructions:

Engine off. Always make sure the engine is off before cleaning, repairing or adjusting the Hydraulic Power Pack, except as recommended by the manufacturer.

Hydraulic safety. High fluid pressures and temperatures are developed in the Hydraulic Power Pack . Hydraulic fluid escaping through a pin hole sized opening can burn or puncture skin, resulting in wounds that could cause blood poisoning, infection, disability, gangrene, amputation, or death. Therefore, the following instructions should be heeded at all times when inspecting or servicing the hydraulic components of the log splitter:

- Stop the engine, disconnect the spark plug, and move all control valve handles back and forth to relieve pressure before changing or adjusting hydraulic components such as hoses, tubing, fittings, or other components.
- Do not remove the hydraulic oil fill cap when the engine is running. Hot oil can escape causing severe burns. Allow the log splitter to cool completely before removing the hydraulic oil fill cap.
- Do not adjust the pressure setting to the pump or valve.
- Do not check for leaks with your hands. Leaks can be located by holding a piece of cardboard or wood (at least 2 feet long) with your hand at one end and passing the other end suspected area (wear eye protection). Look for discoloration of the cardboard or wood.
- If injured by escaping fluid, no matter how small the wound is, see a doctor at once. A typical injection injury may be a small puncture that does not look serious. However, severe infection or reaction can result if proper medical treatment is not administered immediately by a doctor who is familiar with injection injuries.

Troubleshooting (Continued)

Problem	
Engine stalls when valve engaged	Cause: 1, 2, 4, 22, 24
Motor or cylinder moves slow	Cause: 1, 3, 5, 7, 22, 24, 25
Engine appears to be seized	Cause: 1, 2, 6, 7, 8, 24
Motor or cylinder moves erratically	Cause: 3, 9, 10, 11, 12, 18, 19, 20, 22, 23, 24, 25
Engine won't turn or stalls at no load	Cause: 10, 14, 16, 21, 23, 24
Pump shaft seal leaks	Cause: 9, 11, 12, 13, 14, 15, 16, 17
Cause	Solution
1. Bad connection at hydraulic coupler. (E, J)	A. Keep oil tank full and clean.
2. Lines reversed. (C)	B. Clean vent hole.
3. Worn ball seat on coupler. (E)	C. Slowly reverse position of valve handle. If implement moves shut down and reverse lines.
4. Auger plugged or jammed.	D. Shut engine off, remove debris.
5. Lower hydraulic oil in reservoir. (A, H)	E. Shut off engine, remove and inspect the hydraulic coupler for worn area, if found remove and replace.
6. Pressure lock. (B, D, E, J)	F. Flush and clean hydraulic system.
7. Defective pump. (L)	G. Shut down engine and inspect oil levels. Fill to adequate levels or change.
8. Defective engine. (L)	H. Remove pump and check to see that it moves freely.
9. Air in system (A, I)	I. Shut engine off then restart.
10. Insufficient oil to pump. (A, E, F, G, H, J)	J. Check hoses for damage and correct placement.
11. Tank breather plugged. (B)	K. Precise alignment of engine and pump is necessary (do not force).
12. Shaft seal improperly vented. (L)	L. Return component to dealer/manufacture for necessary repairs.
13. Leakage through pump check valve. (L)	
14. Pump high pressure gear set damaged. (L)	
15. Pump gear set worn. (L)	
16. Pump seized-up. (H, L)	
17. Drive shaft broken. (L)	
18. Internal leakage in directional valve. (F, H, L)	
19. Directional valve damaged. (L)	
20. Obstruction in directional valve. (F, H, L)	
21. Obstruction in hydraulic lines. (F, H, J, L)	
22. Weak engine-low horsepower. (D, L)	
23. Low engine speed. (D, L)	
24. Improper engine/pump alignment. (K, L)	
25. Shaft coupling loose. (K, L)	

Summary of Important Safety Information

This section provides a summary of the various safety procedures and measures that have been presented through the manual. Keep this summary handy and refer to it to refresh your memory about how to safely use your Hydraulic Power Pack.

WARNING

Carefully read and make sure you understand the following safety information before using the Hydraulic Power Pack. Improper use or maintenance of the Hydraulic Power Pack can result in serious injury or death to the operator and/or bystanders from fire/explosion, carbon monoxide poisoning, injection injuries, or burns.

General

Read manual. Read this Owner's Manual and the engine Owner's Manual completely before attempting to use and service the Hydraulic Power Pack. Serious injury or death can result if safety instructions are not followed.

Instruct operators. The Hydraulic Power Pack owner or rental company must instruct all operators in safe Hydraulic Power Pack set-up and operation. Do not allow anyone to operate the Hydraulic Power Pack who has not read the Owner's Manual and been instructed in its safe use.

Adults only. Only trained adults should operate and service the Hydraulic Power Pack. Do not let children operate.

Under the influence. Never operate, or let anyone else operate, the Hydraulic Power Pack while under the influence of alcohol, drugs, or medication.

Intended use. Carefully read about and understand the intended use of this Hydraulic Power Pack. Do not use for other purposes, as unforeseen hazards or equipment damage may result.

Controls and safety labels. Learn how to use the machine and its controls. Understand and follow all safety labels.

Prohibition Against Modifications

Never modify or alter the Hydraulic Power Pack in any way. Modifications can create serious safety hazards and will also void the warranty.

Fuel/exhaust system. Never modify the exhaust system, fuel tanks, or fuel lines. Carbon monoxide poisoning, fire, or explosion could result.

Pressure setting. Never increase the pressure setting of the pump or control valve.

Safety – Before Use

Know how to operate. Be thoroughly familiar with all controls and with the proper and safe use of the equipment. Know how to stop and de-energize the Hydraulic Power Pack quickly if needed.

Getting Ready

Operate OUTSIDE only – dangerous carbon monoxide exhaust! Hydraulic Power Packs give off carbon monoxide exhaust, a poisonous gas that can kill. You CANNOT smell it, see it, or taste it. ONLY run Hydraulic Power Pack OUTDOORS and away from building air intakes. NEVER run Hydraulic Power Pack inside homes, garages, sheds, or other semi-enclosed spaces. These spaces can trap poisonous gases.

Cooling ventilation. The Hydraulic Power Pack needs adequate, unobstructed flow of air to allow for proper cooling of engine. Do not allow debris to accumulate and block airflow.

Transporting. When transporting, take precautions to make sure Hydraulic Power Pack will not tip over and cause a fuel leak hazard. Tie down in upright position during transportation. Where engine includes a fuel shut-off, shut off fuel.

Summary of Important Safety Information (Continued)

Hot exhaust – fires. Exhaust from engine can be extremely hot and cause fire. Position muffler at least 7 feet from combustible objects during operation.

Fire extinguisher. Keeping a fire extinguisher rated “ABC” by the National Fire Protection Association nearby is always recommended when using gasoline-operated machinery. Keep it properly charged and be familiar with its use.

Personal Protective Equipment

Hearing protection. The use of earplugs or other hearing protection device is recommended for those in close proximity to the Hydraulic Power Pack while it is operating.

Eye protection. Wear ANSI-approved eye protection when operating the Hydraulic Power Pack.

Loose/dangling. Loose or dangling apparel, jewelry or hair can become entangled in moving parts. Never wear jewelry or loose-fitting clothing when operating the Hydraulic Power Pack and attached implements.

Gasoline Safety

Gasoline is highly flammable and explosive. You can be burned or seriously injured. Use extreme care when handling gasoline.

Fuel outdoors. Fill fuel tank outdoors – never indoors. Gasoline vapors can ignite if they collect inside an enclosure. Explosion can result.

Use approved container. Never pump fuel directly into engine at service station. Static charge can build and ignite fuel. Use a UL listed fuel container to transfer gasoline to the engine.

Running/hot engine. A running engine is hot enough to ignite fuel. Never add fuel or remove gas cap if engine is running or still hot. Stop the engine and allow to cool at least five minutes before adding fuel.

Heat/flames/sparks. Keep sources of heat, flame, or sparks away while adding fuel.

Don't fill to the top. DO NOT overfill the gasoline tank. Allow at least 1” of empty space below the fill neck to allow for fuel expansion and operation on slopes.

Replace cap. Replace gasoline cap securely before starting engine.

Spills. Clean up fuel spills immediately. Move Hydraulic Power Pack away from spilled fuel on the ground. Wipe fuel off engine and wait 5 minutes for excess fuel to evaporate before starting engine. Gasoline-soaked rags should be disposed of properly.

On skin/clothes. If gasoline is spilled on your skin or clothes, wash skin and change clothes immediately.

Inspect fuel system. Check fuel system on a regular basis. Look for signs of leaks, deterioration, chafed or spongy fuel hose, loose or missing fuel hose clamps, damaged fuel tank, or a defective fuel shut-off valve. Do not start Hydraulic Power Pack until needed repairs have been completed.

Gasoline storage. Store gasoline in a cool, dry place in a UL listed, tightly sealed container away from children.

Hydraulic System Safety

Check the hydraulic system (hoses, tubing, clamps/fittings, pump, and cylinder) carefully before each use. Do not operate the Hydraulic Power Pack or its attachments with frayed, kinked, cracked, or damaged hydraulic hoses, fittings, or tubing.

High fluid pressures and temperatures are developed in Hydraulic Power Packs. Hydraulic fluid escaping through a pin-size opening can burn or puncture skin, resulting in wounds that could cause blood poisoning, infection, disability, gangrene, amputation, or death.

Do not remove the hydraulic oil fill cap when the engine is running. Hot oil can escape causing severe burns. Allow Hydraulic Power Pack to cool completely before removing hydraulic oil fill cap.

Summary of Important Safety Information (Continued)

Do not adjust the pressure setting of the pump or valve.

Do not check for leaks with your hand. Leaks can be located by holding a piece of cardboard or wood (at least two feet long) with your hand at one end and passing the other end over the suspected area (wear eye protection). Look for discoloration of the cardboard or wood.

Stop the engine, disconnect the spark plug, and move all control valve handles back and forth to relieve pressure before changing or adjusting hydraulic system components such as hoses, tubing, fittings, or other components.

If injured by escaping fluid, no matter how small the wound is, see a doctor at once. A typical injection injury may be a small puncture wound that does not look serious. However, severe infection or reaction can result if proper medical treatment is not administered immediately by a doctor who is familiar with injection injuries.

Safety – During Use

Safety equipment/controls. Always operate the Hydraulic Power Pack with all controls properly adjusted for safe operation.

Check for gasoline leak before starting. After opening gasoline valve, smell for gasoline before starting engine. If you smell gasoline, DO NOT start engine. DO NOT light a match. DO NOT flip on an electrical switch. Exit area immediately and call fire department.

Operating speed. Always operate the Hydraulic Power Pack at the manufacturer's recommended speed. The maximum speed of the engine pump is preset within safe limits.

Know how to stop. Know how to stop the Hydraulic Power Pack quickly if needed. Do the following in order until unit is stopped. (1) First, use on/off switch on engine. (2) Alternatively, engage full choke to flood engine. (3) Pull spark plug wire using an electrically insulated tool or glove.

Damaged. Do not operate the Hydraulic Power Pack with damaged, missing, incorrectly adjusted, or broken parts.

Carbon monoxide exhaust. The running engine gives off carbon monoxide, a poisonous gas that can kill you. You CANNOT smell it, see it, or taste it. If you start to feel sick, dizzy, or weak while using the Hydraulic Power Pack, shut off the engine and get to fresh air RIGHT AWAY. See a doctor. You may have carbon monoxide poisoning.

Other exhaust dangers. This product contains or emits chemicals known to the State of California to cause cancer, birth defects or other reproductive harm. Avoid inhalation of exhaust.

Smoking/sparks. Never smoke near the running Hydraulic Power Pack, and never operate near sources of sparks or flames.

Hot muffler. Never touch hot muffler or hot exhaust manifold. Exhaust and engine parts can be very hot and will burn you.

Moving parts. Keep hands, feet, and apparel away from moving parts of unit or its attachments.

Refueling. DO NOT refuel the engine until it has cooled at least five minutes.

Malfunction during operation. Always shut the machine off if any unusual noise or vibration occurs.

Vibration. Overexposure to any machine vibration daily may lead to circulatory or nerve damage.

Adjusting/repairing. Always turn off Hydraulic Power Pack and remove spark plug or spark plug wire before working on the Hydraulic Power Pack to prevent accidental starting.

Summary of Important Safety Information (Continued)

Safety – After Use

Cool engine before storing. Let engine cool for at least five (5) minutes before storing. A hot engine can be a fire hazard.

Shut off fuel supply. If equipped, make sure gasoline shut-off lever is in the closed position (to the left).

Prevent accidental starting. When Hydraulic Power Pack is not in use, remove key from starter (electric start engines) and secure in a safe location, or remove spark plug in order to ensure that Hydraulic Power Pack cannot be started in a storage location or by untrained persons.

Storage location. Store the Hydraulic Power Pack in a dry location away from sources of heat, open flames, sparks or pilot lights, such as water heaters, space heaters, furnaces, clothes dryers, or other gas appliances, **EVEN IF** the Hydraulic Power Pack's gas tank is empty. Residual gasoline could ignite.

Exercise regularly. Exercise the Hydraulic Power Pack's engine every four (4) weeks to dry out moisture that accumulates in the windings. If engine cannot be exercised on a regular basis, prepare it for long-term (seasonal) storage.

Safety – Inspection/Maintenance

Inspect and maintain your Hydraulic Power Pack on a regular basis and repair as needed to keep it in safe working condition:

Turn off Hydraulic Power Pack. Always turn off Hydraulic Power Pack and remove spark plug or spark plug wire before working on the engine or Hydraulic Power Pack to prevent accidental starting.

Burns. Do not touch hot muffler. Muffler will be hot even if unit is stopped. Allow unit to cool before servicing.

Burns. Do not remove hydraulic oil fill cap when the engine is running or hot. Hot oil can escape and cause severe burns. Allow Hydraulic Power Pack to cool completely before removing hydraulic oil fill cap.

Replacement parts. If a part needs replacement, only use parts that meet the manufacturer's specifications. Replacement parts that do not meet specifications may result in a safety hazard or poor operation of the Hydraulic Power Pack and will void the warranty.

Any Safety Questions, Comments or Problems
Call your dealer or Brave Customer Service 1-800-350-8739

Special Safety Information on Static Electricity

Accidents Involving Static Electricity

Static electricity and filling gasoline containers. Static electricity can initiate from ungrounded gasoline tanks or containers, from flowing gasoline, and from persons carrying a static electric charge.

Static electricity on numerous occasions has explosively ignited gasoline vapors that were present during fueling processes, resulting in serious burns to nearby persons. To avoid static electricity while fueling, certain steps must be followed before and during the fueling process in order to minimize and safely dissipate static charge build-up.

Filling Portable Containers at Service Stations:

Use a portable container to fill Hydraulic Power Pack tank. Never fill the Hydraulic Power Pack's gasoline tank directly from the service station's fuel dispenser pump – the Hydraulic Power Pack's tank is not grounded and the high velocity flow of gasoline from a fuel pump can cause static electric build-up. Use a UL-approved portable container to transfer gasoline to the Hydraulic Power Pack's tank.

Use a portable container made of metal or conductive plastic. It will dissipate charge to ground more readily.

Fill container on the ground. Never fill the portable gasoline container while it is sitting inside a vehicle, trailer, trunk, or pick-up truck bed. ALWAYS place container on the ground to be filled.

Touch a grounded metal object before starting. Always dissipate static charge from your body before beginning the fueling process by touching a grounded metal object that is a safe distance away from fuel sources.

Keep nozzle in contact with container. Keep fuel dispenser nozzle in contact with the portable container at all times while filling at a service station. Do not use the nozzle lock-open device on the dispenser hose.

About static electricity and fueling

Many common objects can accumulate and retain a static electric charge. Objects made of non-conductive materials (e.g., plastics) easily accumulate and retain static electric charge, as can objects made of conductive material (e.g., metal, water) if they are not electrically grounded. The static electric charge on an object, such as a human body or plastic fuel tank/container, can reach as high as several thousand volts!

A static electric spark can be generated if the static electric charge stored on an object "jumps" to another, less charged object. Such a spark can ignite invisible gasoline vapors that are present during fueling situations.

Typical sources of static electric hazards during fueling

The following objects can accumulate a static electric charge and cause an ignition spark in typical fueling situations:

Ungrounded tanks/containers. Any ungrounded fuel tank or container can accumulate a static electric charge as a result of contact with other objects or friction during transportation. This static electricity can discharge as a spark to the grounded gasoline dispenser nozzle, as the nozzle is first brought close to the tank/container at the beginning of the fueling process.

Flowing gasoline. Most people are not aware that gasoline accumulates static electric charge while flowing through a hose or pipe. This charge then transfers to and accumulates in the gasoline tank or container that is being filled. The total amount of charge accumulation depends on the amount of gasoline pumped into the container, the speed with which it is pumped, and whether or not the tank/container is grounded. If sufficient static electric charge accumulates in the fuel tank or container during the fueling process, the tank/container may discharge a spark to the grounded gasoline dispenser nozzle.

Persons. A person dispensing the gasoline can carry a static electric charge on their body, typically resulting from contact with their car seat or electronics. The static electricity can discharge as a spark between that person's hand and either the grounded dispenser nozzle or the fuel tank opening.

HBHR350GX & HBHR280GX Exploded View – Rev A

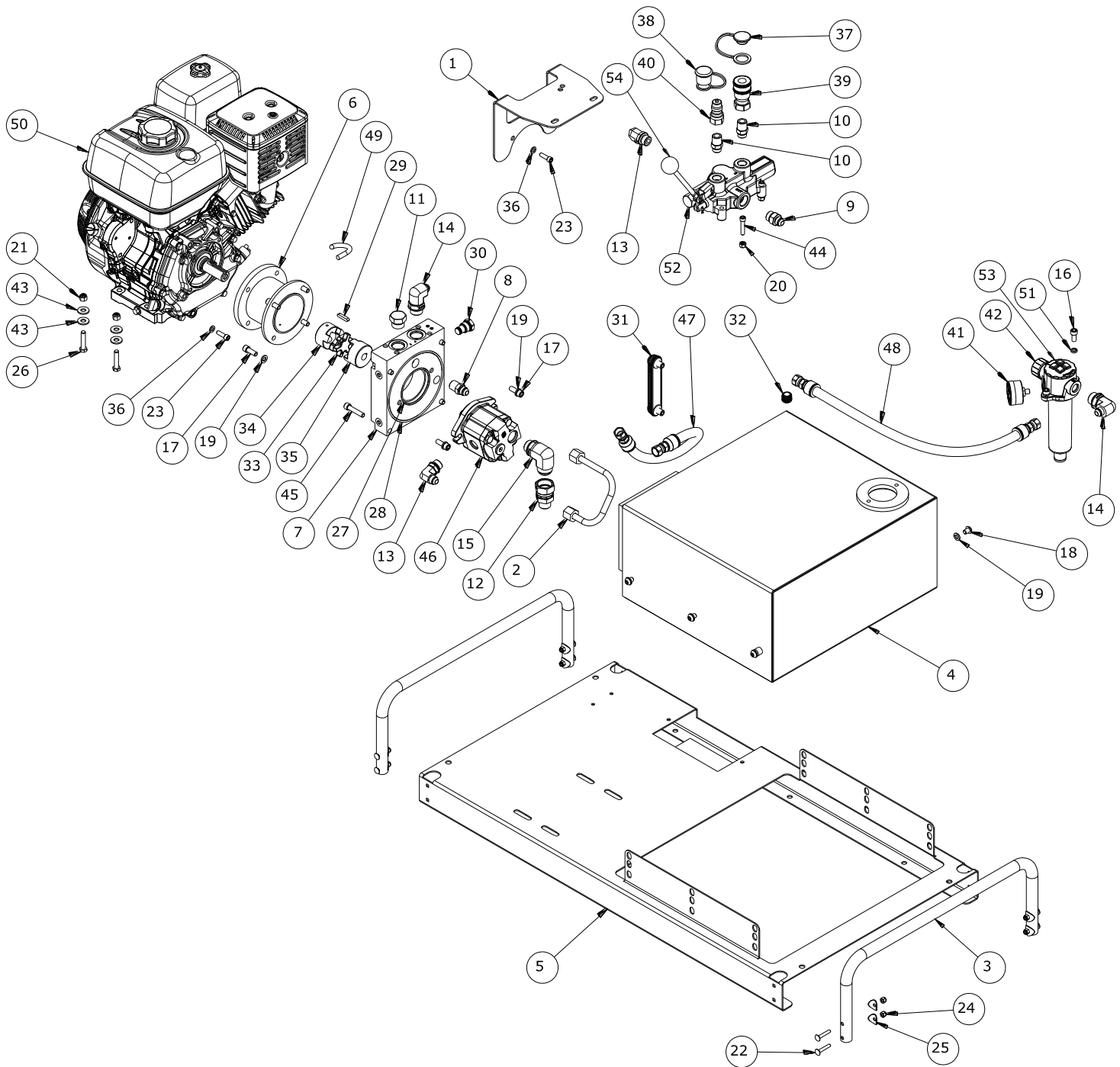

HBHR350GX & HBHR280GX Parts List - Rev A

Ref #	Part	Description	Qty	Used On
1	1010330	LS-3000/ RD2500 BRACKET, MODULAR POWER UNIT	1	ALL
2	1010353	TUBE, -8 FJIC X -8 FJIC ASM	1	ALL
3	1010427	GRAB HANDLE, HPU	2	HBHR350GX
	1010264	GRAB HANDLE, HPU	2	HBHR280GX
4	1010433	WELDMENT, HPU RES-15	1	HBHR350GX
	1010249	WELDMENT, HPU RES-8	1	HBHR280GX
5	1010435	WELDMENT, BASE, HPU RES-15	1	HBHR350GX
	1010419	WELDMENT, BASE, HPU RES-8	1	HBHR280GX
6	1010464	HONDA/SUBARU ENGINE COUPLING, MODULAR POWER	1	ALL
7	1012902	ASSY, PUMP HEAD ASSM, HPU MODULAR SAE-A	1	ALL
8	1013178	08 Male JIC X -08 Male NPT	1	ALL
9	1013939	FITTING STRAIGHT -8 MJIC X -10 MORB	1	ALL
10	1014003	#08 Male ORB X 1/2 Male NPT	2	ALL
11	1014103	HEX PLUG, -12 MORB	1	ALL
12	1014236	FEMALE -16 JIC X MALE -12 NPT ADAPTER	1	ALL
13	1014312	FITTING 90 DEG -8 MJIC / -10 MORB	2	ALL
14	1014313	FITTING 90 DEG -8 MJIC / -12 MORB	2	ALL
15	1014328	FITTING 90 DEG -16 MJIC X -12 MORB	1	ALL
16	1014938	3/8"-16 x 3/4" SHCS BLACK OXIDE	2	ALL
17	1014939	3/8"-16 x 1" SHCS BLACK OXIDE	6	ALL
18	1014952	3/8"-16 x 1/2" BHCS BLACK OXIDE	6, 4	HBHR350GX, HBHR280GX
19	1014971	3/8" SCREW SIZE LOCK WASHER, ZINC	12, 10	HBHR350GX, HBHR280GX
20	1014985	5/16"-18 NYLON-INSERT HEX LOCK NUT, GR2, ZINC	3	ALL
21	1014986	3/8"-16 NYLON-INSERT HEX LOCK NUT, GR5, ZINC	4	ALL
22	1015055	1/4"-20 x 1-1/2" CARRIAGE BOLT, ZINC	8	ALL
23	1015063	5/16"-24 x 1" SHCS BLACK OXIDE	4	ALL
24	1015073	1/4"-20 NYLON-INSERT HEX LOCK NUT, GR2, ZINC	8	ALL
25	1015194	1/4" SCREW SIZE CURVED WASHER FOR 1" TUBE, ZINC	8	ALL
26	1015206	3/8"-16 x 1-3/4" HHCS, GR5, ZINC	4	ALL
27	1023992	O-RING / OLD #8152	1	ALL
28	1024201	O-RING / OLD #138	1	ALL
29	1037197	1/4 X 1/4 X 1-1/4 Steel Key	1	HBHR350GX
30	1058437	CP10-20-N, CAVITY PLUG	1	ALL
31	1102641	5" SIGHT GAUGE	1	ALL
32	1067976	PLUG, MAGNETIC ALLEN HEAD, 1/2"-14 NPTF, STL	1	ALL
33	1068113	SOX SPACER SPIDER, 68514411070	1	ALL
34	1068117	L095 HUB, 1" BORE, 1/4" x 1/8" KEYWAY	1	ALL
35	1068125	L095 HUB, 5/8" BORE, 5/32" x 5/64" KEYWAY	1	ALL
36	1080421	5/16" SCREW SIZE LOCK WASHER, ZINC	4	ALL
37	1081058	1/2 BODY DUST PLUG WITH RUBBER STRAP NEW STYLE	1	ALL
38	1081070	1/2 DUST CAP NEW STYLE	1	ALL
39	1085800	F.bir 12 NPT - 1/2" NPT Coupler	1	ALL
40	1085801	M.bir 12 NPT - 1/2" NPT Tip	1	ALL
41	1086823	0-60 PSI Bypass Gauge - 1/8 NPT	1	ALL
42	1090366	25GPM TANK TOP FILTER HEAD (includes filter)	1	ALL
	1090490	10 Micron Filter Element (only)	1	ALL
43	1091091	3/8" FLAT WASHER, USS, ZINC	8	ALL
44	1094966	5/16"-18 x 1-1/2" SHCS BLACK OXIDE	3	ALL
45	1120799	3/8"-16 x 1-3/4" SHCS BLACK OXIDE	4	ALL
46	1124188	.51CID 2 BLT A 5/8 KEYED CW DUAL #12 X #10 PORTS	1	HBHR350GX
	1124173	.36CID 2 BLT A 5/8 KEYED CW DUAL #12 X #10 SIDE/REAR	1	HBHR280GX
47	1157987	EC21508-08Z-608-608-18.5 OAL	1	HBHR350GX
	1157987	EC21508-08Z-608-608-18.5 OAL	1	HBHR280GX
48	1157988	EC21508-08Z-608-608-24.5 OAL	1	HBHR350GX
	1157987	EC21508-08Z-608-608-18.5 OAL	1	HBHR280GX
49	1158867	OIL DRAIN EXTENSION HOSE, 12mm	1	ALL
50	1158869	HONDA GX390, RECOIL ONLY	1	HBHR350GX
	1158864	ENGINE, HONDA GX240, ELECTRIC START	1	HBHR280GX
51	1158954	3/8" HIGH COLLAR LOCK WASHER, ZINC	2	ALL
52	1159418	SINGLE SPOOL MONO-BLOCK 20 GPM (PRINCE)	1	ALL
53	1162902	Filter Head Cap	1	ALL
54	1082100	Valve Handle	1	ALL

HBHS300GX & HBHS310GX Exploded View – Rev A

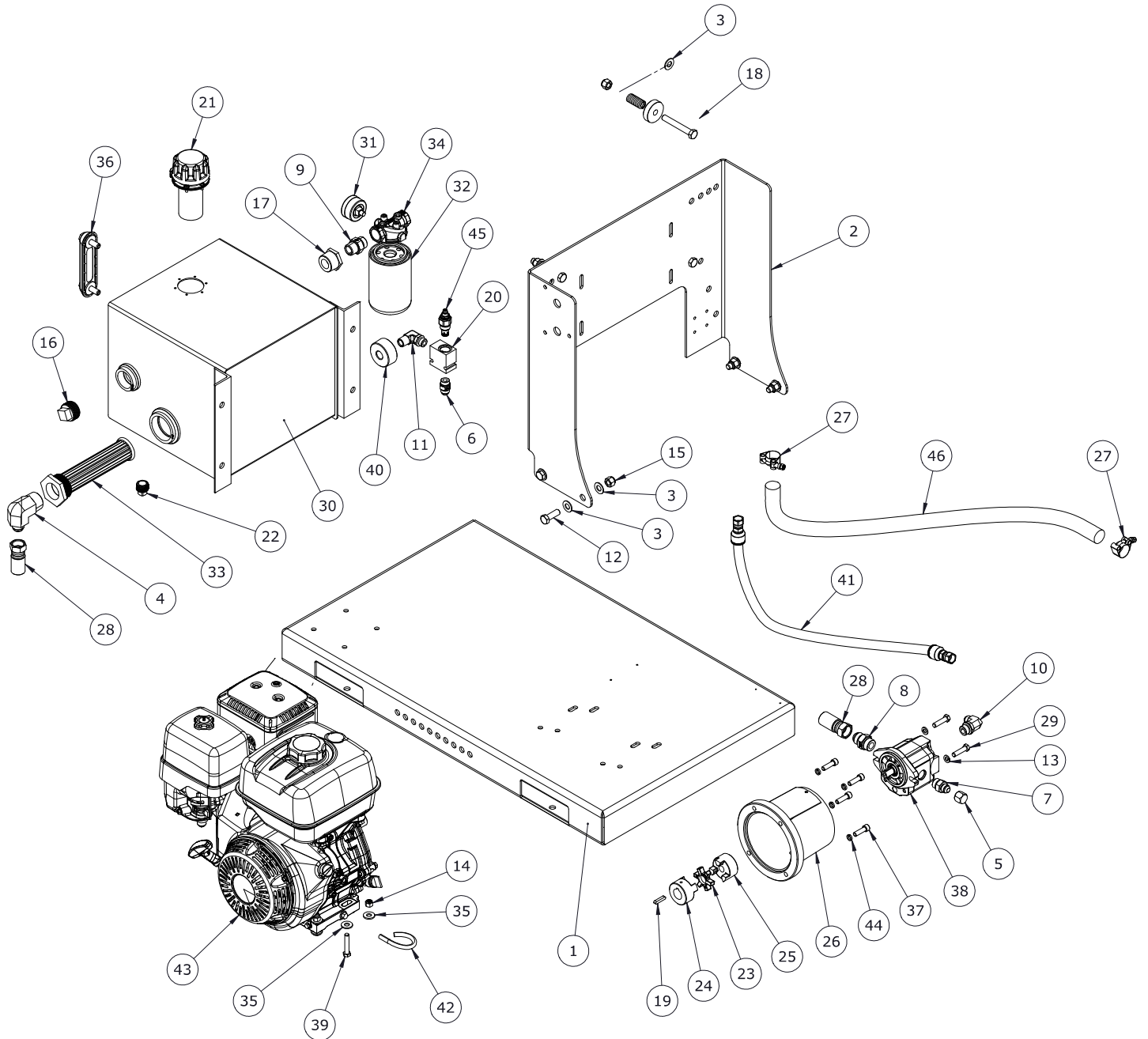

HBHS300GX & HBHS310GX Parts List - Rev A

Ref #	Part	Description	Qty	Used On
1	1010412	FFP, FORMED SHEET, POWER UNIT SKIDFRAME BASE, PC	1	ALL
2	1010413	FFP, FORMED SHEET, POWER UNIT SKIDFRAME UPRIGHT	1	ALL
3	1011765	1/2" SCREW SIZE FLAT WASHER, STEEL	12	ALL
4	1013333	FITTING, ELBOW, -12 MJIC x 1-1/4" MNPT	1	ALL
5	1013500	FITTING CAP -8 JIC	1	ALL
6	1013938	FITTING STRAIGHT -8 MJIC X -8 MORB	1	ALL
7	1013939	FITTING STRAIGHT -8 MJIC X -10 MORB	1	ALL
8	1013952	FITTING STRAIGHT -12 MJIC X -12 MORB	1	ALL
9	1014008	FITTING STRAIGHT -12 MORB x 3/4" MP	1	ALL
10	1014312	FITTING 90 DEG -8 MJIC / -10 MORB	1	ALL
11	1014425	FITTING 90 DEG -8 MORB / -8 MP	1	ALL
12	1014905	1/2"-13 x 1-1/2" HHCS, GR5, ZINC	4	ALL
13	1014971	3/8" SCREW SIZE LOCK WASHER, ZINC	2	ALL
14	1014986	3/8"-16 NYLON-INSERT HEX LOCK NUT, GR5, ZINC	4	ALL
15	1014987	1/2"-13 NYLON-INSERT HEX LOCK NUT, 18-8 STAINLESS	8	ALL
16	1030822	1-1/4 SQUARE-HEAD PLUG	1	ALL
17	1030832	1-1/4 x 3/4 - HEXBUSH	1	ALL
18	1031121	MOUNTING KIT FOR UPRIGHT RES.	1	ALL
19	1037197	1/4 X 1/4 X 1-1/4 Steel Key	1	ALL
20	1046260	2-WAY BODY, SAE -8 PORTS - ALUMINUM	1	ALL
21	1067914	FILLER/BREATHER, 40 MICRON, SS MESH	1	ALL
22	1067982	PLUG, MAGNETIC SQUARE HEAD, 3/4"-14 NPTF, STL	1	ALL
23	1068113	SOX SPACER SPIDER, 68514411070	1	ALL
24	1068117	L095 HUB, 1" BORE, 1/4" x 1/8" KEYWAY	1	ALL
25	1068125	L095 HUB, 5/8" BORE, 5/32" x 5/64" KEYWAY	1	ALL
26	1068422	PUMP BRACKET	1	ALL
27	1069273	Hc-70 Hose Clamp 1.12" To 1.25"	2	ALL
28	1072535	3/4" Straight JIC Female Swivel	2	ALL
29	1080381	3/8"-16 x 1-1/2" MODIFIED HHCS, GR5, ZINC	2	ALL
30	1086461	WELDMENT, RES-10, PC	1	ALL
31	1087964	GAUGE, FILTER INDICATOR, 0-60 PSI	1	ALL
32	1090169	10 Micron Cellulose Spin On Ae10 Plain Can No Logo	1	ALL
33	1090428	STRAINER, 2" NPTF MALE THREAD, 1-1/4" NPTF OUTLET	1	ALL
34	1090478	#12 SAE SPIN ON FILTER HEAD	1	ALL
35	1091091	3/8" FLAT WASHER, USS, ZINC	8	ALL
36	1102641	5" SIGHT/TEMP GAUGE, M12x1.75, PLASTIC GUARD	1	ALL
37	1115360	3/8"-16 x 1-1/4" SHCS BLACK OXIDE	4	ALL
38	1124173	.36CID 2 BLT A 5/8 KEYED CW DUAL #12 X #10 PORTS	1	HBHS300GX
	1124188	.51cid 2 Blt A 5/8 Keyed CW Dual #12 X #10 Side/Rear Ports	1	HBHS310GX
39	1124332	3/8"-16 x 2" HHCS, GR5, ZINC	4	ALL
40	1157513	REDUCER, 2" MNPT X 1/2" FNPT, HEX, BLK STEEL	1	ALL
41	1157974	EC21508-08Z-608-608-45 OAL	1	ALL
42	1158867	OIL DRAIN EXTENSION HOSE, 12mm	1	ALL
43	1158869	HONDA GX390, RECOIL ONLY	1	ALL
44	1158954	3/8" HIGH COLLAR LOCK WASHER, ZINC	4	ALL
45	1159419	Relief Valve - Pilot Operated – 3000 PSI	1	HBHS300GX
	1159421	Relief Valve - Pilot Operated – 2000 PSI	1	HBHS310GX
46	1159422	3/4" Suction Hose Eaton Puma Hose	1	ALL

HBHS600GXE, HBHS610GXE, & HBHS620GXE Exploded View – Rev A

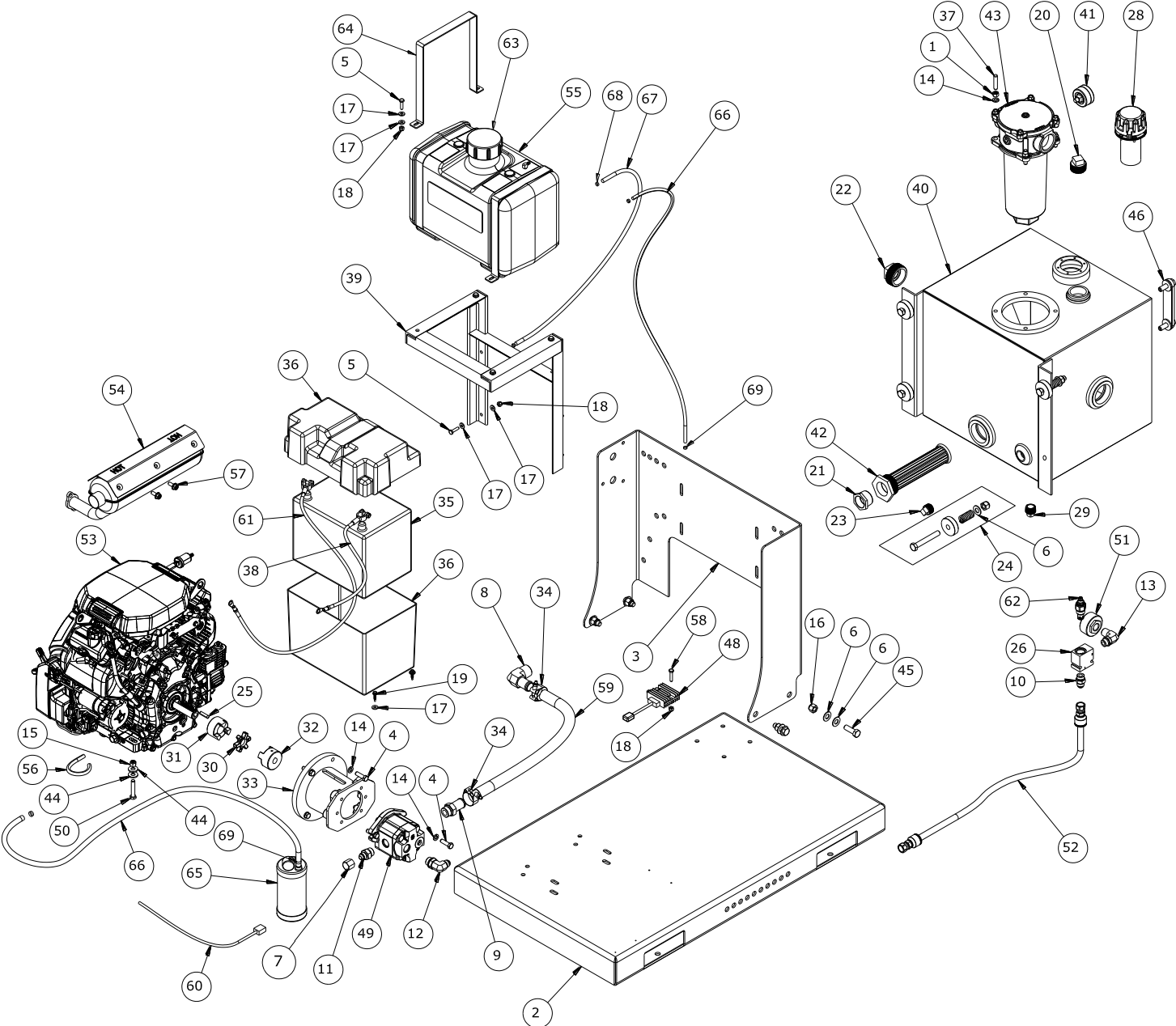

HBHS600GXE, HBHS610GXE, & HBHS620GXE Parts List - Rev A

Ref #	Part	Description	Qty	Used On
1	1010303	3/8"-16 HEX NUT, GR5, ZINC	4	ALL
2	1010412	FFP, FORMED SHEET, POWER UNIT SKIDFRAME BASE, PC	1	ALL
3	1010413	FFP, FORMED SHEET, POWER UNIT SKIDFRAME UPRIGHT, PC	1	ALL
4	1010572	3/8"-16 x 1-1/4" HHCS, GR5, ZINC	6	ALL
5	1011119	1/4"-20 x 1" HHCS, GR5, ZINC	8	ALL
6	1011765	1/2" SCREW SIZE FLAT WASHER, STEEL	12	ALL
7	1013500	ADAPTER CAP NUT 3/4 X 16 JIC FOR TUBE OD 1/2"	1	ALL
8	1013618	ADAPTER 90 DEG ELBOW, MHB X MNPT, STEEL	1	ALL
9	1013649	ADAPTER STRAIGHT 1" MALE HOSE NIPPLE X 1-1/16 X 12 MALE ORB	1	ALL
10	1013938	08 MALE JIC X #08 MALE ORB	1	ALL
11	1013939	08 MALE JIC X #10 MALE ORB	1	ALL
12	1014312	ADAPTER 90 DEG ELBOW 3/4 X 16 MALE JIC X 7/8 X 14 MALE ORB	1	ALL
13	1014425	ADAPTER 90 DEG ELBOW 3/4 X 16 MALE ORB X 1/2" MALE NPT	1	ALL
14	1014971	3/8" SCREW SIZE LOCK WASHER, ZINC	10	ALL
15	1014986	3/8"-16 NYLON-INSERT HEX LOCK NUT, GR5, ZINC	4	ALL
16	1014987	1/2"-13 NYLON-INSERT HEX LOCK NUT, 18-8 STAINLESS	8	ALL
17	1015046	1/4" FLAT WASHER, GENERAL PURPOSE, ZINC	20	ALL
18	1015073	1/4"-20 NYLON-INSERT HEX LOCK NUT, GR2, ZINC	10	ALL
19	1015115	#12-14 x 1" SELF DRILLING SCREW, UNSLOTTED HEX WASHER	4	ALL
20	1030822	1-1/4 SQUARE-HEAD PLUG	1	ALL
21	1030828	1-1/4 x 1 - HEXBUSH	1	ALL
22	1030867	2 NPT SQUARE-HEAD PLUG	1	ALL
23	1030883	3/4 PLUG, BLACK STEEL	1	ALL
24	1031121	MOUNTING KIT FOR 50 GALLON UR-50-MK UPRIGHT RES	4	ALL
25	1037197	1/4 X 1/4 X 1-1/4 STEEL KEY	1	ALL
26	1046260	STANDARD BODY, C10-2 SAE-8 PORTS	1	ALL
28	1067914	FILLER/BREATHER, 40 MICRON, SS MESH	1	ALL
29	1067982	PLUG, MAGNETIC SQUARE HEAD, 3/4"-14 NPTF, STL	1	ALL
30	1068112	HYTREL SPACER SPIDER 68514425310	1	ALL
31	1068117	L095 HUB, 1" BORE, 1/4" x 1/8" KEYWAY	1	ALL
32	1068125	L095 HUB, 5/8" BORE, 5/32" x 5/64" KEYWAY	1	HBHS600GXE, HBHS610GXE
	1068122	L095 HUB, 3/4" BORE, 3/16" x 3/32" KEYWAY	1	HBHS620GXE
33	1068417	PUMP/ENGINE MOUNT, SAE A, 5" LENGTH (MAGNALOY)	1	ALL
34	1069269	HC-100 1" T-BOLT HOSE CLAMP	2	ALL
35	1073513	BATTERY, 35/75, 450 CCA	1	ALL
36	1074713	BATTERY BOX, HM300BK, GROUP 24	1	ALL
37	1080381	3/8"-16 x 1-1/2" MODIFIED HHCS, GR5, ZINC	4	ALL
38	1083941	4 GA BATTERY CABLE "BLACK" 20" LONG W/ENDS	1	ALL
39	1086154	WELDMENT, TANK MOUNTING BRACKET	1	ALL
40	1086478	WELDMENT, HYDRAULIC TANK 20 GAL WITH FILTER HOLE	1	ALL
41	1087964	GAUGE, FILTER INDICATOR, 0-60 PSI	1	ALL
42	1090428	STRAINER, 2" NPTF MALE THREAD, 1-1/4" NPTF OUTLET PORT	1	ALL
43	1090443	SUCTION / RETURN LINE TANK TOP FILTER (ZINGA)	1	ALL
	1090368	Filter Element (only)	1	ALL
44	1091091	3/8" FLAT WASHER, USS, ZINC	8	ALL
45	1096207	1/2"-13 x 1-1/2" HHCS, GR8, ZINC	4	ALL
46	1102641	5" SIGHT GAUGE	1	ALL
47	1112688	1/2"-13 x 3-1/2" HHCS, GR8, ZINC	4	ALL
48	1117685	REGULATOR/RECTIFIER	1	ALL
49	1124189	.66CID 2 BLT A 5/8 KEYED CW DUAL #12X#10 SIDE/REAR PORTS	1	HBHS600GXE
	1124190	.88CID 2 BLT A 5/8 KEYED CW DUAL #12X#10 SIDE/REAR PORTS	1	HBHS610GXE
	1124161	1.02CID 2 BLT A 3/4 KEYED CW DUAL #12X#10 SIDE/REAR PORTS	1	HBHS620GXE
50	1124332	3/8"-16 x 2" HHCS, GR5, ZINC	4	ALL
51	1157513	REDUCER, 2" MNPT X 1/2" FNPT, HEX, BLK STEEL	1	ALL
52	1157973	EC21508-08Z-608-608-36 OAL	1	ALL
53	1158881	ENGINE, 22.1 HP (HONDA)	1	ALL
54	1158883	MUFFLER FOR GX630	1	ALL
55	1158884	FUEL TANK KIT, 5 GAL, FOR GX 630	1	ALL
56	1158888	OIL DRAIN EXTENSION HOSE, 20 MM	1	ALL
57	1158898	M8-1.25 X 20 HEX FLANGE BOLT, ZINC	2	ALL
58	1158979	1/4"-20 x 1" HHCS, 18-8 STAINLESS	2	ALL
59	1159247	1" SUCTION HOSE	1	ALL
60	1159249	RECTIFIER ELECTRICAL HARNESS	1	ALL
61	1159251	34".4 GAUGE, POSITIVE BATTERY CABLE, LUG & CLAMP W/TERMINAL	1	ALL
62	1159419	CART, P.O. RELIEF VALVE	1	HBHS600GXE
	1159420	CART, P.O. RELIEF VALVE	1	HBHS610GXE
	1159421	CART, P.O. RELIEF VALVE	1	HBHS620GXE
63	080175AE	Fuel Tank Cap	1	ALL
64	468975A	Fuel Tank Strap	2	ALL
65	468888A	Carbon Canister	1	ALL
66	468894A	Carbon Canister Hose	2	ALL
67	468851A	Fuel Hose	1	ALL
68	468898A	Fuel Hose Clamp	2	ALL
69	468850A	Carbon Canister Hose Clamp	4	ALL

Limited Warranty Policy

Dear Valued Customer:

The Brave product you just purchased is built with the finest material and craftsmanship. Use this product properly and enjoy the benefits from its high performance. By purchasing a Brave product, you show a desire for quality and durability. Like all mechanical equipment this unit requires a due amount of care. Treat this unit like the high quality piece of machinery it is. Neglect and improper handling may impair its performance.

Thoroughly read the instructions and understand the operation before using your product. Always contact Brave Product Support at 1-800-350-8739 prior to having any service or warranty work performed, as some services performed by parties other than Brave approved service centers may void this warranty. This limited warranty is in lieu of any other warranty expressed or implied, written or oral and Brave assumes no other responsibility or liability outside that expressed within this limited warranty.

Limited Warranty for Brave and Brave Pro Hydra Buddy Models:

HBHR280GX
HBHS310GXE

HBHR350GX
HBHS600GXE
HBHS620GXE

HBHS300GX
HBHS610GXE

	Consumer Warranty Period	Commercial Warranty Period
Weldments		
	2 years from date of purchase by user	2 year from date of purchase by user
Valves and Pumps		
	2 years from date of purchase by user	1 year from date of purchase by user
Wear Parts	In addition to the normal warranty, Brave shall warrant some normal wear items from defects in material or workmanship for a period of 30 days from the date of purchase by user. Normal wear items covered under this warranty are limited to: clamps, couplers, filters, mounts, hoses, hardware. Routine maintenance items such as lubricants, clutch adjustments, tune ups are not covered under warranty.	
Engines	The engine warranty is covered under the terms and conditions as outlined by the engine manufactures warranty contained herein and is the sole responsibility of the engine manufacturer. Normal engine maintenance such as spark plugs, oil changes, air filters, adjustments, fuel system cleaning and obstruction due to build up is not covered by this Brave limited warranty.	

“Consumer use” means personal residential household use by a consumer. **“Commercial use”** means all other uses, including, but not limited to, use for commercial, income producing or rental purposes or when purchased by a business.

This limited warranty applies to the original purchaser of the equipment (verification of purchase, in the form of a receipt, is the responsibility of the buyer), is non-transferable, and covers parts and labor. Parts will be replaced or repaired at no charge, except when the equipment has failed due to lack of proper maintenance. If a part is no longer available, the part may be replaced with a similar part of equal function. Any misuse, abuse, alteration or improper installation or operations will void warranty. Determining whether a part is to be replaced or repaired is the sole decision of Brave. Brave will not provide for replacement of complete products due to defective parts. Any costs incurred due to replacement or repair of items outside of a Brave approved facility is the responsibility of the buyer and not covered under warranty. Transportation costs to and from service center and/or service calls are the responsibility of the customer.

This limited warranty specifically excludes the following; failure of parts due to damage caused by accident, fire, flood, windstorm, acts of God, applications not approved by Brave in writing, corrosion caused by chemicals, use of replacement parts which do not conform to manufacturer’s specifications, damage related to rodent and/or insect infestation and damage caused by vandalism. Additional exclusions: loss of running time, inconvenience, loss of income, or loss of use, including any implied warranty of merchantability of fitness for a specific use. Also, outdoor power equipment needs periodic parts and service to perform well, and this limited warranty does not cover instances when normal use has exhausted the life of a component or the engine.

This limited warranty does not cover any personal injury or damage to surrounding property caused by failure of any part, misuse or inability to use the product. Alteration of the product, including safety features, shall void this limited warranty.

Repair or replacement of parts does not extend the warranty period. This limited warranty gives you specific legal rights. You may also have other rights that vary by state.

Please have model number, item number and serial number on hand prior to making a warranty claim or inquiry.

This page has intentionally been left blank.



Brave Product Registration Form

Your Information

Full Name: _____
Last First M.I.

Address: _____
Street Address Apartment/Unit #

_____ City State ZIP Code

Home Phone: _____ Alternate Phone: _____

Email Address: _____

Purchased From

Company: _____

Address: _____
Street Address Apartment/Unit #

_____ City State ZIP Code

Model Information

Purchase Date: _____

Application Type: Homeowner Commercial Rental

Model (*i.e.* HBHR350GX)

Serial # (*i.e.* HBHR350GXA01234567)

Signature: _____



WARNING: This product can expose you to chemicals including soots, tars, and mineral oils, which are known to the State of California to cause cancer, and carbon monoxide, which is known to the State of California to cause birth defects or other reproductive harm. For more information go to www.P65Warnings.ca.gov.

BRAVE

HYDRA BUDDY™

20195 S. Diamond Lake Rd, Ste 100
Rogers, MN 55374
1-800-350-8739