

Owner's Manual

Spark-Ignited Stationary Generators

Residential and Commercial

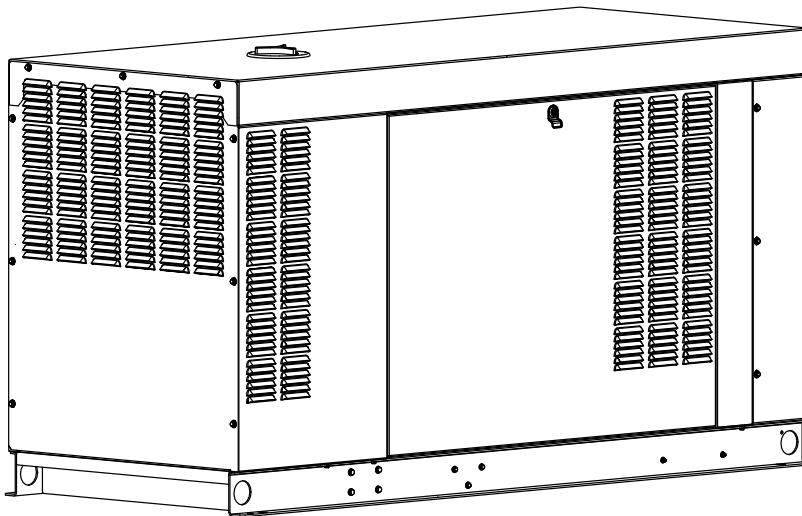

48 kW	4.5L
60 kW	4.5L
80 kW	4.5L



WARNING

Loss of life. This product is not intended to be used in a critical life support application. Failure to adhere to this warning could result in death or serious injury. (000209b)

Register your Generac product at:
WWW.GENERAC.COM
1-888-GENERAC
(888-436-3722)

Para español , visita: <http://www.generac.com/service-support/product-support-lookup>

Pour le français, visiter : <http://www.generac.com/service-support/product-support-lookup>

SAVE THIS MANUAL FOR FUTURE REFERENCE

Use this page to record important information about the generator.

For quick and easy reference, copy the information printed on the Unit Identification Label onto the sample label printed here. The Unit Identification Label is located on the base frame adjacent to the front engine mount on all models.

Always provide the complete model number and serial number when contacting an Independent Authorized Service Dealer (IASD) about parts and/or service.

Operation and Maintenance: Correct maintenance and care of the unit ensures a minimum number of problems, and keeps operating expenses at a minimum. It is the operator's responsibility to perform all safety inspections, to verify all maintenance for safe operation is performed promptly, and to have the equipment inspected periodically by an IASD. Normal maintenance, service, and replacement of parts are the responsibility of the owner/operator and are not considered defects in materials or workmanship within the terms of the warranty. Individual operating habits and usage may contribute to the need for additional maintenance or service.

When the generator requires servicing or repairs, Generac recommends contacting an IASD for assistance. Authorized service technicians are factory-trained and are capable of handling all service needs. To locate the nearest IASD, please visit the dealer locator at:

www.generac.com/Dealer-Locator.

**INDEPENDENT AUTHORIZED
SERVICE DEALER LOCATION**

To locate the nearest
INDEPENDANT AUTHORIZED SERVICE
DEALER,
please call this number:
1-800-333-1322

or visit the dealer locator at:
www.generac.com/Service/DealerLocator/

<u>GENERATOR UNIT</u>			
GEN MODEL:			
MODEL:			
SERIAL:			
ALTERNATE			
PROD DATE:			
COUNTRY OF ORIGIN:			
<u>GENERATOR DATA</u>			
KW	KVA	HZ	PF
UPSIZE ALT	KW	KVA	
VOLT	/	AMP	
ENG RPM	ALT RPM		
BREAKER	KW	AMP	
X"D		X"D	
ROTOR	STATOR	CLASS	
WINDINGS @	AMBIENT TEMP		
		MANUF. LOC	

003564

Figure 1-1. Sample Label

WARNING

CANCER AND REPRODUCTIVE HARM

www.P65Warnings.ca.gov

(000393a)

Table of Contents

Section 1: Safety Rules & General Information

Introduction	1
Read This Manual Thoroughly	1
Safety Rules	1
How to Obtain Service	1
General Hazards	2
Exhaust Hazards	2
Fire Hazards	2
Electrical Hazards	3
Explosion Hazards	3
Battery Hazards	4

Section 2: General Information

Emissions	5
Emissions Data Plate	5
Specifications	5
Engine Oil Recommendations	6
Weather and Maintenance Kits	6
Coolant Water Treatment	6
Fuel Requirements	7
Reconfiguring the Fuel System	7
Change Fuel Selection	7
Battery Requirements	7
Battery Charger	7
Battery Safety Precautions	8
Corrosion Protection	8

Section 3: Activation and Startup

Orientation	9
Removing the Side Access Panels	9
Installing the Battery	9
Opening the Viewing Window	10
Activating the Unit	11
Starting and Running Engine	12
Operational Checks	13
Self Test	13
Checking Manual Transfer Switch Operation ..	13
Electrical Checks	13
Testing Generator Under Load	14

Testing Auxiliary Shutdown Switch Operation	14
Checking Automatic Operation	15

Securing the Generator

Section 4: Operation

Control Panel	17
AUTO/MANUAL/OFF	18
Menu Navigation	18
Alarm/Warning Conditions	19
Changing Date/Time	20
Programmable Timers	20
Dealer Programmable	20
User Programmable	20
USB Port for Firmware Updates	20
Battery Charger	21
Transfer Switch Automatic Operation	21
Automatic Sequence of Operation	21
Transfer Switch Manual Operation	22
Transfer to Generator Power	22
Transfer Back to Utility Power	22

Section 5: Maintenance

Component Locations	23
Access Panels	24
Removal	24
Installation	24
Maintenance	24
Service Maintenance Schedule	25
Remove From Service	26
25 Hour Break-In	26
Daily Maintenance	26
Schedule A Maintenance	27
Schedule A Maintenance Item Locations	27
Preliminary Instructions	27
Inspecting the Enclosure Louvers	27
Inspecting the Fuel Lines	27
Inspecting Coolant Level and Hoses	27
Inspecting Radiator for Clogging	27
Checking Lubricating Oil Level and Drain Hose	28
Replacing Lubricating Oil and Oil Filter	28
Checking Battery Condition/Fluid Level	29
Inspecting Accessory/Drive Belt	30

Replacing Air Filter Element	31
Final Instructions	31
Schedule B Maintenance	32
Schedule B Maintenance Item Locations	32
Draining and Flushing Coolant System	32
Clean/Gap/Replace Spark Plugs	33
Final Instructions	33
Schedule C Maintenance	34
Return To Service	34
 <i>Section 6: Troubleshooting</i>	
Engine Troubleshooting	35
Controller Troubleshooting	36
Removal From Service During Utility Outage .	37
Return to Service During Utility Outage	37
Storage	37
Prepare For Storage	37
Battery Removal	38
Return From Storage	38
Attention After Submersion	38

Section 1: Safety Rules & General Information

Introduction

Thank you for purchasing this compact, high performance, liquid-cooled, engine-driven generator. It is designed to automatically supply electrical power to operate critical loads during a utility power failure.

This unit is factory installed in an all-weather enclosure intended exclusively for outdoor installation. This generator will operate using either vapor withdrawn liquid propane (LP gas) or natural gas (NG).

NOTE: This generator is suitable for supplying typical residential/commercial loads, such as induction motors (sump pumps, refrigerators, freezers, air conditioners, furnaces, etc.), electronic components (computers, monitors, televisions, etc.), lighting, microwaves, and other residential and business loads, when sized correctly.

The information in this manual is accurate based on products produced at the time of publication. The manufacturer reserves the right to make technical updates, corrections, and product revisions at any time without notice.

Read This Manual Thoroughly



WARNING

Consult Manual. Read and understand manual completely before using product. Failure to completely understand manual and product could result in death or serious injury. (000100a)

If any section of this manual is not understood, contact the nearest Independent Authorized Service Dealer (IASD) or Generac Customer Service at 1-888-436-3722 (1-888-GENERAC), or visit www.generac.com for starting, operating, and servicing procedures. The owner is responsible for proper maintenance and safe use of the unit.

SAVE THESE INSTRUCTIONS for future reference. This manual contains important instructions that must be followed during placement, operation, and maintenance of the unit and its components. Always supply this manual to any individual that will use this unit, and instruct them on how to correctly start, operate, and stop the unit in case of emergency.

Safety Rules

The manufacturer cannot anticipate every possible circumstance that might involve a hazard. The alerts in this manual, and on tags and decals affixed to the unit, are not all inclusive. If using a procedure, work method, or

operating technique that the manufacturer does not specifically recommend, verify that it is safe for others and does not render the equipment unsafe.

Throughout this publication, and on tags and decals affixed to the unit, DANGER, WARNING, CAUTION, and NOTE blocks are used to alert personnel to special instructions about a particular operation that may be hazardous if performed incorrectly or carelessly. Observe them carefully. Alert definitions are as follows:

DANGER

Indicates a hazardous situation which, if not avoided, will result in death or serious injury.

(000001)

WARNING

Indicates a hazardous situation which, if not avoided, could result in death or serious injury.

(000002)

CAUTION

Indicates a hazardous situation which, if not avoided, could result in minor or moderate injury.

(000003)

NOTE: Notes contain additional information important to a procedure and will be found within the regular text of this manual.

These safety alerts cannot eliminate the hazards that they indicate. Common sense and strict compliance with the special instructions while performing the action or service are essential to preventing accidents.

How to Obtain Service

When the unit requires servicing or repairs, contact Generac Customer Service at 1-888-GENERAC (1-888-436-3722) or visit www.generac.com for assistance.

When contacting Generac Customer Service about parts and service, always supply the complete model and serial number of the unit as given on its data decal located on the unit. Record the model and serial numbers in the spaces provided on the front cover of this manual.

General Hazards

⚠ DANGER

Loss of life. Property damage. Installation must always comply with applicable codes, standards, laws and regulations. Failure to do so will result in death or serious injury. (000190)



⚠ WARNING

Loss of life. This product is not intended to be used in a critical life support application. Failure to adhere to this warning could result in death or serious injury. (000209b)

⚠ WARNING

Equipment damage. This unit is not intended for use as a prime power source. It is intended for use as an intermediate power supply in the event of temporary power outage only. Doing so could result in death, serious injury, and equipment damage. (000247a)

⚠ WARNING

Electric shock. Only a trained and licensed electrician should perform wiring and connections to unit. Failure to follow proper installation requirements could result in death, serious injury, and equipment or property damage. (000155a)



⚠ WARNING

Moving Parts. Keep clothing, hair, and appendages away from moving parts. Failure to do so could result in death or serious injury. (000111)



⚠ WARNING

Moving Parts. Do not wear jewelry when starting or operating this product. Wearing jewelry while starting or operating this product could result in death or serious injury. (000115)

⚠ WARNING

Risk of injury. Do not operate or service this machine if not fully alert. Fatigue can impair the ability to service this equipment and could result in death or serious injury. (000215)

⚠ WARNING

Accidental Start-up. Disconnect the negative battery cable, then the positive battery cable when working on unit. Failure to do so could result in death or serious injury. (000130)

⚠ WARNING

Injury and equipment damage. Do not use generator as a step. Doing so could result in falling, damaged parts, unsafe equipment operation, and could result in death or serious injury. (000216)

Inspect the generator regularly, and contact an IASD for parts needing repair or replacement.

Exhaust Hazards



⚠ DANGER

Asphyxiation. Running engines produce carbon monoxide, a colorless, odorless, poisonous gas. Carbon monoxide, if not avoided, will result in death or serious injury. (000103)



⚠ DANGER

Asphyxiation. Carbon monoxide can kill in minutes. Operate this unit outdoors only. Failure to do so will cause death or serious injury. (000525)



⚠ WARNING

Asphyxiation. Always use a battery operated carbon monoxide alarm indoors and installed according to the manufacturer's instructions. Failure to do so could result in death or serious injury. (000178a)

⚠ WARNING

Equipment and property damage. Do not alter construction of, installation, or block ventilation for generator. Failure to do so could result in unsafe operation or damage to the generator. (000146)

Fire Hazards



⚠ WARNING

Fire hazard. Do not obstruct cooling and ventilating airflow around the generator. Inadequate ventilation could result in fire hazard, possible equipment damage, death or serious injury. (000217)



⚠ WARNING

Fire and explosion. Installation must comply with all local, state, and national electrical building codes. Noncompliance could result in unsafe operation, equipment damage, death, or serious injury. (000218)



⚠️ WARNING

Fire hazard. Use only fully-charged fire extinguishers rated “ABC” by the NFPA. Discharged or improperly rated fire extinguishers will not extinguish electrical fires in automatic standby generators.

(000219)



⚠️ WARNING

Risk of Fire. Unit must be positioned in a manner that prevents combustible material accumulation underneath. Failure to do so could result in death or serious injury.

(000147)

Comply with regulations the local agency for workplace health and safety has established. Also, verify that the generator is installed in accordance with the manufacturer’s instructions and recommendations. Following proper installation, do nothing that might alter a safe installation and render the unit in noncompliance with the aforementioned codes, standards, laws, and regulations.

Electrical Hazards



⚠️ DANGER

Electrocution. Contact with bare wires, terminals, and connections while generator is running will result in death or serious injury.

(000144)



⚠️ DANGER

Electrocution. Water contact with a power source, if not avoided, will result in death or serious injury.

(000104)



⚠️ DANGER

Electrocution. Do not wear jewelry while working on this equipment. Doing so will result in death or serious injury.

(000188)



⚠️ DANGER

Electrocution. Never connect this unit to the electrical system of any building unless a licensed electrician has installed an approved transfer switch. Failure to do so will result in death or serious injury.

(000150)



⚠️ DANGER

Electrocution. In the event of electrical accident, immediately shut power OFF. Use non-conductive implements to free victim from live conductor. Apply first aid and get medical help. Failure to do so will result in death or serious injury.

(000145)



⚠️ WARNING

Electrocution. Refer to local codes and standards for safety equipment required when working with a live electrical system. Failure to use required safety equipment could result in death or serious injury.

(000257)

Explosion Hazards



⚠️ DANGER

Explosion and fire. Fuel and vapors are extremely flammable and explosive. No leakage of fuel is permitted. Keep fire and spark away. Failure to do so will result in death or serious injury.

(000192)

⚠️ DANGER

Explosion and fire. Connection of fuel source must be completed by a qualified professional technician or contractor. Incorrect installation of this unit will result in death, serious injury, and property and equipment damage.

(000151a)



⚠️ DANGER

Risk of fire. Allow fuel spills to completely dry before starting engine. Failure to do so will result in death or serious injury.

(000174)



⚠️ WARNING

Risk of Fire. Hot surfaces could ignite combustibles, resulting in fire. Fire could result in death or serious injury.

(000110)

Battery Hazards



⚠ DANGER

Electrocution. Do not wear jewelry while working on this equipment. Doing so will result in death or serious injury.

(000188)



⚠ WARNING

Explosion. Do not dispose of batteries in a fire. Batteries are explosive. Electrolyte solution can cause burns and blindness. If electrolyte contacts skin or eyes, flush with water and seek immediate medical attention.

(000162)



⚠ WARNING

Explosion. Batteries emit explosive gases while charging. Keep fire and spark away. Wear protective gear when working with batteries. Failure to do so could result in death or serious injury.

(000137a)



⚠ WARNING

Electrical shock. Disconnect battery ground terminal before working on battery or battery wires. Failure to do so could result in death or serious injury.

(000164)



⚠ WARNING

Risk of burns. Batteries contain sulfuric acid and can cause severe chemical burns. Wear protective gear when working with batteries. Failure to do so could result in death or serious injury.

(000138a)



⚠ WARNING

Risk of burn. Do not open or mutilate batteries. Batteries contain electrolyte solution which can cause burns and blindness. If electrolyte contacts skin or eyes, flush with water and seek immediate medical attention.

(000163a)

⚠ WARNING

Environmental Hazard. Always recycle batteries at an official recycling center in accordance with all local laws and regulations. Failure to do so could result in environmental damage, death, or serious injury.

(000228)

Always recycle batteries in accordance with local laws and regulations. Contact your local solid waste collection site or recycling facility to obtain information on local recycling processes. For more information on battery recycling, visit the Battery Council International website at: <http://batteryCouncil.org>

Section 2: General Information

Emissions

The United States Environmental Protection Agency (US EPA) (and California Air Resources Board (CARB), for engines/equipment certified to California standards) requires this engine/equipment to comply with exhaust and evaporative emissions standards. Locate the emissions compliance decal on the engine to determine applicable standards. See the included emissions warranty for emissions warranty information. Follow the maintenance specifications in this manual to ensure the engine complies with applicable emissions standards for the duration of the product's life.

Emissions Data Plate

A data plate is attached to the right side engine foot to verify compliance with EPA emissions regulations.

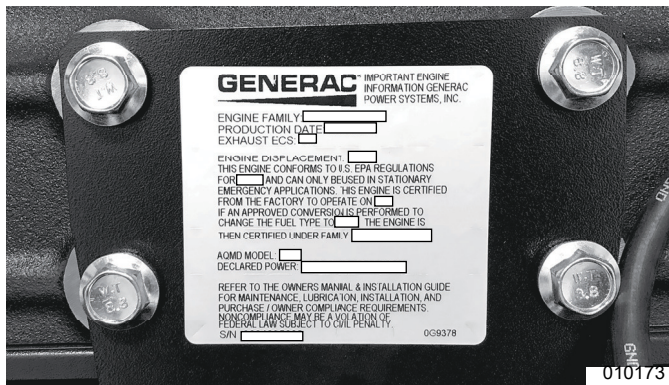

Figure 2-1. Emissions Data Plate (Sample)

Specifications

Model	48 kW	60 kW	80 kW
Engine	4.5L	4.5L	4.5L
Generator Set			
Rotor insulation	Class F	Class H	Class H
Stator insulation	Class H	Class H	Class H
Dimensions L x W x H—in (cm)	83.4 x 35.0 x 45.1 (211.8 x 88.9 x 114.6)	98 x 38 x 49 (248.9 x 96.5 x 124.5)	98 x 38 x 49 (248.9 x 96.5 x 124.5)
Product weight—lbs (kg)	1,781 (808)	1,890 (857)	2,050 (930)
Shipping weight—lbs (kg)	1,893 (859)	2,064 (936)	2,180 (989)

Model	48 kW	60 kW	80 kW
Engine	4.5L	4.5L	4.5L
Engine System			
Type	In-line	In-line	In-line
Dry weight—lbs (kg)	710 (322)	710 (322)	710 (322)
Bore (in/mm)	4.5 / 114.3	4.5 / 114.3	4.5 / 114.3
Stroke (in/mm)	4.25 / 107.95	4.25 / 107.95	4.25 / 107.95
Displacement (L)	4.43L	4.43L	4.43L
Firing order	1-3-4-2	1-3-4-2	1-3-4-2
Direction or rotation	CW from flywheel	CW from flywheel	CW from flywheel
Compression ratio	9.9:1	8.85:1	8.85:1
Spark plug gap (mm)	0.31–0.45	0.31–0.45	0.31–0.45
Rated synchronous rpm	1,800	1,800	1,800
Cooling System			
Water pump	Belt driven	Belt driven	Belt driven
Fan speed (rpm)	2,100	2100	2100
Fan diameter (in/cm)	20 / 508	22 / 56	22 / 56
Fan Mode	Pusher	Pusher	Pusher
Air Flow (ft ³ /min)	2,829	3,197	3,197
Coolant capacity (gal/L)	2.9 / 11	4.5 / 17	4.5 / 17
Heat rejection to coolant (Btu/h)	201,060	204,570	204,570
Max operating air temp on radiator	150 °F (60 °C)	150 °F (60 °C)	150 °F (60 °C)
Max ambient temp	140 °F (50 °C)	140 °F (50 °C)	140 °F (50 °C)
Thermostat (full open)	194 °F (90 °C)	160 °F (71 °C)	160 °F (71 °C)
Lubricating System			
Oil pump type	Gear	Gear	Gear
Oil filter type	Full flow spin-on cartridge	Full flow spin-on cartridge	Full flow spin-on cartridge
Crankcase oil capacity (qts/L)	12 / 11.36	12 / 11.36	12 / 11.36
Lubricating oil type	Citgo Citgard® 5W-20	Citgo Citgard® 5W-20	Citgo Citgard® 5W-20

Model	48 kW	60 kW	80 kW
Engine	4.5L	4.5L	4.5L
Air Intake System			
Type	Naturally aspirated	Turbocharged / Aftercooled	Turbocharged / Aftercooled
Exhaust System			
Breather	Closed	Closed	Closed
Exhaust flow at rated output 60 Hz	104 scfm (2.9 cmm)	181scfm (5.1 cmm)	181 scfm (5.1 cmm)
Exhaust temperature at rated output	945 °F (507 °C)	1,213 °F (656 °C)	1,213 °F (656 °C)
Electrical System			
Battery charge alternator	12V, 35 amp	12V, 35 amp	12V, 35 amp
Recommended battery	Group 27F, 725 CCA	Group 27F, 725 CCA	Group 27F, 725 CCA
Static battery charger	2.5 Amp	2.5 Amp	2.5 Amp
Governor System			
Type	Electronic	Electronic	Electronic
Frequency regulation	Isochronous	Isochronous	Isochronous
Steady state regulation	± 0.25%	± 0.25%	± 0.25%
Voltage Regulator			
Type	Electronic	Electronic	Electronic
Sensing phase	Single-phase	Single-phase	Single-phase
Regulation	± 1%	± 1%	± 1%
Fuel System			
LP fuel pressure	5–14 in water column (1.24–3.48 kPa)	5–14 in water column (1.24–3.48 kPa)	5–14 in water column (1.24–3.48 kPa)
NG fuel pressure	3.5–14 in water column (0.87–3.48 kPa)	3.5–14 in water column (0.87–3.48 kPa)	3.5–14 in water column (0.87–3.48 kPa)

NOTE: A complete specification sheet is included in the documentation provided with the unit at the time of purchase. Contact an IASD for additional copies.

Engine Oil Recommendations

To maintain the product warranty, engine oil should be serviced in accordance with the recommendations of this manual. For your convenience, maintenance kits designed and intended for use on this product are avail-

able from the manufacturer that include engine oil, oil filter, air filter, spark plug(s), a shop towel, and funnel. These kits can be obtained from an IASD.

Although the unit is filled at the factory with 5W-20 engine oil, replace with 5W-30 semi-synthetic blend engine oil at the first oil change, which is due at 25 hours break-in. Select a high-quality detergent oil classified “SJ or SH.” Detergent oils keep the engine cleaner and reduce carbon deposits. After break-in, a synthetic oil that meets or exceeds SAE specifications is recommended. Once synthetic oil is used, it should be used for the life of the generator. It is not recommended to go back to a mineral oil. Do not use special additives.

NOTE: If not already equipped, it is strongly recommended to use the optional Cold Weather Start Kit for temperatures below 32 °F (0 °C). The oil grade for temperatures below 32 °F (0 °C) is 5W-30 synthetic oil.

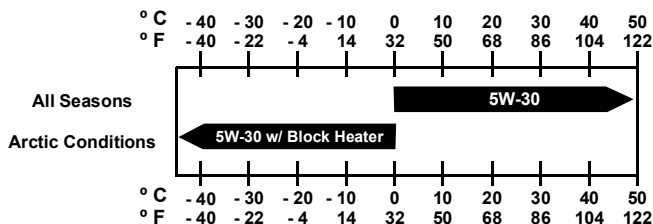

Figure 2-2. Lubricating Oil Recommendations

Weather and Maintenance Kits

The following kits are offered to keep the unit running at its peak:

- Cold Weather Kit
 - Recommended for climates with temperatures below 32 °F (0 °C).
- Extreme Cold Weather Kit
 - Recommended block heater kit for protection in temperatures below 32 °F (0 °C).
- Scheduled Maintenance Kit
 - Kit includes the recommended parts to maintain the generator. See [Service Maintenance Schedule](#) for regular maintenance intervals.

For additional information, or to order any of these kits, contact an IASD or customer service representative.

Coolant Water Treatment



Risk of Poisoning. Do not allow coolant to contact skin or eyes. If coolant is consumed, seek medical attention immediately. Failure to do so will result in death or serious injury.

(000559)

WARNING

Risk of burns. Do not open coolant system until engine has completely cooled. Doing so could result in serious injury.

(000154)

CAUTION

Engine damage. Use approved coolant only. Failure to do so could result in equipment damage.

(000323)

Use of incorrect coolants can damage the engine cooling system. Use demineralized water or distilled water for best results. Hard water causes scale deposits, which reduces cooling efficiency and raises internal temperatures, possibly leading to engine damage. Use an anti-corrosive to prevent rot in summer and anti-freeze to prevent freezing in winter.

Dilute the anti-freeze based on a theoretical temperature that is 9–18 °F (5–10 °C) below the lowest temperature expected in the area. A ratio of 40–60% is most common range.

Freezing Point °F (°C)	-13 (-25)	-31 (-35)	-58 (-50)
Coolant (% Volume)	40	50	60
Water (% Volume)	60	50	40

NOTE: Use only Peak Fleet-Charge® 50/50 ethylene glycol type coolant (available from any IASD).

IMPORTANT NOTE: Do not use propylene glycol type coolant. Using the wrong coolant, mixing different types of coolant, or even mixing different brands of the correct type of coolant, can produce unsatisfactory results, possibly leading to engine damage.

Fuel Requirements

This unit may be equipped with one of the following fuel systems:

- Natural Gas (NG) Fuel System
- Liquid Propane Vapor (LP) fuel system

Recommended fuels must have a BTU content of at least 1,000 BTUs per cubic foot (37.26 megajoules per cubic meter) for NG, or at least 2,520 BTUs per cubic foot (93.8 megajoules per cubic meter) for LP. If converting to LP from NG, a minimum LP tank size of 250 gal (946 L) is recommended. See the installation manual for complete details and procedures.

Reconfiguring the Fuel System

Some models are created fuel specific for either NG or LP and are not fuel convertible, and others are factory-configured for NG, but are field convertible to LP.

To reconfigure the fuel system, navigate to the appropriate menu on the control pad to assign the new fuel type. Before proceeding, be aware the fuel conversion software is password protected.

NOTE: Generac recommends fuel conversion be done by an IASD or a qualified, competent installation contractor or electrician who is familiar with applicable codes, standards, and regulations.

Change Fuel Selection

NOTE: Failure to convert the software will result in decreased performance and an increase in emissions, which is a violation of Environmental Protection Agency (EPA) regulations. It is the responsibility of the installer to verify only the correct recommended fuel is supplied to the generator fuel system. Thereafter, the owner/operator must verify only the correct fuel is supplied.

1. Selecting the correct fuel type occurs during the Install Wizard Process. Navigate the software using UP arrow, DOWN arrow, ENTER, and ESCAPE. See [Figure 4-2](#) for more information.

Battery Requirements

Group 27R, 12 volt	4.5L Engine: For areas where temperatures regularly drop below 24 °F (-4 °C).
NOTE: Battery dimensions (L x W x H) for Group 26 battery must not exceed 8-3/16 in x 6-13/16 in x 7-3/4 in (20.8 cm x 17.3 cm x 19.7 cm).	
Group 31R, 12 volt	Upgrade option for 4.5L Engine: For areas where temperatures regularly drop below 24 °F (-4 °C).
NOTE: Battery dimensions (L x W x H) for Group 31R battery must not exceed 13 in x 6-13/16 in x 9-7/16 in (33 cm x 17.3 cm x 24 cm).	

Battery Charger

A 2.5 amp battery charger is integrated into the control panel module. It operates as a “smart charger” which verifies output charging levels are safe and continuously optimized to promote maximum battery life.

Battery Safety Precautions



⚠ DANGER

Electrocution. Do not wear jewelry while working on this equipment. Doing so will result in death or serious injury.

(000188)



⚠ WARNING

Risk of burns. Batteries contain sulfuric acid and can cause severe chemical burns. Wear protective gear when working with batteries. Failure to do so could result in death or serious injury.

(000138a)



⚠ WARNING

Explosion hazard. Never add acid to a battery. Add distilled water only. Failure to do so could result in death, serious injury, or equipment damage.

(000316)



⚠ WARNING

Risk of burn. Do not open or mutilate batteries. Batteries contain electrolyte solution which can cause burns and blindness. If electrolyte contacts skin or eyes, flush with water and seek immediate medical attention.

(000163a)



⚠ WARNING

Electrocution. Never charge a battery in wet conditions. Doing so could result in death, serious injury, equipment or property damage.

(000482)



⚠ WARNING

Electrical shock. Disconnect battery ground terminal before working on battery or battery wires. Failure to do so could result in death or serious injury.

(000164)



⚠ WARNING

Explosion. Batteries emit explosive gases while charging. Keep fire and spark away. Wear protective gear when working with batteries. Failure to do so could result in death or serious injury.

(000137a)



⚠ WARNING

Explosion. Do not dispose of batteries in a fire. Batteries are explosive. Electrolyte solution can cause burns and blindness. If electrolyte contacts skin or eyes, flush with water and seek immediate medical attention.

(000162)

Always recycle batteries in accordance with local laws and regulations. Contact your local solid waste collection site or recycling facility to obtain information on local recycling processes. For more information on battery recycling, visit the Battery Council International website at: <http://batteryCouncil.org>

- Stationary emergency generators installed with automatic transfer switches will crank and start automatically when NORMAL (UTILITY) source voltage is removed or is below an acceptable pre-set level. Do not connect battery cables until NORMAL (UTILITY) source voltage at transfer switch is correct and system is ready to be placed into operation to prevent automatic startup and possible injury to personnel.
- Only use tools with insulated handles when working on the battery. Do not lay tools or metal parts on top of the battery.
- Discharge static electricity from the body before touching the battery by first touching a grounded metal surface.
- Immediately wash down spilled electrolyte with an acid neutralizing agent. Use a solution of 1 lb (500 g) bicarbonate of soda to 1 gal (4 L) of water. Add the bicarbonate of soda solution until evidence of reaction (foaming) has ceased. Flush the resulting liquid with water.

Corrosion Protection

Periodically wash and wax the enclosure using automotive type products. Frequent washing is recommended in salt water/coastal areas.

Section 3: Activation and Startup

Orientation

NOTE: The 4.5L (48 kW) unit is depicted in the artwork used in this manual. The location and appearance of some components may vary between engine models.

See **Figure 3-1**. The viewing window (A) side of the enclosure is identified as the rear of the generator set. The right and left sides are identified by standing at the rear and looking towards the front of the unit. The battery is located on the left side of the unit (B).

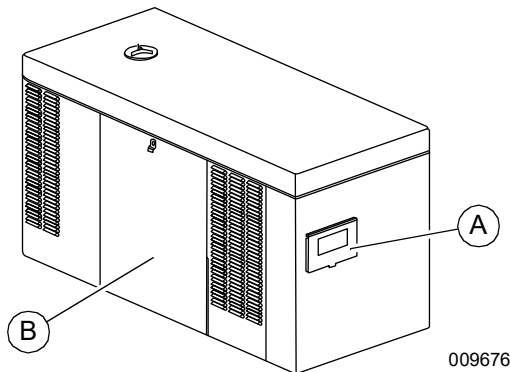

Figure 3-1. Enclosure (Rear Left View)

Removing the Side Access Panels

NOTE: Access panels are located at both the left and right sides of the enclosure.

Proceed as follows to remove the side access panels:

1. See **Figure 3-2**. Remove key (B) from bag attached to door of unit.

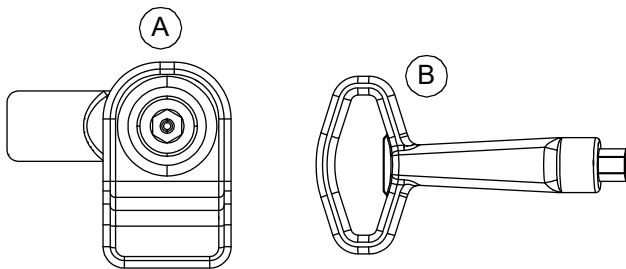

010077

Figure 3-2. Access Panel Key and Latch (Typical)

2. Insert key into latch (A) and rotate counterclockwise one half turn.
3. Raise panel using thumb latch.

Installing the Battery



WARNING

Explosion. Batteries emit explosive gases. Always connect positive battery cable first to avoid spark. Failure to do so could result in death or serious injury.

(000133)

Proceed as follows to install the battery:

1. Loosen nylon strap on battery tray.
2. See **Figure 3-3**. Install battery (C) onto tray.

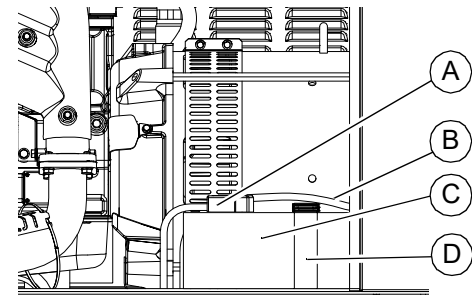
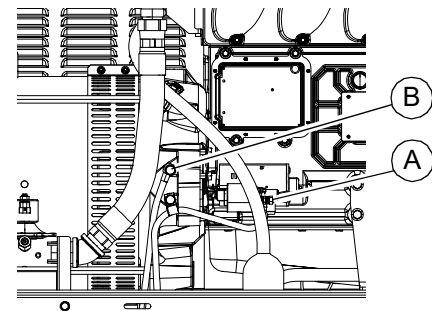

010078

Figure 3-3. Battery Cable Connections

3. Secure nylon strap (D) over top of battery and tighten.
4. Install positive battery cable (red) (A) to positive (+) battery terminal.
5. Install negative battery cable (black) (B) to negative (-) battery terminal.

Opening the Viewing Window

Proceed as follows to open the viewing window:

1. Remove plastic film from both sides of viewing window.
2. Lift viewing window up to access control panel.
3. See [Figure 3-4](#). To hold viewing window open, remove rod from clip at back of window and insert into hole in frame (A).

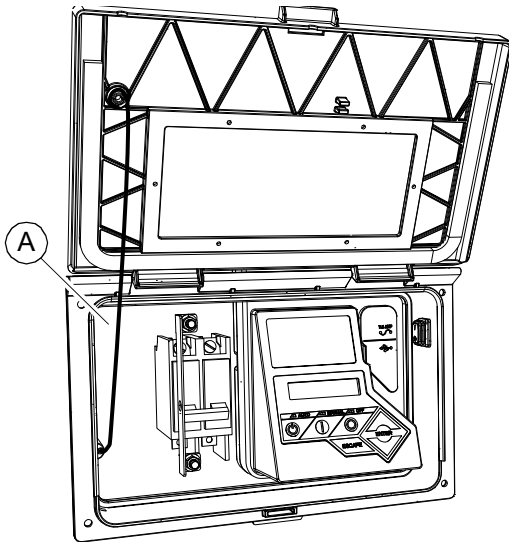

006373

Figure 3-4. Viewing Window

Activating the Unit

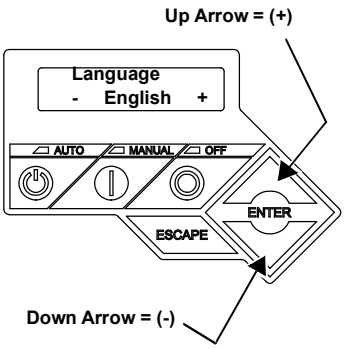
<p>Display Reads:</p>  <p>Up Arrow = (+)</p> <p>Down Arrow = (-)</p>	<p>Generator Active is displayed on the LCD during initial startup. After displaying firmware and hardware version codes, as well as other system information, the Install Wizard is launched, and the Language screen is displayed.</p> <p>Use Up arrow or Down arrow to scroll to desired language.</p> <p>Press ENTER.</p>	<p>If the wrong language is selected, it may be changed later using the Edit menu.</p>
<p>Display Reads:</p> <div style="border: 1px solid black; padding: 5px; text-align: center;"> <p>Activate me (ENT) or ESC to run in manual</p> </div>	<p>Press ENTER.</p>	<p>Press ESCAPE to abort the activation sequence. NOT ACTIVATED is displayed and unit will run in MANUAL only. Disconnect and reconnect the negative battery cable to restart the activation routine. If power is removed after a successful activation, no data is lost, but time and date must be updated.</p>
<p>Display Reads:</p> <div style="border: 1px solid black; padding: 5px; text-align: center;"> <p>To Activate go to www.activategen.com</p> </div>	<p>Go to www.activategen.com or call 1-888-9ACTIVATE (922-8482, US & Canada only) if activation passcode is not available.</p> <p>If activation pass code is available, wait a few seconds for the next display.</p>	
<p>Display Reads:</p> <div style="border: 1px solid black; padding: 5px; text-align: center;"> <p>SN 1234567890 PASS CODE XXXXX</p> </div>	<p>Use Up arrow or Down arrow to increment or decrement the digit to correspond to the first number of the pass code.</p> <p>Press ENTER.</p> <p>Repeat step to enter remaining digits.</p>	<p>Press ESCAPE to return to preceding digits if a correction becomes necessary.</p> <p>If attempts to enter activation code are unsuccessful, verify number against the activation code given on activategen.com. If it is correct, contact 1-888-9ACTIVATE (922-8482, US & Canada only). For international assistance, call 01-262-953-5155.</p>
<p>Display Reads:</p> <div style="border: 1px solid black; padding: 5px; text-align: center;"> <p>Select Hour (0-23) - 6 +</p> </div>	<p>Use Up arrow or Down arrow to increment or decrement the hour. Press ENTER.</p> <p>Use Up arrow or Down arrow to increment or decrement the minute. Press ENTER.</p> <p>Use Up arrow or Down arrow to select the month. Press ENTER.</p> <p>Use Up arrow or Down arrow to increment or decrement the date. Press ENTER.</p> <p>Use Up arrow or Down arrow to increment or decrement the year. Press ENTER.</p>	

<p>Display Reads:</p> <div style="border: 1px solid black; padding: 10px; text-align: center;"> <p>Quiet Test Mode? Yes No</p> </div>	<p>Use Up arrow or Down arrow to select either Yes or No.</p> <p>Press ENTER.</p>	<p>Select YES to perform exercise at low speed. Select NO to perform exercise at normal operating speed.</p>
<p>Display Reads:</p> <div style="border: 1px solid black; padding: 10px; text-align: center;"> <p>Select Hour (0-23) - 1 +</p> </div>	<p>Set Exercise Time.</p> <p>Use Up arrow or Down arrow to increment or decrement the hour. Press ENTER.</p> <p>Use Up arrow or Down arrow to increment or decrement the minute. Press ENTER.</p> <p>Use Up arrow or DOWN arrow to scroll to the day of the week. Press ENTER.</p>	<p>In AUTO, the engine starts and runs once each week at the time and day specified. During the exercise cycle, the unit runs approximately 12 minutes and then shuts down. Transfer of loads to the generator does not occur unless utility power fails.</p>
<p>Display Reads:</p> <div style="border: 1px solid black; padding: 10px; text-align: center;"> <p>Fuel Selection</p> <p>- LP +</p> <p>- NG +</p> </div>	<p>Fuel Type Selection.</p> <p>Use UP or DOWN arrow to index the correct fuel type.</p> <p>Press ENTER.</p> <p>Select the correct fuel based on the fuel connected at the installation site.</p>	

Starting and Running Engine

Proceed as follows to start and run the engine:

1. See [Figure 3-5](#). Pull up rubber flap covering fuse holder and verify installation of 7.5 amp fuse (A).

Press OFF on the control panel to stop the engine. A red LED illuminates to verify system is OFF.

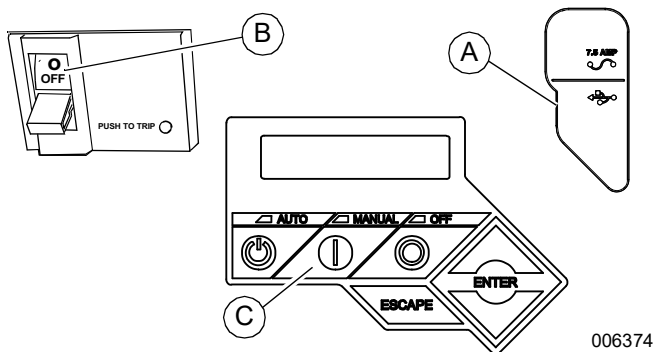

Figure 3-5. Generator Control Panel

2. Set the main line circuit breaker (MLCB) (generator disconnect) to OFF (OPEN) (B).
3. Verify both auxiliary shutdown switches are ON (I). See [Figure 3-6](#) for locations.
4. Press MANUAL on control panel (C) to start engine. A blue LED illuminates to verify system is in MANUAL.
5. Allow engine to run until it reaches normal operating temperature.

Operational Checks

NOTE: The following procedures require special tools and skills. Contact an IASD to perform these tasks.

Self Test

Upon startup, controller goes through a system self test which checks for utility voltage on the DC circuits. This is done to prevent damage if installer mistakenly connects AC utility power sense wires into DC terminal block. If utility voltage is detected, controller displays a warning message and locks out the generator, preventing damage to the controller. Remove power to controller to clear this warning.

Utility voltage must be turned on and present at N1 and N2 terminals inside generator control panel for this test to be performed and pass.

Complete the following before starting:

1. Verify generator is OFF. A red LED on control panel illuminates to verify system is off.
2. Verify generator MLCB (generator disconnect) is OFF (OPEN).
3. Turn off all circuit breakers/electrical loads to be powered by the generator.
4. Verify both auxiliary shutdown switches are ON (I).
5. Check coolant and engine lubricating oil levels. See [Inspecting Coolant Level and Hoses](#) and [Checking Lubricating Oil Level and Drain Hose](#).

During initial startup only, generator may exceed normal number of start attempts and experience an “over crank” fault. This is due to accumulated air in the fuel system during installation. Reset control board and restart up to two more times, if necessary. If unit fails to start, contact an IASD for assistance.

Checking Manual Transfer Switch Operation



⚠ DANGER

Electrocution. High voltage is present at transfer switch and terminals. Contact with live terminals will result in death or serious injury.

(000129)

See Manual Transfer Operation section of owner's manual for procedures.

Electrical Checks



⚠ DANGER

Electrocution. High voltage is present at transfer switch and terminals. Contact with live terminals will result in death or serious injury.

(000129)

Proceed as follows to complete electrical checks:

1. Verify generator is in OFF mode. A red LED on control panel illuminates to verify system is OFF.
2. Verify generator MLCB (generator disconnect) is OFF (OPEN).
3. Turn off all circuit breakers/electrical loads to be supplied by generator.
4. Turn on utility power supply to transfer switch using the means provided (such as a utility MLCB).
5. Use an accurate AC voltmeter to verify utility power source voltage across transfer switch terminals N1, N2, and N3 (if three-phase). Normal line-to-line voltage should be equivalent to rated unit voltage.
6. Verify utility power source voltage across terminals N1, N2, and N3 (if three-phase) and the transfer switch neutral lug.
7. Turn off utility power supply to transfer switch when utility supply voltage is compatible with transfer switch and load circuit ratings.
8. Press MANUAL on control panel to crank and start engine.
9. Allow engine to warm up for approximately five minutes. Set generator MLCB (generator disconnect) to ON (CLOSED).
10. Connect an accurate AC frequency meter across transfer switch terminal lugs E1, E2, and E3 (if three-phase) and verify correct rated frequency (50 Hz or 60 Hz).
11. Use an accurate AC voltmeter to verify generator output voltage across transfer switch terminals E1 to E2, (E2 to E3 and E3 to E1 if three-phase). Normal line-to-line voltage should be equivalent to site specific utility voltage.
12. Successively connect the AC voltmeter test leads across terminal lugs E1 and Neutral, then E2 and Neutral (and E3 and Neutral if three-phase). Line-to-neutral reading in each case should match utility voltage reading. Verify generator phase rotation matches utility phase rotation if system is three-phase.
13. Set generator MLCB (generator disconnect) to OFF (OPEN).
14. Press OFF on control panel to shut engine down.

IMPORTANT NOTE: Do not proceed unless generator AC voltage and frequency are correct and within stated limits.

Testing Generator Under Load



⚠ DANGER

Electrocution. Do not manually transfer under load. Disconnect transfer switch from all power sources prior to manual transfer. Failure to do so will result in death or serious injury, and equipment damage.

(000132)

Proceed as follows to test generator set with electrical loads applied:

1. Verify generator is in OFF mode. A red LED on control panel illuminates to verify system is off.
2. Turn off all breakers/electrical loads to be supplied by generator.
3. Turn off utility power supply to transfer switch, using the means provided (such as a utility MLCB).
4. Manually set transfer switch to STANDBY, i.e., load terminals connected to generator's E1, E2, and E3 (if three-phase) terminals.
5. Press MANUAL on control panel. Engine will crank and start.
6. Allow engine to warm up for a few minutes.
7. Set generator MLCB (generator disconnect) to ON (CLOSED). The transfer switch is now powered by standby generator.
8. Turn on circuit breaker/electrical loads supplied by generator.
9. Connect a calibrated AC voltmeter and a frequency meter across terminal lugs E1, E2, and E3 (if three-phase). Voltage should be approximately unit rated voltage. Verify with clamp on amp meter to verify unit is not overloaded.
10. Allow generator run at full rated load for 20–30 minutes. Listen for unusual noises, vibration, or other indications of abnormal operation. Inspect for oil leaks, evidence of overheating, etc.
11. Turn off electrical loads when testing under load is complete.
12. Set generator MLCB (generator disconnect) to OFF (OPEN).
13. Allow engine to run at no-load for 2–5 minutes.
14. Press OFF on control panel to shut engine down. A red LED illuminates to verify system is OFF.

Testing Auxiliary Shutdown Switch Operation

The generator is equipped with an independent means of shutting down prime mover (engine) for use in emergency situations. The shutdown mechanism, when activated, requires a mechanical reset.

See **Figure 3-6**. Generators 15 kW and larger are equipped with two auxiliary shutdown switches. One auxiliary shutdown switch (A) is located on the generator roof above and to the right of the viewing window. The second auxiliary shutdown switch (B) is inside the control panel enclosure.

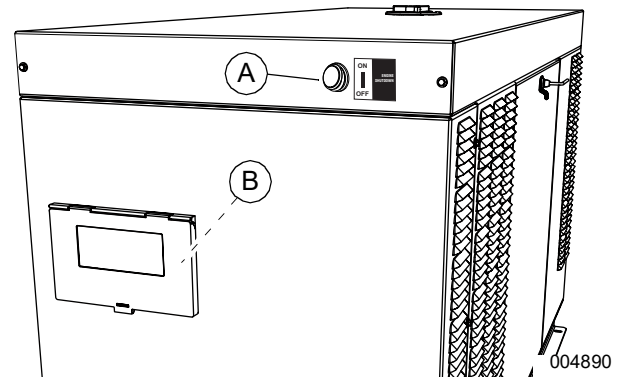

Figure 3-6. Auxiliary Shutdown Switches

Proceed as follows to test auxiliary shutdown switches after installation to verify correct operation:

1. Verify auxiliary shutdown switches are ON (I).
2. Press MANUAL on control panel to start engine.
3. With engine running, set one auxiliary shutdown switch to OFF (O). Engine should shut down immediately.
 - **If engine stops**, set auxiliary shutdown switch to ON (I), clear alarm on controller, and restart engine to verify generator is operating normally. After verifying normal operation of first auxiliary switch, verify operation of second auxiliary switch.
 - **If engine does not stop**, auxiliary shutdown switch is not functioning correctly. Contact an IASD.

NOTE: Auxiliary shutdown switches are not intended to be a primary means to shut down generator under normal operating conditions. Accidental activation of an auxiliary shutdown switch will prevent generator from operating during a power outage.

Checking Automatic Operation

Proceed as follows to check system for correct automatic operation:

1. Verify generator is in OFF mode. A red LED on control panel illuminates to verify system is OFF.
2. Install front cover of transfer switch.
3. Turn on utility power supply to transfer switch, using the means provided (such as a utility MLCB).

NOTE: Transfer switch will transfer to UTILITY.

4. Set generator MLCB (generator disconnect) to ON (CLOSED).
5. Press AUTO on control panel. The system is now ready for automatic operation.
6. Turn off utility power supply to transfer switch.

With generator ready for automatic operation, engine will crank and start when utility source power is turned off after a 10 second delay (factory default setting). After starting, transfer switch connects load circuits to standby side. Allow system to operate through its entire automatic sequence of operation.

With generator running and loads powered by generator AC output, turn on utility power supply to transfer switch. The system transfers back to utility position and then runs through cool down cycle and shuts down.

Securing the Generator

Proceed as follows to secure the generator:

1. Use key to install side access panels.
2. Close viewing window.

NOTE: See [Figure 3-7](#). Obtain viewing window hasp, if not installed. With retaining tab at the bottom, insert square end of viewing window hasp into slot below viewing window. Push on viewing window hasp until it snaps in place. Gently pull on viewing window hasp to verify it will not come free.

3. Install customer supplied padlock into viewing window hasp.



Figure 3-7. Install Viewing Window Hasp

This page intentionally left blank.

Section 4: Operation

Control Panel

⚠ DANGER

Automatic start-up. Disconnect utility power and render unit inoperable before working on unit. Failure to do so will result in death or serious injury.

(000191)

NOTE: The control panel is intended for use by qualified service personnel only.

See [Figure 4-1](#). The control panel is located behind the viewing window at the rear of the unit. See [Figure 3-5](#) and [Figure 3-6](#).

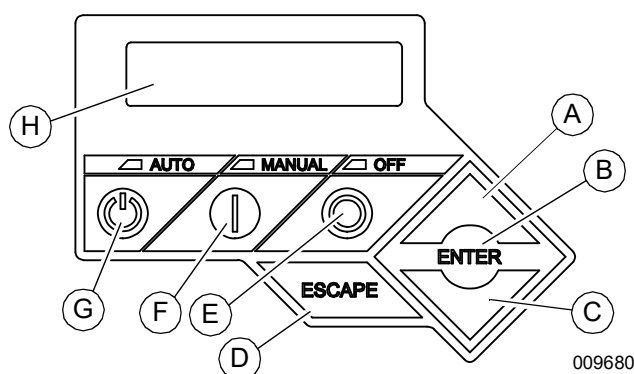

A	Up arrow	E	OFF
B	ENTER	F	MANUAL
C	Down arrow	G	AUTO
D	ESCAPE	H	LCD

Figure 4-1. Control Panel and LCD

IMPORTANT NOTE: With control panel set to **AUTO**, engine may crank and start at any time without warning. Such automatic starting occurs during the programmed exercise cycle or when utility power source voltage drops below configured level. To prevent possible injury that might occur during sudden starts, always set control panel to **OFF** and remove the 7.5 amp fuse before working on or around the generator or transfer switch. For added security, place a **DO NOT OPERATE** tag or placard on both the control panel and transfer switch.

AUTO/MANUAL/OFF

Feature	Description
AUTO	Activates fully automatic operation. Green LED illuminates to verify system is in AUTO. Transfer to standby power occurs if utility power fails. Functionality of exercise timer is enabled, if set.
MANUAL	Cranks and starts engine. Blue LED illuminates to verify system is in MANUAL. Transfer to standby power occurs if utility power fails. Functionality of exercise timer is disabled.
OFF	Shuts down engine, if running. Red LED illuminates to verify system is in OFF. Transfer to standby power does not occur if utility power fails.

Menu Navigation

See [Figure 4-2](#).

Feature	Description
System Menus	
HOME Screen	System returns to Home screen if control panel is not used for five minutes. Screen normally displays a status message, such as Ready to Run (AUTO) or Switched to OFF (OFF), and total Hours of Protection. If an active alarm/warning condition occurs, the associated Alarm/Warning message is displayed. To clear Alarm/Warning message, press OFF on control panel, followed by ENTER. In the event of multiple Alarms/Warnings, next message is then displayed. The highest priority alarm is always displayed first.
Display Backlight	Normally off. If operator presses any button, backlight will automatically light and remain on for 30 seconds.
MAIN MENU	Allows operator to navigate software using up arrow, down arrow, ENTER, and ESCAPE. MAIN MENU can be accessed from any sub menu by consecutively pressing ESCAPE. Each time ESCAPE is pressed, the preceding menu is displayed. MAIN MENU is reached when System, Date/Time, Battery, and Sub-Menus are displayed.
SUB-MENUS	Sub-Menu screen includes HISTORY, MAINT, EDIT, and DEALER menus.
HISTORY	HISTORY screen includes an alarm log and run log. Alarm log displays the last 50 alarm events. Run log displays the last 50 operational events.
MAINTENANCE MENU	Includes Run Hours, Maintenance Log, and Schedule. Run Hours displays cumulative hours on engine. Maintenance Log displays the last service warnings and service completions. Schedule displays when the next scheduled maintenance interval warning will occur.
EDIT MENU	Includes Language, Current Date/Time, Exercise Settings, Firmware Update, Startup Delay, and Warm up Time. All of these settings are adjustable without a password.
DEALER MENU	Includes password protected settings and can be adjusted by an IASD during installation or a service visit.
Navigation	
ESCAPE	Used to abort a routine or return to the preceding menu.
ENTER	Used to make a selection or save an entry.
UP ARROW DOWN ARROW	Used to move forward or backward from menu to menu, or to scroll forward or backward (increment or decrement) through available selections.
NOTE: Pressing the control panel illuminates the backlight for 30 seconds. The backlight also illuminates for 30 seconds whenever an active Alarm/Warning message is displayed.	

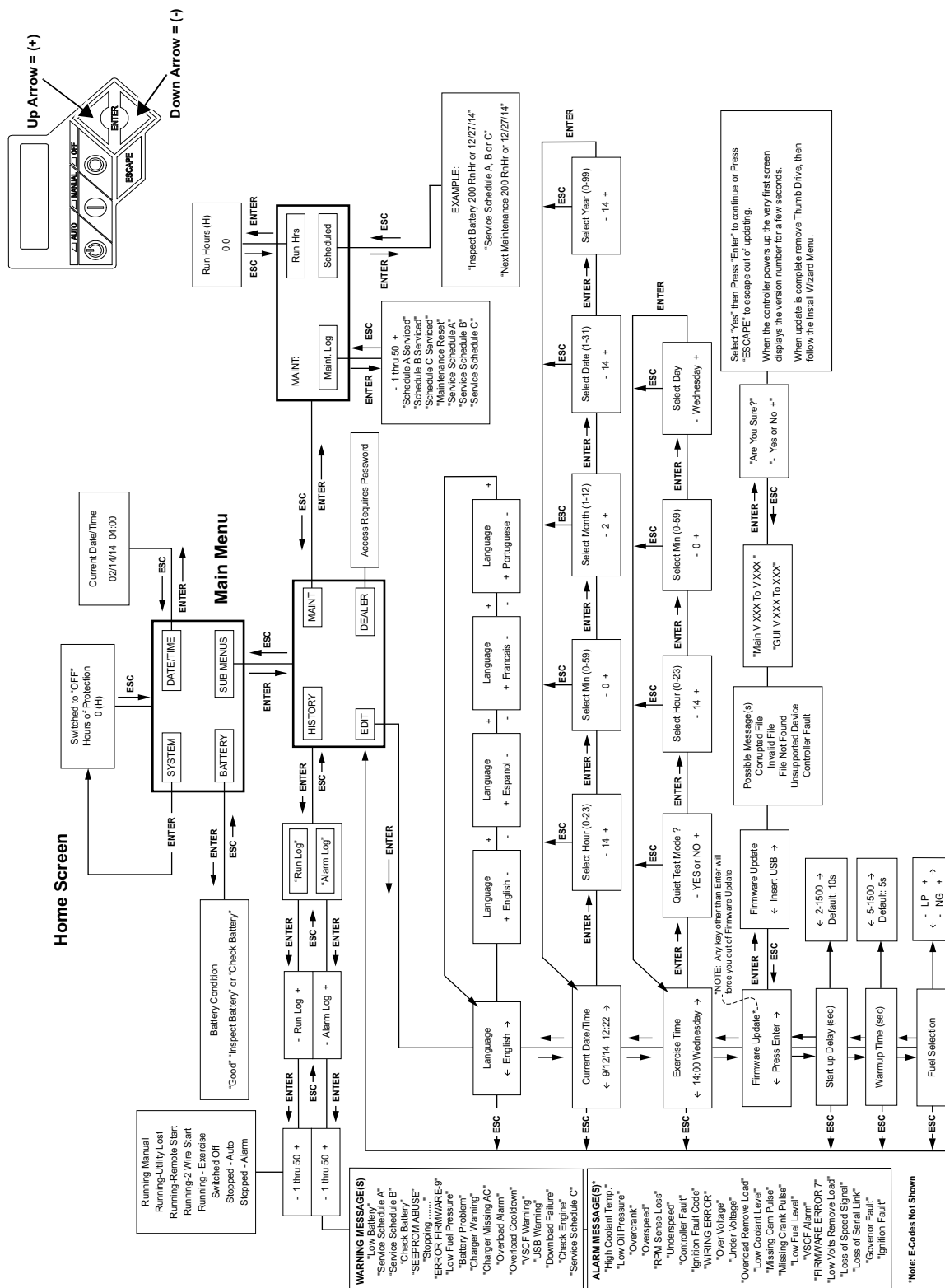

Figure 4-2. Navigation Menu

011127

Alarm/Warning Conditions

The owner/operator is alerted to Alarm and/or Warning conditions via the control panel LCD. All Alarm conditions cause the generator to shut down.

The Warning messages alert the operator to conditions that do not disable the unit or require immediate correction.

The possible Alarm/Warning messages are listed below.

Alarm Messages

- High Engine Temperature
- Low Oil Pressure
- Overcrank
- Overspeed
- RPM Sense Loss
- Underspeed
- Controller Fault
- Ignition Fault Code
- Auxiliary Shutdown
- WIRING ERROR
- Over Voltage
- Under Voltage
- Overload
- Canbus Error
- Missing Cam Pulse
- Missing Crank Pulse
- Low Fuel Pressure
- E-Stop

Warning Messages

- Low Battery
- Exercise Set Error
- Schedule A Maintenance
- Schedule B Maintenance
- Schedule C Maintenance
- Battery Problem
- Charger Warning
- Charger Missing AC
- USB Warning
- Download Failure
- Check Engine

NOTE: Unless correctly trained to correct and clear Alarm/Warning conditions, contact an IASD or trained service technician.

Changing Date/Time

To change date/time after activation, see Navigation Menu in [Figure 4-2](#). If power is lost (battery is disconnected/reconnected, control panel fuse is removed/installed, etc.), display automatically prompts user for Date/Time. All other information is retained in memory.

Programmable Timers**Dealer Programmable****Exercise Time**

A programmable exercise time is provided. In AUTO, engine starts and runs once each week at time and day specified. During exercise cycle, unit runs approximately 12 minutes and then shuts down. Transfer of loads to generator does not occur unless utility power fails.

NOTE: A dealer password is required to change duration of exercise cycle.

User Programmable**Startup Delay Timer**

A programmable line interrupt delay (or startup delay) timer is provided. When utility voltage fails (falls below 60% of nominal), the startup delay timer is started. If voltage rises above utility volts low threshold, timer is reset. If utility voltage remains below utility volts low threshold during the duration of the timer, unit cranks and starts.

NOTE: Factory default setting is five seconds, but is adjustable from 2 to 1,500 seconds.

Warm-Up Delay Timer

A programmable warm-up delay timer is provided. As soon as generator starts, the warm-up timer starts. When the warm-up timer expires, controller transfers load to generator (through transfer switch) if utility voltage is less than 80% of nominal. If utility voltage is greater than threshold at expiration of warm-up timer, load is **not** transferred to generator and a cool-down period begins. At the end of the cool-down period, generator stops.

NOTE: Factory default setting is five seconds, but is adjustable from 5 to 1,500 seconds.

USB Port for Firmware Updates

A USB port is located beneath the rubber flap on the control panel, and is provided for firmware updates. Firmware updates must be performed by an IASD.

IMPORTANT NOTE: USB port is intended for use with a USB thumb drive only. USB port is not intended for charging devices such as phones or laptops. Do not connect any consumer electronics to USB port. Contact an IASD for any firmware updates.

Battery Charger

NOTE: Battery charger is integrated into control panel module.

The battery charger verifies:

- Output is continually optimized to promote maximum battery life.
- Charging levels are safe.

NOTE: A warning message is displayed on the LCD when the battery requires service.

Transfer Switch Automatic Operation

In AUTO, generator starts automatically when utility source voltage drops below preset level. Loads are transferred to standby power source once unit starts.

Proceed as follows to select automatic operation:

1. Verify transfer switch main contacts are set to UTILITY (loads connected to utility power source).
2. Verify normal utility power source voltage is available to transfer switch terminal lugs N1, N2, and N3 (if three-phase).
3. Set generator MLCB (generator disconnect) to ON (CLOSED).
4. Press AUTO on control panel. A green LED illuminates to verify system is in AUTO.

Automatic Sequence of Operation

Utility Failure

If control panel is set to AUTO when utility power fails, a **10** second startup delay timer is started (user programmable). If utility power is still absent when time expires, engine cranks and starts.

Once started, a **five** second engine warm-up delay timer starts (user programmable). When time has elapsed, load is transferred to generator. If utility power is restored (above 90% of nominal, dealer programmable) between the time engine is first started and expiration of warm-up time, controller completes the start cycle and then runs through its normal cool-down cycle (while load remains on utility source throughout the episode).

Cranking

The cyclic cranking is controlled as follows:

15 seconds crank, seven seconds rest, seven seconds crank, seven seconds rest; this sequence is repeated for a total of six crank cycles.

Load Transfer

With generator running, transfer of load is dependent upon the operating mode as follows:

AUTO	<ul style="list-style-type: none"> • Starts and runs if utility power fails (falls below 60% of nominal) for five consecutive seconds (adjustable). • Starts a five second (adjustable) engine warm-up timer. • Does not execute transfer if utility power returns before expiration of warm-up timer (but finishes warm-up and cool-down cycles). • Transfers back to utility once utility power returns (above 80% of nominal) for 15 consecutive seconds. • Only shuts down if OFF is pressed or an alarm shutdown occurs. • Once utility power returns, starts a cool-down cycle before it shuts down. <p>NOTE: Cool-down cycle is five minutes if turbocharger equipped, one minute if naturally aspirated.</p>
	<p>EXERCISE</p> <ul style="list-style-type: none"> • Only works in AUTO. • Does not exercise if generator is already running in AUTO. • During exercise cycle, transfers only if utility power fails for 10 consecutive seconds.
MANUAL	<ul style="list-style-type: none"> • Engine cranks and runs even if utility power is present, but does not transfer to generator. • Transfers to generator if utility fails (falls below 60% of nominal) for 10 consecutive seconds. • Transfers back to utility when utility returns for 15 consecutive seconds. Engine continues to run until AUTO or OFF is pressed.

Transfer Switch Manual Operation



⚠ DANGER

Electrocution. Do not manually transfer under load. Disconnect transfer switch from all power sources prior to manual transfer. Failure to do so will result in death or serious injury, and equipment damage.
(000132)

Prior to automatic operation, manually exercise transfer switch to verify there is no binding or interference with correct operation of the mechanism. Manual operation of transfer switch is required if automatic operation fails.

IMPORTANT NOTE: Always use applicable transfer switch owner's manual for actual manual transfer switch operation instructions. The information presented here describes a typical V-style transfer switch, which is not used for three-phase applications. See specific manual for three-phase transfer switch.

Transfer to Generator Power

Proceed as follows to manually transfer to standby power and start the generator when utility power fails:

1. Press OFF on control panel. A red LED illuminates to verify system is OFF.
2. Set generator MLCB (generator disconnect) to OFF (OPEN).
3. Turn off utility power supply to transfer switch using the means provided (such as a utility MLCB).
4. See [Figure 4-3](#). Use the manual transfer handle (A) inside the transfer switch to set main contacts to STANDBY (loads connected to standby power source) (C).

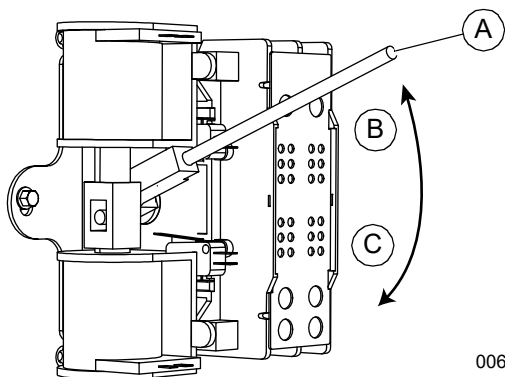

006375

Figure 4-3. Manual Transfer Switch Operation (Typical)

5. Press MANUAL on control panel. Engine cranks and starts.
6. Allow engine to run for two minutes to bring it up to normal operating temperature.
7. Set generator MLCB (generator disconnect) to ON (CLOSED).

Transfer Back to Utility Power

Proceed as follows to manually transfer back to utility power and shut down generator when utility power is restored:

NOTE: Verify utility voltage has returned and is at the correct value.

1. Set generator MLCB (generator disconnect) to OFF (OPEN).
2. Allow engine to run for two minutes at no-load to bring it up to normal operating temperature.
3. Press OFF on control panel to shut down engine.
4. Verify utility power supply to transfer switch is turned off.
5. See [Figure 4-3](#). Use the manual transfer handle inside the transfer switch to set main contacts to UTILITY (loads connected to utility power source) (B).
6. Turn on utility power supply to transfer switch using the means provided (such as a utility MLCB).
7. Press AUTO on control panel. A green LED illuminates to verify system is in AUTO.

Section 5: Maintenance

Component Locations

NOTE: The 4.5L (48 kW) unit is depicted in the artwork used in this manual. The location and appearance of some components may vary between engine models.

The viewing window side of the enclosure is identified as the rear of the generator set. The right and left sides are identified by standing at the rear and looking towards the front of the unit.

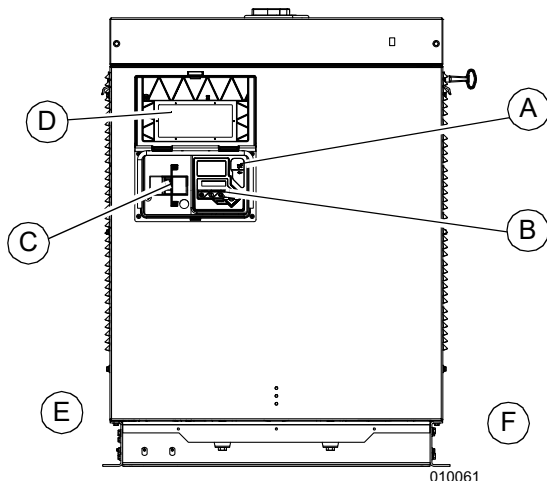

A	7.5 Amp fuse and USB port
B	Control panel and LCD
C	Main line circuit breaker (MLCB)
D	Viewing window
E	Left side
F	Right side

Figure 5-1. Rear View

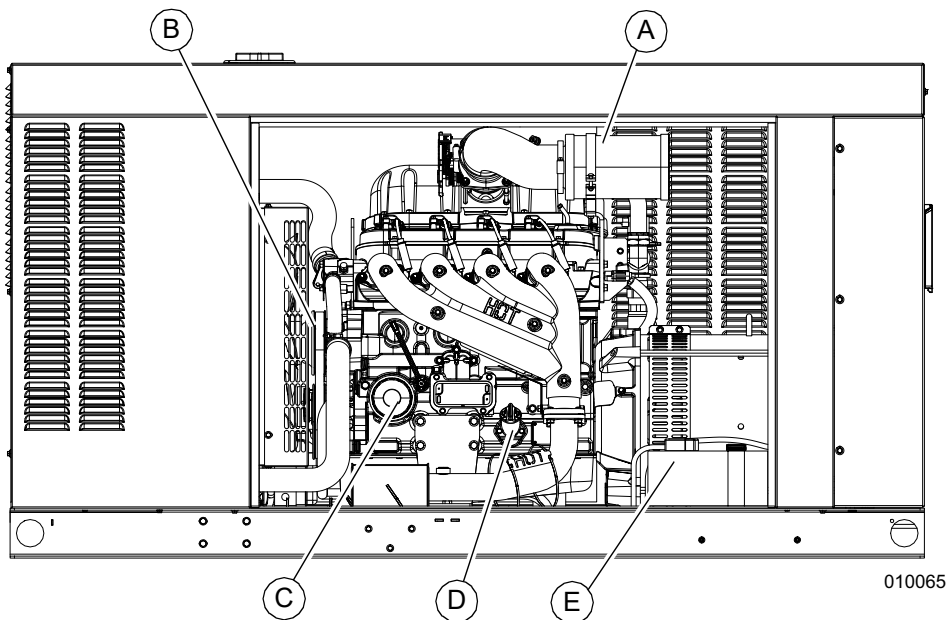

A	Air filter element
B	Accessory/fan belt
C	Oil filter
D	Oil level dipstick/fill cap
E	Battery

Figure 5-2. Left Side View

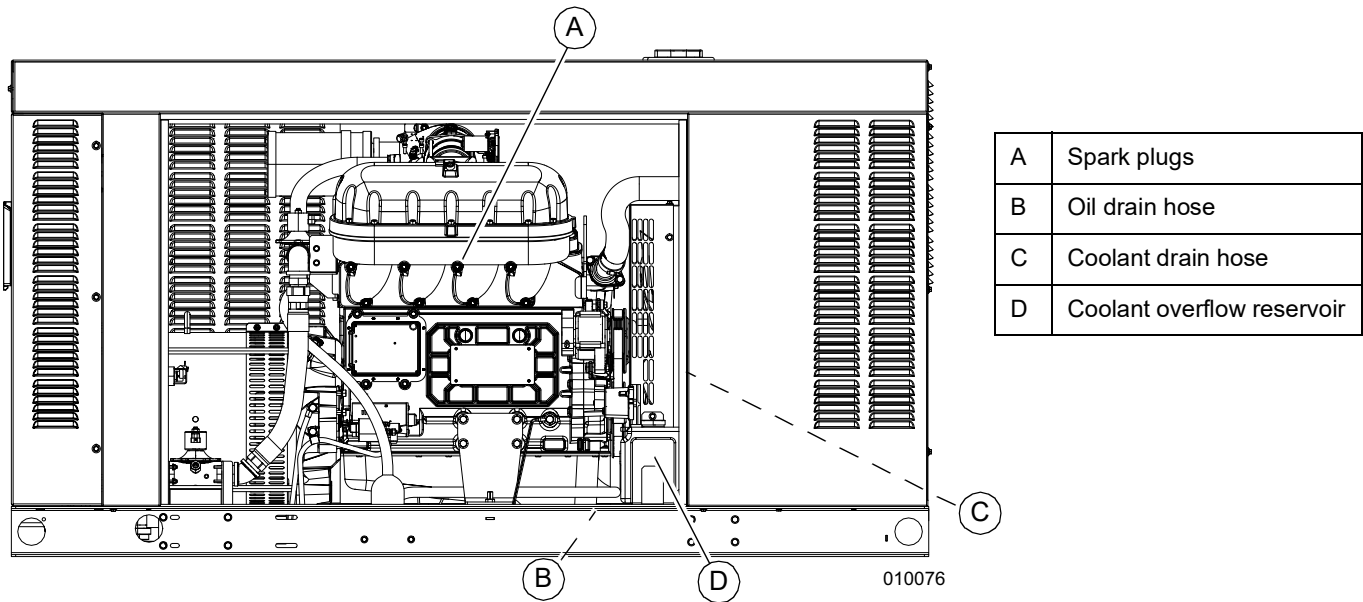

Figure 5-3. Right Side View

NOTE: All normal maintenance and service items are easily accessible for consumer convenience. Wherever possible, touch points are colored orange to provide for quick and easy recognition.

Access Panels

Access panels are located at both the left and right sides of the enclosure.

Removal

Proceed as follows to remove the access panels:

1. See [Figure 5-4](#). Insert key (B) into thumb (A) latch and rotate counterclockwise one-half turn.

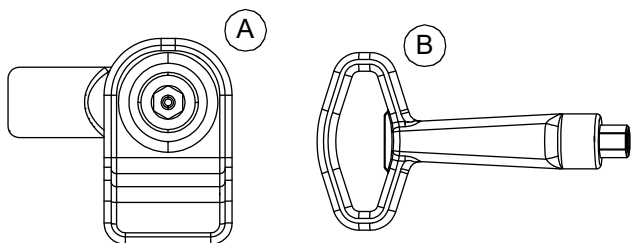

010077

Figure 5-4. Access Panel Key and Latch (Typical)

2. Raise panel using thumb latch.

Installation

Proceed as follows to install the access panels:

1. Lower panel into position using thumb latch.
2. Insert key into latch and rotate clockwise one-half turn.

Maintenance

Regular maintenance will improve performance and extend engine/equipment life. Generac Power Systems, Inc. recommends that all maintenance work be performed by an Independent Authorized Service Dealer (IASD). Regular maintenance, replacement, or repair of the emissions control devices and systems may be performed by any repair shop or person of the owner's choosing. To obtain emissions control warranty service free of charge, the work must be performed by an IASD. See the emissions warranty.

WARNING

Equipment damage. Only qualified service personnel may install, operate, and maintain this equipment. Failure to follow proper installation requirements could result in death, serious injury, and equipment or property damage. (000182a)

It is important to perform all maintenance at the interval specified in [Service Maintenance Schedule](#). This verifies safe and correct operation, as well as compliance with applicable emissions standards.

Service Maintenance Schedule

Observe the maintenance tasks and intervals shown in the table below.

Service	25 Hours Engine Break-In	Daily If Running Continuously	Schedule A Every Year or 125 Hours	Schedule B Every 2 Years or 250 Hours	Schedule C Every 1000 Hours
Inspect enclosure louvers		•	•	•	•
Inspect fuel hoses		•	•	•	•
Inspect coolant level and hoses		•	•	•	•
Inspect radiator for clogging		•	•	•	•
Inspect lubricating oil level and drain hose		•	•	•	•
Replace lubricating oil and oil filter*	•		•	•	•
Inspect battery condition/fluid level			•	•	•
Inspect/adjust accessory/drive belt tension			•	•	•
Replace air filter element			•	•	•
Drain/flush coolant system				•	•
Clean/gap/replace spark plugs				•	•
Tighten critical fasteners					•
* 1 year or 200 hours per oil change, whichever comes first.					

NOTE: If the unit reaches a Schedule A or Schedule B maintenance interval with 900 to 999 total hours, have an IASD perform the Schedule C maintenance tasks as well (and reset the A-B-C/Year maintenance schedule counter).

Remove From Service

WARNING

Accidental Start-up. Disconnect the negative battery cable, then the positive battery cable when working on unit. Failure to do so could result in death or serious injury. (000130)

For safety, follow the steps below prior to inspection, maintenance, or service.

IMPORTANT NOTE: If currently experiencing a utility outage, see [Removal From Service During Utility Outage](#) for special instructions.

1. Open viewing window. See [Opening the Viewing Window](#).
2. See [Figure 5-5](#). Set generator MLCB (generator disconnect) to OFF (OPEN) (A).

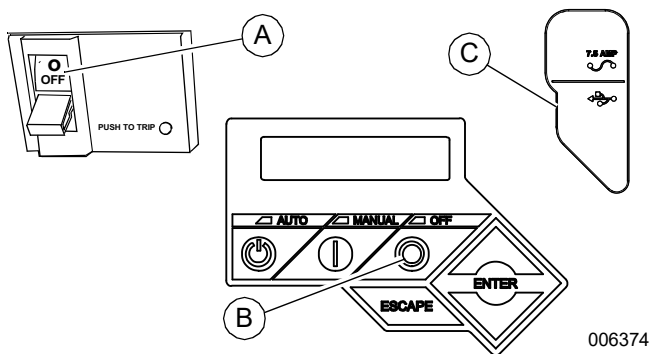

Figure 5-5. Generator Control Panel

3. Verify both auxiliary shutdown switches are OFF (OPEN).
4. Press OFF on control panel (B). A red LED illuminates to verify system is OFF.
5. Remove T1 fuse from transfer switch.
6. Pull up rubber flap (C) covering fuse holder and remove 7.5 amp fuse.
7. Disconnect negative battery cable.
8. Place a DO NOT OPERATE tag or placard on both the control panel and transfer switch.
9. If unit has been running, wait five minutes for engine to cool.

25 Hour Break-In

Perform the following task:

- Replace lubricating oil and oil filter.

NOTE: See [Replacing Lubricating Oil and Oil Filter](#) under Schedule A Maintenance.

Daily Maintenance

Perform the following tasks:

- Inspect enclosure louvers.
- Inspect fuel lines.
- Inspect coolant level and hoses.
- Inspect radiator for clogging.
- Inspect lubricating oil level and drain hose.

NOTE: See [Inspecting the Enclosure Louvers](#) through [Inspecting Coolant Level and Hoses](#) under Schedule A Maintenance.

Schedule A Maintenance

NOTE: Perform Schedule A maintenance once each year or after 125 hours of service, whichever comes first.

NOTE: The 4.5L (48 kW) unit is depicted in the artwork used in this manual.

Schedule A Maintenance Item Locations

NOTE: The viewing window side of the enclosure with is identified as the rear of the generator set. The right and left sides are identified by standing at the rear and looking towards the front of the unit.

Model	48kW / 60kW / 80 kW
Engine	4.5L
Coolant overflow reservoir	R
Oil dipstick	L
Oil drain hose	R
Oil filter	L
Oil supply tank fill cap	L
Battery	L
Fan belt	E
Air filter element	L
R = Right Side L = Left Side E = Either Side	

Preliminary Instructions

1. See [Remove From Service](#).
2. Remove left and right side access panels. See [Access Panels](#).
3. Remove negative battery cable (black) from negative (-) battery terminal.

Inspecting the Enclosure Louvers

1. Verify intake and exhaust louvers and openings are clean and unobstructed. Keep clear of leaves, grass, snow, and debris.
2. Wipe exterior surfaces clean using a damp cloth.
3. Loosen dirt, oil, etc. with a soft bristle brush.
4. Remove loose dirt and debris using a vacuum cleaner, or low pressure compressed air (not exceeding 25 psi [172 kPa]).

NOTE: Periodically wash and wax enclosure using automotive type products. Frequent washing is recommended in salt water or coastal areas.

Inspecting the Fuel Lines

1. Inspect fuel lines for leaks. Tighten fittings and clamps if necessary.
2. Inspect fuel lines for nicks, dents, kinks, or other damage. Replace as necessary.

Inspecting Coolant Level and Hoses



WARNING

Risk of burns. Allow engine to cool before draining oil or coolant. Failure to do so could result in death or serious injury.

(000139)

Proceed as follows to inspect the coolant level and hoses:

1. See [Figure 5-6](#). Verify coolant level is between HOT and COLD marks on the overflow reservoir.

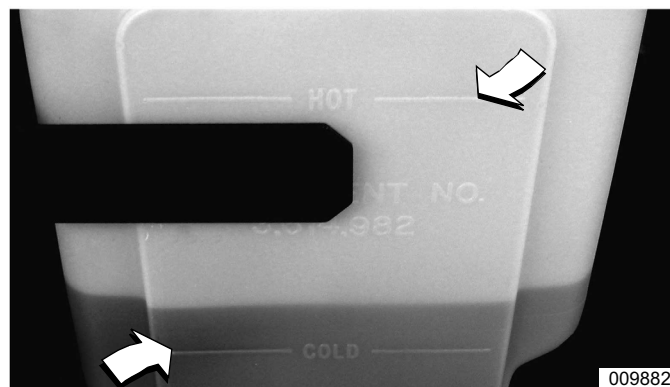

Figure 5-6. Coolant Overflow Reservoir

NOTE: Coolant expands when hot, so coolant level may be higher than the HOT mark. Do not add coolant higher than the HOT mark.

2. If coolant level is below the COLD mark, remove fill cap from overflow reservoir and add coolant. See [Coolant Water Treatment](#).
3. Inspect coolant hoses for leaks. Tighten hose clamps, if necessary.
4. Inspect hoses for nicks, cuts, tears, or general deterioration. Replace as necessary.

Inspecting Radiator for Clogging

Proceed as follows to check radiator for clogging:

1. Use a flashlight to inspect the radiator fins.
2. Inspect for debris, accumulations of dirt, or other deposits.
3. Carefully remove any debris from radiator fins. Use warm soapy water and a soft bristled brush to remove dirt and other deposits, if necessary.

Checking Lubricating Oil Level and Drain Hose

NOTE: If changing engine lubricating oil and filter, see [Replacing Lubricating Oil and Oil Filter](#).

Proceed as follows to check oil level and oil drain hose:

1. If engine was running, wait at least 10 minutes to verify oil has fully drained into oil pan.

NOTE: The most accurate oil level readings are obtained when engine is cold.

2. See [Figure 5-2](#). Remove oil dipstick (D) and wipe dry with a clean, lint free cloth.
3. Slowly insert oil dipstick into oil dipstick tube.
4. Verify oil dipstick is fully seated in oil dipstick tube.

NOTE: Some oil dipsticks require more effort to fully seat than others.

5. Allow at least 10 seconds to elapse.
6. See [Figure 5-7](#). Slowly remove oil dipstick (A).

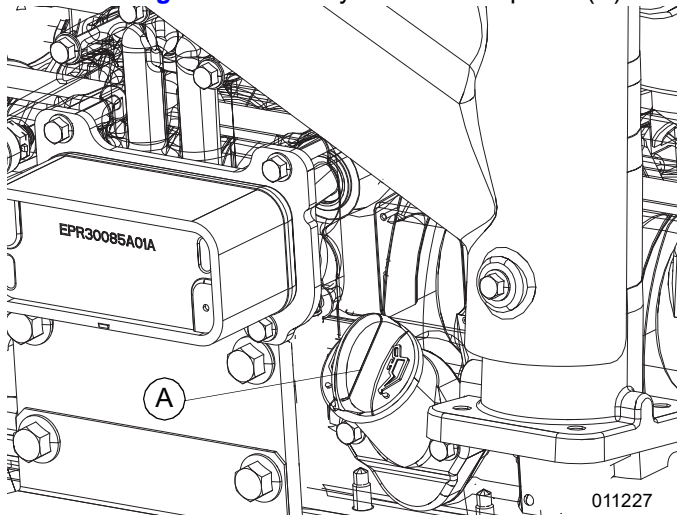

Figure 5-7. Oil Dipstick Location

7. See [Figure 5-8](#). Verify oil level is at or near FULL mark (A). Add oil as necessary.

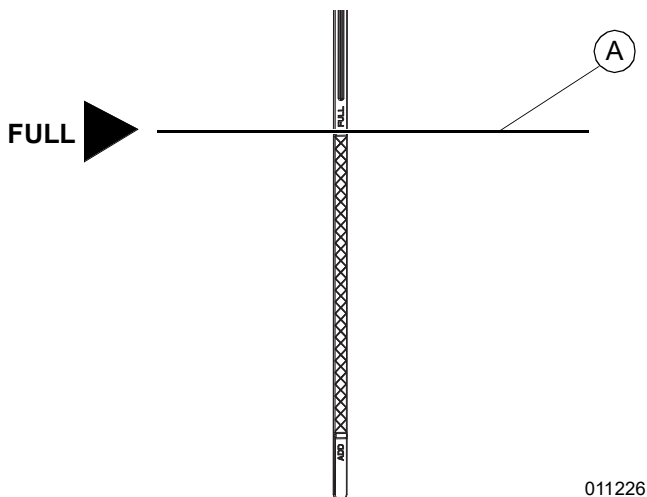

Figure 5-8. Oil Level Dipstick Full Mark

NOTE: Observe oil level on both sides of oil dipstick. The lower of the two readings is the correct oil level measurement.

8. If necessary, remove oil fill cap and slowly add oil. **Do not fill above “FULL” mark on oil dipstick.**
9. Install oil dipstick and oil fill cap.
10. Install negative battery cable (black) onto negative battery (-) terminal.
11. Pull up rubber flap covering fuse holder and install 7.5 amp fuse.
12. Press MANUAL on control panel to start engine.
13. Allow engine to run for one minute.
14. Press OFF on control panel to shut down engine. A red LED illuminates to verify system is OFF.
15. Return to step 1.

NOTE: The most common reasons for inaccurate oil level readings are:

- Reading oil dipstick before oil has fully drained into oil pan.
 - Inserting and removing oil dipstick too quickly.
 - Reading oil dipstick when it has not been fully seated in oil dipstick tube.
 - Reading only the high level side of oil dipstick.
16. Inspect oil drain hose for leaks. Inspect oil drain hose for nicks, cuts, tears, or general deterioration. Replace as necessary.
 17. Pull up rubber flap covering fuse holder and remove 7.5 amp fuse.
 18. Remove negative battery cable (black) from negative battery (-) terminal.

Replacing Lubricating Oil and Oil Filter



WARNING

Risk of burns. Allow engine to cool before draining oil or coolant. Failure to do so could result in death or serious injury.

(000139)

WARNING

Skin irritation. Avoid prolonged or repeated contact with used motor oil. Used motor oil has been shown to cause skin cancer in laboratory animals. Thoroughly wash exposed areas with soap and water.

(000210)

NOTE: Complete this procedure once yearly, or every 200 hours of operation, whichever comes first.

Proceed as follows to replace lubricating oil and oil filter:

1. See [Figure 5-9](#). Remove oil drain hose from holding clamp (B).



Figure 5-9. Oil Drain Hose Holding Clamp

2. Use one wrench to hold hex on oil drain hose fitting (to prevent rotation), and use second wrench to remove oil drain plug.
3. Drain oil into a suitable container.
4. Install oil drain plug onto end of oil drain hose.
5. Install oil drain hose into holding clamp.
6. See [Figure 5-2](#). Turn oil filter (C) counterclockwise to remove from oil filter adapter.
7. Apply a light coat of clean engine oil to gasket of **new** oil filter.
8. Install oil filter by hand until gasket just contacts oil filter adapter. Tighten oil filter an additional three-quarters to one full turn.
9. Remove oil fill cap and fill engine with the recommended quantity and type of oil. See [Engine Oil Recommendations](#). Crankcase oil capacity is listed below:

Model	Engine	System Capacity
48 kW / 60 kW / 80k W	4.5 L	12 qts (11.4 L)

10. Install oil fill cap.
11. Install negative battery cable (black) onto negative (-) battery terminal.
12. Pull up rubber flap covering fuse holder and install 7.5 amp fuse.
13. Press MANUAL on control panel to start engine.
14. Allow engine to run for one minute. Inspect for leaks while engine is running.
15. Press OFF on control panel. A red LED illuminates to verify system is OFF.
16. Wait 10 minutes for engine to cool and to allow oil to drain back to oil pan.
17. Check oil level and add oil as necessary. See [Checking Lubricating Oil Level and Drain Hose](#).
18. Install oil fill cap.

NOTE: Dispose of used oil and oil filter in accordance with local, state, or national laws.

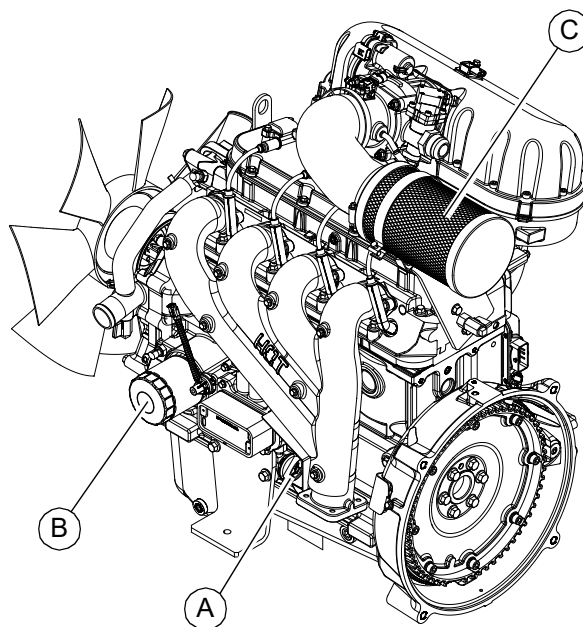

010152

Figure 5-10. Engine Oil and Air Cleaner Maintenance

A	Oil fill cap/oil dipstick
B	Oil filter
C	Air cleaner

Checking Battery Condition/Fluid Level

Checking Condition and Cleaning

1. See [Figure 3-3](#) for illustration. Verify top of battery is clean and dry. Dirt and electrolyte on top of the battery can cause battery to self-discharge. Clean battery top with a solution of baking soda (sodium bicarbonate) and water (5 teaspoons baking soda per quart or liter of water). When solution stops bubbling, rinse off the battery with clean water.
2. Clean cable clamps and battery terminals using a wire brush or sandpaper to remove any oxidation.
3. Inspect battery screws, clamps, and cables for breakage, loose connections, and corrosion. Tighten and clean as necessary.
4. Inspect battery posts for melting or damage caused by over tightening.
5. Inspect battery for discoloration, raised top, or a warped or distorted case, which might indicate battery has been frozen, overheated, or overcharged.
6. Inspect battery case for cracks or leaks.
7. Check battery fluid level of unsealed batteries. See [Checking Fluid Level](#).
8. Verify battery state of charge. See [Verifying Battery State of Charge](#).
9. Replace battery if necessary. See [Battery Replacement](#).

Checking Fluid Level

Check the fluid level of unsealed batteries. If necessary, fill with distilled water only. DO NOT use tap water.

Verifying Battery State of Charge

Verify the battery state of charge using a digital multimeter (DM). Recharge and retest if state of charge is below manufacturer's recommendations. Replace battery if necessary.

Battery Replacement

Removal



⚠ WARNING

Electrical shock. Disconnect battery ground terminal before working on battery or battery wires. Failure to do so could result in death or serious injury. (000164)

⚠ WARNING

Accidental Start-up. Disconnect the negative battery cable, then the positive battery cable when working on unit. Failure to do so could result in death or serious injury. (000130)

Proceed as follows to remove the battery:

1. Remove negative battery cable (black) from negative (-) battery terminal.
2. Remove positive battery cable (red) from positive (+) battery terminal.
3. See [Figure 5-11](#). Install rubber protective cover over positive (+) battery terminal (A).

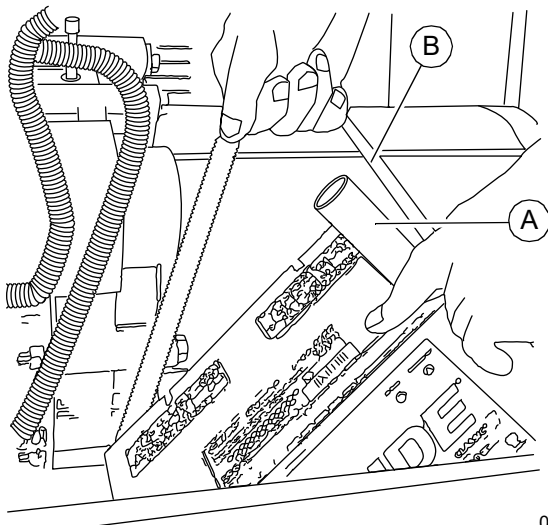

001499

Figure 5-11. Remove/Install Battery

4. Loosen two screws with nylon washers to release battery hold-down clamp from battery tray.

5. Grasp battery strap (B), and lift battery from battery tray.
6. Remove rubber protective cover from positive (+) battery terminal.

Installation

⚠ WARNING

Accidental Start-up. Disconnect the negative battery cable, then the positive battery cable when working on unit. Failure to do so could result in death or serious injury. (000130)

Proceed as follows to install the battery:

1. Install rubber protective cover over positive (+) battery terminal.
2. Grasp battery strap and lift battery.
3. Set battery onto battery tray.
4. Tighten two screws with nylon washers to secure hold-down clamp to battery tray.
5. Remove rubber protective cover from positive (+) battery terminal.
6. Install positive battery cable (red) to positive (+) battery terminal.
7. Install negative battery cable (black) to negative (-) battery terminal.

NOTE: If continuing with Schedule A maintenance procedures, leave negative battery cable (black) disconnected.

Inspecting Accessory/Drive Belt

Inspection

NOTE: 4.5L (48 kW) units are provided with an automatic belt tensioner and do not need adjustment.

Proceed as follows to inspect accessory/drive belt condition:

1. Perform visual inspection as follows:
 - Inspect belt for cracks, fraying, excessive wear, or other damage.
 - Verify belt is free of grease and oil.
 - Replace belt if contaminated, damaged, frayed, or worn.

NOTE: Use a solution of soap and warm water to clean pulleys, if necessary. Avoid use of solvents, but if used, always follow by a soap and water wash.

2. Verify fan belt deflection.

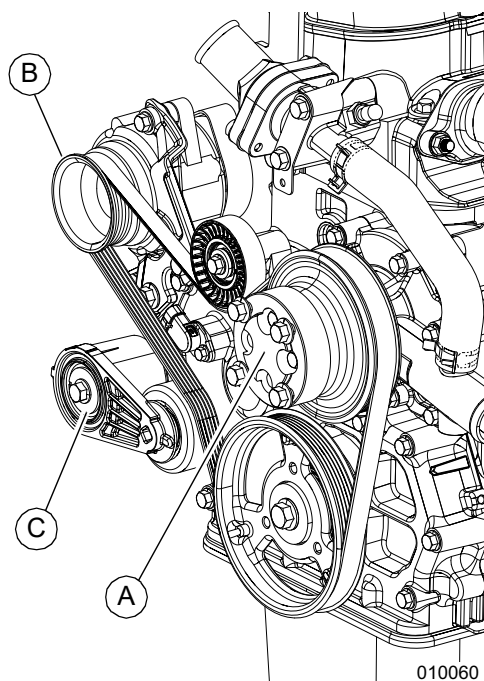

Figure 5-12. Check Accessory/Drive Belt Deflection

A	Water pump pulley
B	Alternator pulley
C	Automatic tensioner

Replacing Air Filter Element

Proceed as follows to replace air filter element:

1. See [Figure 5-13](#). Remove nut (B) and bolt (C) from air filter clamp, and loosen elbow clamp (D) to release air cleaner.

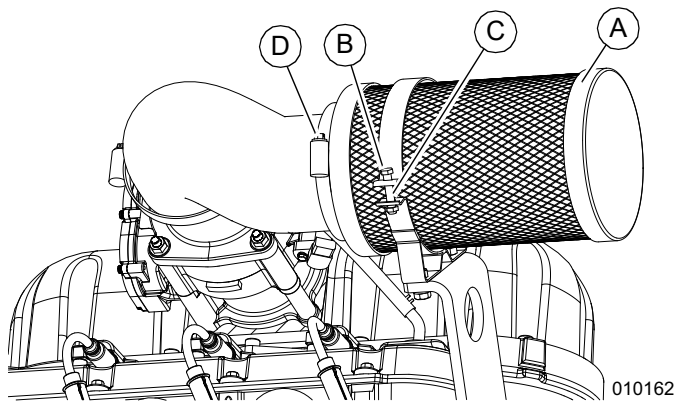

Figure 5-13. Air Cleaner Cover and Filter Element

2. Remove air filter element (A) and discard.
3. Thoroughly clean elbow of any dust, dirt, or debris.
4. Place **new** air filter element into elbow clamp.
5. Install elbow clamp over clamping surfaces and tighten. Install nut and bolt from air filter clamp, and tighten until snug.

NOTE: Service kits are available from an IASD.

Final Instructions

Proceed as follows if only performing Schedule A maintenance procedures:

1. Install negative battery cable (black) onto negative battery (-) terminal.
2. Install left and right side access panels. See [Access Panels](#).
3. See [Return To Service](#).

Schedule B Maintenance

NOTE: Perform Schedule B maintenance every two years or after 250 hours of service, whichever comes first. Before proceeding below, first perform all tasks listed under Schedule A Maintenance.

NOTE: The 2.4L (32 kW) unit is depicted in the artwork used in this manual. For the general location of components in all other models, see [Schedule B Maintenance Item Locations](#).

Schedule B Maintenance Item Locations

NOTE: The viewing window side of the enclosure is identified as the rear of the generator set. The right and left sides are identified by standing at the rear and looking towards the front of the unit.

Model	48 kW / 60 kW / 80 kW
Engine	4.5L
Coolant drain hose	R
Radiator fill cap	T
Coolant overflow reservoir	R
Spark plugs	L
R = Right Side L = Left Side T = Top	

Draining and Flushing Coolant System



WARNING

Risk of burns. Allow engine to cool before draining oil or coolant. Failure to do so could result in death or serious injury.

(000139)

Proceed as follows to drain and flush the coolant system:

1. Disconnect and empty coolant overflow reservoir.
2. Install and connect coolant overflow reservoir.
3. Rotate and remove plastic cover at top of enclosure.
4. Slowly unscrew radiator cap.
5. Locate drain screw at bottom left side of radiator.

NOTE: If unit is not equipped with drain hose, install suitable length of rubber hose to drain screw.

6. See [Figure 5-14](#). Rotate hex fitting to open drain screw (A).

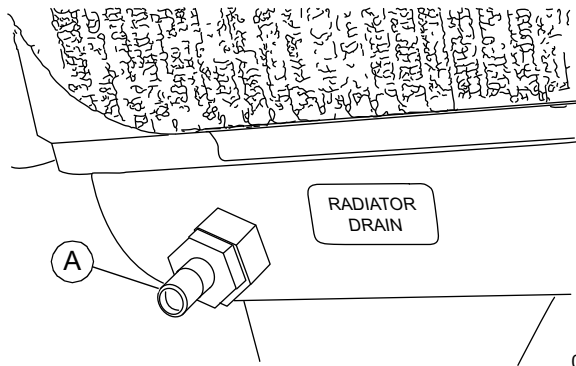

001493

Figure 5-14. Radiator Drain Location

NOTE: Drain hose removed for illustration purposes.

7. Remove coolant drain hose from holding clamp.
8. Use wrench to hold hex on coolant hose fitting (to prevent rotation), and use second wrench to remove drain plug.
9. Drain coolant into a suitable container.
10. Install drain plug at end of coolant drain hose.
11. Install coolant drain hose in holding clamp.
12. Rotate hex fitting to close radiator drain screw.
13. Obtain recommended quantity and type of coolant. See [Coolant Water Treatment](#).

Model (kW)	Engine	System Coolant Capacity
48	4.5 L	10 qt (9.5 L)
60 / 80	4.5 L	18 qt (17 L)

14. See [Figure 5-15](#). Insert funnel into filler neck of radiator (B). See [Draining and Flushing Coolant System](#).

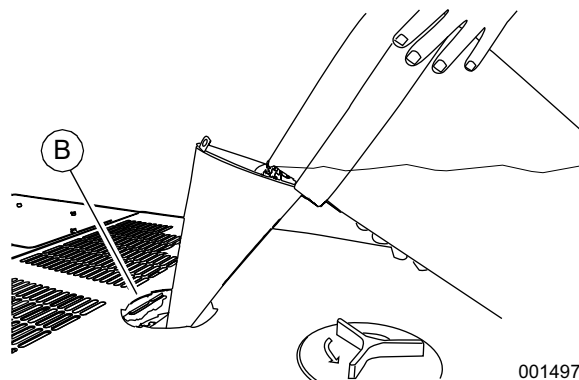

001497

Figure 5-15. Filling Coolant System

15. Slowly pour coolant into filler neck until radiator is full.
16. Install radiator cap.

17. Press MANUAL on control panel to start engine. A blue LED illuminates to verify system is in MANUAL.
18. Allow engine to run until thermostat opens, as indicated by heating of top radiator hose.
19. Inspect coolant hoses for leaks. Tighten clamps, if necessary.
20. Press OFF on control panel to shut engine down.
21. Allow engine to cool.
22. Repeat steps 4–21 to drain and refill cooling system.
23. Slowly unscrew radiator cap. Slowly pour coolant into filler neck until radiator is full.
24. Add coolant to the overflow reservoir. See [Inspecting Coolant Level and Hoses](#).
25. Install plastic cover at top of enclosure and rotate until tight.
26. Inspect hoses for nicks, cuts, tears, or general deterioration. Replace as necessary.

Clean/Gap/Replace Spark Plugs



⚠ WARNING

Electric shock. Do not disconnect spark plug wires with engine running. Doing so could result in death or serious injury.

(000140a)

Proceed as follows to clean, gap, or replace spark plugs as follows:

1. Remove negative battery cable (black) from negative battery (-) terminal.
2. See [Figure 5-16](#). Remove spark plug cables (C) from spark plug terminals (D).

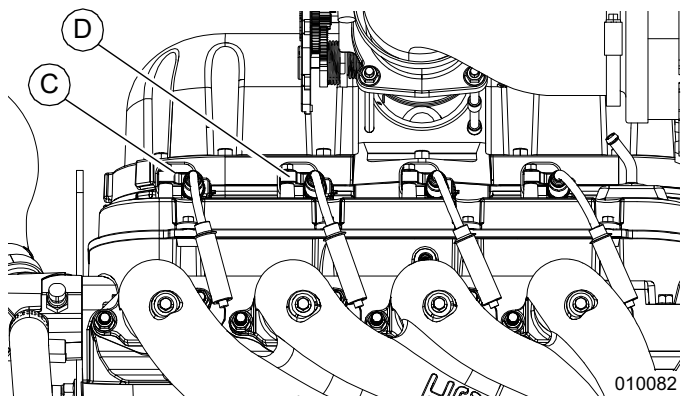

Figure 5-16. Remove Spark Plug Cables

NOTE: When disconnecting spark plug cable from spark plug terminal, always grasp and pull on the boot at the terminal end of the cable. Pulling on cable portion can result in parts damage.

3. Thoroughly clean area around spark plugs.

4. Remove spark plugs from cylinder head using an appropriate spark plug socket wrench.
5. Inspect condition of threads in cylinder head and on spark plugs. If necessary, soften deposits with penetrating oil and clean out with a thread chaser.
6. Clean spark plugs using a wire brush and commercial solvent. Do not blast spark plugs. Use **new** spark plugs if necessary.
7. See [Figure 5-17](#). Inspect spark plug gap using a wire feeler gauge. Adjust gap by carefully bending ground electrode as follows:

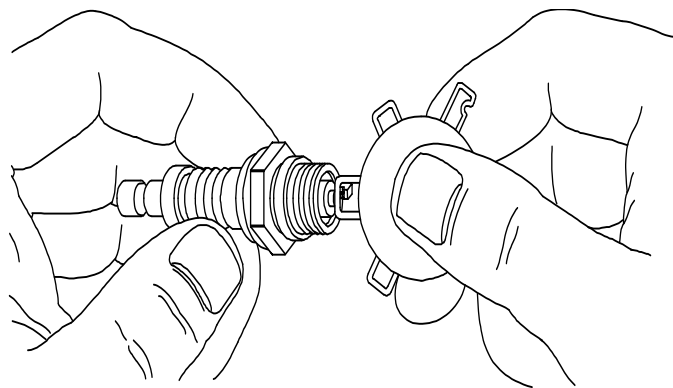

Figure 5-17. Adjusting Spark Plug Gap

Model	Engine	Spark Plug Gap
48 kW / 60 kW / 80 kW	4.5L	0.012–0.017 in (0.31–0.45 mm)

8. Finger tighten spark plugs into cylinder head, and then using a spark plug socket, tighten as follows:

Spark Plug Torque		
Engine	ft-lbs	Nm
4.5L	28	38

9. Install spark plug cables onto spark plug terminals.
10. Verify spark plug cables are captured in spark plug cable clips at top of valve cover.

Final Instructions

Proceed as follows if only performing Schedule A and Schedule B maintenance procedures:

1. Install negative battery cable (black) onto negative battery (-) terminal.
2. Install left and right side access panels. See [Access Panels](#).
3. See [Return To Service](#).

Schedule C Maintenance

NOTE: Perform Schedule C maintenance after 1,000 hours of service. Before proceeding below, first perform all tasks listed under Schedule A Maintenance and Schedule B Maintenance.

IMPORTANT NOTE: The following procedures require special tools and skills. Contact an IASD to perform these tasks.

1. Remove negative battery cable (black) from negative battery (-) terminal.
2. Proceed as follows:
 - Tighten critical fasteners.
 - Replace upper and lower radiator hoses.
 - Replace engine coolant bypass hoses.
 - Replace block heater hoses.

NOTE: Reset A-B-C/Year time maintenance schedule counter using Dealer Sub Menu (password required).

3. Install negative battery cable (black) onto negative battery (-) terminal.
4. Install front access panel. Install left and right side access panels. See [Access Panels](#).
5. See [Return To Service](#).

Return To Service

Proceed as follows to return the unit to service after inspection, maintenance, or service of the generator:

1. See [Figure 5-5](#). Pull up rubber flap (C) covering fuse holder and install 7.5 amp fuse.
2. Install T1 fuse in transfer switch.
3. Verify both auxiliary shutdown switches are ON (I). See [Figure 3-6](#) for locations.
4. Press AUTO on control panel. A green LED illuminates to verify system is in AUTO.
5. Set generator MLCB (generator disconnect) to ON (CLOSED).
6. Close viewing window.
7. Remove DO NOT OPERATE tag or placard from both the control panel and transfer switch.
8. Reset date/time.

Section 6: Troubleshooting

Engine Troubleshooting

Problem	Cause	Correction
Engine does not crank	Fuse blown.	Replace 7.5 amp fuse in generator control panel. Correct short circuit condition if fuse blows again.
	Loose, corroded, or faulty battery cables.	Tighten, clean, or replace as necessary. Contact an IASD.
	Faulty starter contact.	
	Faulty starter motor.	
	Discharged battery.	Charge or replace battery.
Engine cranks but will not start	Out of LP fuel.	Replenish LP fuel. Turn on fuel shutoff valve.
	Faulty fuel solenoid.	Contact an IASD.
	Open F1 7.5 amp fuse.	Replace F1 7.5 amp fuse if fuse blows again. Contact an IASD.
	Open F2 15 amp fuse.	Replace F2 15 amp fuse if fuse blows again. Contact an IASD.
	Faulty fuel system.	Contact an IASD.
	No fuel supply.	Turn on fuel supply. Contact an IASD.
Engine starts hard and runs rough	Air cleaner plugged or damaged.	Inspect/replace air cleaner.
Unit is set to OFF, but engine continues to run	Faulty keypad.	Contact an IASD.
	Faulty control board.	
No AC output from generator	Main line circuit breaker (MLCB) (generator disconnect) is OFF (OPEN).	Set MLCB (generator disconnect) to ON (CLOSED).
	Generator internal failure.	Contact an IASD.
No transfer to standby after utility source failure	Faulty transfer switch coil.	Contact an IASD.
	Faulty transfer relay.	
	Transfer relay circuit open.	
	Faulty control logic board.	
Unit consumes large amounts of oil	Engine over filled with oil.	Adjust oil to correct level.
	Faulty engine breather.	Contact an IASD.
	Incorrect oil type or viscosity.	See Engine Oil Recommendations .
	Damaged gasket, seal, or hose.	Inspect for oil leaks.

Controller Troubleshooting

Active Alarm	Problem	Solution
NOT ACTIVATED	Unit will not start in AUTO with utility loss.	See activation section in installation manual.
NONE	Unit running in AUTO but no power in house.	Check MLCB (generator disconnect). Contact an IASD if MLCB is set to ON.
NONE	Unit will not start in AUTO with utility loss.	Check LCD for start delay countdown. If startup delay is greater than expected, contact IASD to adjust from 2 to 1,500 seconds.
HIGH TEMPERATURE	Unit shuts down during operation.	Inspect ventilation around intake, exhaust, and rear of generator. Contact an IASD if no obstruction is found.
OVERLOAD	Unit shuts down during operation.	Clear alarm and remove loads from generator. Put back in AUTO and restart.
RPM SENSE LOSS	Unit was running and shuts down, attempts to restart.	Clear alarm and remove loads from generator. Put back in AUTO and restart. If problem returns, contact an IASD to investigate possible fuel issue.
LOW OIL PRESSURE	Unit will not start in AUTO with utility loss.	Check oil level. Add oil per owner's manual. Contact an IASD if oil level is correct.
RPM SENSE LOSS	Unit will not start in AUTO with utility loss.	Clear alarm. From MAIN menu on the control panel, navigate to BATTERY MENU. Contact an IASD if battery is GOOD. Replace battery if CHECK BATTERY is displayed.
OVERCRANK	Unit will not start in AUTO with utility loss.	Clear alarm. Attempt to start unit in MANUAL. If it does not start, or starts and runs rough, contact an IASD.
OVERSPEED	Unit will not start in AUTO with utility loss.	Contact an IASD.
UNDER VOLTAGE	Unit will not start in AUTO with utility loss.	
UNDER SPEED	Unit will not start in AUTO with utility loss.	
WIRING ERROR	Unit will not start in AUTO with utility loss.	
OVER VOLTAGE	Unit will not start in AUTO with utility loss.	
LOW BATTERY	Warning active.	Clear alarm. From MAIN menu on the control panel, navigate to BATTERY MENU. Contact an IASD if battery is GOOD. Replace battery if CHECK BATTERY is displayed.
BATTERY PROBLEM	Warning active.	Contact an IASD.
CHARGER WARNING	Warning active.	
SERVICE SCHEDULE A	Warning active.	Perform SERVICE SCHEDULE A maintenance; press ENTER to clear.
SERVICE SCHEDULE B	Warning active.	Perform SERVICE SCHEDULE B maintenance; press ENTER to clear.
SERVICE SCHEDULE C	Warning active.	Perform SERVICE SCHEDULE C maintenance; press ENTER to clear.
AUXILIARY SHUTDOWN	Unit will not start in AUTO with utility loss.	Verify both auxiliary shutdown switches are ON (I). See Figure 3-6 for locations.

Removal From Service During Utility Outage

If, during prolonged utility outages, the user wishes to remove unit from service to conserve fuel, reduce run hours, or to perform maintenance tasks, then complete the steps listed below.

IMPORTANT NOTE: Failure to abide by this procedure can result in equipment damage.

Proceed as follows to remove generator from service while running in AUTO and online:

1. Turn main utility disconnect to OFF (OPEN).
2. Open viewing window. See [Opening the Viewing Window](#).
3. Set generator MLCB (generator disconnect) to OFF (OPEN).
4. Press OFF on the control panel. A red LED illuminates to verify system is in OFF mode.

NOTE: Complete the additional steps listed below if inspection and/or maintenance tasks are to be performed.

5. Remove T1 fuse from transfer switch.
6. Pull up rubber flap covering fuse holder and remove 7.5 amp fuse.
7. Remove negative battery cable (black) from negative battery (-) terminal.
8. Place a DO NOT OPERATE tag or placard on both the control panel and transfer switch.

Return to Service During Utility Outage

Proceed as follows to return generator to service:

NOTE: Start with step 1 if inspection and/or maintenance tasks were performed. Start at step 5 if unit was only shut down to conserve fuel or to reduce run hours.

1. Install negative battery cable (black) onto negative battery (-) terminal.
2. Pull up rubber flap covering fuse holder and install 7.5 amp fuse.
3. Install T1 fuse in transfer switch.
4. Remove the DO NOT OPERATE tag or placard from both the control panel and transfer switch.
5. Press AUTO on control panel. A green LED illuminates to verify system is in AUTO mode. Allow generator to start and run for a few minutes.
6. Set generator MLCB (generator disconnect) to ON (CLOSED).
7. Set main utility disconnect to ON (CLOSED).
8. Close viewing window.

Storage

Prepare For Storage

Proceed as follows to prepare for storage if generator cannot be exercised every **seven** days and will be out of service longer than 90 days:

1. Open viewing window. See [Opening the Viewing Window](#).
2. Press MANUAL on control panel to start engine. A blue LED illuminates to verify system is in MANUAL.
3. Allow engine to run until it reaches normal operating temperature.
4. Press OFF on control panel. A red LED illuminates to verify system is OFF.
5. Set generator MLCB (generator disconnect) to OFF (OPEN).
6. Pull up rubber flap covering fuse holder and remove 7.5 amp fuse.
7. Turn off utility power to transfer switch.
8. Place a DO NOT OPERATE tag or placard on both the control panel and transfer switch.
9. Wait five minutes for engine to cool.
10. Remove left and right side access panels. See [Access Panels](#).
11. Remove oil drain hose from holding clamp.
12. Use one wrench to hold hex on oil drain hose fitting (to prevent rotation), and use second wrench to remove oil drain plug.
13. Drain oil into a suitable container.
14. Install oil drain plug onto end of oil drain hose.
15. Install oil drain hose into holding clamp.
16. Turn oil filter counterclockwise to remove from oil filter adapter.
17. Apply a light coat of clean engine oil to gasket of **new** oil filter.
18. Install oil filter by hand until gasket just contacts oil filter adapter. Tighten oil filter an additional three-quarters to one full turn.
19. Remove oil fill cap and fill engine with the recommended oil. See [Engine Oil Recommendations](#).
20. Install oil fill cap.

NOTE: Dispose of used oil and oil filter in accordance with local, state, or national laws.

Battery Removal



⚠ WARNING

Explosion. Batteries emit explosive gases. Always disconnect negative battery cable first to avoid spark. Failure to do so could result in death or serious injury. (000238)

Proceed as follows to remove the battery:

1. Remove negative battery cable (black) from negative battery (-) terminal.
2. Remove positive battery cable (red) from positive battery (+) terminal.
3. Remove two screws to release battery hold-down clamp from platform.
4. Remove battery and store in a cool, dry room.
5. Install left and right side access panels. See [Access Panels](#).
6. Thoroughly clean and wipe down generator. See [Corrosion Protection](#).

Return From Storage



⚠ WARNING

Explosion. Batteries emit explosive gases. Always connect positive battery cable first to avoid spark. Failure to do so could result in death or serious injury. (000133)

Proceed as follows to return unit to service after storage:

1. Thoroughly clean and wipe down generator. See [Corrosion Protection](#).
2. Remove left and right side access panels. See [Access Panels](#).
3. Install battery onto tray oriented with the negative (-) battery post toward the front of the enclosure.
4. Install two screws with nylon washers to secure battery hold-down clamp to tray.
5. Check battery. See [Checking Battery Condition/ Fluid Level](#).
6. Install positive battery cable (red) onto positive battery (+) terminal.
7. Install negative battery cable (black) onto negative battery (-) terminal.
8. Check oil level and add oil as necessary. **DO NOT OVERFILL.**
9. Open viewing window. See [Opening the Viewing Window](#).
10. Pull up rubber flap covering fuse holder and install 7.5 amp fuse.
11. Set generator MLCB (generator disconnect) to ON (CLOSED).

12. Press MANUAL on the control panel to start engine. A blue LED illuminates to verify system is in MANUAL.
13. Allow engine to run until it reaches normal operating temperature. Inspect for leaks while engine is running.
14. Press OFF on control panel. A red LED illuminates to verify system is OFF.
15. Install left and right side access panels. See [Access Panels](#).
16. Turn on utility power to transfer switch.
17. Press AUTO on control panel. A green LED illuminates to verify system is in AUTO.
18. Reset date/time.
19. Close the viewing window.

Attention After Submersion

Do NOT start and operate the generator if it has been submerged in water. Have an IASD thoroughly clean, dry, and inspect the generator following any submersion. If structure (home) has been flooded, it should be inspected by a certified electrician to verify there won't be any electrical problems during generator operation or when utility power is returned.

This page intentionally left blank.

Part No. A0000253468 Rev. B 07/6/2020
©2020 Generac Power Systems, Inc.
All rights reserved.
Specifications are subject to change without notice.
No reproduction allowed in any form without prior written
consent from Generac Power Systems, Inc.

GENERAC®

Generac Power Systems, Inc.
S45 W29290 Hwy. 59
Waukesha, WI 53189
1-888-GENERAC (1-888-436-3722)
www.generac.com