

Owner's Manual

Spark-Ignited Stationary Generators

Residential and Commercial

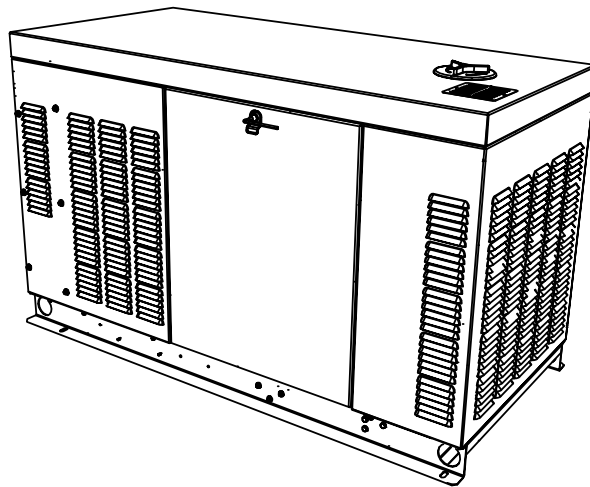

22 kW	2.4L
25 kW	1.5L
27 kW	2.4L
30 kW	1.5L
32 kW	2.4L
36 kW	2.4L
38 kW	2.4L
45 kW	2.4L
60 kW	2.4L



WARNING

Loss of life. This product is not intended to be used in a critical life support application. Failure to adhere to this warning could result in death or serious injury. (000209b)

Register your Generac product at:
WWW.GENERAC.COM
1-888-GENERAC
(888-436-3722)

Para español , visita: <http://www.generac.com/service-support/product-support-lookup>

Pour le français, visiter : <http://www.generac.com/service-support/product-support-lookup>

SAVE THIS MANUAL FOR FUTURE REFERENCE

Use this page to record important information about the generator set.

For quick and easy reference, copy the information printed on the Unit Identification Label onto the sample label printed here. The Unit Identification Label is located on the base frame adjacent to the front engine mount on all models.

When contacting an Independent Authorized Service Dealer (IASD) about parts and/or service, always provide the complete model number and serial number.

Operation and Maintenance: Proper maintenance and care of the generator ensures safe operation and longer service life while also keeping operating expenses to a minimum. It is the operator's responsibility to perform all safety checks, to make sure that all maintenance is performed promptly, and to have the equipment checked periodically by an Independent Authorized Service Dealer.

Normal maintenance, service and replacement of parts are the responsibility of the owner/operator, and are not considered defects in materials or workmanship within the terms of the warranty. Individual operating habits and usage may contribute to the need for additional maintenance or service.

When the generator requires servicing or repairs, contact an Independent Authorized Service Dealer for assistance. Authorized service technicians are factory-trained and are capable of handling all service needs.

When the generator requires servicing or repairs, the manufacturer recommends contacting an Independent Authorized Service Dealer (IASD) for assistance. Authorized service technicians are factory-trained and are capable of handling all service needs. To locate the nearest IASD, please visit the dealer locator at:

www.honeywellgenerators.com/find-a-dealer

<u>GENERATOR UNIT</u>			
GEN MODEL:			
MODEL:			
SERIAL:			
ALTERNATE			
PROD DATE:			
COUNTRY OF ORIGIN:			
<u>GENERATOR DATA</u>			
KW	KVA	HZ	PF
UPSIZE ALT	KW	KVA	
VOLT	/	AMP	
ENG RPM	ALT RPM		
BREAKER	KW	AMP	
X'D		X"D	
ROTOR	STATOR	CLASS	
WINDINGS @	AMBIENT TEMP		
		MANUF. LOC	

003564

Figure 1-1. Sample Label

**INDEPENDENT AUTHORIZED
SERVICE DEALER LOCATION**

To locate the nearest
INDEPENDANT AUTHORIZED SERVICE
DEALER,
please call this number:
1-800-333-1322

or visit the dealer locator at:
www.generac.com/Service/DealerLocator/

WARNING

CANCER AND REPRODUCTIVE HARM
www.P65Warnings.ca.gov

(000393a)

Table of Contents

Section 1: Safety

Introduction	1
Read This Manual Thoroughly	1
Safety Rules	1
How to Obtain Service	2
General Hazards	2
Exhaust Hazards	2
Fire Hazards	3
Electrical Hazards	3
Explosion Hazards	3
Battery Hazards	4

Section 2: General Information

Emissions	5
Emissions Data Plate	5
Specifications	6
Engine Oil Recommendations	8
Weather and Maintenance Kits	8
Coolant Water Treatment	8
Fuel Requirements	8
Reconfiguring the Fuel System	9
Fuel Conversion Procedure from NG to LPV	9
Change Fuel Selection	10
Battery Requirements	10
Battery Charger	10
Battery Safety Precautions	10
Corrosion Protection	10

Section 3: Activation and Startup

Orientation	11
Remove Side Access Panels	11
Install Battery	11
Open Viewing Window	12
Activate Unit	13
Start and Run Engine	14
Operational Checks	15
Self Test	15
Check Manual Transfer Switch Operation	15
Electrical Checks	15
Test Generator Under Load	16
Test Auxiliary Shutdown Switch Operation	16
Check Automatic Operation	16
Securing the Generator	17

Section 4: Operation

Control Panel	19
Auto/Manual/Off	19
Menu Navigation	20
Alarm / Warning Conditions	22
Change Time and Date	22
Programmable Timers	22
Dealer Programmable	22
User Programmable	22
USB Port for Firmware Updates	22
Battery Charger	23
Transfer Switch Automatic Operation	23
Automatic Sequence of Operation	23
Transfer Switch Manual Operation	24
Transfer to Generator Power	24
Transfer Back to Utility Power	25

Section 5: Maintenance

Component Locations 27

Access Panels 28

 Removal 28

 Installation 28

Maintenance 28

 Service Maintenance Schedule 29

Remove From Service 29

30 Hour Break-In 30

Daily Maintenance 30

Schedule A Maintenance 30

 Schedule A Maintenance Item Locations 30

 Preliminary Instructions 30

 Check Enclosure Louvers 30

 Check Fuel Lines 30

 Check Coolant Level and Hoses 30

 Check Radiator for Clogging 31

 Check Lubricating Oil Level and Drain Hose 31

 Replace Lubricating Oil and Oil Filter 32

 Check Battery Condition 34

 Installation 35

 Check and Adjust Accessory / Drive Belt 35

 Replace Air Filter Element 37

 Final Instructions 37

Schedule B Maintenance 37

 Schedule B Maintenance Item Locations 37

 Drain / Flush Coolant System 38

 Clean / Gap / Replace Spark Plugs 39

 Final Instructions 39

Schedule C Maintenance 40

Return To Service 40

Lube Oil Maintainer System 40

 Description 40

 Fill Oil Supply Tank 40

 Test Functionality 41

 Shutoff Valve 41

Section 6: Troubleshooting

Engine Troubleshooting 43

Controller Troubleshooting 44

Removal From Service During Utility Outages 45

Storage 45

 Prepare For Storage 45

 Return From Storage 46

Attention After Submersion 46

Section 1: Safety

Introduction

Thank you for purchasing this stationary automatic standby generator set. Every effort was made to ensure that the information in this manual was both accurate and complete at the time it was released. However, the manufacturer reserves the right to change, alter or otherwise improve this product at any time without prior notice.

This generator is designed to automatically supply electrical power to operate critical loads during a utility power failure. The unit is factory installed in an all-weather metal enclosure and **is intended exclusively for outdoor installation** using either Natural gas (NG) or Liquid Propane vapor (LPV).

NOTE: All 22 – 48 kW units are field convertible between NG or LPV, while 60 kW units are built per fuel requirements and are not field convertible.

When properly sized, the generator is suitable for supplying typical residential/commercial loads, such as induction motors (sump pumps, refrigerators, freezers, air conditioners, furnaces, etc.), electronic components (computers, monitors, televisions, etc.), lighting, microwaves, and other residential and business loads.

The information in this manual is accurate based on products produced at the time of publication. The manufacturer reserves the right to make technical updates, corrections, and product revisions at any time without notice.

Read This Manual Thoroughly



WARNING

Consult Manual. Read and understand manual completely before using product. Failure to completely understand manual and product could result in death or serious injury. (000100a)

If any section of this manual is not understood, contact the nearest Independent Authorized Service Dealer (IASD) or Generac Customer Service at 1-888-436-3722 (1-888-GENERAC), or visit www.generac.com for starting, operating, and servicing procedures. The owner is responsible for proper maintenance and safe use of the unit.

SAVE THESE INSTRUCTIONS for future reference. This manual contains important instructions that must be followed during placement, operation, and maintenance of the unit and its components. Always supply this manual

to any individual that will use this unit, and instruct them on how to correctly start, operate, and stop the unit in case of emergency.

Safety Rules

The manufacturer cannot anticipate every possible circumstance that might involve a hazard. The alerts in this manual, and on tags and decals affixed to the unit, are not all inclusive. If using a procedure, work method, or operating technique that the manufacturer does not specifically recommend, verify that it is safe for others and does not render the equipment unsafe.

Throughout this publication, and on tags and decals affixed to the unit, DANGER, WARNING, CAUTION, and NOTE blocks are used to alert personnel to special instructions about a particular operation that may be hazardous if performed incorrectly or carelessly. Observe them carefully. Alert definitions are as follows:

DANGER

Indicates a hazardous situation which, if not avoided, will result in death or serious injury.

(000001)

WARNING

Indicates a hazardous situation which, if not avoided, could result in death or serious injury.

(000002)

CAUTION

Indicates a hazardous situation which, if not avoided, could result in minor or moderate injury.

(000003)

NOTE: Notes contain additional information important to a procedure and will be found within the regular text of this manual.

These safety alerts cannot eliminate the hazards that they indicate. Common sense and strict compliance with the special instructions while performing the action or service are essential to preventing accidents.

How to Obtain Service

When the unit requires servicing or repairs, contact Generac Customer Service at 1-888-GENERAC (1-888-436-3722) or visit www.generac.com for assistance.

When contacting Generac Customer Service about parts and service, always supply the complete model and serial number of the unit as given on its data decal located on the unit. Record the model and serial numbers in the spaces provided on the front cover of this manual.

General Hazards

DANGER

Loss of life. Property damage. Installation must always comply with applicable codes, standards, laws and regulations. Failure to do so will result in death or serious injury. (000190)



WARNING

Loss of life. This product is not intended to be used in a critical life support application. Failure to adhere to this warning could result in death or serious injury. (000209b)

WARNING

Equipment damage. This unit is not intended for use as a prime power source. It is intended for use as an intermediate power supply in the event of temporary power outage only. Doing so could result in death, serious injury, and equipment damage. (000247a)

WARNING

Electric shock. Only a trained and licensed electrician should perform wiring and connections to unit. Failure to follow proper installation requirements could result in death, serious injury, and equipment or property damage. (000155a)



WARNING

Moving Parts. Keep clothing, hair, and appendages away from moving parts. Failure to do so could result in death or serious injury. (000111)



WARNING

Moving Parts. Do not wear jewelry when starting or operating this product. Wearing jewelry while starting or operating this product could result in death or serious injury. (000115)

WARNING

Risk of injury. Do not operate or service this machine if not fully alert. Fatigue can impair the ability to operate or service this equipment and could result in death or serious injury. (000215a)

WARNING

Accidental Start-up. Disconnect the negative battery cable, then the positive battery cable when working on unit. Failure to do so could result in death or serious injury. (000130)

WARNING

Injury and equipment damage. Do not use generator as a step. Doing so could result in falling, damaged parts, unsafe equipment operation, and could result in death or serious injury. (000216)

- Inspect the generator regularly, and contact the nearest Independent Authorized Service Dealer for parts needing repair or replacement.

Exhaust Hazards



DANGER

Asphyxiation. Running engines produce carbon monoxide, a colorless, odorless, poisonous gas. Carbon monoxide, if not avoided, will result in death or serious injury. (000103)



WARNING

Asphyxiation. Always use a battery operated carbon monoxide alarm indoors and installed according to the manufacturer's instructions. Failure to do so could result in death or serious injury. (000178a)

WARNING

Equipment and property damage. Do not alter construction of, installation, or block ventilation for generator. Failure to do so could result in unsafe operation or damage to the generator. (000146)

NOTE: The generator must be installed and operated outdoors only.

Fire Hazards



⚠ WARNING

Fire and explosion. Installation must comply with all local, state, and national electrical building codes. Noncompliance could result in unsafe operation, equipment damage, death, or serious injury.

(000218)



⚠ WARNING

Fire hazard. Use only fully-charged fire extinguishers rated “ABC” by the NFPA. Discharged or improperly rated fire extinguishers will not extinguish electrical fires in automatic standby generators.

(000219)

NOTE: Comply with regulations of the Occupational Safety and Health Administration (OSHA). Also, ensure that the generator is installed in accordance with the manufacturer’s instructions and recommendations. Following proper installation, do nothing that might alter a safe installation and render the unit in noncompliance with the aforementioned codes, standards, laws and regulations.

Electrical Hazards



⚠ DANGER

Electrocution. Contact with bare wires, terminals, and connections while generator is running will result in death or serious injury.

(000144)



⚠ DANGER

Electrocution. Water contact with a power source, if not avoided, will result in death or serious injury.

(000104)



⚠ DANGER

Electrocution. Do not wear jewelry while working on this equipment. Doing so will result in death or serious injury.

(000188)



⚠ DANGER

Electrocution. Never connect this unit to the electrical system of any building unless a licensed electrician has installed an approved transfer switch. Failure to do so will result in death or serious injury.

(000150)



⚠ DANGER

Electrocution. In the event of electrical accident, immediately shut power OFF. Use non-conductive implements to free victim from live conductor. Apply first aid and get medical help. Failure to do so will result in death or serious injury.

(000145)

Explosion Hazards



⚠ DANGER

Explosion and fire. Fuel and vapors are extremely flammable and explosive. No leakage of fuel is permitted. Keep fire and spark away. Failure to do so will result in death or serious injury.

(000192)

Battery Hazards



⚠ DANGER

Electrocution. Do not wear jewelry while working on this equipment. Doing so will result in death or serious injury.

(000188)



⚠ WARNING

Explosion. Do not dispose of batteries in a fire. Batteries are explosive. Electrolyte solution can cause burns and blindness. If electrolyte contacts skin or eyes, flush with water and seek immediate medical attention.

(000162)



⚠ WARNING

Explosion. Batteries emit explosive gases while charging. Keep fire and spark away. Wear protective gear when working with batteries. Failure to do so could result in death or serious injury.

(000137a)



⚠ WARNING

Electrical shock. Disconnect battery ground terminal before working on battery or battery wires. Failure to do so could result in death or serious injury.

(000164)



⚠ WARNING

Risk of burns. Batteries contain sulfuric acid and can cause severe chemical burns. Wear protective gear when working with batteries. Failure to do so could result in death or serious injury.

(000138a)



⚠ WARNING

Risk of burn. Do not open or mutilate batteries. Batteries contain electrolyte solution which can cause burns and blindness. If electrolyte contacts skin or eyes, flush with water and seek immediate medical attention.

(000163a)

⚠ WARNING

Environmental Hazard. Always recycle batteries at an official recycling center in accordance with all local laws and regulations. Failure to do so could result in environmental damage, death, or serious injury.

(000228)

Always recycle batteries in accordance with local laws and regulations. Contact your local solid waste collection site or recycling facility to obtain information on local recycling processes. For more information on battery recycling, visit the Battery Council International website at: <http://batteryCouncil.org>.

Section 2: General Information

Emissions

The United States Environmental Protection Agency (US EPA) (and California Air Resources Board (CARB), for engines/equipment certified to California standards) requires this engine/equipment to comply with exhaust and evaporative emissions standards. Locate the emissions compliance decal on the engine to determine applicable standards. See the included emissions warranty for emissions warranty information. Follow the maintenance specifications in this manual to ensure the engine complies with applicable emissions standards for the duration of the product's life.

Emissions Data Plate

A data plate is attached to the valve cover to verify compliance with EPA emissions regulations.

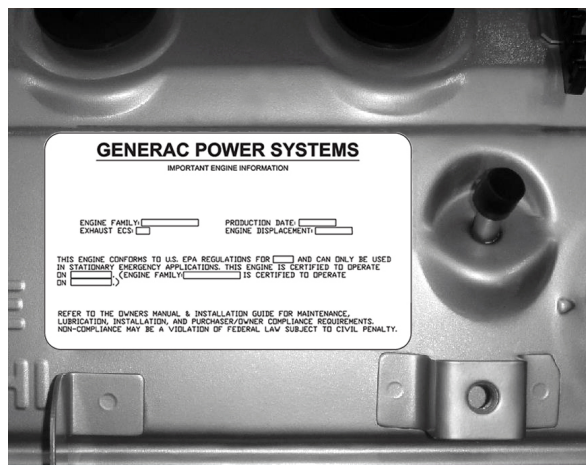

Figure 2-1. Emissions Data Plate (Sample)

Specifications

Model	22 kW	25 kW	27 kW	30 kW	32 kW	36 kW	38 kW	45 kW	60 kW	
Engine	2.4L	1.5L	2.4L	1.5L	2.4L	2.4L	2.4L	2.4L	2.4L	
Generator Set										
Rotor Insulation	Class H				Class F	Class H	Class F	Class H		
Stator Insulation	Class H									
Dimensions L x W x H	62.2 x 30.6 x 38.6				76.8 x 35 x 46.1					
Product Weight W/ Steel Enclosure—lbs (kg)	–	865 (392)	–	895 (406)	–		1,255 (569)		1,283 (582)	
Product Weight W/ Aluminum Enclosure—lbs (kg)	900 (408)	777 (352)	940 (426)	807 (366)	1,225 (556)	1,235 (560)	1,202 (545)		1,230 (558)	
Shipping Weight W/ Steel Enclosure—lbs (kg)	–	931 (422)	–	961 (436)	–		1,355 (615)		1,383 (627)	
Shipping Weight W/ Aluminum Enclosure—lbs (kg)	966 (438)	843 (382)	1,006 (456)	873 (396)	1,325 (601)	1,335 (606)	1,302 (590.6)		1,330 (603)	
Engine System										
Type	In-Line									
Dry Weight—lbs (kg)	287 (130)	243 (110)	287 (130)	243 (110)	287 (130)					
Bore (in / mm)	3.41 / 86.5	3.05 / 77.4	3.41 / 86.5	3.05 / 77.4	3.41 / 86.5					
Stroke (in / mm)	3.94 / 100	3.13 / 79.5	3.94 / 100	3.13 / 79.5	3.94 / 100					
Displacement (liters)	2.4	1.5	2.4	1.5	2.4					
Firing Order	1-3-4-2									
Direction or Rotation	CW From Flywheel									
Compression Ratio	9.5:1	11:1	9.5:1	11:1	9.5:1					
Spark Plug Gap (mm)	1.07 – 1.17	0.9	1.07 – 1.17	0.9	0.71	1.07 – 1.17	0.71	1.07 – 1.17	0.71	
Rated Synchronous RMP	1,800	3,600	1,800	3,600	1,800	3,600	1,800	3,600		
Cooling System										
Water Pump	Belt Driven									
Fan Speed (rpm)	1,980	2,484	1,980	2,484	1,500	1,865	1,500	1,865	2,100	
Fan Diameter (inches / cm)	18.1 / 46	17.7 / 45	18.1 / 46	17.7 / 45	22.0 / 56					
Fan Mode	Pusher				Puller					
Air Flow (ft ³ /min.)	2,400	2,490	2,400	2,490	2,200	2,725	2,200	2,725	3,280	
Coolant Capacity (gallons / liters)	2.5 / 9.5	2.0 / 7.6	2.5 / 9.5	2.0 / 7.6	2.5 / 9.5					
Heat Rejection to Coolant (Btu/h)	99,000	112,000	105,000	135,000	145,000	193,000	145,000	193,000	270,000	
Max Operating Air Temp on Radiator	150° F (60° C)									
Max Ambient Temp	140° F (50° C)									
Thermostat (Full Open)	190° F (88° C)									

Model	22 kW	25 kW	27 kW	30 kW	32 kW	36 kW	38 kW	45 kW	60 kW
Engine	2.4L	1.5L	2.4L	1.5L	2.4L	2.4L	2.4L	2.4L	2.4L
Lubricating System									
Oil Pump Type	Gear								
Oil Filter Type	Full Flow Spin-on Cartridge								
Crankcase Oil Capacity (quarts / liters)	4 / 3.8								
Lubricating Oil Type	5W-20								
Air Intake System									
Type	Naturally Aspirated				Turbo/ Aftercooled	Naturally Aspirated	Turbo/ Aftercooled	Naturally Aspirated	Turbo/ Aftercooled
Exhaust System									
Breather	Closed				Open	Closed	Open	Closed	Open
Exhaust Flow at Rated Output 60 Hz	165 cfm	203 cfm	180 cfm	237 cfm	300 cfm	420 cfm	300 cfm	420 cfm	494 cfm
Exhaust Temperature at Rated Output	900° F (482° C)	1,100° F (593° C)	1,000° F (538° C)	1,130° F (610° C)	1,075° F (579° C)	1,100° F (593° C)	1,075° F (579° C)	1,100° F (593° C)	1,050° F (566° C)
Electrical System									
Battery Charge Alternator	12 V, 30 Amp	12 V, 15 Amp	12 V, 30 Amp	12 V, 15 Amp	12 V, 30 Amp				
Recommended Battery	Group 26 077483S						Group 24F 058208S	Group 26 077483S	
Static Battery Charger	2.5 Amp								
Governor System									
Type	Electronic								
Frequency Regulation	Isochronous								
Steady State Regulation	+/- 0.25%								
Voltage Regulator									
Type	Electronic								
Sensing Phase	Single								
Regulation	+/- 1%								
Fuel System									
LP Fuel Pressure	11 – 14" WC								
NG Fuel Pressure	3.5 – 14" WC								

Engine Oil Recommendations

To maintain the product warranty, engine oil should be serviced in accordance with the recommendations of this manual. For your convenience, Generac Maintenance Kits are available that include engine oil, oil filter, air filter, spark plug(s), a shop towel, and a funnel. These kits can be obtained from an Independent Authorized Service Dealer (IASD).

This unit is filled at the factory with 5W-20 engine oil. After the 30 hour break in, replace the oil with Generac proprietary 5W-20 Synthetic oil. Once synthetic oil is used, it should be used for the life of generator. It is not recommended to go back to a mineral oil. Do not use special additives.

NOTE: If not already equipped, it is strongly recommended to use optional Cold Weather Start Kit for temperatures below 32°F. Utilize the Generac proprietary blended 5W-20 oil in all climates.

Weather and Maintenance Kits

To keep generator running at its peak, the following kits are offered:

- Cold Weather Kit
 - Recommended for climates with temperatures below 32°F.
- Extreme Cold Weather Kit
 - Recommended Block Heater Kit for protection in temperatures below 32°F.
- Scheduled Maintenance Kit
 - Kit includes recommended parts to maintain generator. Refer to the [Service Maintenance Schedule](#) for regular maintenance intervals.

For additional information, or to order any of these kits, please contact an IASD or Customer Service Representative.

Coolant Water Treatment

Use of improper coolants can damage the engine cooling system. Use demineralized water or distilled water for best results. Hard water causes scale deposits, which reduces cooling efficiency and raises internal temperatures, possibly leading to engine damage. Use an anti-corrosive to prevent rot in summer and anti-freeze to prevent freezing in winter.

Dilute the anti-freeze based on a theoretical temperature that is 9 – 18°F (5 – 10°C) below the lowest temperature expected in the area. A ratio of 40 – 60% is most common range.

Freezing Point °F (°C)	-13 (-25)	-31 (-35)	-58 (-50)
Coolant (% Volume)	40	50	60
Water (% Volume)	60	50	40

NOTE: Use only Generac 50/50 ethylene glycol type coolant (available from any IASD).

IMPORTANT NOTE: Do not use propylene glycol type coolant. Using the wrong coolant, mixing different types of coolant, or even mixing different brands of the correct type of coolant, can produce unsatisfactory results, possibly leading to engine damage.

Fuel Requirements

The Stationary Emergency Generator may be equipped with one of the following fuel systems:

- Natural Gas Fuel System
- Propane Vapor (LPV) fuel system

Recommended fuels must have a BTU content of at least 1,000 BTUs per cubic foot (37.26 megajoules per cubic meter) for NG, or at least 2,520 BTUs per cubic foot (93.8 megajoules per cubic meter) for LPV. If converting to LPV from NG, a minimum LP tank size of 250 gallons (946 liters) is recommended. See the Installation Manual for complete details and procedures.

Reconfiguring the Fuel System

While some models are created fuel specific for either Natural gas (NG) or Liquid Propane vapor (LPV) and are not fuel convertible, others are configured at factory for NG, but are field convertible to LPV. Units fitted with a dual fuel carburetion system are generally configured for selected fuel source during installation.

To reconfigure fuel system, change jet in demand regulator, and then navigate to appropriate menu to assign new fuel type. Before proceeding, be aware that the fuel conversion software is password protected.

NOTE: Generac recommends fuel conversion be done by an IASD or a qualified, competent installation contractor or electrician who is familiar with applicable codes, standards, and regulations.

Fuel Conversion Procedure from NG to LPV

1. Turn off the main gas supply.
2. Remove battery negative cable (black) from battery negative (-) terminal.
3. See [Figure 2-2](#). Remove carburetor fuel hose from outlet port.
4. Remove screw at front of power wire connector and pull connector from fuel solenoid.
5. Expand spring clamp on fuel enrichment hose and remove from hose barb.

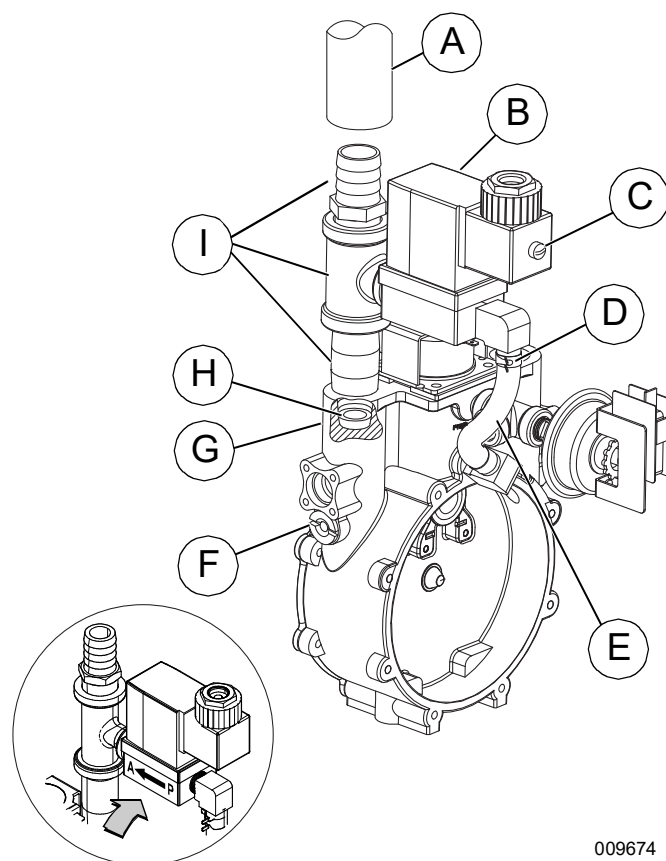

009674

Figure 2-2. Demand Regulator Assembly

A Carburetor Fuel Hose	F Jet Keeper Port
B Solenoid Body	G Outlet Port
C Connector Screw	H Fuel Jet
D Spring Clamp	I Black Pipe Assembly
E Fuel Enrichment Hose	

6. Remove black pipe assembly from outlet port. If clearance is not sufficient, first remove fuel solenoid assembly.
7. Rotate NG fuel jet counterclockwise to remove from outlet port.

NOTE: Both NG and LP fuel jets are slotted so they may be removed and installed using an ordinary flat blade screwdriver.

8. Rotate LP fuel jet counterclockwise to remove from jet keeper port.

NOTE: The orifice size is stamped on each jet. Jet with larger orifice is used for running on NG.

9. Rotate LP fuel jet clockwise to install in outlet port.
10. Rotate NG fuel jet clockwise to install in jet keeper port.
11. Install fuel solenoid assembly, if removed.

NOTE: Solenoid must be installed with flow arrow pointed toward black pipe assembly. See inset of [Figure 2-2](#).

12. Apply appropriate pipe sealant to threads of black pipe assembly and install into outlet port.
13. Expand spring clamp on fuel enrichment hose and install onto hose barb.
14. Push power wire connector onto fuel solenoid and install screw.
15. Install carburetor fuel hose onto outlet port.
16. Install negative battery cable (black) onto negative (-) battery terminal.
17. Turn on main gas supply.
18. See [Change Fuel Selection](#).

Change Fuel Selection

NOTE: Failure to convert both the hardware and software will result in decreased performance and an increase in emissions, which is a violation of Environmental Protection Agency (EPA) regulations. It is the responsibility of the installer to make sure only the correct recommended fuel is supplied to the generator fuel system. Thereafter, the owner / operator must ensure that only the proper fuel is supplied.

1. Selecting the correct fuel type occurs during the [Activate Unit](#) process.

Battery Requirements

Group 26, 12 Volt	1.5L, 2.4L Engines: For areas where temperatures regularly drop below 32° F (0° C). Part number 077483S.
NOTE: Battery dimensions (L x W x H) for Group 26 battery must not exceed 8-3/16 in x 6-13/16 in x 7-3/4 in (208 mm x 173 mm x 197 mm).	
Group 24F, 12 Volt	5.4L Engine: For areas where temperatures regularly drop below 32° F (0° C). Part number 058208S.
NOTE: Battery dimensions (L x W x H) for Group 24F battery must not exceed 10-3/4 in x 6-13/16 in x 9 in (273 mm x 173 mm x 229 mm).	

Battery Charger

A 2.5 amp battery charger is integrated into the control panel module. It operates as a “Smart Charger” which ensures output charging levels are safe and continuously optimized to promote maximum battery life.

Battery Safety Precautions

Always recycle batteries in accordance with local laws and regulations. Contact your local solid waste collection site or recycling facility to obtain information on local recycling processes. For more information on battery recycling, visit the Battery Council International website at: <http://batterycouncil.org>.

- Stationary emergency generators installed with automatic transfer switches will crank and start automatically when NORMAL (UTILITY) source voltage is removed or is below an acceptable preset level. To prevent automatic startup and possible injury to personnel, do not connect battery cables until NORMAL source voltage at the transfer switch is correct and the system is ready to be placed into operation.
- Storage batteries give off EXPLOSIVE hydrogen gas. This gas can form an explosive mixture around the battery for several hours after charging. The slightest spark can ignite the gas and cause an explosion. An explosion can shatter the battery and cause blindness or other injury. Any area that houses a storage battery must be properly ventilated. Do not allow smoking, open flame, sparks, or any spark producing tools or equipment near the battery.
- When working on the battery, always remove watches, rings, or other metal objects, and only use tools that have insulated handles. Do not lay tools or metal parts on top of the battery.
- Discharge static electricity from the body before touching the battery by first touching a grounded metal surface.
- Wear full eye protection, protective clothing, and gloves when handling a battery.
- Immediately wash down spilled electrolyte with an acid neutralizing agent. Use a solution of 1 pound (500 grams) bicarbonate of soda to 1 gallon (4 liters) of water. Add the bicarbonate of soda solution until evidence of reaction (foaming) has ceased. Flush the resulting liquid with water.

Corrosion Protection

Periodically wash and wax the enclosure using automotive type products. Frequent washing is recommended in salt water / coastal areas. Use All Surface Protectant (part number A000019001) on all vinyl, rubber, and plastics to create a barrier that seals and protects the surface from water and UV rays.

Section 3: Activation and Startup

Orientation

NOTE: The 2.4L (32 kW) unit is depicted in the artwork used in this manual. The location and appearance of some components may vary between engine models.

The side of the enclosure with the viewing window (A) is identified as the rear of the generator set. The right and left sides are identified by standing at the rear and looking towards the front of the unit. The battery is located on the side of the unit (B).

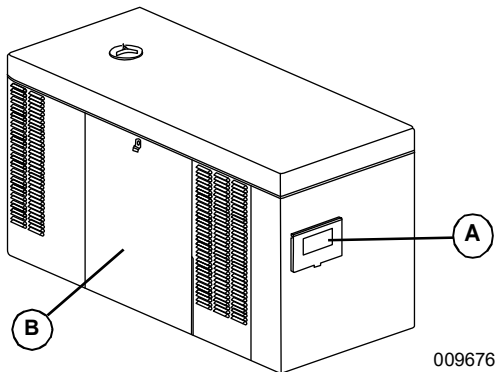

Figure 3-1. Enclosure (Rear Left View)

Remove Side Access Panels

NOTE: Access panels are located at both the left and right sides of the enclosure.

1. Remove key from bag attached to door of unit.
2. See [Figure 3-2](#). Insert key (B) into latch (A) and rotate counterclockwise 1/2 turn.
3. Raise panel using thumb latch.

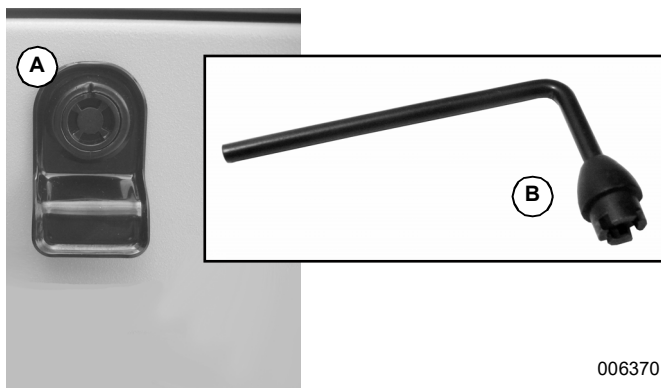

Figure 3-2. Access Panel Key and Latch (Typical)

Install Battery



WARNING

Explosion. Batteries emit explosive gases. Always connect positive battery cable first to avoid spark. Failure to do so could result in death or serious injury. (000133)

1. Loosen the two screws with the nylon washers to release hold-down clamp from battery tray.
2. See [Figure 3-3](#). Install battery (C) onto tray.
3. Install the two screws with the nylon washers to secure hold-down clamp to battery tray.
4. Install positive battery cable (red) (A) to positive (+) battery terminal.
5. Install negative battery cable (black) (B) to negative (-) battery terminal.

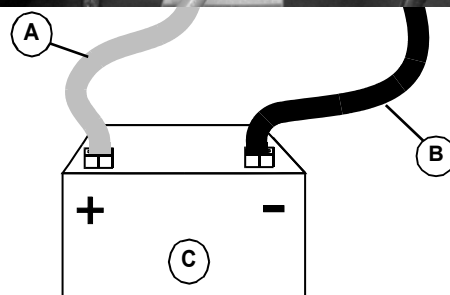
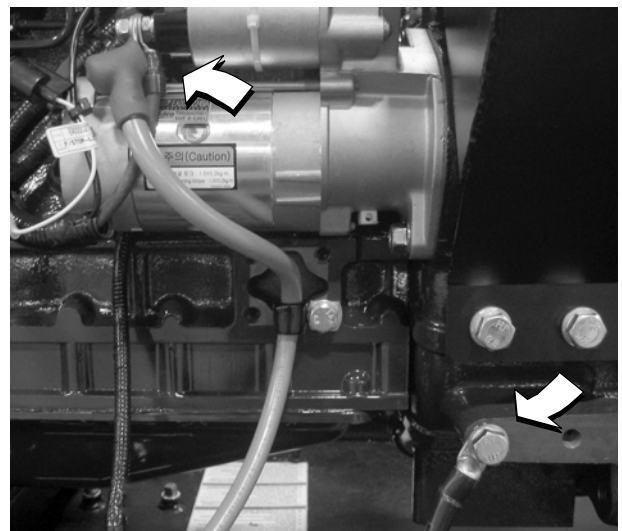

006372

Figure 3-3. Battery Cable Connections

Open Viewing Window

1. See **Figure 3-4**. Remove plastic film from both sides of viewing window.
2. Rotate viewing window upward to access control panel.
3. To hold viewing window in the open position, remove rod from clip at back of window and insert into hole in frame (A).

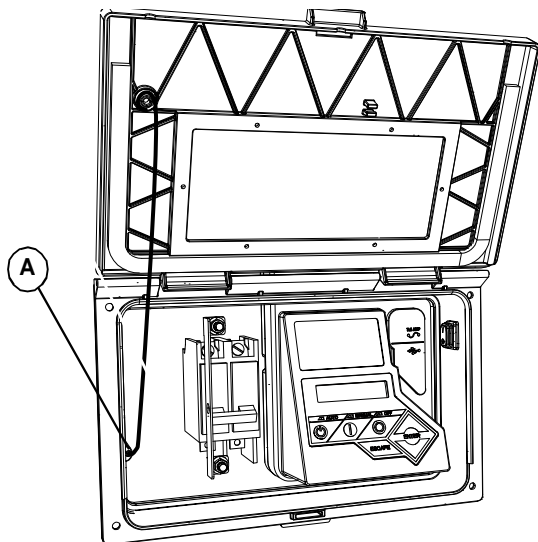

006373

Figure 3-4. Viewing Window

Activate Unit

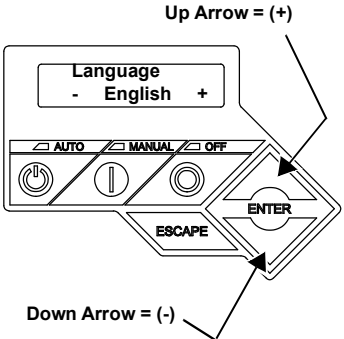
<p>Display Reads:</p> 	<p>Generator Active is displayed on the LCD screen when the unit is first powered up. After displaying firmware and hardware version codes, as well as other system information, the Installation Wizard is launched, and the Language screen is displayed.</p> <p>Use UP ARROW or DOWN ARROW to scroll to desired language.</p> <p>Press ENTER.</p>	<p>If the wrong language is selected, it may be changed later using the Edit menu.</p>
<p>Display Reads:</p> <div style="border: 1px solid black; padding: 5px; text-align: center;"> <p>Activate me (ENT) or ESC to run in manual</p> </div>	<p>Press ENTER.</p>	<p>Press ESCAPE to abort the activation sequence. NOT ACTIVATED is displayed and the generator will run in manual mode only. Disconnect and reconnect the negative battery cable to restart the activation routine. If power is removed after a successful activation, no data is lost, but the time and date must be updated.</p>
<p>Display Reads:</p> <div style="border: 1px solid black; padding: 5px; text-align: center;"> <p>To Activate go to www.activategen.com</p> </div>	<p>Go to www.activategen.com or call 1-888-9ACTIVATE (922-8482, US & Canada only) if activation passcode is not available.</p> <p>If activation passcode is available, wait a few seconds for the next display.</p>	
<p>Display Reads:</p> <div style="border: 1px solid black; padding: 5px; text-align: center;"> <p>SN 1234567890 PASS CODE XXXXX</p> </div>	<p>Use UP ARROW or DOWN ARROW to increment or decrement the digit to correspond to the first number of the passcode.</p> <p>Press ENTER.</p> <p>Repeat step to enter remaining digits.</p>	<p>Press ESCAPE to return to preceding digits if a correction becomes necessary.</p> <p>If attempts to enter the activation code are unsuccessful, check the number against the code given on activategen.com. If it is correct, contact 1-888-9ACTIVATE (922-8482, US & Canada only). For international assistance, call 01-262-953-5155.</p>
<p>Display Reads:</p> <div style="border: 1px solid black; padding: 5px; text-align: center;"> <p>Select Hour (0-23) - 6 +</p> </div>	<p>Use UP ARROW or DOWN ARROW to increment or decrement the hour. Press ENTER.</p> <p>Use UP ARROW or DOWN ARROW to increment or decrement the minute. Press ENTER.</p> <p>Use UP ARROW or DOWN ARROW to select the month. Press ENTER.</p> <p>Use UP ARROW or DOWN ARROW to increment or decrement the date. Press ENTER.</p> <p>Use UP ARROW or DOWN ARROW to increment or decrement the year. Press ENTER.</p>	

<p>Display Reads:</p> <div style="border: 1px solid black; padding: 10px; text-align: center;"> <p>Quiet Test Mode? Yes No</p> </div>	<p>Use UP ARROW or DOWN ARROW to select either Yes or No.</p> <p>Press ENTER.</p>	<p>Select YES to perform exercise at low speed. Select NO to perform exercise at normal operating speed.</p>
<p>Display Reads:</p> <div style="border: 1px solid black; padding: 10px; text-align: center;"> <p>Select Hour (0-23) - 1 +</p> </div>	<p>Set Exercise Time.</p> <p>Use UP ARROW or DOWN ARROW to increment or decrement the hour. Press ENTER.</p> <p>Use UP ARROW or DOWN ARROW to increment or decrement the minute. Press ENTER.</p> <p>Use UP ARROW or DOWN ARROW to scroll to the day of the week. Press ENTER.</p>	<p>In the AUTO mode, the engine starts and runs once each week at the time and day specified. During the exercise cycle, the unit runs approximately 12 minutes and then shuts down. Transfer of loads to the generator does not occur unless utility power fails.</p>
<p>Display Reads:</p> <div style="border: 1px solid black; padding: 10px; text-align: center;"> <p>Fuel Selection - LP + - NG +</p> </div>	<p>Fuel Type Selection</p> <p>Use UP or DOWN arrow to index to the fuel type.</p> <p>Press ENTER.</p> <p>Select the correct fuel based on the fuel connected at the installation site.</p>	

Start and Run Engine

1. See [Figure 3-5](#). Pull up rubber flap covering fuse holder and verify installation of 7.5 amp fuse (A).
2. Move Main Circuit Breaker switch down to OFF (Open) position (B).
3. Verify both auxiliary shutdown switches are ON (I). See [Figure 3-6](#) for locations.
4. Press MANUAL on control panel (C) to start engine. A blue LED will illuminate to confirm system is in MANUAL mode.
5. Allow engine to run until it reaches normal operating temperature.
6. Press OFF on control panel to stop engine. A red LED will illuminate to confirm system is in OFF mode.

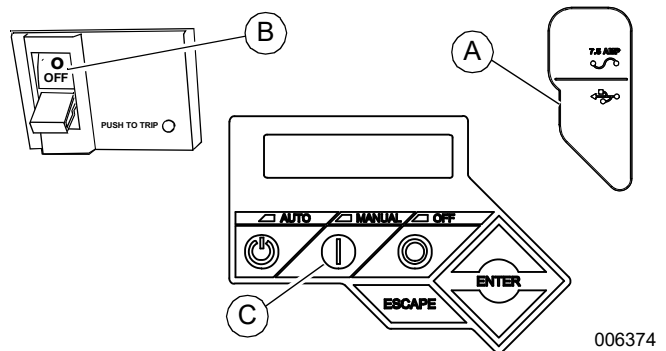

Figure 3-5. Generator Control Panel

Operational Checks

NOTE: The following procedures require special tools and skills. Contact an IASD to perform these tasks.

Self Test

Upon power up, the controller goes through a system self test which checks for the presence of utility voltage on the DC circuits. This is done to prevent damage if the installer mistakenly connects AC utility power sense wires into the DC terminal block. If utility voltage is detected, the controller displays a warning message and locks out the generator, thereby preventing damage to the controller. Remove power to the controller to clear this warning.

Utility voltage must be turned on and present at N1 and N2 terminals inside the generator control panel for this test to be performed and pass.

Before starting, complete the following:

1. Verify generator is OFF. A red LED on control panel will illuminate to confirm system is in OFF mode.
2. Verify Main Circuit Breaker switch on generator control panel is in OFF (Open) position.
3. Turn off all circuit breakers / electrical loads that will be powered by generator.
4. Verify both auxiliary shutdown switches are ON (I). See [Figure 3-6](#) for locations.
5. Check coolant and engine lubricating oil levels. See [Check Coolant Level and Hoses](#) and [Check Lubricating Oil Level and Drain Hose](#).

During initial start up only, the generator may exceed the normal number of start attempts and experience an “over crank” fault. This is due to accumulated air in the fuel system during installation. Reset the control board and restart up to two more times, if necessary. If unit fails to start, contact an IASD for assistance.

Check Manual Transfer Switch Operation

Refer to the manufacturer’s instructions.



⚠ DANGER

Electrocution. Do not manually transfer under load. Disconnect transfer switch from all power sources prior to manual transfer. Failure to do so will result in death or serious injury, and equipment damage.

(000132)

Electrical Checks

Complete electrical checks as follows:

1. Verify generator is OFF. A red LED on the control panel will illuminate to confirm system is in OFF mode.

2. Verify Main Circuit Breaker switch on generator control panel is in OFF (Open) position.
3. Turn OFF all circuit breakers / electrical loads that will be powered by generator.
4. Turn on utility power supply to transfer switch using means provided (such as a utility main line circuit breaker).



⚠ DANGER

Electrocution. High voltage is present at transfer switch and terminals. Contact with live terminals will result in death or serious injury.

(000129)

5. Use an accurate AC voltmeter to check utility power source voltage across transfer switch terminals N1, N2, and N3 (if three phase). Normal line-to-line voltage should be equivalent to rated unit voltage.
6. Check utility power source voltage across terminals N1, N2, and N3 (if three phase) and transfer switch neutral lug.
7. When certain utility supply voltage is compatible with transfer switch and load circuit ratings, turn OFF utility power supply to transfer switch.
8. Press MANUAL on control panel to crank and start engine.
9. Allow engine to warm up for about five minutes. Move Main Circuit Breaker switch on generator control panel up to ON (or closed) position.
10. Connect an accurate AC frequency meter across transfer switch terminal lugs E1, E2, and E3 (if three phase) and verify proper rated frequency (50 Hz or 60 Hz).
11. Use an accurate AC voltmeter to check generator output voltage across transfer switch terminals E1 to E2, (E2 to E3 and E3 to E1 if three phase). Normal line-to-line voltage should be equivalent to site specific utility voltage.
12. Successively connect the AC voltmeter test leads across terminal lugs E1 and Neutral, then E2 and Neutral (and E3 and Neutral if three phase). Line-to-neutral reading in each case should match utility voltage reading. If system is three phase, verify generator phase rotation matches utility phase rotation.
13. Move Main Circuit Breaker switch on generator control panel down to OFF (Open) position.
14. Press OFF on control panel to shut engine down.

NOTE: Do not proceed unless certain that generator AC voltage and frequency are correct and within stated limits.

Test Generator Under Load

To test generator set with electrical loads applied, proceed as follows:

1. Verify generator is OFF. A red LED on the control panel will illuminate to confirm system is in OFF mode.
2. Turn OFF all breakers / electrical loads that will be powered by generator.
3. Turn OFF utility power supply to transfer switch, using means provided (such as a utility main line circuit breaker).



⚠ DANGER

Electrocution. Do not manually transfer under load. Disconnect transfer switch from all power sources prior to manual transfer. Failure to do so will result in death or serious injury, and equipment damage.

(000132)

4. Manually set transfer switch to STANDBY position, i.e., load terminals connected to generator's E1, E2, and E3 (if three phase) terminals.
5. Press MANUAL on control panel. Engine will crank and start.
6. Allow engine to warm up for a few minutes.
7. Move Main Circuit Breaker switch on generator control panel up to ON (or closed) position. The switch is now powered by standby generator.
8. Turn ON circuit breaker / electrical loads powered by generator.
9. Connect a calibrated AC voltmeter and a frequency meter across terminal lugs E1, E2, and E3 (if three phase). Voltage should be approximately unit rated voltage. Check with clamp on amp meter to ensure unit is not overloaded.
10. Let generator run at full rated load for 20 – 30 minutes. Listen for unusual noises, vibration, or other indications of abnormal operation. Check for oil leaks, evidence of overheating, etc.
11. When testing under load is complete, turn OFF electrical loads.
12. Move Main Circuit Breaker switch on generator control panel up to OFF (or open) position.
13. Allow engine to run at no-load for 2 – 5 minutes.
14. Press OFF on control panel to shut engine down. A red LED will illuminate to confirm system is in OFF mode.

Test Auxiliary Shutdown Switch Operation

The generator is equipped with an independent means of shutting down prime mover (engine) for use in emergency situations. The shutdown mechanism, when activated, requires a mechanical reset.

See [Figure 3-6](#). Generators 15 kW and larger are equipped with two auxiliary shutdown switches. One auxiliary shutdown switch (A) is located on the generator roof above and to the right of the viewing window. The second auxiliary shutdown switch (B) is inside the control panel enclosure.

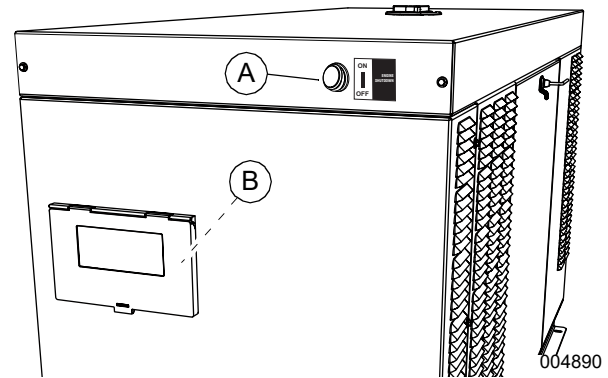

Figure 3-6. Auxiliary Shutdown Switches

Test auxiliary shutdown switches after installation to verify correct operation.

1. Verify auxiliary shutdown switches are ON (I).
2. Press MANUAL key on control panel keypad to start engine.
3. With engine running, set one auxiliary shutdown switch to OFF (O). Engine should shut down immediately.
 - **If engine stops**, set auxiliary shutdown switch to ON (I), clear alarm on controller, and restart engine to verify generator is operating normally. After verifying normal operation of first auxiliary switch, verify operation of second auxiliary switch.
 - **If engine does not stop**, auxiliary shutdown switch is not functioning correctly. Contact an IASD.

NOTE: Auxiliary shutdown switches are not intended to be a primary means to shut down generator under normal operating conditions. Accidental activation of an auxiliary shutdown switch will prevent generator from operating during a power outage.

Check Automatic Operation

To check system for proper automatic operation, proceed as follows:

1. Verify generator is OFF. A red LED on control panel will illuminate to confirm system is in OFF mode.
2. Install front cover of transfer switch.
3. Turn ON utility power supply to transfer switch, using means provided (such as a utility main line circuit breaker).

NOTE: Transfer Switch will transfer back to utility position.

4. Move Main Circuit Breaker switch on generator control panel up to ON (or closed) position.
5. Press AUTO on control panel. System is now ready for automatic operation.
6. Turn OFF utility power supply to transfer switch.

With the generator ready for automatic operation, the engine will crank and start when the utility source power is turned OFF after a 10 second delay (factory default setting). After starting, the transfer switch connects load circuits to the standby side. Let the system operate through its entire automatic sequence of operation.

With the generator running and loads powered by generator AC output, turn ON the utility power supply to the transfer switch. The system transfers back to the utility position and then runs through the cool down cycle and shuts down.

Securing the Generator

1. Use key to install left and right side access panels.
2. Close viewing window.

NOTE: Obtain viewing window hasp, if not installed. See [Figure 3-7](#). With retaining tab at the bottom, insert square end of hasp into slot below viewing window. Push on hasp until it snaps in place. Gently pull on hasp to verify that it will not come free.

3. Install customer supplied padlock into hasp.



006376

Figure 3-7. Install Viewing Window Hasp

This page intentionally left blank.

Section 4: Operation

Control Panel

NOTE: The control panel is intended for use by qualified service personnel only.

The control panel is located behind the viewing window at the rear of unit. See [Figure 3-5](#) and [Figure 4-1](#).

⚠ DANGER

Automatic start-up. Disconnect utility power and render unit inoperable before working on unit. Failure to do so will result in death or serious injury.

(000191)

NOTE: For added security, place a DO NOT OPERATE tag or placard on both control panel and transfer switch.

Auto/Manual/Off

Feature	Description
AUTO	Press to activate fully automatic operation. Green LED will illuminate to confirm system is in AUTO mode. Transfer to standby power occurs if utility power fails. Functionality of exercise timer is enabled, if set.
MANUAL	Press to crank and start engine. Blue LED will illuminate to confirm system is in MANUAL mode. Transfer to standby power occurs if utility power fails. Functionality of exercise timer is disabled.
OFF	Press to shut down engine, if running. Red LED will illuminate to confirm system is in OFF mode. Transfer to standby power does not occur if utility power fails.

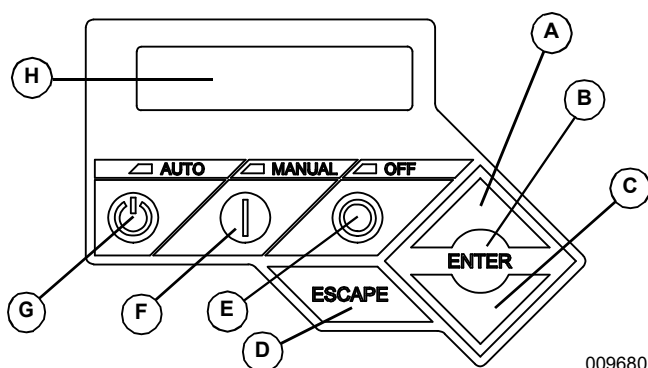

A	Up Arrow
B	Enter
C	Down Arrow
D	Escape
E	Off
F	Manual
G	Auto
H	LCD Screen

Figure 4-1. Control Panel and LCD Screen

Menu Navigation

See [Figure 4-2](#).

Feature	Description
System Menus	
HOME Screen	The system will return to the Home screen if the control panel is not used for five minutes. The screen normally displays a Status message, such as Ready to Run (Auto mode) or Switched to OFF (Off mode), and the total Hours of Protection. If an active alarm / warning condition occurs, the associated Alarm / Warning message is displayed. To clear the Alarm / Warning message, press OFF on control panel followed by ENTER. In the event of multiple Alarms / Warnings, the next message is then displayed. The highest priority alarm is always displayed first.
Display Backlight	Normally off. If operator presses any button, backlight will automatically light and remain on for 30 seconds.
MAIN MENU	Enables operator to navigate software using UP ARROW, DOWN ARROW, ENTER, and ESCAPE. The Main Menu can be accessed from any sub menu by consecutively pressing ESCAPE. Each time ESCAPE is pressed, the preceding menu is displayed. Main Menu is reached when System, Date / Time, Battery, and Sub Menus are displayed.
SUB-MENUS	The Sub-Menus screen includes HISTORY, MAINT, EDIT, AND DEALER menus.
HISTORY	The HISTORY screen includes an Alarm Log and Run Log. The Alarm Log displays the last 50 alarm events. The Run Log displays the last 50 operational events.
MAINTENANCE MENU	Includes Run Hours, Maintenance Log, and Schedule. Run Hours displays cumulative hours on engine. Maintenance Log displays the last service warnings and service completions. Scheduled displays when the next scheduled maintenance interval warning will occur.
EDIT MENU	Includes Language, Current Date / Time, Exercise Settings, Firmware Update, Startup Delay, and Warm up Time. All of these settings are adjustable without a password.
DEALER MENU	Includes settings that are password protected and can be adjusted by an Independent Authorized Service Dealer during installation or a service visit.
Navigation	
ESCAPE	Used to abort a routine or back up to preceding menu.
ENTER	Used to make a selection or save an entry.
UP ARROW DOWN ARROW	Used to move forward or backward from menu to menu or to scroll forward or backward (increment or decrement) through available selections.
NOTE: Pressing the control panel illuminates the backlight for 30 seconds. The backlight also illuminates for 30 seconds whenever an active Alarm / Warning message is displayed.	

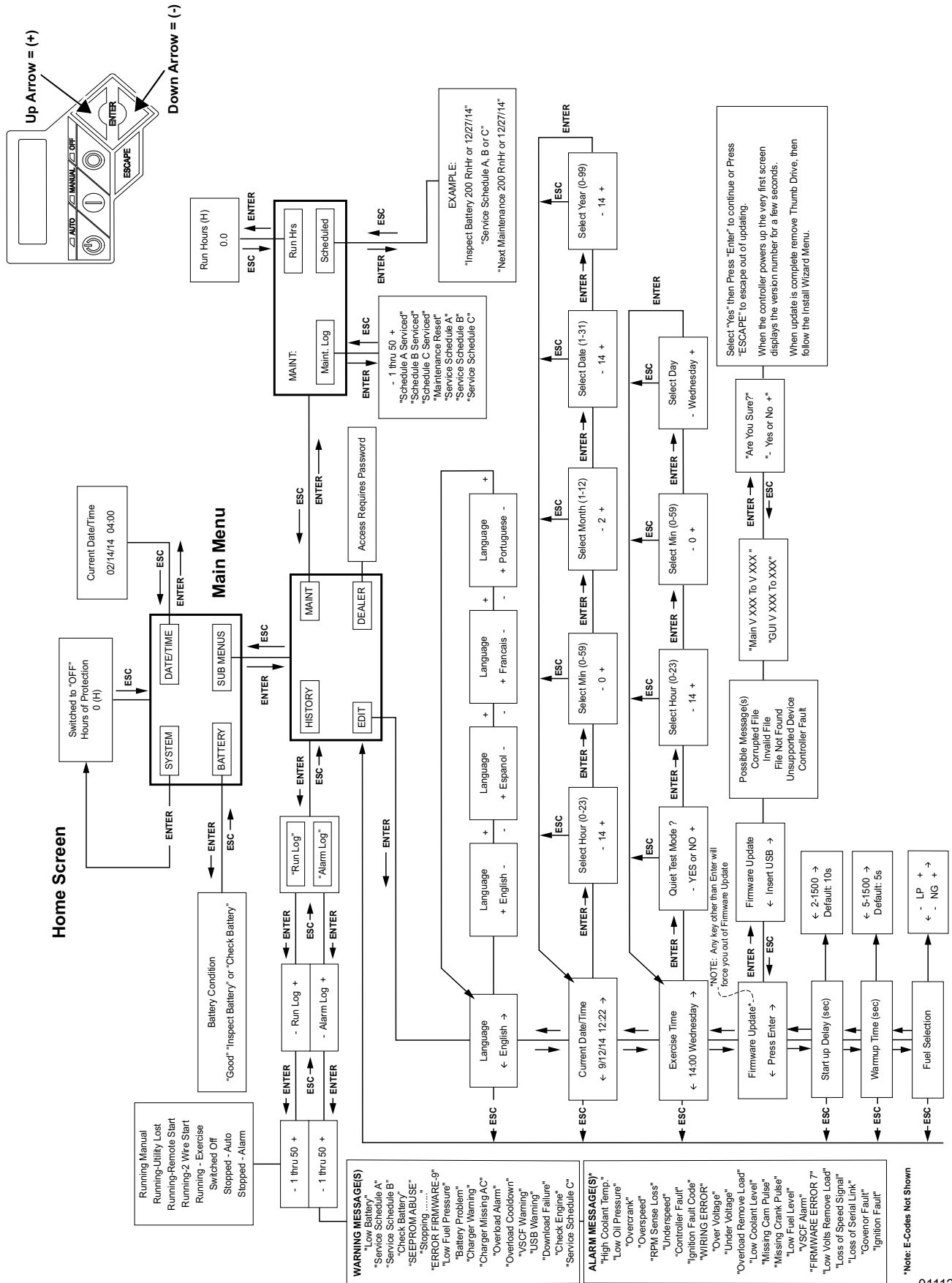

011127

Figure 4-2. Navigation Menu

Alarm / Warning Conditions

The owner / operator is alerted to Alarm and / or Warning conditions via the control panel LCD screen. All Alarm conditions cause generator to shut down.

Warning messages alert the operator to conditions that do not disable unit or require immediate correction.

Possible Alarm / Warning messages are listed below.

Alarm Messages		Warning Messages	
<ul style="list-style-type: none"> •High Engine Temperature •Low Oil Pressure •Overcrank •Overspeed •RPM Sense Loss •Underspeed •Controller Fault •Ignition Fault Code •Auxiliary Shutdown 	<ul style="list-style-type: none"> •WIRING ERROR •Over Voltage •Under Voltage •Overload •Canbus Error •Missing Cam Pulse •Missing Crank Pulse •Low Fuel Pressure •E-Stop 	<ul style="list-style-type: none"> •Low Battery •Exercise Set Error •Schedule A Maintenance •Schedule B Maintenance •Schedule C Maintenance •Battery Problem 	<ul style="list-style-type: none"> •Charger Warning •Charger Missing AC •USB Warning •Download Failure •Check Engine

NOTE: Unless properly trained to correct and clear Alarm / Warning conditions, contact an IASD.

NOTE: The factory default setting is five seconds, but is adjustable from 2 to 1,500 seconds.

Change Time and Date

To change time and date after activation, see Navigation Menu in [Figure 4-3](#). If power is lost (battery is disconnected / reconnected, control panel fuse is removed / installed, etc.), the display automatically prompts the user for Time and Date. All other information is retained in memory.

Warm-Up Delay Timer

A programmable Warm-Up Delay timer is provided. As soon as the generator starts, the warm-up timer is started. When the warm-up timer expires, the control transfers load to the generator (through the transfer switch) if the utility voltage is less than 80% of nominal. If utility voltage is greater than the threshold at expiration of the warm-up time, the load is **not** transferred to the generator and a cool-down period begins. At the end of the cool-down period, the generator stops.

NOTE: The factory default setting is five seconds, but is adjustable from 5 to 1,500 seconds.

Programmable Timers

Dealer Programmable

Exercise Time

A programmable exercise time is provided. In AUTO mode, the engine starts and runs once each week at the time and day specified. During exercise cycle, unit runs approximately 12 minutes and then shuts down. Transfer of loads to generator does not occur unless utility power fails.

NOTE: A Dealer password is required to change duration of Exercise Cycle.

USB Port for Firmware Updates

A USB port is located beneath the rubber flap on the control panel and is provided for firmware updates. Firmware updates must be performed by an Independent Authorized Service Dealer.

NOTE: The USB port is intended for use with a USB thumb drive only. The USB port is not intended for charging devices such as phones or laptops. Do not connect any consumer electronics to the USB port. Contact an IASD for any firmware updates.

User Programmable

Start-Up Delay Timer

A programmable line interrupt delay (or Start-Up Delay) timer is provided. When utility voltage fails (falls below 60% of nominal), start-up delay timer is started. If voltage rises above Utility Volts Low threshold, timer is reset. If utility voltage remains below threshold during the duration of timer, the unit cranks and starts.

Battery Charger

NOTE: The battery charger is integrated into the control panel module.

The battery charger ensures:

- Output is continually optimized to promote maximum battery life.
- Charging levels are safe.

NOTE: A warning message is displayed on the LCD screen when battery requires service.

Transfer Switch Automatic Operation

In AUTO, the generator starts automatically when utility source voltage drops below preset level. Once unit starts, loads are transferred to standby power source.

To select automatic operation:

1. Verify transfer switch main contacts are set to UTILITY position (loads connected to utility power source).
2. Verify normal UTILITY power source voltage is available to transfer switch terminal lugs N1, N2, and N3 (if three phase).
3. Move Main Circuit Breaker switch on control panel up to ON (Closed) position.
4. Press AUTO on control panel. A green LED will illuminate to confirm system is in AUTO mode.

Automatic Sequence of Operation

Utility Failure

If control panel is set to AUTO when utility power fails, a ten second Start-Up Delay timer is started (user programmable). If utility power is still absent when time expires, the engine will crank and start.

Once started, a **five** second engine Warm-Up Delay timer starts (user programmable). When time has elapsed, the load is transferred to the generator. If utility power is restored (above 90% of nominal, dealer programmable) between the time the engine is first started and expiration of the warm-up time, the controller completes the start cycle and then runs through its normal cool-down cycle (while the load remains on the utility source throughout the episode).

Cranking

The cyclic cranking is controlled as follows:

Fifteen (15) seconds crank, seven (7) seconds rest, seven (7) seconds crank, seven (7) seconds rest; this sequence is repeated for a total of six (6) crank cycles.

Load Transfer

With the generator running, the transfer of load is dependent upon the operating mode as follows:

AUTO	<ul style="list-style-type: none"> • Starts and runs if utility power fails (falls below 60% of nominal) for five consecutive seconds (adjustable). • Starts a five second (adjustable) engine warm-up timer. • Does not execute transfer if utility power returns before expiration of warm-up timer (but finishes the warm-up and cool-down cycles). • Transfers back to utility once utility power returns (above 80% of nominal) for fifteen consecutive seconds. • Only shuts down if OFF is pressed or an alarm shutdown occurs. • Once utility power returns, starts a cool-down cycle before it shuts down. <p>NOTE: Cool-down cycle is five minutes if turbocharger equipped, one minute if naturally aspirated.</p>
	EXERCISE
	<ul style="list-style-type: none"> • Only works in AUTO mode. • Does not exercise if generator is already running in AUTO. • During exercise cycle, transfers only if utility power fails for ten consecutive seconds.
MANUAL	<ul style="list-style-type: none"> • Engine cranks and runs even if utility power is present, but does not transfer to generator. • Transfers to generator if utility fails (falls below 60% of nominal) for ten consecutive seconds. • Transfers back to utility when utility returns for fifteen consecutive seconds. The engine continues to run until the AUTO or OFF key is pressed.

Transfer Switch Manual Operation



⚠ DANGER

Electrocution. Do not manually transfer under load. Disconnect transfer switch from all power sources prior to manual transfer. Failure to do so will result in death or serious injury, and equipment damage. (000132)

Prior to automatic operation, manually exercise the transfer switch to verify there is no binding or interference with proper operation of the mechanism. Manual operation of the transfer switch is required if automatic operation fails.

IMPORTANT NOTE: Always use the applicable transfer switch owner's manual for actual manual transfer switch operation instructions. The information presented here describes a transfer switch, which is not used for three phase applications. See specific manual for three phase transfer switch.

Transfer to Generator Power

When utility power fails, manually transfer to standby power and start the generator as follows:

1. Press OFF on control panel. A red LED will illuminate to confirm system is in OFF mode.
2. Move Main Circuit Breaker switch down to OFF (Open) position.
3. Turn off utility power supply to transfer switch using means provided (such as a utility main line circuit breaker).
4. Use manual transfer handle (A) inside transfer switch to move main contacts to STANDBY position (loads connected to standby power source) (C).
5. Press MANUAL on control panel. The engine will crank and start.
6. Allow engine to run for two minutes to bring it up to normal operating temperature.
7. Move Main Circuit Breaker switch up to ON (Closed) position.

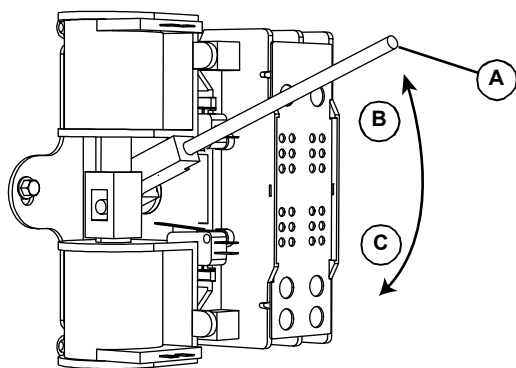

006375

Figure 4-3. Manual Transfer Switch Operation (Typical)

NOTE: V-style transfer switch not used for three phase applications.

Transfer Back to Utility Power

When utility power is restored, manually transfer back to utility power and shut down generator as follows:

NOTE: Verify utility voltage has returned and is at proper value.

1. Move Main Circuit Breaker switch down to OFF (Open) position.
2. Allow engine to run for two minutes at no-load to bring it up to normal operating temperature.
3. Press OFF on control panel to shut down engine.
4. Verify utility power supply to transfer switch is turned off.
5. Use manual transfer handle inside transfer switch to move main contacts to UTILITY position (loads connected to utility power source) (B).
6. Turn on utility power supply to transfer switch using means provided.
7. Press AUTO on control panel. A green LED will illuminate to confirm system is in AUTO mode.

This page intentionally left blank.

Section 5: Maintenance

Component Locations

The side of the enclosure with the viewing window is identified as the rear of the generator set. The right and left sides are identified by standing at the rear and looking towards the front of the unit.

NOTE: The 2.4L (32 kW) unit is depicted in the artwork used in this manual. The location and appearance of some components may vary between engine models.

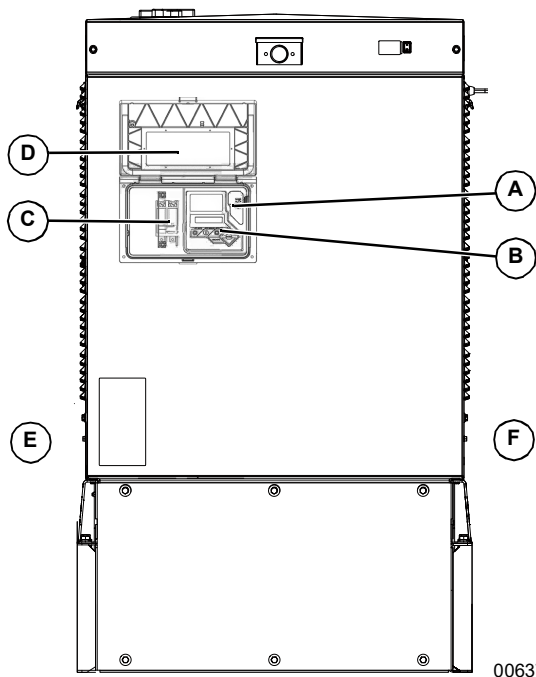

Item	Item Description
A	7.5 Amp Fuse and USB Port
B	Control Panel and LCD Screen
C	Main Circuit Breaker
D	Viewing Window
E	Left Side
F	Right Side

006378
Figure 5-1. Rear View

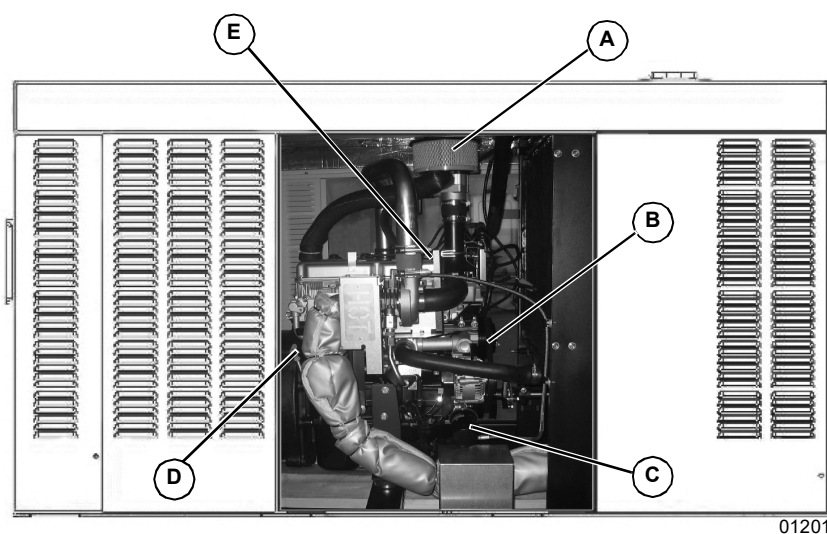

Item	Item Description
A	Air Filter Element
B	Timing Belt
C	Oil Filter
D	Oil Level Dipstick
E	Oil Fill Cap

012011
Figure 5-2. Right Side View

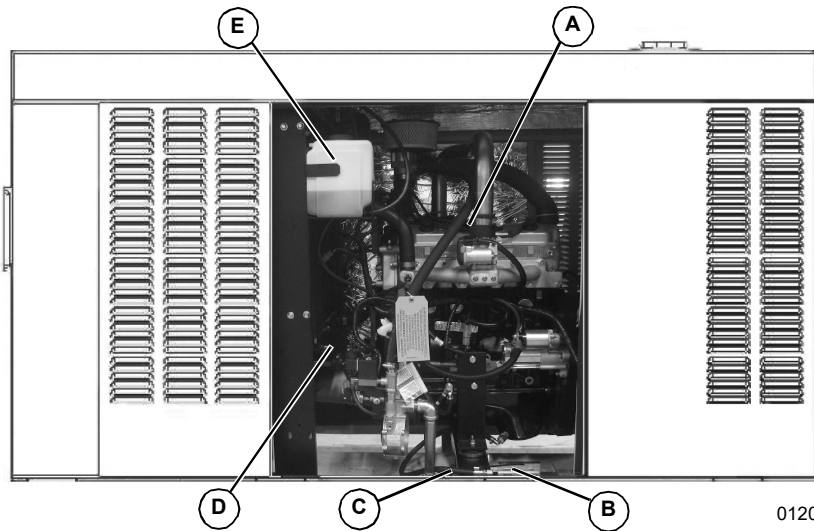

Item	Item Description
A	Spark Plugs
B	Battery
C	Oil Drain Hose
D	Coolant Drain
E	Coolant Overflow Reservoir

012019

Figure 5-3. Left Side View

NOTE: All normal maintenance and service items are easily accessible for consumer convenience. Wherever possible, touch points are colored orange to provide for quick and easy recognition.

Access Panels

Access panels are located at both the left and right sides of enclosure.

Removal

1. Insert key (B) into latch and rotate counterclockwise 1/2 turn. See [Figure 5-4](#).
2. Raise panel using thumb latch (A).

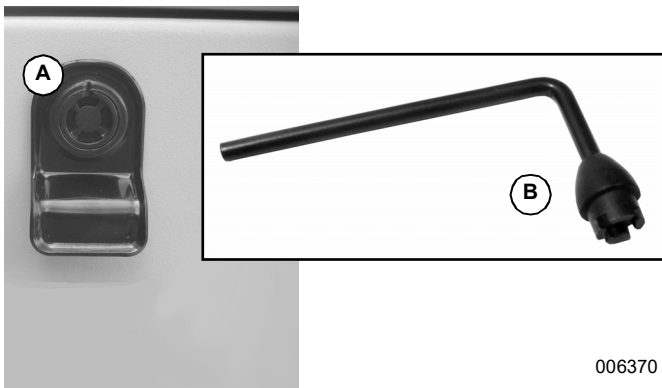

006370

Figure 5-4. Access Panel Key and Latch (Typical)

Installation

1. Lower panel into position using thumb latch.
2. Insert key into latch and rotate clockwise one-half turn.

Maintenance

Regular maintenance will improve performance and extend engine/equipment life. Generac Power Systems, Inc. recommends that all maintenance work be performed by an Independent Authorized Service Dealer (IASD). Regular maintenance, replacement, or repair of the emissions control devices and systems may be performed by any repair shop or person of the owner's choosing. To obtain emissions control warranty service free of charge, the work must be performed by an IASD. See the emissions warranty.

WARNING

Equipment damage. Only qualified service personnel may install, operate, and maintain this equipment. Failure to follow proper installation requirements could result in death, serious injury, and equipment or property damage. (000182a)

It is important to perform all maintenance at the interval specified in the [Service Maintenance Schedule](#). This ensures safe and proper operation, as well as compliance with applicable emissions standards.

Service Maintenance Schedule

Observe the maintenance tasks and intervals shown in the table below.

Service	30 Hours Engine Break In	Daily If Running Continuously	Schedule A Every Year or 125 Hours	Schedule B Every 2 Years or 250 Hours	Schedule C Every 1000 Hours
Check Enclosure Louvers		•	•	•	•
Check Fuel Lines		•	•	•	•
Check Coolant Level and Hoses		•	•	•	•
Check Radiator for Clogging		•	•	•	•
Check Lubricating Oil Level and Drain Hose		•	•	•	•
Replace Lubricating Oil and Oil Filter	•		•	•	•
Replace Battery Every Three Years*					
Check/Adjust Accessory/Drive Belt Tension			•	•	•
Replace Air Filter Element			•	•	•
Drain/Flush Coolant System				•	•
Replace Spark Plugs				•	•
Replace Timing Belt (2.4L Engines Only)					•
Tighten Critical Fasteners					•

* Replace battery every two years in extreme conditions.

NOTE: If the unit reaches a Schedule A or Schedule B maintenance interval with 900 to 999 total hours, have an Independent Authorized Service Dealer perform the Schedule C maintenance tasks as well (and reset the A-B-C/Year maintenance schedule counter).

Remove From Service

To ensure safety, follow the steps below prior to inspection, maintenance or service.

IMPORTANT NOTE: If currently experiencing a utility outage, see [Removal From Service During Utility Outages](#) for special instructions.

1. Open viewing window. See [Open Viewing Window](#).
2. See [Figure 5-5](#). Move Main Circuit Breaker switch down to OFF (Open) position (A).
3. Verify both auxiliary shutdown switches are OFF (O).
4. Press OFF on control panel (B). A red LED will illuminate to confirm system is in OFF mode.
5. Remove T1 fuse from transfer switch.
6. Pull up rubber flap (C) covering fuse holder and remove 7.5 amp fuse.

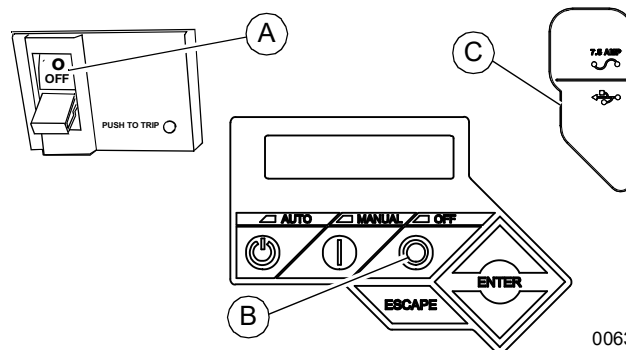

Figure 5-5. Generator Control Panel

WARNING

Accidental Start-up. Disconnect the negative battery cable, then the positive battery cable when working on unit. Failure to do so could result in death or serious injury. (000130)

7. Disconnect NEGATIVE battery cable.
8. Place a DO NOT OPERATE tag or placard on both control panel and transfer switch.
9. If unit has been running, wait five minutes for engine to cool.

30 Hour Break-In

Perform the following task:

- Replace Lubricating Oil and Oil Filter

NOTE: See [Replace Lubricating Oil and Oil Filter](#) under Schedule A Maintenance.

Daily Maintenance

Perform the following tasks:

- Check Enclosure Louvers
- Check Fuel Lines
- Check Coolant Level and Hoses
- Check Radiator for Clogging
- Check Lubricating Oil Level and Drain Hose

NOTE: See [Check Enclosure Louvers](#) through [Check Coolant Level and Hoses](#) under Schedule A Maintenance.

Schedule A Maintenance

NOTE: Perform Schedule A maintenance once each year or after 125 hours of service, whichever comes first.

The 2.4L (32 kW) unit is depicted in the artwork used in this manual. For the general location of components in all other models, see [Figure 5-9](#).

Schedule A Maintenance Item Locations

NOTE: The side of the enclosure with the viewing window is identified as the rear of the generator set. The right and left sides are identified by standing at the rear and looking towards the front of the unit.

Model	22/27 kW	25/30 kW	32/38 kW	36/45 kW	60 kW
Engine	2.4L	1.5L	2.4L	2.4L	2.4L
Coolant Overflow Reservoir	L	L	L	L	L
Oil Dipstick	R	R	R	R	R
Oil Drain Hose	L	R	L	L	L
Oil Filter	R	R	R	R	R
Oil Fill Cap	E	E	E	E	E
Oil Supply Tank Fill Cap	-	-	-	TL	TL
Battery	L	R	L	L	L
Fan Belt	E	E	E	E	E
Air Filter Element	L	R	L	L	L
R = Right Side L = Left Side E = Either Side T = Top - = Not Applicable					

Preliminary Instructions

1. See [Remove From Service](#).
2. Remove left and right side access panels. See [Access Panels](#).
3. Remove negative battery cable (black) from negative (-) battery terminal.

Check Enclosure Louvers

1. Verify intake and exhaust louvers and openings are clean and unobstructed. Keep leaves, grass, snow, and debris clear of openings.
2. Wipe exterior surfaces clean using a damp cloth.
3. Loosen dirt, oil, etc. with a soft bristle brush.

Check Coolant Level and Hoses

4. Remove loose dirt and debris using a vacuum cleaner, or low pressure compressed air (not exceeding 25 psi (172 kPa)).

NOTE: Periodically wash and wax enclosure using automotive type products. Frequent washing is recommended in salt water / coastal areas.

Check Fuel Lines

1. Check fuel lines for leaks. Tighten fittings and clamps if necessary.
2. Check fuel lines for nicks, dents, kinks, or other damage. Replace as necessary.

WARNING

Risk of burns. Allow engine to cool before draining oil or coolant. Failure to do so could result in death or serious injury.

(000139)

1. See [Figure 5-6](#). Verify coolant level is between HOT and COLD marks on overflow reservoir.



012040

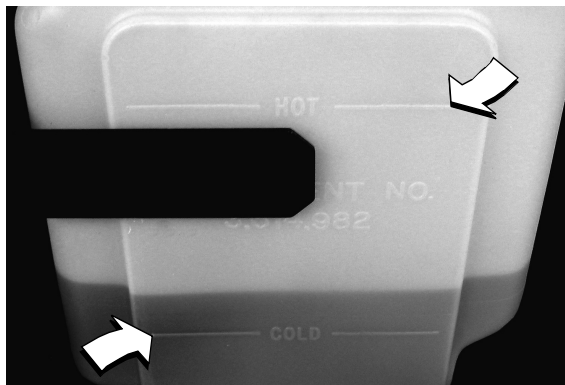

012041

Figure 5-6. Coolant Overflow Reservoir

Check Radiator for Clogging

1. Use a flashlight to inspect radiator fins.
2. Look for debris, accumulations of dirt, or other deposits.
3. Carefully remove any debris from radiator fins. Use warm soapy water and a soft bristled brush to remove dirt and other deposits, if necessary.

Check Lubricating Oil Level and Drain Hose

NOTE: If changing engine lubricating oil and filter, see [Replace Lubricating Oil and Oil Filter](#).

1. If engine was running, allow at least 10 minutes to elapse to ensure oil has fully drained into oil pan.

NOTE: The most accurate oil level readings are obtained when engine is cold.

2. See [Figure 5-7](#). Remove dipstick (B) and wipe dry with a clean, lint free cloth.
3. Slowly insert dipstick into dipstick tube.
4. Verify dipstick is fully seated in dipstick tube.

NOTE: Some dipsticks require more effort to fully seat than others.

5. Allow at least 10 seconds to elapse.
6. Slowly remove dipstick.
7. Verify oil level is at or near FULL mark (A). Add oil as necessary (C).

NOTE: Coolant expands when hot, so level may be higher than HOT mark. Do not add coolant higher than HOT mark.

2. If coolant level is below COLD mark, remove fill cap from overflow reservoir and add coolant. See [Coolant Water Treatment](#).
3. Check coolant hoses for leaks. Tighten hose clamps, if necessary.
4. Check hoses for nicks, cuts, tears or general deterioration. Replace as necessary.

NOTE: Observe oil level on both sides of dipstick. The lower of the two readings is the correct oil level measurement.

8. If necessary, remove oil fill cap and slowly add oil. **Do not fill above "FULL" mark on dipstick.**
9. Install dipstick and oil fill cap.
10. Install battery negative cable (black) onto battery negative (-) terminal.
11. Pull up rubber flap covering fuse holder and install 7.5 amp fuse.
12. Press MANUAL on control panel to start engine.
13. Allow engine to run for one minute.
14. Press OFF on control panel to shut down engine. A red LED will illuminate to confirm system is in OFF mode.
15. Return to step 1.

NOTE: The most common reasons for inaccurate oil level readings are:

- **Reading dipstick before the oil has fully drained into oil pan.**
- **Inserting and removing dipstick too quickly.**
- **Reading dipstick when it has not been fully seated in dipstick tube.**
- **Reading only high level side of dipstick.**

16. Check oil drain hose for leaks. Check hose for nicks, cuts, tears or general deterioration. Replace as necessary.

17. Pull up rubber flap covering fuse holder and remove 7.5 amp fuse.
18. Remove battery negative cable (black) from battery negative (-) terminal.

NOTE: On 36 kW, 45 kW, and 60 kW models, check level of oil in the clean oil supply tank. Add clean oil as necessary. For more information, see [Lube Oil Maintainer System](#).

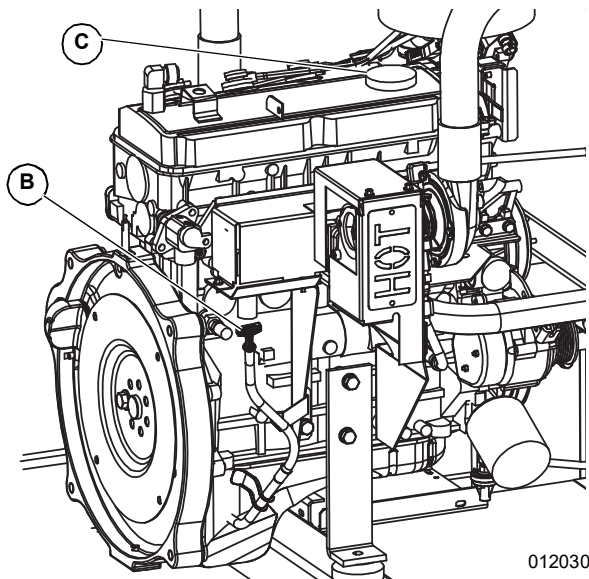
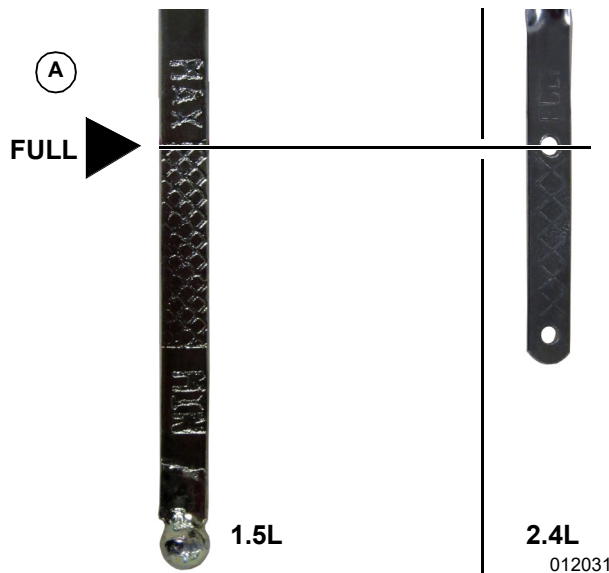

Figure 5-7. Oil Level Dipstick and Oil Fill Cap

Replace Lubricating Oil and Oil Filter

NOTE: On 36 kW, 45 kW, and 60 kW models, close shutoff valve to avoid draining the oil supply tank with crankcase oil. For more information, see [Lube Oil Maintainer System](#).

1. See [Figure 5-8](#). Remove oil drain hose from holding clamp (A).
2. Use one wrench to hold hex on hose fitting (to prevent rotation), and use second wrench to remove drain plug.



WARNING

Risk of burns. Allow engine to cool before draining oil or coolant. Failure to do so could result in death or serious injury.

(000139)

WARNING

Skin irritation. Avoid prolonged or repeated contact with used motor oil. Used motor oil has been shown to cause skin cancer in laboratory animals. Thoroughly wash exposed areas with soap and water.

(000210)

3. Drain oil into a suitable container.
4. Install drain plug onto end of oil drain hose.
5. Install oil drain hose into holding clamp.
6. See [Figure 5-8](#). Rotate oil filter counterclockwise to remove from oil filter adapter (B).
7. Apply a light coat of clean engine oil to gasket of **new** oil filter.
8. Install oil filter by hand until gasket just contacts oil filter adapter. Tighten oil filter an additional 3/4 to one full turn.
9. Remove fill cap and fill engine with recommended quantity and type of oil. See [Engine Oil Recommendations](#). Crankcase oil capacity is listed below:

Lubrication System Capacity (Oil Pan Including Oil Filter)					
Model	22 / 27 kW	25 – 30 kW	32 / 38 kW	36 / 45 kW	60 kW
Engine	2.4L	1.5L	2.4L	2.4L	2.4L
4.0 quarts (3.8 liters)	•	•	•	•	
5.25 quarts (5 liters)					•

10. Install fill cap.

11. Install negative battery cable (black) onto negative (-) battery terminal.
12. Pull up rubber flap covering fuse holder and install 7.5 amp fuse.
13. Press MANUAL on control panel to start engine.
14. Allow engine to run for one minute. Check for leaks while engine is running.
15. Press OFF on control panel. A red LED will illuminate to confirm system is in OFF mode.
16. Wait ten minutes for engine to cool and to allow oil to drain back to oil pan.
17. Check oil level and add oil as necessary. See [Check Lubricating Oil Level and Drain Hose](#).
18. Install fill cap.

NOTE: On 36 kW, 45 kW, and 60 kW models, open shutoff valve to enable Lube Oil Maintainer System.

NOTE: Dispose of used oil and oil filter at a proper collection center.

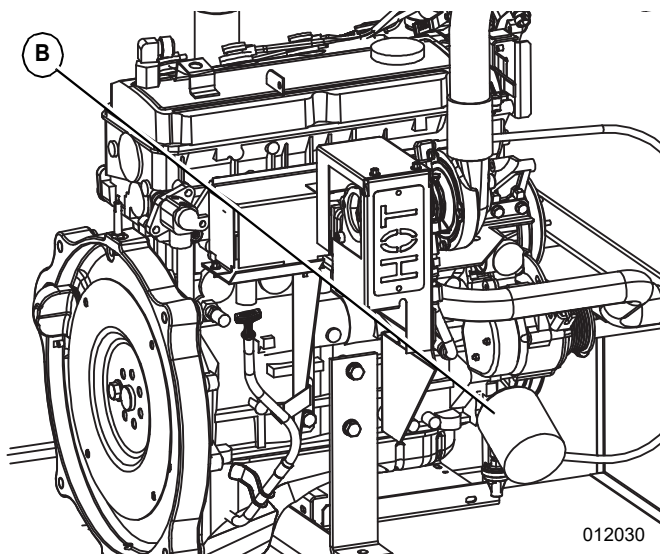
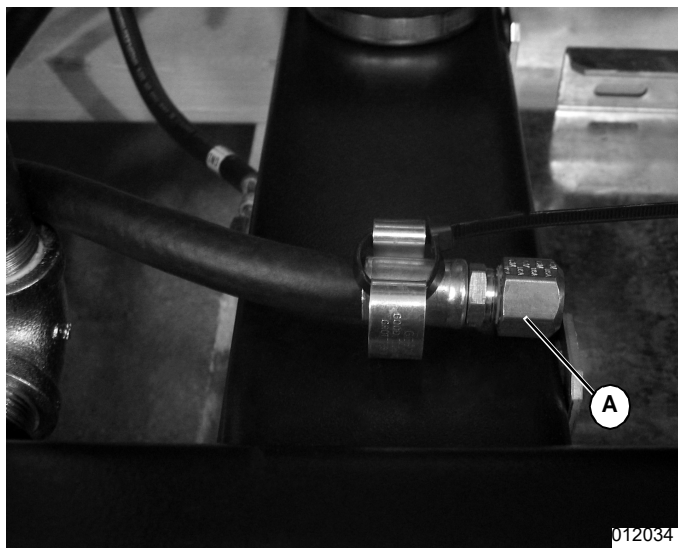

Figure 5-8. Oil Drain Hose, Fill Cap, Dipstick, and Filter

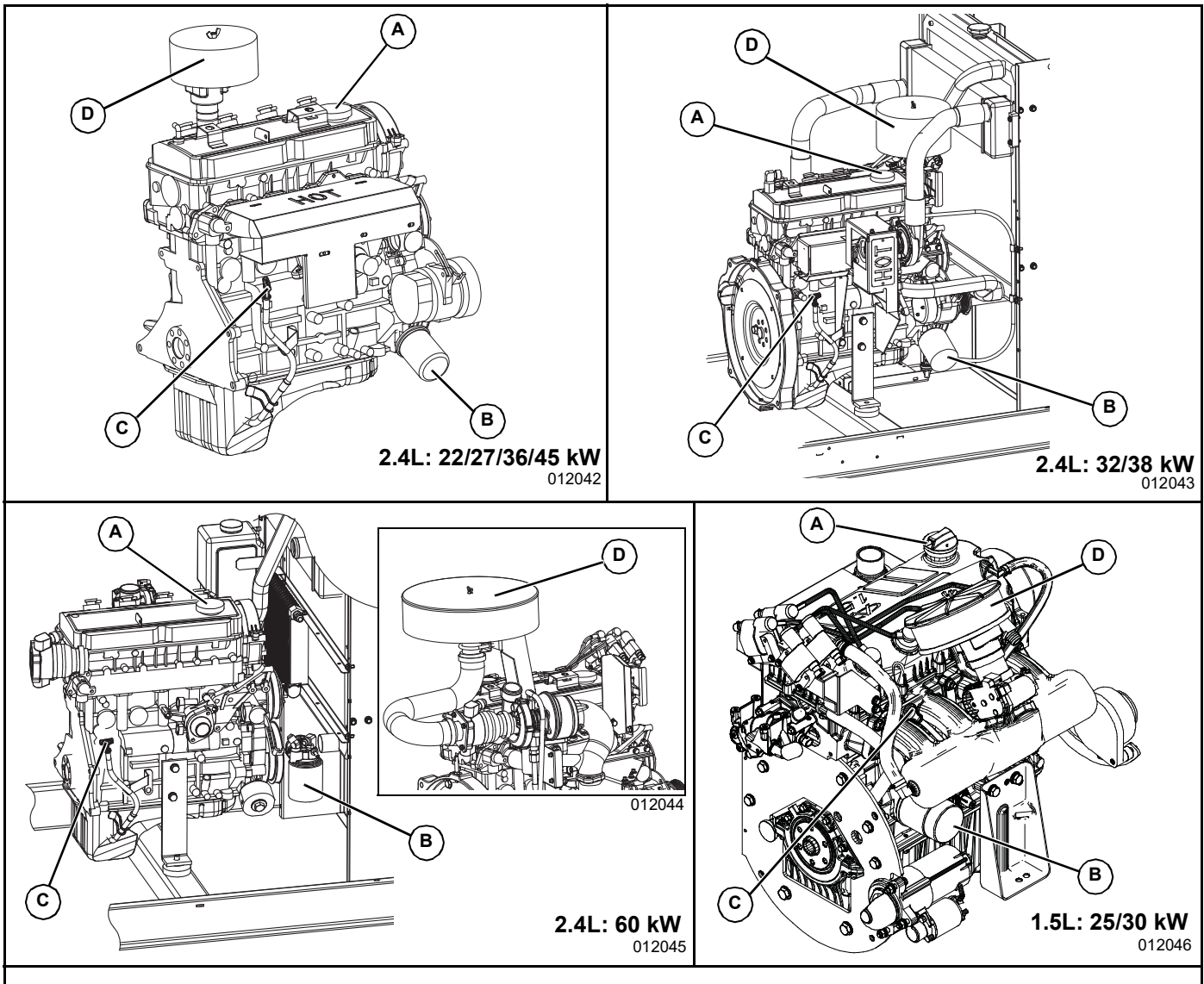

Figure 5-9. Engine Oil and Air Cleaner Maintenance (All Models)

Item	Item Description
A	Oil Fill Cap
B	Oil Filter
C	Oil Level Dipstick
D	Air Cleaner

Check Battery Condition

Check Condition and Clean

- See [Figure 3-3](#) for illustration. Verify top of battery is clean and dry. Dirt and electrolyte on top of the battery can cause battery to self-discharge. Clean battery top with a solution of baking soda (sodium bicarbonate) and water (5 teaspoons baking soda per quart or liter of water). When solution stops bubbling, rinse off battery with clean water.
- Clean cable clamps and battery terminals using a wire brush or sandpaper to remove any oxidation.
- Inspect battery screws, clamps and cables for breakage, loose connections and corrosion. Tighten and clean as necessary.
- Check battery posts for melting or damage caused by over tightening.
- Inspect battery for discoloration, raised top or a warped or distorted case, which might indicate battery has been frozen, overheated, or overcharged.
- Inspect battery case for cracks or leaks.

7. Check battery state of charge. See [Check State of Charge](#).
8. Replace battery if necessary. See [Battery Replacement](#).

Check State of Charge

Check the state of charge using a Digital Multimeter. Recharge and retest if state of charge is below manufacturer's recommendations. Replace battery if necessary.

Battery Replacement

Removal



⚠ WARNING

Electrical shock. Disconnect battery ground terminal before working on battery or battery wires. Failure to do so could result in death or serious injury.

(000164)

⚠ WARNING

Accidental Start-up. Disconnect the negative battery cable, then the positive battery cable when working on unit. Failure to do so could result in death or serious injury.

(000130)

1. Remove negative battery cable (black) (B) from negative (-) battery terminal.
2. Remove positive battery cable (red) (A) from positive (+) battery terminal.
3. See [Figure 5-10](#). Install rubber protective cover over positive (+) battery terminal (A).
4. Loosen two screws with nylon washers to release battery hold-down clamp from battery tray.
5. Grasp battery strap (B), and lift battery from battery tray.
6. Remove rubber protective cover from positive (+) battery terminal.

Installation

⚠ WARNING

Accidental Start-up. Disconnect the negative battery cable, then the positive battery cable when working on unit. Failure to do so could result in death or serious injury.

(000130)

1. Install rubber protective cover over positive (+) battery terminal (A).
2. Grasp battery strap (B) and lift battery.
3. Set battery onto battery tray.
4. Tighten two screws with nylon washers to secure hold-down clamp to battery tray.

5. Remove rubber protective (A) cover from positive (+) battery terminal.
6. Install positive battery cable (red) to positive (+) battery terminal.
7. Install negative battery cable (black) to negative (-) battery terminal.

NOTE: If continuing with Schedule A maintenance procedures, leave the battery negative cable (black) disconnected.

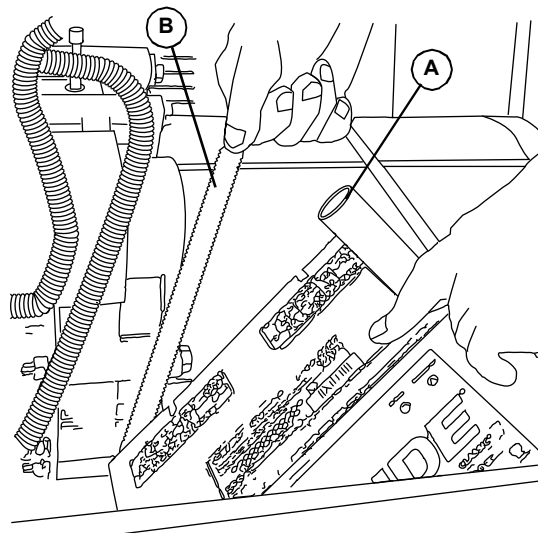

001499

Figure 5-10. Remove / Install Battery

Check and Adjust Accessory / Drive Belt

Check

Check the accessory / drive belt condition.

1. Perform visual inspection as follows:
 - Inspect belt for cracks, fraying, excessive wear or other damage.
 - Verify belt is free of grease and oil.
 - Replace belt if contaminated, damaged, frayed or worn.

NOTE: Use a solution of soap and warm water to clean pulleys, if necessary. Avoid the use of solvents, but if used, always follow by a soap and water wash.

2. Check fan belt deflection. Adjust belt deflection as follows:
 - See [Figure 5-11](#). Using a suitable gauge, apply 22 lbs (10 kgf) force midway between water pump and alternator pulleys.
 - Take note of gauge reading. If belt deflection is not within specification, see [Adjust](#).

Belt Deflection	English	Metric
	3/8 - 5/8 in	7.6 - 12.7 mm

Adjust

1. Loosen DC alternator tension bracket screw. Rotate alternator (C) outward to reduce belt deflection.
2. Rotate inward to increase belt deflection.
3. Tighten DC alternator tension bracket screw to 17-22 ft-lbs (23-30 Nm).
4. Recheck belt deflection and repeat steps as necessary.

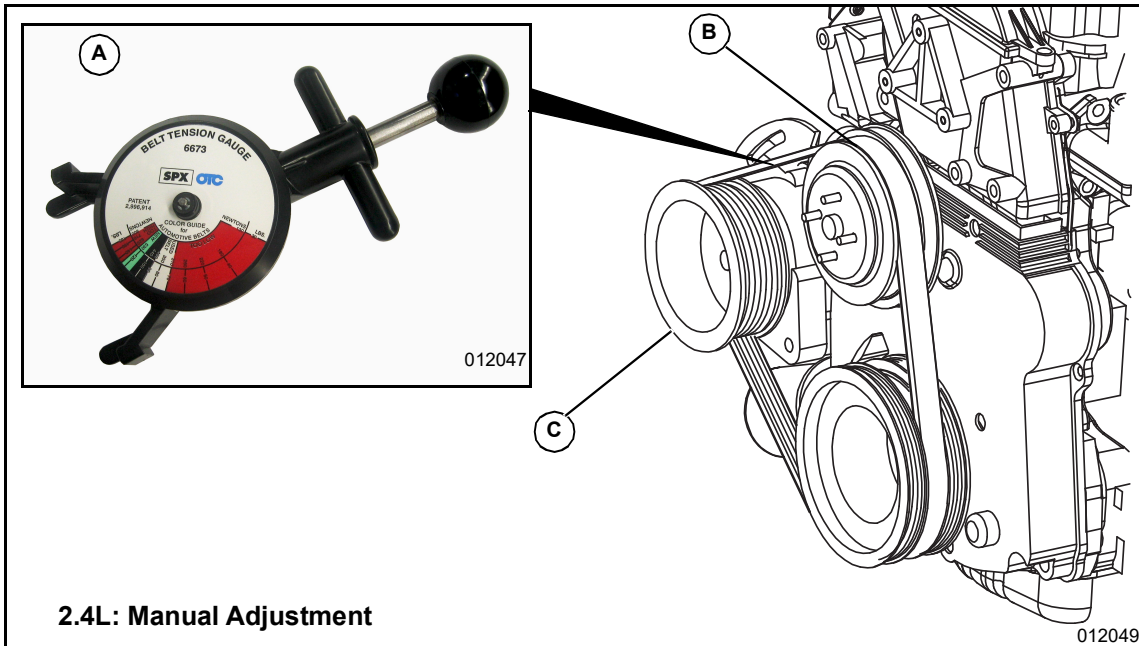

2.4L: Manual Adjustment

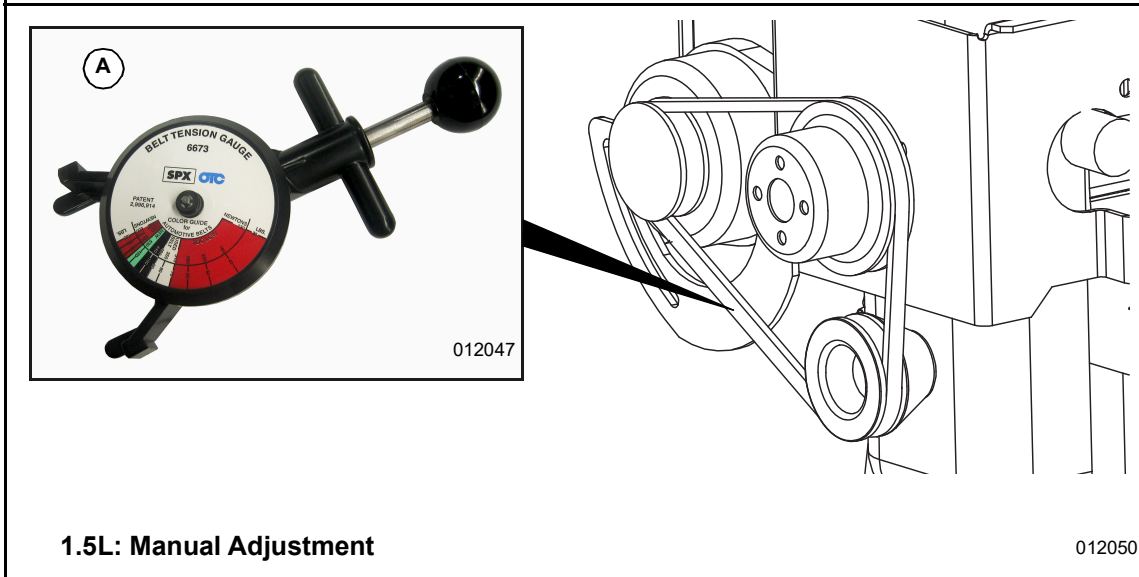

1.5L: Manual Adjustment

Figure 5-11. Check Accessory / Drive Belt Deflection

Item	Item Description
A	Belt Deflection Gauge
B	Water Pump Pulley
C	Alternator Pulley

Replace Air Filter Element

1. See [Figure 5-12](#). Remove wing nut (B), lock washer (C), and flat washer (D) from threaded rod to release air cleaner cover.
2. Remove air filter element (A) and discard.
3. Thoroughly clean air cleaner cover of any dust, dirt, or debris.

4. Place **new** air filter element against adapter flange.

NOTE: The air filter element is not directional.

5. Install air cleaner cover (E) over threaded rod. Install flat washer, lock washer and wing nut. Tighten wing nut until snug.

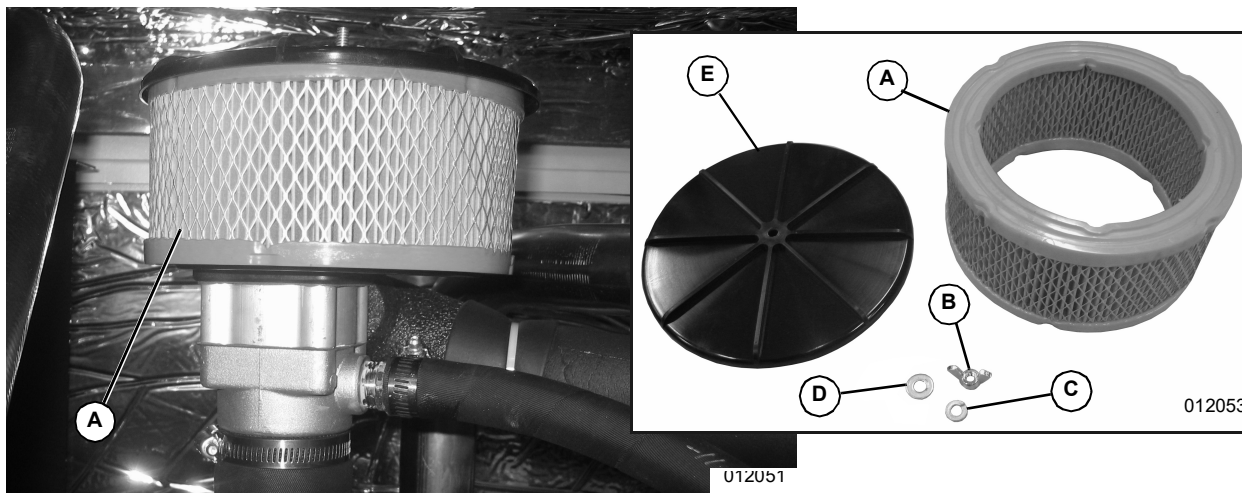

Figure 5-12. Air Cleaner Cover and Filter Element

NOTE: Service kits are available from Independent Authorized Service Dealers.

Final Instructions

If only performing Schedule A maintenance procedures, proceed as follows:

1. Install battery negative cable (black) onto battery negative (-) terminal.
2. Install left and right side access panels. See [Access Panels](#).
3. See [Return To Service](#).

Schedule B Maintenance

NOTE: Perform Schedule B maintenance every two years or after 250 hours of service, whichever comes first. Before proceeding below, first perform all tasks listed under Schedule A Maintenance.

NOTE: The 2.4L (32 kW) unit is depicted in the artwork used in this manual. For the general location of components in all other models, see [Schedule B Maintenance Item Locations](#).

Schedule B Maintenance Item Locations

NOTE: The side of the enclosure with the viewing window is identified as the rear of the generator set. The right and left sides are identified by standing at the rear and looking towards the front of the unit.

Model	22 / 27 kW	25 / 30 kW	32 / 38 kW	36 / 45 kW	60 kW
Engine	2.4L	1.5L	2.4L	2.4L	2.4L
Coolant Drain Hose	L	R	L	L	L
Radiator Fill Cap	T	T	T	T	T
Coolant Overflow Reservoir	L	L	L	L	L
Spark Plugs	L	R	L	L	L
R = Right Side L = Left Side B = Both Sides T = Top					

Drain / Flush Coolant System

1. Disconnect and empty coolant overflow reservoir.
2. Install and connect coolant overflow reservoir.



WARNING

Risk of burns. Allow engine to cool before draining oil or coolant. Failure to do so could result in death or serious injury.

(000139)

3. Rotate and remove plastic cover at top of enclosure.
4. Slowly unscrew radiator cap.
5. Locate drain cock at bottom left side of radiator.

NOTE: If unit is not equipped with drain hose, install suitable length of rubber hose to drain cock.

6. See **Figure 5-13**. Rotate hex fitting to open drain cock (A).
7. Remove coolant drain hose from holding clamp.
8. Use wrench to hold hex on hose fitting (to prevent rotation), and use second wrench to remove drain plug.
9. Drain coolant into a suitable container.
10. Install plug at end of drain hose.
11. Install drain hose in holding clamp.
12. Rotate hex fitting to close radiator drain cock.
13. Obtain recommended quantity and type of coolant. See **Coolant Water Treatment**.

System Coolant Capacity					
Model	22 / 27 kW	25 / 30 kW	32 / 38 kW	36 / 45 kW	60 kW
Engine	2.4L	1.5L	2.4L	2.4L	2.4L
2.0 gallons (7.6 liters)		•			
2.5 gallons (9.5 liters)	•		•	•	•

14. Insert funnel into filler neck of radiator (B). See **Drain / Fill Coolant System**.
15. Slowly pour coolant into filler neck until radiator is full.
16. Install radiator cap.
17. Press MANUAL on control panel to start engine. A blue LED will illuminate to confirm system is in MANUAL mode.
18. Allow engine to run until thermostat opens, as indicated by heating of top radiator hose.
19. Check coolant hoses for leaks. Tighten clamps, if necessary.

20. Press OFF on control panel to shut engine down.
21. Wait for engine to cool.
22. Repeat steps 4 – 21 to drain and refill cooling system.
23. Slowly unscrew radiator cap. Slowly pour coolant into filler neck until radiator is full.
24. Add coolant to overflow reservoir. See **Check Coolant Level and Hoses**.
25. Install plastic cover at top of enclosure and rotate until tight.
26. Check hoses for nicks, cuts, tears or general deterioration. Replace as necessary.

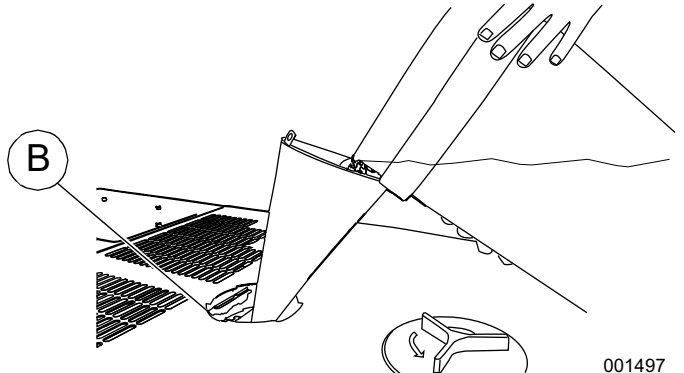
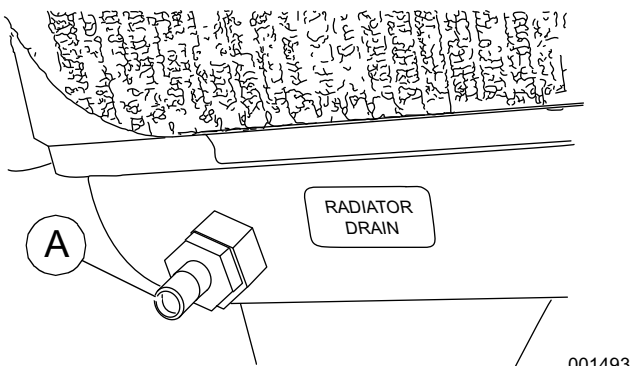

NOTE: Drain hose removed for illustration purposes.

Figure 5-13. Drain / Fill Coolant System

Clean / Gap / Replace Spark Plugs

Clean, gap, or replace spark plugs as follows:



WARNING

Electric shock. Do not disconnect spark plug wires with engine running. Doing so could result in death or serious injury.

(000140a)

1. Remove battery negative cable (black) from battery negative (-) terminal.
2. See [Figure 5-14](#). Remove spark plug cables from spark plug terminals (A).

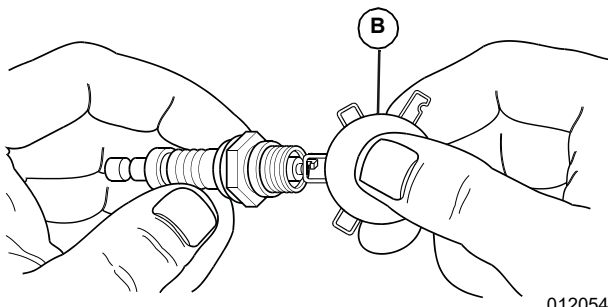

Figure 5-14. Adjust Spark Plug Gap

7. Check spark plug gap using a wire feeler gauge (B). Adjust gap by carefully bending ground electrode as follows:

Spark Plug Gap					
Model	22 / 27 kW	25 / 30 kW	32 / 38 kW	36 / 45 kW	60 kW
Engine	2.4L	1.5L	2.4L	2.4L	2.4L
0.71 mm (0.028 in.)			•		•
0.9 mm (0.035 in.)		•			
1.07-1.17 mm (0.042-0.046 in.)	•			•	

8. Finger tighten spark plugs into cylinder head.
9. Using a spark plug socket, tighten as follows:

Spark Plug Torque		
Engine	ft-lbs	N-m
1.5L, 2.4L	18	25

10. Install spark plug cables onto spark plug terminals.
11. Verify spark plug cables are captured in cable clips at top of valve cover.

NOTE: When disconnecting spark plug cable from spark plug terminal, always grasp and pull on the boot at the terminal end of the cable. Pulling on cable portion can result in parts damage.

3. Thoroughly clean area around spark plugs.
4. Remove spark plugs from cylinder head using an appropriate spark plug socket wrench.
5. Check condition of threads in cylinder head and on spark plugs. If necessary, soften deposits with penetrating oil and clean out with a thread chaser.
6. Clean spark plugs using a wire brush and commercial solvent. Do not blast spark plugs. Use **new** spark plugs if necessary.

Final Instructions

If only performing Schedule A and Schedule B maintenance procedures, proceed as follows:

1. Install battery negative cable (black) onto battery negative (-) terminal.
2. Install left and right side access panels. See [Access Panels](#).
3. See [Return To Service](#).

Schedule C Maintenance

NOTE: Perform Schedule C maintenance after 1,000 hours of service. Before proceeding below, first perform all tasks listed under Schedule A Maintenance and Schedule B Maintenance.

IMPORTANT NOTE: The following procedures require special tools and skills. Contact an Independent Authorized Service Dealer to perform these tasks.

1. Remove battery negative cable (black) from battery negative (-) terminal.
2. Proceed as follows:
 - Replace timing belt (2.4L engines only).
 - Tighten critical fasteners.
 - Replace upper and lower radiator hoses.
 - Replace engine coolant bypass hoses.
 - Replace block heater hoses.

NOTE: Reset the A-B-C/Year time maintenance schedule counter using the Dealer Sub Menu (password required).

3. Install battery negative cable (black) onto battery negative (-) terminal.
4. Install front access panel. Install left and right side access panels. See [Access Panels](#).
5. See [Return To Service](#).

Return To Service

After inspection, maintenance or service of the generator, return unit to service.

1. See [Figure 5-5](#). Pull up rubber flap covering fuse holder and install 7.5 amp fuse (A).
2. Install T1 fuse in transfer switch.
3. Verify both auxiliary shutdown switches are ON (I). See [Figure 3-6](#) for the locations.
4. Press AUTO on control panel. A green LED will illuminate to confirm system is in AUTO mode (B).
5. Move Main Circuit Breaker switch up to ON (Closed) position (C).
6. Close viewing window.
7. Remove DO NOT OPERATE tag or placard from both control panel and transfer switch.
8. Reset time and date.

Lube Oil Maintainer System

Description

NOTE: Oil reservoir is empty when shipped from factory. Fill with clean engine oil to activate system.

The 36 kW, 45 kW, and 60 kW models are equipped with a Lube Oil Maintainer System. The system is installed at the factory and calibrated at the factory to the correct engine-running crankcase oil level. As needed, the system keeps the engine lubricating oil full by automatically adding clean oil from the oil supply tank.

NOTE: The Lube Oil Maintainer System is equipped with three wires (red, white, black) which are not used in this unit.

See [Figure 5-15](#). The green bar (A) observed through the viewing lens (B) shows the normal oil level operating range of the Lube Oil Maintainer Regulator during engine running operation. When the oil level is within the green bar, the internal float holds the inlet valve closed to keep the crankcase oil at the current level.

As the engine uses oil, the float drops to open the inlet valve and allow clean oil to be supplied to the crankcase, replenishing engine oil to the full mark indicated on the oil dipstick. The float then rises with the crankcase oil level until it reaches a point where the inlet valve closes.

When the oil level as observed through the viewing lens is below the normal operating range green bar, it is an indication the oil supply tank is low or the oil inlet screen is clogged (C).

NOTE: It is normal for the oil level to be above the normal operating range green bar (D) when engine is not running.

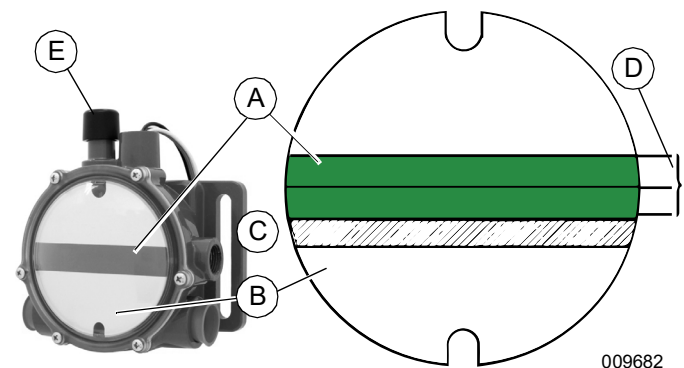
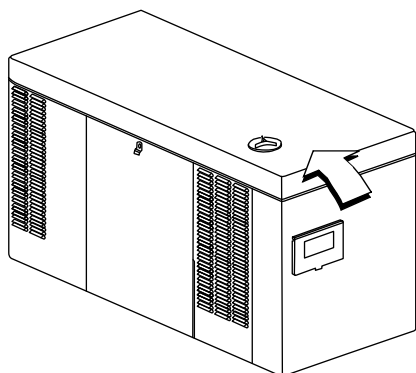

Figure 5-15. Lube Oil Maintainer Regulator

NOTE: See [Figure 5-9](#). When changing engine oil, always close the shutoff valve to avoid draining the clean oil in the oil supply tank with the crankcase oil.

Fill Oil Supply Tank

1. See [Figure 5-17](#). Rotate plastic cover counter-clockwise and remove from top of enclosure.
2. Remove fill cap at top of oil supply tank ([Figure 5-18](#)).
3. Add clean engine oil to oil supply tank (2-1/2 gallons [9.46 liters] capacity).
4. Install fill cap at top of oil supply tank.
5. Install plastic cover at top of enclosure and rotate clockwise until tight.



009678

Figure 5-16. Access Oil Supply Tank

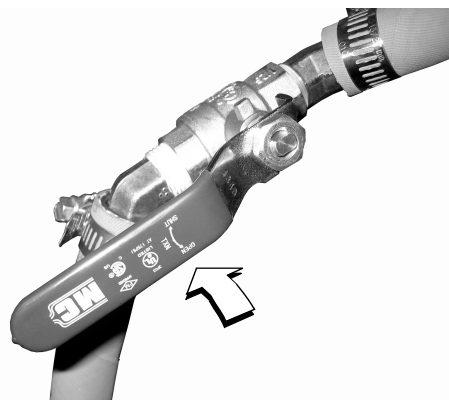

009681

Figure 5-17. Shutoff Valve (Shown in Open Position)

Test Functionality

See [Figure 5-15](#). Momentarily press test button (E) to confirm float is operating correctly.

NOTE: Do not hold the test button down for a prolonged period of time or the crankcase can be over filled. Over filling the crankcase can result in engine damage.

Shutoff Valve

See [Figure 5-17](#) and [Figure 5-18](#). When draining engine crankcase oil, always close shutoff valve to avoid draining clean oil from supply tank.

After filling crankcase with clean oil, remember to open shutoff valve to enable operation of Lube Oil Maintainer System.

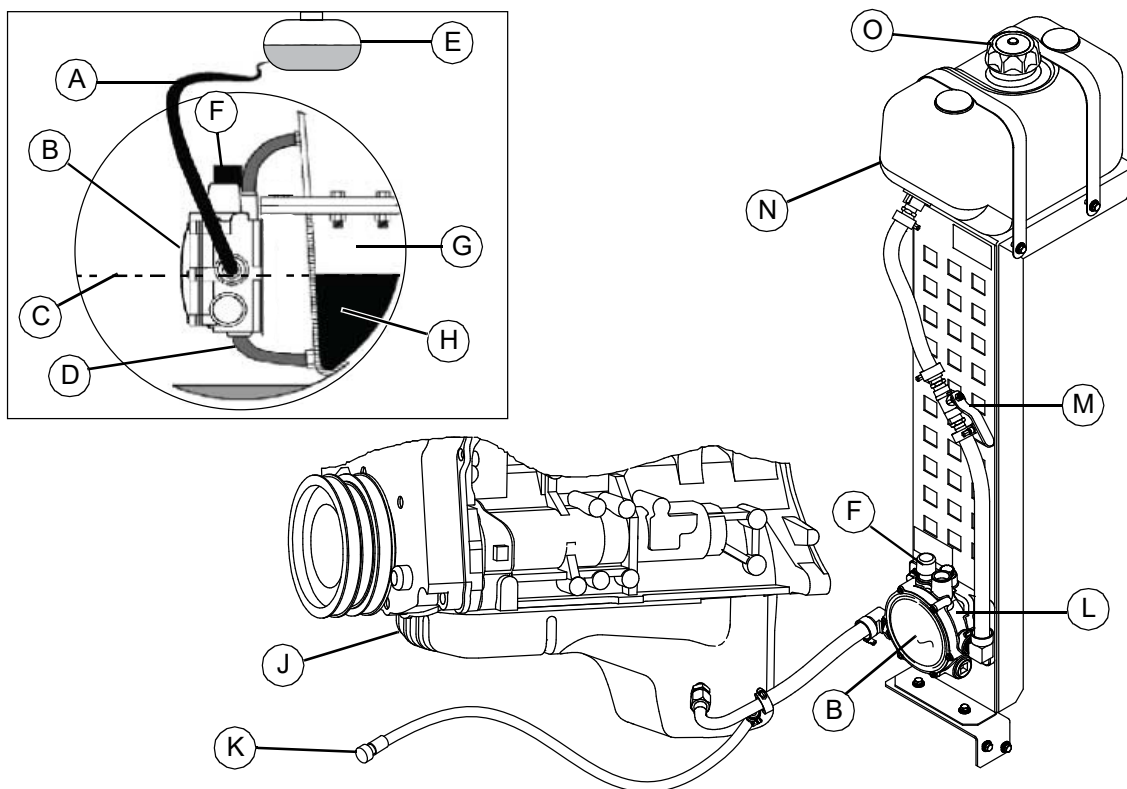

012056

Figure 5-18. Lube Oil Maintainer Assembly and Function Diagram

Item	Item Description	Item	Item Description	Item	Item Description
A	Oil Inlet Hose	F	Test Button	L	Regulator
B	Regulator Viewing Lens	G	Running Engine Crankcase	M	Shutoff Valve
C	Center of Green Bar	H	Oil Level	N	2-1/2 Gallon Oil Supply Tank
D	Crankcase Hose	J	Engine Crankcase Oil Pan	O	Fill Cap
E	Oil Supply Tank	K	Oil Drain Hose		

This page intentionally left blank.

Section 6: Troubleshooting

Engine Troubleshooting

Problem	Cause	Correction
The engine will not crank.	Fuse blown.	Replace 7.5 amp fuse in generator control panel. Correct short circuit condition if fuse blows again.
	Loose, corroded, or defective battery cables.	Tighten, clean, or replace as necessary.*
	Defective starter contact.	Tighten, clean, or replace as necessary.*
	Defective starter motor.	Tighten, clean, or replace as necessary.*
	Dead battery.	Charge or replace battery.
The engine cranks but will not start.	Out of fuel.	Replenish fuel. Turn on fuel valve.
	Defective fuel solenoid.	*
	Open F1 7.5 amp fuse.	Replace F1 7.5 amp fuse if fuse blows again.*
	Open F2 15 amp fuse.	Replace F2 15 amp fuse if fuse blows again.*
	Defective fuel system.	*
	No fuel supply.	Turn on fuel supply.*
The engine starts hard and runs rough.	Air cleaner plugged or damaged.	Check / replace air cleaner.
The generator is set to OFF, but the engine continues to run.	Defective keypad.	*
	Defective control board.	*
There is no AC output from the generator.	Main line circuit breaker is in the OFF (OPEN) position.	Reset circuit breaker to ON (CLOSED) position.
	Generator internal failure.	*
There is no transfer to standby after utility source failure.	Defective transfer switch coil.	*
	Defective transfer relay.	*
	Transfer relay circuit open.	*
	Defective control logic board.	*
Unit consumes large amounts of oil.	Engine over filled with oil.	Adjust oil to correct level.
	Engine breather defective.	*
	Incorrect oil type or viscosity.	See Engine Oil Recommendations .
	Damaged gasket, seal, or hose.	Check for oil leaks.
* Contact an Independent Authorized Service Dealer for assistance.		

Controller Troubleshooting

Active Alarm	Problem	Solution
NOT ACTIVATED	Unit will not start in AUTO with utility loss.	Refer to activation section in Owner's Manual.
NONE	Unit running in AUTO but no power in house.	Check MLCB. Contact Independent Authorized Service Dealer (IASD) if MLCB is in the ON position.
NONE	Unit will not start in AUTO with utility loss.	Check screen for start delay countdown. If the start up delay is greater than expected, contact IASD to adjust from 2 to 1,500 seconds.
HIGH TEMPERATURE	Unit shuts down during operation.	Check ventilation around the intake, exhaust, and rear of generator. Contact IASD if no obstruction is found.
OVERLOAD	Unit shuts down during operation.	Clear alarm and remove loads from the generator. Put back in AUTO and restart.
RPM SENSE LOSS	Unit was running and shuts down, attempts to restart.	Clear alarm and remove loads from the generator. Put back in AUTO and restart. If problem returns, contact IASD to investigate possible fuel issue.
LOW OIL PRESSURE	Unit will not start in AUTO with utility loss.	Check oil level. Add oil per Owner's Manual. Contact IASD if oil level is correct.
RPM SENSE LOSS	Unit will not start in AUTO with utility loss.	Clear alarm. From the MAIN menu on the control panel, navigate to the BATTERY MENU. Contact IASD if battery is GOOD. Replace battery if CHECK BATTERY is displayed.
OVERCRANK	Unit will not start in AUTO with utility loss.	Clear alarm. Attempt to start the unit in MANUAL. If it does not start or starts and runs rough, contact IASD.
OVERSPEED	Unit will not start in AUTO with utility loss.	Contact IASD.
UNDER VOLTAGE	Unit will not start in AUTO with utility loss.	Contact IASD.
UNDERSPEED	Unit will not start in AUTO with utility loss.	Contact IASD.
WIRING ERROR	Unit will not start in AUTO with utility loss.	Verify installation wiring and contact IASD.
OVERVOLTAGE	Unit will not start in AUTO with utility loss.	Contact IASD.
LOW BATTERY	Warning active.	Clear alarm. From the MAIN menu on the control panel, navigate to the BATTERY MENU. Contact IASD if battery is GOOD. Replace battery if CHECK BATTERY is displayed.
BATTERY PROBLEM	Warning active.	Contact IASD.
CHARGER WARNING	Warning active.	Contact IASD.
SERVICE SCHEDULE A	Warning active.	Perform SERVICE SCHEDULE A maintenance; press ENTER to clear.
SERVICE SCHEDULE B	Warning active.	Perform SERVICE SCHEDULE B maintenance; press ENTER to clear.
SERVICE SCHEDULE C	Warning active.	Perform SERVICE SCHEDULE C maintenance; press ENTER to clear.
AUXILIARY SHUTDOWN	Unit will not start in AUTO with utility loss.	Verify both auxiliary shutdown switches are ON (I). See Figure 3-6 for the locations.

Removal From Service During Utility Outages

If, during prolonged utility outages, the user wishes to remove unit from service to conserve fuel, reduce run hours, or to perform maintenance tasks, then complete the steps listed below.

IMPORTANT NOTE: Failure to abide by this procedure can result in equipment damage.

To remove generator from service while running in AUTO and online, proceed as follows:

1. Turn main utility disconnect to OFF (Open).
2. Open viewing window. See [Open Viewing Window](#).
3. Move Main Circuit Breaker switch down to OFF (Open) position.
4. Press OFF on control panel. A red LED will illuminate to confirm system is in OFF mode.

NOTE: If inspection and / or maintenance tasks are to be performed, complete the additional steps listed below.

5. Remove T1 fuse from transfer switch.
6. Pull up rubber flap covering fuse holder and remove 7.5 amp fuse.
7. Remove battery negative cable (black) from battery negative (-) terminal.
8. Place a DO NOT OPERATE tag or placard on both control panel and transfer switch.

To return generator to service, proceed as follows:

NOTE: If inspection and / or maintenance tasks were performed, start with step 1. If unit was just shut down to conserve fuel or to reduce run hours, start at step 5.

1. Install battery negative cable (black) onto battery negative (-) terminal.
2. Pull up rubber flap covering fuse holder and install 7.5 amp fuse.
3. Install T1 fuse in transfer switch.
4. Remove the DO NOT OPERATE tag or placard from both control panel and transfer switch.
5. Press AUTO on control panel. A green LED will illuminate to confirm system is in AUTO mode. Allow generator to start and run for a few minutes.
6. Move Main Circuit Breaker switch up to ON (Closed) position.
7. Turn main utility disconnect to ON (Closed).
8. Close viewing window.

Storage

Prepare For Storage

If generator cannot be exercised every **seven** days and will be out of service longer than 90 days, prepare for storage as follows:

1. Open viewing window. See [Open Viewing Window](#).
2. Press MANUAL on control panel to start engine. A blue LED will illuminate to confirm system is in MANUAL mode.
3. Allow engine to run until it reaches normal operating temperature.
4. Press OFF on control panel. A red LED will illuminate to confirm system is in OFF mode.
5. Move Main Circuit Breaker switch on control panel down to OFF (Open) position.
6. Pull up rubber flap covering fuse holder and remove 7.5 amp fuse.
7. Turn off utility power to transfer switch.
8. Place a DO NOT OPERATE tag or placard on both control panel and transfer switch.
9. Wait five minutes for engine to cool.
10. Remove left and right side access panels. See [Access Panels](#).

NOTE: On 36 kW, 45 kW, and 60 kW models, close shutoff valve to avoid draining oil supply tank with crankcase oil. For more information, see [Lube Oil Maintainer System](#).

11. Remove oil drain hose from holding clamp.
12. Use one wrench to hold hex on hose fitting (to prevent rotation), and use second wrench to remove drain plug.
13. Drain oil into a suitable container.
14. Install drain plug onto end of oil drain hose.
15. Install oil drain hose into holding clamp.
16. Rotate oil filter counterclockwise to remove from oil filter adapter.
17. Apply a light coat of clean engine oil to gasket of **new** oil filter.
18. Install oil filter by hand until gasket just contacts oil filter adapter. Tighten oil filter an additional 3/4 to one full turn.
19. Remove oil fill cap and fill engine with recommended oil. See [Engine Oil Recommendations](#).
20. Install oil fill cap.

NOTE: Dispose of used oil and oil filter at a proper collection center.



WARNING

Explosion. Batteries emit explosive gases. Always disconnect negative battery cable first to avoid spark. Failure to do so could result in death or serious injury. (000238)

21. Remove battery negative cable (black) from battery negative (-) terminal.
22. Remove battery positive cable (red) from battery positive (+) terminal.
23. Remove two screws to release battery hold-down clamp from platform.
24. Remove battery and store in a cool, dry room.
25. Install left and right side access panels. See [Access Panels](#).
26. Thoroughly clean and wipe down generator. See [Corrosion Protection](#).

Return From Storage

To return unit to service after storage, proceed as follows:

1. Thoroughly clean and wipe down generator. See [Corrosion Protection](#).
2. Remove left and right side access panels. See [Access Panels](#).
3. Install battery onto tray oriented with negative (-) post toward front of enclosure.
4. Install two screws with nylon washers to secure battery hold-down clamp to tray.
5. Check battery. See [Check Battery Condition](#).



WARNING

Explosion. Batteries emit explosive gases. Always connect positive battery cable first to avoid spark. Failure to do so could result in death or serious injury. (000133)

6. Install battery positive cable (red) onto battery positive (+) terminal.
7. Install battery negative cable (black) onto battery negative (-) terminal.
8. Check oil level and add oil as necessary. **DO NOT OVERFILL.**

NOTE: On 36 kW, 45 kW, and 60 kW models, open shutoff valve to enable Lube Oil Maintainer System.

9. Open viewing window. See [Open Viewing Window](#).
10. Pull up rubber flap covering fuse holder and install 7.5 amp fuse.
11. Move Main Circuit Breaker switch up to ON (Closed) position.

12. Press MANUAL on control panel to start engine. A blue LED will illuminate to confirm system is in MANUAL mode.
13. Allow engine to run until it reaches normal operating temperature. Check for leaks while engine is running.
14. Press OFF on control panel. A red LED will illuminate to confirm system is in OFF mode.
15. Install left and right side access panels. See [Access Panels](#).
16. Turn on utility power to transfer switch.
17. Press AUTO on control panel. A green LED will illuminate to confirm system is in AUTO mode.
18. Reset time and date.
19. Close viewing window.

Attention After Submersion

Do NOT start and operate the generator if it has been submerged in water. Have an Independent Service Dealer thoroughly clean, dry, and inspect the generator following any submersion. If the structure (home) has been flooded, it should be inspected by a certified electrician to ensure there won't be any electrical problems during generator operation or when utility power is returned.

Part No. 0K8185 Rev. F 12/07/2021
©2021 Generac Power Systems, Inc.

All rights reserved.

Specifications are subject to change without notice.

No reproduction allowed in any form without prior written
consent from Generac Power Systems, Inc.

GENERAC®

Generac Power Systems, Inc.
S45 W29290 Hwy. 59
Waukesha, WI 53189
1-888-GENERAC (1-888-436-3722)
www.generac.com