

# 22 TON

## HORIZONTAL / VERTICAL GAS LOG SPLITTER

**FIRMAN**<sup>®</sup>  
POWER EQUIPMENT

8644 W. LUDLOW DR.  
PEORIA, AZ 85381  
1-844-347-6261

WWW.FIRMANPOWEREQUIPMENT.COM

MODEL // GS2201

MAX.SPLITTING FORCE // 22 TON

OPERATING POSITION // HORIZONTAL / VERTICAL

CYCLE TIME // 11 SECONDS

ENGINE // 6.5HP 196CC FIRMAN

MAX.LOG LENGTH // 24" (610 MM)

CYLINDER // 4" DIAMETER × 22.6" STROKE

PUMP // 14 GPM, 2-STAGE

HYDRAULIC OIL SYSTEM CAPACITY // 4.5 GALLONS

WEDGE // 7" HARDENED STEEL

VALVE // AUTO-RETURN

WHEEL // 16" DOT (4.8-8)

FILTER // SPIN-ON REPLACEABLE

NET WEIGHT // 430 LBS (195 KGS)

GROSS WEIGHT // 511 LBS (232 KGS)

PACKAGE DIMENSIONS // 70" × 27" × 19.5"

CONTAINER QUANTITY // 85 PCS / 40'HQ

MAX TOW SPEED // 45 MPH

HITCH TYPE // 2" BALL COUPLER

EPA CERTIFIED // YES



MAX.LOG  
LENGTH

**24"**



SPLITTER  
FORCE

**22**

**TON**

POWERED BY  
**FIRMAN**

**196cc**  
OHV



HIGH-SPEED  
ROAD TIRES

**16"**



**AUTO-RETURN VALVE**  
Over 300 cycles per hour

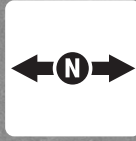

**HARDENED STEEL WEDGE**  
Easily cut through hard wood



**INDUSTRIAL-GRADE FULL BEAM CONSTRUCTION**  
Prevents twisting

**HYDRAULIC HOSE WITH PROTECTION**

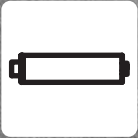

**HYDRAULIC CYLINDER**  
Splits logs up to 24" long

**22 TON GAS LOG SPLITTER**  
11-SECOND CYCLE TIME

**FIRMAN**



**LOG CATCHERS**  
Prevents spit logs from rolling off when split

**HIGH QUALITY FIRMAN 196CC ENGINE**



**EASY TRANSFORMATION**  
Converts from horizontal to vertical in seconds



**BUCHER HYDRAULIC**  
2-stage gear pump with high reliability

**16" HIGH-SPEED ROAD TIRES FOR TOWING**



**2 INCH BALL HITCH COUPLER**  
Fits most ATV/UTV towing applications



**PREMIUM FILTERING HYDRAULIC SYSTEM**  
Prevents contaminants from circulating

# 22 TON

HORIZONTAL / VERTICAL  
GAS LOG SPLITTER

**FIRMAN**<sup>®</sup>  
POWER EQUIPMENT

8644 W. LUDLOW DR.

PEORIA, AZ 85381

1-844-347-6261

WWW.FIRMANPOWEREQUIPMENT.COM

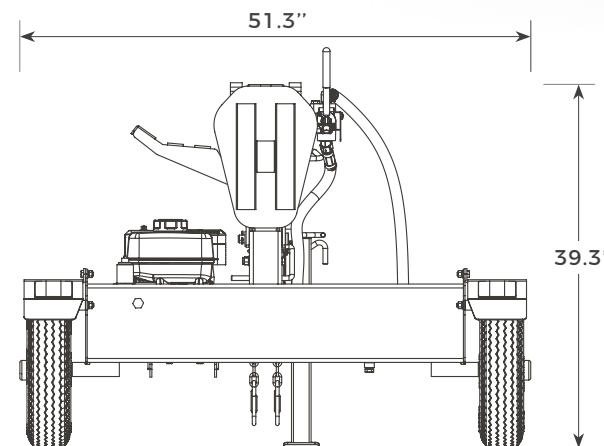
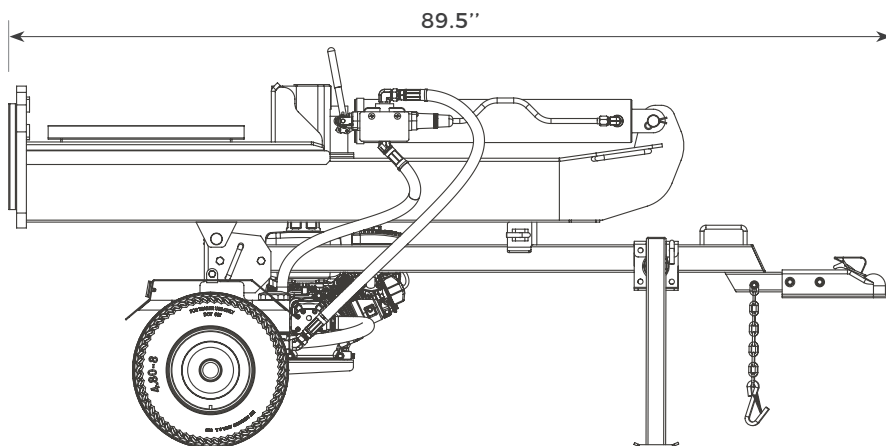



22 TON GAS LOG SPLITTER  
11-SECOND CYCLE TIME

FIRMAN®

196 cc  
OHV

# 22 TON

HORIZONTAL / VERTICAL  
GAS LOG SPLITTER

**FIRMAN**<sup>®</sup>  
POWER EQUIPMENT

8644 W. LUDLOW DR.  
PEORIA, AZ 85381  
1-844-347-6261

[WWW.FIRMANPOWEREQUIPMENT.COM](http://WWW.FIRMANPOWEREQUIPMENT.COM)

