

# Flex Pro Hub/Riot User Manual

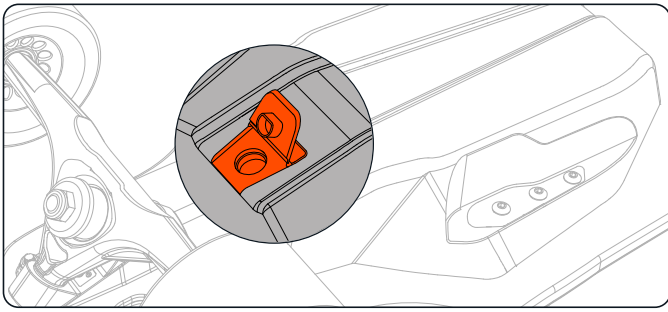



### 防水充电口

必须使用Flex Pro原装充电器进行充电。  
(滑板充满电后,充电器指示灯转为绿灯,充电完毕必须盖好盖子,以保证防水性能。)

CHS

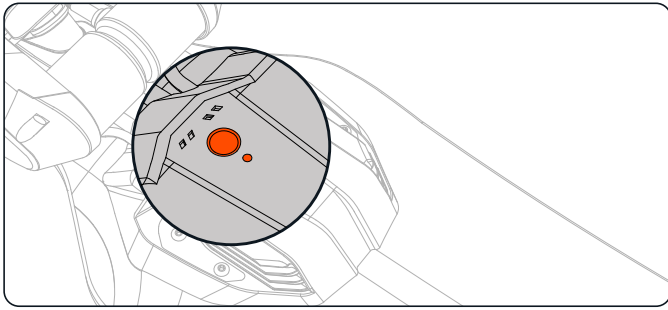

### 电源键开机

待机状态:使用遥控器控制开机,24小时后进入关机状态。(App可自定义待机时间)  
关机状态:长按3秒电源键启动滑板。

滑板指示灯的操作和状态:

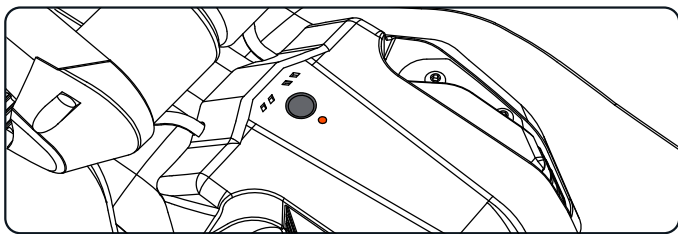

CHS



**开关机**  
长按电源键3s



**绿灯常亮**  
正常工作状态



**红灯慢闪**  
充电中



**配对**  
长按电源键8秒  
(滑板关机状态下)



**红绿灯交替闪烁**  
配对模式



**红灯常亮**  
滑板未连接遥控器



**电机匹配**  
开机后, 连按5下电源键



**绿灯慢闪**  
正常工作状态

## 遥控器操作方法:

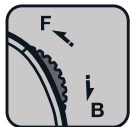
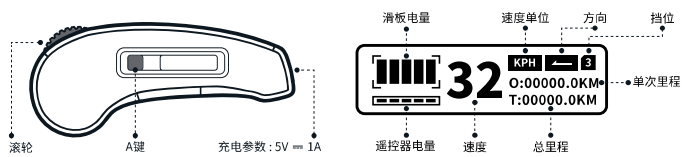

### 加速/刹车

向前推动加速  
向后推动刹车



### 开关机

长按3秒A键



### 设置模式

长按7秒A键  
(遥控器关机状态下)

CHS



### 切换档位

短按1次A键



### 定速巡航

固定油门连接2次A键



### 切换前进方向

连接3次A键



### 坦克模式 (仅适用4WD)

连接4次A键



### TURBO模式开关

连接5次A键



### 限速

连接6次A键

**预警内容:**



遥控器断开连接



ESC 丢失 (仅4WD会出现此提示)



滑板电量过低



滑板电量严重过低



遥控器电量过低



遥控器电量严重过低



ESC 温度过高 (1级)



ESC 温度过高 (2级)



电机过热 (1级)



电机过热 (2级)



滑板电压过高 (1级)



滑板电压过高 (2级)



左电机未连接



右电机未连接

CHS

## 安全须知&免责声明

1. 使用电动滑板与进行其他运动一样具有潜在的风险,可能造成伤害甚至死亡。
2. 使用前必须阅读使用说明书,并佩戴好护具。
3. 皮带在正常使用下会磨损,请参阅Exway相关教程视频,以正确更换损坏的皮带。
4. 请遵循当地交通法律法规,在允许范围内安全使用。
5. 14岁以下儿童、残疾人士、孕妇、老年人等,以及存在精神障碍、疾病、身体正常运动存在障碍的人群禁止使用。
6. 说明书与最终产品可能存在区别,具体请参考Exway App或官方网站提供的最新版本说明书。
7. 有关最新版本的产品手册,请参阅Exway应用程序或官方网站。
8. 若长时间不使用,请每30天对滑板进行一次充放电,以保证电池寿命。

CHS

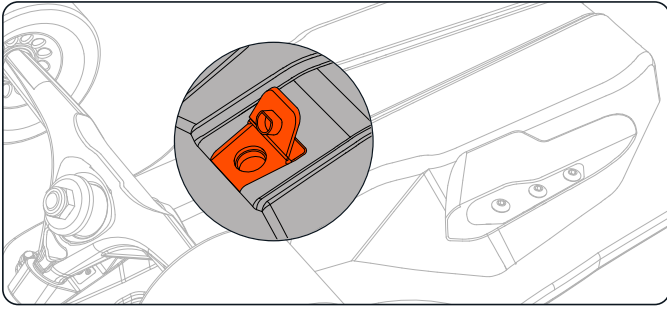

### Water Proof Charging Port

You must use Flex Pro original charger for charging.  
(After the board is fully charged, the charger indicator will turn green, and the cover must be closed after charging to ensure waterproof performance.)

EN

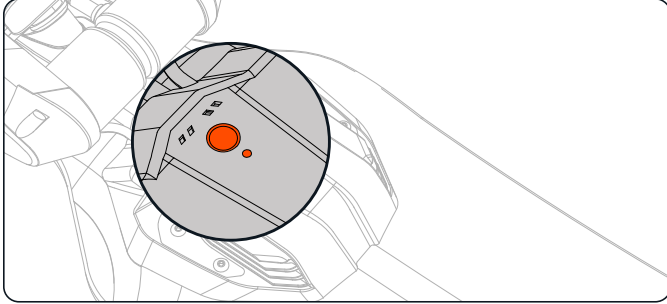

### Power button on

Standby mode: use the remote controller to power on the board , then it will automatically shut off after 24 hours. (Users can use the Exway app to customize the standby time)  
Shutdown mode: Long hold the power button for 3 seconds to turn on the board.

## Indications:

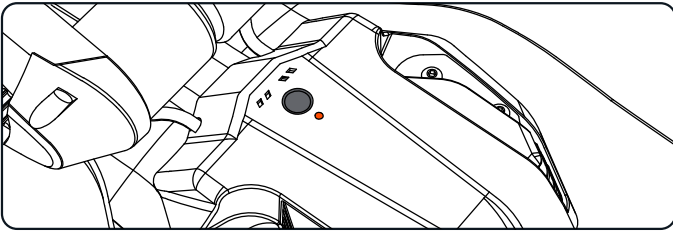

### Power on/of

Hold the button for three seconds



### Continuous green light

Board is turned on



### Red light blinking

Charging

EN



### Pairing

Long press for eight seconds to turn on pair mode when the board is turned off



### Red and green lights flashing

Pairing mode is activated



### Flashing red light

Remote not connected to the board



### Motor Pairing

Press the controller button five times when



### Green light blinking

Updating



## Remote Control Guide:

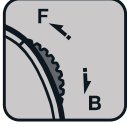
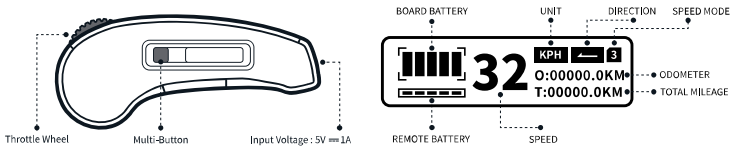

**Accelerate / Brake**

Roll forward to accelerate  
Roll backward to brake



**Switch On/Off**

Hold the Multi-Button for  
three seconds



**Setting Mode**

Hold the multi-Button for  
seven seconds when the  
remote is turned off.



**Change Ride Mode**

Short press the  
Multi-Button



**Cruise Control**

Double press the Multi-Button while  
holding the throttle wheel



**Change Direction**

Triple-press the  
Multi-Button



**Tank Mode (4WD Only)**

Press the Multi-Button  
four times



**Enable Turbo mode**

Press the Multi-Button  
five times



**Speed Limit Mode**

Press the Multi-Button six  
times

## Warnings:



The remote is disconnected from the Board



The battery capacity is below 20%



Remote battery low



Controller temperature is too high



Motor temperature is too high



Voltage is too high



Motor\_L lost



ESC LOST, only happened to 4WD



The battery capacity is below 10%



Remote battery extremely low



Controller is overheating, please stop using your board immediately!



Motors are overheating, please stop using your board immediately!



Voltage is too high, please stop using your board immediately!



Motor\_R lost

EN

## Warnings & Safety Information:

1. Whenever you ride an Exway board, you risk death or serious injury from loss of control, collisions, and falls. To ride safely, you must read and follow all warnings and instructions in this manual.
2. Always wear a helmet when riding. Never ride in water, wet surfaces, in the rain, slippery or uneven surfaces, steep hills, traffic, cracks, train tracks, gravel, rocks, or any obstacles that could cause a loss of traction. Avoid night riding, areas with poor visibility, and narrow spaces.
3. Do not ride an Exway board in environments, on inclines, or at speeds where you would not be safely in control of an unpowered skateboard. In the event of wireless interference or battery fault, you may need to rely on skating techniques like foot-braking or sliding to stop.
4. Please ride responsibly and respect those around you. How you ride will determine how people view this new mode of transportation.
5. The version of the user manual may not be up to date, check out the Exway App or [www.exwayboard.com](http://www.exwayboard.com) to read the most up-to-date version
6. Belts do wear out while riding, make sure to check out instruction videos from Exway to swap your belts properly.
7. If you do not use your board for long periods, please discharge and recharge your board every 30 days.

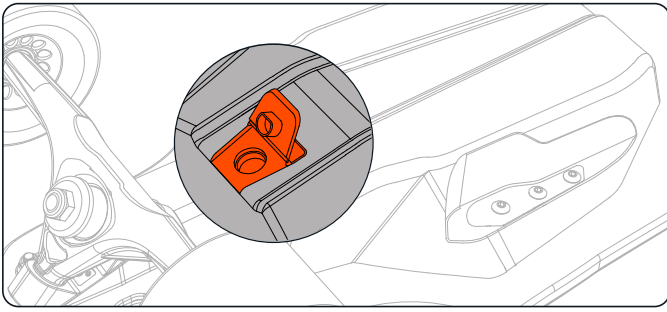

### Wassergeschützter Ladeanschluss

Verwenden Sie zum Aufladen des Boards ausschließlich das originale Exway Flex Pro Ladegerät.  
Die vollständige Akku-Aufladung zeigt das Ladegerät mit grüner LED an. Bringen Sie die Schutzkappe korrekt auf um den Schutz vor Wasser zu gewährleisten.

DE

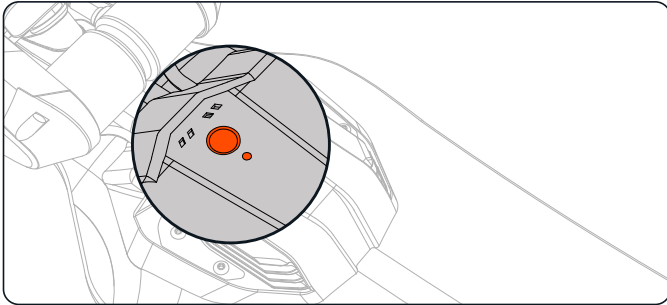

### Das Board einschalten

Sie können das Board während der Standby-Modus mit die Remote einschalten. In der Grundeinstellung wird sich das Board nach 24 Stunden ohne Benutzung ausschalten. Sie können die Einstellungen in das App ändern.  
Drücken Sie den Knopf für drei Sekunden um das Board zu einzuschalten.

## Anzeigen:

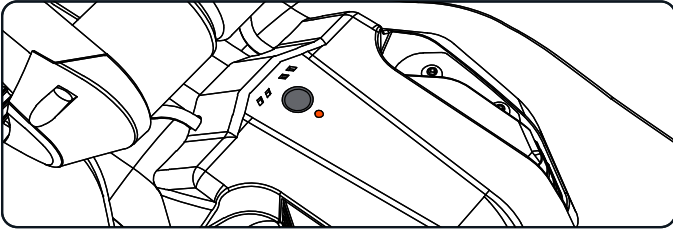

### Power an/aus

Drücken Sie den Knopf für drei Sekunden



### Kontinuierliche grüne

Board ist eingeschaltet



### Red light blinking

Lädt...



### Pairing

Taste 8 Sekunden gedrückt halten um den "Pair-Mode" zu starten



### Rote und grüne Anzeige blinken

"Pairing-Mode" ist aktiv



### Flashing red light

Remote not connected to the board



### Motoranpassung

Drücken Sie die Einschalttaste 5 Mal kurz, nachdem das Skateboard eingeschaltet ist.



### Grünes Licht blinkt

Updating...

## Verwendung der Fernbedienung:

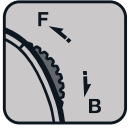
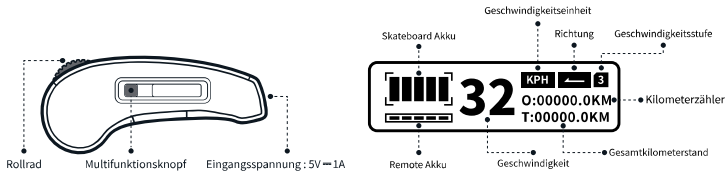

### Beschleunigung / Bremsen

Rad nach vorne drehen um zu beschleunigen  
Rad nach hinten drehen um zu bremsen



### Ein- / Ausschalter

Multifunktionstaste für drei Sekunden halten



### Einstellmodus

Multifunktionstaste für sieben Sekunden drücken um den Einstellmodus zu starten

DE



### Fahrmodus ändern

Multifunktionstaste kurz drücken



### Tempomat

Multifunktionstaste doppelklicken während das Einstellrad halten



### Richtungswechsel

Multifunktionstaste drei Mal drücken



### Panzer-Modus (Tank Mode, 4WD-Modelle)

Multifunktionstaste vier Mal drücken

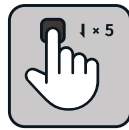

### Turbo-Modus aktivieren

Multi-Knopf 5 Mal drücken



### Geschwindigkeitsbegrenzer-Modus

Multifunktionstaste sechs Mal drücken

## Warnings:



Die Fernbedienung ist nicht verbunden

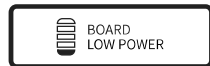

Ladezustand der Batterie unter 10%



Niedriger Akkustand der Fernbedienung



Board-Controller heiß



Motortemperatur zu hoch



Batteriespannung zu hoch

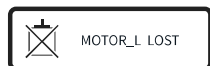

Linker Motor nicht verbunden

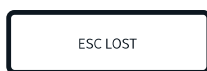

ESC verloren, passiert nur bei 4WD



Ladezustand der Batterie unter 20%

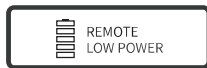

Sehr niedriger Akkustand der Fernbedienung



Board-Controller überhitzt: Umgehend das Board nicht mehr benutzen!



Motor überhitzt: Umgehend das Board nicht mehr benutzen!



Batteriespannung zu hoch: Umgehend das Board nicht mehr benutzen!



Rechter Motor nicht verbunden

## Sicherheitshinweise:

1. Wenn Sie ein Exway-Board fahren, riskieren Sie Tod oder schwere Verletzungen durch Kontrollverlust, Kollisionen und Stürze. Um sicher zu fahren, müssen Sie alle Warnungen und Anweisungen in diesem Handbuch lesen und befolgen.
2. Tragen Sie beim Fahren immer einen Helm. Fahren Sie niemals auf Wasser, nassen Oberflächen, bei Regen, rutschigen oder unebenen Oberflächen, steilen Hügeln, Verkehr, Rissen, Bahngleisen, Kies, Steinen oder Hindernissen, die zu einem Traktionsverlust führen könnten. Vermeiden Sie Nachtfahrten, Bereiche mit schlechter Sicht und enge Räume.
3. Fahren Sie kein Exway-Board in Umgebungen, an Steigungen oder bei Geschwindigkeiten, bei denen Sie die Kontrolle über ein nicht angetriebenes Skateboard nicht sicher haben würden. Im Falle einer Funkstörung oder eines Batteriefehlers müssen Sie sich möglicherweise auf Skating-Techniken wie Fußbremsen oder Sliden verlassen, um anzuhalten.
4. Bitte fahren Sie verantwortungsbewusst und respektieren Sie die Menschen um Sie herum. Wie Sie fahren, bestimmt, wie die Menschen dieses neue Transportmittel sehen.
5. Die Version des Benutzerhandbuchs ist möglicherweise nicht auf dem neuesten Stand. Lesen Sie die Exway-App oder [www.exwayboard.com](http://www.exwayboard.com), um die aktuellste Version zu lesen
6. Antriebsriemen verschleißten während der Fahrt! Verwenden Sie Anleitungsvideos von Exway, um zu überprüfen wie Sie die Riemen richtig ersetzen.
7. Wenn Sie Ihr Board längere Zeit nicht benutzen, entladen Sie es bitte alle 30 Tage und laden Sie es wieder auf.

DE



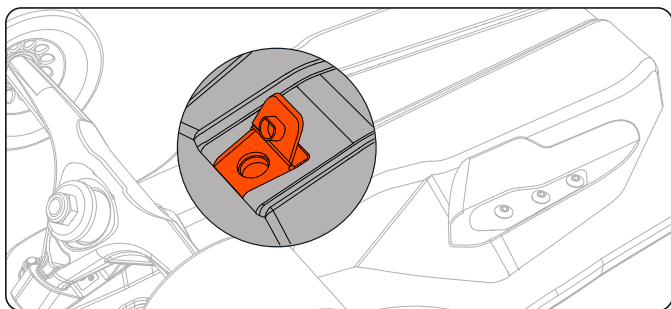

### Port de charge étanche

La charge doit être effectuée à l'aide d'un chargeur Flex Pro original.  
(une fois que la plaque coulissante est complètement chargée, l'indicateur du chargeur devient Vert, et le couvercle doit être recouvert après le chargement pour assurer l'étanchéité.)

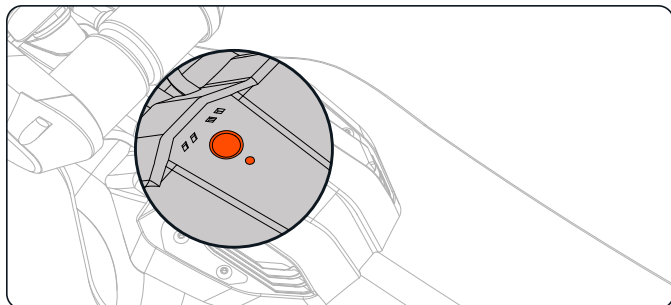

### Mise en marche avec le bouton d'alimentation

État de veille : utilisez la télécommande pour mettre en marche, et passez à l'état d'être éteint après 24 heures. (L'application peut personnaliser le temps de veille)  
État éteint : appuyez longuement sur le bouton d'alimentation pendant 3 secondes pour démarrer le skateboard.

## Fonctionnement et état de l'indicateur de skateboard:

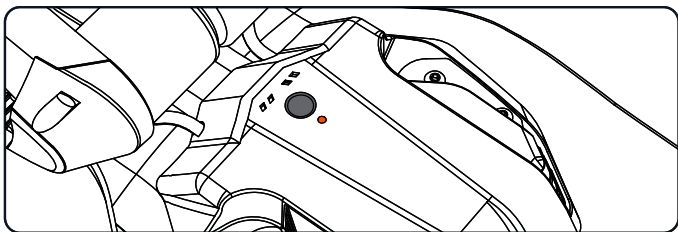

### Conversion de

Appuyez sur le bouton d'alimentation et maintenez-le



### Vert fixeAnzeige

Conditions de travail normales



### Feu rouge

En charge

FR



### Paire

Appuyez sur le bouton d'alimentation et maintenez-le enfoncé pendant 8 secondes (lorsque la planche à roulettes est éteinte)



### Les feux de signalisation clignotent en alternance

Mode d'appariement



### La lumière rouge est toujours allumée

Charger



### compatibilité

appuyer brièvement 5 fois sur le bouton ON après que le skate soit allumé



### Les feux de signalisation clignotent en alternance

Mode d'appariement

## manuel d'utilisation de la télécommande:

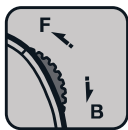
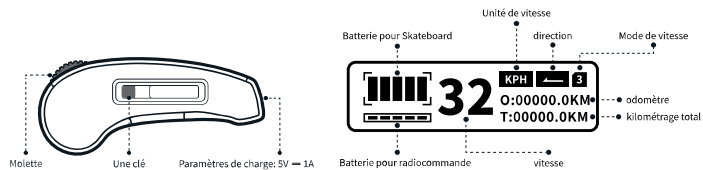

### Accélération / freinage

Avancez et accélérez  
Repousser le frein



### Conversion de machine

Appuyez sur le bouton A  
et maintenez-le enfoncé  
pendant 3 secondes



### Mode de réglage

Appuyez sur le bouton A  
et maintenez-le enfoncé  
pendant 7 secondes  
(lorsque la télécom-  
mande est éteinte)



### Changement de vitesse

Appuyez une fois  
brièvement sur la touche A



### Régulateur de vitesse

Appuyez deux fois sur le bouton A  
pour verrouiller l'accélérateur



### Retournement

Appuyez 3 fois sur la  
touche A



### Mode réservoir (4 roues motrices uniquement)

Appuyez 4 fois sur la  
touche A



### Commutateur Turbo

Appuyez 5 fois sur la  
touche A



### Limitation de vitesse

Appuyez 6 fois sur la  
touche A

## Contenu d'avertissement:



Déconnexion de la télécommande



ESC LOST, Only happened to 4WD



Batterie de skateboard trop faible (20%)



Batterie de skateboard trop faible (10%)



La télécommande est trop basse



Sehr niedriger Akkustand der Fernbedienung



Température ESC trop élevée (niveau 1)



La température de la batterie est trop élevée (niveau 2)



Surchauffe du moteur (niveau 1)



Surchauffe du moteur (niveau 2)



La tension de la planche à roulettes est trop élevée (niveau 1)



La tension de la planche à roulettes est trop élevée (niveau 2)



Moteur gauche non connecté



Moteur droit non connecté

FR

## Consignes de sécurité et avis de non-responsabilité

1. L'utilisation de planches à roulettes électriques présente les mêmes dangers potentiels que tout autre sport, ce qui peut entraîner des blessures ou même la mort.
2. Avant utilisation, assurez-vous de lire le manuel d'instructions et de porter un équipement de protection.
3. La courroie s'usant dans des conditions normales d'utilisation, veuillez vous référer à la vidéo du didacticiel Exway correspondante pour remplacer correctement la courroie endommagée.
4. Veuillez l'utiliser en toute sécurité dans la plage autorisée conformément au code de la route local.
5. Les enfants de moins de 14 ans, les personnes handicapées, les femmes enceintes, les personnes âgées, etc. qui ont des troubles mentaux, des maladies et des troubles normaux des mouvements physiques sont interdits d'utiliser le produit.
6. Il peut y avoir des différences entre le manuel et le produit final. Pour plus de détails, veuillez vous référer à la dernière version du manuel fournie sur l'application Exway ou sur le site officiel.
7. Pour obtenir la dernière version du manuel du produit, reportez-vous à l'application Exway ou au site Web officiel.
8. S'il n'est pas utilisé pendant une longue période, veuillez charger et décharger la planche à roulettes tous les 30 jours pour assurer la durée de vie de la batterie.

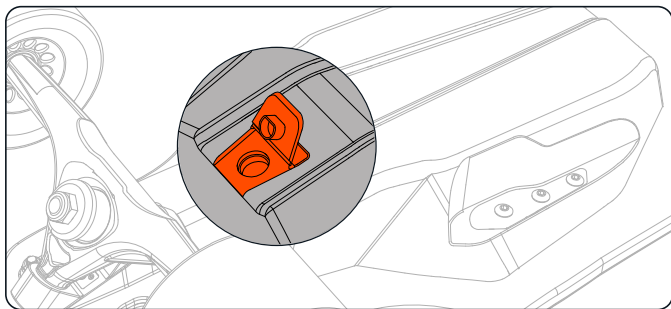

### 防水電気口

Flex Pro のオリジナル充電器を使って充電しなければなりません。  
(スケートボードが電気で満たされたら、充電器のパイロットランプが青になり、充電が終わったら必ずカバーを閉めて、防水性能を保證します。)

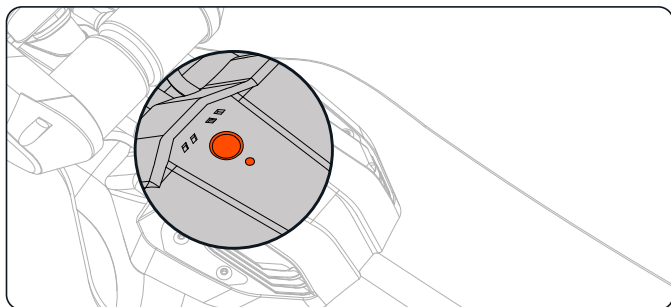

JP

### 電源キーのオン

待機状態: リモコンを使って起動を制御し、24時間後にシャットダウン状態に入ります。アプリは待機時間をカスタマイズできます)  
シャットダウン状態: 3秒の電源ボタンを長押ししてスライドを起動します。

## スケートボードインジケータの操作とステータス:

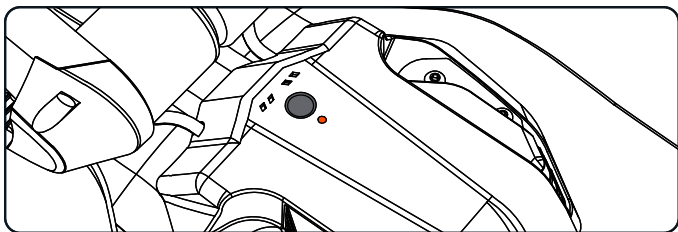

### 開関機

TTL 電源ボタン 3s



### 安定した緑色

通常の作業状態



### 赤く点滅

充電中



### ペア

電源ボタンを8秒間長押しします  
(スケートボードがオフの場合)



### 信号が交互に点滅します

ペアリングモード



### 赤信号は常に点灯していま

スケートボードがリモコンに  
接続されていません



### モーターマッピング

電源を入れた後、電源ボタン  
を5回短く押します



### 緑色のライトがゆっくり点滅

アップグレード

## リモコンの操作方法:

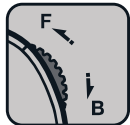
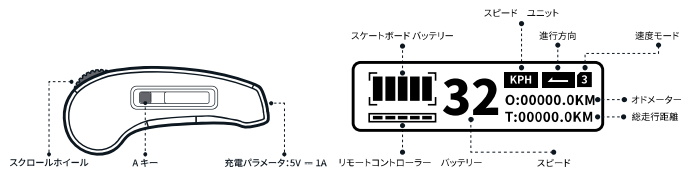

### 加速/ブレーキ

前進して加速する  
ブレーキを後方に押す



### スイッチマシン

Aボタンを3秒間長押し  
します



### モードを選択する

Aボタンを7秒間長押ししま  
す (リモコンがオフの場合)

JP



### 開閉装置

Aキーを1回短く押す



### クルーズコントロール

Aボタンを2回押してスロット  
ルを固定します



### 方向を切り替える

Aキーを3回押す



### タンクモード (4WDのみ)

Aキーを4回押す



### TURBOスイッチ

Aキーを5回連続で押す



### 速度制限

Aキーを6回押す



警告内容:



リモコンが切断されました



ESCロスステロス(4WDのみ)



スケートボードのバッテリー  
が低すぎます(10%)



スケートボードのバッテリー  
が低すぎる(20%)



バッテリーの低下



バッテリー切れ



ESC温度が高すぎる(レベル1)



ESC温度が高すぎる(レベル2)



モーターの過熱(レベル1)



モーターの過熱(レベル2)



スケートボードの電圧が高  
すぎる(レベル1)



スケートボードの電圧が高  
すぎる(レベル2)



左モーターの未接続



右モーターの未接続

JP

## 安全上の注意と免責事項:

1. . 電動スケートボードの使用には、他のスポーツと同じ潜在的なリスクがあり、怪我や死亡の原因となる可能性があります。
2. 使用する前に、取扱説明書を読み、保護具を着用する必要があります。
3. ベルトは通常の使用で摩耗します。損傷したベルトを正しく交換するには、関連する Exway チュートリアルビデオを参照してください。
4. 地域の交通法規制に従い、許可された範囲内で安全に使用してください。
5. 14 歳未満のお子様、身体の不自由な方、妊婦、お年寄り等、精神障害、病気、正常な運動障害のある方のご利用はご遠慮ください。
6. マニュアルと最終製品は異なる場合があります。詳しくは、Exway アプリまたは公式サイトに掲載されている最新版のマニュアルをご覧ください。
7. 製品マニュアルの最新バージョンについては、Exway アプリまたは公式 Web サイトを参照してください。
8. 長期間使用しない場合は、バッテリーの寿命を延ばすために、30 日ごとにスケートボードを充電および放電してください。

JP

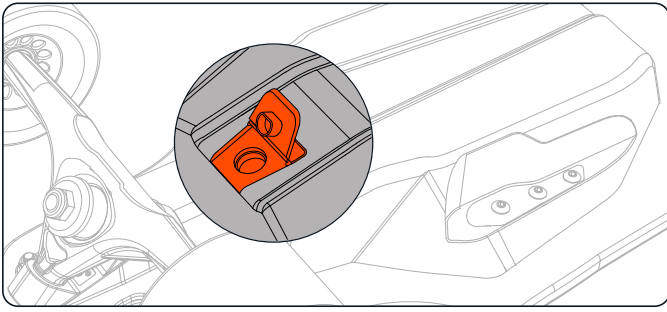

### 방수 충전 포트

Flex Pro 오리지널 충전기를 사용해 충전해야 한다.  
(스케이트 보드가 충전되면 충전기 표시등이 녹색등으로 바뀌고 충전이 끝나면 반드시 뚜껑을 잘 닫아 방수 성능을 확보해야 한다.)

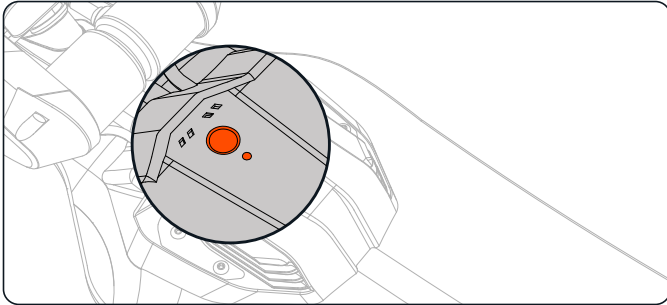

### 전원 키 작동

대기 상태: 리모컨으로 작동을 제어하고 24시간 후에 전원이 꺼지는 상태에 들어간다.(App에서 대기 시간을 사용자 정의할 수 있음)  
전원 끄기 상태: 전원 버튼을 3초 동안 길게 누르면 스케이트 보드가 작동됩니다.

**스케이트 보드 표시기의 작동 및 상태 :**

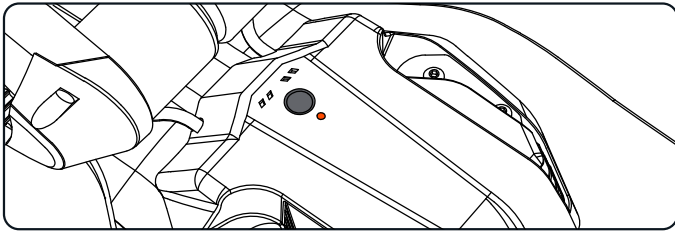

**기계 전환**

전원 버튼을 3 초 동안 길게 누릅니다



**녹색으로 계속 켜져 있음**

정상적인 근무 조건



**빨간불 천천히 충전**

충전



**쌍**

전원 버튼을 8 초 동안 길게 누릅니다  
(스케이트 보드가 꺼져있을 때)



**신호등이 번갈아 깜박입니다**

페어링 모드



**빨간불은 항상 켜져**

스케이트 보드가 리모컨에 연결되어 있지 않습니다



**모터 매칭**

전원을 켜후 전원버튼을 연속 5번 누릅니다



**녹색불 천천히 깜박임**

업그레이드 중

KR

**리모콘 사용 방법 :**

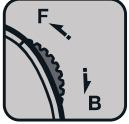
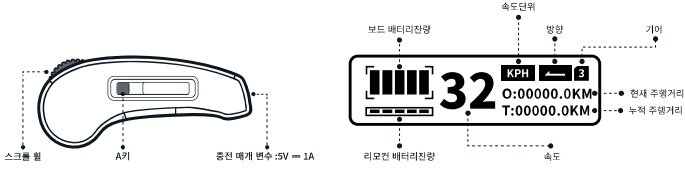

**가속 / 브레이크**

앞으로 나아가고 가속화하십시오



**기계 전환**

A 버튼을 3 초 동안 길게 누릅니다



**설정 모드**

A 버튼을 7 초 동안 길게 누릅니다 (리모컨이 꺼져있을 때)



**기어 전환**

A 키를 한 번 짧게 누릅니다



**크루즈 컨트롤**

A 버튼을 두 번 눌러 스포들을 고정하십시오



**방향 전환**

A 키를 3 번 누릅니다



**탱크 모드 (4WD 만 해당)**

A 키를 4 번 누릅니다



**TURBO 스위치**

A버튼 연속 5회 누르기



**속도 제한**

A 키를 6 번 누릅니다

KR

**경고 내용:**



원격 제어 연결 해제



스케이트 보드 배터리가 너무 낮음 (10 %)



리모콘 배터리가 너무 낮음

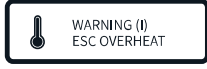

ESC 온도가 너무 높습니다 (레벨 1)

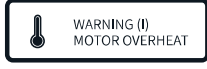

모터 과열 (레벨 1)



스케이트 보드 전압이 너무 높습니다 (레벨 1)



왼쪽 모터가 연결되지 않음



ESC 없음 (4WD에만 이 알림 표시됨)



스케이트 보드 배터리가 너무 낮음 (20 %)



리모콘 배터리가 매우 낮음



ESC 온도가 너무 높습니다 (레벨 2)



모터 과열 (레벨 2)



스케이트 보드 전압이 너무 높습니다 (레벨 2)



오른쪽 모터가 연결되지 않음

KR

## 안전 지침 및 면책 조항

1. 전기 스케이트 보드의 사용은 다른 스포츠와 동일한 잠재적 위험을 가지고있어 부상이나 사망까지 초래할 수 있습니다.
2. 사용하기 전에 사용 설명서를 읽고 보호 장비를 착용해야 합니다.
3. 정상적인 사용시 벨트가 마모되므로 관련 Exway 튜토리얼 동영상을 참조하여 손상된 벨트를 올바르게 교체하십시오.
4. 현지 교통 법규에 따라 허용 범위 내에서 안전하게 사용하시기 바랍니다.
5. 14 세 미만의 어린이, 장애인, 임산부, 노인 등 정신 장애, 질병, 정상적인 신체 운동에 장애가있는 분은 사용을 금합니다.
6. 매뉴얼과 최종 제품은 차이가 있을 수 있으며 자세한 사항은 Exway App 또는 공식 홈페이지에서 제공하는 매뉴얼의 최신 버전을 참고하시기 바랍니다.
7. I 제품 매뉴얼의 최신 버전은 Exway 앱 또는 공식 웹 사이트를 참조하세요.
8. 장시간 사용하지 않을 경우 배터리 수명을 보장하기 위해 스케이트 보드를 30 일마다 충전 및 방전하십시오.

KR



WARRANTY CARD

Name: \_\_\_\_\_ Telephone Number: \_\_\_\_\_

E-mail: \_\_\_\_\_

Address: \_\_\_\_\_

Serial Number: \_\_\_\_\_ Date of Purchase: \_\_\_\_\_

Purchased From: \_\_\_\_\_

Issue:

- Unbootable
- Charging
- Problems while riding
- Remote
- Motor
- Other(Truck/Gripe Tape/Wheels/Charger)

Maintenance history:

- Have you taken it apart ?
- Have you upgraded the firmware?
- Was it ever water-damaged ?
- Is the light on at the charging port ?

Description of the issue: \_\_\_\_\_

Exway's Feedback and Solution:



## Security Warning & Disclaimer

---

1. Please read and understand the user manual before riding your Exway electric skateboard. You are responsible for the operation and control of the electric skateboard and you must know how to control it before you ride.
2. Riding an Exway electric skateboard is extremely dangerous. Whenever you ride your Exway board you risk great bodily injury, disability, or death from loss of control, collision, or falls.
3. The Exway electric skateboard can lose connection with the remote control. If this happens the skateboard becomes a non-motorized longboard. Please always ride within your ability to control the board in case power loss occurs. Be prepared to lose braking ability at any time.
4. Skate only in an open area free from vehicles and pedestrian traffic, and other physical obstacles. You are responsible for learning the basic features of the board such as braking, accelerating, and switching gears. Always wear a helmet and full protective gear while riding.
5. Do not ride on slippery or uneven surfaces. Only ride in areas with good visibility. Avoid riding in close proximity to vehicles and pedestrian traffic.
6. The Exway electric skateboard is not a toy and is not intended for children under 16.
7. Please refer to the Exway APP or the official website for the latest version of the product manual.

## Maintenance

---

1. When storing your Exway, the ideal battery level should be between 30% and 75%. If you are storing your board for long periods of time please charge and ride it at least once a month.
2. Do not place your Exway near an open fire or in areas where the temperature is exceedingly hot.
3. Do not store your Exway in wet or damp conditions in order to avoid short circuits and electrical malfunctions.

## Special Notes

---

1. The warranty is valid for 6 months and is non-transferable.
2. The warranty starts on the date the board is purchased. The customer must be able to provide proof of purchase and be within the 6-month purchase period.
3. Wear and tear items (grip tape, wheels, bearings, and rubber bushings) are not covered under warranty.
4. Damages caused by improper use, improper maintenance, improper storage, or unauthorized repairs will void the warranty.



iOS



Android



- 扫描二维码下载APP获得电子版说明书
- Scan QR code to download the App and get the most up-to-date version of the user manual.
- Scannen Sie den QR-Code, um die App herunterzuladen und die aktuellste Version des Benutzerhandbuchs zu erhalten.
- Scannez le code QR pour télécharger l'application afin d'obtenir la version électronique du manuel.
- QRコードをスキャンしてAPPをダウンロードし、電子版のマニュアルを入手してください
- QR 코드를 스캔하여 앱을 다운로드하여 매뉴얼의 전자 버전을 받으십시오.

---

**进阶设置/Find Us Here/Finden Sie uns hier/Réglages avancés/高度な設定/고급 설정**

Exway Store :  
[www.exwayboard.com](http://www.exwayboard.com)

Learn More :  
<https://www.youtube.com/channel/UCZ74glv3YkLdcz30dJE1flw>  
(YouTube Channel:Exwayboard)

(YouTube Channel:Exwayboard)

<https://space.bilibili.com/78880290/video>



PANTONE Black 6 C

(标题/深色)



PANTONE Black 7 C

(图案辅助色)



PANTONE Cool Gray 10 C

(正文/图案辅助色)



PANTONE Cool Gray 3 C

(图案辅助色)



PANTONE 1655 C

(logo色/强调色)

封面跟尾页二维码单面印刷 其他的双面印刷

尺寸:105\*147mm