

VEVOR[®]

TOUGH TOOLS, HALF PRICE

Technical Support and E-Warranty Certificate www.vevor.com/support

CONCRETE SAW OWNER'S MANUAL

MODEL: DC425

We continue to be committed to provide you tools with competitive price.

"Save Half", "Half Price" or any other similar expressions used by us only represents an estimate of savings you might benefit from buying certain tools with us compared to the major top brands and does not necessarily mean to cover all categories of tools offered by us. You are kindly reminded to verify carefully when you are placing an order with us if you are actually saving half in comparison with the top major brands.

DC425

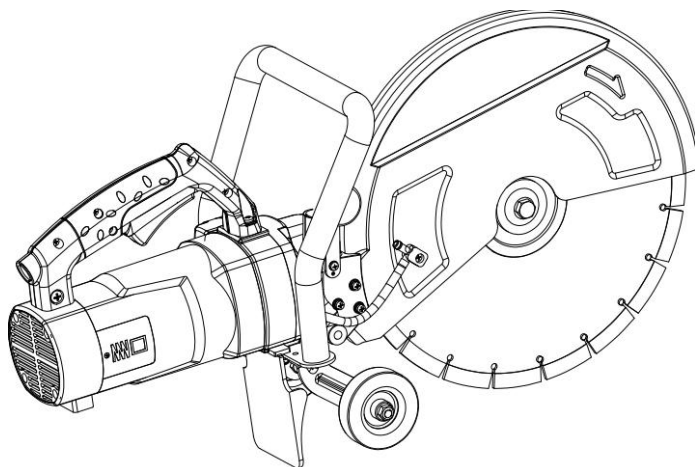

<Picture Only For Reference >

NEED HELP? CONTACT US!

Have product questions? Need technical support? Please feel free to contact us:

✉ CustomerService@vevor.com

This is the original instruction, please read all manual instructions carefully before operating. VEVOR reserves a clear interpretation of our user manual. The appearance of the product shall be subject to the product you received. Please forgive us that we won't inform you again if there are any technology or software updates on our product.

MAIN CONSTRUCTION

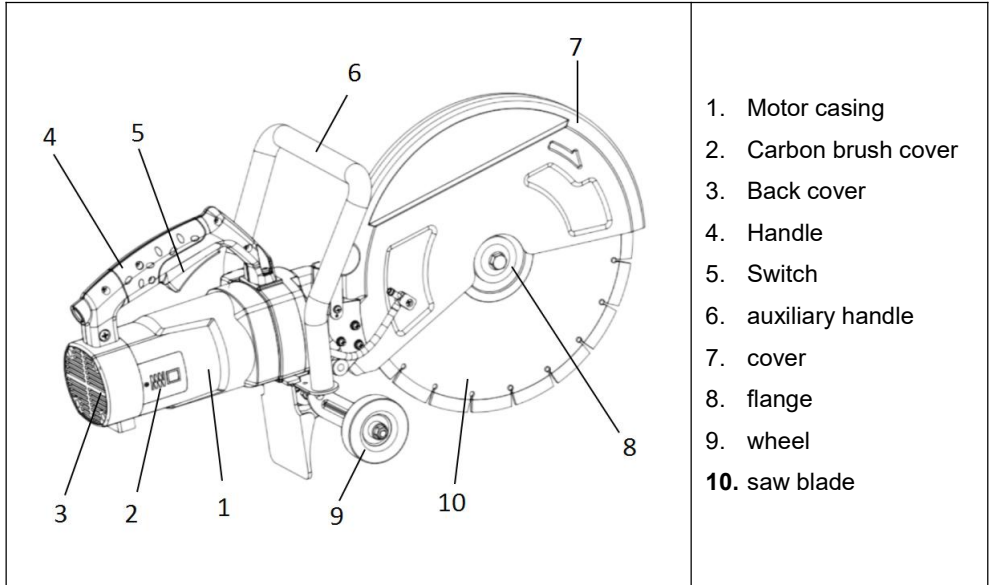

MAIN SPECIFICATIONS

Model	Power Supply(V/Hz)	Input(W)	Maximum Cutting Depth (inch)	Saw Blade Size(mm)	No-load speed (RPM)	G.W. (kg)
DC425	120/60	3200	6	φ410	3200	19.5

MARKINGS

The manufacturer is required to apply the following markings:

- Products shall be marked with the markings specified by the particular product standard.
- Products certified for Canada shall have all Caution and Warning markings in both English and French.

Additional bilingual markings not covered by the product standard(s) may be required by the Authorities Having Jurisdiction. It is the responsibility of the manufacturer to provide and

apply these additional markings, where

[For products eligible to bear the cCSAus Mark, (i.e., the product is certified and manufactured to the requirements of BOTH Canadian and U.S. Standards), the Markings section of the report shall include the following statement:]

The products listed are eligible to bear the CSA Mark shown with adjacent indicators 'C' and 'US' for Canada and US (indicating that products have been manufactured to the requirements of both Canadian and U.S. Standards) or with adjacent indicator 'US' for US only or without either indicator for Canada only.

applicable, in accordance with the requirements of those authorities.

Tools shall be marked with:

- The submittor's name and/or master contract number "300374", adjacent to the CSA Monogram with the C US Indicator;
- model or type reference;
- Rated voltage(s) or rated voltage range(s), in volts;
- Symbol for nature of supply, unless the rated frequency is marked;
- Rated input, in watts or rated current, in amperes;
- name or trade mark or identification mark and address of the manufacturer or any other agent responsible for placing the tool on the market;;
- Any mandatory mark showing compliance with legislation by reference to this standard.
- "WARNING: To reduce the risk of injury, user must read instruction manual. «MISE EN GARDE – Pour réduire le risque de blessures, l'utilisateur doit lire le manuel d'instructions» or equivalent or symbol M002 of ISO 7010



- M002 of ISO 7010
- date of manufacture.
- rated speed in revolutions per minute;
- rated capacity in mm;
- tools provided with a threaded spindle shall be marked with spindle thread size;
- WARNING Always wear eye protection, "AVERTISSEMENT Toujours porter des lunettes

de sécurité” or equivalent or the sign M004 of ISO 7010 or the following safety sign:



The eye protection symbol may be modified by adding other personal protective equipment such as ear protection, dust mask, etc

WARNING To reduce the risk of injury, use proper guard and use only accessories rated at least equal to the maximum speed marked on the tool.

In Canada, the equivalent French wording is as follows: “AVERTISSEMENT Pour réduire le risque de blessure, utiliser un carter approprié et uniquement les accessoires convenant au moins à la vitesse maximale indiquée sur l’outil.”

For cut-off machines with a permanently fixed guard, the following alternative warning may be used:

WARNING To reduce the risk of injury, use only accessories rated at least equal to the maximum speed marked on the tool.

In Canada, the equivalent French wording is as follows: “AVERTISSEMENT Pour réduire le risque de blessure, utiliser uniquement les accessoires convenant au moins à la vitesse maximale indiquée sur l’outil.”

Note: Minimum 2.4mm high letters for "WARNING".

INSTRUCTIONS See standard CAN/CSA-C22.2 No. 60745-1-07 + UPD 1, 2, 3, (UL 60745-1-4th (Nov.28, 2016) and CAN/CSA-C22.2 No. 60745-2-22-12+UPD 1 (reaffirmed 2017, (UL 60745-2-22-1st (June 19, 2014)) for details.

An instruction manual and safety instructions shall be provided with the tool and packaged in such a way that is noticed by the user when the tool is removed from the packaging. The

safety instructions may be separate from the instruction manual. An explanation of the symbols required by this standard shall be provided in either the instruction manual or the safety instructions.

They shall be written in the official language(s) of the country in which the tool is sold.

They shall be legible and contrast with the background.

They shall include the name and address of the manufacturer or supplier or any other agent responsible for placing the tool on the market.

The General Power Tool Safety Warnings and the specific tool Safety Warnings, if in English, shall be verbatim and in any other official language to be equivalent.

Format of all Safety Warnings must differentiate, by font highlighting or similar means, the context of clauses as illustrated below.

General Safety Rules

WARNING! Read all safety warnings and all instructions. Failure to follow the warnings and instructions may result in electric shock, fire and/or serious injury. Save all warnings and instructions for future reference. The term "power tool" in all of the warnings listed below refers to your mains-operated (corded) power tool or battery-operated (cordless) power tool.

1) Work area safety

- a) Keep work area clean and well lit. Cluttered or dark areas invite accidents.
- b) Do not operate power tools in explosive atmospheres, such as in the presence of flammable liquids, gases or dust. Power tools create sparks which may ignite the dust or fumes.
- c) Keep children and bystanders away while operating a power tool. Distractions can cause you to lose control.

2) Electrical safety

- a) Power tool plugs must match the outlet. Never modify the plug in any way. Do not use any adapter plugs with earthed (grounded) power tools. Unmodified plugs and matching

outlets will reduce risk of electric shock.

b) Avoid body contact with earthed or grounded surfaces, such as pipes, radiators, ranges and refrigerators. There is an increased risk of electric shock if your body is earthed or grounded.

c) Do not expose power tools to rain or wet conditions. Water entering a power tool will increase the risk of electric shock.

d) Do not abuse the cord. Never use the cord for carrying, pulling or unplugging the power tool. Keep cord away from heat, oil, sharp edges or moving parts. Damaged or entangled cords increase the risk of electric shock.

e) When operating a power tool outdoors, use an extension cord suitable for outdoor use. Use of a cord suitable for outdoor use reduces the risk of electric shock.

f) If operating a power tool in a damp location is unavoidable, use a ground fault circuit interrupter (GFCI) protected supply. Use of an GFCI reduces the risk of electric shock.

3) Personal safety

a) Stay alert, watch what you are doing and use common sense when operating a power tool. Do not use a power tool while you are tired or under the influence of drugs, alcohol or medication. A moment of inattention while operating power tools may result in serious personal injury.

b) Use personal protective equipment. Always wear eye protection. Protective equipment such as dust mask, non-skid safety shoes, hard hat, or hearing protection used for appropriate conditions will reduce personal injuries.

c) Prevent unintentional starting. Ensure the switch is in the off-position before connecting to power source and/or battery pack, picking up or carrying the tool. Carrying power tools with your finger on the switch or energising power tools that have the switch on invites accidents.

d) Remove any adjusting key or wrench before turning the power tool on. A wrench or a key left attached to a rotating part of the power tool may result in personal injury.

e) Do not overreach. Keep proper footing and balance at all times. This enables better control of the power tool in unexpected situations.

f) Dress properly. Do not wear loose clothing or jewellery. Keep your hair, clothing and gloves away from moving parts. Loose clothes, jewellery or long hair can be caught in moving parts.

g) If devices are provided for the connection of dust extraction and collection facilities,

ensure these are connected and properly used. Use of dust collection can reduce dust-related hazards.

4) Power tool use and care

- a) Do not force the power tool. Use the correct power tool for your application. The correct power tool will do the job better and safer at the rate for which it was designed.
- b) Do not use the power tool if the switch does not turn it on and off. Any power tool that cannot be controlled with the switch is dangerous and must be repaired.
- c) Disconnect the plug from the power source and/or the battery pack from the power tool before making any adjustments, changing accessories, or storing power tools. Such preventive safety measures reduce the risk of starting the power tool accidentally.
- d) Store idle power tools out of the reach of children and do not allow persons unfamiliar with the power tool or these instructions to operate the power tool. Power tools are dangerous in the hands of untrained users.
- e) Maintain power tools. Check for misalignment or binding of moving parts, breakage of parts and any other condition that may affect the power tool's operation. If damaged, have the power tool repaired before use. Many accidents are caused by poorly maintained power tools.
- f) Keep cutting tools sharp and clean. Properly maintained cutting tools with sharp cutting edges are less likely to bind and are easier to control.
- g) Use the power tool, accessories and tool bits etc. in accordance with these instructions, taking into account the working conditions and the work to be performed. Use of the power tool for operations different from those intended could result in a hazardous situation.

5) Service

- a) Have your power tool serviced by a qualified repair person using only identical replacement parts. This will ensure that the safety of the power tool is maintained.
Special requirement for cutting off tool

Cut-off machine safety warnings

- a) The guard provided with the tool must be securely attached to the power tool and positioned for maximum safety, so the least amount of wheel is exposed towards the operator. Position yourself and bystanders away from the plane of the rotating wheel.

The guard helps to protect operator from broken wheel fragments and accidental contact with wheel.

b) Use only bonded reinforced or diamond cut-off wheels for your power tool. Just because an accessory can be attached to your power tool, it does not assure safe operation.

c) The rated speed of the accessory must be at least equal to the maximum speed marked on the power tool. Accessories running faster than their rated speed can break and fly apart.

d) Wheels must be used only for recommended applications. For example: do not grind with the side of cut-off wheel. Abrasive cut-off wheels are intended for peripheral grinding, side forces applied to these wheels may cause them to shatter.

e) Always use undamaged wheel flanges that are of correct diameter for your selected wheel. Proper wheel flanges support the wheel thus reducing the possibility of wheel breakage.

f) Do not use worn down reinforced wheels from larger power tools. Wheels intended for a larger power tool are not suitable for the higher speed of a smaller tool and may burst.

NOTE The above warning does not apply for tools only designated to be used with diamond wheels.

g) The outside diameter and the thickness of your accessory must be within the capacity rating of your power tool. Incorrectly sized accessories cannot be adequately guarded or controlled.

h) The arbour size of wheels and flanges must properly fit the spindle of the power tool. Wheels and flanges with arbour holes that do not match the mounting hardware of the power tool will run out of balance, vibrate excessively and may cause loss of control.

i) Do not use damaged wheels. Before each use, inspect the wheels for chips and cracks. If power tool or wheel is dropped, inspect for damage or install an undamaged wheel. After inspecting and installing the wheel, position yourself and bystanders away from the plane of the rotating wheel and run the power tool at maximum no load speed for one minute. Damaged wheels will normally break apart during this test time.

j) Wear personal protective equipment. Depending on application, use face shield, safety goggles or safety glasses. As appropriate, wear dust mask, hearing protectors, gloves and shop apron capable of stopping small abrasive or workpiece fragments. The eye protection must be capable of stopping flying debris generated by various operations. The dust mask or respirator must be capable of filtering particles generated by your operation. Prolonged exposure to high intensity noise may cause hearing loss.

k) Keep bystanders a safe distance away from work area. Anyone entering the work area must wear personal protective equipment. Fragments of workpiece or of a broken wheel may fly away and cause injury beyond immediate area of operation.

l) Hold the power tool by insulated gripping surfaces only, when performing an operation where the cutting accessory may contact hidden wiring or its own cord. Cutting accessory contacting a "live" wire may make exposed metal parts of the power tool "live" and could give the operator an electric shock.

m) Position the cord clear of the spinning accessory. If you lose control, the cord may be cut or snagged and your hand or arm may be pulled into the spinning wheel.

n) Never lay the power tool down until the accessory has come to a complete stop. The spinning wheel may grab the surface and pull the power tool out of your control.

o) Do not run the power tool while carrying it at your side. Accidental contact with the spinning accessory could snag your clothing, pulling the accessory into your body.

p) Regularly clean the power tool's air vents. The motor's fan will draw the dust inside the housing and excessive accumulation of powdered metal may cause electrical hazards.

q) Do not operate the power tool near flammable materials. Sparks could ignite these materials.

r) Do not use accessories that require liquid coolants. Using water or other liquid coolants may result in electrocution or shock.

Further safety instructions for abrasive cutting-off operations

Kickback and related warnings

Kickback is a sudden reaction to a pinched or snagged rotating wheel. Pinching or snagging causes rapid stalling of the rotating wheel which in turn causes the uncontrolled power tool to be forced in the direction opposite of the wheel's rotation at the point of the binding.

For example, if an abrasive wheel is snagged or pinched by the workpiece, the edge of the wheel that is entering into the pinch point can dig into the surface of the material causing the wheel to climb out or kick out. The wheel may either jump toward or away from the operator, depending on direction of the wheel's movement at the point of pinching. Abrasive wheels may also break under these conditions.

Kickback is the result of power tool misuse and/or incorrect operating procedures or conditions and can be avoided by taking proper precautions as given below.

a) Maintain a firm grip on the power tool and position your body and arm to allow you to resist kickback forces. Always use auxiliary handle, if provided, for maximum control over kickback or torque reaction during start-up. The operator can control torque reactions

or kickback forces, if proper precautions are taken.

- b) Never place your hand near the rotating accessory. Accessory may kickback over your hand.
- c) Do not position your body in line with the rotating wheel. Kickback will propel the tool in direction opposite to the wheel's movement at the point of snagging.
- d) Use special care when working corners, sharp edges etc. Avoid bouncing and snagging the accessory. Corners, sharp edges or bouncing have a tendency to snag the rotating accessory and cause loss of control or kickback.
- e) Do not attach a saw chain, woodcarving blade, segmented diamond wheel with a peripheral gap greater than 10 mm or toothed saw blade. Such blades create frequent kickback and loss of control.
- f) Do not "jam" the wheel or apply excessive pressure. Do not attempt to make an excessive depth of cut. Overstressing the wheel increases the loading and susceptibility to twisting or binding of the wheel in the cut and the possibility of kickback or wheel breakage.
- g) When wheel is binding or when interrupting a cut for any reason, switch off the power tool and hold the power tool motionless until the wheel comes to a complete stop. Never attempt to remove the wheel from the cut while the wheel is in motion otherwise kickback may occur. Investigate and take corrective action to eliminate the cause of wheel binding.
- h) Do not restart the cutting operation in the workpiece. Let the wheel reach full speed and carefully re-enter the cut. The wheel may bind, walk up or kickback if the power tool is restarted in the workpiece.
- i) Support panels or any oversized workpiece to minimize the risk of wheel pinching and kickback. Large workpieces tend to sag under their own weight. Supports must be placed under the workpiece near the line of cut and near the edge of the workpiece on both sides of the wheel.

j) Use extra caution when making a “pocket cut” into existing walls or other blind areas. The protruding wheel may cut gas or water pipes, electrical wiring or objects that can cause kickback.

OPERATING INSTRUCTIONS

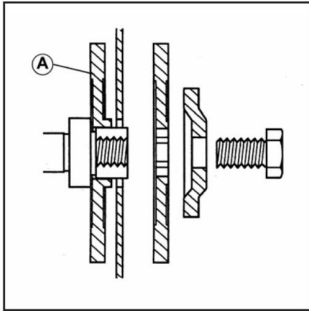

OPERATING INSTRUCTIONS

INSTALLING/REMOVING A DISC

WARNING: Always disconnect the machine from the power supply before attempting to install or remove a Cutting Disc.

- Ensure that the machines arbor and the blade flanges are clean and free from dust and debris.
- Ensure that the direction of rotation marked on the blade matches the direction of rotation marked on machines guard.

Note: this machine is supplied with



Note: The arbor bolt has a left hand thread .Turn counter clockwise to tighten the arbor . turn clockwise to loosen the arbor bolt.

To remove a cutting disc ,reverse the above installation procedure.

USING A DUST EXTRACTION MACHINE

A workshop dust extraction machine can be attached to disc cutter.

WARNING: Dust can be very dangerous. We strongly recommend that a suitable dust extraction machine (not supplied) is used with this machine to keep the workplace as clean and safe as possible.

The suction hose from the dust extraction machine should be attached to dust extraction port of the disc cutter.



FIG. 4

- Remove the rubber cap from the dust extraction port and store it safely for future use .
- Push the connection hose from the dust extraction machine into the dust extraction port of the disc cutter(FIG.4)
- Follow all instructions supplied with the dust extraction machine when using such with the Disc cutter.
- Ensure that the hose and power cable of any attached dust extraction machine do not pose or cause a trip or any other form of hazard to the operator.
- when the dust extraction machine is no longer required remove it from the disc cutter and replace cap to the dust extraction port.

THE ON/OFF TRIGGER SWITCH

This machine is equipped with a safety start trigger switch.

To start the tool:

- Push in the safety lock button (Fig.5a) on the side of the handle with your thumb.
- Depress the main trigger switch (Fig.5b) to start the motor.

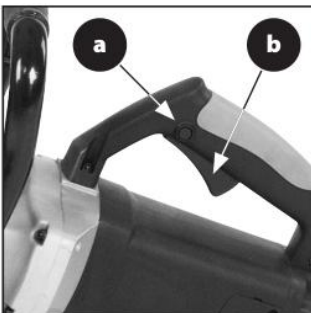

FIG. 5a & 5b

WARNING: Never start the saw with the cutting edge of the saw blade in contact with the workpiece surface.

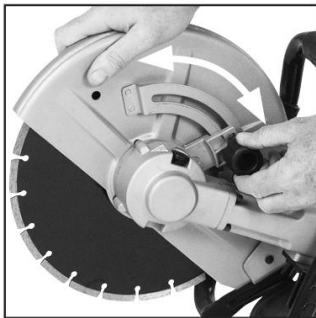

FIG. 6

CUTTING ADVICE

PRE-CUTTING ADVICE

- Ensure that the power supply matches the requirements specified on the matches the requirements specified on the machines rating plate.
- Ensure that the machine trigger switch is in the “OFF” position. If the machine is connected to a power source with trigger switch the “ON” position , the machine could start operating immediately with the possibility of a serious accident occurring.
- If an extension cable is required it must be a suitable type for use outdoors and so labeled.
- The manufacturers instructions should be followed when using an extension cable.
- Route any extension cable so that it does not pose a trip (or any other) hazard to the operator to any bystanders.

WHEEL GUARD ADJUSTMENT

The wheel guard is adjustable and should be positioned to provide the operator with the best combination of personal protection and visibility of cutting area.

- Loosen the wheel gard locking knob and rotate the guard to the required position. (FIG.6)
- Securely tighten the wheel guard locking knob to lock the guard in place.

Note: the tightness of this locking knob and the security of the wheel guard should be checked regularly when operations commence.

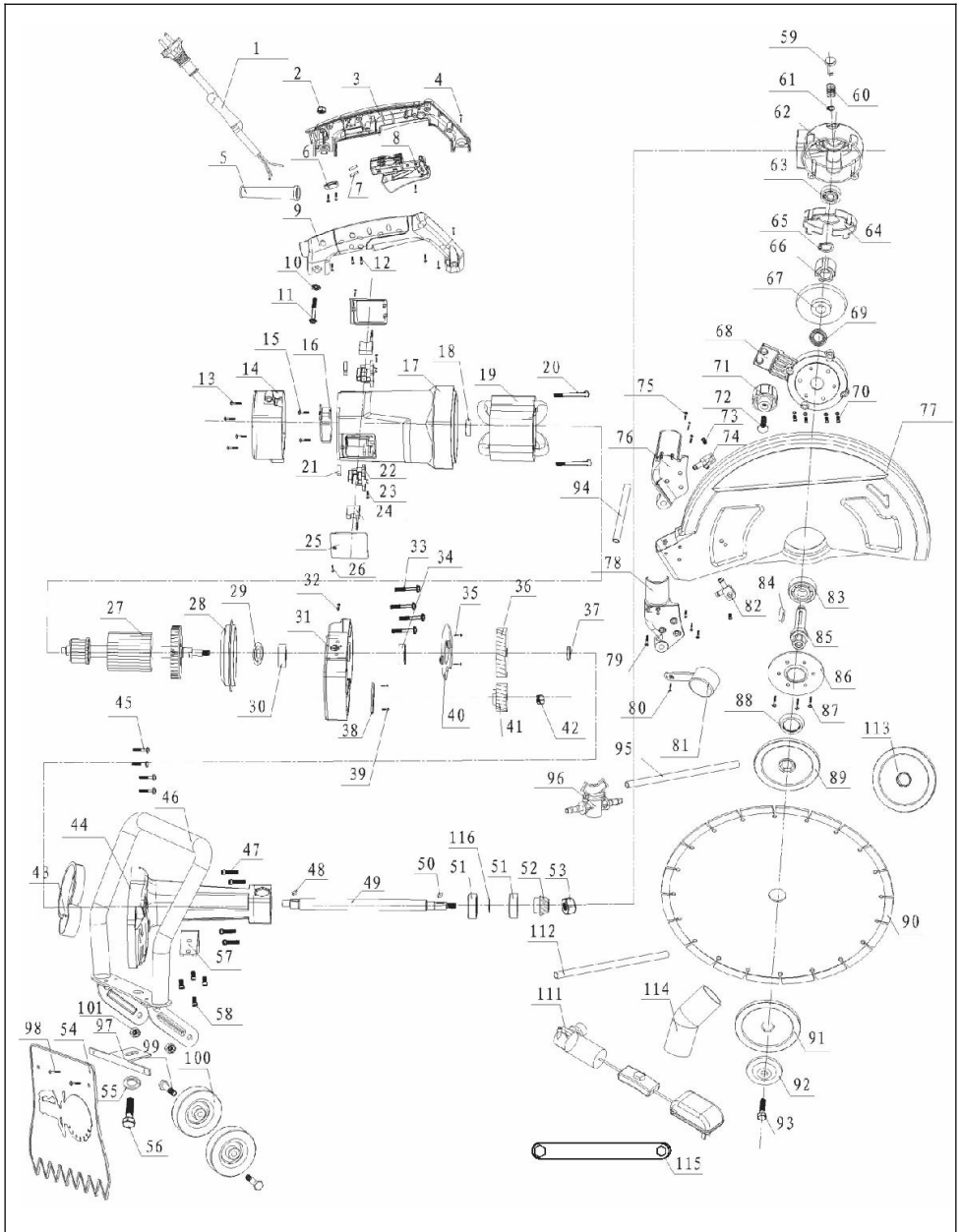

No	Part Description	Qty	No	Part Description	Qty
1	Cable wire	1	37	Gear washer	1
2	Nut M6	1	38	bearing pressure plate	1
3	Left handle	1	39	Screw M4x10	2
4	Screw M5x20	2	40	oil baffle	1
5	Cable sheath	1	41	Gear	1
6	Tension	1	42	Nut M8	1
7	wiring buckle	2	43	oil baffle	1
8	switch	1	44	Gear box	1
9	right handle	1	45	Screw M5x25	4
10	M6 washer	1	46	Handle	1
11	Screw M6x25	1	47	Sctew M6x45	4
12	Screw ST4x15	8	48	Key 4x4x14	1
13	Screw ST5x24	4	49	Drive shaft	1
14	Motor End Cover	1	50	Key 3x3x14	1
15	Screw ST4x15	2	51	Bearing 6301RS	2
16	Soft Starter	1	52	gear	1
17	Motor Housing	1	53	Nut M8	1
18	Bearing 609 RS	1	54	Breakwater	1
19	Stator	1	55	spring washer M12	1
20	Screw ST5x80	2	56	Screw M12x15	1
21	Spring	2	57	Fixed plate	1
22	Brush Holder	2	58	Screw M6x16	4
23	Screw ST4x10	2	59	Lockpin	1
24	Brush	2	60	Lockpin-spring	1
25	Brush cover	2	61	Circlip for shaft 6	1
26	Screw ST3x8	2	62	Gear box	1
27	Rotor	1	63	Bearing 6200Z	1
28	baffle	1	64	oil baffle	1
29	Bearing washer	1	65	Circlip for shaft 15	1
30	Bearing 6202 RS	1	66	Axle sleeve	1
31	Gear box	1	67	Bevel gear	1

32	Screw M4x10	1	68	Gear cover	1
33	Screw ST5x40	4	69	O-ringφ60x1.5	1
34	Bearing 6200 RS	1	70	Screw M6x16	4
35	Screw M4x10	2	71	Locking handwheel	1
36	Gear	1	72	Squar Bolt M8x24	1
No	Part Description	Qty	No	Part Description	Qty
73	Screw M5x10	2	98	Screw M5x10	2
74	Outlet	1	99	Bolt 35	2
75	Screw M5x10	6	100	wheel	2
76	Dust outlet (R)	1	101	Lock nut M8	2
77	Guard	1	102		1
78	Dust outlet (L)	1	103		1
79	Screw M4x30	1	104		1
80	Screw M4x10	1	105		1
81	Dust outlet cover	1	106		1
82	Outlet	1	107		1
83	Bearing 6302Z	1	108		1
84	Key 4x4x30	1	109		1
85	Spindle	1	110		1
86	Bearing pressure plate	1	111	Water pump	1
87	Screw M6x16	3	112	Pvc water pipe 6x8	1
88	Dustproof ring	1	113	Flange	1
89	Flange	1	114		1
90	saw blade	1	115	16#wrench	1
91	flange	1	116	washer	1
92	Washer	1	117	Hexagon Wrench	1
93	Screw	1	118	Bottom plate	1
94	Pvc water pipe 8x10 (230mm)	1			

95	Pvc water pipe 8x10 (5000mm)	1			
96	Tap	1			
97	Breakwater -plate	1			

Importer: WAITCHX

Address: 250 bis boulevard Saint-Germain 75007 Paris

Importer: FREE MOOD LTD

Address: 2 Holywell Lane, London, England, EC2A 3ET

Manufacturer: Wuyi Bohai Electric Tools Co., Ltd.

Address: Che Men Tou, Tongqin Industrial Park, Wuyi, Zhejiang, China

MADE IN CHINA

VEVOR[®]

TOUGH TOOLS, HALF PRICE

TechnicalSupport and E-Warranty Certificate

www.vevor.com/support