

## User Manual

*BigBlue supports environmental sustainability.  
Scan the QR code using a smartphone device,  
for the latest user manual in different languages.*



# IMPORTANT SAFETY INSTRUCTION

## Product Disclaimer:

Actual product may vary. BigBlue reserves the right to the final interpretation of the contents in this manual and all documents associated with this product. We also reserve the right to update, change or terminate this manual without prior notice. If you have any questions or comments, please contact us at [support@ibigblue.com](mailto:support@ibigblue.com).

Read all the instructions.

Keep these instructions.

Heed all warnings.

Follow all instructions.

Failure to operate the product correctly may result in damage to the product or personal property, and cause serious injury.

BigBlue will not be held liable for damages caused by fire, earthquake, accidents, intentional misconduct on the part of the customer abuse or other abnormal conditions.

BigBlue reserves the right to the final interpretation of the contents of this user manual.

**⚠ WARNING:** This product can expose you to chemicals such as Di (2-ethylhexyl) phthalate (DEHP), which is known to the State of California to cause cancer and birth defects or other reproductive harm. For more information go to [www.P65Warnings.ca.gov](http://www.P65Warnings.ca.gov)

## Product Use:

DO NOT expose this product to water or moisture.

DO NOT place the product near a heat source or under high temperature, such as inside the car with direct sunlight, a fire source, an operating stove, or other product that produces heat. No naked flame sources, such as lighted candles, should be placed on the product.

DO NOT repair any damage to the AC plug or power supply on your own.

Unplug the product when unused for a long period of time.

**WARNING:** To reduce the risk of electric shock, do not remove the cover (or back) as there are no user-serviceable parts inside. Refer servicing to qualified personnel.

DO NOT block any ventilation openings.

Clean only with a dry cloth.

Keep the product out of reach of children and pets.

This product is not recommended for powering medical emergency equipment related to personal safety, not limited to medical grade ventilators Continuous Positive Airway Pressure (CPAP), or artificial lungs (ECMO). Consult your doctor with the manufacturer for restrictions on the use of the product.

Refer all servicing to qualified service personnel. Servicing is required when the product has been damaged in any way, such as a power supply cord or plug is damaged, liquid has been spilled or objects have fallen into the product, the product has been exposed to rain or moisture, does not operate normally, or has been dropped.

## Product Charging:

Always use BigBlue-provided charging cables. BigBlue assumes no responsibility for any consequences of product misuse, including but not limited to charging with an unsuitable wall outlet, circuit, or power cable. Doing so will void the warranty.

When charging, please place the product on the ground with no flammable or combustible materials around it. To prevent accidents, never leave the product unattended during charging.

DO NOT charge the product immediately after a long or heavy load. The temperature of the product may be too high. Charge the product till it cools down to room temperature.

# IMPORTANT SAFETY INSTRUCTION

## Product Storage:

If a low-battery warning appears, charge the product before storing it. Otherwise, long-term storage may cause damage to the battery cells of the product.

DO NOT place the product near a heat source or under high temperatures, such as inside the car with direct sunlight, a fire source, or an operating stove.

Store the product in a dry environment and at room temperature.

Ensure no objects will fall on or around the product while it is being stored.

## Product Disposal:

WARNING: Attention should be drawn to the environmental aspects of battery disposal.

Dispose of the product in specific recycling boxes only after a complete discharge. Strictly follow the local regulations on battery disposal and recycling.

## Product Maintenance:

The optimal operating temperature is 50°F - 86°F / 10°C to 30°C.

The recommended storage temperature is -4°F - 113°F / -20°C to 45°C.

If the product is not used for a long time, the life cycle of battery cells will reduce. Please recharge the unit at least every three months.

## Product Certifications:



## Warranty Conditions:

No dealer nor distributor may vary the terms of this warranty which is personal to the original purchaser and is not transferable.

Please retain the sales receipt as proof of purchase.

Warranty claims must wherever possible be made through the Dealer from whom the product was purchased.

## This warranty excludes:

- Damage caused through neglect, accident, misuse, wear, and tear, or incorrect installation, adjustment, or repair by unauthorized personnel. Any unauthorized servicing will result in loss of warranty.
- The above conditions do not affect your statutory rights as a consumer.

# CONTENTS

## BigBlue CellPowa 1000 – Blue-Eyed Boy

<b>INTRODUCTION</b>	5
Output Ports	
Input Ports	
Unpacking The Equipment	
<b>CONTROLS AND FUNCTIONS</b>	6
Product Indications	
Liquid-crystal Display Indications	
<b>SYSTEM OPERATIONS</b>	8
Powering On / Off	
Power Saving Mode	
Recharging Mode – AC Input	
Recharging Mode – Solar Panel	
Recharging Mode – Car Cigarette Lighter Socket	
Charging Mode – AC Outputs	
Charging Mode – DC Outputs (USB Type-A, USB Type-C)	
Charging Mode – DC Outputs (Car Cigarette Lighter Socket, DC 5521)	
LED Flashlight	
Utmost-B™ Charging Mode (boost-up mode)	
Pass-through Charging	
10ms Uninterruptible Power Supply	
<b>SYSTEM SPECIFICATIONS</b>	14
<b>FREQUENTLY ASKED QUESTIONS</b>	15
<b>TROUBLESHOOTING</b>	16
<b>WARRANTY CARD</b>	18

# INTRODUCTION

## Introduction of BigBlue CellPowa 1000 – Blue-Eyed Boy

Thank you for your investment in the BigBlue CellPowa 1000. Nestled between the CellPowa 600 and CellPowa 2500, the new BigBlue CellPowa 1000 fuses premium traits into a pricing category that follows the mantra of a high-performance pure sine wave LiFePO4 portable power station that is denoted as a market-favorable Blue-Eyed Boy (Fair-Haired Boy)!

Outwardly resembling the sequential series, the BigBlue CellPowa 1000 enhances the CellPowa 600 with a larger 1,075 watt-hours capacity, extra AC wattage up to a total of 2,000W, in addition to bi-directional USB PD Type-C ports, and more features to combat your heavy energy-consumed life!

Please read this manual to obtain the best performance from your BigBlue CellPowa 1000. Scan the QR code below using your smartphone to download the latest user manual version.

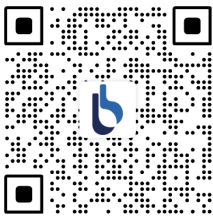

## Output Ports

- AC: Up to a total of 1,000W (2,000W surge power) / pure sine wave  
US: 120V / 8.33A, 60Hz  
EU / UK: 230V / 4.35A, 50Hz  
JP: 100V / 10A, 50 / 60Hz  
AU: 240V / 4.17A, 50Hz  
CN: 220V / 4.55A, 50Hz
- Utmost-B™ Charging (boost-up mode): 2,000W
- USB Type-A (2 x fast-charging ports, 18W each): 5V / 3A, 9V / 2A, 12V / 1.5A; up to 36W
- USB PD Type-C (2 ports, 45W each): 5V, 9V, 12V, 15V / 3A; 20V / 2.25A; up to 90W
- USB PD Type-C (2 ports, 100W each): 5V, 9V, 12V, 15V, 20V / 5.0A; up to 200W
- DC 5521 (2 ports, 60W each): 12V / 5A; up to total 120W
- Car Cigarette Lighter Socket: 12V / 10A; up to 120W

## Input Ports

- AC Charge: Superior fast-recharging 600W
- Solar Charger (2 x DC5525 ports): 12 - 30V / 6.2A; 300W max
- Car Lighter Charger: 12 - 24V / 5A; 120W max

## Unpacking The Equipment

The carton should contain:

- The BigBlue CellPowa 1000, portable power station
- One AC charging cable
- One MC4-to-DC 5525 cable
- One car charger-to-DC 5525 cable
- One accessory bag
- One user manual

# CONTROLS AND FUNCTIONS

## Product Indications

\*\* May vary by country or region

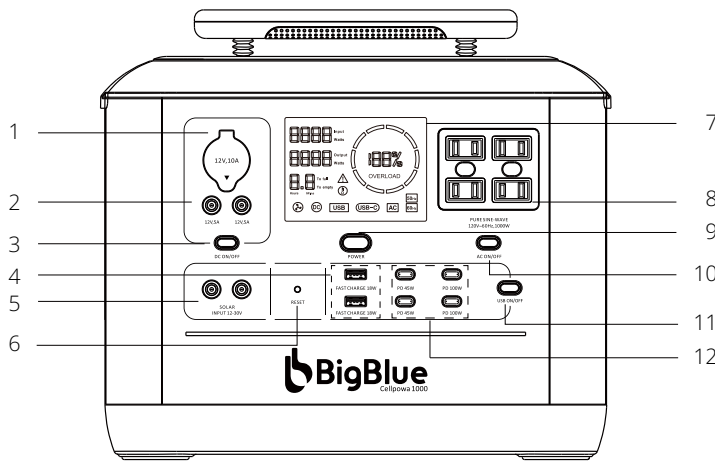

Front Panel

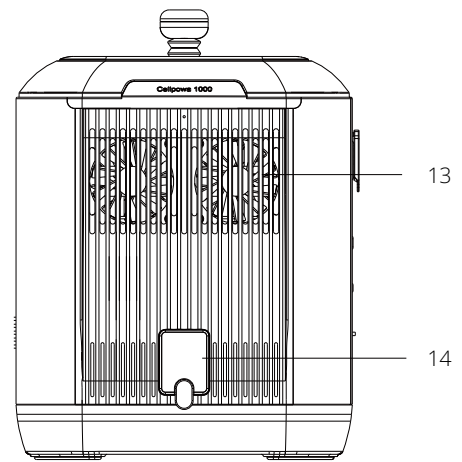

Left Panel

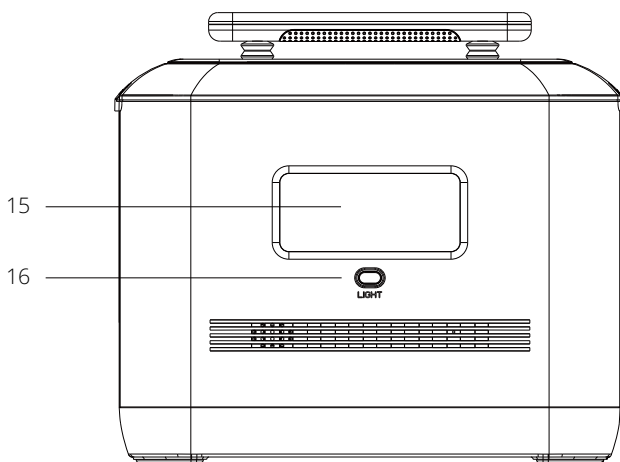

Back Panel

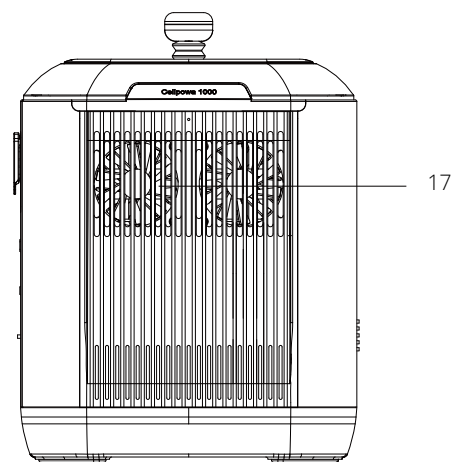

Right Panel

- |  |  |
|--|--|
| <ul style="list-style-type: none"> <li>1. Car Cigarette Lighter Socket (12V / 10A)</li> <li>2. DC 5521(2 Ports, 60W each)</li> <li>3. DC Output Button</li> <li>4. USB Type-A (2 x Fast-charging Ports, 18W each)</li> <li>5. Solar Charger (2 x DC5525 ports)</li> <li>6. Reset Button</li> <li>7. Liquid-crystal Display</li> <li>8. AC Output Ports (up to a total of 1,000W / 2,000W surgepower)</li> <li>9. Power Button</li> </ul> | <ul style="list-style-type: none"> <li>10. AC Button</li> <li>11. USB Output Button</li> <li>12. USB PD Type-C (2 Ports, 45W each) &amp; USB PD Type-C (2 Ports, 100W each)</li> <li>13. Ventilation Fan</li> <li>14. AC Recharging Input</li> <li>15. LED Light</li> <li>16. LED Light Button</li> <li>17. Ventilation Fan</li> </ul> |
|--|--|

# CONTROLS AND FUNCTIONS

## Liquid-crystal Display Indications

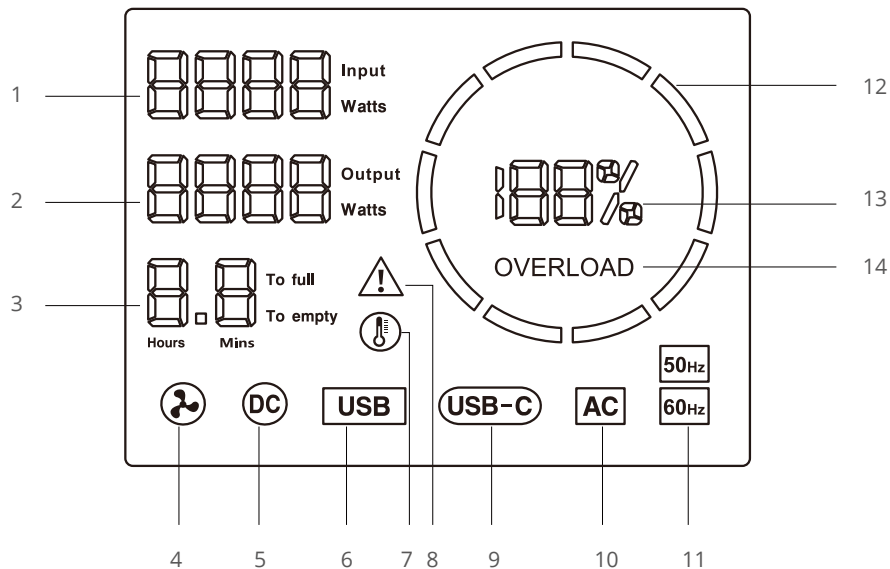

- |   |   |
|---|---|
| 1. Input Power:                             | indicates the current input power in wattage.   |
| 2. Output Power:                            | indicates the current output power in wattage.  |
| 3. Recharge Duration (hour/s) / Error Code: | indicates the duration in the hour needed for the product to be fully recharged / indicates the error code, if any (refer to page 16).  |
| 4. Ventilation Fans:                        | the icon will illuminate when the fans are operating (DC input or output exceeds 60W, AC input or output exceeds 200W or the unit temperature exceeds 131°F (55 °C)).                               |
| 5. DC Output:                               | the icon will illuminate when the DC output is charging.  |
| 6. USB Type-A:                              | the icon will illuminate when the USB Type-A is charging.   |
| 7. High-Temperature Warning:                | the icon will illuminate when the unit temperature is abnormal.   |
| 8. Alert Warning:                           | the icon will illuminate when there is a malfunction. Please stop using the unit.   |
| 9. USB Type-C:                              | the icon will illuminate when the USB Type-C is charging.   |
| 10. AC Output:                              | the icon will illuminate when the AC output is charging.  |
| 11. AC Frequency:                           | indicates the AC frequency in hertz, either 50Hz or 60Hz. To switch between the frequency values, under the AC off mode, press and hold both the 'AC ON/OFF' and 'DC ON/OFF' buttons for 4 seconds. |
| 12. Battery Status:                         | blue circular progress bar rotates when it is charged. It flashes when the battery level is near 0%.  |
| 13. Battery Level:                          | indicates the remaining power in percentage for the unit.   |
| 14. Overload Warning:                       | the text, 'OVERLOAD' will illuminate if the electrical circuit overload occurs.   |

# SYSTEM OPERATIONS

## Powering On / Off

1. Press and hold the power button for 4 seconds to power on / off the product.

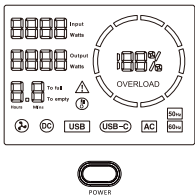

2. When the power station is connected to an AC power source, a solar panel and a car charger at the same time, the PV input is prioritized to recharge the power station.

## Power Saving Mode

1. The screen will automatically dim if no operation is conducted within 5 minutes after the product is turned on. Press any button to light up the screen again.
2. The whole product will be switched off automatically after 8 hours of the idle mode.
3. Note: Please turn off the AC output button when it is not in use to reduce the inverter power consumption.

## Recharging Mode - AC Input

1. BigBlue CellPowa 1000 is loaded with 1,075 watt-hours capacity and rated up to a maximum of 600 watts AC input.
2. Use the provided AC charging cable for the BigBlue's 'Superior Fast-charging'. Do not use other cables to recharge.
3. Plug directly into the AC wall outlet. Ensure that the wall outlet and circuit are rated for less than 15A (100~120V), or 10A (220~240V). The AC input power will appear on the LCD display when your unit is recharged via AC input, and the blue circular progress bar starts rotating.

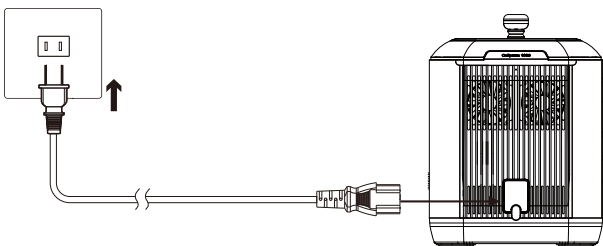



# SYSTEM OPERATIONS

## Recharging Mode - Solar Panel

1. BigBlue CellPowa 1000 supports 12 - 30V DC input / 6.2A maximum current / up to 300W.
2. Connect your CellPowa 1000 to the BigBlue SolarPowa 150 or SolarPowa 100 solar panel (sold separately), via the MC4-to-DC 5525 solar cable provided. Two solar recharging DC 5525 ports are available and you can recharge the CellPowa 1000 simultaneously.

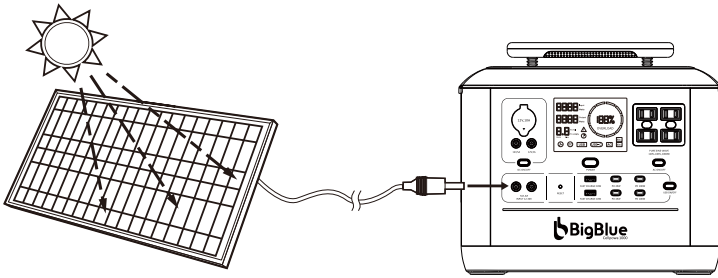

3. There is a built-in 'Maximum Power Point Tracking' (MPPT) algorithm in the CellPowa 1000. MPPT is a controller that optimizes the match between the CellPowa 1000 and the solar panels connected. It automatically detects the maximum power of the solar panel in real-time, thus being able to store up to 98% of solar generation.
4. WARNING: Do not recharge with a solar panel which open circuit voltage (VOC) is over 30V, to avoid damaging the product.

## Recharging Mode - Car Cigarette Lighter Socket

1. BigBlue CellPowa 1000 supports 12 - 24V / 5A maximum current / up to 120W.
2. NOTE: Please recharge your unit with the provided 'car charger to DC 5525' cable; and only when the car engine is operating to avoid draining your car battery.

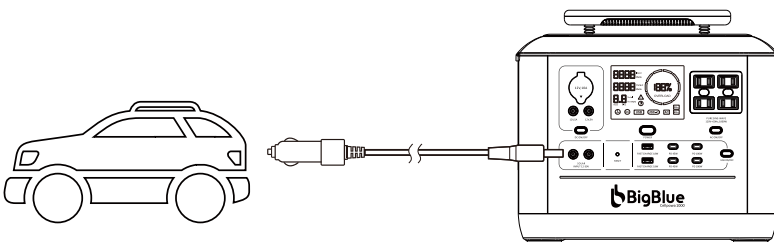

3. NOTE: Please ensure that the car cigarette lighter socket is in good condition.

# SYSTEM OPERATIONS

## Charging Mode – AC Outputs

1. BigBlue CellPowa 1000 supports up to a total of 1,000W on the pure sine wave (US: 120V / 60Hz, EU: 230V / 50Hz).

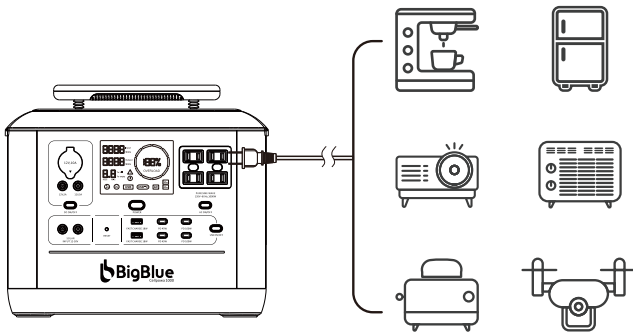

2. Please connect with the AC charging cable provided. Do not use other cables to charge.

3. Press the 'AC ON/OFF' button to activate the AC output ports.

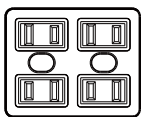

4. The icon **AC** will illuminate on the LCD display when your unit is discharging via the AC ports.

5. The AC output ports will be disabled under the circumstances below to protect against overload. The alert warning icon **⚠** will flash for one minute. Additionally, the error code will be shown on the display (refer to page 16). For safety concerns, the unit will be locked if it occurs continuously for the third time. Restart the unit to unlock.

6. NOTE: For appliances that are rated power less than 1000W, in some cases, the surge power may exceed 2,000W. At this time, the overload protection will be triggered and the AC switch will be turned off. To avoid this, do not connect your electric appliance to the unit before turning on the AC switch.

7. NOTE: When the total load power is less than 5W for 8 hours, to reduce the power discharging, the unit will be turned off automatically.

8. NOTE: When the unit is not in use, switch off the AC discharging mode by pressing the 'AC ON/OFF' button to reduce the power consumption.

# SYSTEM OPERATIONS

## Charging Mode – DC Outputs (USB Type-A, USB Type-C)

1. BigBlue CellPowa 1000 is equipped with USB Type-A (2 x fast-charging ports, 18W each), USB PD Type-C (2 ports, 45W each), and USB Type-C (2 ports, 100W each).

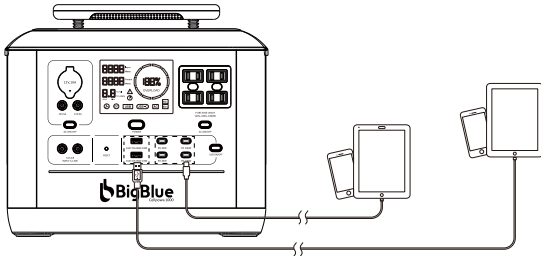

2. Press the 'USB ON/OFF' button to activate the USB ports.



3. The icon **USB** and **USB-C** will illuminate on the LCD display when the unit is charging via the USB Type-A and USB Type-C respectively.
4. For safety concerns, when the USB ports are short-circuited or overcurrent, the DC output ports will be disabled automatically and the icon will flash.
5. NOTE: When the total load power is less than 5W for 8 hours, to reduce the power discharging, the unit will be turned off automatically.
6. NOTE: When the unit is not in use, switch off the DC discharging mode by pressing the 'USB ON/OFF' button to reduce the power consumption.

## Charging Mode – DC Outputs (Car Cigarette Lighter Socket, DC 5521)

1. BigBlue CellPowa 1000 is equipped with a car cigarette lighter socket (12V / 10A), and two DC 5521 ports (12V / 5A each).
2. Press the 'DC ON/OFF' button to activate the car cigarette lighter socket and the DC 5521 ports.

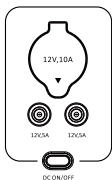

3. The icon **DC** will illuminate on the LCD display when the unit is charging via the car cigarette lighter socket and DC 5521 ports.
4. For safety concerns, when the car cigarette lighter socket and the DC 5521 are short-circuited or overcurrent, the DC output ports will be disabled automatically and the icon will flash.
5. NOTE: When the total load power is less than 5W for 8 hours, to reduce the power discharging, the unit will be turned off automatically.
6. NOTE: When the unit is not in use, switch off the DC discharging mode by pressing the 'DC ON/OFF' button to reduce the power consumption.

# SYSTEM OPERATIONS

## LED Flashlight

1. BigBlue CellPowa 1000 is equipped with a rear-mounted 4.7 inches (120 x 50mm) LED flashlight.
2. Press the 'LED Flashlight' button on the rear panel of the unit for 3 seconds, to activate the LED flashlight.

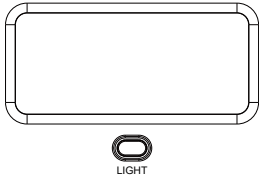

3. The LED flashlight offers tri-mode lighting; high task lighting, low moonlight, and SOS emergency mode. Press again the 'LED Flashlight' button to switch between the modes.
4. Press the 'LED Flashlight' button for 3 seconds to switch off the LED flashlight.

# SYSTEM OPERATIONS

## Utmost-B™ Charging Mode (boost-up mode)

1. BigBlue CellPowa 1000 is enhanced with the newly introduced 'Utmost-B™ Charging' mode (boost-up mode) – capability to boost up the total output to 2,000W while charging your heavy-duty devices.
2. Press and hold the 'AC ON/OFF' button for 3 seconds to activate the 'Utmost-B™ Charging' mode. The AC output button backlight will change from blue to orange color.
3. NOTE: The 'Utmost-B™ Charging' mode is not available when the AC output is turned on in recharging mode.
4. NOTE: The 'Utmost-B™ Charging' mode is suitable for heating devices. However, this mode is not applicable to all electrical appliances. It's not compatible with appliances that have strict voltage requirements with a rated power of 1000W. Please monitor the performance of the untested appliances in this mode.

## Pass-through Charging

1. BigBlue CellPowa 1000 supports 'Pass-Through Charging', allowing you to recharge the power station itself and charge the connected devices at the same time. It is very helpful if you always want your CellPowa 1000 to be at full capacity. It will prioritize the grid charging on the connected devices (bypass charging). In this case, the power of the connected appliances should not exceed 1500W(100~120V), or 1900W(220~240V). Otherwise, overload protection will be triggered and the AC output will be stopped.
2. With the pass-through charging mode, the 'Input Power' shown on the display will be the total of the input power and output power.
3. NOTE: Recommended not to use the Pass-Through Charging (charge and discharge the unit at the same time) too much.

## 10ms Uninterruptible Power Supply

1. BigBlue CellPowa 1000 is embedded with a built-in pure sine wave inverter to replenish and maintain the system in a split of 10 milliseconds when the incoming power is interrupted.
2. When the CellPowa 1000 is connected to a power grid and the incoming power is interrupted, the CellPowa 1000 is able to automatically switch to a battery-powered within 10 milliseconds.
3. WARNING: Do not connect to any electrical appliances that require zero milliseconds of switching support, to name a few data servers, continuous positive airway pressure (CPAP), etc.
4. WARNING: Connect only to electrical appliances that are less than the rated power of 1,000W to avoid overload.
5. WARNING: Please monitor the performance of the untested appliances with this feature.

# SYSTEM SPECIFICATIONS

## SPECIFICATIONS

### General Information

Net Weight (approximately)	31.97lbs/14.5kg
Dimensions	13.4 x 8.8 x 10.5 inches / 340 x 224 x 266mm
Capacity	1,075Wh
LED Light	Tri-mode: high (task lighting), low (moonlight), SOS emergency

### Output Ports

AC	Up to a total of 1,000W (2,000W surge power) / pure sine wave US: 120V / 8.33A, 60Hz EU / UK: 230V / 4.35A, 50Hz JP: 100V / 10A, 50 / 60Hz AU: 240V / 4.17A, 50Hz CN: 220V / 4.55A, 50Hz
Utmost-B™ Charging (boost-up mode)	2,000W
USB Type-A (2 x Fast-charging Ports, 18W each)	5V / 3A, 9V / 2A, 12V / 1.5A; up to 36W
USB PD Type-C (2 Ports, 45W each)	5V, 9V, 12V, 15V, 20V / 2.25A; up to 90W
USB PD Type-C (2 Ports, 100W each)	5V, 9V, 12V, 15V / 3A, 20V / 5.0A; up to 200W
DC 5521(2 Ports, 60W each)	12V / 5A; up to total 120W
Car Cigarette Lighter Socket	12V / 10A; up to 120W

### Input Ports

AC Charge	Superior fast-recharging 600W
Solar Charger (2 x DC5525 ports)	12 - 30V / 6.2A; 300W max
Car Charger	12 - 24V / 5A; 120W max

### Battery Information

Cell Chemistry	EV-grade LiFePO4
Life Cycle	3,000+ cycles (at 80% capacity charged)

### Environmental Operating Temperature

Optimal Operating Temperature	50°F - 86°F / 10°C to 30°C
Discharge Temperature	5°F - 113°F / -15°C to 45°C
Charge Temperature	32°F - 113°F / 0°C to 45°C
Storage Temperature	-4°F - 113°F / -20°C to 45°C

## FREQUENTLY ASKED QUESTIONS

### 1. What type of battery does the CellPowa 1000 portable power station use?

As ever, BigBlue has adapted the exalted electrical vehicle grade lithium iron phosphate (LiFePO<sub>4</sub>) battery. Compared to the most market-found ternary portable power stations, which use lithium-ion or lead acid; the CellPowa 1000's LiFePO<sub>4</sub> portable power station is safer as better stability at high temperatures and has a longer life span (at least 4 to 5 times longer), complementing to around 3,500+ cycles.

### 2. What appliances can be charged via the CellPowa 1000's AC output port?

Loaded with 1,075 watt-hours capacity and rated at 1,000 watts output; CellPowa 1000 is the centerpiece designed for the class-leading power station for home backup, off-grid life, and professional work. Plus, the extra feature via its 'Utmost-B™ Charging' (boost-up mode), with the capability to boost up the output to 2,000 watts when connected to heavy-duty devices.

### 3. How do I know the CellPowa 1000 is recharged?

When the CellPowa 1000 is being recharged, the blue circular progress bar will rotate.

### 4. Can I use third-party solar panels to recharge this product?

Yes. You can connect via an XT60 female connector to any solar panel, with a range of 12-30V / 5A, with maximum 300W input to recharge the CellPowa 1000 power station. Do not mix using different types of solar panels.

### 5. Can I recharge the CellPowa 1000 while supplying the power at the same time?

The CellPowa 1000 can recharge itself and supply power to the connected devices at the same time.

### 6. Why should overcharge and over-discharge be avoided?

Over-charge and over-discharge will shorten the battery's life span. It is recommended to keep the battery charged between 20% and 80%.

### 7. What is the casing of the CellPowa 1000 made of? Is it environmentally friendly?

The casing of CellPowa 1000 is made of premium and durable flame-retardant polycarbonate ABS alloy (PC-ABS with UL94 V-0 rated). It has improved strength and thermal resistance. The material is environmentally friendly.

### 8. How does the Uninterruptible Power Supply (UPS) operate?

The CellPowa 1000 portable power station supports pure sine wave Uninterruptible Power Supply (UPS) to replenish and maintain the power supply (switches from the power grid to battery supply) in a split of 10 milliseconds when the incoming power from the power grid is interrupted.

NOTE: do enable the 'AC Charging Mode' for this UPS feature.

# TROUBLESHOOTING

Error Code	Error Description	Solution
00	Inverter - Over Voltage	Check if the load meets the specifications of the unit. Reboot the unit. Contact the service team if the error still exists.
01	Inverter - Under Voltage	Check if the load meets the specifications of the unit. Reboot the unit. Contact the service team if the error still exists.
02	Inverter - Over Current	Check if the load meets the specifications of the unit. Reboot the unit. Contact the service team if the error still exists.
04	Inverter - Short Circuit	Check if the load meets the specifications of the unit. Reboot the unit. Contact the service team if the error still exists.
05	Inverter - Overload Warning	Check if the load meets the specifications of the unit. Reboot the unit. Contact the service team if the error still exists.
06	Inverter - Overload Protection (unit will be locked)	Check if the load meets the specifications of the unit. Reboot the unit. Contact the service team if the error still exists.
07	Inverter - Faulty Fuse	Check if the load meets the specifications of the unit. Reboot the unit. Contact the service team if the error still exists.
08	Inverter - Faulty Relay	Check if the load meets the specifications of the unit. Reboot the unit. Contact the service team if the error still exists.
16	Battery - Over Voltage	Reboot the unit. Contact the service team if the error still exists.
17	Battery - Over Voltage	Reboot the unit. Contact the service team if the error still exists.
18	Battery - Under Voltage	Reboot the unit. Contact the service team if the error still exists.
19	Battery - Under Voltage	Reboot the unit. Contact the service team if the error still exists.
20	Battery - Over Current	Reboot the unit. Contact the service team if the error still exists.
24	Battery - Faulty Fuse	Reboot the unit. Contact the service team if the error still exists.
25	Battery - Faulty Relay	Reboot the unit. Contact the service team if the error still exists.
40	Bypass - Over Voltage	Check if the voltage of the connected devices and the grid meet the stated specifications. Reboot the unit. Contact the service team if the error still exists.
41	Bypass - Under Voltage	Check if the voltage of the connected devices and the grid meet the stated specifications. Reboot the unit. Contact the service team if the error still exists.
42	Bypass - Over Frequency	Check if the frequency of the connected devices is set correctly. Reboot the unit. Contact the service team if the error still exists.
43	Bypass - Under Frequency	Check if the frequency of the connected devices is set correctly. Reboot the unit. Contact the service team if the error still exists.
44	Bypass - Short Circuit	Check if the load meets the specifications of the unit. Reboot the unit. Contact the service team if the error still exists.
45	Bypass - Overload Warning	Check if the load meets the specifications of the unit. Reboot the unit. Contact the service team if the error still exists.
46	Bypass - Overload Protection (unit will be locked)	Check if the load meets the specifications of the unit. Reboot the unit. Contact the service team if the error still exists.
47	Bypass - Fuse Faulty	Reboot the unit. Contact the service team if the error still exists.



# TROUBLESHOOTING

Error Code	Error Description	Solution
48	Bypass - Relay Faulty	Reboot the unit. Contact the service team if the error still exists.
88	Radiator – Over Temperature Warning	Disconnect and leave the unit few hours until reaching the recommended temperature. Reboot the unit. Contact the service team if the error still exists.
89	Radiator – Over Temperature Protection (unit will be locked)	Disconnect and leave the unit few hours until reaching the recommended temperature. Reboot the unit. Contact the service team if the error still exists.
90	Radiator – Low-Temperature Warning	Disconnect and leave the unit few hours until reaching the recommended temperature. Reboot the unit. Contact the service team if the error still exists.
91	Radiator – Low-Temperature Protection (unit will be locked)	Disconnect and leave the unit few hours until reaching the recommended temperature. Reboot the unit. Contact the service team if the error still exists.
92	The thermostatic radiator valve is not connected	Disconnect and leave the unit few hours until reaching the recommended temperature. Reboot the unit. Contact the service team if the error still exists.
93	Internal – Over Temperature Warning	Disconnect and leave the unit few hours until reaching the recommended temperature. Reboot the unit. Contact the service team if the error still exists.
94	Internal – Over Temperature Protection (unit will be locked)	Disconnect and leave the unit few hours until reaching the recommended temperature. Reboot the unit. Contact the service team if the error still exists.
95	Incorrect Voltage	Check if the load meets the specifications of the unit. Reboot the unit. Contact the service team if the error still exists.
99	Internal Faulty	Check if the load meets the specifications of the unit. Reboot the unit. Contact the service team if the error still exists.

## WARRANTY CARD

Name		Phone Number	
Email		Name Of Shop	
Model		Order Number	
UPC No.		Date Of Purchase	
Address			



[www.bigblue-tech.com](http://www.bigblue-tech.com)



[BigBlue\\_Official](#)



[BigBlue\\_Official](#)



[support@ibigblue.com](mailto:support@ibigblue.com)



[BigBlue\\_Official](#)