

# Betta® SE PLUS

## Smart Pool Skimmer

### Owner's Manual



[www.BettaBot.com](http://www.BettaBot.com)  
 888-692-3882 (888-MyBetta)  
 562-579-0001  
[info@BettaBot.com](mailto:info@BettaBot.com)

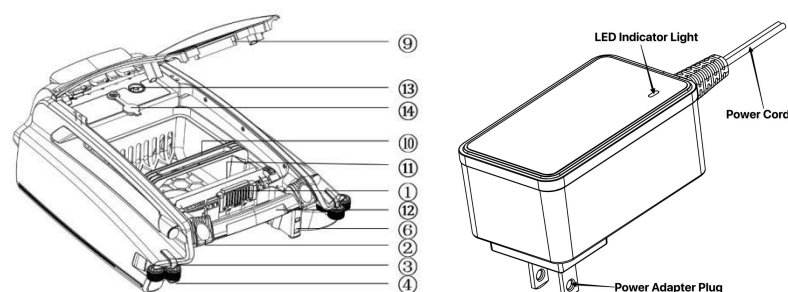

#### Parts List

1. Cover Lock
2. Distance Measure Sensor
3. LED Status Indicator
4. Guide Wheel
5. Propeller
6. Anti-stranding Bar
7. Solar Panel
8. Power Switch
9. Cover
10. Debris Collection Basket
11. Debris Intake Impeller
12. Handle
13. Charging Port
14. Charging Port Cover

## 4. Using Betta SE PLUS for the first time

### 4.1 Using for the first time

**Note: If you are charging by solar power, the unit must be turned ON. If you are charging Betta SE Plus by power adapter, the unit must be turned OFF.**

**Be sure to watch your steps and maintain your balance when working by the pool side.**

**Step 1.** Slide the power switch to the position that you can see "ON" mark to turn on the unit. LED status indicators at front will flash and then the propellers and impeller will start running.

**Step 2.** Place Betta into your pool and it will start moving and cleaning the pool's surface.

Betta runs in either Auto Mode or Remote Control Mode during operation.

#### Auto Mode

Betta is designed and programmed to be fully self-driving. It maneuvers and guides itself by reading the sensors and managing operations and charging smartly on its own. By default, the unit will be working in AUTO mode unless it's operated by the remote control.

#### Remote Control Mode

You can manually control Betta's movement and travel path in the pool using included remote control when needed. For example, if you want to Betta to go left, just press and hold the left button on the remote. Remote Mode gives you the fast control to move Betta wherever you want.



## 1. Important Safety Instructions

- DO NOT SWIM while Betta is working in the pool. Take it out of the pool and keep it at a cool place under the shade when the pool is in use.
- Betta Smart Pool Skimmer is NOT a toy. Keep it away from children.
- Be sure to watch your steps and maintain your balance when working by the pool side.
- Do not use while *other* pool cleaning devices are in the pool.
- During swimming season, keep Betta in the pool all the time unless the pool is in use or the unit needs cleaning or service.
- Do NOT leave Betta in a hot and dry spot out of the pool unattended to avoid severe damage to the unit.
- Do NOT wash Betta using pressure washer as it would cause damage to the unit.

## 2. About Betta SE Plus

Thank you for purchasing Betta the smart pool skimmer. Betta will provide you with years of reliable service when it is well taken care of and maintained properly. Be sure to read all the instructions in this manual to fully understand how to use and care for the unit.

Betta is a smart pool skimmer that mostly runs by itself. It works as a pool surface cleaner/skimmer and is powered by the solar panel or can be charged using a charging adapter that charges the battery built inside. Betta is fully self-driving unless controlled by the optional remote included. It has a control board and various sensors including a Gyro scope to guide itself while maneuvering on the pool surface. The unit picks up floating debris in its path and collects it into the removable collection basket inside. Typically, every 2-3 days, you can remove the unit from the pool and empty the collection basket and clean the unit using water hose. It goes back to the pool and starts working right away after cleaning is done.

## 3. Components

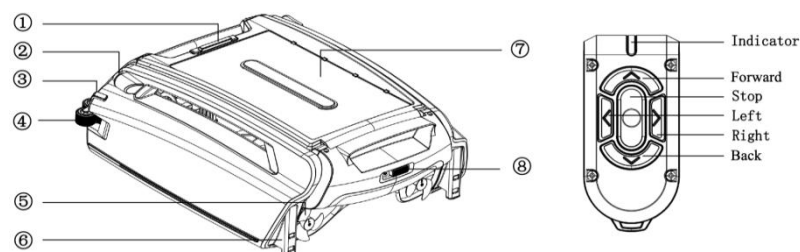

### 4.2 Remote Control

#### Pairing Betta with a New Remote

**You should be able to use the remote control out of the box since it's paired with your Betta in the factory. You only need to pair it if it doesn't work, or you replaced either the Betta unit or the remote control. See instructions for pairing below.**

Press any button on the remote control. Betta will instantly enter Remote Control Mode. Press and hold the left button to move Betta left, press and hold the right button to move Betta right, so on and so forth.

To go back to Auto Mode, press the middle button down for 2 seconds, and Betta will go back to Auto. Also, if you do not operate Betta with the remote control for 2 minutes, it will go back to Auto Mode by itself.

**Pairing:** First, slide the power to "Off" position to turn off the unit. Second, slide the switch to "ON" to turn it on. Press any button once on the remote control within 5 seconds after you turn on the unit. Test the buttons on the remote after the 5 seconds and see if the unit is moving accordingly. If yes, the pairing completes. If not, repeat this procedure from the beginning. If no success on pairing, please contact Betta customer service.

### 4.3 LED Light Status Indicator

LED light status indicators (one on each side at front) will show the operation status information of working conditions of the unit.

**Standard Mode:** lights flash in Green.

Status: there is enough power, the unit will keep running.

**Intermittent Mode:** lights flash in Red.

Status: the battery is low; the unit is running at irregular intervals in attempts to locate sunlight where it can be recharged.

**Sleep Mode:** all indicator lights are off.

Status: the battery is very low, or battery becomes completely discharged.

**Remote Mode:** lights are in steady Green.

Status: the unit is controlled manually via a remote control.

**Strand Mode:** lights flash in combination of Red and Green.

Status: the unit's propellers or impeller is not working properly, most likely it has been stuck by obstacles or cannot run freely. In this case it will stop running automatically. The unit will try to restart every 20 minutes when it is in Strand Mode.

### 4.4 Use of Anti-stranding Bumper Bars and Extended Front Bumper Rods

#### When to use:

If there are shallow stairs or other structures in your pool, Betta may be stuck on it. You can adjust the built-in anti-stranding bars to solve this problem.

#### How to use:

Press the upper button on the bar housing and pull down the bars. Each bar can be set in two positions in height. Adjust them in pairs – both front and/or both rear to keep it balanced.

**Retrieving the anti-stranding bars:** Press the down button on the bar housing and push the bar up until it's fully in position. Do it one by one.

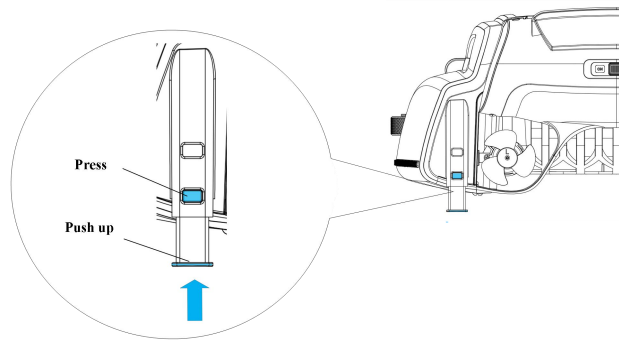

#### 4.5 Battery Run Time and Charging during Fall/Winter

During the fall/winter, the sun's rays hit the Earth at a shallow angle. These rays are more spread out, which minimizes the amount of energy that hits any given spot. Also, the long nights and short days prevent the Earth from warming up. The efficiency of solar charge will be significantly lower with a shallow angle. Thus, in those seasons, the battery may not get a full even on a sunny day. Therefore, you should expect Betta to have a shorter run time than in the summer.

**Solution 1: Use power adapter (included) to charge Betta skimmer. (see section 4.6)**  
**Solution 2: Please remove the Betta skimmer from your pool only if the weather is colder than 68 Fahrenheit (20 Celsius) degrees. Charging the unit outside of the pool by placing the unit against the wall at 45-degree angle directly facing sunlight with the power switch turned ON. Give it a full day charge and change the spots when the sun moves.**

#### 4.6 Charging by Adapter Instruction

**Note: The unit must be turned OFF when charging by power adapter.**

The charging adapter is included in the package. When the indicator light on the charger is red, it indicates that the battery is charging. When the indicator light is green, it means the battery is fully charged, and you can remove the charger.

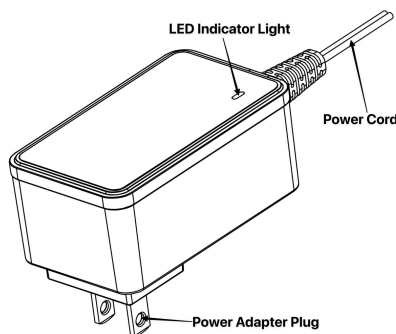

#### When to use:

When the machine's indicator light is flashing red or completely off, it needs to be charged.

#### How to use:

1. Open the charging port cover as shown below.
2. Take out charger adapter provided from the packaging box.
3. Turn the unit OFF.
4. Align the charger plug with the charging port, as shown in the diagram, and insert it.
5. Plug in the charger; the charging indicator will turn red, and the machine will begin charging.
6. When the charging indicator turns green, you can remove the charger.

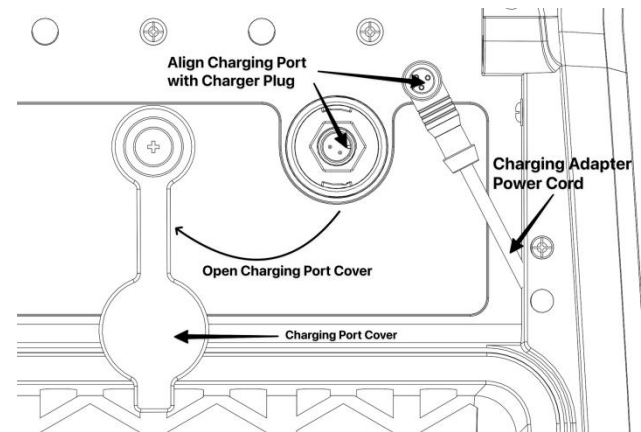

### 5. Cleaning and Storage

#### Empty Collection Basket and Cleaning

**Be sure to watch your steps and maintain your balance when working by the pool side.**

Clean the debris collection basket every 2-3 days to keep Betta running at high efficiency.

- 1) Use the remote or wait until Betta is close to the shallow end of the pool where you can have safe access to Betta.
- 2) Keep it flat when you lift it up by using two hands – one on the front handle and the other on the lift grip at the rear end to avoid debris getting out of the basket. Leave Betta on a flat surface to rest the unit.
- 3) Slide power switch off.
- 4) Unlock the cover lock. Lift the basket handle up to remove the basket out of the unit and empty the debris.
- 5) Rinse the basket out with water hose until it's completely clean.
- 6) Put the basket back in the unit, secure the cover lock, and turn power on.
- 7) While cleaning the basket, you may also clean the solar panel. You may see

some white residue on the solar panel which are chemicals and minerals from pool water. Wash the residue out using water hose and wipe clean with soft dry cloth. **Do NOT use pressure washer to clean or any tools to scrape or brush the panel to avoid damages.**

#### Winter and Long-Term Storage

If you are closing your pool for the winter, please remove Betta from the pool. Rinse Betta off with hose water, let it completely dry, and keep it indoor at room temperature in dry place away from high heat. Before the first use of the next season, check all the parts of Betta for signs of trouble before putting it back in use. Turn power on when ready to use.

### 6. Troubleshooting

**Note: Betta ONLY takes solar charge when power switch is ON, if you are charging Betta SE Plus by power adapter, the unit must be turned OFF.**

Below is some info that should help your daily use of Betta.

Problem	Possible reason	What to Do
Not running at night	The unit is in Sleep Mode. The status lights are off, indicating the battery level is very low or completely discharged.	Leave the unit in the pool. After sunrise the next day, the unit will start running in intervals in attempts to locate spots with good sunlight where it can be recharged. You may manually charge it with power charging adapter.
Not running during the daytime	Scenario 1: The unit is in Intermittent Mode – the status lights are flashing in Red, indicating the battery is low.	You may leave it as is in the pool, the unit will run in intervals in attempts to locate sunlight where it can be recharged.
	Scenario 2: The unit is in Sleep Mode. The status lights are off, indicating the battery level is very low or completely discharged.	Try to place it in the spot that has direct sunlight in the pool and wait until it gets some charge. Or you may charge it with power adapter.
	Scenario 3: The unit is in Strand Mode. Status lights are flashing in Red and Green indicating Betta is stuck at some structures, such as stairs, stools, or propeller/impeller is strapped by something.	<ul style="list-style-type: none"> <li>• Be patient and wait for a few minutes. The unit will try restarting every 20 minutes when it is in Strand Mode.</li> <li>• Ensure that the basket is in place, and the Cover Lock is properly secured.</li> <li>• Check propellers and Impeller for dirt, string, or hair.</li> </ul>
Unit only runs a short time when sunlight is sufficient	<ol style="list-style-type: none"> <li>1) The solar panel has residues.</li> <li>2) Propeller or Impeller is strapped.</li> </ol>	<ul style="list-style-type: none"> <li>• Clean the solar panels.</li> <li>• Ensure propellers and Impeller are turning freely.</li> <li>• Charge it with the power adapter.</li> </ul>

The unit is moving in circles	One or both propellers are trapped which makes the unit running unbalanced.	Check propellers and Impeller for dirt, string, and hair.
Can't be controlled by remote	If the light on remote control is not lit when press any button, remote control batteries are low.	Replace remote batteries (2x AAA).
	Remote unit is not paired with Betta.	Try pairing the remote control with Betta unit again.
	Betta may be in Sleep Mode when battery charge is extra low or completely discharged.	When sunlight becomes available, the unit will exit Sleep Mode and can then be controlled by remote.
No Battery or Short Running Time in Fall/Winter	The sunlight angle is shallow cause low solar charging efficiency. Also, the duration of sunshine is shorter.	Under certain weather condition, you may take the skimmer out of the water and put it in an angle facing the sunlight. Keep the power button always ON. See instruction is 4.5 (Battery Run time and Charging during Fall/Winter) and 4.6 (Charging by Adapter Instruction).

### 7. Warranty Information

Betta is designed to work in fresh water or salty water up to 5000 P.P.M. The unit comes with **1-Year Manufacturer's Warranty** from the date of purchase. Using the unit in sea water pools will void the warranty. If you have any issues or concerns, please contact us directly. Betta honors extended warranty ONLY through Betta Care. Any other offers from third-party retailers will not be serviced by Betta directly. If you have any questions about Betta warranty, please contact us at [info@BettaBot.com](mailto:info@BettaBot.com) or 888-692-3882.

#### Warranty Registration

scan the QR code below



[www.bettabot.com/pages/warranty-registration](http://www.bettabot.com/pages/warranty-registration)

#### Extended Warranty (Betta Care)

scan the QR code below



[www.bettabot.com/pages/warranty](http://www.bettabot.com/pages/warranty)

### 8. Customer Service

Phone: 1-888-692-3882 (1-888-MyBetta) or 562-579-0001 | Fax: 562-579-0008

Live Chat: Any webpage on [www.BettaBot.com](http://www.BettaBot.com)

Email: [info@BettaBot.com](mailto:info@BettaBot.com)