

BRAVE

OPERATOR'S MANUAL

Safety, Operation & Service Information

Pro Floor Stripper

Model: BRFPS108E

Form: GOM10081802US, Version 1.1, Original Instructions

- Do not discard this manual.
- Keep manual readily available for reference during operation or when servicing product.
- Before operation, read and comprehend operator manual content.
- When ordering replacement parts, please supply the following information: model number, serial number and part number.
- **Customer Service:** 1-800-350-8739
- **Customer Service Telefax:** 1-866-779-9963
Note: There is no charge for Customer Service.
- **Internet Address:** <http://www.braveproducts.com>
- **Email:** sales@braveproducts.com

Copyright 2020, Brave, All rights reserved.

TABLE OF CONTENTS

1 INTRODUCTION 3
2 INTENDED USE 3
3 TRAINING 3
4 SAFETY SYMBOLS..... 3
5 SAFETY INSTRUCTIONS 3
6 MACHINE SPECIFICATIONS 7
7 STANDARD PRODUCT & ACCESSORIES 7
8 MACHINE SET-UP 8
9 APPLICATION THEORY & TECHNIQUES 10
10 OPERATING INSTRUCTIONS 11
11 MAINTENANCE INSTRUCTIONS 14
12 SERVICE/REPAIR INSTRUCTIONS 15
13 TROUBLESHOOTING 16
14 STORAGE 17
15 END OF LIFECYCLE 17
16 WARRANTY 18
17 PRODUCT REGISTRATION 19
18 REPLACEMENT PARTS 20

NOTICE TO OPERATORS

IF YOU CAN NOT READ OR DO NOT FULLY UNDERSTAND THE CONTENTS OF THIS MANUAL, PLEASE CONTACT THE FACTORY FOR PROPER ASSISTANCE BEFORE ATTEMPTING TO OPERATE THIS PRODUCT.

SI TU NO PUEDES LE'ER O NO COMPRENDES EL CONTENIDO DE ESTE MANUAL FAVOR DE PONERSE EN CONTACTO CON LA FABRICA PARA ASISTENCIA-APROPIA ANTES DE INTENTAR PARA OPERAR ESTE PRODUCTO.

SOLLTEN SIE DIESE GEBRAUCHSANWEISUNG NICHT LESEN KOENNEN ODER ES NICHT VOLLKOMMEN VERSTEHEN, WENDEN SIE SICH BITTE AN DEN HERSTELLER FUER RICHTIGE HILFE EHE SIE VERSUCHEN DIESES PRODUKT ZU OPERIEREN.

SI VOUS NE LISEZ OU NE COMPRENDRE ENTIEREMENT LES MATIERES DE CE MANUEL, S'IL VOUS PLAIT, CONTACTEZ L'USINE POUR L'ASSISTANCE APPROPRIEE AVANT D'UTILISER LE PRODUIT.

IMPORTANT:

- Do not allow anyone to operate Floor Stripper without first reading this Operator Manual and becoming familiar with Floor Stripper operation.
- Manufacturer of this Floor Stripper has gone to great extremes to provide owner(s) and/or operator(s) with the finest equipment available for its intended job function of removing covering materials from concrete and wood floor surfaces. Yet, the possibility exists Floor Stripper can be utilized in and/or subjected to job applications not perceived and/or anticipated by manufacturer. Such misuse and/or misapplication of Floor Stripper can lead to possibility of serious damage, injury or even death.
- It is responsibility of owner(s) and/or operator(s) to determine Floor Stripper is utilized and/or operated within scope of its intended job function.

- It is responsibility of owner(s) and/or operator(s) to establish, monitor and constantly upgrade all safety programs and/or practices utilized in and for operation of Floor Stripper. Purpose of such programs is to provide for owner(s) and/or operator(s) safety. Operators must be instructed to recognize and avoid unsafe conditions associated with their work (29 CFR 1926.21 (b)(2)) and/or applicable updated revisions.
- It is responsibility of owner(s) and/or operator(s) to determine no modifications and/or alterations have been made to Floor Stripper. Modifications and/or alterations can lead to possibility of serious damage, injury or even death. It is responsibility of owner(s) and/or operator(s) to make this Operator Manual available for consultation during all phases of operation.
- Refer to OSHA 2207 and/or applicable updated revisions which contains all OSHA job safety and health rules and regulations (1926 and 1910) covering construction.

CAUTION

The concept of electrically powered, walk-behind floor covering removal equipment has been successfully utilized for many years as a practical solution to many types of floor covering removal requirements. The basic concept is proven and well accepted within the associated marketplaces.

Use of a Floor Stripper requires strenuous work activity. This type of work activity can be considered to be greater in magnitude than that experienced with the use of many other types of both light construction and lawn and garden related equipment. This type of work activity should only be attempted by operators of adequate physical size and stature, mental awareness, and physical strength and condition.

The body parts most noticeably affected during the floor covering removal process are the arms, hands, wrists, shoulders, lower back and legs. The covering removal process can also produce excessive stress/strain directly to the back muscles, spinal vertebrae and many other body parts. Back and wrist related pain can be side effects of using the Floor Stripper. Use of Floor Stripper may only aggravate this and any other medically related problem.

Because of the diverse type of prevailing floor removal conditions, operator experience levels and operator physical characteristics, no warranty, guarantee, representation and/or liability is made by the manufacturer as to the absolute correctness or sufficiency of any operational procedure, operational position and/or technique. There is no absolute guarantee that an operator of any given experience level, physical size and/or physical condition will be immune to the possibility of and/or probable physical side effects of the normal use of the Floor Stripper.

Each potential operator of the Floor Stripper must be made aware of and assume the operational and physical liability described and/or associated with the use of the Floor Stripper. **Each potential operator not willing to assume the operational and physical liability described and/or associated with the use of the Floor Stripper should not operate it.** Proper levels of operator experience, skill and common sense are essential for maximizing the safe and efficient operation of the Floor Stripper.

Record Floor Stripper and electric motor serial numbers in spaces provided below.

Model Number: _____

Serial Number: _____

Electric Motor Serial Number: _____

Date of Purchase: _____

Specifications and design are subject to change without notice or obligation. All specifications are general in nature and are not intended for specific application purposes. Brave reserves the right to make changes in design, engineering or specifications and to add improvements or discontinue manufacture at any time without notice or obligation. Brave and its agents accept no responsibility for variations which may be evident in actual products, specifications, pictures and descriptions contained in this publication.

OPERATOR INSTRUCTIONAL DATA SHEET

The following undersigned operators of Floor Stripper described and/or pertaining to this Operator Manual have received formal safety and operational information/instruction from undersigned owner(s)/instructor(s) in accordance to OSHA 29 CFR 1926.21 (b)(2) and/or applicable updated revisions pertaining to, but not necessarily limited to the:

1. READING, COMPREHENSION AND ACKNOWLEDGEMENT OF MATERIAL COMPRISING ENTIRE CONTENTS OF APPLICABLE OPERATOR MANUAL FOR FLOOR STRIPPER.
2. FORMALIZED OPERATOR SAFETY PROGRAM TO BE DEvised BY OWNER OF FLOOR STRIPPER IN CONJUNCTION WITH CONTENTS OF APPLICABLE OPERATOR MANUAL FOR FLOOR STRIPPER.
3. OSHA RULES AND REGULATIONS RESEARCHED FOR AND/OR BY OWNER OF FLOOR STRIPPER AND DEEMED APPLICABLE TO SAFE AND PROPER USE AND/OR OPERATION OF FLOOR STRIPPER FOR ANY SPECIFIC JOB APPLICATION.
4. LOCAL LAWS, REGULATIONS AND CUSTOMS RESEARCHED FOR AND/OR BY OWNER OF FLOOR STRIPPER AND DEEMED APPLICABLE TO SAFE AND PROPER USE AND/OR OPERATION OF FLOOR STRIPPER FOR ANY SPECIFIC JOB APPLICATION.
5. FORMALIZED MAINTENANCE PROGRAM FOR FLOOR STRIPPER TO BE DEvised BY OWNER OF FLOOR STRIPPER IN ACCORDANCE WITH, BUT NOT NECESSARILY LIMITED TO, SPECIFICATIONS, GUIDELINES AND OPERATIONAL INFORMATION CONTAINED IN APPLICABLE OPERATOR MANUAL.
6. COMPREHENSIVE OPERATIONAL INSTRUCTIONS FOR CORRECT AND PROPER USE OF FLOOR STRIPPER AS PER CONTENTS OF APPLICABLE OPERATOR MANUAL.

_____	Operator	_____	Owner/Instructor	_____	Date
_____	Operator	_____	Owner/Instructor	_____	Date
_____	Operator	_____	Owner/Instructor	_____	Date
_____	Operator	_____	Owner/Instructor	_____	Date
_____	Operator	_____	Owner/Instructor	_____	Date
_____	Operator	_____	Owner/Instructor	_____	Date
_____	Operator	_____	Owner/Instructor	_____	Date
_____	Operator	_____	Owner/Instructor	_____	Date
_____	Operator	_____	Owner/Instructor	_____	Date
_____	Operator	_____	Owner/Instructor	_____	Date
_____	Operator	_____	Owner/Instructor	_____	Date
_____	Operator	_____	Owner/Instructor	_____	Date
_____	Operator	_____	Owner/Instructor	_____	Date
_____	Operator	_____	Owner/Instructor	_____	Date
_____	Operator	_____	Owner/Instructor	_____	Date
_____	Operator	_____	Owner/Instructor	_____	Date
_____	Operator	_____	Owner/Instructor	_____	Date

NOTE: INSERT COPIES OF THIS PAGE WITHIN OPERATOR'S MANUAL IF SPACE FOR ADDITIONAL OPERATORS IS REQUIRED.

1 INTRODUCTION

Congratulations on your decision to purchase a Brave light construction product. It has been a continuing objective of Brave to provide equipment that delivers uncompromising value, service life and investment return.

When you purchased this product, you also gained access to a team of dedicated, knowledgeable, support personnel that stand willing and ready to provide field support assistance. Our team of sales representatives and in-house personnel are available to ensure each Brave product delivers the intended performance and product safety you expect. Our personnel can readily answer your questions or concerns regarding proper applications, service requirements and warranty related problems.

If you have any questions or concerns about this product, please feel free to contact our Customer Service Department during normal business hours using the contact information located on the front cover of this manual. There is no charge for this service.

Sincerely,
The Brave Team

2 INTENDED USE

The Floor Stripper is intended for use in removing VCT and linoleum tiles, soft sheet materials (PVC, rubber, linoleum, etc.), glued carpet, adhesives, mastics and material residues from dry wood and cement surfaces in a nonexplosive atmosphere. It is not intended to remove ceramic tile. The machine is operated by one adult of proper operator experience/skill/ common sense, height, weight, strength and physical condition. Minors should never be allowed to operate the Floor Stripper.

Floor Stripper is classified as a low cost, push style, low power, portable type machine. The number of practical and/or suitable job applications for this type machine is limited. Particular job application variables and operator experience, skill/common sense may require a different type machine, method and/or process to properly complete job efficiently and safely. Contact Customer Service Department for specific information regarding suitable job applications, job sites, flooring conditions and operator experience/ skill/common sense recommendations for Floor Stripper BEFORE utilization.

Never exceed the recommended capacities of the Floor Stripper. Refer to BEFORE OPERATING and SPECIFICATIONS sections in this manual for more detailed information. Always utilize the correct blades and extension cord designed for use with the Floor Stripper. Use of an incorrect blade or extension cord can result in property damage and/or personal injury.

OPERATIONAL DISCLAIMER

The manufacturer of this Floor Stripper makes no warranty or guarantee it is merchantable and/or suitable for a specific job application and that it will have the capability and power required to remove any specific floor covering from any specific work surface.

3 TRAINING

Develop a comprehensive program for safe Floor Stripper operation by owner(s) and/or operator(s). Program will include, but is not limited to: instructional operation, requirements, applicable OSHA requirements, local laws, and regulations, job site safety plus Floor Stripper maintenance. Constantly examine and upgrade program to guarantee owner(s) and/or operator(s) safety. Each operator must be fully instructed regarding specifics of this safety program.

4 SAFETY SYMBOLS

SAFETY ALERT SYMBOL & SIGNAL WORDS

The safety alert "general warning" symbol indicates a potential personal injury hazard. A signal word (DANGER, WARNING, or CAUTION) is used with the alert symbol to designate the degree or level of hazard seriousness. Other safety symbols may be used to represent the type of hazard in combination with "general warning" symbol, in highlighted boxes, or individually.

DANGER:

Indicates a hazard with a high level of risk which, if not voided, *will* result in death or serious injury.

WARNING:

Indicates a hazard with a medium level of risk which, if not avoided, *could* result in death or serious injury.

CAUTION:

Indicates a hazard with a low level of risk which, if not avoided, *could* result in minor or moderate injury.

The following safety alert symbols identify important safety messages in this manual. When you see these symbols, be alert to the possibility of personal injury and carefully read the message that follows.

SAFETY SYMBOLS & MEANINGS

Symbol	Meaning	Symbol	Meaning
	Action Required		No Trash Containers
	Read Manual		General Warning
	Wear Ear Protection		Warning, Flammable Material
	Wear Eye Protection		Warning, Explosive Material
	Wear Protective Gloves		Warning, Toxic Material
	Wear Safety Shoes		Warning, Electricity
	Wear Breathing Protection		Warning, Body Entrapment
	Disconnect From Power		Warning, Sharp Element
	No Open Flame		Warning, Floor Level Obstacle
	No Smoking		Warning, Drop Off
	No Active Mobile Phone		Warning, Slippery Surface
	No Food Or Drink		

5 SAFETY INSTRUCTIONS



- These safety instructions provide guidelines to promote safety and efficiency with the Floor Stripper.
- No warranty, guarantee or representation is made by manufacturer as to absolute correctness or sufficiency of any information or statement.
- Safety instructions are intended to deal with common practices and conditions encountered in use of Floor Stripper and are not intended to be all inclusive.
- Not following instructions in this manual can result in property damage, personal injury and/or death.



WARNING



- This product can expose you to chemicals including greases, lubrication oils, silica dusts and asbestos which are known to the State of California to cause cancer and carbon monoxide (if gasoline engine powered) which is known to cause birth defects or reproductive harm. For more information: www.P65Warnings.ca.gov.

BEFORE OPERATING



1. BEFORE operating Floor Stripper, read this manual to familiarize each operator with correct operating procedures.
2. Visually inspect Floor Stripper per MAINTENANCE INSTRUCTIONS STEPS 5 through 10 of this manual.
3. Determine Floor Stripper is in original, factory configuration and has not been modified in any manner. If questions arise about possible modifications, contact the Customer Service Department BEFORE utilization. There is no charge for this service.
4. Always start and stop Floor Stripper according to instructions to minimize possibility of unexpected or uncontrolled blade/accessory movement. Know how to stop unit in an emergency.

Physical Exertion/Body Strain

Operating Floor Stripper requires proper physical stamina, mental alertness and is strenuous. Operators must be in proper physical condition, mental health and not under the influence of any substance (drugs, alcohol, etc.) which might impair vision, dexterity or judgement. Take work breaks to maintain stamina and alertness. If you have condition(s) that might be aggravated by strenuous work, check with doctor BEFORE operating.

Vibration

Prolonged use of Floor Stripper (or other, similar machines) exposes operator to vibrations which may produce Whitefinger Disease (Raynaud's Phenomenon) reducing hand's ability to feel and regulate temperature, produce numbness, and burning sensations plus may cause circulation damage and tissue necrosis. Continuous and regular users should closely monitor condition of hands and fingers. After each period of use, exercise to restore normal blood circulation. If any symptoms appear, seek medical advice immediately.

Noise

Floor Stripper and actual floor covering removal process creates exposure to high noise emission levels that can result in hearing loss or damage. Hearing protection is required while operating or when near operating equipment. Continuous and regular operators should have their hearing checked regularly.

Clothing

Clothing must be sturdy, snug fitting, but allow complete freedom of movement. Never wear loose fitting jackets, scarves, neckties, jewelry, flared or cuffed pants or anything that could become caught on controls or moving parts. Properly secure eyeglasses, hearing aid devices and other medical related devices. Wear long pants to protect legs. Protect hands and improve grip with heavy duty, nonslip gloves. Wear and properly lace sturdy boots with nonslip soles. Steel-toed safety shoes are mandatory. Wear approved safety hard hat where there is danger of head injuries and/or approved breathing mask where danger of airborne foreign particulate contamination is present.

Flying Debris

Floor covering removal process can result in flying debris. Eye protection and appropriate safety apparel is required when near or operating Floor Stripper. DO NOT operate unit with onlookers or animals close by.

BACK CARE & PROPER LIFTING PROCEDURES

Operators will be required to lift the Floor Stripper as demanded by specific job applications. When lifting, two people are required. Utilize proper lifting techniques to minimize fatigue and back-related injuries.

Back Anatomy

The human body is supported by the spinal column consisting of thirty bones called vertebrae, all linked and supported by a series of muscles. Pads called discs separate each vertebrae, acting as cushions to pressure from external forces. Spinal column is wrapped by nerve system with three sections that require being kept in natural alignment to prevent discomfort:

- Cervical: From base of neck to brain.
- Thoracic: From middle to lower back.
- Lumbar: From lower back to buttocks area.

Back Care Preventative Measures

Most occupational physicians agree on several "universal" preventative measures an operator should follow to help lower risk of back-related injuries:

1. Maintain proper body weight.
2. Eliminate/reduce use of tobacco. Smoking reduces oxygen supply and nutrients to discs cushioning vertebrae.
3. Develop a consistent exercise routine.
4. Maintain good posture while walking or sitting.
5. Watch how you twist/bend your body while digging to prevent. Twisting/bending incorrectly can exert too much pressure on discs and vertebrae.
6. Use firm footing, keep intended path clear before carrying Floor Stripper.
7. Always use proper lifting techniques as described below.

PROPER LIFTING PROCEDURES

The following are guidelines for properly lifting the Floor Stripper are not intended to be all inclusive. Plan your path and make sure there are no obstructions or tripping hazards. Consider how you will set the load. The spinal column is a very sensitive mechanism. At any given time, improper lifting procedures can cause damage that can lead to injury.

1. Position feet a comfortable distance (shoulder width) apart to help provide necessary balance.
2. Tighten stomach muscles by pulling in your stomach. Keep back as straight as possible to keep spine, back muscles/ligaments in alignment.
3. Bend at hips and knees as much as possible.
4. Start lifting Floor Stripper by thrusting feet while lifting as much as possible with leg muscles. Use smooth movements.
5. Once Floor Stripper is lifted, keep it close as possible to the body. Avoid turning at waist. To turn, pivot entire body.
6. Keep shoulders, hips and feet pointed in same direction.

Use firm footing, keep intended path clear before carrying Floor Stripper.

TRANSPORTATION



1. When transporting Floor Stripper, remove extension cord and store. Remove accessory blade from machine and store per INSTALLING & REMOVING ACCESSORY BLADES in MACHINE SET-UP section of this manual when in following operating conditions:
 - a) To and from jobsite.
 - b) Longer distances while being repositioned on jobsite.
 - c) Traversing up and down stairways.
 - d) Performing maintenance and/or repairs.
 - e) Lifting/lowering from transportation vehicle.

DANGER

- Lifting/lowering and transporting Floor Stripper with accessory blade installed and/or improperly secured can result in property damage and/or personal injury.

WARNING

- Disconnect extension cord from Floor Stripper when traversing up and down stairs.
- Improperly stored/connected cord can entrap and/or entangle personnel.
- Such occurrence can result in property damage and/or personal injury.

2. To use personnel to lift/lower machine, use handles as shown and/or side handles near rear of unit. FIGURE 1



FIGURE 1

4. To reduce storage area and minimize damage, transport Floor Stripper in normal upright position with operator handle folded relative to main frame. Refer to MACHINE SET-UP section of this manual, FIGURE 1.
- a) DO NOT allow operator handle and main frame direct contact with each other while transporting. Provide proper protection between Floor Stripper components and vehicle.
 - b) DO NOT drop unit directly against exciter plate. Provide support block under main frame to prevent direct contact and/or damage to exciter plate and related components.
5. All equipment must be secured in/on vehicles with suitable strapping or tie downs. Personnel should not be transported in same compartment as equipment and supplies. Consult applicable OSHA regulations for specific information.



CAUTION

- An improperly secured Floor Stripper and related accessories can fall from moving vehicle and result in property damage and/or personal injury.



DANGER



- DO NOT attempt lifting/lowering Floor Stripper into/from transportation vehicle using one person only.
- Use two people or appropriate capacity power tailgate unit or hoist for such applications.
- Personnel not in proper physical/mental condition or unfamiliar in operation of lifting devices should not attempt such procedures.
- Such actions can result property damage and/or personal injury.

3. To use mechanical device to lift/lower machine, attach chain and suitable attachment device to lifting bail area behind electric motor. FIGURE 2

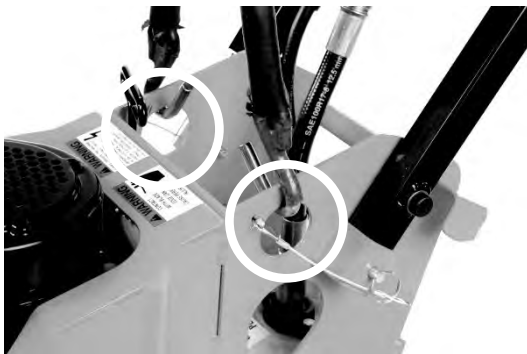

FIGURE 2

NOTE: This location may not always be the exact center of gravity for the machine.



DANGER



- Exercise extreme caution using mechanical lift devices.
- Use mechanical lift devices in accordance with their static and dynamic design envelope.
- DO NOT use mechanical lift devices until lift device operation/application guidelines are properly known and understood by all applicable personnel.
- Failure to properly use mechanical lifting device can result in property damage and/or personal injury.

DETERMINATION OF POTENTIAL SUBSURFACE HAZARDS IN PROPOSED FLOORING REMOVAL LOCATION(S)



Floor Stripper operator handle grips are constructed of non-metallic composite material and do not guarantee operators will be properly insulated from contact with charged electrical cables. Floor Stripper and related accessories are not classified as insulated.

Floor Stripper is not sealed or insulated. DO NOT operate Floor Stripper in an explosive atmosphere or near combustible materials. Refer to OSHA rules and regulations.



DANGER



- Always assume digging location contains buried underground obstructions.
- BEFORE attempting to operate Floor Stripper in proposed location(s), call 811 and/or visit www.Call811.com.
- Contact all appropriate agencies to determine exact location(s) of all buried pipelines, powerlines and material debris.
- Many utilities and other agencies will perform these tasks at minimal charge or at no cost. Have all subsurface hazards marked for easy recognition.
- Direct contact with these and other subsurface hazards can result in property damage and/or personal injury through such things as electrocution and/or explosion.



WARNING



Before attempting to operate Floor Stripper, identify/mark all potential subsurface hazards in proposed floor covering removal location(s). Potential subsurface hazards may include, but may not be limited to the following:

1. Buried debris, rotted timbers or wood planking.
2. Buried pressurized pipelines (e.g. natural gas, propane, etc.)
3. Buried electrical cables.

DETERMINATION OF POTENTIAL ABOVE SURFACE HAZARDS IN PROPOSED FLOORING REMOVAL LOCATION(S)



Normal Floor Stripper use is on level surfaces. Avoid other surface conditions which can be dangerous. Special care must be exercised on slippery, and/or difficult/uneven surfaces. Watch for cracks, high spots/other surface irregularities or drop offs to lower floor levels. Operate only when/where visibility and light are adequate for job at hand. Remove any trip/fall hazard BEFORE operating Floor Stripper. Keep proper footing and balance at all times.

WARNING

- **DO NOT operate Floor Stripper on jobsite location where forces generated during floor covering removal process can allow body parts to come in direct contact with vertical wall, foundation or other support type structures in close proximity.**
- **Such occurrence can result in property damage and/or personal injury. Always maintain a safe and reasonable distance from these type structures.**

OPERATIONAL HAZARDS



1. Floor Stripper is designed to substantially enhance machine control and reduce operator fatigue provided accessory tool does not directly contact larger, protruding obstructions (anchor bolts, pipes, nail heads, columns, openings, large cracks, utility outlets, material variances, etc., or any objects protruding from work surface). Such contact can result in rapid and jerky movement of machine and/or loss of machine control.

CAUTION

- Exercise extreme caution when operating Floor Stripper in vicinity of anchor bolts, pipes, columns, openings, large cracks, utility outlets or any object protruding from work surface.
- Contact with such objects can lead to loss of machine control, resulting in property damage and/or personal injury.

WARNING

- **Exercise extreme caution when operating Floor Stripper on above ground level floors to prevent loss of control allowing machine and/or operator to fall down to lower levels.**
- **When moving backwards during floor covering removal process, be aware of potential drop-offs and obstructions on job site.**

2. The floor covering material removal process can produce sparks, dusts and other foreign particle contamination that can result in fire and/or explosion depending on existing jobsite conditions.

WARNING

- **Sparks produced by action of accessory tool cutting blade against work surface (e.g.- striking anchor bolts) can result in fire and/or explosion depending on existing environmental conditions.**
- **This occurrence can result in property damage and/or personal injury.**

3. Many covering materials, adhesives or mastics can contain asbestos and other chemicals that are known to cause physical harm and/or affect the environment.

4. Excessive water, and/or other conductive materials on work surface can result in electrocution of operator and/or other personnel.

WARNING

- **Water and other conductive materials on work surface increases electrocution hazard potential for operator and other personnel.**
- **Determine Floor Stripper properly grounded (no faults), power cords are free of cuts, abrasions and/or exposed cable strands.**
- **Improper grounding and use of damaged power cords and/or GFI can result in property damage and/or personal injury.**
- **DO NOT expose Floor Stripper to rain or wet operating conditions.**
- **Water entering tool can increase risk of electric shock.**

Preventive Measures:

- Operator must maintain physical and mental alertness. Be prepared for unexpected blade contact with protruding anchor bolts, etc. and be capable to sense level of machine control they have.
- DO NOT operate Floor Stripper on jobsite where kickback forces can allow body parts to come in direct contact with vertical wall, foundation or other support type structures. Maintain a safe and reasonable distance from these structures.
- Maintain proper operating stance for better control of machine plus, reducing operator error and fatigue. Refer PROPER OPERATING STANCE in OPERATING INSTRUCTIONS section of this manual for more information.
- Remove water and/or conductive materials by industry-approved and/or accepted practice BEFORE removing floor covering. Determine Floor Stripper is properly grounded and extension cords are free of cuts, Abrasions and/or exposed cable strands.
- Dust and other particle contamination can be controlled by use of appropriate industrial-type dust collection system to remove/control dust and other particle contamination from work surface.

WARNING

- **Creation of dust and other foreign particle contamination from floor covering removal process can result in property damage and or personal injury.**
- **For such operating conditions, always wear NIOSH/MSHA approved dust/mist respirator and appropriate safety related apparel.**
- **Consult applicable OSHA regulations for specific information.**

WARNING

- **Always use dust collection system that meets specific job site requirements.**
- **Dust materials can meet Class II and Class III National Electric Code specifications for hazardous materials.**
- **Consideration must be given to creation of hazardous materials requiring specific disposal procedures.**
- **Determine that dust collection system is properly designed to operate within these atmospheres.**
- **Consult current National Electric Code, OSHA and EPA regulations for specific information.**

WARNING

- **Always utilize water mist spray system to operate within specific job site requirement.**
- **Dust materials can meet Class II or Class III National Electric Code specifications for hazardous materials.**
- **Consideration must be given to creation of hazardous materials requiring specific disposal procedures.**
- **Determine water mist spray system is properly designed to operate within these atmospheres.**
- **Consult current National Electric Code, OSHA and EPA regulations for specific information.**

6 MACHINE SPECIFICATIONS

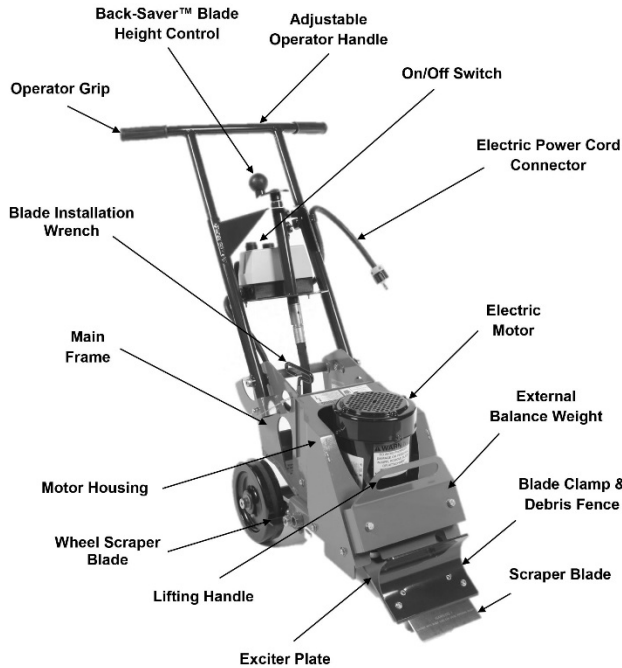

FIGURE 3

FRAME STRUCTURE	Unitized, welded steel plate.
DRIVE SYSTEM	Random orbit, direct shaft mount.
NUMBER ELASTOMERIC RUBBER MOUNTS	4
NUMBER BLADE OSCILLATIONS	1440 per minute
WIDTH	14-1/2 inches (368 mm)
OPERATOR HANDLE WIDTH	23 inches (584 mm)
TRANSPORT LENGTH	28 inches (711 mm)
OPERATING LENGTH	34 inches (864 mm)
TRANSPORT HEIGHT	23 inches (584 mm)
OPERATING HEIGHT	42 inches (1067 mm) maximum handle extension.
WEIGHT	132 lbs (59.9 Kg), with external weight, less blade.
EXTERNAL WEIGHT	14 lbs (6.3 Kg) each
ELECTRIC MOTOR	0.33 (246W), 1440 RPM, 10.3 full loaded amperes @ 115 VAC, 60 HZ, thermally protected. Motor requires clean (no other electric products on same circuit) 15 ampere capacity circuit to properly function.
EXTENSION CORDS	Minimum rating for non-manufacturer supplied extension cords SJTW 12 AWG/3C (3 x 3.31 mm ²) up to a maximum cord length of 75 feet (22.9 M).
OPERATING ENVIRONMENTS	Non-hazardous type locations.
REQUIRED NUMBER OF OPERATORS	1

NOISE & VIBRATION EMISSIONS

Description	North America	Europe
Model	BRFPS108E	
Noise Level	73 db	
Vibration Level	13 m/s ²	

FLOOR STRIPPER POWER SOURCE

The Floor Stripper is designed to operate from a clean, 15 ampere, 115 VAC, 60 Hz, nominal power source. Contact Customer Service Department for information for operation from 220 VAC, 50 Hz power source. Clean power refers to amperage available from individual electrical circuit selected.

Additional electrical products already using same circuit will reduce available amperage resulting in starting/operational difficulties. Check proper voltage and amperage levels in addition to power source being properly grounded.

Proper voltage and amperage to electric motor is essential for maximum productivity and service life. Low voltage and amperage will cause motor to overheat and can cause unreparable damage to motor and related controls. An improperly grounded circuit increases risk of electric shock. A qualified electrician may need to be consulted.

IMPORTANT: Operating Floor Stripper with improper voltage and/or amperage will result in unreparable damage to electric motor and related controls.

NOTE: Motor is equipped with automatic thermal protection, stopping motor before major internal damage occurs. If this situation occurs and motor has properly cooled, motor reset switch must be manually activated to restart.
FIGURE 4



FIGURE 4

7 STANDARD PRODUCT & ACCESSORIES

Refer to FIGURE 3 for overview description of standard components included in machine. Included in shipment for BRFPS108E Floor Stripper should be the following:

- 1 each, Model BRFPS108E Floor Stripper
- 1 each, Adjustable section of operator handle
- 1 each, 4 inch wide straight blade, part # BR16-1100
- 1 each, 10 inch wide straight blade, part # BR16-1300
- 1 each, Final inspection form

ACCESSORIES

NOTE: All blades are for use in general purpose projects on both wood and cement surfaces unless otherwise designated.

	Part #	Description	Weight (in lbs)
	BR16-1100	Blade, straight, 4 inch x 6 inch, dual bevel edged.	0.5
	BR16-1200	Blade, angled, 6 inch wide, single beveled edge. For use on cement surfaces ONLY.	2.0
	BR16-1300	Blade, straight, 3 inch x 10 inch wide, single beveled edge.	0.5
	BR16-1500	Blade, scoring, 8 inch wide, beveled edge FACING UP. For removing glued carpet, and sheet type linoleum, rubber, PVC, etc., from cement surfaces ONLY.	0.5

	BR16-1600	Blade, scoring, 8 inch wide, beveled edge FACING DOWN. For removing glued carpet, and sheet type linoleum, rubber, PVC, etc., from WOOD surfaces ONLY.	0.5
---	-----------	--	-----

8 MACHINE SET-UP



Open shipping carton immediately upon receipt. Remove Floor Stripper from carton. Visually inspect contents for freight damage and/or missing parts. If shipping damage is evident, contact delivering carrier immediately to arrange for an inspection of damage by their claims representative. DO NOT DESTROY OR DISCARD SHIPPING CARTON UNTIL INSTRUCTED BY AUTHORIZED REPRESENTATIVE OF CARRIER OR FACTORY. If missing parts are detected, notify your dealer who will assist you in obtaining them.

NOTE: If ordered with Floor Stripper, optional blades and accessories can be shipped separately or included in shipping carton.

NOTE: Floor Stripper is shipped from factory with operator handle assembly uninstalled to main frame. All lubrication fittings are lubricated at factory and will not require further servicing until first scheduled maintenance.

REMOVING FLOOR STRIPPER FROM PALLET

Tools Required:

- 1 each, cutting type pliers
- 1 each, claw hammers or hammer with appropriate pry bar

1. Using hammer, remove corrugated carton fastened to pallet.
2. Using pliers, cut banding holding machine to pallet.

! DANGER

- Wear appropriate safety glasses and other appropriate safety apparel when removing corrugated carton and cutting banding.
- Improper protection can result in property damage and/or personal injury.

INSTALLING ADJUSTABLE OPERATOR HANDLE

Installation of adjustable portion of operator handle will require a level work surface of appropriate size and height.

1. Unfold lower portion of operator handle from storage position and insert ball-detent pins through operator handle and main frame. Check ball-detent pins are inserted to fully expose ball detent and properly lock in position to prevent unexpected handle movement. FIGURE 5



FIGURE 5



WARNING

- Ball detent must be fully exposed against main frame to provide proper pin retaining force.
- An improper pin retaining configuration can result in unexpected operator handle movement.
- This occurrence can result in property damage and/or personal injury.

2. Remove threaded handle knobs from lower, fixed portion of operator handle in STEP 1. Refer to FIGURE 6.
3. Install adjustable portion of operator handles into fixed portion with adjustment slots pointing back toward operator to prevent inadvertent separation from fixed handle portion. Check handles slide freely once installed. FIGURE 6



WARNING

- Installing operator handle adjustable section with handle grips facing forward (away) from operator will not allow threaded studs to properly locate within slots provided in adjustable handle and decrease machine control and productivity.
- Slot ends form integral stops for threaded studs to thrust against.
- Proper stud/slot configuration will prevent adjustable handle from inadvertently separating from fixed section when traversing down an incline such as a stairway.
- Inadvertent separation of adjustable section can result in property damage and/or personal injury.

4. Reinstall threaded knobs, adjust handles to desired height then finger tighten knobs to secure handles firmly in place. FIGURE 6



FIGURE 6

5. To readjust handle height, loosen threaded knobs approximately 1/2 inch (13 mm), adjust handle to desired height then finger tighten knobs to secure handles firmly in place.



WARNING

- Determine threaded studs are properly seated against inside sliding portion of operator handle.
- Adjustable section must be firmly secured against fixed section of operator handle.
- Improperly secured studs can cause unstable work platform resulting in inadvertent operator handle movement and/or separation resulting in property damage and/or personal injury.

6. Inspect all fasteners for looseness. Tighten as necessary. Consult fastener torque chart for proper torque value if any fastener requires retorquing.

7. Determine all components of Floor Stripper allow for proper function as stated in this operator manual.

WARNING

- Determine all components of Floor Stripper allow for proper function and meet minimum operational standards as stated in this operator manual.
- Improper functioning components can result in property damage and/or personal injury.

INSTALLING & REMOVING ACCESSORY BLADES



Tools required:
1 each, 5/32 inch (4 mm) T-handled Allen wrench provided with machine.
1 each, blade appropriate for job application.

DANGER

- Wear appropriate safety glasses and other appropriate safety apparel when installing or removing blade on Floor Stripper.
- Improper contact with sharp edge can result in property damage and/or personal injury.

- Turn Floor Stripper ON/OFF power switch to OFF position. Disconnect extension cord of Floor Stripper from power source. Disconnect extension cord from switch box of Floor Stripper.
- Unfold operator handles from storage position and lock in place to main frame with ball-detent pins. Refer to FIGURE 5 on PAGE 8.
- Loosen knobs, fully extend adjustable portion of operator handles and retighten knobs to firmly lock in place. Refer to FIGURE 6 on PAGE 8.
- Tilt Floor Stripper back until operator handles contact floor. Apply appropriate weight to handle and chock wheels to stabilize to prevent unexpected movement and/or falling of machine. Other methods can be used to appropriately support/stabilize machine. FIGURE 7



FIGURE 7

WARNING

- Exercise extreme caution when working near or under Floor Stripper in servicing position.
- If Floor Stripper is not positioned on stable work surface or in stable configuration unexpected movement can allow Floor Stripper to fall forward relative to work surface.
- This occurrence can result in property damage and/or personal injury.

5. If existing blade is present in machine, reinstall protective edge covering (if originally supplied with blade) to prevent injury and protect blade edge.

CAUTION

- New and existing blades are extremely sharp.
- Proper handling must be taken when removing from package, installing/removing from machine, or transporting machine.
- Improper handling can result in property damage and/or personal injury.

6. Using T-handle wrench, loosen cap screws securing blade clamp. DO NOT fully remove screws or blade clamp.

CAUTION

- Use of worn and/or damaged accessory tool can result in property damage and/or personal injury.
- Consult specific accessory tool information supplied by tool manufacturer.

7. Remove existing blade and properly store. If installing new blade proceed to STEP 8 below. If no blade is to be reinstalled, proceed to STEP 9 below.

CAUTION

- Always store accessory blade with protective edge covering properly installed (if supplied with blade) to minimize effects of external damage to cutting edge and potential for property damage and/or personal injury.
- DO NOT remove protective edge covering from blade if machine is not to be used immediately.

8. Slide new accessory blade between blade clamp and exciter plate until blade contacts blade stop on back side of blade clamp. If present, DO NOT remove protective blade edge covering if machine is not used immediately. FIGURE 8 is for illustrative purposes showing blade stop on back side of blade clamp.



FIGURE 8

NOTE: Accessory blades less than 6 inches (152.4 mm) wide are centered between cap screws and may or may not have a center slot for locating/sliding around cap screw shank (if applicable). Blades wider than 6 inches (152.4 mm) provide slots that locate/slide around cap screw shanks located toward left/right sides of unit.

NOTE: Blades are provided with a protective finish. When not in use, protect and store blades appropriately to prevent rust damage.

9. Tighten cap screws using only the T-handle wrench provided/stored on machine. DO NOT use any other tool or apply impact force to screws. Wrench is designed to keep body parts a safe distance from blade edge and provide proper seating when tightening screws. FIGURE 9

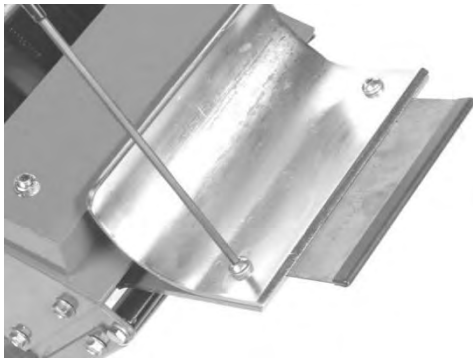

FIGURE 9

CAUTION

- Tighten/loosen cap screws with T-handled wrench provided with machine only.
- T-handled wrench was selected to keep body parts a practical distance from blade during cap screw loosening/tightening process.
- DO NOT use another type wrench/device for tightening/loosening cap screws.
- DO NOT apply any impact force to cap screws. T-handled wrench will supply ample seating torque at normal arm strength levels.
- Using incorrect wrench, and /or applying excessive impact force or torque can cause wrench to slip out of cap screw and result in property damage and/or personal injury.

CAUTION

- DO NOT substitute different fastener for factory supplied cap screw.
- Cap screw head configuration was selected for operational considerations during flooring removal.
- Use of other fastener types will reduce operational performance of machine and can result in property damage and/or personal injury.

10. Store T-handled blade wrench in storage location provided on machine. Remove any additional adjusting/tightening wrenches BEFORE operating Floor Stripper.
11. If Floor Stripper is to be placed back into service immediately, lower machine so blade rests on floor then reverse procedure in Step 1 under INSTALLING & REMOVING ACCESSORY BLADES. If not being placed back into immediate service, refer to STORAGE INSTRUCTIONS section of this manual.

9 APPLICATION THEORY & TECHNIQUES



The Floor Stripper operates on principle of accessory blades attached to an exciter plate oscillating with random orbital action to remove a variety of floor covering materials from work surfaces. Accessory blades used will affect type of materials to be removed, material removal rate(s) and resulting smoothness of work surface.

Floor covering removal process is directly controlled by:

1. Blade type, cutting edge bevel direction, angle and sharpness.
2. Sufficient machine weight and/or down force as provided by operator to accessory blade to effectively penetrate and remove floor covering material.
3. Adequate force exerted against Floor Stripper by operator to push accessory blade against floor covering material to deliver acceptable productivity rates.

4. Type, density, thickness and adhesion of adhesives, mastics, thinsets and type of floor covering material.
5. No two floor covering materials are exactly alike, no two floor covering materials can be removed by exact same method and overall operator feed rates vary. The floor covering removal process, along with operator experience, skill and common sense, suggests flooring removal is a matter of trial and error and directly determines overall success of the job application.

ACCESSORY BLADE TYPES & APPLICATIONS

Floor Stripper blades are fabricated from high carbon steel, precision machined and marked for use on either cement or wood surfaces. Blade cutting edge bevel direction is important for floor removal performance and preventing damage to flooring substrates.

NOTE: On cement surfaces, blade beveled cutting edge is positioned facing up. FIGURE 10

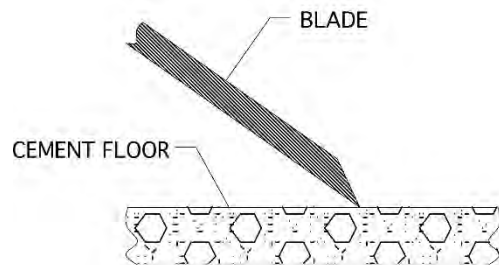

FIGURE 10

NOTE: On wood surfaces, blade beveled cutting edge is positioned facing down allowing blade to skim over versus gouging or digging into surface. FIGURE 11

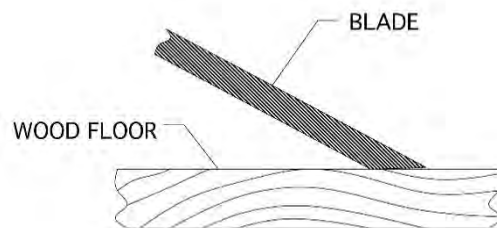

FIGURE 11

Individual accessory blade design will vary, but basic operational characteristics are identical: orbital oscillation against floor surface and remove floor covering material. This common operational characteristic through extensive testing has led to use of the following popular configurations:

Angled Mastic Removal Blade

Blade removes a wide variety of adhesives, mastics and material residues from cement surfaces only. Beveled cutting edge faces down. Refer to FIGURE 11. Use on wood surfaces will damage substrate material. The steeper blade angle increases penetration to shear and scrape materials from surface. FIGURE 12



FIGURE 12

Straight Beveled Cutting Edge Blade

Blade removes a wide variety of VCT and linoleum tiles along with general material removal from concrete and wood surfaces. Some blades feature two cutting edges. Beveled edge faces up for cement surfaces. Beveled edge faces down for wood surfaces. Specific blades are available for removing floor covering materials from either cement or wood surfaces. FIGURE 13



FIGURE 13

Straight Beveled Scoring Blades

Blade removes glued type carpet and soft sheet type (PVC, rubber, linoleum, etc.) materials from cement and wood surfaces. Cutting wings score floor covering material to aid removal. Specific part numbers are available for removing covering materials from either cement or wood surfaces. Always mount with cutting wings pointing up to prevent damage to work surface. FIGURE 14

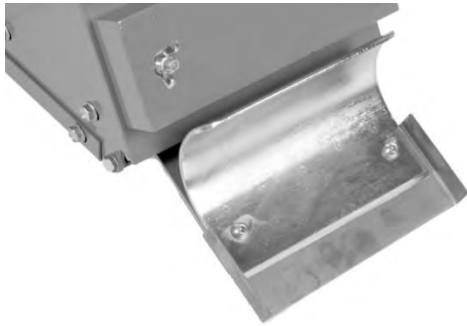

FIGURE 14

IMPORTANT: DO NOT operate straight beveled scoring blade with cutting wings pointing downward toward work surface. Damage to work surface can result.

FLOOR COVERING REMOVAL TECHNIQUES

The combination of factors makes it impossible to develop standardized Floor Stripper removal techniques and will require trial and error until satisfactory results are achieved. Experience gained over time, along with common sense, will help minimize the amount of necessary testing.

1. Specific type and/or density of adhesives, mastics and thinset materials that bond floor coverings to work surface plus variety of floor covering materials and jobsite conditions can affect removal rates. Many factors directly affect operating parameters and/or techniques utilized for special job applications.
 - a) Many adhesives/mastics remain flexible in fully cured state and are usually darker or black in color.
 - b) Adhesives/mastics that become dried and non-flexible when fully cured are usually yellowish/opaque in color and require less effort to remove than darker types.
2. Adhesive/mastic densities or thicknesses vary due to work surface application rates directly affecting bond strength. Due to these variations, accessory blade angle may need to be adjusted to optimize removal rates. As general rule the following is true:
 - a) Thinner adhesives (i.e.-amount used), require a lower accessory blade angle relative to work surface.

- b) Thicker adhesives (i.e.-amount used), require a higher accessory blade angle relative to work surface.

3. In general, for thinner adhesives (i.e.-amount used), lower shear force is required to remove and increases floor covering removal rates. The accepted procedure is to decrease effective blade width plus determine optimal blade angle relative to work surface.
4. In general, for thicker adhesives (i.e.-amount used), higher shear force is required to remove and decreases floor covering removal rates. The accepted procedure is to increase effective blade width plus determine optimal blade angle relative to work surface.
5. Higher material removal rates can sometimes be achieved by making passes 90 degrees to each other forming a waffle-like pattern. Technique is especially useful when removing deeper accumulations of rubber-like materials, material residues and dirt/debris from industrial floors.

10 OPERATING INSTRUCTIONS



IMPORTANT: DO NOT operate Floor Stripper until each operator completely comprehends contents of this manual.

CAUTION

- If Floor Stripper and/or an individual component/ accessory does not appear to function properly, STOP and DO NOT operate Floor Stripper until corrective action has been completed.
- Operation with improperly functioning machine, components/ accessories can result in property damage and/or personal injury.
- If you have any questions regarding proper operation of Floor Stripper, contact Customer Service Department for assistance BEFORE using. There is no charge for this service.

WARNING

- Floor covering removal process can produce excessive noise, vibration and flying debris.
- All operators and work personnel in Floor Stripper vicinity must wear appropriate safety eye wear and hearing protection.
- Other safety apparel and/or procedures, deemed necessary by supervisory personnel, must also be worn and/or practiced by all appropriate personnel.

CAUTION

- Individual operator experience, skill, common sense, job site location and specific job application will affect final decision on specific operating procedures for Floor Stripper.
- Each operator must decide if he possesses adequate/proper experience, skill and common sense for operating Floor Stripper in any given and/or specific job application.

FLOOR STRIPPER SET-UP ON JOBSITE

1. Position Floor Stripper on a suitable work surface.
2. Determine Floor Stripper ON/OFF switch is in OFF position and is not connected to power source.

WARNING

- Unexpected machine start-up can result in property damage and/or personal injury.

3. Raise operator handles to work position per INSTALLING ADJUSTABLE OPERATOR HANDLES in MACHINE SET-UP section of this manual.

4. Install accessory blade per procedures in INSTALLING & REMOVING ACCESSORY BLADES in MACHINE SET-UP section of this manual.
5. Adjust adjustable portion of operator handle height near waist level. Loosen threaded knobs 1/2 inch (13 mm), slide handles to desired height then finger tighten knobs to secure handles in place.
6. Connect extension cord/GFI to main power cord of Floor Stripper. FIGURE 15





FIGURE 15

 **WARNING** 

- **DO NOT modify or replace any extension cord component without utilizing a factory approved component only.**

7. Connect additional extension cord to remaining end of first extension cord (if applicable).

IMPORTANT: If additional extension cord is required, each cord must be of proper structural integrity and size (AWG) to meet applicable National Electric Code and OSHA requirements. An additional extension cord can be used in conjunction with external GFI.



 **WARNING** 

- If operating Floor Stripper in outside environment, use only extension cords marked "W-A" or "W".
- Such cords are rated for outside usage and reduce risk of electric shock.



8. Connect extension cord with GFI or additional extension cord (if applicable) to power source.

 **WARNING**



- **For maximum protection against a fault, always configure GFI to be plugged into power source receptacle.**
- **Configurations with GFI placed between Floor Stripper and power source will not provide maximum protection against potential fault.**

 **DANGER** 



- **DO NOT operate Floor Stripper without extension cord, twist-lock connection device and GFI in proper operating condition. The GFI is intended as a safety device in event power source has a fault.**
- **Always assume electrical wiring on every jobsite can contain a fault.**
- **A fault can generate a dangerous operating configuration that can result in property damage and/or personal injury.**

 **WARNING** 



- **BEFORE use, inspect each extension cord and wiring device for proper structural integrity.**
- **DO NOT use cord with or cut outer jacket material or repaired with electrical tape.**
- **Use of cords with improper structural integrity can result in property damage and/or personal injury.**

 **WARNING** 

- **All electrical wiring including extension cord gauge and/or length must be installed and/or approved in accordance with local electrical codes and practices.**
- **An improper wiring installation can result in property damage and/or personal injury.**

 **WARNING** 

- **Keep extension cord free and clear of machine and blade.**
- **In event extension cord becomes entangled about Floor Stripper and/or operator turn machine OFF immediately.**
- **Determine extension cord/GFI are in proper condition to continue operation.**
- **In event of damage, replace with factory approved component only.**

 **WARNING** 

- **DO NOT abuse the power/extension cord. Never use power/extension cord to move Floor Stripper or pull plug from receptacle. Damage to cord and GFI can result.**
- **Keep cords away from heat, oil, sharp edges (including accessory tool) or moving parts.**
- **A damaged cord increases the risk of an electric shock.**

9. Position end of accessory blade on work surface with blade edge facing away from operator.

PROPER OPERATOR STANCE (FIGURE 16):

10. Adjust adjustable portion of operator handle height near waist level.
11. Grasp handle grips firmly. Always hold operator handle firmly with both hands. Wrap fingers and thumbs around handle grips. Wear gloves to improve grip.
12. Attempt to keep wrists and forearms inline to operator handles as much as feasible. Proper wrist position during removal process can minimize and/or reduce stress and strain related damage potential to this body area, plus, operator control can be enhanced and fatigue reduced.
13. Keep upper body as vertical as possible.
14. Keep feet comfortable distance apart for stability – shoulder width, one foot in front of the other.
15. Operator must always stand behind machine when in use.



FIGURE 16

NOTE: Using improper operator stance (FIGURE 17 & 18):

- a) Reduces operator control and balance.
- b) Increases operator fatigue.
- c) Increases risk of property damage and/or personal injury.



FIGURE 17



FIGURE 18

NOTE: Proper and improper operator stances depicted in this operator manual are not all inclusive.

- 16. Grasp handle grip firmly in one hand and apply down force on handle to reduce load on blade while still in contact with work surface. Turn Floor Stripper ON/OFF switch mounted midway up operator handles to ON position with other hand. Exciter plate begins movement when motor starts. Once motor achieves operating speed remove down force on handle.

NOTE: Motor will not restart if power is lost then comes back on. Machine OFF button must be pushed first to restart.



DANGER

- **DO NOT** modify, bypass or disable Floor Stripper ON/OFF switch on operator handle.
- **DO NOT** operate machine if machine ON/OFF switch and/or red electric motor reset button is not functioning properly
- Such configuration will not allow operator to quickly stop Floor Stripper in event of an emergency, prevent unexpected machine start-up, loss of control and/or “runaway” machine and can result in property damage and/or personal injury.



DANGER

- **Always** maintain proper control of Floor Stripper.
- **Exciter plate** begins movement when motor starts. **There is no automatic motor shut off feature on machine.**
- **If operator loses control, a “runaway” machine can result in property damage and/or personal injury.**

- 17. Using proper operator stance, push forward with both hands on operator handle to begin floor covering removal process. If extension cord becomes entangled about Floor Stripper and/or operator turn machine ON/OFF switch to OFF position immediately.
- 18. As job progresses/flooring removal conditions change, without turning machine off, adjust Back-Saver™ Blade Control system on-the-fly for appropriate blade position. To operate, turn lever clockwise to decrease blade angle and counterclockwise to increase blade angle. Refer to FLOOR COVERING REMOVAL TECHNIQUES in APPLICATION THEORY & TECHNIQUE section of this manual for more information on blade angle. FIGURE 19



FIGURE 19

- 19. Floor Stripper comes with an external, front mounted weight to apply accessory blade down force. Depending on material being removed, an additional weight may be required and attached using longer carriage bolts. FIGURE 20 & FIGURE 21

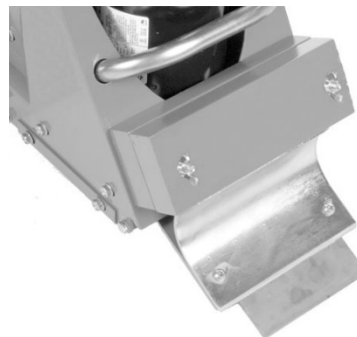



FIGURE 20



FIGURE 21



IMPORTANT: Maximum allowable number of external blocks is three or 42 lbs (19.0 kg). Exceeding maximum number of weight blocks/weight can result in permanent structural damage to Floor Stripper.

 **DANGER**

- **DO NOT** operate Floor Stripper without all external weight blocks properly secured to main frame.
- **Sudden change in movement/direction can allow unsecured weight to fall off machine.**
- **Properly secured weights are especially important when operating machine on above ground floors and work surfaces.**
- **Improperly secured weights can result in loss of machine control, property damage and/or personal injury.**

20. Consistently remove loose flooring material to determine proper material removal depths and extent of work completed. Lack of proper dust collection system and/or broom use can increase problem.

IMPORTANT: Properly dispose of all accumulated floor covering materials according to international and local environmental regulations. Floor Stripper normal use creates material build-up on machine. It is highly recommended all exposed internal/external surfaces be properly cleaned after each use plus, adjust wheel scraper clearance to minimize build-up on wheels. Refer to MAINTENANCE INSTRUCTIONS section of this manual for more information.

 **WARNING** 

- **Properly dispose of all accumulated floor covering materials per OSHA and EPA codes/regulations.**
- **Many materials can be classified as hazardous requiring proper disposal procedures.**
- **Contact applicable government agencies for specific information.**

STOPPING FLOOR STRIPPER



21. Turn Floor Stripper ON/OFF switch to OFF position between each use or when moving from one major section of work surface to another.
22. Disconnect extension cord from power source. Never leave Floor Stripper connected to power source and unattended.
23. Disconnect extension cord from machine.

 **WARNING**

- **Stop Floor Stripper when moving from one major section of work surface to another.**
- **DO NOT** choose to save time (time required to restart machine), money (if Floor Stripper is being rented) or gain added convenience by electing to keep machine running between major sections.
- **Never leave Floor Stripper running and unattended.**
- **Not doing so can result in property damage and/or personal injury.**

11 MAINTENANCE INSTRUCTIONS







For routine maintenance, the following information should be followed at minimum once per week or 40 hours of use for maximum performance and return on investment unless otherwise indicated. Information is for reference only and is not intended to be all inclusive.

1. Use factory approved replacement parts/accessories only for maintenance and repair purposes.

 **WARNING**

- **Operating Floor Stripper utilizing components not meeting minimum operational standards can result in property damage and/or personal injury.**

2. All maintenance/repairs not described in this operator manual must be done by a dedicated service center following a specific service/repair manual.
3. STOP Floor Stripper BEFORE performing maintenance per STOPPING FLOOR STRIPPER in OPERATING INSTRUCTIONS section of this manual.







 **WARNING**   

- **Disconnect Floor Stripper extension cord from power source and machine before performing any service work or repair.**
- **Failure to properly disconnect Floor Stripper from power source can result in property damage and/or personal injury.**

4. Remove accessory blade per INSTALLING & REMOVING ACCESSORY BLADE in MACHINE SET-UP section of this manual.
5. Inspect for loose or broken parts. Inspect each blade for sharpness and cracking. Inspect all fasteners, individual parts, operator controls and safety devices for proper function. Tighten fasteners as necessary. Replace any worn or damaged part or assembly.
6. Remove all loose material accumulations, dirt and grease on internal/external surfaces to prevent safety hazards, poor performance and reduced service life. Use proper dust collection system as necessary to remove most accumulation then use safety type solvent for final Floor Stripper cleaning. Failure to clean Floor Stripper can result in formation of dried material build-up reducing bearing service life and increase vibration levels felt by operator during operation.

NOTE: Electric motor is fully enclosed, fan cooled design (TEFC). Keep fan fins clear of material accumulations for proper air flow/cooling.

IMPORTANT: DO NOT use thinner, benzene, or other volatile solvents that can attack rubber/plastic components when cleaning Floor Stripper.

 **DANGER**     

- **Use safety type solvent.**
- **Provide adequate ventilation.**
- **DO NOT** smoke while using cleaning solvents.
- **DO NOT** use solvents with motor running or if it is hot.
- **Allow ample time for motor to cool BEFORE** using solvents.
- **An ignition source in close proximity to hot motor can be source of an explosion, resulting in property damage and/or personal injury.**

WARNING

- Properly dispose of all accumulated floor covering materials per OSHA and EPA codes/regulations.
- Many materials can be classified as hazardous requiring proper disposal procedures.
- Contact applicable government agencies for specific information.

7. Inspect Floor Stripper ON/OFF and red, electric motor reset switch for proper function. If damaged or worn, replace.
8. Inspect operator handle grips for moisture, pitch, oil or grease and are not cracked, damaged or worn. If full of dirt or pitch, clean. If loose, damaged and/or worn or end caps are missing, replace.
9. Inspect operator handle for structural integrity, cracks or abrasions.
10. Inspect all safety and operation decals for proper condition. If any decal becomes damaged and/or unreadable, replace.

12 SERVICE/REPAIR INSTRUCTIONS



The following information is intended for specific service/repair situations for the Floor Stripper. Information is for reference only and is not intended to be all inclusive.

1. Use factory approved replacement parts/accessories only for servicing/repair purposes.

WARNING

- Operating Floor Stripper utilizing components not meeting minimum operational standards can result in property damage and/or personal injury.

2. All service/repairs not described in this manual must be done by a dedicated service center following a specific service/repair manual. DO NOT service/repair Floor Stripper unless designated service/repair technician has received adequate, professional instruction regarding proper procedures.
3. STOP Floor Stripper BEFORE performing service and repair per STOPPING FLOOR STRIPPER in OPERATING INSTRUCTIONS section of Operator's Manual.

WARNING

- Disconnect Floor Stripper extension cord from power source before performing any service work or repair.
- Failure to properly disconnect Floor Stripper from power source can result in property damage and/or personal injury.

4. Remove accessory blade per INSTALLING & REMOVING ACCESSORY BLADES in MACHINE SET-UP section of Operator Manual and inspect for sharpness and cracking. Sharpen blade per ACCESSORY BLADE SHARPENING in SERVICE/REPAIR INSTRUCTIONS section of this manual. Replace blade if severely worn or damaged.
5. Visually inspect Floor Stripper per MAINTENANCE INSTRUCTIONS STEPS 5 through 10 of this manual.

IMPORTANT: DO NOT use thinner, benzene, or other volatile solvents that can attack rubber/plastic components when cleaning Floor Stripper.

DANGER

- Use safety type solvent.
- Provide adequate ventilation.
- DO NOT smoke while using cleaning solvents.
- DO NOT use solvents with motor running or if it is hot.
- Allow ample time for motor to cool BEFORE using solvents.
- An ignition source in close proximity to hot motor can be source of an explosion, resulting in property damage and/or personal injury.

WARNING

- Properly dispose of all accumulated floor covering materials per OSHA and EPA codes/regulations.
- Many materials can be classified as hazardous requiring proper disposal procedures.
- Contact applicable government agencies for specific information.

LUBRICATION

Grease intervals will vary dependent on machine use and operating environments. In general, lubrication should be performed after every 8 hours of continuous use.

Tools Required:
1 each, standard grease gun

Lubricants Required:
1 each, (for standard grease gun) fill with one of the following:
a) ESSO Beacon 325
b) Shell Alvana #2
c) Chevron SRI or equivalent
1 each, container dry film lubricant

1. Lubricate caster wheel bearings using dry film lubricant. Lubricant dries immediately.

IMPORTANT: DO NOT lubricate caster wheel bearings with other than dry film type lubricants or over lubricate to prevent foreign material attraction and reduced bearing service life. Use sparingly.

2. Zerk type fittings are provided at two locations. Using grease gun, lubricate pivot plate bushings.
 - a) Lubricate Back-Saver™ Blade Control system jackscrew to minimize blade control friction during operation. FIGURE 22



FIGURE 22

- b) Lubricate exciter plate shielded bearing and bearing housing casting. Zerk fitting lubricates bearing balls and self-aligning feature of bearing. FIGURE 23

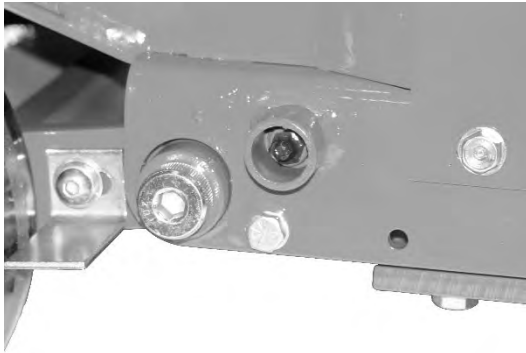

FIGURE 23

IMPORTANT: DO NOT over lubricate to prevent foreign material accumulations and accelerated wear/reduced bearing service life. Grease accumulation on bearing/bearing housing indicates excessive lubrication.

NOTE: Sleeve bearings for operator handle are self-lubricating plus ball bearings are shielded or sealed. Both will not require lubrication during normal service life.

ACCESSORY BLADE SHARPENING

1. Blades can be sharpened using a file designed for use on metal materials. This method will not duplicate original blade sharpening process, but can significantly increase overall productivity rates versus use of a dull blade.

- a) Remove blade from Floor Stripper per INSTALLING & REMOVING ACCESSORY BLADES in MACHINE SET-UP section of this manual.
- b) Properly secure blade in suitable vice.
- c) Use file to sharpen blade edge using similar method to sharpening rotary lawnmower blade. FIGURE 24



FIGURE 24

WARNING	
<ul style="list-style-type: none"> • Exercise extreme caution sharpening accessory tools. • Properly secure accessory blade when sharpening. • Remain clear of cutting edge when sharpening. Observe all safety precautions. • Improper contact with cutting edge can result in property damage and/or personal injury. 	

ELECTRIC MOTOR SERVICE

The motor is designed for long service life with minimal maintenance. The motor is equipped with higher capacity ball bearings and seals intended for dust-filled atmospheres that should not require lubrication for many years.

- 1. If bearing lubrication or seal replacement is necessary, contact local motor manufacturer representative for specific information.

13 TROUBLESHOOTING

NOTE: If troubleshooting information does not correct situation, all maintenance/repairs not described in this operator manual must be done by a dedicated service center following a specific service/repair manual.

MOTOR WILL NOT START OR LOSES POWER

Possible Cause	Correction
ON/OFF switch located on operator handle in OFF position.	Turn to ON position.
Thermal protection switch activated.	Allow motor to cool. Push red button on motor to reset.
Operator handle cord plug to electric breaker not connected.	Inspect for damage and proper connection configuration. Connect cord to extension cord.
No power received from power source.	Consult qualified electrician for proper voltage and ampere output.
Improper extension cord connection (if applicable).	Determine all connections produce a closed circuit. Reduce length and/or increase cord cross-sectional size.
Motor loses power.	Check power source for correct voltage and amperage.
High operating temperatures.	Disconnect machine from power source. Allow to cool. Determine motor fan blades are clean of foreign material accumulations. Clean as necessary using appropriate solvent.

ACCELERATED EXCITER SHAFT BEARING WEAR AND/OR FAILURE

Possible Cause	Correction
Retaining clamp screws loose.	Clean blade clamp area, retighten screws.
Worn or damaged accessory blade.	Replace blade.
Worn or damaged elastomeric mounts.	Replace mounts.

DIFFICULTY OPERATING BACK SAVER™ BLADE CONTROL SYSTEM

Possible Cause	Correction
Misaligned jackscrew bearing.	Loosen and realign.
Bent jackscrew.	Replace jackscrew and flexible joint assembly.

UNEVEN ACCESSORY BLADE WEAR

Possible Cause	Correction
Incorrect blade installation.	See INSTALLING & REMOVING ACCESSORY BLADES this manual.
Damaged exciter plate.	Replace plate.
Damaged elastomeric rubber mount(s).	Replace mounts.
Bent blade.	Replace blade.

EXCESSIVE JUMPING ON WORK SURFACE

Possible Cause	Correction
Incorrect blade installation.	See INSTALLING & REMOVING ACCESSORY BLADES this manual.
Improper blade angle.	Readjust blade angle.

UNEVEN FLOOR COVERING MATERIAL REMOVAL

Possible Cause	Correction
Blade beveled edge orientation incorrect for type work surface.	Change orientation. Refer to ACCESSORY BLADE TYPES & APPLICATIONS section this manual.
Bent accessory blade.	Replace blade.
Excessive material build-up on caster wheel face surface.	Remove material. Readjust wheel scraper to wheel gap setting: .03/.06 inch (0.8/1.5 mm).
Excessive axle shoulder-type cap screw wear.	Replace cap screw.

14 STORAGE

LONG TERM STORAGE



Procedure for long term storage of Floor Stripper will protect it against effects of corrosion and damage. If Floor Stripper is not to be operated for a period of 30 days or more, proceed to store as follows:

1. STOP Floor Stripper per STOPPING FLOOR STRIPPER in OPERATING INSTRUCTIONS section of this manual.
2. Remove accessory blade per INSTALLING & REMOVING ACCESSORY BLADES in MACHINE SET-UP section of this manual. Store to prevent damage or rust.



CAUTION



- DO NOT store Floor Stripper accessory blade attached. This configuration can result in property damage and/or personal injury.

3. Clean Floor Stripper per MAINTENANCE INSTRUCTIONS section of this manual.
4. Inspect all visible parts for wear, breakage or damage per MAINTENANCE INSTRUCTIONS section of this manual.
5. Apply a dry film lubricant to all exposed metal components, including accessory blade, to prevent rust formation.
6. Block bottom of main frame to prevent damage to exciter plate and elastomeric rubber mounts.
7. Store Floor Stripper inside. If Floor Stripper must be stored outside, protect it with a suitable covering.

15 END OF LIFECYCLE



If the machine comes to the end of its lifecycle, destruction of the machine must be conducted according to international and local environmental regulations.



20195 South Diamond Lake Road, Suite 100 • Rogers, MN 55374
Toll-Free: 800-350-8739 • Website: braveproducts.com • Email: sales@braveproducts.com

Dear Valued Customer:

The Brave product you just purchased is built with the finest material and craftsmanship. Use this product properly and enjoy the benefits from its high performance. By purchasing a Brave product, you show a desire for quality and durability. Like all mechanical equipment this unit requires a due amount of care. Treat this unit like the high-quality piece of machinery it is. Neglect and improper handling may impair its performance.

Thoroughly read the instructions and understand the operation before using your product. Always contact Brave Product Support at 1-800-350-8739 prior to having any service or warranty work performed, as some services performed by parties other than Brave approved service centers may void this warranty. This limited warranty is in lieu of any other warranty expressed or implied, written or oral and Brave assumes no other responsibility or liability outside that expressed within this limited warranty.

Limited Warranty for Brave and Brave Pro Floor Strippers:

BRPFS105E BRPFS108E

	Consumer Warranty Period	Commercial Warranty Period
Weldments	2 years from date of purchase by user	2 year from date of purchase by user
Gear Case	2 years from date of purchase by user	1 year from date of purchase by user
Wear Parts	In addition to the normal warranty, Brave shall warrant some normal wear items from defects in material or workmanship for a period of 30 days from the date of purchase by user. Normal wear items covered under this warranty are, but not limited to: High impact wear related components such as V-belts, flails, flail rods and flail drums. High abrasion wear related parts such as augers, auger fighting, boring heads, multi-accessory attachments, tungsten carbide inserts and flexible ducts. Engine throttle control cable assemblies and related control devices. Centrifugal clutch components such as shoes, springs drum and rotor assembly. Routine maintenance items such as lubricants, clutch adjustments, tune ups are not covered under warranty.	
Engines, Motors, Pumps and Controls	The warranty of these main components and engine is covered under the terms and conditions as outlined by the component and engine manufactures warranty contained herein and is the sole responsibility of the component and engine manufacturer. Normal engine maintenance such as spark plugs, oil changes, air filters, adjustments, fuel system cleaning and obstruction due to build up is not covered by this Brave limited warranty.	

“Consumer use” means personal residential household use by a consumer. “Commercial use” means all other uses, including, but not limited to, use for commercial, income producing or rental purposes or when purchased by a business.

This limited warranty applies to the original purchaser of the equipment (verification of purchase, in the form of a receipt, is the responsibility of the buyer), is non-transferable, and covers parts and labor. Parts will be replaced or repaired at no charge, except when the equipment has failed due to lack of proper maintenance. If a part is no longer available, the part may be replaced with a similar part of equal function. Any misuse, abuse, alteration or improper installation or operations will void warranty. Determining whether a part is to be replaced or repaired is the sole decision of Brave. Brave will not provide for replacement of complete products due to defective parts. Any costs incurred due to replacement or repair of items outside of a Brave approved facility is the responsibility of the buyer and not covered under warranty. Transportation costs to and from service center and/or service calls are the responsibility of the customer.

This limited warranty specifically excludes the following: failure of parts due to damage caused by accident, fire, flood, windstorm, acts of God, applications not approved by Brave in writing, corrosion caused by chemicals, use of replacement parts which do not conform to manufacturer’s specifications, damage related to rodent and/or insect infestation and damage caused by vandalism. Additional exclusions: loss of running time, inconvenience, loss of income, or loss of use, including any implied warranty of merchantability of fitness for a specific use. Also, outdoor power equipment needs periodic parts and service to perform well, and this limited warranty does not cover instances when normal use has exhausted the life of a component or the engine.

This limited warranty does not cover any personal injury or damage to surrounding property caused by failure of any part, misuse or inability to use the product. Alteration of the product, including safety features, shall void this limited warranty.

Repair or replacement of parts does not extend the warranty period. This limited warranty gives you specific legal rights. You may also have other rights that vary by state. Please have model number, item number and serial number on hand prior to making a warranty claim or inquiry.

For products purchased on or after February 1, 2015

Rev. 07/18



**Brave
Product Registration Form**

YOUR INFORMATION

Full Name:

Last First M.I.

Address:

Street Address Apartment/Unit #

City State ZIP Code

Home Phone:

Alternate
Phone:

Email

PURCHASED FROM

Company:

Address:

Street Address Apartment/Unit #

City State ZIP Code

MODEL INFORMATION

Purchase Date

Application Type

- Homeowner Commercial Rental

Model (i.e. BRP240HHD)

Serial # (i.e. 123456)

Signature

Register your product online at www.braveproducts.com

Replacement Parts Diagram BRPFS108E Pro Floor Stripper

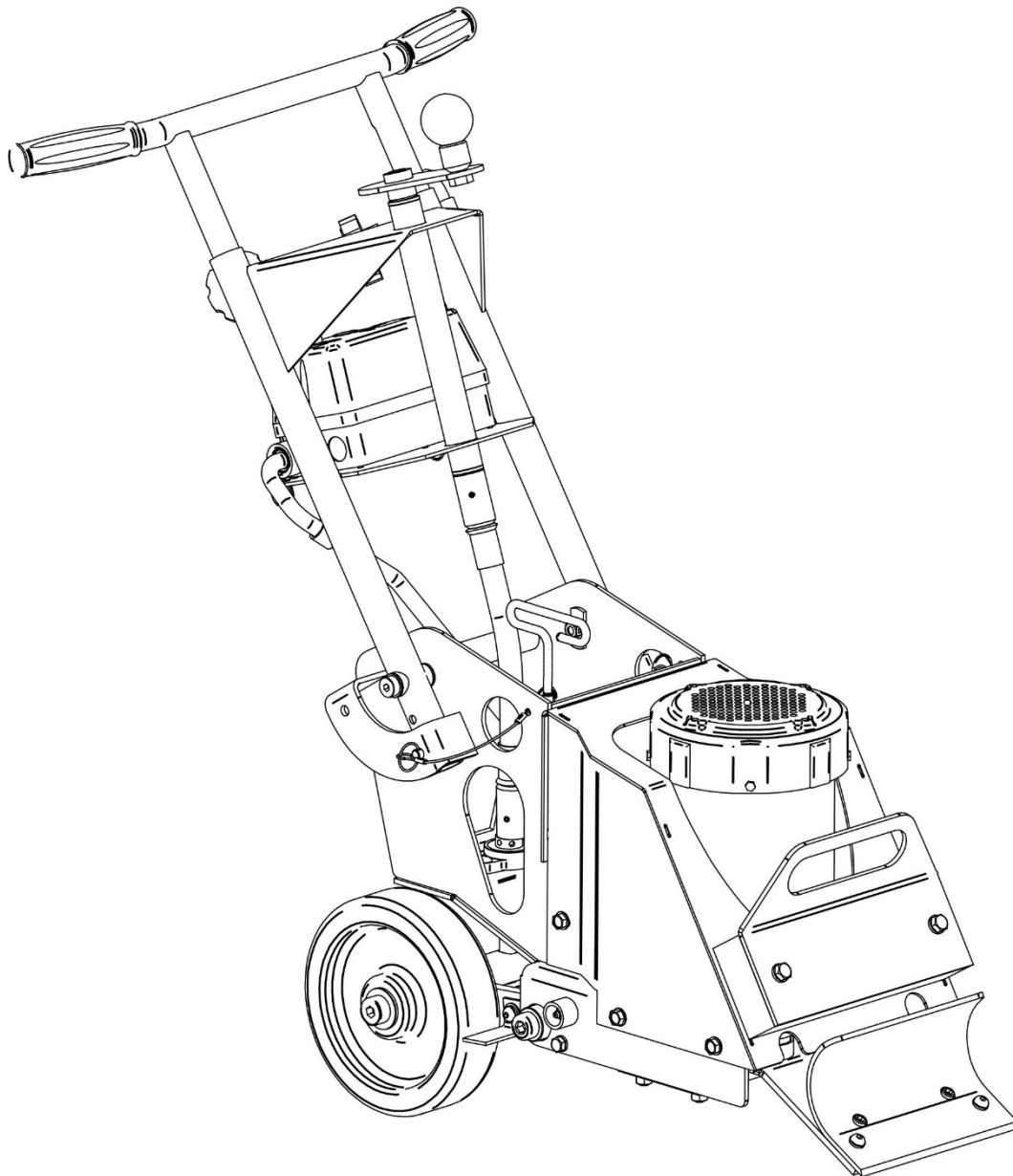

Replacement Parts Diagram Handle Assembly BRPFS108E Pro Floor Stripper

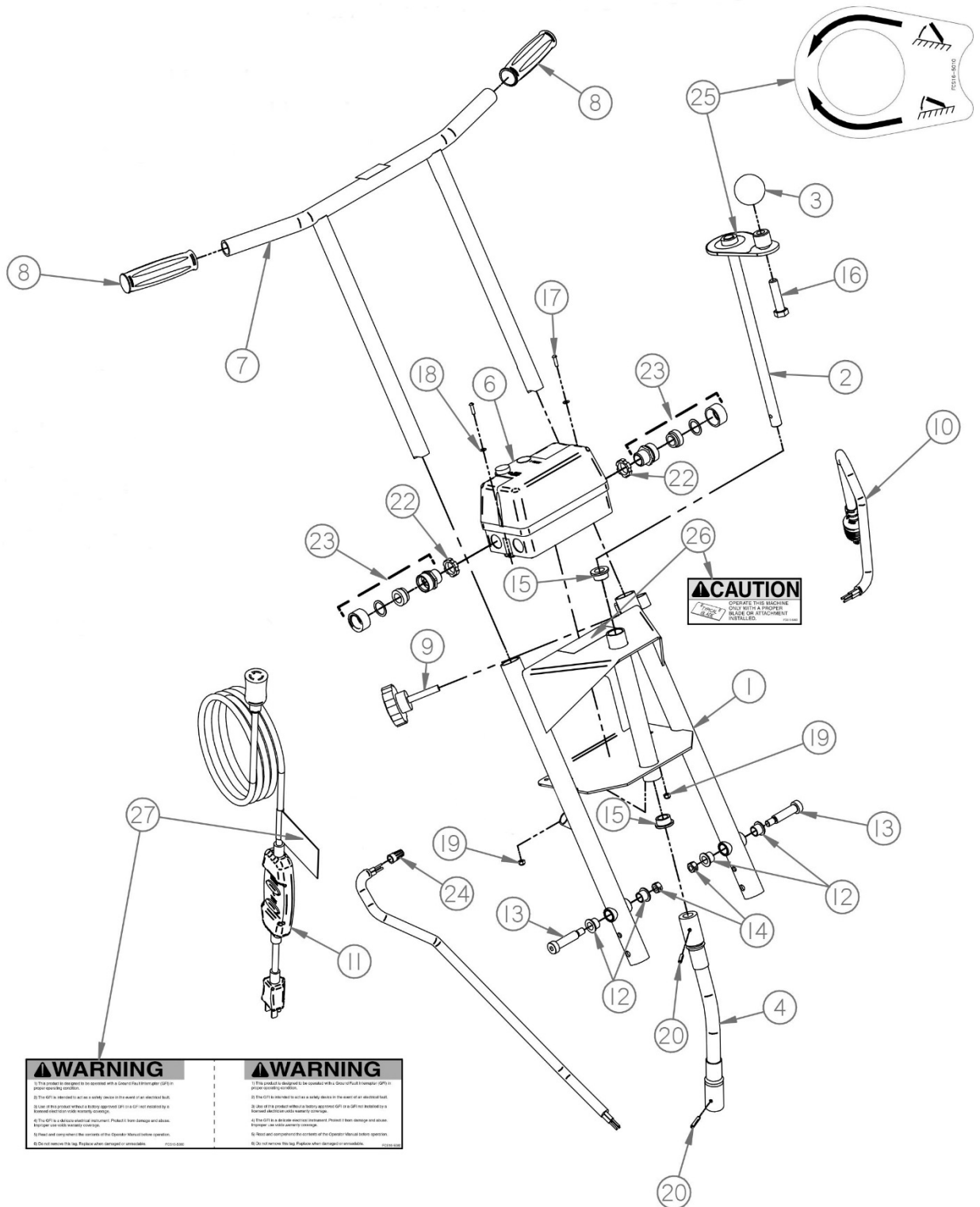

*Replacement Parts Diagram
Handle Assembly
BRPFS108E Pro Floor Stripper*

Reference Number	Part Number	Description	Quantity
1	FCS16-0181	Handle, Lower	1
2	FCS16-0141	Weldment, Crank	1
3	SP8-0120	Knob, Handle	1
4	FCS16-0120	Assembly, Hose	1
6	FCS16-0462	Starter, Magnetic	1
7	FCS16-0161	Handle, Top	1
8	FCS16-0290	Grip, Handle	2
9	FCS16-0150	Knob, Adjustment	2
10	FCS16-0042	Cable, Plug To Switch, Molded	1
11	FCS16-1000A	Cord, Extension, GFCI	1
12	FCS16-0340	Bearing, Oilite	4
13	62081400	Bolt, Shoulder, 1/2 X 1-3/4	2
14	52060000	Nut, Lock, 2-Way, 3/8-16, ZY	2
15	FCS16-0400	Bearing, Oilite	2
16	15081600	HHCS, 1/2-13 X 2, ZY	1
17	34020500	RHSMS, #8-32 X 5/8, Z	2
18	17020000	Washer, Flat, #8, SS	2
19	53020000	Nut, Nylok, #8-32, ZY	2
20	20030900	Pin, Roll, 3/16 X 1-1/8	2
22	801	Nut, Bulkhead	2
23	CG-5050	Relief, Strain	2
24	WIRENUTY	Nut, Wire	1
25	FCS16-5010	Decal, Adjustment, Angle	1
26	FCS10-5060	Decal, Use Blade	1
27	FCS16-5080	Decal, Cord, GFCI	1

Replacement Parts Diagram Frame Assembly BRPFS108E Pro Floor Stripper

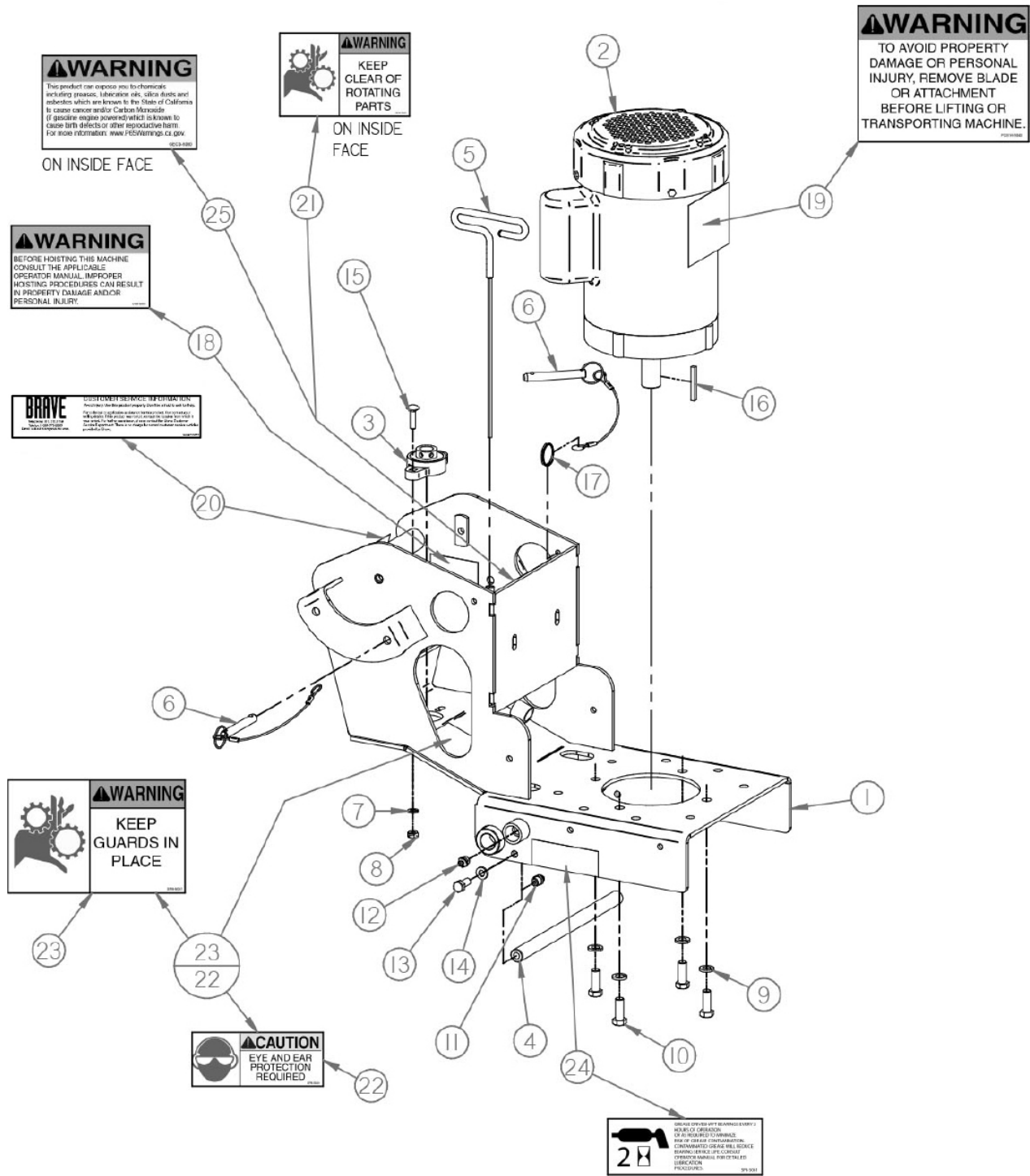

*Replacement Parts Diagram
 Frame Assembly
 BRPFS108E Pro Floor Stripper*

Reference Number	Part Number	Description	Quantity
1	FCS16-0012	Frame, Main	1
2	FCS16-0031	Motor, Electric, Shaft, .87D	1
3	SP8-0430CP	Bearing, Flange	1
4	FCS16-0220	Bar, Stop	1
5	FCS16-0260	Wrench, Hex, T-Handle	1
6	FCS16-0210	Assembly, Pin W/Lanyard	2
7	16040000	Washer, Lock, 1/4, ZY	2
8	18040000	Nut, Hex, 1/4-20, ZY	2
9	16060000	Washer, Lock, 3/8, ZY	4
10	15060800	HHCS, 3/8-16 X 1, ZY	4
11	SG12-0120	Connector, Grease	1
12	SP8-0590	Fitting, Grease, Straight	1
13	15050600	HHCS, 5/16-18 X 3/4, ZY	2
14	16050000	Washer, Lock, 5/16, ZY	2
15	87040800	Bolt, CRG, 1/4-20, 1, ZY	2
16	63031300	Key, Square, 3/16 X 1-5/8	1
17	KIC-172	Ring, Kickout	2
18	CS8-5051	Decal, Warning, Hoisting	1
19	FCS16-5040	Decal, Warning, Blade Removal	1
20	SG24-5072	Decal, Assistance	1
21	SP8-5031	Decal, Warning, Clear Rotating	1
22	SP8-5041	Decal, Caution, Eye/Ear	1
23	SP8-5051	Decal, Warning, Guards	1
24	SP8-5061	Decal, Procedures, Grease	1
25	GECD-5060	Decal, Warning, Prop 65	1

Replacement Parts Diagram Motor Cover Assembly BRPFS108E Pro Floor Stripper

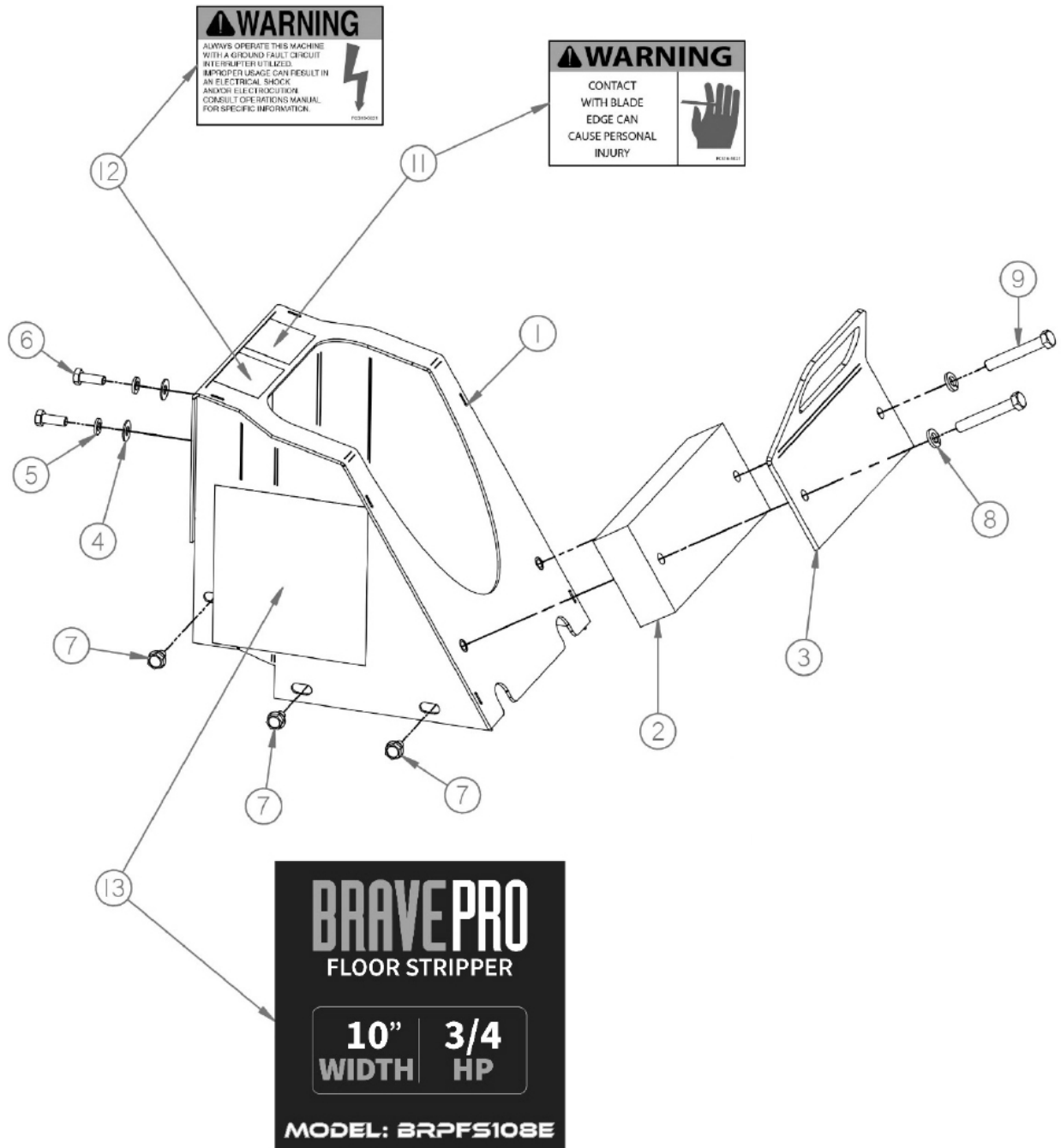

*Replacement Parts Diagram
 Motor Cover Assembly
 BRPFS108E Pro Floor Stripper*

Reference Number	Part Number	Description	Quantity
1	FCS16-0171	Cover, Motor	1
2	FCS16-0231	Weight, External	1
3	FCS16-0201	Handle, Front	1
4	17040000	Washer, Flat, 1/4, ZY	2
5	16050000	Washer, Lock, 5/16, ZY	2
6	15050700	HHCS, 5/16-18 X 7/8, ZY	2
7	48050400	Screw, Drive, 5/16-18 X 1/2, Z	6
8	16060000	Washer, Lock, 3/8, ZY	2
9	15062000	HHCS, 3/8-16 X 2-1/2, ZY	2
11	FCS16-5021	Decal, Warning, Blade	1
12	FCS16-5031	Decal, Warning, Shock	1
13	ZDBRPFS108E	Decal, Brave Pro Floor Stripper	2

Replacement Parts Diagram Adjustable Axle Assembly BRPFS108E Pro Floor Stripper

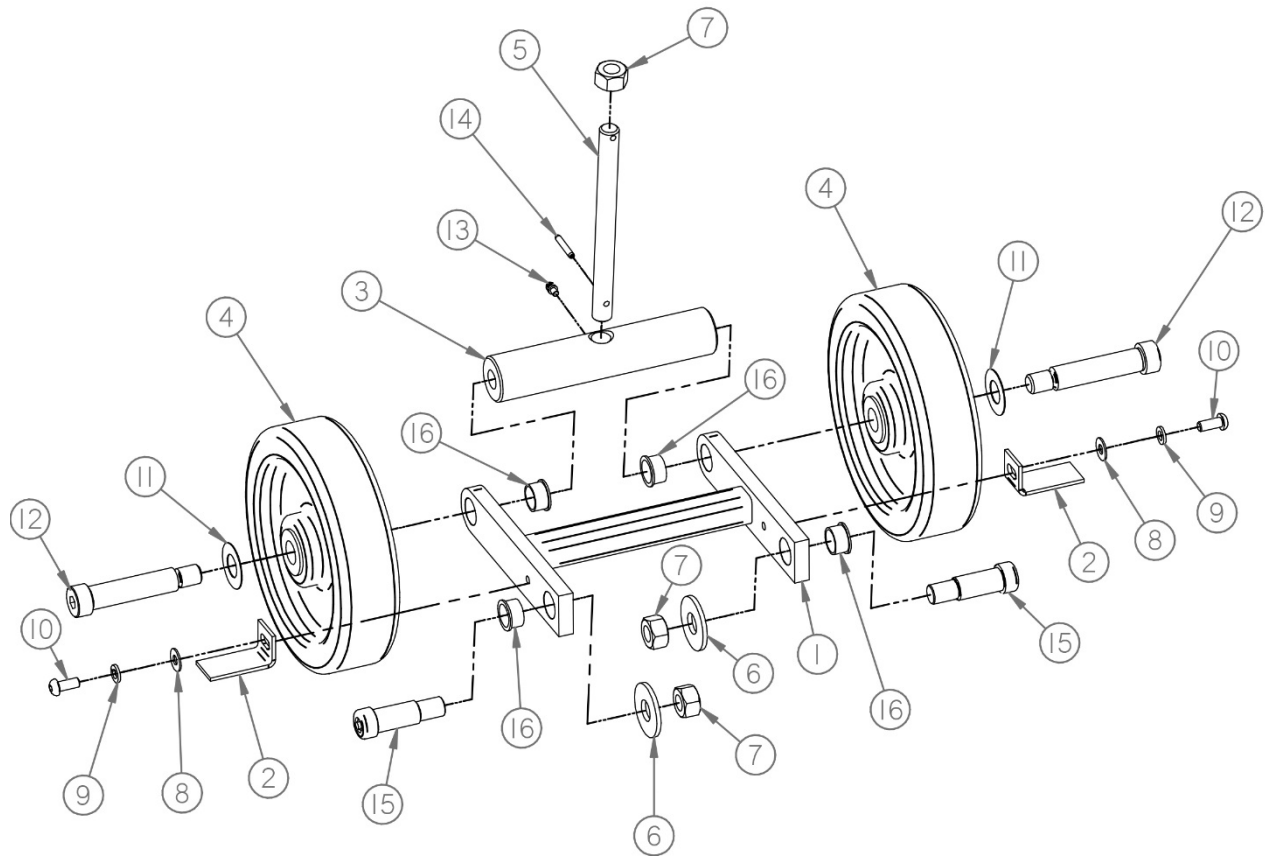

*Replacement Parts Diagram
 Adjustable Axle Assembly
 BRPFS108E Pro Floor Stripper*

Reference Number	Part Number	Description	Quantity
1	FCS16-0130	Weldment, Arm, Axle, (Includes Ref. 16)	1
2	FCS16-0090	Scraper, Wheel	2
3	FCS16-0060	Axle	1
4	FCS16-0240	Wheel	2
5	FCS16-0051	Screw, Jack	1
6	17100000	Washer, Flat, 5/8, ZY	2
7	18100000	Nut, Hex, 5/8-11, ZY	3
8	17040000	Washer, Flat, 1/4, ZY	2
9	16050000	Washer, Lock, 5/16, ZY	2
10	55050600	BHSCS, 5/16-18 X 3/4, ZY	2
11	200682	Washer, Plastic	2
12	62122400	Bolt, Shoulder, 3/4 X 3	2
13	550-0590	Fitting, Grease	1
14	20030900	Pin, Roll, 3/16 X 1-1/8	1
15	62121200	Bolt, Shoulder, 3/4 X 1-1/2	2
16	660-0410	Bearing, Oilite	4

Replacement Parts Diagram Orbital Plate Assembly BRPFS108E Pro Floor Stripper

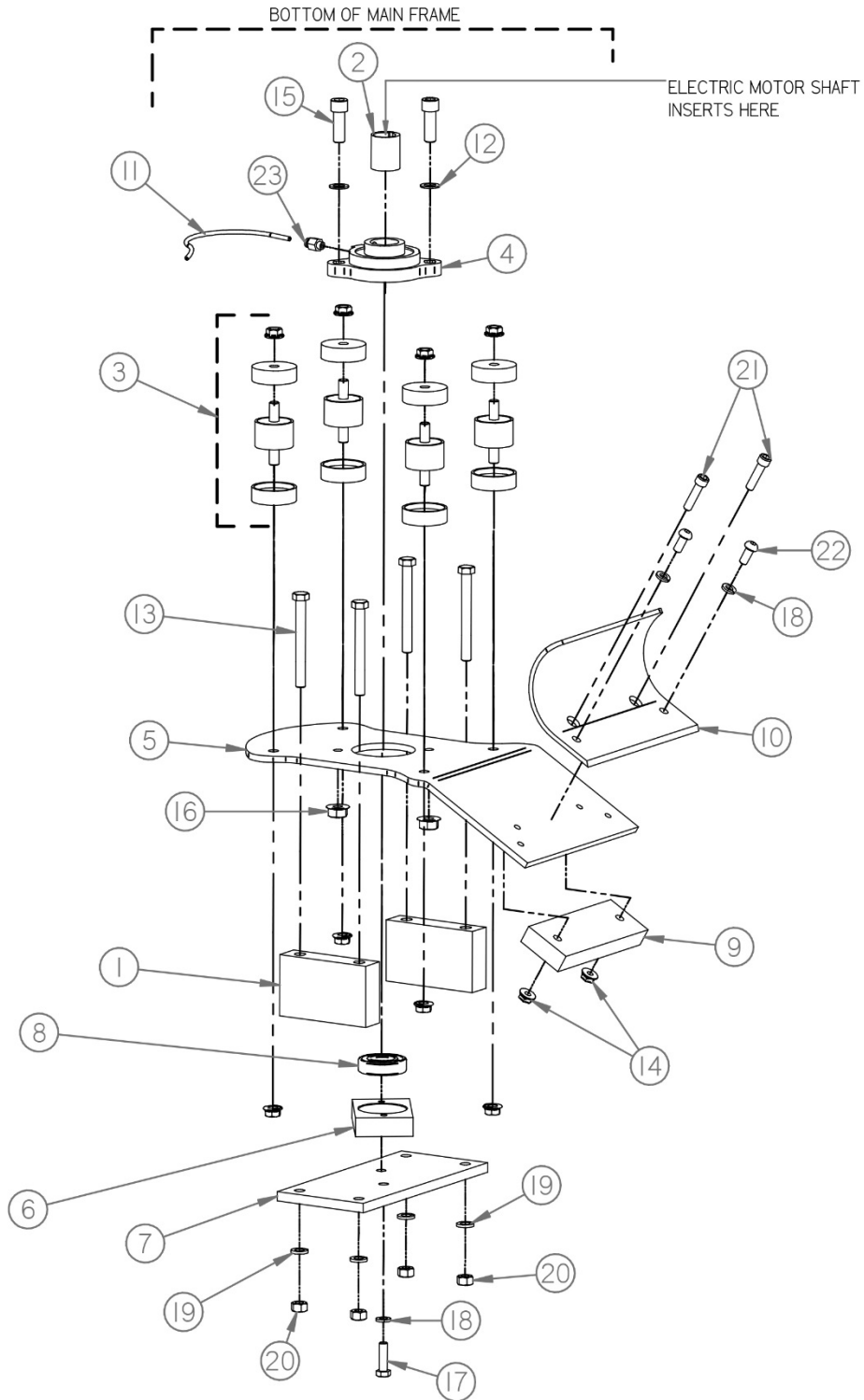

*Replacement Parts Assembly
Orbital Plate Assembly
BRPFS108E Pro Floor Stripper*

Reference Number	Part Number	Description	Quantity
1	FCS16-0371	Bar, Standoff	2
2	FCS16-0071	Hub, Offset	1
3	FCS16-0312	Assembly, Mount, Rubber	4
4	FCS16-0321	Bearing, Flange	1
5	FCS16-0023	Plate, Orbital	1
6	FCS16-0102	Block, Bearing	1
7	FCS16-0112	Plate, Bottom	1
8	FCS16-0331	Bearing, Support	1
9	FCS16-0390	Weight, Balance	1
10	FCS16-0191	Plate, Clamp	1
11	FCS16-0380	Hose, Grease	1
12	AN-960-716	Washer, Flat, 7/16, ZY	2
13	15062800	HHCS, 3/8-16 X 3-1/2, ZY	4
14	39050000	Nut, Whizlock, 5/16-18, ZY	2
15	60071000	SHCS, 7/16-14 X 1-1/4, ZY	2
16	86070000	Nut, Hex, Flange, 7/16-14, ZY	2
17	15050900	HHCS, 5/16-18 X 1-1/8, ZY	2
18	16050000	Washer, Lock, 5/16, ZY	4
19	16060000	Washer, Lock, 3/8, ZY	4
20	18060000	Nut, Hex, 3/8-16, ZY	4
21	60051000	SHCS, 5/16-18 X 1-1/4, ZY	2
22	55050600	BHSCS, 5/16-18 X 3/4, ZY	2
23	SG12-0130	Connector, Hose	1

Replacement Cutting Blades BRPFS105E Pro Floor Stripper

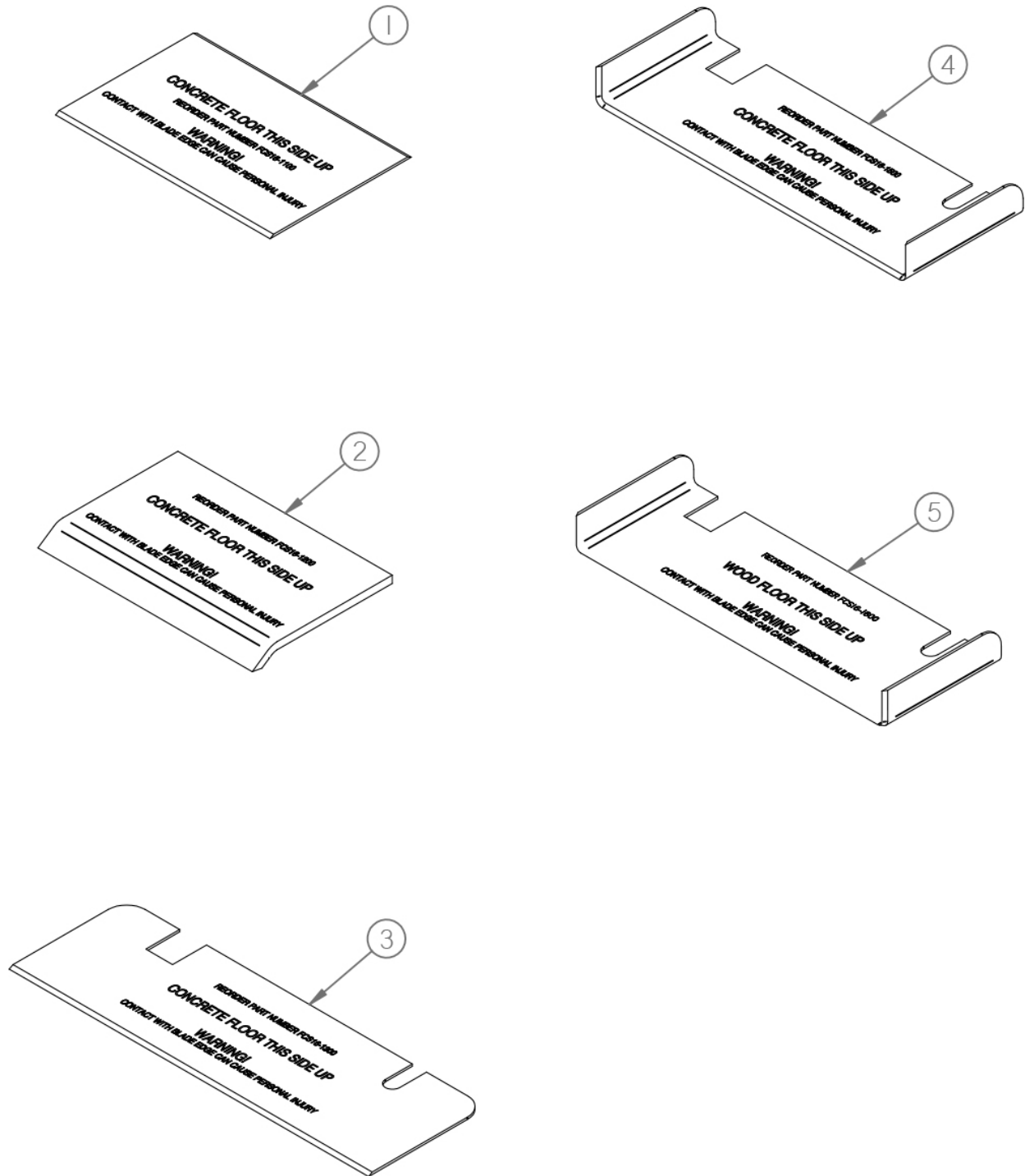

Replacement Cutting Blades BRPFS105E Pro Floor Stripper

Reference Number	Part Number	Description	Quantity
1	BR16-1100	Blade, Straight, 6L General Purpose Removal Projects On Both CONCRETE And WOOD Surfaces	1
2	BR16-1200	Blade, Removal, Mastic, 6L Mastic And Thin Film Coverings Removal On CONCRETE Surfaces ONLY	1
3	BR16-1300	Blade, Straight, 10L General Purpose Removal Projects On Both CONCRETE And WOOD Surfaces	1
4	BR16-1500	Blade, Scoring, 8L Glued Carpets And Sheet Type Linoleum, Rubber, PVC, Etc. Products On CONCRETE Surfaces ONLY	1
5	BR16-1600	Blade, Scoring, 8L Glued Carpets And Sheet Type Linoleum, Rubber, PVC, Etc. Products On WOOD Surfaces ONLY	1