

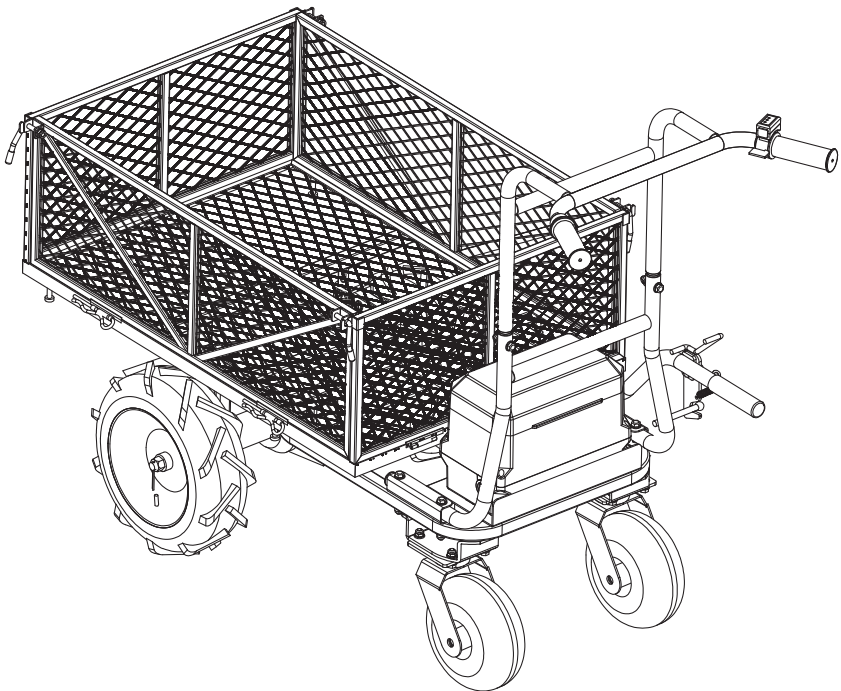

Electric Power Cart Operator's Manual



WARNING:

Read carefully and understand all **INSTRUCTIONS** before operating. Failure to follow the safety rules and other basic safety precautions may result in serious personal injury. Save these instructions in a safe place and on hand so that they can be read when required. Keep these instructions to assist in future servicing.

SPECIFICATIONS

Item No.	BW401.01
Rating	48 Volt DC/500W
Loading Capacity	300kgs/660lbs
Battery Pack	48V,2Ah,96Wh Lithium Battery
Speed	Forward:0-7km/h Variable, Reverse: 0-3.5km/h Variable

POWER CART SAFETY USE WARNINGS

1. Keep work area clean and well lit. Cluttered or dark areas invite accidents.
2. Wear shoes with non-slip treads. If you have safety shoes, wear them. Do not use your power cart while barefoot or wearing open sandals.
3. Do not operate power tools in explosive atmospheres, such as in the presence of flammable liquids, gases or dust. Power- tools create sparks which may ignite the dust or fumes.
4. Never operate your power cart in the rain or in tall wet grass. Remember, this is an electric garden cart.
5. Keep children and bystanders away while operating a power tool. Distractions can cause you to lose control.
6. When operating the machine, stand behind the machine and hold the handles firmly.
7. Do not operate the machine while riding on the machine.
8. Do not allow others to ride on the machine.
9. When operating the machine in reverse and walking backward, watch behind you and be careful not to slip or trip.
10. Do not use the machine when visibility is poor, because there is a risk of striking obstacles.
11. When operating the machine on rough ground, decrease speed and exercise caution.
12. When using the machine, avoid soft ground to prevent overturn due to the shoulder of the road collapsing.
13. Do not operate the machine on upward slopes greater than 15°.
14. If you find an abnormality, stop the machine on flat ground. Before inspecting the machine, step the brake lever and lock the brake, and then turn the power off.
15. Before operating the machine, make sure that the lock lever is fully pulled down and completely locked. If the lock is incomplete, there is a risk of accident or injury as the carrier or bucket may be tilted and the objects fall when going downhill.
16. Be careful not to entangle the cords with the load or obstacles.
17. Use only manufacturer-recommended replacement parts and accessories.

PERSONAL SAFETY WARNINGS

1. This is not a toy. Children under 14 years of age are not allowed to operate it.
2. Stay alert, watch what you are doing and use common sense when operating a power tool. Do not use a power tool while you are tired or under the influence of drugs, alcohol or medication.
3. Use personal protective equipment. Always wear eye protection. Protective equipment such as dust mask, non-skid safety shoes, hard hat, or hearing protection used for appropriate conditions will reduce personal injuries.
4. Prevent unintentional starting. Ensure the switch is in the off-position before connecting to power source and/or BATTERY pack, picking up or carrying the tool.
5. Remove any adjusting key or wrench before turning the power tool on. A wrench or a key left attached to a rotating part of the power tool may result in personal injury.
6. Do not overreach. Keep proper footing and balance at all times. This enables better control of the power tool in unexpected situations.
7. Dress properly. Do not wear loose clothing or jewelry. Keep your hair, clothing and gloves away from moving parts.
8. If devices are provided for the connection of dust extraction and collection facilities, ensure

- these are connected and properly used. Use of dust collection can reduce dust-related hazards.
9. Does not let familiarity gained from frequent use of tools allow you to become complacent and ignore tool safety principles. A careless action can cause severe injury within a fraction of a second.
 10. Always wear protective goggles to protect your eyes from injury when using power tools.
 11. It is an employer's responsibility to enforce the use of appropriate safety protective equipment's by the tool operators and by other persons in the immediate working area.

OPERATION ON SLOPS WARNINGS

1. Do not cross on slopes. Be sure to decrease speed and exercise caution.
2. Exercise caution when starting or stopping the machine on slopes.
3. As the loads become less stable on slopes, firmly secure the loads with ropes
4. As the machine becomes unstable depending on the condition of the road, keep the load to a minimum.
5. As the view is obscured on slopes, keep the height of the load to a minimum
6. Never park the machine on steep slopes. Park the machine on flat ground, pull the brake lever and lock the brake, and then turn the power off.
7. Do not change the direction or speed mode on steep slopes.
8. Do not release the switch trigger on upward slopes. The machine may go in reverse and cause an accident.
9. Make sure that the remaining battery capacity is enough before operating on slopes. If the remaining battery capacity is not enough, charge the battery or replace it with a charged one.

LOADING OBJECTIVE WARNINGS

1. Do not overload objects. When loading objects, be sure to follow the instructions and load limits in the manual.
2. Firmly secure the objects with ropes.
3. Load the objects within the carrier or bucket. If the objects protrude from the carrier or bucket, there is a risk of accidents due to the objects falling or contact obstacles such as walls.
4. Be sure that loaded objects are below eye level. If the load is too high, it is dangerous because the view is obscured. Also, there is a risk of overturning and injury because the load is likely to be unbalanced.
5. Load the objects on the carrier or bucket evenly. If the objects are loaded unevenly, there is a risk of overturning and injury because the load is likely to be unbalanced.
6. Before loading the objects or operating the machine, make sure that the lock lever is fully pulled down and completely locked.
7. Load and unload objects on flat ground.
8. When lifting and tilting the carrier or bucket, hold the handles and frame firmly, and work in a stable posture.

BATTERY POWER TOOL USE AND CARE WARNINGS







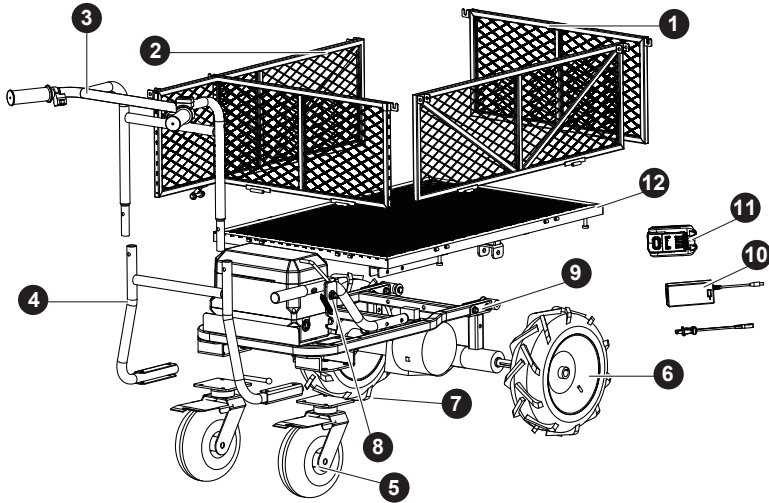





1. Ensure the switch is in the off position before inserting battery pack. Inserting the battery pack into power tools that have the switch on invites accidents.
2. Recharge only with the charger specified by the manufacturer. A charger that is suitable for one type of battery pack may create a risk of fire when used with another battery pack.
3. Use power tools only with specifically designated battery packs. Use of any other battery packs may create a risk of injury and fire.
4. When battery pack is not in use, keep it away from other metal objects like paper clips, coins, keys, nails, screws, or other small metal objects that can make a connection from one terminal to another. Shorting the battery terminals together may cause burns or fire.
5. Under abusive conditions, liquid may be ejected from the battery; avoid contact. If contact accidentally occurs, flush with plenty of soap and water. If liquid contacts eyes, immediately seek medical help. Liquid ejected from the battery may cause irritation or burns.

6. Avoid body contact with earthed or grounded surfaces, such as pipes, radiators, ranges and refrigerators. There is an increased risk of electric shock if your body is earthed or grounded.
7. Do not expose power tools to rain or wet conditions. Water entering a power tool will increase the risk of electric shock.
8. Do not abuse the cord. Never use the cord for carrying, pulling or unplugging the power tool. Keep cord away from heat, oil, sharp edges or moving parts. Damaged or entangled cords increase the risk of electric shock.
9. When operating a power tool outdoors, use an extension cord suitable for outdoor use. Use of a cord suitable for outdoor use reduces the risk of electric shock.

PACKAGE CONTENTS



Part No.	Description	Q'ty	Part No.	Description	Q'ty
1	Front & Back frame	2	7	Front wheel (Left)	1
2	Left & Right frame	2	8	Handle	1
3	Handle (Up)	1	9	Chassis Frame	1
4	Handle (Down)	1	10	Charger	1
5	Caster	2	11	Battery	2
6	Front wheel (Right)	1	12	Chassis Frame	1

 $\varnothing 5 \times 110$ X8	 3.2*36 X2	 2.5*45 X2
 Right Handle X2	 M8*40 X2	 $\varnothing 10$ X4
 Left handle X2	 M8*25 X8	 Plug X2
 5*5*25A X2	 M8*70 X4	 M8*45 X6
	 M14 X2	

ASSEMBLE WHEEL

1. Unpack the carton and take everything out. Move the cart base and wheels aside for assembly first.
2. Align the wheel (1) groove with the motor drive axle (2) groove, assemble the wheel on and put the flat key(3) entirely into the key groove. Tighten the wheel by nut(4) and lock by Cotter Pin(5).
3. Assemble another wheel (6) in the same way.

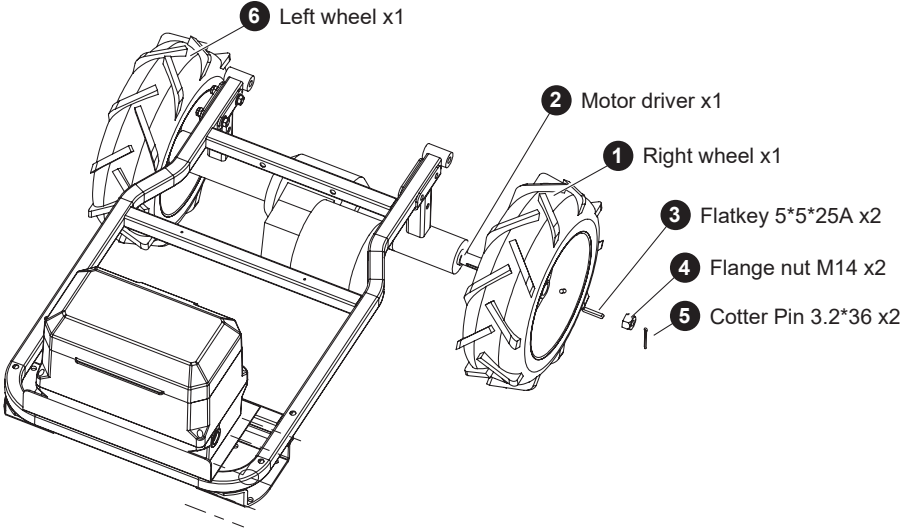

ASSEMBLE CASTER WHEEL

1. Use 4pcs part#1 and 4pcs part#3 to fix part#2 on part#4
2. Assemble another wheel in the same way.

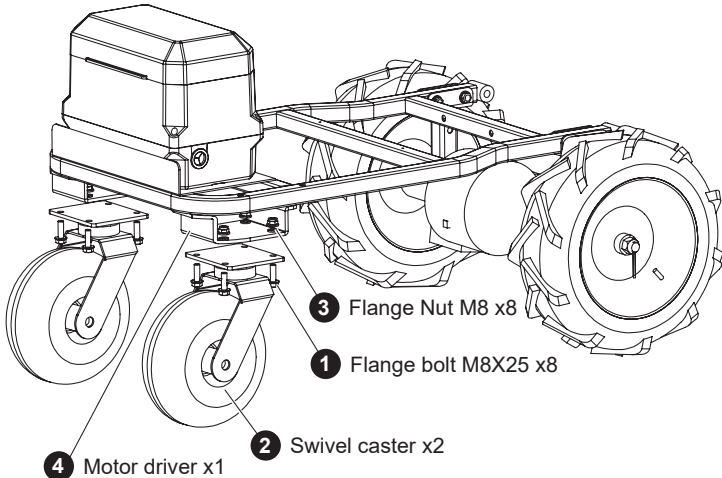

ASSEMBLE HANDLE

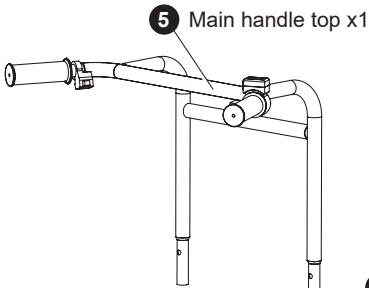

1. Place the main handle of bottom part (1) into the base frame (2), fixed by Flange bolt (3) & Flange Nut(4).
2. Insert the main handle of top part (5) into bottom part (1) tube, fixed by Flange bolt (6) and nut (4).

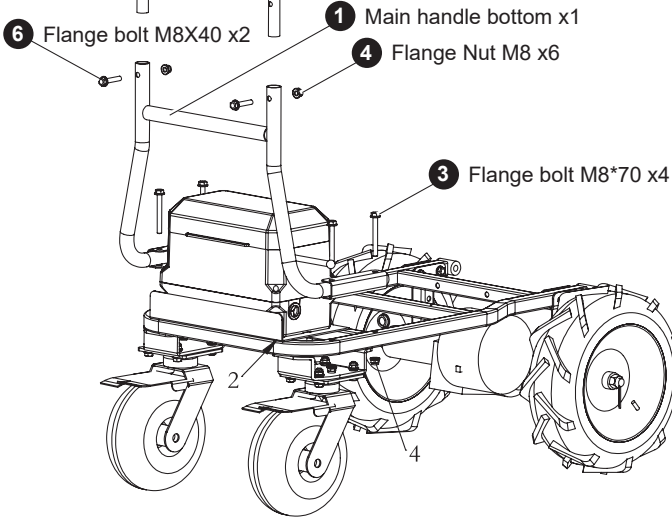

ASSEMBLE MAIN FRAME

1. Take the bottom wire deck(2), face the flat wire upside and position the dumping handle groove side to main handle. Put the bottom wire deck(2) on to the base frame (1) , fasten by bolt (3) and washer (4), locked by the pin (5).

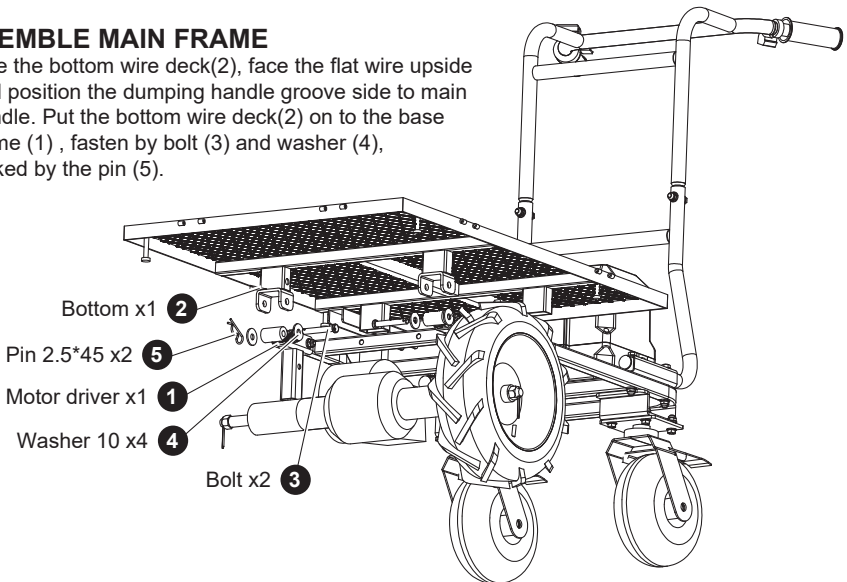

ASSEMBLE MAIN HANDLE

1. Attach the dumping handle(3) to the bottom wire deck(2), screwed by Flange bolt (1) and nut(4).

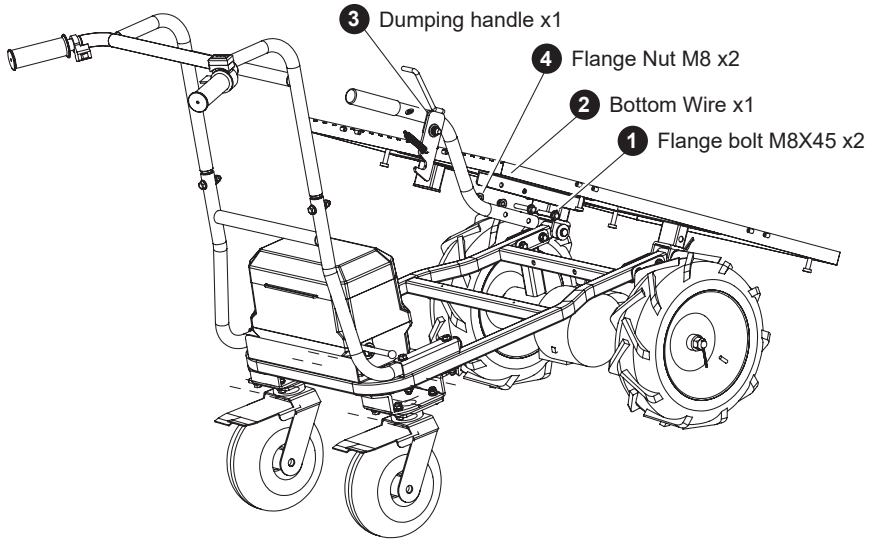

ASSEMBLE GUARD BAR

1. Assemble the left & right frame (3), and the front & back frame (1), locked by Pin (5).
2. Locking the entire frame by handle bar (4), the electric cart assembly finished.

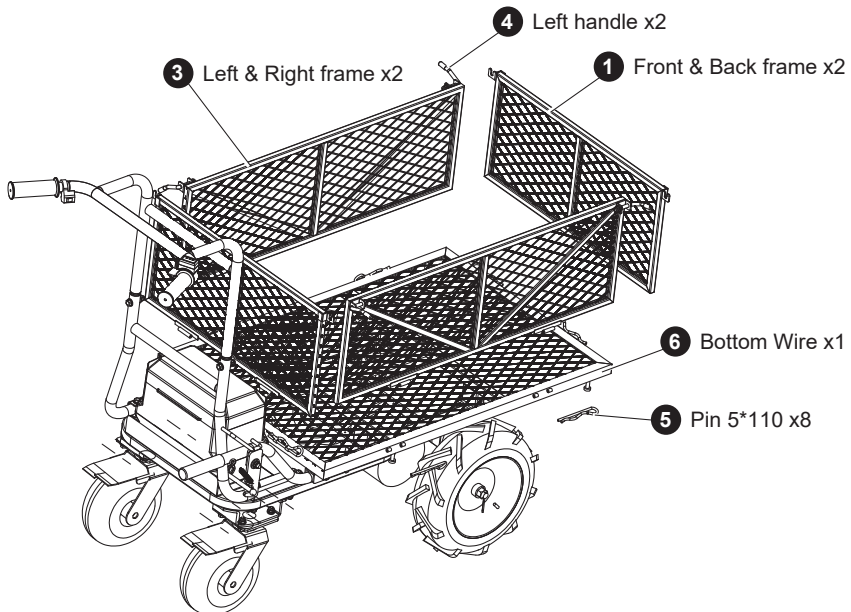

The finished power cart can be two types, with the side frames or without side frames. Power cart without side frames is for abnormal sizes items, which need to be loaded within the loading capacity and in reasonable size to keep the cart be balance.

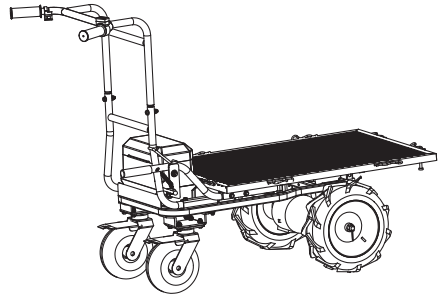
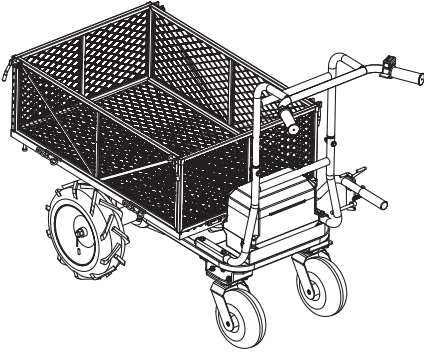

OPERATION

1. Open the battery box, turn on the power switch (1), there are 2 battery compartments, make sure the battery switch button on the right position (2).

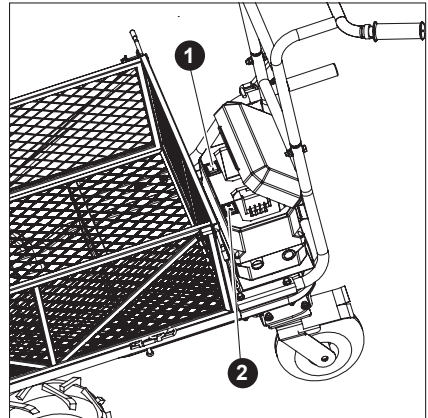

2. Press the start switch (1) on the right handle, then the battery indicator (2) will light up with all 3 LED lights and machine is ready for working. Press and hold the Switch trigger (3) to start working. By pressing less or more to control the moving speed.

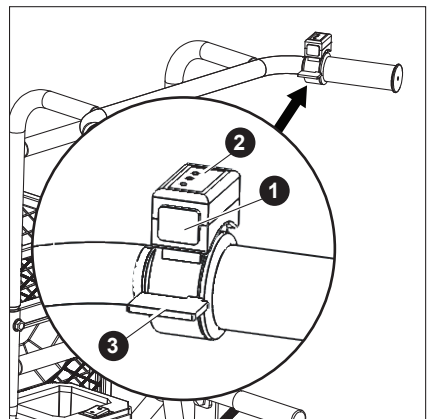

3. Use the direction button (1) on the left handle for forward and reverse.

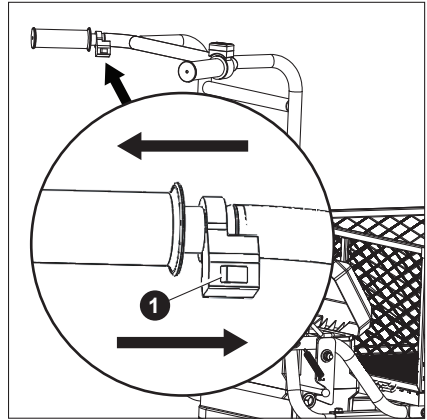

4. Release the lock lever (1) out from the dumping handle holder, push the dumping handle to lift the cart for dumping.

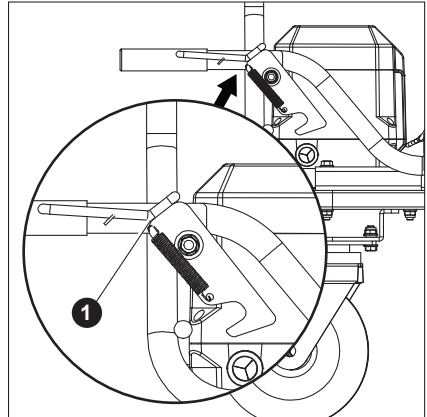

OPERATION ON SLOPS WARNINGS

1. Do not cross on slopes. Be sure to decrease speed and exercise caution.
2. Exercise caution when starting or stopping the machine on slopes.
3. As the loads become less stable on slopes, firmly secure the loads with ropes.
4. As the machine becomes unstable depending on the condition of the road, keep the load to a minimum
5. As the view is obscured on slopes, keep the height of the load to a minimum
6. Never park the machine on steep slopes. Park the machine on flat ground, pull the brake lever and lock the brake, and then turn the power off.
7. Do not change the direction or speed mode on steep slopes
8. Do not release the switch trigger on upward slopes. The machine may go in reverse and cause an accident.
9. Make sure that the remaining battery capacity is enough before operating on slopes. If the remaining battery capacity is not enough, charge the battery or replace it with a charged one.

REMAINING BATTERY CAPACITY CHECKING

During the normal working, the 3 LED lights of battery indicator are all on which means the battery is in full power. When the orange light in the middle starts to flash, it warns the power shortage and battery need to be charged or changed to a new one. If the lights turn to red, the machine stops automatically.

BATTERY CHARGE

1. Battery charge: When the battery is low capacity, please do recharge. Open the battery box, unplug the lithium battery, and connected with the charge (1) side., and connect the charge plug (3) with electric power to start charging. Once the adaptor light (2) turns green, the battery is fully charged.It usually takes about 1-2 hours. For a long service life of the battery, please recharge only with charger specified by the manufacture.

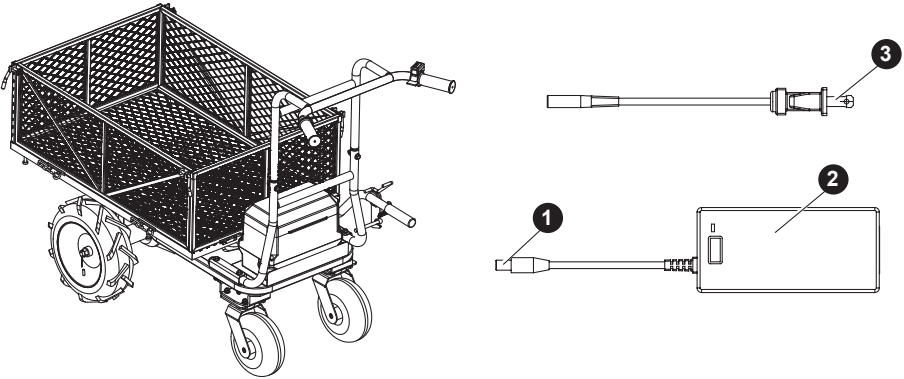

TROUBLE SHOOTING

Problem(s)	Possible Cause	Corrective Action
The power cart does not run.	Battery is not charged.	Charge the battery pack according to the instructions included with you model.
	The wire is loose.	Check all the connectors and to see if any partis loose or not.
	The controller is damaged.	Replace the damaged one with specific controller.
The power cart runs sluggishly.	Battery volume is low.	See the battery indicator to check the volume. Charge the battery pack according to the instructions included with you model.
	The battery is old and does not accept full charge.	Replace the battery with a new one.
	The conditions are too stressful for your power cart.	The cart is intended for residential use.If slopes are too steep or the terrain too bumpy,your cart might experience a noticeable decrease in performance.

WARRANTY

All new machinery is supplied with limited 12 months Warranty.

1. The manufacturer warrants this electric power cart against defects in material and craftsmanship, for a period of 12 months from date of original purchase;
2. Items considered as consumable parts are not normally covered by the warranty, including but not limited to: Batteries, Electric cables; Filters;
3. This warranty excludes parts that are worn or damaged due to normal wear, routine tune up or adjustment, abuse/misuse or neglect, overheating lack of maintenance, fittings/fasteners becoming loose/detached through lack of maintenance.
4. The warranty does not cover damage caused by accident, misuse or faulty installation, improper handling, routine maintenance items such as O-rings, seals, and lubricants, accessory parts.
5. The electric power cart must be installed and maintained in compliance with the instructions.

PARTS BREAKDOWN

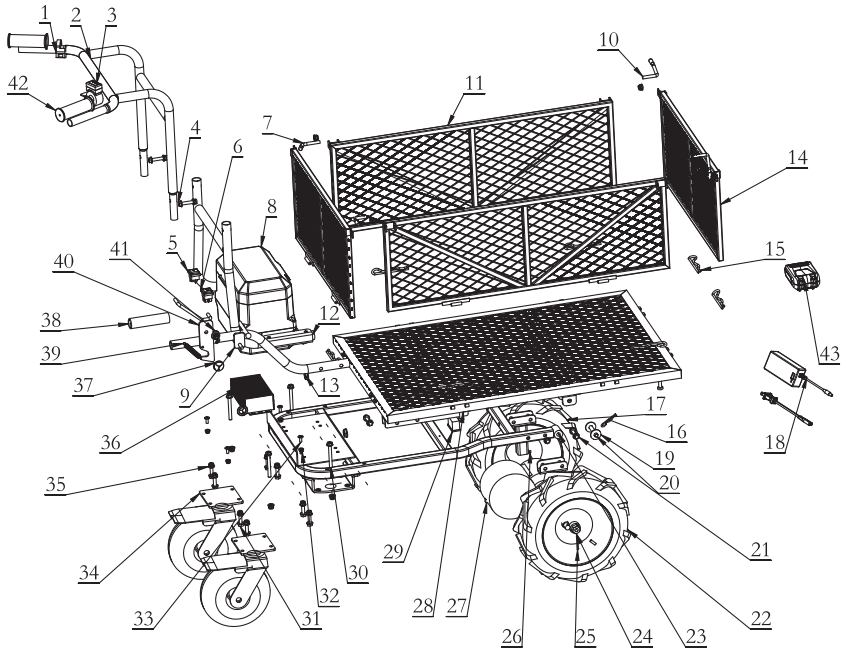

Part No.	Description	Q'ty	Part No.	Description	Q'ty
1	Left handle switch	1	23	Chassis Frame	1
2	Round tube handle (Up)	1	24	All Metal Hex Lock Nuts M14	2
3	Turn right handle	1	25	Cotter pin 3.2*36	2
4	Hexagon flange bolts M8x40	2	26	Flat key	2
5	Switch	1	27	Drive axle	1
6	Transfer switch	1	28	Main Frame	1
7	Left handle	2	29	Rubber Plug	2
8	Battery Box	1	30	Hexagon flange bolts M8*70	4
9	Handle	1	31	Hexagon flange bolts M8*25	8
10	Right handle	2	32	Hexagon flange bolts M6	4
11	Left & Right guard bar	2	33	Cross Recessed Flat Head Screws M6*15	4
12	Round tube handle (Down)	1	34	Caster	2
13	Round tube plug	3	35	Non-metallic insert lock nut M8	25
14	Front & Back guard bar	2	36	Controller	1
15	B type pin 5*110	8	37	Rubber Plug	2
16	Pin 2.5*45	2	38	Handle Sleeve	1
17	Left front wheel	1	39	Extension Spring	1
18	Charger	1	40	Hook	1
19	Large washer ϕ 10	4	41	Washer	2
20	Plug	2	42	Sleeve	2
21	Hexagon flange bolts M8*45	6	43	Li-Battery	2
22	Right front wheel	1			



Goodyear (and Winged Foot Design) and Blimp Design are trademarks of
The Goodyear Tire & Rubber Company used under license by
Intradin (Shanghai) Machinery Co.Ltd., China.
Copyright 2023 The Goodyear Tire & Rubber Company.