

www.swisherinc.com

OWNER'S MANUAL

STARTING SERIAL #:
L121-046001

MODEL NO.

**FC14560CPKA
FC14560CPKA-CA**



IMPORTANT

Read and follow all
Safety Precautions
and Instructions
before operating this
equipment.

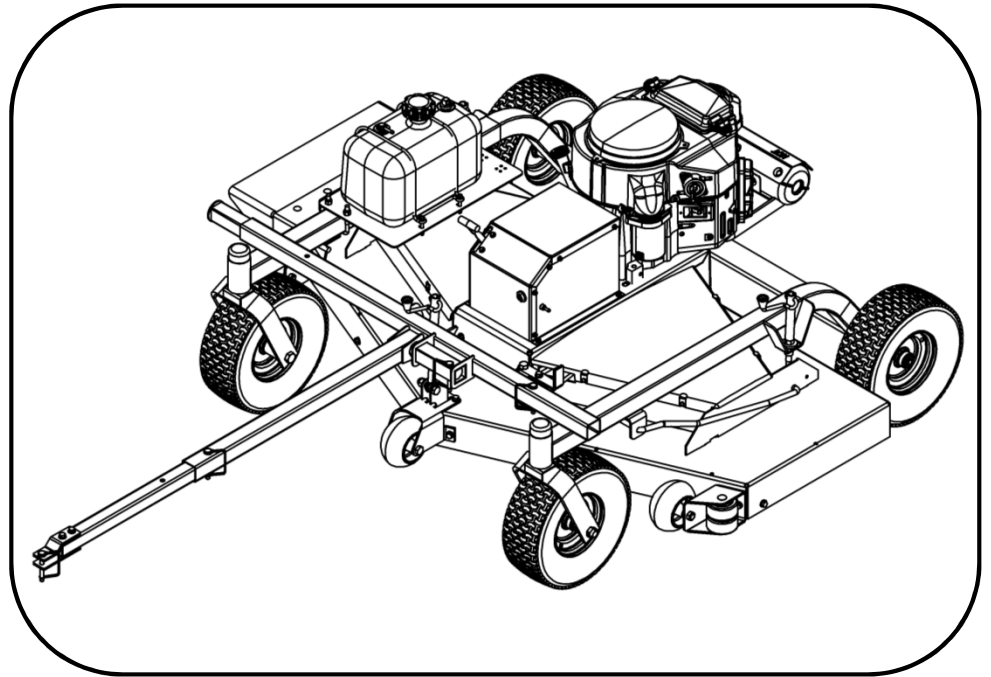

SWISHER[®]

COMMERCIAL PRO 60" FAST FINISH TRAIL MOWER

**Assembly
Operation
Service and Adjustment
Repair Parts**

SWISHER ACQUISITION INC.

1602 CORPORATE DRIVE., WARRENSBURG MO 64093

PHONE 800-222-8183 FAX 660-747-8650 EMAIL CustomerCare@SwisherInc.com

2/5/2021

Made In The

USA

of US and Global Parts

LIMITED WARRANTY

The manufacturer's warranty to the original consumer purchaser is: This product is free from defects in materials and workmanship for the period's shown below beginning from the date of purchase by the original consumer purchaser. We will repair or replace, at our discretion, parts found to be defective due to materials or workmanship. This warranty is subject to the following limitations and exclusions:

As required by CFR § 1060.120, the fuel system related components, which have been certified to this equipment by SAI are to be free of defects in material and workmanship for a period of two (2) years from the date of purchase by the original consumer purchaser.

- 1) Engine Warranty All engines utilized on our products have a separate warranty extended to them by the individual engine manufacturer. Any engine service warranty is the responsibility of the engine manufacturer and in no way is Swisher or its agents responsible for the engine warranty. The Kawasaki Engine Service Hotline is 1-877-364-6404 or email kawpower-website@kmc-usa.com

- 2) Commercial Use This product has a 1yr Limited Commercial - 2 Year Limited Consumer on All Non-Engine Parts from the date of purchase.

- 3) Limitations This warranty applies only to products, which have been properly assembled, adjusted, and operated in accordance with the instructions contained within this manual. This warranty does not apply to any product of Swisher that has been subject to alteration, misuse, abuse, improper assembly or installation, shipping damage, or to normal wear of the product.

- 4) Exclusions Excluded from this warranty are normal wear, normal adjustments, and normal maintenance.

In the event you have a claim under this warranty, you must return the product to an authorized service dealer. All transportation charges, damage, or loss incurred during transportation of parts submitted for replacement or repair under this warranty shall be borne by the purchaser. Should you have any questions concerning this warranty, please contact us toll-free at 1-800-222-8183. The model number, serial number, date of purchase, and the name of the authorized Swisher dealer from whom you purchased the mower will be needed before any warranty claim can be processed.

THIS WARRANTY DOES NOT APPLY TO ANY INCIDENTAL OR CONSEQUENTIAL DAMAGES AND ANY IMPLIED WARRANTIES ARE LIMITED TO THE SAME TIME PERIODS STATED HEREIN FOR ALL EXPRESSED WARRANTIES. Some states do not allow the limitation of consequential damages or limitations on how long an implied warranty may last, so the above limitations or exclusions may not apply to you. This warranty gives you specific legal rights and you may have other rights, which vary from state-to-state. This is a limited warranty as defined by the Magnuson-Moss Act of 1975.

SAFETY PRECAUTIONS



This Safety Alert Symbol indicates important messages in this manual. When you see this symbol, carefully read the message that follows and be alert to the possibility of personal injury.

Read this manual completely. This machine can amputate hands, feet, and throw objects. Failure to observe the following safety instructions could result in serious injury or death.

- Read the manual. Learn to operate this machine safely.
- Always disconnect the spark plug wire and place the wire where it cannot contact the spark plug, to prevent accidental starting the engine when setting up, transporting, adjusting or making repairs.
- Keep all shields and guards in place.
- Understand the speed, steering and stability of this machine. Know the positions and operations of all controls before you operate this machine. Check all of the controls in a safe area before starting to work with this machine.
- Allow only responsible adults who are familiar with these instructions to operate this machine. Never allow children to operate this machine.
- Clear the area of objects such as rocks, toys, wire, etc. that can be picked up and thrown by the blade.
- Be sure the area is clear of other people before mowing. Be aware of the mower discharge direction and do not point at anyone. Stop the machine if anyone enters the mowing area. Children are often attracted to the machine and the mowing activity. ***Never assume that children will remain where you last saw them.*** Keep children under the watchful care of another responsible adult.
- **No riders!**
- Do not put hands or feet near or under rotating parts. Keep clear of the discharge opening at all times.
- Do not mow in reverse. Always look down and behind before and while backing.
- Turn off the blades when not mowing. Before leaving the machine, turn off the blades and stop the engine.
- Watch for traffic when operating near or crossing roadways.
- Do not operate the mower if it has been dropped or damaged in any manner or if the mower vibrates excessively. Excessive vibration is an indication of damage. Repair mower as necessary.
- Dress properly. Do not operate the mower when barefoot or wearing open sandals. Wear only solid shoes with good traction when mowing.
- Do not operate the machine while under the influence of alcohol or drugs.
- Do not operate on slopes greater than 15 degrees.
- Never tamper with safety devices. Check their proper operation regularly.
- Stop and inspect the equipment if you strike an object. Repair, if necessary, before restarting.
- Never make adjustments or repairs with the engine running.



SAFETY DECALS

Replace decals immediately if damaged. Order by part number from Swisher.



OD45- Warning Decal



OD11- No step Decal



OD55- Triangle Danger Decal



OD43- Flying Debris Decal



OD33- Speed Decal



OD29- Danger Decal

REQUIRED ASSEMBLY

FRONT WHEEL CASTER ASSEMBLY

1. Remove single nut and washers from caster shaft.
2. Place one washer (NB195) on the shaft of the caster/wheel subassembly.
3. Slide same shaft through the bearing/frame with wheel towards the ground.
4. Place the other washer (NB195) on the shaft; it should be resting on the top bearing.
5. Add thin washer (17x195).
6. Thread nyloc jam nut onto shaft.
7. Tighten nut snugly, making sure shaft threads enter the nyloc of the nut. **Over-tightening of this nut will bind caster.**
8. Repeat process for other front side.
9. Push on plastic dust covers over nut and thin washer until it snaps into place.

REAR WHEEL ASSEMBLY

1. Remove cotter pin from axle and remove thin washer (NB149) from axle. Leave two NB178 washers on axle.
2. If necessary (to take up space) slide extra washer (NB178) over axle, then wheel (with valve stem out).
3. Slide on washer (NB149) and replace cotter pin in end of axle.
4. Bend cotter pin so it will not fall out.
5. Repeat process for other wheel.

OFFSET & CENTER TOW HITCH BAR ASSEMBLY

1. Lay out parts according to the diagram.
2. Insert part 661A into part 662 and pin with the hitch pin (H11).
3. Insert part 20954 into part 661A. Choose from the 3 holes to set the desired hitch length. Pin with a hitch pin (H11).
4. Part 662 slides into the front tube of the frame. Again, choose from the 3 holes to arrange desired offset. Pin with a hitch pin (H11).
5. Eliminate step 2 for hitching from the center bracket. Only one method can be used at a time.

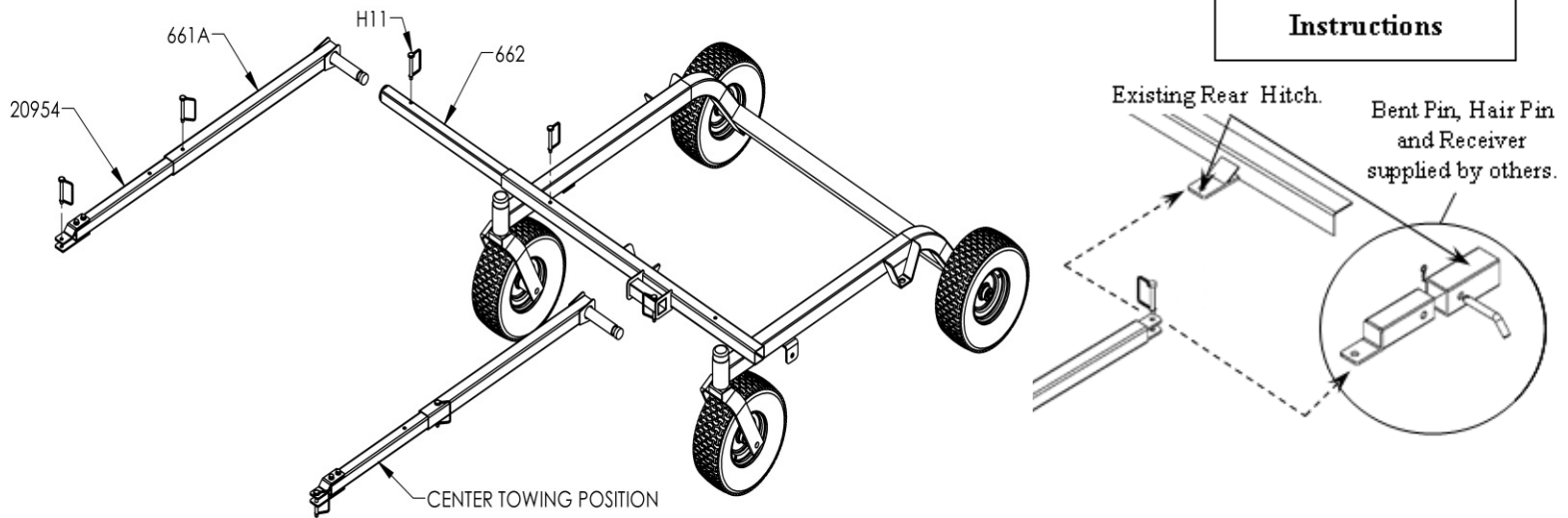

**ATV or Utility
Vehicle Attachment
Instructions**

A U1 battery is required (not included). Position battery hold down bracket as shown. Tighten nuts so battery will not shift position.

Battery Mounting Detail

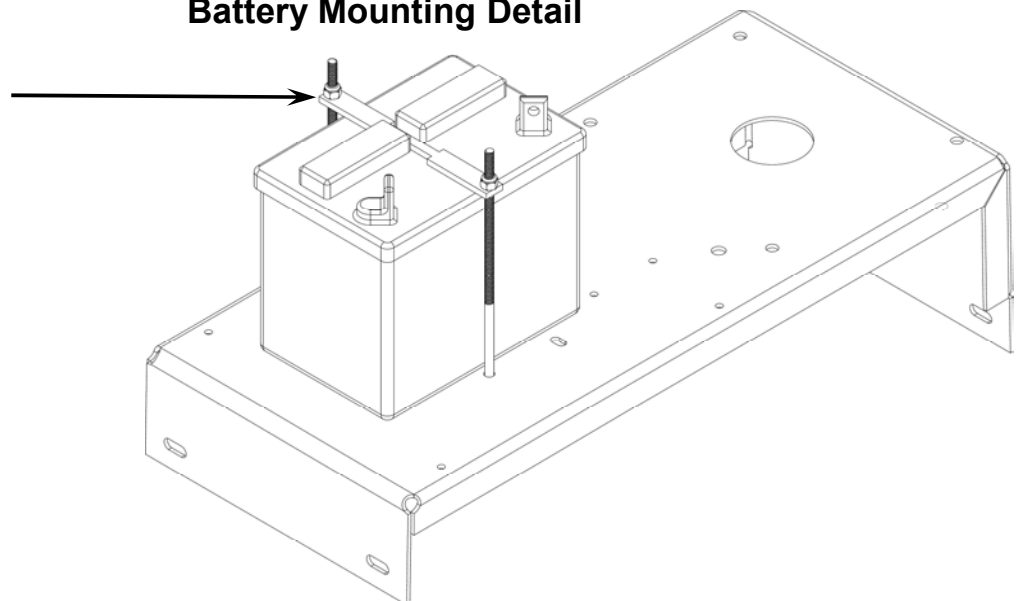

* Battery cover not shown

OPERATING YOUR TRAIL MOWER



The operation of any mower can produce foreign objects to be thrown into the eyes, resulting in severe eye damage. Always wear certified safety glasses or wide-vision safety goggles over spectacles before starting any cutting machine and while operating such a machine.



The operation of any cutter produces sound waves that are damaging to the human ear. Ear protection is recommended.



CAUTION!

Tragic accidents can occur if the operator is not alert to the presence of children. Children are often attracted to the machine and the mowing activity. *Never assume that children will remain where you last saw them.*

INTENDED USE

This Trail Mower is designed to produce a quality finish cut on lawns, golf courses, etc. It is **not** designed to clear brush or cut saplings. Your Trail Mower should be towed behind an ATV, a golf cart, lawn tractor, or similar approved vehicle. It is not meant for speeds exceeding 5 mph.

ATTACHING TRAIL MOWER TO TOW VEHICLE

- Place mower behind vehicle and back vehicle up to desired attaching position.
- When offsetting Trail Mower do so to side opposite the discharge of the tow vehicle.
- Attach tow hitch (661) to the swivel hitch with hitch pin (H11). Make certain hitch pin goes completely through each piece and is clipped to prevent accidental separation.
- Attach red safety tether (6736) to both the towing vehicle and to the Trail Mower toggle switch (685SP), located on the left battery side cover (17614). Its purpose is to manually stop mower engine or to stop mower engine in case the two machines become separated. (See Motor Base Detail page 14).
- **It is extremely important the safety tether is secured properly to both the toggle switch and the towing vehicle.**

STARTING THE ENGINE

See engine manufacturer's instructions for the type and amount of oil and fuel used. Trail Mowers with electric start engines will need a battery (sold separately). Swisher recommends using a standard "U 1 R" lawn & garden battery.

IMPORTANT: This engine is not equipped with a spark arrester muffler. It is a violation of California Public Resource Code Section 4442 to use or operate the engine on any forest-covered, brush-covered, or grass-covered land. Other states or federal areas may have similar laws.

- Engine must be level to accurately check and fill oil. Do not overfill.
- Make sure the tow vehicle parking brake is set, mower is level, and blades are disengaged.
- Check spark plug wire, oil, and fuel.
- Check all electrical connections (See Schematics).
- Make sure toggle switch is turned “ON” and the red tether is properly attached.
- Set engine idle to “CHOKE” position.
- With feet clear of mower deck, turn key switch to the “START” position and release when engine begins to run.
- Set engine idle at desired RPM.

BREAKING IN YOUR MOWER

- Set vehicle parking brake or chock wheels to prevent accidental rolling.
- Start engine properly.
- Slowly, engage blade control.
- In a safe environment, i.e. no children, allow blades to rotate and engine to idle for 5 minutes. This breaks in the belts and the engine.
- Stop mower properly.



CAUTION!

SHUT OFF MOWER ENGINE AND REMOVE SPARK PLUG WIRE FROM SPARK PLUG BEFORE MAKING ANY ADJUSTMENTS TO THE MOWER.

MOWER HEIGHT ADJUSTMENT

- Adjust while mower is **not** running.
- The cutting range is approximately 1” to 5.5”. The height should be measured from the ground to the blade tip without the engine running.
- Rotate height adjust crank handles (H7N) in a clockwise direction to lift the mower deck. A counter-clockwise direction is used to lower the mower deck.
- Make sure the height adjustment is the same at side crank handles. For best results, see “SUGGESTED PRACTICE” section. Graduated scales are for reference only, not the actual cutter height.
- Place crank handle in a retracted position to maintain height adjustment.

STARTING TO MOW

- Adjust the cutting height.
- Double check vehicle to mower attachment.
- Start mower engine properly.
- Slowly, activate the blade engage lever (21929) by rotating it forward and left until the lever locks into place.
- Carefully mount tow vehicle and start mowing slowly.

STOPPING THE MOWING SESSION

- Pull safety tether to shut toggle switch “OFF”. If the engine fails to stop or if the safety tether has become inoperable, then use Alternative Stopping Method.

ALTERNATIVE STOPPING METHOD

- Bring vehicle to complete stop, shut off engine, and set parking brake.
- Disengage blade engage lever (21929).
- Manually shut toggle and key switches to their “OFF” positions.
- Always remember to remove keys to avoid irresponsible usage.

TRANSPORTING MOWER

- Stop mower properly.
- Place mower deck in its highest position.
- If transporting without the use of a tow vehicle, then remove spark plug wire and place where it cannot contact the spark plug.

SUGGESTED MOWING PRACTICES

- Operate mower engine at full throttle to assure the best cutting performance and maximum material discharge.
- Allow wet grass to dry. Clumps of wet grass will collect under the mowing deck.
- Mowing should be started with tow vehicle in low gear and increased only as safe mowing conditions permit. This speed should not exceed 5 mph.
- The average lawn should be cut to approximately 2.5” during the cool season and to over 3” during the hot months.
- For a healthier lawn and better aesthetics, your lawn should be mowed often and after moderate growth.
- When cutting high or dense grass areas go slowly. Some areas may need to be mowed twice. The second cut should be at 90 degrees to the first, if possible.
- **Mowing thick or high grass.** Raise rear height crank handles to .5”-.75” above the other two handles.
- **Creating a manicured lawn.** Lower rear height crank handle to .25”-.5” below front of deck. This allows grass blades to be cut twice. It also continually cuts clippings to produce a mulching effect.

GENERAL TROUBLE SHOOTING

- The mower is not cutting level.
 - Level deck, making sure the side crank-handles are equal.
 - Check air pressure of all tires; make sure they are equal, and to manufactures specifications.
 - Examine blades for damage, while mower engine is not running.
- The engine will not start.
 - Disengage blades, turn toggle switch to “ON” position, check battery and all other electrical connections, and inspect spark plug and wire.
 - Check for fuel in the engine.
- Engine runs poorly.
 - See engine manual.
 - Check throttle adjuster.
 - Replace fuel, clean fuel filter and fuel line.



IF PROBLEMS PERSIST HAVE A QUALIFIED MECHANIC SERVICE THE MOWER. NEVER ATTEMPT TO MAKE AN ADJUSTMENT THAT YOU ARE NOT SURE IS CORRECT. DOING SO CAN CAUSE OTHER PROBLEMS.

MOWER MAINTENANCE

GENERAL RECOMMENDATIONS

The warranty on this Trail Mower does not cover items that have been subjected to operator abuse or negligence. To receive full value from the warranty, operator must maintain unit as instructed in this manual.

Some adjustments will need to be made periodically to maintain your unit properly.

All adjustments in this manual should be checked at least once each season.

Periodically inspect and clean excessive debris inside the battery cover (17340) and belt covers (18391). Disconnect spark plug wire before cleaning.

BEFORE EACH USE

- Check engine oil level on a level surface. Check twice to insure an accurate reading.
- Check condition of air filter; clean and replace as necessary.
- Check blade operation; keep blades in good condition.
- Check for loose fasteners and tighten them as needed.

AFTER EACH USE

- Keep blades sharp.
- Remove fresh grass clippings with garden hose.
- Grass clippings hardened to the underside should be scraped out with a putty knife.
- Keep fluids at proper levels.
- Cover unit to prevent rain or other debris buildup. Definitely cover the engine.

BEFORE AND/OR AFTER EACH SEASON

- Replace the spark plug.
- Clean or replace the air filter.
- A new spark plug and clean air filter assure proper air-fuel mixture and help your engine run better and last longer.
- Check blades and belts for wear. Replace as necessary.

STORAGE RECOMMENDATIONS

⚠ CAUTION! Do not store engine indoors or other poorly ventilated area. Keep engine away from gas appliances where fumes could contact open flame, pilot lights, or sparks.

⚠ If engine is to be stored for 30 or more days, prepare unit as follows:

- Drain fuel outside into an approved container.
- Start engine properly and run until unit is out of fuel.
- Let engine cool.
- Remove remaining gasoline from carburetor and fuel tank to prevent gum deposits from forming within the engine. Gum deposits can cause malfunction in the engine.
- Store mower with blades disengaged to prevent belts from being permanently stretched.

BLADE CARE AND SERVICE

For best results cutter blades must be kept sharp. The blades can be sharpened with a few strokes of a file or grinding wheel. Do not attempt to sharpen blades while they are on the mower. ***Disconnect spark plug wire before servicing unit.***

Important: Replace blades that have been damaged or deeply nicked.

Important: Check blade and spindle hardware on a regular basis to make sure nuts are tight.



Only a qualified mechanic should be used for any adjustments, disassembly or other kind of repairs.

FRAME ASSEMBLY

ITEM #	QTY.	PART NO.	DESCRIPTION	ITEM #	QTY.	PART NO.	DESCRIPTION
1	1	662*	Weldment - Tongue Offset Extension	10	3	10579	Bushing -Stepped Height Adjust
2	1	661A*	Weldment - Solid Stock Hitch	11	6	NB126	Pin - 1/8" X 1" Cotter
3	4	H11	Pin - Safety Hitch	12	4	T2PB	Bushing - Plastic
4	2	NB622	Bolt - Serr Flange, 5/16-18X2 1/4	13	3	10038	Bolt - Eye
5	1	21152*	Plate - Clevis, Top	14	1	3665	Bar - Left Sway
6	1	20953*	Tube - Tow Hitch	15	1	17600*	Weldment - T60 Frame
7	1	21153*	Plate - Clevis, Bottom	16	4	NB178	Washer - 5/8 ID X 1 OD 10 GA
8	2	NB170	Nut - Serr Flange 5/16-18	17	2	F4157WK	Wheel/Tire
9	1	3664	Bar - Right Sway	18	2	NB149	Washer - 5/8 ID X 1 OD 14 GA

ITEMS 4-8 ARE PART OF ASSEMBLY 20954

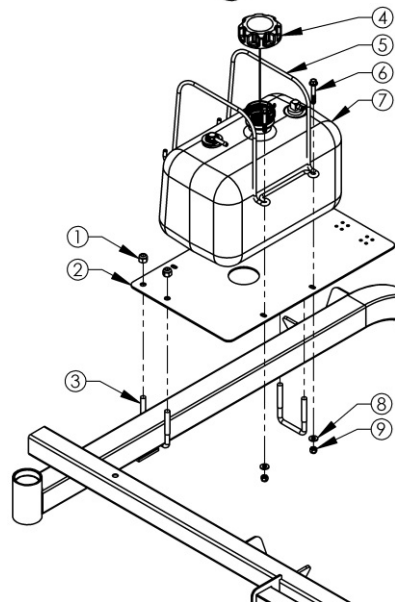
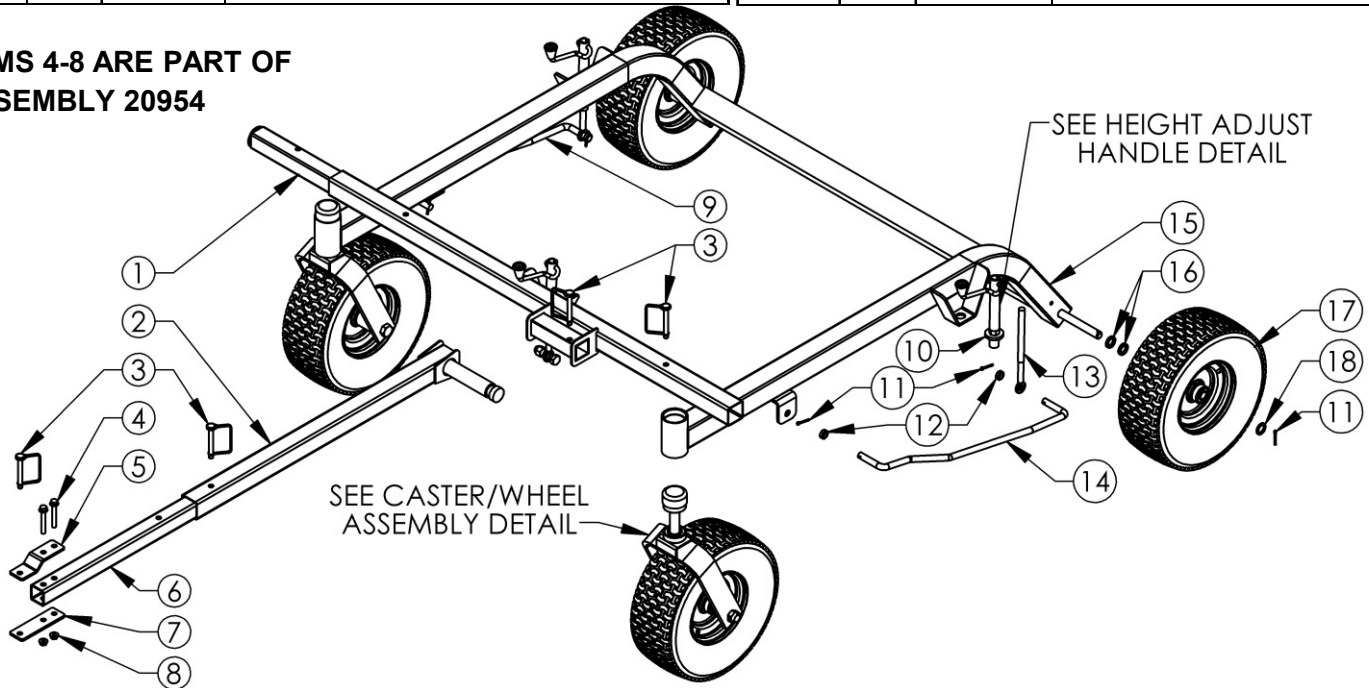

GAS TANK ASSEMBLY DETAIL

Parts Not Shown	
Part #	Description
11782	Line - Fuel, Bulk, 1/4" Low Perm
18232	Line - Fuel, Bulk, 3/16" Low Perm
18223	Clamp - Fuel
AS021	Tie, Black 5 1/2"

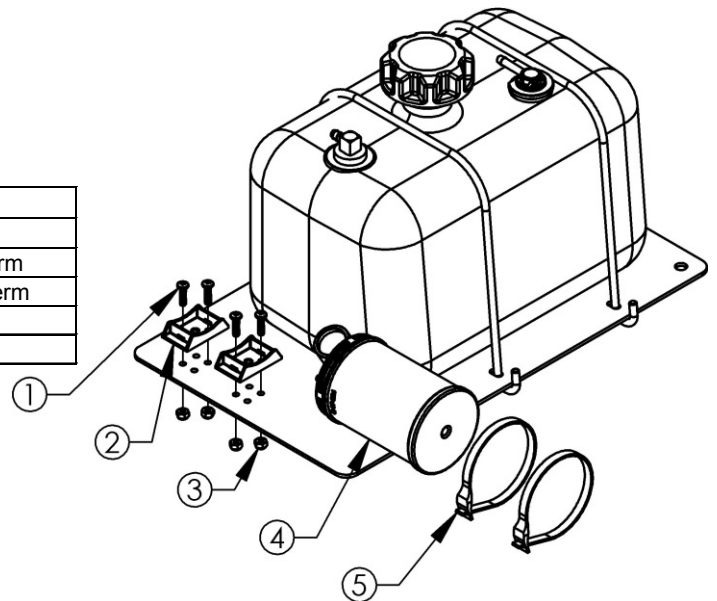

ONLY INCLUDED ON "CA" MODELS (CALIFORNIA COMPLIANT)

Item #	Qty	Description	Part #
1	4	Nut - Nyloc 3/8-16 ZY	NB182
2	1	Mount - For EPA/CARB Gas Tank	18331*
3	2	Ubolt - SQ , 3/8-16X2.437 X 3 Lg GR 5 ZY	12447
4	1	Cap, Fuel - 2.50 Gallon, Carb Sealed	18221
5	1	Bracket - Fuel Tank	18225
6	2	Bolt - Serr Flange 1/4-20 X 1 3/4 GR5 ZY	18236
7	1	Fuel Tank - 2.5 Gallon, Carb	18214
8	2	Washer - SAE Flat 1/4 ZY	NB274
9	2	Nut - Nylock 1/4-20	NB180

Item #	Qty	Description	Part #
1	4	Screw - 10-24 X 3/4 Phil Truss Head ZP	024203
2	2	Bracket - Carbon Canister, ZT	17127
3	4	Nut - 10-24 Nylon Lock	024900
4	1	Carbon Canister - 2.50 Gallon, 3/16 Line	18224
5	2	Cable Tie - Carbon Canister	18219

CENTER BLADE DRIVER DETAIL

Item #	Qty.	Description	Part #
1	4	Nut - Serr Flange, 1/4-20	NB524
2	2	Bearing - Blade	B98
3	1	Pulley - Blade, 5" A	20651
4	2	Washer - Belleville .773ID X 1.50OD	AS155
5	3	Washer - 3/4 ID X 1 1/4 OD	NB179
6	1	Spacer - 3/4ID X 1 1/2	6065PM
7	1	Blade - G6 Gator, 20.5"	20186
8	1	Nut - Jam 3/4-16	NB175
9	1	Plate - Blade Mount	9008
10	2	Nut - Lock, Two Way 3/8-24	NB216
11	2	Bolt - 3/8-24 X 1 1/4	NB166
12	1	Washer - Belleville .413IDX .945OD	NB607
13	1	Bolt - HHC 3/8-24 X 1	NB238N
14	1	Washer - Flat 3/4 ID X 1 3/4 OD	B98W
15	1	Housing - Cast Iron Blade Driver	19924
16	4	Bolt - Serr Flange, 1/4-20 X 1	13182
17	1	Shaft - Blade, 6.563	20656
18	1	Pulley - Blade, 5.5" A/B	21893

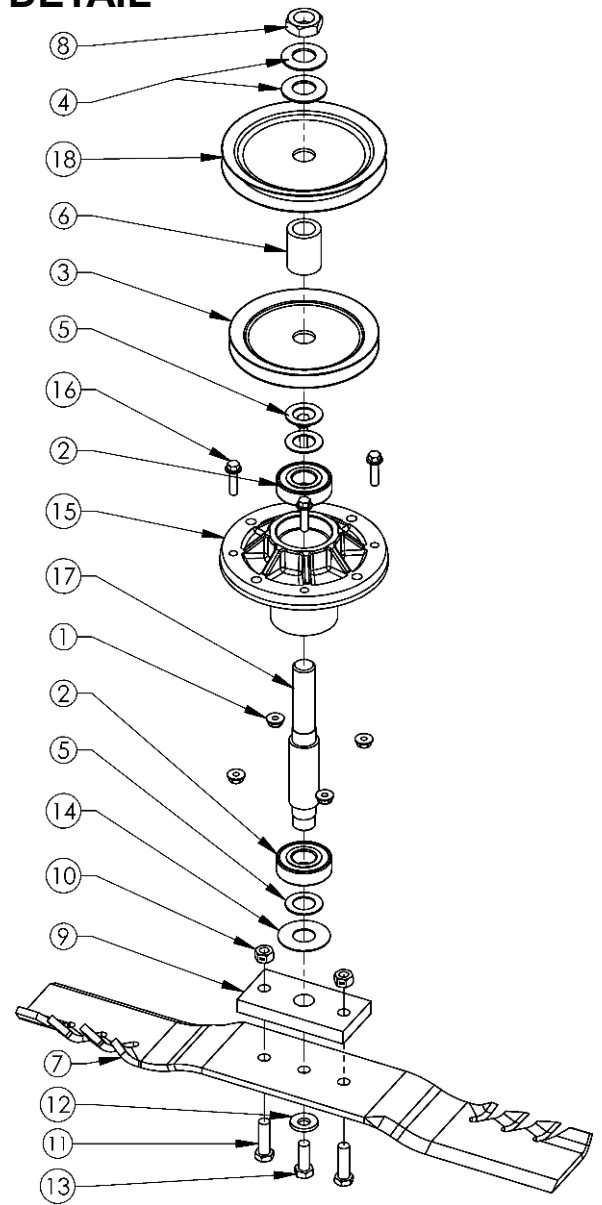

Recommended Torque Specifications	
Part No.	Torque (ft-lbs)
NB175	90
NB238N	35
NB524	20
NB216	35

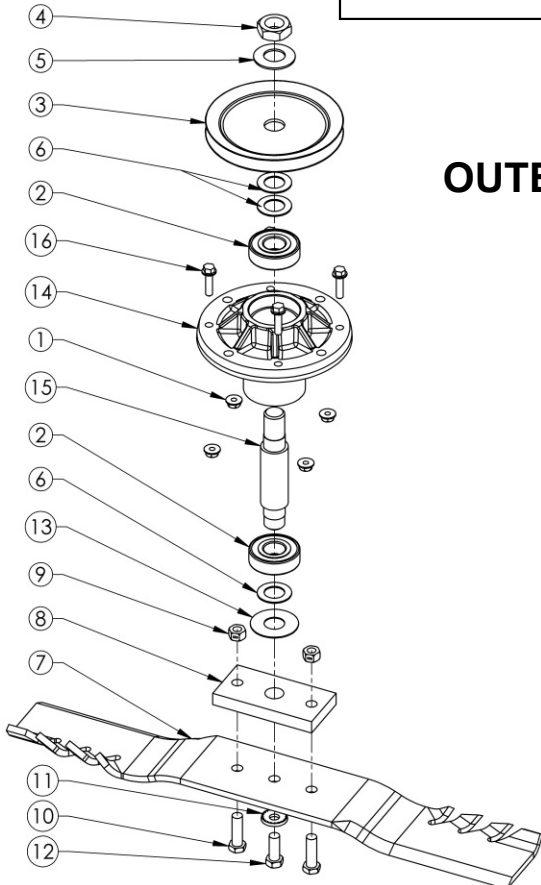

OUTER BLADE DRIVER DETAIL

Item #	Qty.	Description	Part#
1	4	Nut - Serr Flange, 1/4-20	NB524
2	2	Bearing - Blade	B98
3	1	Pulley - Blade, 5" A	20651
4	1	Nut - Jam 3/4-16	NB175
5	1	Washer - Belleville .773ID X 1.50OD	AS155
6	3	Washer - 3/4 ID X 1 1/4 OD	NB179
7	1	Blade - G6 Gator, 20.5"	20186
8	1	Plate - Blade Mount	9008
9	2	Nut - Lock, Two Way 3/8-24	NB216
10	2	Bolt - 3/8-24 X 1 1/4	NB166
11	1	Washer - Belleville .413IDX .945OD	NB607
12	1	Bolt - HHC 3/8-24 X 1	NB238N
13	1	Washer - Flat 3/4 ID X 1 3/4 OD	B98W
14	1	Housing - Cast Iron Blade Driver	19924
15	1	Shaft - Blade 5"	9077
16	4	Bolt - Serr Flange, 1/4-20 X 1	13182

When ordering replacement parts

*USE PAINT CODE: GT=GRAY TK=BLACK

MOWER DECK DETAIL

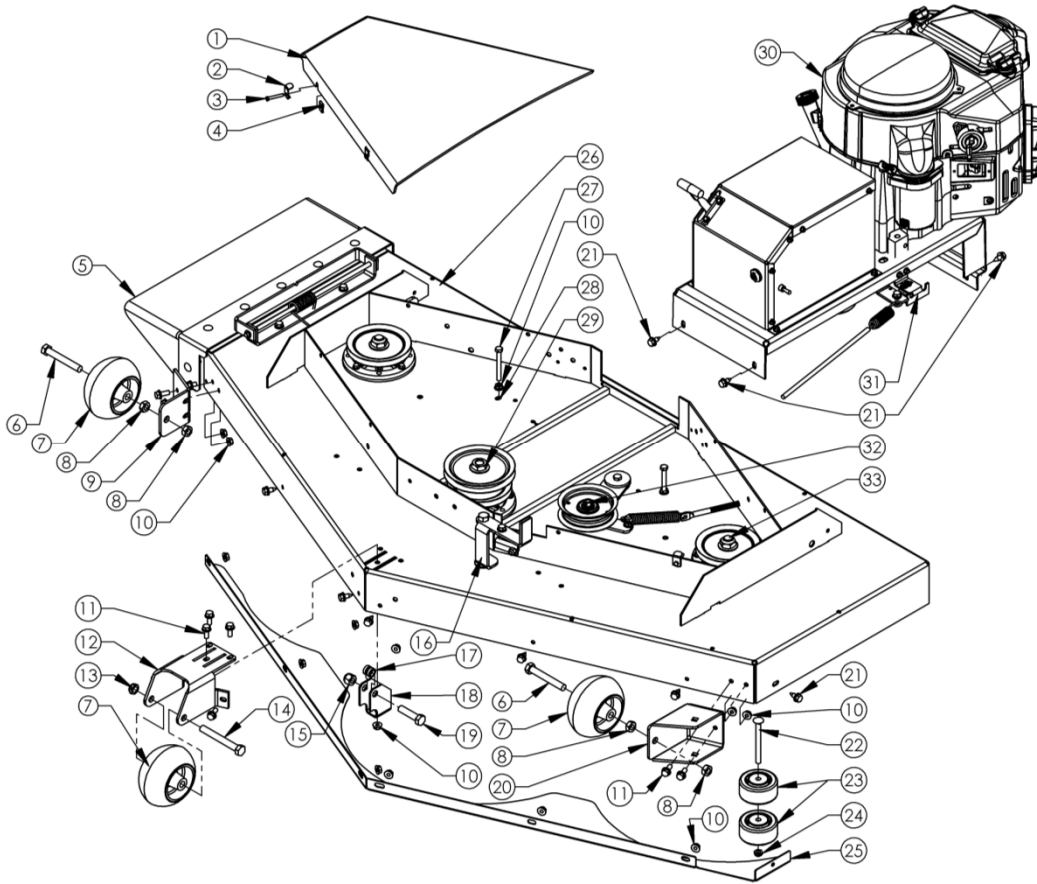

ITEM #	QTY	PART NO	DESCRIPTION
1	2	18391	Cover - Belt, Black Composite
2	8	18531	Washer - Bent .25" ID X 18GA
3	8	NB703	Screw - MSC, 10-24 X 1 1/4
4	8	18532	Nut - Clip, 10-24
5	1	--	See Grass Chute Asy Detail
6	2	NB577	Bolt - 1/2-13 X 3 1/2
7	3	3511	Wheel - Gauge
8	4	NB121	Nut - Jam Lock 1/2-13 2-Way
9	1	15780*	Bracket - Wheel Right
10	17	NB170	Nut - Serr Flange 5/16-18 Z
11	9	NB596	Bolt - Serr Flange 5/16-18 X 3/4
12	1	18383*	Bracket - Middle Roller
13	1	NB688	Nut - Nyloc Jam, 1/2-13 ZY
14	1	NB132	Bolt - 1/2-13 X 4 HCC
15	1	NB281	Nut - Nyloc 1/2-13 ZY
16	1	--	See Engage Lever Detail
17	2	T2PB	Bushing - Plastic
18	1	18384*	Bracket - Deck Hanger
19	1	NB509	Bolt - 1/2-13 X 2 HCC
20	1	15779*	Bracket - Left Wheel
21	9	26X249	Screw - .312-18X.75
22	1	NB707	Bolt - Carriage 3/8-16X4
23	2	AS001	Roller - Anti-Scalp 3/8 ID
24	1	NB207	Nut - Nyloc 3/8-16
25	1	21096*	Shield - Debris
26	1	18382*	Weldment - Deck
27	2	NB106	Bolt - 5/16-18 X 2 3/4 HCC
28	2	NB181	Nut - Nyloc 5/16-18
29	1	--	See Center Blade Driver Detail
30	1	--	See Motor Base Detail
31	1	--	See Safety Switch Bracket Detail
32	1	--	See Idler Detail
33	2	--	See Outer Blade Driver Detail

GRASS CHUTE ASSEMBLY DETAIL

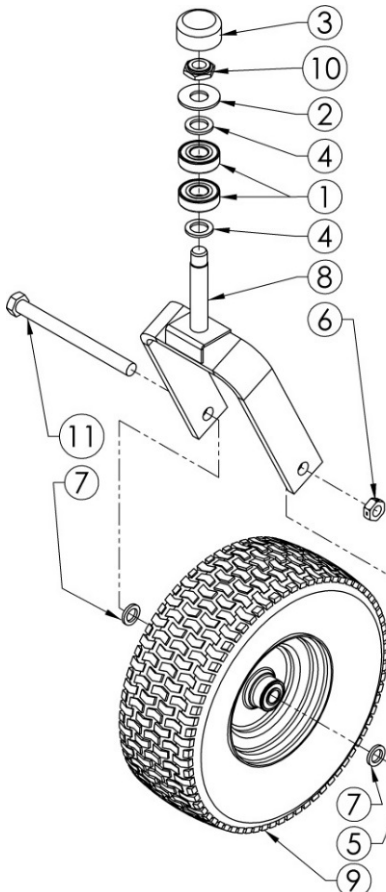

ITEM #	QTY	PART NO	DESCRIPTION
1	1	18702*	Weldment - Grass Chute
2	7	10501	Bolt - Carriage 3/8-16 X 1 1/4
3	1	18604	Rubber - Grass Chute
4	7	NB272	Washer - SAE Flat 3/8
5	7	NB182	Nut - Nyloc 3/8-16
6	1	18652*	Bracket - Grass Chute
7	2	26X249	Screw - .312-18 X .75
8	1	18654*	Bracket - Grass Chute Mount
9	1	18595	Rod - Deck, Grass Chute
10	1	166X34	Spring - Torsion
11	2	NB117	Nut - Push, 5/16

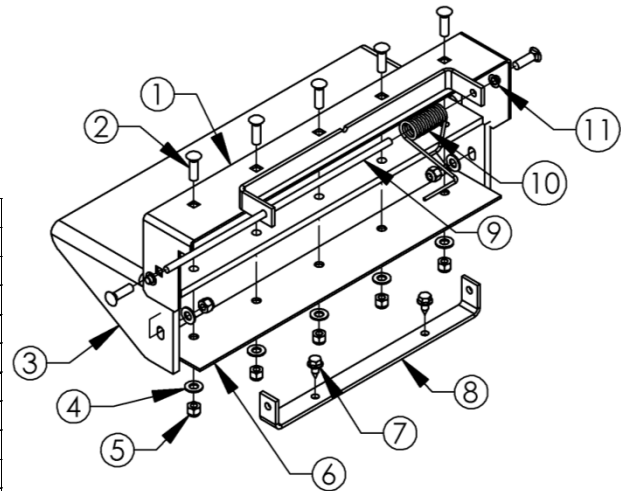

CASTER / WHEEL ASSEMBLY DETAIL

ITEM #	QTY.	PART NO.	DESCRIPTION
1	2	B98	Bearing
2	1	17X195	Washer - Flat
3	1	094618	Cap
4	2	NB195	Washer - 13/16 ID X 1 1/4 OD X 1/8
5	1	663L	Spacer
6	1	NB595	Nut - Locking Jam, 2 Way 5/8-11
7	2	NB178	Washer - 5/8 ID X 1 OD 10 GA
8	1	665*	Weldment - Caster
9	1	F4157WK	Tire/Wheel - 5/8 Bearing 13x5x6 NHS, Blk
10	1	NB122	Nut - Nyloc Jam 3/4-16
11	1	NB624	Bolt - 5/8"-16 X 7" HCC ZY Grade 5

MOTOR BASE DETAIL

PARTS NOT SHOWN

20899	Harness - Wiring
BCSR	Cable - Battery (10' Red)
BCLB	Cable - Battery (19 1/2" or 20" Black)
KSK	Keys - For Key Switch (set of two)
BCBT	Boot - Rubber, Small, Battery Cable

Slide plastic tube snug against toggle switch.

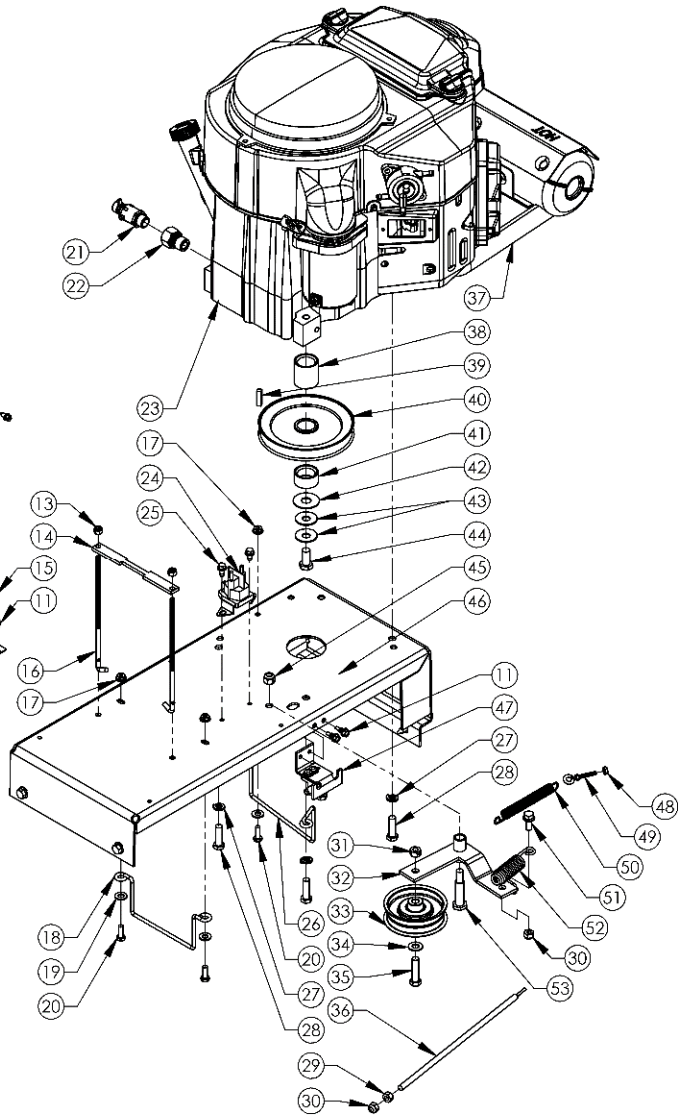
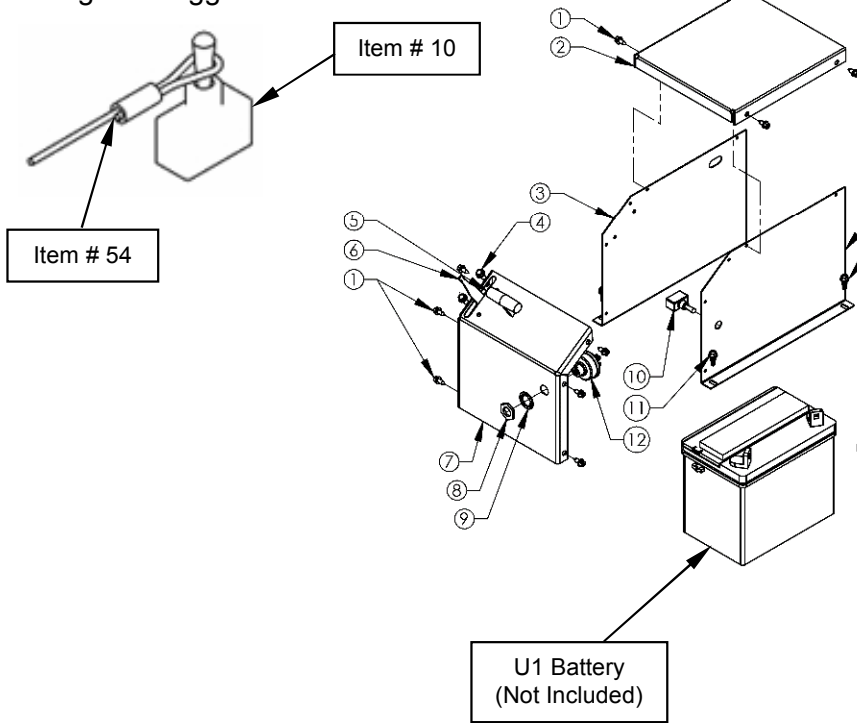

ITEM #	QTY.	PART NO.	DESCRIPTION
1	10	024206	Screw - 12 X 1/2 Hex Self Tap
2	1	17840*	Cover - Battery Top
3	1	17616*	Cover - Battery Right
4	2	26X263	Screw - TCS 1/4-20 X 5/8
5	1	4226K	Knob - T, For Throttle Cable
6	1	20916	Cable - Throttle
7	1	17614*	Cover - Battery Top Front
8	1	9087	Nut - Key Switch
9	1	9088	Washer - Lock, Key Switch
10	1	6855P	Switch - Toggle, Single Pole
11	6	NB161	Screw - HX Tek 1/4 X 3/4 ZP
12	1	3623	Switch - Key
13	2	NB180	Nut - Nylock 1/4-20
14	1	17794*	Bracket - Battery Hold Down
15	1	17615*	Cover - Battery Left
16	2	17760	Bolt-L
17	3	NB524	Nut - Serr Flange, 1/4-20 Grade 5
18	1	14869	Guide - Belt; T60
19	3	NB275	Washer - SAE Flat 5/16
20	3	NB250	Bolt - 1/4-20 X 3/4 GR5
21	1	16000	Valve - Oil Drain
22	1	18810	Adapter - Oil Drain, Kawasaki
23	1	N/A	Engine (Reference Model Shown)
24	1	1002004	Solenoid - 3 Pole
25	2	NB114	Bolt - TCS 1/4-20 X 1/2
26	1	20935	Guide - Belt, FC
27	4	NB711	Washer - Split Lock, 3/8 ZY, Medium

ITEM #	QTY.	PART NO.	DESCRIPTION
28	4	NB618	Bolt - 3/8-16 X 1 1/4 GR5 ZY
29	1	NB210Z	Nut - 5/16-18 HNC
30	2	NB181	Nut - Nyloc 5/16-18
31	1	NB280	Nut - 2 Way Lock 3/8-16 Wax Gr A
32	1	6009*	Idler - Engage Weldment
33	1	B527	Pulley - Idler, OD3.25" ID3/8"
34	1	NB272	Washer - SAE Flat 3/8
35	1	NB107	Bolt - 3/8-16 X 1 1/2 HCC GR5
36	1	10636YZ	Bolt - Spade, 5/16-18 X12
37	1	20919	Muffler - Kawasaki
38	1	689L	Spacer - Long, Engine Pulley, 1.5"
39	1	9031	Key Stock - 1/4 X 1 Undr Size
40	1	688	Pulley - Engine, 5.5"
41	1	689S	Spacer - Short, Engine Pulley, .687
42	1	TR150W	Washer - .531DX1 1/2ODX.062(Ht Trtd)
43	2	699	Washer - Belleville 7/16 X 1 1/4
44	1	NB452N	Bolt - 7/16-20 X 1 HCF GR5 Nylock
45	1	NB182	Nut - Nyloc 3/8-16
46	1	20904*	Motor Base - Weldment
47	1	--	See Safety Switch Detail
48	1	NB172	Nut - Kep 10-24 ZY
49	1	21894	Eyebolt - 10-24 X 1 3/8, w/ Nut
50	1	BRS6	Spring
51	1	NB596	Bolt - Serr Flange, 5/16-18 X 3/4
52	1	4422	Spring - Idler Tension, Bent Leg
53	1	NB220	Bolt - Shoulder 3/8-16X3/4 1/2X1-9/16
54	1	6736	Tether - Safety, Coiled

When ordering replacement parts

*USE PAINT CODE: GT=GRAY TK=BLACK

Engage Lever Detail

ITEM #	QTY.	PART #	DESCRIPTION
1	1	NB155	Bolt - 1/2-13 X 5 HCC GR5 ZP
2	1	21929*	Lever - Engage
3	2	NB121	Nut - 2 Way Lock 1/2-13 ZY
4	2	NB555	Washer - 1/2
5	1	NB253	Bolt - Serr Flng, 5/16-18 X1 1/4
6	1	2077	Pivot - Handle Grip
7	1	NB170	Nut - Serr Flng 5/16-18
8	1	11158	Nut - Jam, 2-Wy Lck, 5/16-18
9	1	4578*	Pivot - Engage
10	1	NB181	Nut - Nyloc 5/16-18

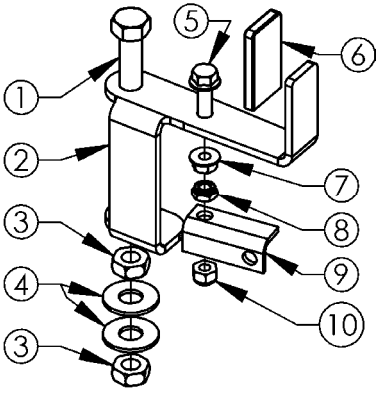

Height Adjust Handle Detail

ITEM #	QTY.	PART #	DESCRIPTION
1	1	H7N1TK**	Tube - Height Adjust
2	1	ES214**	Rod - Crank, For H7N
3	1	H7K**	Knob - Height Adjustment
4	2	NB117**	Nut - Push, 5/16
5	1	OD41**	Decal - Ruler

****Parts Included in Service Part # H7N**

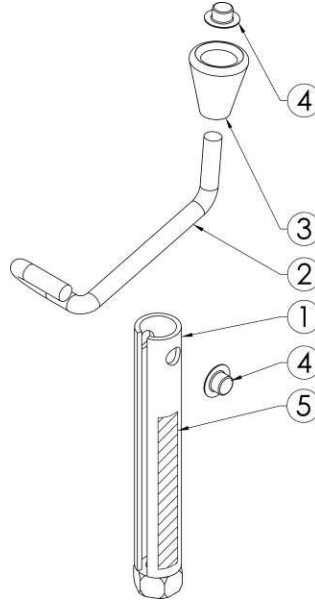

Safety Switch & Bracket Detail

ITEM #	QTY.	PART #	DESCRIPTION
1	1	18390*	Mount - Switch Safety
2	1	3695	Switch - Normally Closed
3	2	NB197	Screw - Phillips Truss 8-32 X 1/2
4	2	NB201	Nut - Kep 8-32

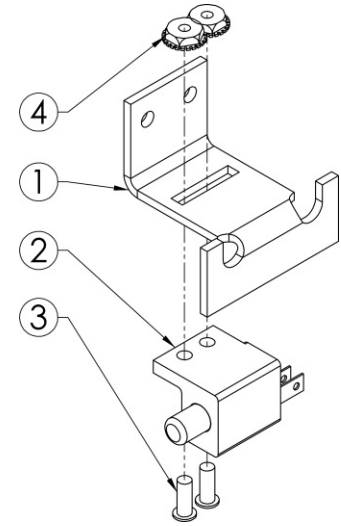

20946 Idler Detail

ITEM #	QTY.	PART #	DESCRIPTION
1	1	NB618	Bolt - 3/8-16 X 1 1/4 GR5
2	1	6040Z	Washer - Idler
3	1	6054*	Idler - Bottom
4	1	6037	Bushing - Idler
5	2	NB182	Nut - Nyloc 3/8-16
6	1	NB280	Nut - 2 Way Lock 3/8-16 Gr A
7	1	NB272	Washer - SAE Flat 3/8
8	1	20183	Pulley - Idler, 1" X 4" X 3/8" ID
9	1	21288	Bolt - Spade, 3/8-16 X 6.5
10	1	NB181	Nut - Nyloc 5/16-18
11	1	21425	Spring - Extension
12	1	NB170	Nut - Serr Flange 5/16-18
13	1	NB501	Bolt - 5/16-18 X 1 GR5
14	1	NB107	Bolt - 3/8-16 X 1 1/2 GR5

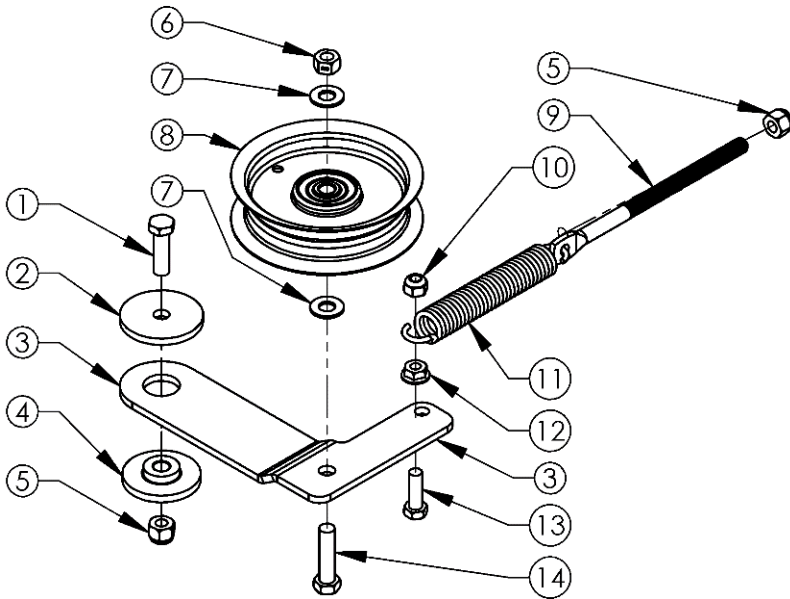

Belt Configuration

5058 Long Belt 6046HP Short Belt

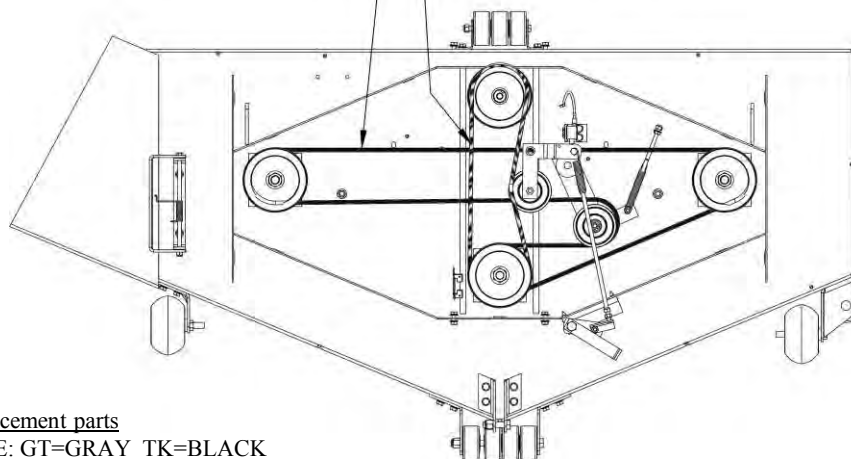

www.swisherinc.com

OWNER'S MANUAL

MODEL NO.

**FC14560CPKA
FC14560CPKA-CA**



IMPORTANT

Read and follow all
Safety Precautions
and Instructions
before operating this
equipment.

60" FAST FINISH TRAIL MOWER COMMERCIAL PRO

HOW TO ORDER

REPAIR PARTS:

Each mower has its own model number. Each engine has its own model number. The model number for the mower will be found at the left rear of the unit on the belt cover skirt.

The model number for the engine will be found on the top of the blower fan housing.

All mower parts listed herein may be ordered directly from Swisher or your nearest Swisher dealer.

All engine parts may be ordered from the nearest dealer of the engine supplied with your mower.

Color cannot be guaranteed on service parts.

WHEN ORDERING PARTS, PLEASE HAVE THE
FOLLOWING INFORMATION AVAILABLE:

- * PRODUCT - FC60 FAST FINISH TRAIL MOWER
- * SERIAL NUMBER - _____
- * MODEL NUMBER - _____
- * ENGINE MODEL NUMBER - _____
- TYPE - _____
- * PART NUMBER
- * PART DESCRIPTION

TELEPHONE - 1-800-222-8183

FAX - 1-660-747-8650

SWISHER ACQUISITION INC.

1602 CORPORATE DRIVE
WARRENSBURG, MO 64093

SWISHER®

CHANGING YOUR LANDSCAPE SINCE 1945