

**BRIGGS & STRATTON®**

## Standby Generator 13kW

**en** Installation and Operation Manual

**fr** Manuel d'installation et d'utilisation

**es** Manual de instalación y operación

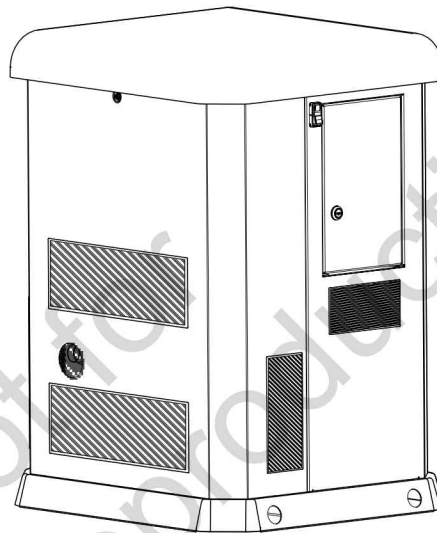

**en** This generator is rated in accordance with UL (Underwriters Laboratories) 2200 (stationary engine generator assemblies) and CSA (Canadian Standards Association) standard C22.2 N. 100-14 (motors and generators).

**es** Este grupo electrógeno está clasificado conforme a la norma UL (Underwriters Laboratories) 2200 (conjuntos de grupos electrógenos con motores fijos) y a la norma CSA (Canadian Standards Association) C22.2 N. 100-14 (motores y grupos electrógenos).

**fr** Ce groupe électrogène est certifié UL (Underwriters Laboratories) 2200 (groupes électrogènes à moteur fixe) et conforme à la norme CSA (Canadian Standards Association) C22.2 N. 100-14 (moteurs et groupes électrogènes).











# Table of Contents:

<b>Important Safety Instructions</b> .....	3	Fuel System Maintenance.....	31
<b>Safety Symbols and Meanings</b> .....	3	Mixer and Throttle Control Device.....	31
<b>Safety Alert Symbol and Signal Words</b> .....	3	Alarms (Service Code Detection System).....	31
<b>Safety Messages</b> .....	3	Acknowledge and Reset the Alarms.....	31
<b>FCC Statement Part 15 to User</b> .....	4	Electrical System Maintenance.....	31
<b>General Information</b> .....	4	<b>Troubleshooting</b> .....	<b>34</b>
Thank You.....	4	Troubleshooting Table.....	34
Where to Find Us.....	4	<b>Wiring Diagram and Schematic</b> .....	<b>36</b>
For Future Reference.....	4	<b>Concrete Pad Specifications</b> .....	<b>37</b>
Equipment Description.....	5	<b>Specifications</b> .....	<b>38</b>
Product Use.....	5	Generator Specifications 13kW.....	38
Installer Responsibilities.....	5	Engine Specifications 13kW.....	38
Owner Responsibilities.....	5		
Installation Factors to Consider.....	5		
Delivery Inspection.....	5		
Shipment Contents.....	5		
<b>Installation</b> .....	<b>6</b>		
Generator Placement.....	6		
Cold Weather Kits.....	11		
Lift the Generator.....	11		
Anchor the Generator and Wind Ratings.....	11		
Electrical and Fuel Inlet Locations.....	11		
Access Panels: Installation and Removal.....	12		
Fuel Installation Plan.....	14		
Electrical Field Connections.....	17		
Engine Oil.....	21		
Battery.....	21		
System Controller.....	22		
Initial Start-Up (No Load).....	23		
<b>Operation</b> .....	<b>24</b>		
Features and Controls.....	24		
Important Owner's Considerations.....	25		
Automatic Operation Sequence.....	25		
Set the Exercise Timer.....	25		
<b>Maintenance</b> .....	<b>26</b>		
Servicing the System – Before and After.....	26		
Maintenance Schedule.....	27		
Generator Maintenance.....	27		
Clean the Generator.....	27		
Engine Maintenance.....	27		
Change the Oil and the Oil Filter.....	28		
Adjust Valve Clearance.....	28		
Electronic Governor System.....	29		
Electronic Governor Check.....	29		
Service the Spark Plugs.....	29		
Engine Air Cleaner.....	30		
Exhaust System Maintenance.....	30		

# Important Safety Instructions

**SAVE THESE INSTRUCTIONS** - This manual contains important instructions that must be read, understood, and obeyed during installation of generator kits and/or accessories.

## Safety Symbols and Meanings

Symbol	Meaning
	Safety alert symbol shows a possible personal injury hazard.
	Read Manual. Failure to obey warnings, instructions, installation manual, and Operator's Manual could result in death or serious injury.
	Explosion
	Electric Shock
	Auto-start
	Fire
	Chemical Burn
	Toxic Fume
	Eye Protection
	Hot Surface
	Rotating Parts

# Safety Alert Symbol and Signal Words



The safety alert symbol  identifies safety information about hazards that could result in personal injury. A signal word (**DANGER**, **WARNING**, or **CAUTION**) is used to indicate the likelihood and the potential severity of injury. In addition, a hazard symbol is used to represent the type of hazard.

**DANGER** indicates a hazard which, if not avoided, **will** result in death or serious injury.

**WARNING** indicates a hazard which, if not avoided, **could** result in death or serious injury.

**CAUTION** indicates a hazard which, if not avoided, **could** result in minor or moderate injury.

**NOTICE** indicates information considered important but not hazard-related.

## Safety Messages

**WARNING** 

This product can expose you to chemicals including used engine oil, which is known to the State of California to cause cancer, and carbon monoxide, which is known to the State of California to cause birth defects or other reproductive harm. For more information go to [www.P65Warnings.ca.gov](http://www.P65Warnings.ca.gov).

**WARNING** 

This product contains lead and lead compounds, known to the state of California to cause birth defects or other reproductive harm. Wash your hands after handling this product. Cancer and Reproductive Harm - [www.P65Warnings.ca.gov](http://www.P65Warnings.ca.gov).

**NOTICE:** Improper treatment of generator could damage it and shorten its life.

- Use generator only for intended uses. See *Product Use* section of this manual.
- If you have questions about the intended use, contact your authorized dealer.
- Operate the generator only on level surfaces.
- Adequate, unobstructed flow of cooling and ventilating air is critical for correct generator operation.
- The access panels/doors must be installed whenever the unit is running.
- DO NOT expose the generator to excessive moisture, dust, dirt, or corrosive vapor.
- Remain alert at all times while working on this equipment. Never work on the equipment when you are physically or mentally fatigued.
- DO NOT insert any objects through the cooling slots.
- DO NOT use the generator or any of its parts as a step. Stepping on the unit could cause stress and break parts. This may result in dangerous operating conditions from leaking exhaust gases, fuel leakage, oil leakage, etc.
- Shut off generator if:
  - electrical output is lost.
  - equipment sparks, smokes, or emits flames.
  - unit vibrates excessively or makes unusual noises.

## FCC Statement Part 15 to User

Pursuant to part 15.21 of the FCC Rules, you are cautioned that changes or modifications to the product not expressly approved by Briggs & Stratton could void your authority to operate the product.

This device complies with part 15 of the FCC Rules.

Operation is subject to the following two conditions: (1) This device may not cause harmful interference, and (2) this device must accept any interference received, including interference that may cause undesired operation.

This equipment has been tested and found to comply with the limits for a Class B digital device, pursuant to part 15 of the FCC Rules. These limits are designed to provide reasonable protection against harmful interference in a residential installation. This equipment generates, uses and can radiate radio frequency energy and, if not installed and used in accordance with the instructions, may cause harmful interference to radio communications. However, there is no guarantee that interference will not occur in a particular installation. If this equipment does cause harmful interference to radio or television reception, which can be determined by turning the equipment off and on, the user is encouraged to try to correct the interference by one or more of the following measures:

- Reorient or relocate the receiving antenna.
- Increase the separation between the equipment and receiver.
- Connect the equipment into an outlet on a circuit different from that to which the receiver is connected.

- Consult the dealer or an experienced radio/TV technician for help.

## General Information

For most applications, the *Installation and Operation Manual* contains the information necessary to correctly install, operate, and maintain the generator. Briggs & Stratton has made every effort to make sure that the information in this manual is accurate and current. Briggs & Stratton reserves the right to change, alter, or otherwise improve the product and this document at any time without prior notice.

## Thank You

Thank you for purchasing this quality-built Briggs & Stratton® generator. We are pleased that you have placed your confidence in the Briggs & Stratton brand. When operated and maintained according to the instructions in this manual, your generator can provide many years of dependable service. This manual contains safety information to make you aware of the hazards and risks associated with standby generators and how to avoid them.

**SAVE THESE INSTRUCTIONS.** This manual contains important instructions that users must obey during installation, operation, and maintenance of the generator and battery.

## Where to Find Us

You do not have to look far to find support and service for your equipment. There are many authorized service dealers worldwide that supply quality service. You can also contact Customer Service by phone at **800-732-2989** between 8:00 AM and 5:00 PM central time or click on "Dealer Locator" at [www.briggsandstratton.com](http://www.briggsandstratton.com), which will supply a list of authorized dealers.

## For Future Reference

Fill out the information that follows and keep it with your receipt. Have this information at hand if you need to contact your installer or authorized dealer regarding service or repair of the unit.

Date of Purchase: \_\_\_\_\_

Dealer/Retailer: \_\_\_\_\_

Dealer's/Retailer's Phone Number: \_\_\_\_\_

### GENERATOR:

Model Number: \_\_\_\_\_

Model Revision: \_\_\_\_\_

Serial Number: \_\_\_\_\_

### ENGINE:

Model Number: \_\_\_\_\_

Serial Number: \_\_\_\_\_

## Equipment Description

**NOTICE:** This product does NOT qualify for either an emergency standby or legally required standby system as defined by NFPA 70 (NEC).

- Emergency generator systems are intended to automatically supply illumination, power, or both, to designated areas and equipment in the event of failure of the normal supply. Emergency systems can also supply power for such functions as ventilation where essential to maintain life, where current interruption of the normal supply would produce serious life safety or health hazards.
- Legally required standby generator systems are intended to automatically supply power to selected loads in the event of failure of the normal source (which can create hazards or prevent rescue or fire-fighting operations).

## Product Use

This product is only for use as an optional generator system. It provides an alternate source of electric power and serves loads such as heating, refrigeration systems, and communication systems that, when stopped during a power outage, can cause discomfort or inconvenience.

Every effort has been made to make sure that the information in this manual is accurate and current. However, we reserve the right to change, alter, or otherwise improve the product and this document at any time without prior notice.

Only current licensed electrical and plumbing professionals can attempt generator system installations. Installations must obey all applicable codes, industry standards, laws and regulations.

## Installer Responsibilities

- Read and obey the safety, installation and operation instructions in this *Installation and Operation Manual*.
- Install only a Nationally Recognized Testing Laboratory (NRTL) approved transfer switch that is compatible with the generator.
- Installation must obey all applicable codes, industry standards, laws, and regulations.
- Allow sufficient room on all sides of the generator for maintenance and service.
- Speak with the owner about generator placement.
- Speak with the owner about carbon monoxide (CO) and smoke detectors. It is the owner's responsibility to have carbon monoxide and smoke detector(s) installed and maintained indoors according to the manufacturer's instructions and recommendations.
- Make sure that ALL of the manuals are given to the owner after the installation has been completed.

- The unit is to be installed so that the risk of contact by people is minimized.

## Owner Responsibilities

- Read and obey the instructions in this *Installation and Operation Manual*.
- Follow a regular maintenance schedule and use the generator as specified in this manual.
- Carbon monoxide detector(s) MUST be installed and maintained indoors according to the manufacturer's instructions and recommendations. Smoke alarms cannot detect carbon monoxide gas.
- Smoke detector(s) MUST be installed and maintained indoors according to the manufacturer's instructions and recommendations. Carbon monoxide alarms cannot detect smoke.

## Installation Factors to Consider

The illustrations shown in this manual are for typical circumstances. They are meant to familiarize you with the installation options available for the generator.

Federal and local codes, appearance, noise levels, fuel types, and distances are installation factors that must be considered. Remember that, as the distance increases from the existing electrical service and gaseous fuel supply, and the number of bends in the fuel supply increases, compensations must be made for piping and wiring materials. This is necessary to comply with local codes and overcome electrical voltage drops and gaseous fuel pressure drops.

## Delivery Inspection

Avoid damage from dropping, bumping, or collision with the shipping carton.

Remove the carton and carefully examine the generator for damage that can occur during shipment.

If an owner sees loss or damage at the time of delivery, the owner must tell the person or persons who made the delivery to document the loss or damage on the freight bill and affix a signature under the consignor's memo of loss or damage. If the owner notices loss or damage after delivery, separate the damaged materials and then contact the carrier for claim procedures. Missing or damaged parts are not warranted.

## Shipment Contents

**The generator system is supplied with:**

- Oil (5W30 Full Synthetic)
- Flexible fuel line
- Quick Operation Manual
- Product and emissions warranty booklet
- Two access keys
- Two 15 Amp ATO-type fuses
- Four lifting hole caps
- +12V battery terminal cover

### Not included (You will need):

- Carbon monoxide detector(s)
- Smoke detector(s)
- Starting battery
- Connecting wire and conduit
- Fuel supply valves/plumbing
- Crane, lifting straps, chains or cables
- Two 60" (152cm) lengths of 3/4" (1.9cm) nominal minimum Schedule 40 steel pipe (NOT conduit)
- Torque screwdriver, 5 to 50 inch-pound range
- Multi-meter

## Installation



### WARNING

Generator and utility voltage could cause electrical shock or burn resulting in death or serious injury.

- Installation must be performed by a licensed professional.
- Disconnect all sources of electricity before installing or servicing equipment.
- Ground system before applying power.



### WARNING

Hazardous Voltage - Installing low and high voltage wire in same conduit could cause electric shock or burns, resulting in death or serious injury.

- Do not run low and high voltage wire in the same conduit unless the insulation rating on ALL wiring is rated for 600 V. See NFPA 70 for more information.

Only current licensed electrical professionals are qualified to do system installations. Installations must obey all related codes, industry standards and regulations. The equipment warranty is VOID unless the system is installed by licensed electrical professionals.

**NOTICE** Disconnect all power connections before you install this equipment. Failure to do so could cause internal damage to the board during electrical connections.

Incorrect installation can cause damage to the circuit boards and shorten their life. If you install the circuit boards in live circuits it will damage the board, which is not included in the warranty. ALWAYS disconnect ALL sources of power before you service the generator.

All wiring must be the correct gauge, correctly supported and protected by conduit. All wiring must be done as specified by federal, state and local codes, standards and regulations. Obey the wire type and torque specifications printed on the terminal blocks, neutral/ground connectors, and installation instructions. Use the installer supplied 600VAC or greater copper or aluminum wire of a gauge that complies with the latest version of the National Electric Code to complete the connections between utility power, transfer switch, generator,

main distribution panel, and optional remote modules. Apply the necessary correction factors and wire size calculations.

1. Set the Generator Circuit Breaker to the OFF position.
2. Set the Generator ON/OFF Switch to the OFF position.
3. Remove the 15 Amp fuse from the generator.
4. Disconnect the utility power to the generator and transfer switch.

## Generator Placement

Before the generator is installed, speak with the owner and convey the requirements that follow. They must be satisfied before the installation is complete.

The owner must be told about two equally important safety concerns:

- Carbon monoxide poisoning
- Fire

An installer must meet several other general location guidelines that are contained in this manual before the installation is complete.



### WARNING

Engine exhaust contains carbon monoxide, a poisonous gas that could kill you in minutes. You cannot smell it, see it, or taste it. Even if you do not smell exhaust fumes, you could still be exposed to carbon monoxide gas.

- Operate this product ONLY outdoors in an area that will not accumulate deadly exhaust gas.
- Direct exhaust gas away from any windows, doors, ventilation intakes, soffit vents, crawl spaces, open garage doors or other openings that can allow exhaust gas to enter inside or be drawn into a potentially occupied building or structure.
- Carbon monoxide detector(s) MUST be installed and maintained indoors according to the manufacturer's instructions/recommendations. Smoke alarms cannot detect carbon monoxide gas.
- If you start to feel sick, dizzy, weak, or your carbon monoxide alarm sounds while using this product, get to fresh air right away. Call emergency services. You may have carbon monoxide poisoning.
- DO NOT run this product inside homes, garages, basements, crawlspaces, sheds, or other partially-enclosed spaces even if using fans or opening doors and windows for ventilation. Carbon monoxide can quickly build up in these spaces and can linger for hours, even after this product has shut off.

1

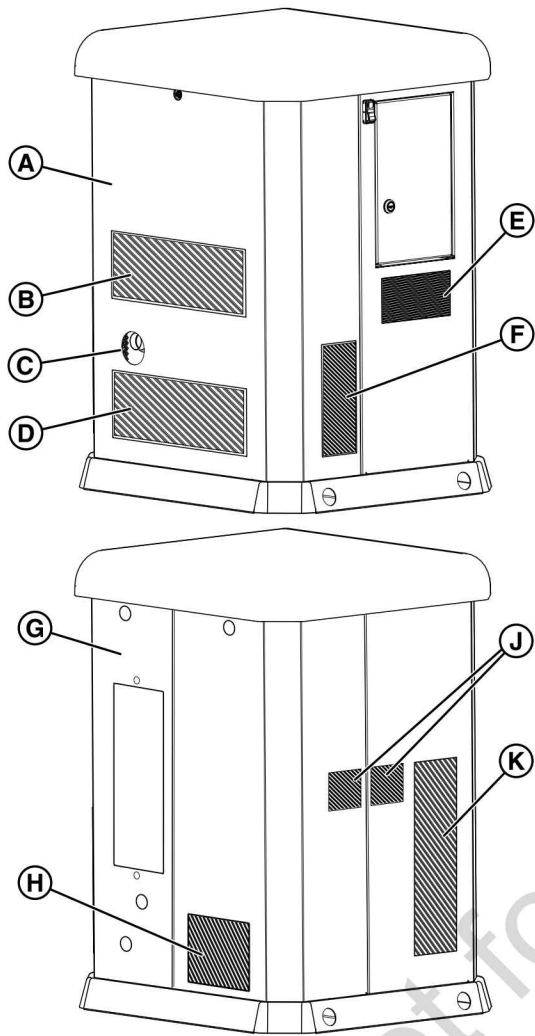

- (A) Front side of enclosure
- (B, D, F, J and K) Neutral air exchange ducts
- (C) Exhaust outlet
- (E) Engine intake duct
- (G) Back side of enclosure
- (H) Alternator inlet duct

## Generator Location Considerations

The installation location of the generator directly effects:

1. The amount and size of the plumbing required to fuel the generator.
2. The amount and size of the wiring required to control and connect the generator.
3. The safety of the installation regarding exhaust gas and carbon monoxide hazards, fire risks, proximity to other utilities, and exposure to weather elements.

The *Generator Placement* section addresses specific location guidelines. The owner and installer must speak to one another to determine how the site can affect installation costs and compliance with local codes and standards.

## Federal and International Standards

Generator installation must strictly adhere to ICC, IFGC, NFPA 37, NFPA 54, NFPA 58, and NFPA 70 standards.

National Fire Protection Association (NFPA) 37: This standard addresses the installation and use of stationary combustion engines. Its requirements describe keeping an enclosed generator a specific distance from a structure or wall. This standard also requires that when you locate a generator, you provide adequate space to perform maintenance and repair tasks and space for the maneuvering of first responders.

NFPA 37, Section 4.1.4, Engines Located Outdoors: This requirement specifies that engines and their weatherproof housings (if provided) installed outdoors must remain at least 5 ft (1.52 m) from openings in walls and at least 5 ft (1.52 m) from structures with combustible walls. The standard does not require a minimum separation if either of the following conditions exist:

1. The structure's adjacent wall has a fire-resistance rating of at least one hour.
2. Where a fire test involving consumption of the available combustibles, within the engine or, if provided, its weatherproof housing demonstrates that a fire originating at the engine or its weatherproof housing will not ignite combustible structures.

## Annex A—Explanatory Material

A4.1.4 (2): This requirement means that demonstrating compliance involves conducting a full-scale fire test or by following the calculation procedures found in Chapter 10 of NFPA 555.

This requirement concludes that due to the limited space frequently available for installation of the unit, exception (2) is beneficial for many residential and commercial installations. The manufacturer has contracted with an independent testing laboratory to conduct full-scale fire tests.

The ultimate goal of the fire testing was to evaluate the absolute worst fire scenario within the generator and to determine the ignition risk for items outside the engine enclosure at specific distances. Note that the enclosure is constructed of non-combustible materials. Outcomes from independent lab tests showed that a fire that started within the generator enclosure would not pose an ignitability risk to nearby combustibles or structures for at least one hour.

Combining results from these full-scale tests and the requirements of NFPA 37, Sec 4.1.4, the guidelines for installation of the generators previously mentioned change to 18 in (45.7 cm) from the back side of the generator to a stationary wall or building. For more information see *Distance Requirements* section in this manual.

## Reduce the Risk of Carbon Monoxide Poisoning

In high concentrations, carbon monoxide (CO) can be fatal in minutes. However, the effects of lower concentrations can also be lethal. This gas poses serious dangers to humans

and their animals because no one can smell, see, or taste it. Symptoms of exposure to CO include:

- Watery, itchy eyes
- Throbbing temples
- Inability to think coherently
- Ringing in the ears
- Headache
- Incoherent or slurred speech
- Flushed appearance
- Inattentiveness
- Loss of physical coordination
- Tightness across the chest
- Drowsiness
- Nausea
- Dizziness
- Vomiting
- Fatigue
- Collapse
- Convulsions

If you (or someone nearby) suffers from any of the above symptoms, immediately seek fresh air and call for emergency medical help for possible carbon monoxide poisoning. If your carbon monoxide alarm sounds while using this product, immediately seek fresh air (even if you experience none of the previously mentioned symptoms).

### **Carbon Monoxide (CO) Detectors**

**NOTICE:** Installing functioning CO alarms indoors is the only way to recognize CO gas. Common smoke alarms do not detect CO gas and will not alert occupants of its presence.

A CO detector is an electronic device that detects hazardous levels of CO. When a buildup of CO occurs, the detector will alert the occupants by sounding an alarm and by flashing a visual indicator light.

By law many states require a home to have a functioning carbon monoxide (CO) detector. The installer must speak

with the owner about carbon monoxide (CO) detectors. Carbon monoxide detector(s) MUST be installed and maintained indoors according to the manufacturer's instructions and recommendations. Smoke alarms cannot detect carbon monoxide gas.

Contact the local building inspection division for any relevant requirements regarding the use of CO detectors. See National Fire Alarm and Signaling Code (NFPA) 72 Code and Section R315 in the International Residential Code (ICC) for additional details.

### **Potential Carbon Monoxide Entry Points**

#### **Operation Guidelines:**

**NOTICE:** Operate this product only outdoors and in an area that will not allow this deadly exhaust gas to collect.

Never operate this product inside homes, garages, basements, crawl spaces, sheds, under a deck, or other partially enclosed areas and understand that using fans and opening doors in these areas may not provide adequate ventilation. Carbon monoxide can quickly accumulate in these forbidden spaces and can remain in the air for several hours after this product has shut off.

#### **Installation Guidelines:**

Follow all instructions and illustrations in this manual when placing an enclosure.

Always point the generator's engine exhaust away from occupied areas. Never expose your neighbors' homes to the engine exhaust flowing from your standby generator during the installation process.

Never place the standby generator in any area where leaves or debris can accumulate.

Generator exhaust can enter through windows, doors, and other openings of a structure. Understand that exhaust and CO can seep into a structure through the smallest openings.



## Protecting the Structure

Examine the structure to make sure that the sealing and caulking is sufficient enough to prevent air from leaking in or out. Examine the structure for voids, cracks, or openings surrounding windows, doors, soffits, pipes, and vents, as these areas can permit exhaust gas and Carbon Monoxide (CO) to enter the structure.

2

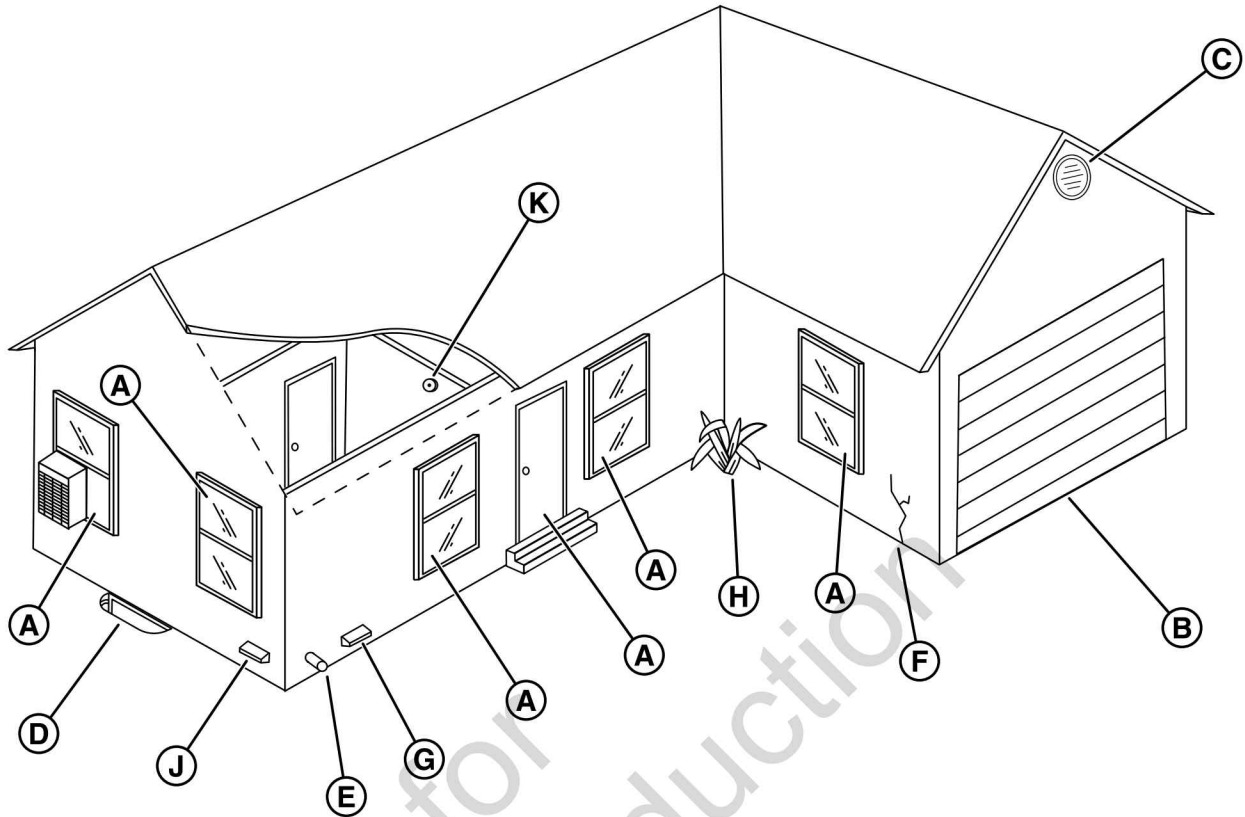

The table that follows includes examples of potential entry points for CO gas.

LOCATION	ENTRY POINT	EXPLANATION
A	Windows and doors	Openings that are part of a structure's architecture can permit fresh air and CO into the structure, especially when open.
B	Garage door	An open or improperly unsealed garage door can allow CO to flow into a garage.
C	Attic vent	Generator exhaust can enter through attic vents and the vents for soffits, crawl spaces, and ridges or roofs.
D	Basement windows	Basement windows or hatches that permit ventilation to or from the structure's lower level also allow CO gas to enter the structure.
E	Furnace intake or exhaust vent	Air intakes and furnace exhaust pipes are common entry points for CO gas.
F	Wall cracks	Any cracks in a structure's walls, including the foundation and mortar, and any gaps around windows, doors, and pipes can let CO in.
G	Dryer vent	Sometimes the exhaust vent for the clothes dryer lets CO gas into the structure.
H	Airflow restrictions	Areas featuring structural corners and heavy vegetation restrict the airflow and collect exhaust gas.
J	Makeup air system	Note: Keep all mechanical and gravity outdoor air intake openings for HVAC supply air systems 10 ft (3 m) horizontally from the generator's enclosure. Refer to section 401 in the ICC Mechanical Code for details on requirements.
K	Carbon monoxide detector(s)	Note: Installing functioning CO alarms indoors is the only way to recognize CO gas. Common smoke alarms do not detect CO gas and will not alert occupants of its presence.

## Reducing the Risk of Fire



Exhaust heat/gases could ignite combustibles causing a fire, resulting in death or serious injury.

- Remove all combustible materials from in and around the generator compartment.

To help prevent fires, the generator must be installed a safe distance from all combustible materials. The unit's engine, alternator, and exhaust system components can become very hot during operation. Reduce the likelihood of a fire by keeping the unit properly ventilated, properly maintained, free of fuel leaks, and away from combustible materials. Also, flammable debris may collect within or outside the generator enclosure and may possibly ignite, causing a fire.

### Distance Requirements

An owner must maintain minimum clearances around the generator enclosure. These clearances exist primarily for fire prevention, but they also make sure that adequate space for maintenance tasks, such as removing the unit's front, back, exhaust outlet side, and air inlet side panels.

3

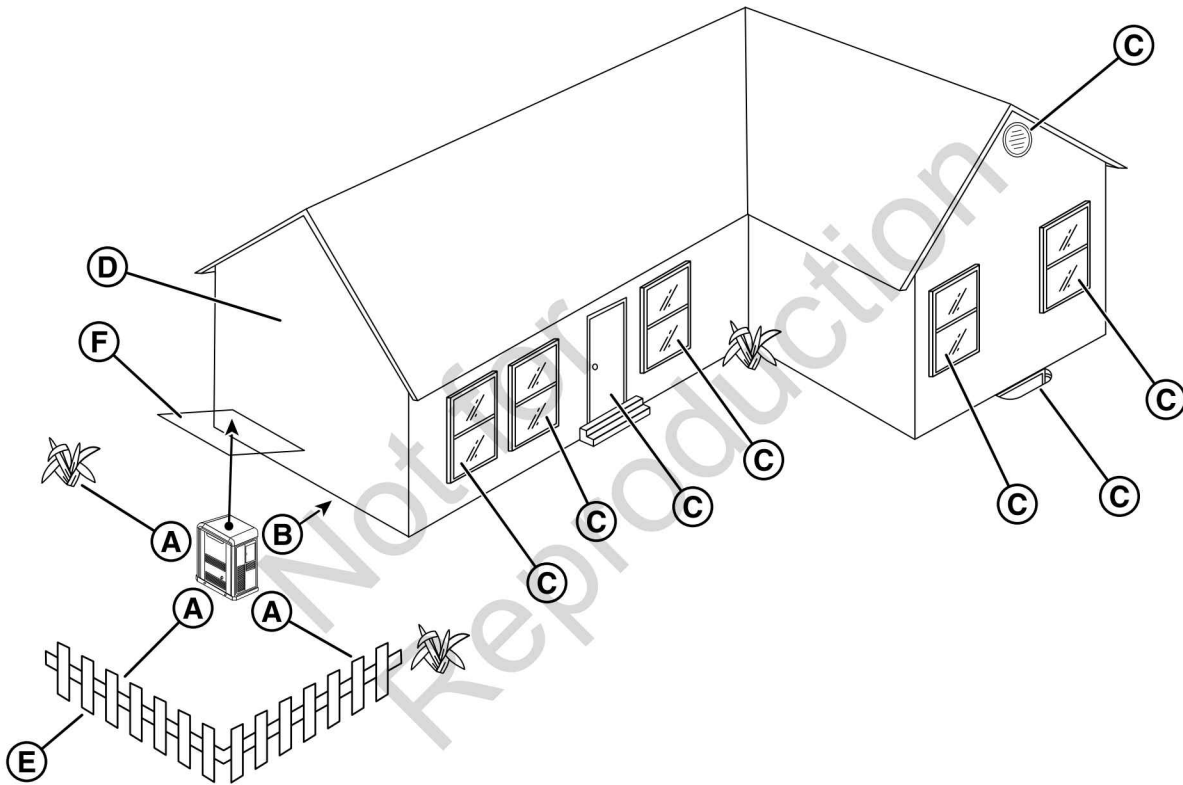

The table that follows explains the correct distances required for installation.

LOCATION	ITEM	EXPLANATION
A	Front and end clearance	Maintain a 3 ft (.91 m) minimum clearance from the front and ends of the generator. Keep shrubs, bushes, plants, and trees this same minimum distance from the unit and never use vegetation to conceal the unit.
B	Back clearance	Since fuel and electrical connections occur here, keep 18 in (45.7 cm) minimum clearance per independent testing laboratory, unless state codes tell you otherwise.
C	Windows, vents, and openings	Install the generator at least 5 ft (1.52 m) from all windows, doors, vents, window wells, or openings in the wall. See <i>Protecting the Structure</i> section in this manual.
D	Existing wall	Keep the generator at least 18 in (45.7 cm) away from existing walls.
E	Removable fence	Keep removable fences at least 3 ft (.91 m) away from the front of the generator. Removable fences include visual surrounds, fence panels, and temporary barriers without footings.
F	Overhead clearance	Maintain a 5 ft (1.52 m) minimum clearance from all structures, overhangs, projections on a wall, or trees.
G	Maintenance and servicing (not shown)	Allow adequate space to perform routine maintenance, such as servicing the engine and replacing the battery. Never use shrubs, bushes, trees, or plants to conceal the generator.

## Other General Location Guidelines

- Place the standby generator in a prepared location that is flat and has provisions for water drainage.
- Install the standby generator in a location where sump pump discharge, rain gutter down spouts, roof run-off, landscape irrigation, or water sprinklers will not flood the unit or spray the enclosure and enter any air inlet or outlet openings.
- Install the standby generator where it will not affect or obstruct any services (including covered, concealed and underground), such as telephone, electric, fuel (natural gas / LPG vapor), irrigation, air conditioning, cable, septic, sewer, well and so forth.
- Install the standby generator where leaves, grass, snow, etc will not obstruct air inlet and outlet openings. If prevailing winds will cause blowing or drifting, you may need to construct a windbreak to protect the unit.

## Cold Weather Kits

If the generator operates in temperatures below 30 °F (-1 °C), it is recommended that a Cold Weather Kit be installed.

Oil and Battery Warmer Kit, Part Number 6921, includes:

- Oil warmer
- Battery warmer
- Harness

Fuel Regulator Warmer Kit, Part Number 6845, includes:

- Regulator warmer
- Harness

Battery Warmer Kit, Part Number 6182, includes:

- Battery warmer
- Harness

Oil Warmer Kit, Part Number 6922, includes:

- Oil warmer
- Harness

These items are available at your local service dealer.

For more information, call 800-732-2989 between 8:00 AM and 5:00 PM CT.

## Lift the Generator



**WARNING** Hazardous Voltage - Contact with power lines could cause electric shock or burns, resulting in death or serious injury.

- If lifting or hoisting equipment is used, DO NOT contact any power lines.
- DO NOT lift or move generator without assistance.

Correct tools, equipment, and qualified personnel must be used in all phases of handling and moving the generator. The approximate weight of the generator is listed in the *Generator Specifications* section.

Use the lifting holes (A, Figure 4) in the base of the generator to lift the generator onto the concrete slab or pad. Lift the

generator in accordance with the Occupational Safety and Health Administration (OSHA) or local lifting regulations.

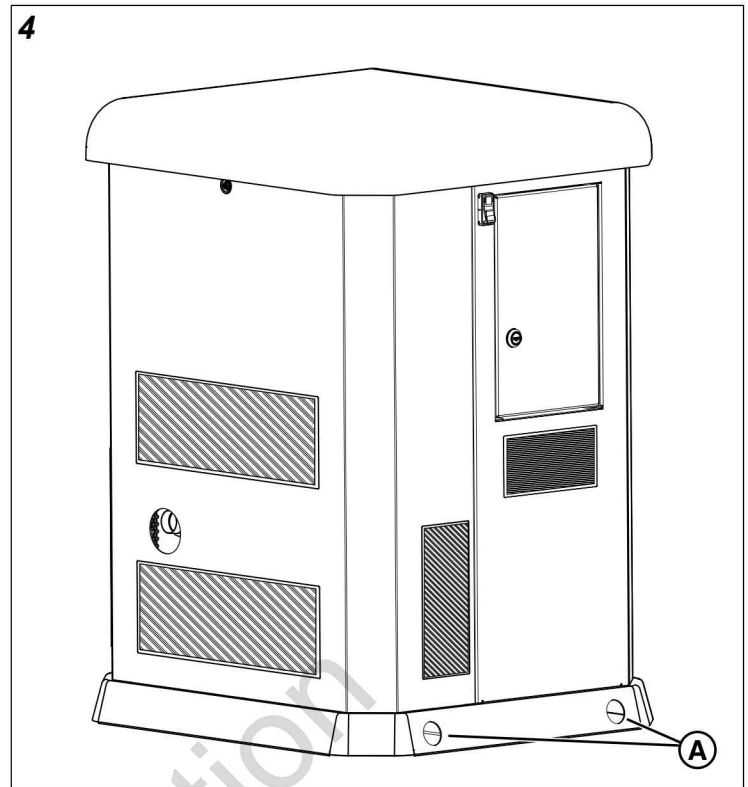

## Anchor the Generator and Wind Ratings

Unless mandated by local or state codes, or required to achieve wind rating, a concrete pad is not required for anchoring the generator. For concrete pad mounting and wind rating details, reference the *Anchoring and Wind Rating Diagram* at the end of this manual.

## Electrical and Fuel Inlet Locations

The 3/4 inch N.P.T. fuel inlet connector (A, Figure 5) and electrical inlet locations (B) are shown below.

The 1/2 inch knock-out is provided for the electrical inlet. This inlet may be enlarged or supplemented to accommodate a maximum conduit size of 1-1/2 inches. Make sure that the installed conduit(s) enter the unit in zone (C) as shown in the drawing that follows so that they enter the electrical box correctly.

5

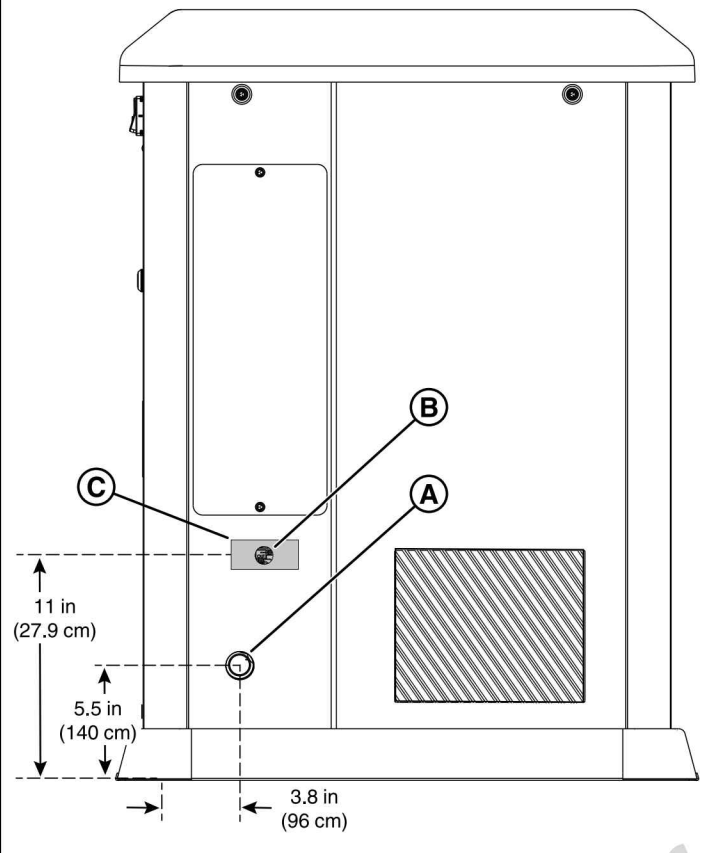

## Access Panels: Installation and Removal

The generator is equipped with an enclosure that has multiple access panels, as shown in the images that follow.

Each access panel and the roof are used to access:

- Battery Compartment
- Engine Oil Drain Hose
- Engine Oil Filter
- Engine Valve Cover
- Spark Plugs

Each generator is shipped with a set of identical keys attached to one of the panels.

### Roof – Installation and Removal (Figure 6):

1. Install or remove the roof, carefully, with the screws (A) that attach the roof to the unit.

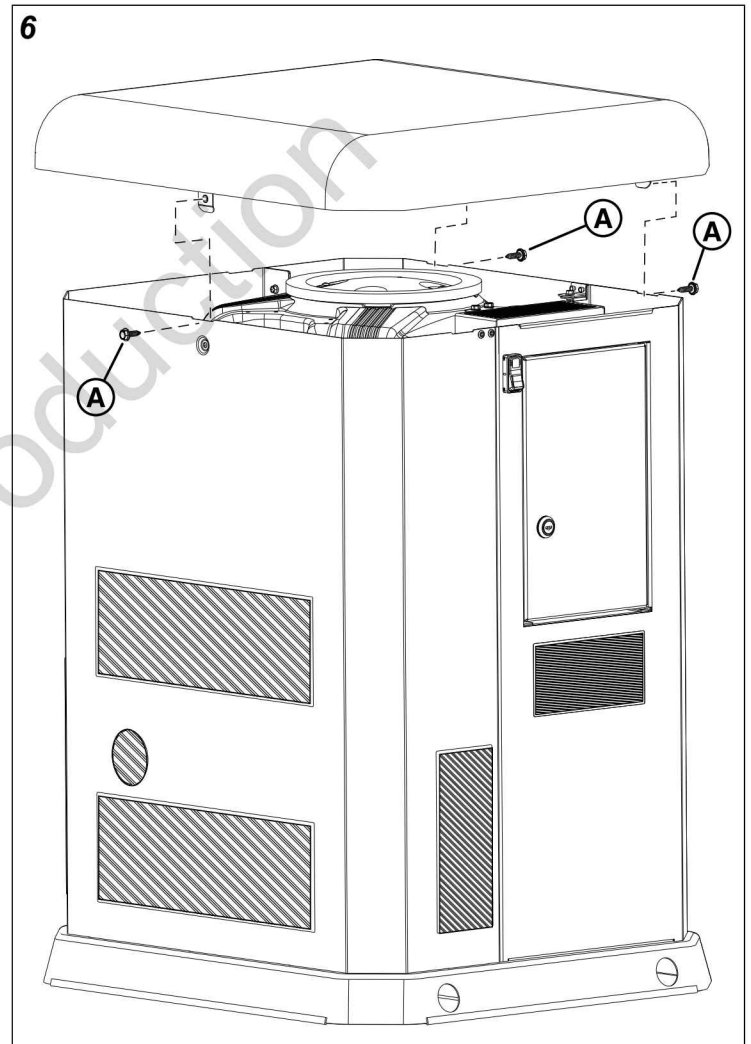

## Front Panel – Installation and Removal (Figure 7):

1. Install or remove the front panel, carefully, with the two fasteners (A) that attach the panel to the unit.

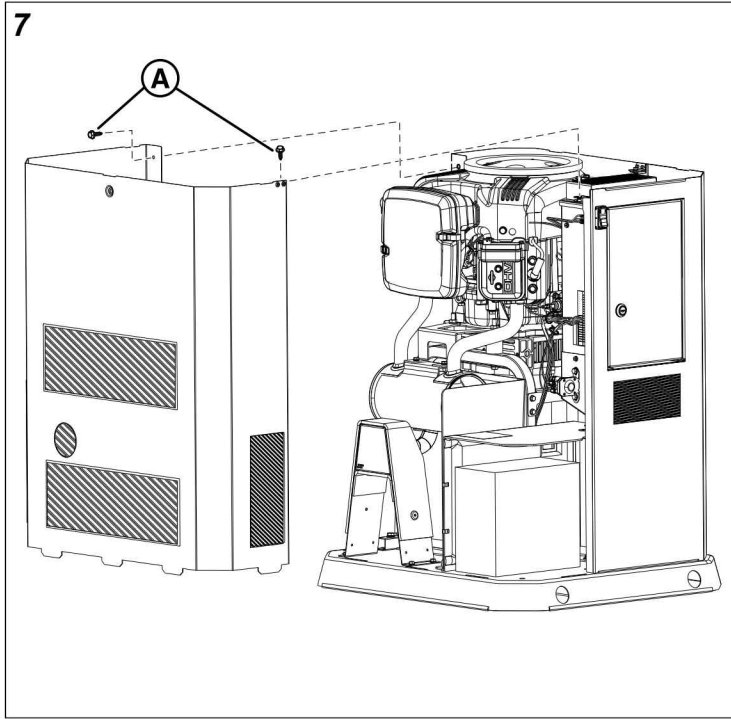

2. If installed for wind rating, remove the fasteners (A, Figure 8). The support brackets (B) do not need to be removed.

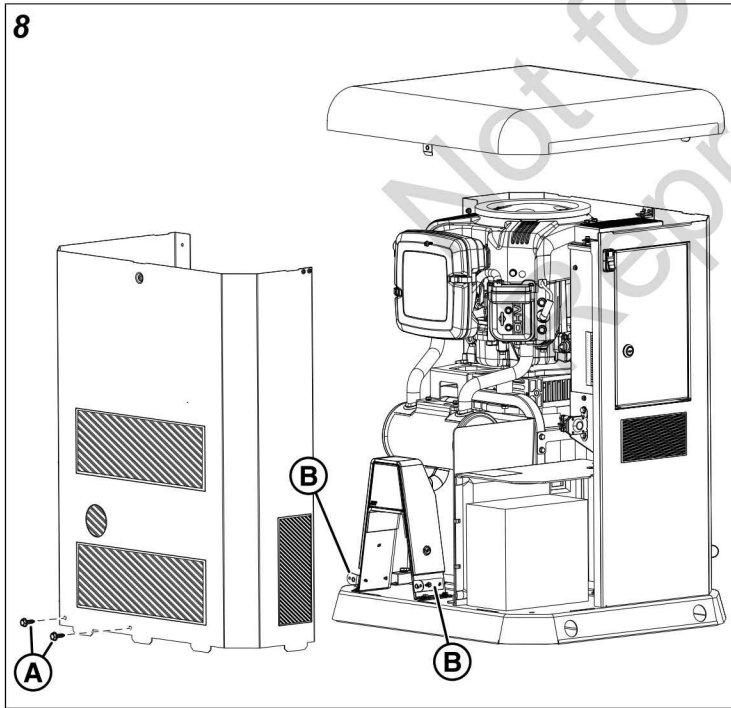

3. Lift and flex panel outward and off of the base. Use caution to prevent damage to the battery box.

## Field-Connections Access Panels – Installation and Removal (Figure 9)

1. Install or remove the field-connections access panels (A and B) by removing the fasteners (C) that attach the panels to the enclosure.

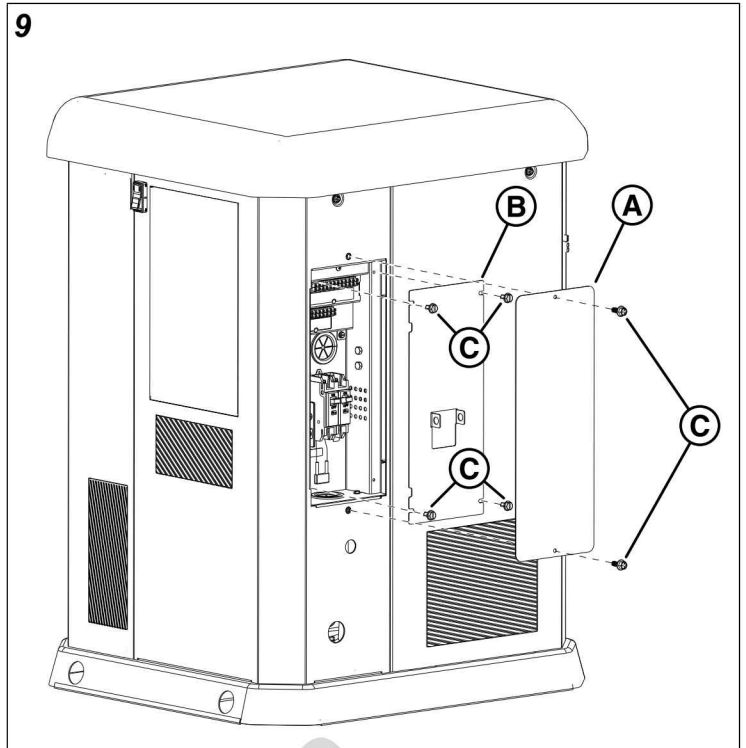

## Access Door for the Controller, Fuse and LED Light – Open and Close (Figure 10)

1. This door (A) gives access the generator's controller (C), battery charger LED view window (D) and fuse (E). If it is locked (B) use the keys supplied with your generator.

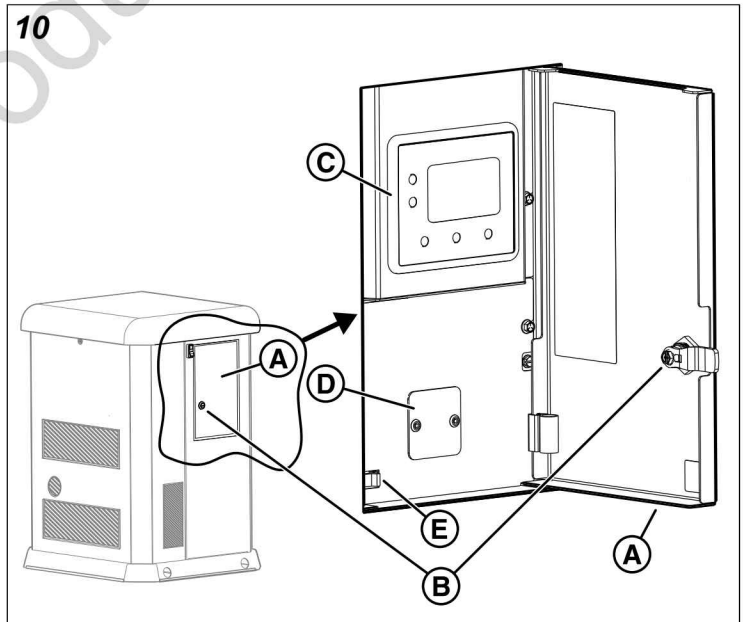

## Fuel Installation Plan



### WARNING

Propane and Natural Gas are extremely flammable and explosive, which could cause burns, fire or explosion resulting in death or serious injury.

- Installation must be performed by a licensed professional.
- Install the fuel supply system according to NFPA 37 and other applicable fuel-gas codes.
- Before placing the generator into service, the fuel system lines must be properly purged and leak tested.
- NO leakage is permitted.
- DO NOT operate engine if smell of fuel is present.



### WARNING

Propane and Natural Gas are extremely flammable and explosive, which could cause burns, fire or explosion resulting in death or serious injury.

- DO NOT operate the equipment if the fuel shut-off valve is missing or inoperative.



### WARNING

Propane and Natural Gas are extremely flammable and explosive, which could cause burns, fire or explosion resulting in death or serious injury.

- LP gas is heavier than air and will settle in low areas.
- Natural gas is lighter than air and will collect in high areas.
- The slightest spark could ignite these fuels and cause an explosion.
- DO NOT allow any open flame, spark, heat, or lit cigarette.

**NOTICE:** DO NOT install the supplied flexible fuel line underground or in contact with the ground. Keep the entire flexible fuel line visible for periodic inspection. Do not conceal it or run it within any wall, floor, or partition. Never let the line contact these structures.

**NOTICE:** DO NOT bend the supplied flexible fuel line.

The following information addresses the planning phase of installations for technicians specializing in gaseous fuel systems. Always obey the local applicable fuel-gas codes affecting the installation site. Consult your local fuel supplier or fire marshal with any questions or problems.

**TO THE INSTALLER:** Consult with the generator owner(s) and address any technical considerations affecting their installation plans before applying these guidelines.

The general rules that follow apply to piping on gaseous fuel systems:

- The piping material must follow federal and local codes, with rigid mounting and protection against vibration.

- Protect piping from physical damage, especially where it passes through flower and shrub beds and other cultivated areas where damage can occur.
- Install the provided flexible fuel line (B, Figure 11) between the generator fuel inlet port (A) and the rigid piping to prevent excessive stress on the piping material due to thermal expansion and contraction.
- Provide a union (C) or flanged connection downstream to allow for future removal.
- Install a manometer test port (D) for vapor fuels. Use the port to install a manometer and check if the engine receives the proper fuel pressure adequate for operation. See the service center for a digital or analog manometer designed for vapor fuels only (part number 19495). After completing the initial test runs, remove the manometer and plug the port.
- For vapor fuels only: Protect piping from freezing in areas that are prone to the formation of hydrates or ice. When terminating hard piping, use a sediment trap (E) where condensate liquid cannot likely freeze.
- Install a minimum of one accessible, approved manual shut-off valve (F) in the fuel supply line within 6 ft (1.8 m) of the generator.
- Install a manual shut-off valve in the interior of the building.
- Increase strength and flexibility of the piping supports and connections in areas prone to earthquakes, tornados, flood hazards, and unstable ground.
- Make sure that the size of the piping is adequate enough to maintain the required supply pressures and volume flow under varying generator load conditions, with all gas appliances connected to the fuel system turned on and operating.
- Use a pipe sealant or joint compound approved for use with natural gas/liquefied petroleum on all threaded fittings to reduce the possibility of leakage.

**NOTICE:** Keep thread sealant out of the gas piping to prevent damage to component parts.

- Purge and leak-test piping according to applicable codes and standards.

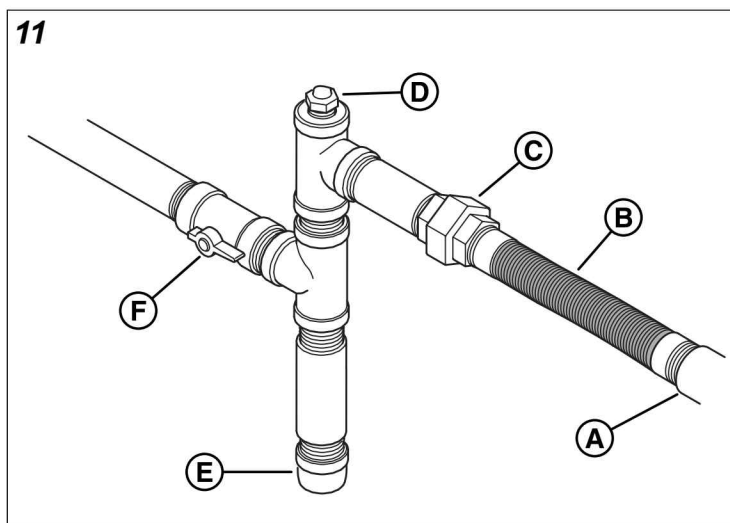

- (A) Generator Fuel Inlet

- (B) Flexible Fuel Line
- (C) Union Fitting
- (D) Manometer Test Port
- (E) Sediment Trap
- (F) Manual Shut-off Valve

- In engines set up to run on propane (liquefied petroleum), You must use commercial-grade HD-5 propane.

Natural gas or LP engines are certified to operate on natural or liquid propane gas. The emissions control system for this engine is EM (Engine Modifications).

## Fuel Consumption

Estimated fuel supply requirements at half and full load for natural gas and LP vapor fuels are shown in the table that follows:

### LP Vapor (Propane)

	13kW	
1/2 Load	BTU/hr (MJ/hr)	154,000 (170)
	ft3/hr (m3/hr)	62 (1.8)
	gal/hr (L/hr)	1.7 (6.4)
Full Load	BTU/hr (MJ/hr)	258,000 (280)
	ft3/hr (m3/hr)	103 (3.0)
	gal/hr (L/hr)	2.9 (10.7)

### Natural Gas

	13kW	
1/2 Load	BTU/hr (MJ/hr)	119,000 (130)
	ft3/hr (m3/hr)	119 (3.4)
Full Load	BTU/hr (MJ/hr)	212,000 (230)
	ft3/hr (m3/hr)	212 (6.0)

Physical Properties	LP Vapor	Natural Gas
Normal Atmospheric State	Gas	Gas
Boiling Point °F (°C)	-44 (-42)	-259 (-167)
Heating Value		
BTU/gal (MJ/L) liquid (Net LHV*)	83,340 (23.23)	63,310 (17.65)
BTU/gal (MJ/L) liquid (gross**)	91,547 (25.52)	n/a
BTU/ft3 (MJ/m3) gas	2,500 (93.15)	1,000 (37.26)
Density – ft3/gal (m3/L)	36.39 (0.27)	57.75 (0.43)
Weight – lb/gal (kg/L)	4.24 (0.51)	2.65 (0.32)

\* LHV (Low Heat Value) is the more realistic rating.

\*\* Gross heat value does not consider heat lost in the form of water during combustion.

## Fuel Type

Consider the type of fuel that your generator uses, as it affects the entire installation process. The system was factory tested and adjusted using natural gas, but it can be converted to use liquefied petroleum vapor. For correct engine function, consider factors that affect each of these fuels, such as the location and the duration of possible utility interruptions. When choosing fuel type, obey these guidelines that follow:

- Use a clean, dry fuel that is free of moisture or any particulate material. Using fuels outside the recommended values can cause performance problems.

## Fuel Pressure

Both liquefied petroleum (LP) and natural gas (NG) fuel supply pressure at the generator's fuel inlet port must be a minimum value at full load with all gas appliances turned on and in operation.

Natural Gas must be 3.5 to 7 in (89 to 178 mm) Water Column (WC).

Liquefied Petroleum must be 11 to 14 in (279 to 356 mm) WC.

Make sure that all gas line shut-off valves are OPEN and that adequate fuel pressure is available whenever automatic operation is needed.

## Power Loss

Engine power will decrease 3.5% for each 1,000 feet (300 meters) above sea level and 1% for each 10°F (5.6 °C) above 77 °F (25 °C).

## Fuel Conversion

The engine of your home generator system is factory calibrated and set to operate on natural gas (NG). It may also be operated on liquefied petroleum (LP) vapor.

**NOTICE:** Units are set to NG at the factory. Both screw settings are given in the list that follows.

The initial factory NG fuel settings are:

- Idle Screw (C, Figure 14): 3/8 of a turn
- Main Screw (D): 1-3/8 turns

The LP fuel settings are:

- Idle Screw (C): 3/4 of a turn
- Main Screw (D): 1/8 of a turn

To convert to either fuel, do the steps that follow:

1. Push the ON/OFF Switch (A, Figure 12) to the "OFF" (0) position (see switch location in the *Features and Controls* section).
2. Remove utility power to the generator to de-energize the battery charger.
3. Remove the roof (see the *Access Panels: Installation and Removal* section).
4. Remove the 15 Amp fuse (B) from the fuse holder (see fuse location in the *Features and Controls* section).
5. Remove the front panel (see the *Access Panels: Installation and Removal* section).
6. Disconnect the negative (-) cable at the battery.

7. Push the fuel-selector toggle switch (B, Figure 13) that is located on the top of the field connection box to the correct position — LP or NG (A).
8. Using a slotted screwdriver turn screws (C and D, Figure 14) clockwise until they are snug.

**NOTICE** Do NOT over-tighten. It can cause damage to the mixer port.

9. Using a slotted screw driver turn screw (C) counterclockwise the number of turns specified in the **NOTICE** at the start of this section.
10. Using a slotted screw driver turn screw (D) counterclockwise the number of turns specified in the **NOTICE** at the start of this section.
11. Connect the negative (-) cable at the battery.
12. Install the front panel (see the *Access Panels: Installation and Removal* section).
13. Install the 15 Amp fuse (B, Figure 12) into the fuse holder (see fuse location in the *Features and Controls* section).
14. Install the roof (see the *Access Panels: Installation and Removal* section).
15. Push the ON/OFF Switch (A) to the “ON” (I) position (see switch location in the *Features and Controls* section).
16. Unlock (if necessary) and open the controller access door and verify that the controller is in **Manual Mode**.
17. Push and hold the CONFIG button to access the configuration menu.
18. Push SELECT to edit the items in the configuration menu.

**NOTICE** If you are changing the setup in the generator's controller from the factory setting of NG fuel to LP fuel you will need to enter the Configuration Menu by using the Dealer Password, which is available on the Power Portal.

19. Navigate to “SELECT PROFILE” and push select on the correct profile for the generator. For example “13KW\_LP” for operating a 13kW unit running on LP fuel

**NOTICE** Selecting a profile that is not intended for the generator can cause the generator to run erratically and can result in damage

20. To save the new fuel setting, push and hold the STOP/ CONFIG button until “Saving Settings...” is displayed.
21. DO NOT change the fuel regulator setting. Whether you are using NG or LP fuel this setting MUST be left at the factory setting of NG (E, Figure 15 ).

22. For Additional information on the operation of the generator controller please refer to the online “*Operation Instructions GC1030 Series GENSET Controller*” manual associated with your generator.

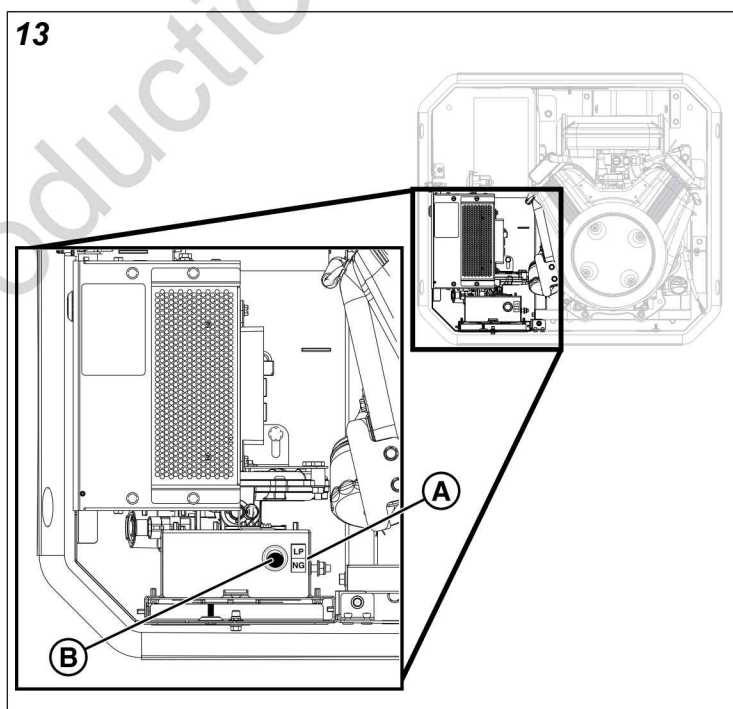
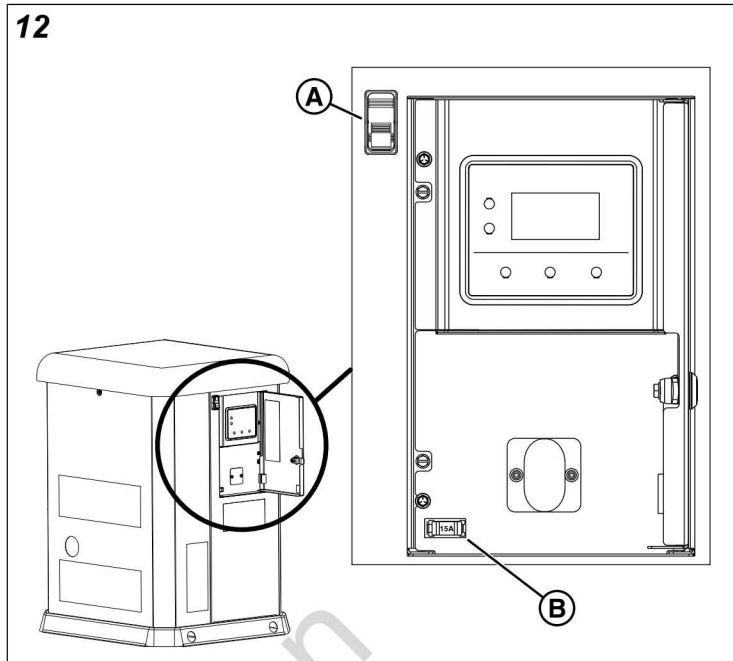



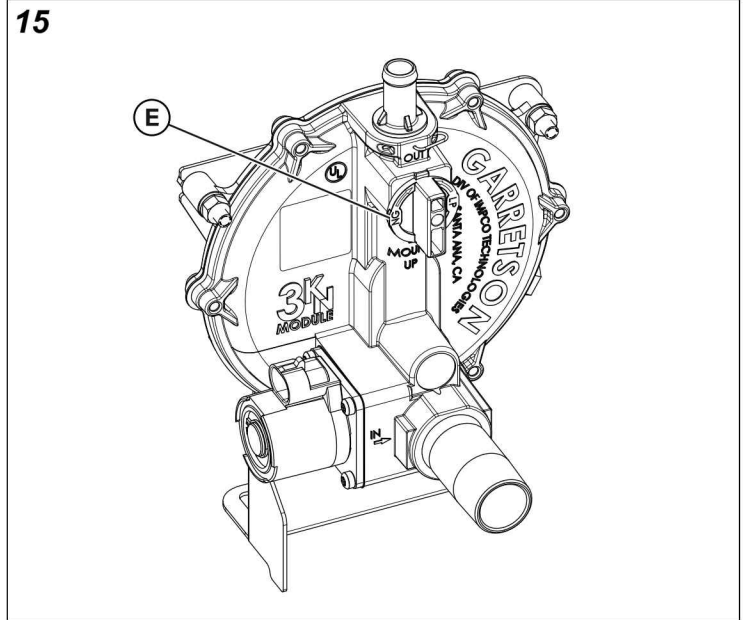
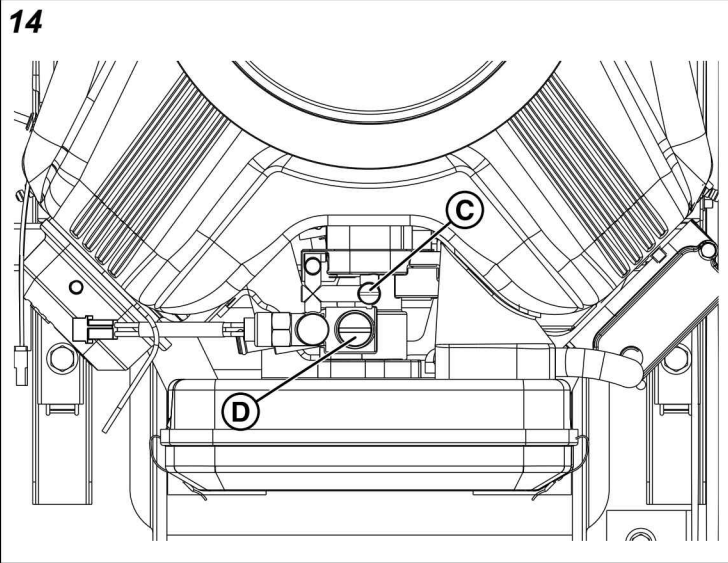

## Electrical Field Connections



### WARNING

Generator and utility voltage could cause electrical shock or burn resulting in death or serious injury.

- Installation must be performed by a licensed professional.
- Disconnect all sources of electricity before installing or servicing equipment.
- Ground system before applying power.



### WARNING

Hazardous Voltage - Installing low and high voltage wire in same conduit could cause electric shock or burns, resulting in death or serious injury.

- Do not run low and high voltage wire in the same conduit unless the insulation rating on ALL wiring is rated for 600 V. See NFPA 70 for more information.

1. Remove the field-connections access panels (see *Access Panels: Installation and Removal* section)
2. Insert the field wires through the knock-out hole.

**NOTICE** If necessary, enlarge the knock-out hole to a size that will allow the wires to fit through.

**NOTICE** Use a vacuum to remove dirt or metal shavings in and around the generator. Do not use a blower or compressed air because debris can get caught in electrical and mechanical components. This can cause damage or malfunction.

3. Remove the fasteners (A, Figure 16) from the bottom plate of the field-connection box.
4. Pull the wires up through the rubber grommet (B) and up into the field-connection box.
5. Install the bottom plate to the tabs in the field-connection box with the fasteners (A).
6. Make the field connections as shown in the image (Figure 17) and table that follow.
7. Install the field-connections access panels (see *Access Panels: Installation and Removal* section).

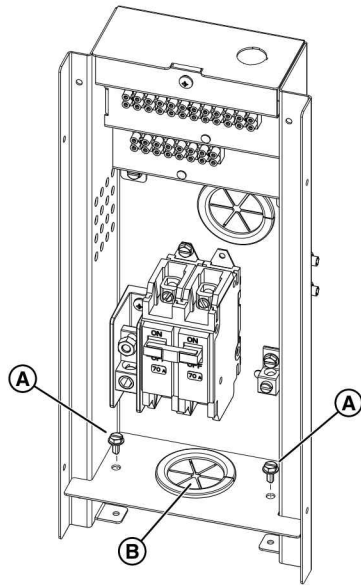

Not for  
Reproduction

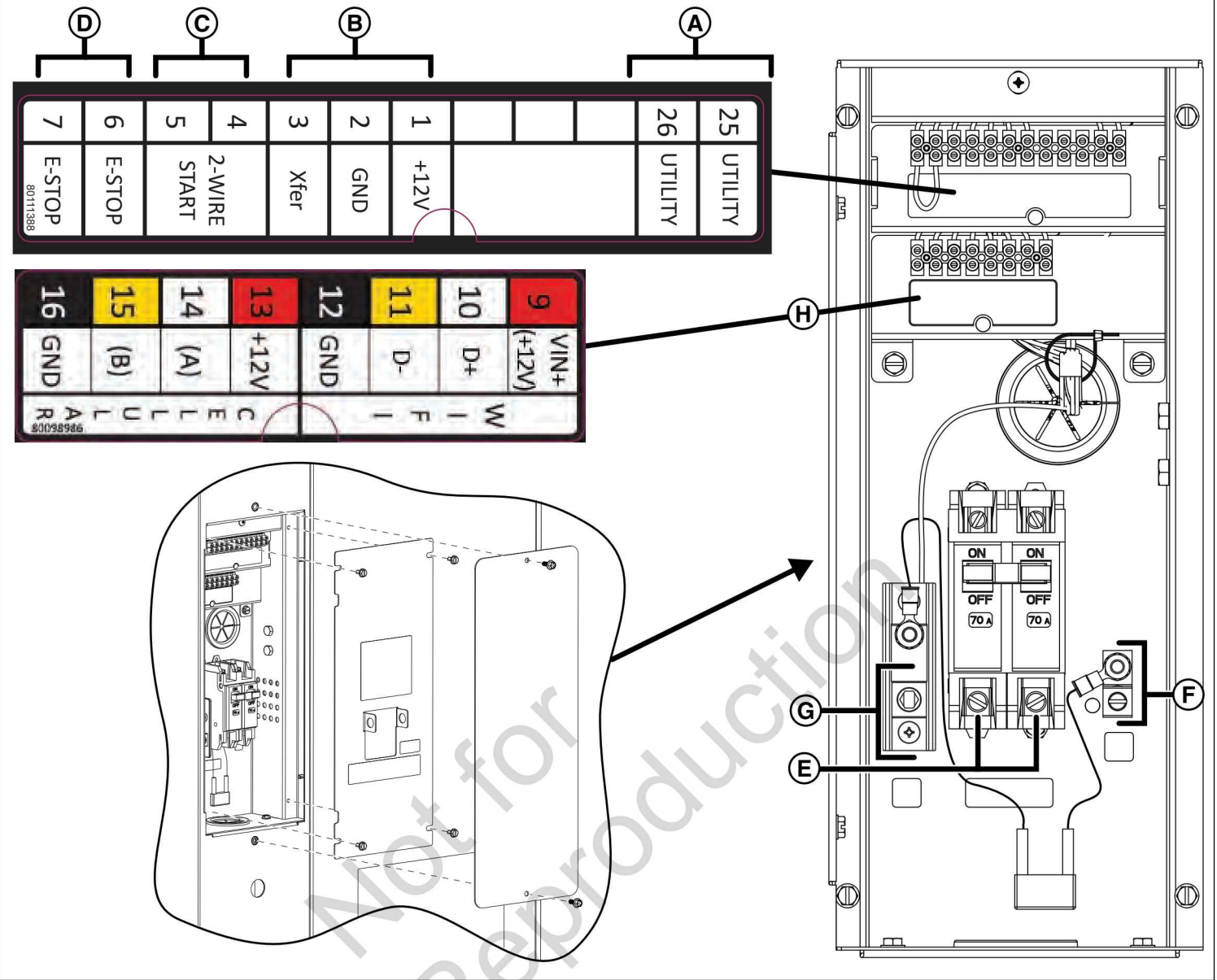

Legend (Figure 17):

- (A) Utility and Field Connections Terminal Block — Connects utility 240 VAC from the fuse block in ATS to the controller. Connect only one wire per terminal. Reference the table that follows for field connections.
- (B) Transfer Switch Connection — Controls the transfer switch contactor.
- (C) Two-wire Start — Helps provide optional remote start contact.
- (D) E-Stop — Use with the optional external E-Stop
- (E) Power Connection (L1 and L2) — Connects to the transfer switch
- (F) Ground Connection — Connects to the transfer switch ground wire
- (G) Neutral Connection — Connects to the transfer switch neutral wire
- (H) Communications Terminal Block — Reference the table that follows:

Pin Number	Description	Wire Type	Connect To	Notes
1	+12V	18AWG[1mm <sup>2</sup> ] conductors, 600V minimum, 90°C Cu wire	Transfer switch basic controller J7-8 12VDC	Transfer switch Transfer Signal (only works with basic Transfer Switch Controller)
2	GND	18AWG[1mm <sup>2</sup> ] conductors, 600V minimum, 90°C Cu wire	Transfer switch basic controller J7-7 GND	
3	Xfer	18AWG[1mm <sup>2</sup> ] conductors, 600V minimum, 90°C Cu wire	Transfer switch basic controller J7-4 T/R	

Pin Number	Description	Wire Type	Connect To	Notes
4	2-WIRE START	18AWG[1mm <sup>2</sup> ] conductors, 600V minimum, 90°C Cu wire	Refer to Transfer switch manual to verify if this function is available	Contact Close for Genset Start. <b>(Only for transfer switch that provides this option)</b> . Mains monitoring must be disabled in the controller
5	2-WIRE START	18AWG[1mm <sup>2</sup> ] conductors, 600V minimum, 90°C Cu wire		
6	E-STOP	18AWG[1mm <sup>2</sup> ] conductors, 600V minimum, 90°C Cu wire	E-Stop Switch	Contact Open to Shutdown Genset
7	E-STOP	18AWG[1mm <sup>2</sup> ] conductors, 600V minimum, 90°C Cu wire	E-Stop Switch	
8	Not Used	-	-	-
9	VIN+ (+12V)	18AWG[1mm <sup>2</sup> ] conductors, 600V minimum, 90°C Cu wire	Refer to the Amplify Gateway Manual	Comm to WIFI module Twisted pair #1: +12V and GND Twisted pair #2: (D-) and (D+)
10	D-	18AWG[1mm <sup>2</sup> ] conductors, 600V minimum, 90°C Cu wire		
11	D+	18AWG[1mm <sup>2</sup> ] conductors, 600V minimum, 90°C Cu wire		
12	GND	18AWG[1mm <sup>2</sup> ] conductors, 600V minimum, 90°C Cu wire		
13	+12V	18AWG[1mm <sup>2</sup> ] conductors, 600V minimum, 90°C Cu wire	Not used	Not used
14	(B)	18AWG[1mm <sup>2</sup> ] conductors, 600V minimum, 90°C Cu wire		
15	(A)	18AWG[1mm <sup>2</sup> ] conductors, 600V minimum, 90°C Cu wire		
16	GND	18AWG[1mm <sup>2</sup> ] conductors, 600V minimum, 90°C Cu wire		
25	25	14AWG [2.5mm <sup>2</sup> ] 600V minimum, 90°C Cu Wire	Transfer switch Utility	Delivers power to the generator's battery charger, controller, optional battery warmer, optional oil warmer, and optional fuel regulator warmer. Also, when voltage on these leads is lost in AUTO Mode, generator will start if Mains Monitoring is enabled (default setting)
26	26	14AWG [2.5mm <sup>2</sup> ] 600V minimum, 90°C Cu Wire	Transfer switch Utility	

- For power output connection (L1, L2, Neutral (N), and Ground), refer to the National Electric Code (NEC) and local codes for correct wire specifications.
- For communication wires use 600V wire and #18 AWG [1mm<sup>2</sup>] twisted-pair conductors that do not exceed a length of 500 ft (150 m).
- When connecting to the terminal block, fasten only one wire to each connector screw.
- Torque terminal block screws to 4.4 in-lb [0.5 Newton meter (N·m)].

### Connection Specifications

Connection	Temperature Rating: °F (°C)	Recommended Wire Size (AWG)	Torque Specifications
Circuit Breaker (copper or aluminum)	140 °F / 167 °F (60 °C / 75 °C)	6 to 1/0	45 in-lbs (5.08 Nm)
Neutral Lug (copper or aluminum)	167 °F (75 °C)	2/0 to 14 CU 2/0 to 12 AL	120 in-lbs (13.56 Nm)
Ground Lug (copper or aluminum)	194 °F (90 °C)	14 to 2	50 in-lbs (5.65 Nm)

### AC System Connections

The generator uses a single-phase, three-wire AC connection system (Figure 18). The stator assembly consists of a pair of stationary windings with two leads appearing from each winding. The junction of leads 22 and 33 forms the neutral lead.

**NOTICE:** Neutral is not bonded to ground at generator.

**NOTICE:** The generator must be used with an UL listed transfer switch that is compatible with the generator. Only use the generator with a listed transfer switch that is compatible with the generator.

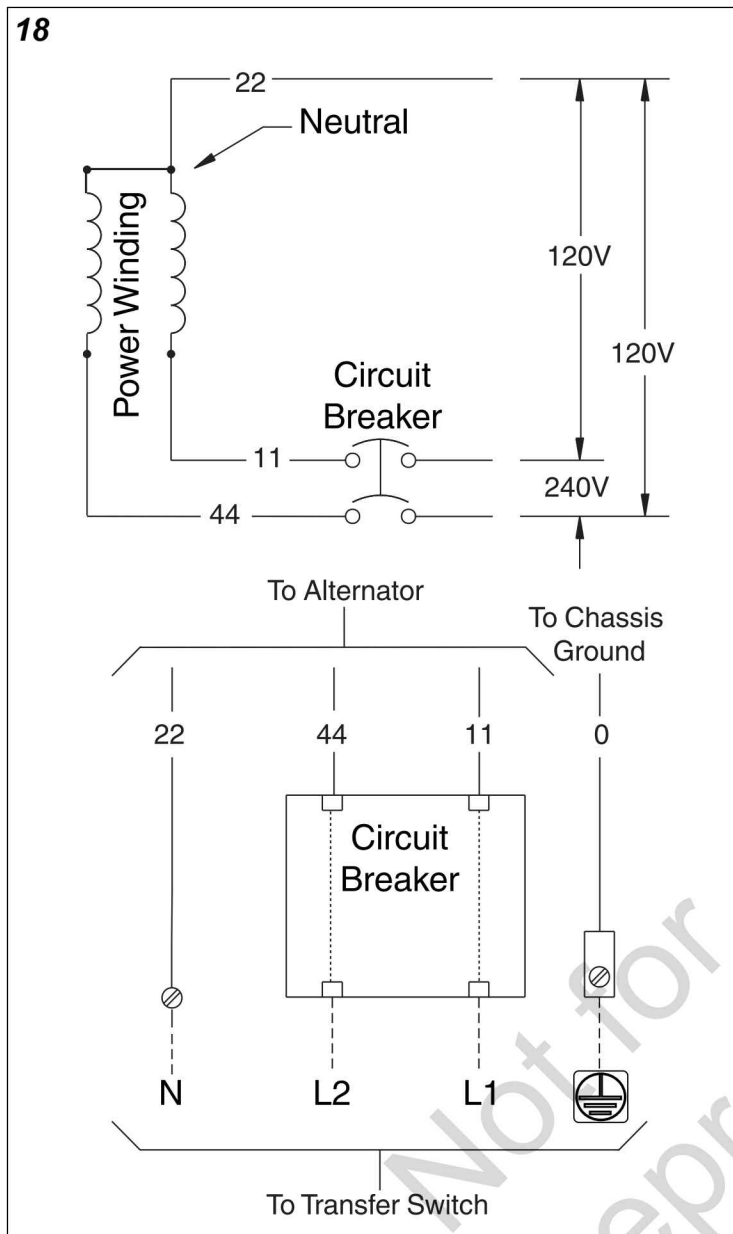

## Ground the Generator

Unless mandated by local code, additional chassis grounding to earth at the generator is not required. Any grounding at the generator must use paint-piercing lock washers (or their equivalent). Any listed terminals must be installed per the terminal supplier's instructions. All grounding and terminal installations must comply with national electrical codes and local requirements.

## Engine Oil

**NOTICE:** Any attempt to crank or start the engine before it has been correctly filled with the recommended oil will result in equipment failure and service codes.

- Refer to *Maintenance* in the *Operation* section of this manual for oil fill information.
- Damage to equipment resulting from failure to obey this instruction will void the engine and generator warranty.

This engine ships from the factory pre-run and filled with full synthetic oil (API SJ/CF 5W-30). This allows for system operation in a wide range of temperature and climate conditions. Before starting the engine, check the oil level as described in the *Maintenance* section of this manual.

The use of full synthetic oil does not alter the required oil change intervals described in the *Operation* section of this manual.

## Battery

**WARNING** 

Storage batteries give off explosive hydrogen gas during recharging. Slightest spark could ignite hydrogen and cause explosion, resulting in death or serious injury.

- DO NOT dispose of battery in a fire. Recycle battery.
- DO NOT allow any open flame, spark, heat, or lit cigarette during and for several minutes after charging a battery.
- Discharge static electricity from body before touching batteries by first touching a grounded metal surface.

**WARNING**  

Battery electrolyte fluid contains acid and is extremely caustic. Contact with battery contents could cause severe chemical burns.

- DO NOT open or mutilate the battery.
- Wear protective goggles, rubber apron, rubber boots and rubber gloves.
- Immediately wash electrolyte from skin with water.
- If electrolyte contacts eyes, immediately flush with water and seek medical attention.
- Spilled electrolyte is to be washed down with an acid neutralizing agent.
- A common practice is to use a solution of one pound (500 grams) bicarbonate of soda to one gallon (4 liters) of water. The bicarbonate of soda solution is to be added until the evidence of reaction (foaming) has ceased. The resulting liquid is to be flushed with water and the area dried.

The installer must supply and install a rechargeable 12 V starting battery. The starting battery **MUST** conform to the specifications shown in the chart that follows.

## Battery Specifications

Specifications	Standard	Cold Start (Less than 30 °F / -1 °C)
Volts	12 VDC	12 VDC
Amps (Minimum)	540 CCA (Cold Cranking Amps)	800 CCA (Cold Cranking Amps)
Construction	Wet Lead Acid	Wet Lead Acid
Terminal Type	Top Post Type Battery	Top Post Type Battery
Dimensions (Maximum)	BCI Size 26 or BCI Size 51	BCI Size 24

**WARNING** 

With the battery connected, the generator could crank and start without warning resulting in death or serious injury.

- Do not connect the negative (-) cable at the battery until the installation is complete.

Install the battery as described in *Servicing the Battery* in the *Maintenance* section of this manual. Make sure that the NEGATIVE cable is connected last and that the red POSITIVE terminal insulator is secure.

## System Controller

The generator's controller, located inside the generator housing, is shown in the image that follows (Figure 19). Brief descriptions of the controls used during installation are:

- (A) Menu/Programming Navigation Buttons
- (B) Stop/Config Button
- (C) Start/Select Button
- (D) Auto/Manual Button
- (E) Alarm
- (F) Digital Display — Displays generator mode, menu options, and alarms

**NOTICE:** Detailed descriptions of the controls are located in the *Description of Control Keys* section inside the online "Operation Instructions GC1030 Series GENSET Controller" manual associated with your generator.

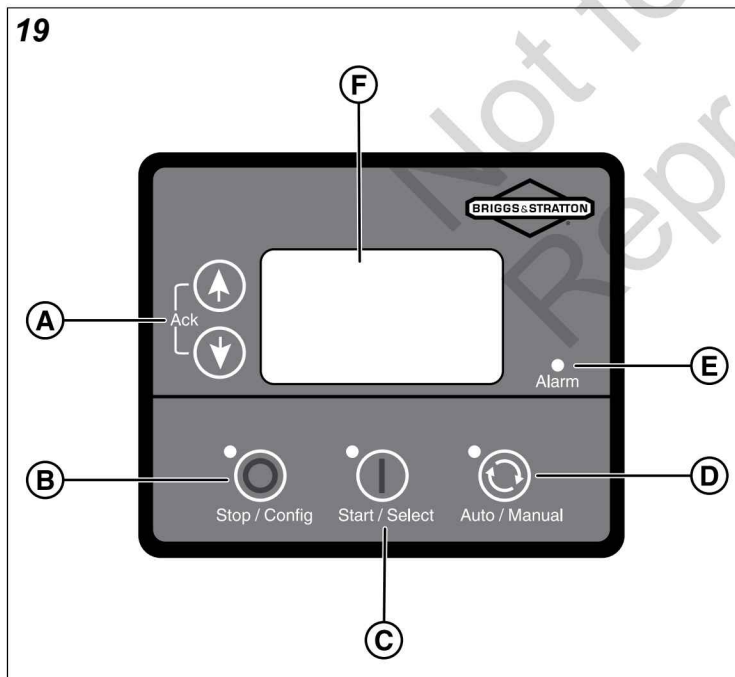

## Initial Start-Up (No Load)



### WARNING

Exhaust heat/gases could ignite combustibles causing a fire, resulting in death or serious injury.

- Remove all combustible materials from in and around the generator compartment.

The unit has been set-up for NG operation at the factory. Fuel conversion, if needed, must be completed prior to performing these steps. See Fuel Conversion.

Before operating the standby generator or placing it into service, inspect the entire installation carefully. Then, begin testing the system without electrical loads connected, as shown in the steps that follow:

1. Remove the screws (A, Figure 20) that secure the field-connections access panels to expose unit's circuit breaker.
  2. Connect an accurate multi-meter to line side of the generator's main circuit breaker.
  3. Set the generator's main circuit breaker to the ON (closed) position.
  4. Install the 15 Amp fuse (see fuse location in the *Features and Controls* section).
  5. Push the ON/OFF switch to the ON (I) position (see switch location in the *Features and Controls* section).
  6. Push the START/SELECT button on the control board. The engine will start in Low Idle Mode (LIM). Push again to bring the engine to full speed.
- NOTICE:** When the generator is started for the very first time, it will require that any air in the gaseous fuel lines be purged. This can cause the engine to run roughly for a few minutes
7. Listen for unusual noises, vibration or other indications of abnormal operation. Look for oil leaks while the engine runs.
  8. Let the engine warm up for approximately 5 minutes to allow internal temperatures to stabilize.
  9. Check the generator output at load side of circuit breaker. The voltage must be 225 - 250 Volts and the frequency must be 59 - 61 Hz.
  10. Check the generator output between one generator connection lug and the neutral lug, then between the other generator connection lug and the neutral lug. In both cases, voltage reading must be between 112 and 125 Volts.
  11. Push the STOP/CONFIG button on the control board. The engine will enter cool-down mode for approximately 5 minutes. To bypass cool-down mode, push the the STOP/CONFIG button again to stop the engine.
  12. Install the circuit breaker cover.

13. When the test is completed and successful, install the front panel and the roof if they were removed.

20

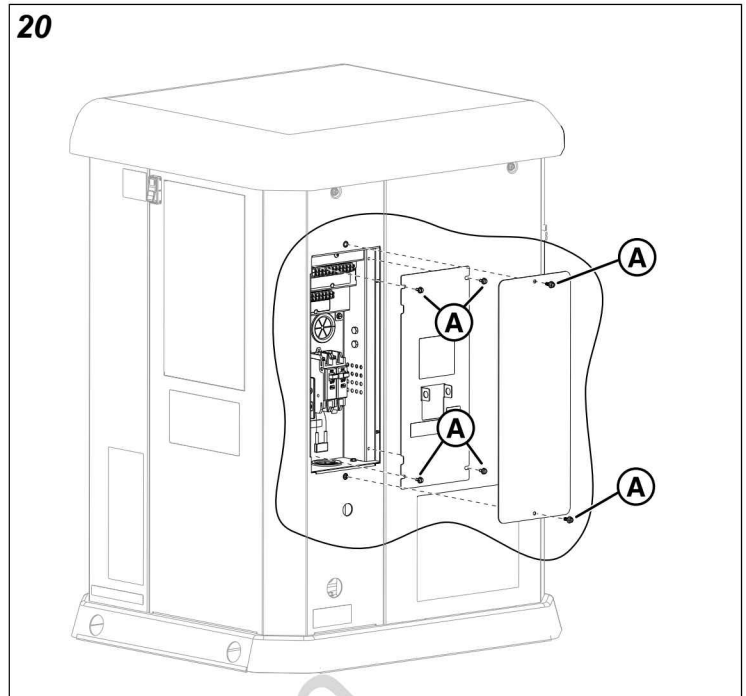

# Operation

## WARNING

Failure to read and obey the operator's manual, all warnings, and operating instructions could result in death or serious injury.

## Features and Controls

### 13kW Generator (Figure 21)

21

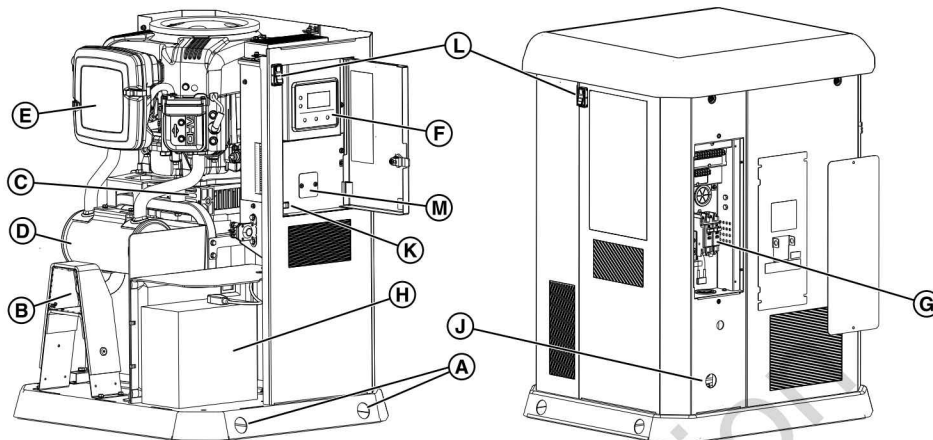

Generator is shown with the roof and access covers removed for clarity.

Legend:

- (A) Lifting Holes — Provided at each corner for lifting generator.
- (B) Exhaust Port — High-performance muffler lowers the engine noise to comply with most residential codes.
- (C) Alternator — An electrical machine that generates an alternating current.
- (D) Muffler — A device that reduces engine noise.
- (E) Air Cleaner — Uses a dry type filter element to protect the engine by filtering dust and debris out of intake air.
- (F) Controller — Used for various test, operation and maintenance functions.
- (G) Circuit Breaker — Protects the system from short circuits and over-current conditions.
- (H) Battery Compartment — For the installer supplied 12 Volt DC battery that provides power to start the engine.
- (J) Fuel Inlet Port — Attach appropriate fuel supply to generator here.
- (K) Fuse — Protects the DC electrical system from short circuits and over-current conditions.
- (L) ON / OFF Switch — Used to turn the generator on (I) and off (O).
- (M)\* Battery Charger LED View Window — Monitors output voltage. See the table that follows for information on labels and colors.

#### \* Battery Charger LED Lights and Meanings

LABEL	COLOR	DEFINITION
MANUAL BOOST	Red	Manual Boost Mode - Output voltage is 14.4V
AUTO BOOST	Green	Bulk Charge - Output voltage at 13.7V, utility charging battery
FLOAT	Blue	Battery Charged - trickle at under 13.2V
REV BATT	Red	Reverse battery mode - Battery charger connections reversed

#### NOTES:

1. Continuous switching between Blue & Green = Charger Output Short Circuit
2. No LEDs = Utility Power Loss



## Important Owner's Considerations



### WARNING

Engine exhaust contains carbon monoxide, a poisonous gas that could kill you in minutes. You cannot smell it, see it, or taste it. Even if you do not smell exhaust fumes, you could still be exposed to carbon monoxide gas.

- Carbon monoxide detector(s) **MUST** be installed and maintained indoors according to the manufacturer's instructions/recommendations. Smoke alarms cannot detect carbon monoxide gas.
- If you start to feel sick, dizzy, weak, or your carbon monoxide alarm sounds while using this product, get to fresh air right away. Call emergency services. You may have carbon monoxide poisoning.

### Engine Oil

The engine ships from the factory pre-run and filled with full synthetic oil (API SJ/CF 5W-30). This allows for system operation in a wide range of temperature and climate conditions. Before starting the engine, check the oil level as described in the *Maintenance* section.

**NOTICE:** Any attempt to crank or start the engine without it being correctly filled with the recommended oil will result in equipment failure.

- Damage to equipment resulting from failure to obey this instruction will void engine and generator warranty.

### Battery

The installer must supply a rechargeable 12 VDC starting battery. See *Battery* in the *Installation* section in this manual.

### 15 amp Fuse

Make sure that the fuse is correctly installed before operating your generator.

## Automatic Operation Sequence

The generator's controller monitors utility voltage. If the utility voltage drops below a preset level, the controller signals the engine to crank and start. When the utility voltage restores above a preset voltage level, the engine receives signals to shut down. The actual system operation is not adjustable and undergoes sequencing by sensors and timers on the controller in the following manner:

### Utility Voltage Dropout Sensor

- This sensor monitors the utility source voltage.
- If the utility source voltage drops below approximately 88% of the nominal supply voltage, the sensor initiates a timer.
- The engine cranks and starts once the timer has expired.

### Utility Voltage Pickup Sensor

This sensor monitors the utility voltage. When the utility voltage restores above approximately 90% of the nominal

source voltage, a shut-down timer initiates and the engine cools down.

### Engine Cool-down Timer

When the system senses the utility power, the load transfers to the utility source and the engine enters a five-minute cool-down period.

## Set the Exercise Timer

1. Push and hold the STOP/CONFIG button (B, Figure 22).
2. Push the START/SELECT button (C) to enter WRITE MODE.
3. Enter the password (0000) by using the arrow keys (A) and the START/SELECT button (C).
4. In the CONFIGURATION screen use the arrow keys (A) to find "MODULE."
5. Push the START/SELECT button (C) and using the arrow keys (A) find "AUTO EXERCISE."
6. Push the START/SELECT button (C) and using the arrow keys (A) select each parameter and choose the desired settings.
7. To save your settings when completed, push and hold the STOP/CONFIG button (B) until "Saving Settings" shows on the display.

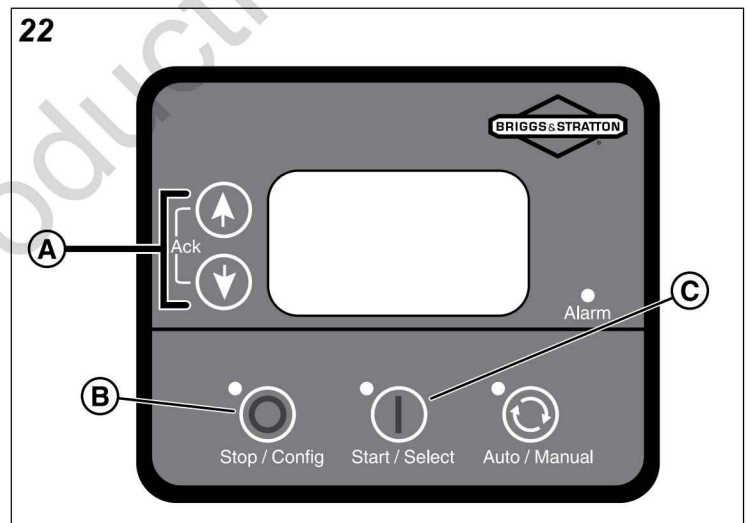

A detailed list of all the on screen parameters is located in the *Configuration of GCU* section inside the online "*Operation Instructions GC1030 Series GENSET Controller*" manual associated with your generator.

# Maintenance

## Servicing the System – Before and After



### WARNING

Generator and utility voltage could cause electrical shock or burn resulting in death or serious injury.

- DO NOT allow unqualified persons to operate or service this equipment.



### WARNING

With the battery connected, the generator could crank and start without warning resulting in death or serious injury.

- Before servicing, stop the generator and disconnect the negative (-) cable at the battery.

**BEFORE** doing maintenance on your generator, you **MUST** do the steps that follow:

1. Push the ON/OFF switch to the OFF (0) position (see switch location in the *Features and Controls* section).
2. Remove utility power to the generator to de-energize the battery charger.
3. Unlock and open or remove the roof as described in the *Access Panels: Installation and Removal* section.
4. Remove all of the access panels necessary to do the maintenance on your generator as described in the *Access Panels: Installation and Removal* section
5. Disconnect the negative (-) cable at the battery
6. Remove the 15 amp fuse from the fuse holder (see fuse location in the *Features and Controls* section)
7. Complete the service steps as specified.

**AFTER** doing maintenance on your generator, you **MUST** do the steps that follow:

8. Connect the negative (-) cable at the battery.
9. Install all of the access panels that were removed on your generator as described in the *Access Panels: Installation and Removal* section
10. Install the 15 amp fuse into the fuse holder (see fuse location in the *Features and Controls* section).
11. Roof and controller: If the generator's controller is located on one of the side panels of the enclosure – install the roof if it was removed (see the *Access Panels: Installation and Removal* section). If the generator's controller is located under the roof – do not close or install the roof yet.
12. Restore utility power to the generator.
13. Push the ON/OFF switch to the ON (I) position (see switch location in the *Features and Controls* section)
14. Access the generator's controller and set the generator mode to AUTO

15. Close and lock the controller access door or close and lock the roof as described in the *Access Panels: Installation and Removal* section

**NOTICE** This depends on where the generator's controller is located. See the *Access Panels: Installation and Removal* section.

## Maintenance Schedule

Obey the hourly or calendar intervals of operation, whichever occurs first.

<b>Every 8 Hours of Operation or Daily</b>
Clean Debris
Check the Engine Oil Level
<b>Every 100 Hours of Operation or Annually</b>
Change the Air Filter
Change the Engine Oil and Filter
Replace the Spark Plugs
Check the Valve Clearance
Check the Circuit Breaker Torques
<b>Annually</b>
Clean the Oil Cooler Fins

Regular maintenance improves the performance and extends the life of the generator. See an authorized dealer for service.

## Generator Maintenance

The generator's warranty does not cover items that have been subjected to operator abuse or negligence. To receive full value from the warranty, the operator must maintain the generator as instructed in this manual.

The generator requires the owner to make some adjustments periodically to correctly maintain it.

Do all of the service and adjustments at least once each season. Obey the requirements in the *Maintenance Schedule* section.

Keep the unit clean. Operate the unit in an environment that is free of excessive dust, dirt, moisture, or any corrosive vapors. Do not allow the cooling air inlets and outlets on the enclosure to become clogged with snow, leaves, or other foreign material. To prevent generator damage caused by overheating, keep the enclosure cooling inlets and outlets clean and unobstructed at all times.

Examine the cleanliness of the unit frequently and clean it when dust, dirt, oil, moisture, or other foreign substances appear on its exterior and interior surface. Inspect the air inlet and outlet openings inside and outside the enclosure to make sure that no blockages are in the airflow.

**NOTICE:** Incorrect treatment of generator can damage it and shorten its life.

- DO NOT expose generator to excessive moisture, dust, dirt, or corrosive vapors.
- DO NOT insert any objects through cooling slots.

## Clean the Generator



### WARNING

Exhaust heat/gases could ignite combustibles causing a fire, resulting in death or serious injury.

- Keep the area near the generator clean and free of debris.

**NOTICE:** DO NOT use direct spray from a garden hose to clean the generator. Water can enter the engine and the generator and cause damage.

**NOTICE:** Periodically inspect the engine exterior for contamination and potential damage from dirt, leaves, rodents, spider webs, insects, etc. and remove.

1. **Before** you clean your generator, you **MUST** do steps 1–6 in the *Servicing the System* section and then continue to step 2 in this section.
2. Clean the generator using the steps that follow:
  - a. Wipe the exterior surfaces clean with a damp cloth.
  - b. Use a soft bristle brush and vacuum cleaner to loosen and pick up dirt and debris. Use low-pressure air (not to exceed 25 psi or 175 kPa) to blow away dirt and debris.
  - c. Clear any snow, leaves, or debris from the air inlets and outlets. Keep these openings unobstructed to prevent generator damage caused by overheating.
3. **After** you clean your generator, you **MUST** do steps 8–15 in the *Servicing the System* section.

## Engine Maintenance

### Engine Oil

Use only Briggs & Stratton® SAE 5W-30 full synthetic engine oil. Other full synthetic high-quality detergent oils are acceptable if classified for service SJ or higher.

### Check Engine Oil Level

**NOTICE** The dipstick or the markings on the dipstick (Figure 23) can look different than the one with your model of generator.

Maintain the oil level between the “ADD” and the “FULL” marks on the dipstick. Before you check the oil level, follow these steps to make sure that an accurate reading appears on the dipstick:

Oil must be maintained between the “ADD” and the “FULL” marks on the dipstick. To make sure that an accurate reading is shown on the dipstick, make sure the following steps are taken before you check the oil level.

1. **Before** you do engine maintenance on your generator, you **MUST** do steps 1–6 in the *Servicing the System* section and then continue to step 2 in this section.
2. If the generator was recently operating, wait five minutes for the oil to drain back into the oil pan.

3. Remove the dipstick. Wipe it with a clean cloth or paper towel. Then, push the dipstick all the way into the dipstick tube.
4. Remove the dipstick and note the amount of oil on it. The oil must reach a level between the “ADD” and “FULL” marks on the dipstick.
5. If the oil level is below the “ADD” mark (Figure 23), install the dipstick and proceed to the next step.

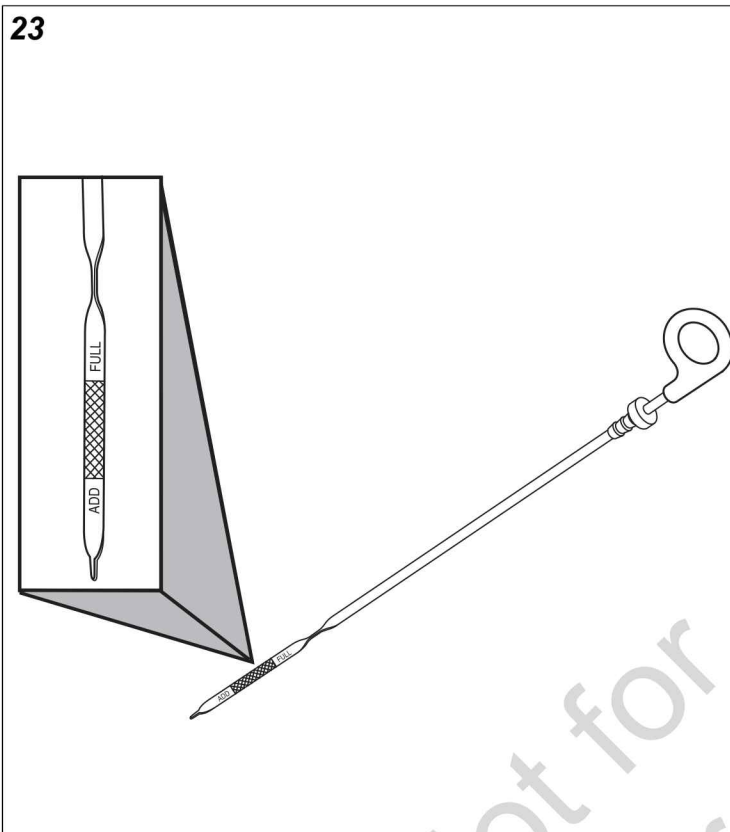

6. Remove the oil filler cap from the valve cover.
7. Add the required amount of oil to bring the level up to (but not over) the “FULL” mark on the dipstick. Install the oil fill cap on the valve cover and wipe up any spilled oil.
8. **After** you do engine maintenance on your generator, you **MUST** do steps 8–15 in the *Servicing the System* section.

## Change the Oil and the Oil Filter

**NOTICE:** Change the oil while the engine is still warm from operating

1. **Before** you change the oil and the oil filter on your generator, you **MUST** do steps 1–6 in the *Servicing the System* section and then continue to step 2 in this section.
2. Put the oil drain hose into an approved container.
3. Remove the brass fitting from the end of the oil drain hose.
4. Replace the brass fitting on the hose when the oil has drained.
5. Put an approved container beneath the oil filter area.
6. Remove the oil filter and dispose of it correctly.

7. Before installing a new oil filter, lightly lubricate the oil filter gasket with fresh and clean oil.
8. Install the oil filter by hand until the gasket contacts the oil filter adapter, then tighten the oil filter  $\frac{1}{2}$  to  $\frac{3}{4}$  turn.
9. Add the required amount of oil to bring the level up to (but not over) the “FULL” mark on the dipstick. Install the oil filler cap and wipe up any spilled oil.
10. **After** you change the oil and the oil filter on your generator, you **MUST** do steps 8–15 in the *Servicing the System* section.

## Engine Oil

The engine is filled with full synthetic oil (API SJ/CF 5W-30). This oil allows for system operation in the widest range of temperature and climate conditions.

We recommend the use of Briggs & Stratton® SAE 5W-30 full synthetic engine oil. Other full synthetic high-quality detergent oils are acceptable if classified for service SJ or higher. Do not use special additives.

	<p>An acceptable oil at all temperatures includes full synthetic oil that:</p> <ul style="list-style-type: none"> <li>• Meets International Lubricant Specification Advisory Committee (ILSAC) GF-2 standards</li> <li>• Carries the API certification mark</li> <li>• Features an API service symbol with “SJ/CF energy conserving” or higher</li> </ul> <p>Using full synthetic oil does not alter the required oil change intervals described in the <i>Operation</i> section.</p>
--	---

## Adjust Valve Clearance

The valve lash must be checked every 100 hours of operation. Measure the valve clearance with the engine cold. To adjust the valve clearance, do the steps that follow:

1. **Before** you adjust the valve lash on your generator, you **MUST** do steps 1–6 in the *Servicing the System* section and then continue to step 2 in this section.
2. Remove both spark plugs to ease manual rotation of engine crankshaft.
3. Turn crankshaft counterclockwise until the piston is at *Top Dead Center* on the compression stroke.
4. Set the No. 1 cylinder at  $\frac{1}{4}$  (6mm) past Top Dead Center (TDC) on the compression stroke.
5. Using a feeler gage (A, Figure 24), measure the valve clearance.
6. For proper valve clearance for both the intake and exhaust see *Engine Specifications* Section.
7. Adjust the clearance by loosening the lock nut (B), then turn the adjusting screw (C).
8. Once the clearance is properly set, hold the adjusting screw while torquing the lock nut to 70 in-lbs (8Nm).
9. Repeat these steps for cylinder No. 2.

10. **After** you adjust the valve lash on your generator, you **MUST** do steps 8–15 in the *Servicing the System* section.

24

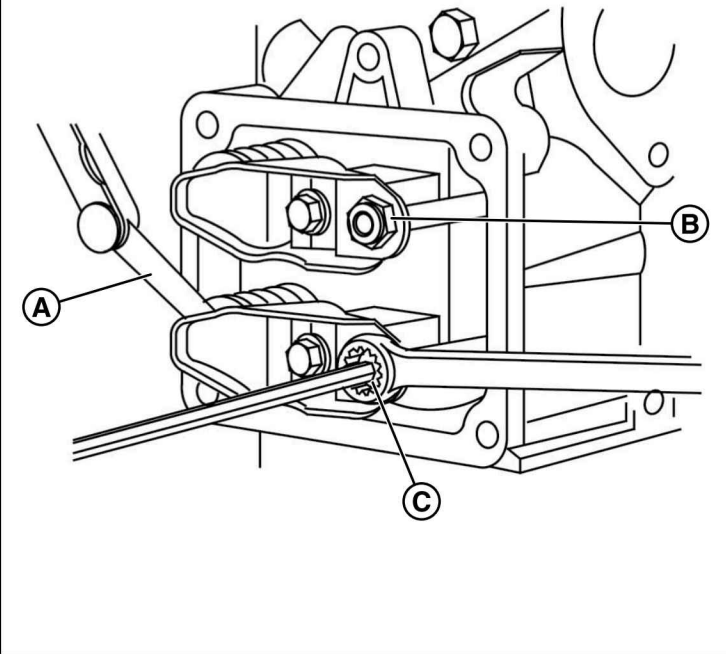

## Electronic Governor System

The engine electronic governor system offers improved control and increased generator performance compared to mechanically governed systems. The result is a smooth steady-state operation without the “hunting” common to many mechanical governors. The system also reduces speed variations under engine loading and unloading and significantly reduces frequency fluctuation when the engine runs under higher loads.

The electronic governor system is composed of a stepper motor (B, Figure 25), stepper motor throttle control linkages (C), and throttle side linkage (A). The generator controller contains a digital controller that processes engine speed information and sends appropriate commands to the stepper motor to control the position of the engine throttle.

Since the electronic governing system controls the engine throttle demand based on generator load, the following service codes and/or conditions could arise from an electronic governing system issue:

- Engine does not start
- Overspeed
- Under-frequency
- Unstable no-load engine control

While troubleshooting any of these conditions, use the controller’s actuator test to initiate a verification of the electronic governor system.

25

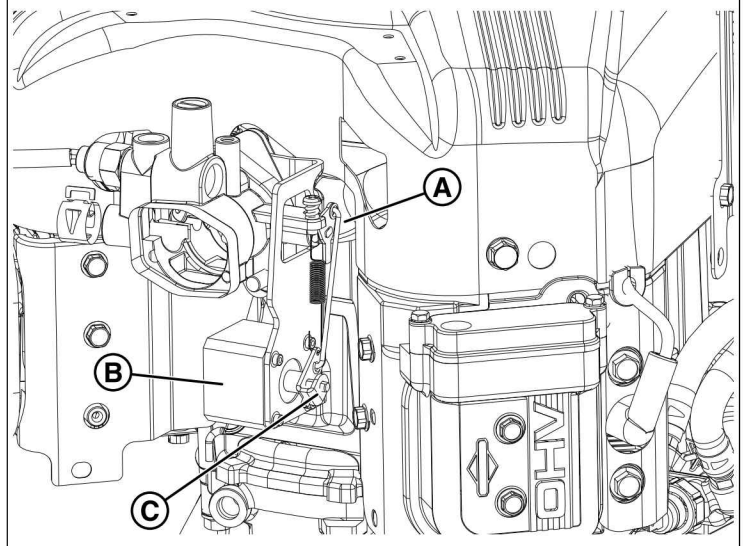

## Electronic Governor Check

The generator has an electronic governing check feature that will turn on the stepper motor and move the throttle linkage clockwise and counterclockwise within the throttle limits. The test will rotate the stepper motor and move the throttle arm between the wide open throttle and dead idle limits for up to ten seconds. This check lets you visually verify whether or not the stepper motor functions correctly and whether or not the control linkages are connected. The engine will not attempt to start during this test. If the stepper motor does not move or if a linkage binds, the generator requires service.

**NOTICE:** If stepper motor does not move, make sure the stepper motor connector is attached.

## Service the Spark Plugs

**WARNING** 

**Accidental engine spark can cause an electric shock, fire or explosion and could result in entanglement, traumatic amputation or laceration.**

**Before you make adjustments or repairs:**

- Disconnect all spark plug wires and keep them away from the spark plugs.
- Disconnect the battery wire from the negative battery terminal (only engines with electric start).
- Use only the correct tools.

**When you check for spark:**

- Use an approved spark plug tester.
- Do not check for spark with the spark plug removed.

Changing the spark plugs will help your engine to start easier and operate better.

1. **Before** you service the spark plugs on your generator, you **MUST** do steps 1–6 in the *Servicing the System* section and then continue to step 2 in this section.
2. Clean the area around spark plugs.

3. Remove and inspect spark plugs.
4. Check electrode gap (A, Figure 26) with wire feeler gauge (B) and reset the spark plug gap to recommended gap if necessary (see *Engine Specifications* section).

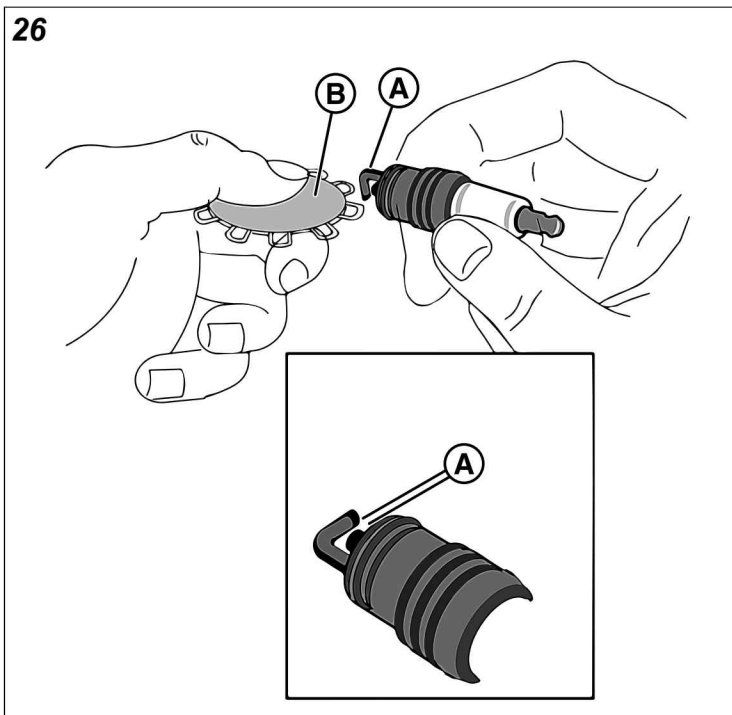

5. Replace the spark plugs if the electrodes are pitted, burned or the porcelain is cracked. Use the recommended replacement spark plugs (see *Engine Specifications* section).
6. Install the spark plugs and tighten them to 180 in-lb (20 N·m).
7. **After** you service the spark plugs on your generator, you **MUST** do steps 8–15 in the *Servicing the System* section.

## Engine Air Cleaner



**WARNING** Gaseous vapors are flammable and explosive. Fire or explosion could result in burns or death.

- Do not start and operate the engine with the air cleaner assembly (if equipped) or the air filter (if equipped) removed.
1. **Before** you service the engine air cleaner on your generator, you **MUST** do steps 1–6 in the *Servicing the System* section and then continue to step 2 in this section.
  2. Remove filter cartridge.

3. Clean the outlet tube and check the dust unloader valve (if equipped). Use a clean cloth to wipe the filter sealing surface and the outlet tube surfaces. Remove all contaminants before inserting the new filter. Do not damage the sealing area on the tube. Check and squeeze the dust unloader valve attached to the service cover and make sure it is flexible and not inverted, damaged, or plugged.
4. Clean the filter. Use a soft bristle brush to loosen dirt and a vacuum cleaner to remove dirt and debris. Replace the filter cartridge if you find any holes in the filter media.
5. Install the clean filter correctly. Insert the filter carefully. Seat the filter by hand, making sure it is completely seated in the air cleaner housing before putting the cover in place.
6. Install the service cover. Make sure that all of the mounting bands, clamps, bolts, and connections in the air cleaner system are tight. Examine the piping for holes and repair them.
7. **After** you service the engine air cleaner on your generator, you **MUST** do steps 8–15 in the *Servicing the System* section.

## Exhaust System Maintenance



**WARNING** Contact with muffler area could cause burns resulting in serious injury.

- DO NOT touch hot parts and AVOID hot exhaust gases.
- Allow equipment to cool before touching.

Check the following when inspecting the exhaust system:

- Inspect the exhaust manifold at the cylinder head for leaks.
- Check that all retaining bolts and shields (if used) are in place.
- Inspect the fasteners between the manifold and the exhaust pipe to make sure they are tight and that there are no exhaust leaks. Repair leaks as necessary.
- Inspect exhaust pipe connection for leaks. Repair leaks as necessary.

It is a violation of California Public Resource Code, Section 4442, to use or operate the engine on any forest-covered, brush-covered, or grass-covered land unless the exhaust system is equipped with a spark arrester, as defined in section 4442, maintained in effective working order. Other states or federal jurisdictions may have similar laws; reference Federal Regulation 36 CFR Part 261.52.

## Fuel System Maintenance



### WARNING

Propane and Natural Gas are extremely flammable and explosive, which could cause burns, fire or explosion resulting in death or serious injury.

- Examine the fuel system periodically.
- NO leakage is permitted.
- DO NOT operate engine if smell of fuel is present.

### Pressure Regulator

The pressure and regulator components have been specifically designed and calibrated to meet the engine's fuel system requirements

If the regulator fails to operate or develops a leak, repair or replace it with the correct OEM recommended replacement parts. When examining the regulator, check the following:

- Check for fuel leaks at the inlet and outlet fittings.
- Check for fuel leaks in the regulator body.
- Make sure the regulator is correctly mounted and that the mounting bolts are tight.
- Examine the regulator for external damage.

## Mixer and Throttle Control Device

The mixer and throttle body components have been specifically designed to meet the engine's fuel system requirements.

A dirty air filter can significantly alter the mixer performance. Make sure the air filter is clean. When you examine the mixer and throttle body, check the following:

- Check for leaks at all the fittings.
- Make sure the mixer and throttle body are securely mounted.
- Examine and clean the air filter element according to the recommended service intervals listed in the *Maintenance Schedule* section.
- Examine the air inlet hose connection and clamp. Examine the hose for cracking, splitting, or chafing. Replace the hose if necessary.
- Examine the fuel lines for cracking, splitting, or chafing. Replace fuel lines if necessary.
- Examine the throttle body and intake manifold for leaks. Replace if necessary.

## Alarms (Service Code Detection System)

The generator operates for long periods of time without an operator present. As a result, the system features sensors that automatically stop the generator in potentially damaging conditions, such as low oil pressure, high temperature, overspeed, and other conditions.

Service alarm descriptions appear in the digital display of the generator's controller.

See the *Alarms* section of the separate online manual titled *Operation Instructions GC1030 Series GENSET Controller* for details on service alarm descriptions.

## Acknowledge and Reset the Alarms

Push the up and down arrows (A, Figure 27) simultaneously to reset the alarm.

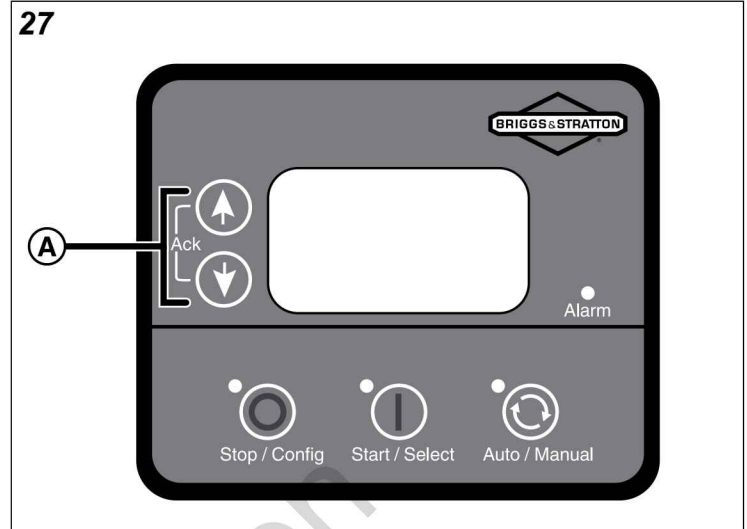

## Electrical System Maintenance

### Wiring and Connections

The electrical system connectors and grounds require good connections. When inspecting the electrical system, check the following:

- Examine the positive (+) and the negative (-) battery cables for corrosion, rubbing, chafing, burning. Make sure that both ends have tight connections.
- Examine the battery for cracks or damage to the case. Replace if necessary.
- Examine the engine wire harness for rubbing, chafing, pinching, burning, and cracks or breaks in the wiring.
- Make sure that the engine harness connectors are correctly locked in.
- Examine the ignition coil wire for hardening, cracking, chafing, burning, separation, and split boot covers.
- Examine the spark plug wires for hardening, cracking, chafing, burning, separation, and split boot covers.
- Replace the spark plugs at the required intervals listed in the *Maintenance Schedule* section.
- Make sure that all electrical components are securely mounted to the engine or chassis.
- Make sure that any additional electrical services installed by the owner are correctly installed in the system.

### Servicing the Battery

A person with a knowledge of batteries and their required precautions must service the battery or supervise the

servicing of the battery. Keep unauthorized personnel away from the batteries.



#### WARNING

Battery electrolyte fluid contains acid and is extremely caustic. Contact with battery contents could cause severe chemical burns.

- DO NOT open or mutilate the battery.
- Wear protective goggles, rubber apron, rubber boots and rubber gloves.
- Immediately wash electrolyte from skin with water.
- If electrolyte contacts eyes, immediately flush with water and seek medical attention.
- Spilled electrolyte is to be washed down with an acid neutralizing agent.
- A common practice is to use a solution of one pound (500 grams) bicarbonate of soda to one gallon (4 liters) of water. The bicarbonate of soda solution is to be added until the evidence of reaction (foaming) has ceased. The resulting liquid is to be flushed with water and the area dried.



#### WARNING

Storage batteries give off explosive hydrogen gas during recharging. Slightest spark could ignite hydrogen and cause explosion, resulting in death or serious injury.

- DO NOT dispose of battery in a fire. Recycle battery.
- DO NOT allow any open flame, spark, heat, or lit cigarette during and for several minutes after charging a battery.
- Discharge static electricity from body before touching batteries by first touching a grounded metal surface.



#### WARNING

A battery's high short circuit current could result in serious injury.

- Remove watches, rings, or other metal objects.
  - Use tools having insulated handles.
  - Disconnect charging source prior to connecting or disconnecting battery terminals.
  - Do not lay tools or metal parts on top of batteries.
  - Disconnect the negative (-) cable at the battery during installation and maintenance.
1. Push the ON/OFF switch to the OFF (0) position (see switch location in the *Features and Controls* section).
  2. Remove utility power to the generator to de-energize the battery charger.
  3. Unlock and open or remove the roof as described in the *Access Panels: Installation and Removal* section.
  4. Remove the 15 amp fuse (see fuse location in the *Features and Controls* section).
  5. Disconnect the negative (-) cable at the battery.

6. Disconnect the positive (+) cable at the battery.
7. Service or replace the battery if necessary.
8. Connect the positive (+) cable at the battery.
9. Connect the negative (-) cable at the battery.
10. Install the 15 amp fuse into the fuse holder (see fuse location in the *Features and Controls* section).
11. Roof and controller: If the generator's controller is located on one of the side panels of the enclosure – install the roof if it was removed (see the *Access Panels: Installation and Removal* section). If the generator's controller is located under the roof – do not close or install the roof yet.
12. Restore utility power to the generator.
13. Push the ON/OFF switch to the ON (I) position (see switch location in the *Features and Controls* section).
14. Access the generator's controller and set the generator mode to AUTO.
15. Close and lock the controller access door or close and lock the roof as described in the *Access Panels: Installation and Removal* section.

**NOTICE** This depends on where the generator's controller is located. See the *Access Panels: Installation and Removal* section.

### Replacing the Battery

When replacing batteries, use the same number and type of batteries. See the *Battery Specifications* chart in the *Battery* section.

1. Push the ON/OFF switch to the OFF (0) position (see switch location in the *Features and Controls* section).
2. Remove utility power to the generator to de-energize the battery charger.
3. Unlock and open or remove the roof as described in the *Access Panels: Installation and Removal* section.
4. Remove the 15 amp fuse (see fuse location in the *Features and Controls* section).
5. Disconnect the negative (-) cable at the battery.
6. Disconnect the positive (+) cable at the battery.
7. Remove the battery and install replacement battery.



DON'T POLLUTE. CONSERVE RESOURCES.  
RETURN USED BATTERY TO RECYCLING  
COLLECTION CENTER.

8. Connect the positive (+) cable at the battery.
9. Connect the negative (-) cable at the battery.
10. Install the 15 amp fuse into the fuse holder (see fuse location in the *Features and Controls* section).
11. Roof and controller: If the generator's controller is located on one of the side panels of the enclosure – install the roof if it was removed (see the *Access Panels: Installation and Removal* section). If the generator's controller is located under the roof – do not close or install the roof yet.



12. Restore utility power to the generator.
13. Push the ON/OFF switch to the ON (I) position (see switch location in the *Features and Controls* section).
14. Access the generator's controller and set the generator mode to AUTO.
15. Close and lock the controller access door or close and lock the roof as described in the *Access Panels: Installation and Removal* section.

**NOTICE** This depends on where the generator's controller is located. See the *Access Panels: Installation and Removal* section.

## Charging the Battery

If it is necessary to charge the battery, proceed as follows:

1. Push the ON/OFF switch to the OFF (O) position (see switch location in the *Features and Controls* section).
2. Remove utility power to the generator to de-energize the battery charger.
3. Unlock and open or remove the roof as described in the *Access Panels: Installation and Removal* section.
4. Remove the 15 amp fuse (see fuse location in the *Features and Controls* section).
5. Disconnect the negative (-) cable at the battery.

**NOTICE** Failure to disconnect negative battery cable could result in equipment failure. DO NOT attempt to jump start the generator. Damage to equipment resulting from failure to follow this instruction will void engine and generator warranty.

6. Charge the battery with the battery charger at 2 amps until the battery holds 12 V. DO NOT exceed 13.7 V when charging the battery.

**NOTICE** DO NOT use a battery booster to quick charge a low battery.

7. Connect the negative (-) cable at the battery.
8. Install the 15 amp fuse into the fuse holder (see fuse location in the *Features and Controls* section).
9. Roof and controller: If the generator's controller is located on one of the side panels of the enclosure – install the roof if it was removed (see the *Access Panels: Installation and Removal* section). If the generator's controller is located under the roof – do not close or install the roof yet.
10. Restore utility power to the generator.
11. Push the ON/OFF switch to the ON (I) position (see switch location in the *Features and Controls* section).
12. Access the generator's controller and set the generator mode to AUTO.
13. Close and lock the controller access door or close and lock the roof as described in the *Access Panels: Installation and Removal* section.

**NOTICE** This depends on where the generator's controller is located. See the *Access Panels: Installation and Removal* section.

Not for  
Reproduction

# Troubleshooting

## Troubleshooting Table

See the *Alarms* section of the separate online manual titled *Operation Instructions GC1030 SERIES GENSET Controller* for details on service alarm description and causes. Call 800-732-2989 or visit [www.briggsandstratton.com](http://www.briggsandstratton.com) for assistance.

PROBLEM	CAUSE	CORRECTION
The engine is running, but no AC output is available.	<ol style="list-style-type: none"> <li>The Circuit breaker is open or defective.</li> <li>An alarm is showing on the controller digital display.</li> <li>The wiring connections are poor or the transfer switch is defective.</li> </ol>	<ol style="list-style-type: none"> <li>Reset or replace circuit breaker.</li> <li>See the separate online manual titled <i>Operation Instructions GC1030 SERIES GENSET Controller</i> for details. Contact the local service facility.</li> <li>Check and repair it or contact local service facility.</li> </ol>
The engine runs well at no-load but "bogs down" when loads are connected.	<ol style="list-style-type: none"> <li>The generator is overloaded.</li> <li>There is a short circuit in a connected load.</li> <li>A generator circuit is shorted.</li> <li>The fuel pressure or mixture is incorrect.</li> <li>The fuel line between regulator and engine is kinked.</li> <li>The air filter is clogged.</li> </ol>	<ol style="list-style-type: none"> <li>Remove one or more loads.</li> <li>Disconnect the shorted electrical load.</li> <li>Contact the local service facility.</li> <li>See the <i>Fuel Installation Plan</i> section in this manual.</li> <li>Remove the kink. Replace the line if necessary.</li> <li>Clean or replace the air filter.</li> </ol>
The engine will not start; or it starts and runs rough.	<ol style="list-style-type: none"> <li>15 amp fuse is missing or blown.</li> <li>The thermal fuse(s) are blown.</li> <li>The fuel supply is turned off or depleted.</li> <li>The fuel selection on the controller and mixer is incorrect.</li> <li>Failed battery.</li> <li>The air filter is clogged.</li> <li>The throttle linkage is binding.</li> </ol>	<ol style="list-style-type: none"> <li>Install a new 15 amp fuse. See the <i>Features and Controls</i> section. Replace the thermal fuse(s).</li> <li>Replace thermal fuse(s).</li> <li>Open the fuel valve(s) and check propane tank.</li> <li>Check the controller profile and set it to the correct profile. Check the mixer screws and set them to the correct positions.</li> <li>Replace the battery.</li> <li>Clean or replace the air filter.</li> <li>Check the linkage.</li> </ol>
The engine shuts down during operation.	<ol style="list-style-type: none"> <li>The fuel supply is turned off or depleted.</li> <li>An alarm is showing on the controller digital display.</li> </ol>	<ol style="list-style-type: none"> <li>Check the fuel valves and fill propane tank.</li> <li>See the separate online manual titled <i>Operation Instructions GC1030 SERIES GENSET Controller</i> for details. Contact the local service facility.</li> </ol>
The circuits lose power.	<ol style="list-style-type: none"> <li>A generator circuit breaker is open.</li> <li>The transfer switch is having problems.</li> </ol>	<ol style="list-style-type: none"> <li>Reset the circuit breaker.</li> <li>See the manual for the transfer switch.</li> </ol>
The unit does not exercise.	<ol style="list-style-type: none"> <li>The control board is not set to AUTO.</li> <li>The exercise timer not set or it is set to OFF.</li> <li>The unit date and time are not set.</li> <li>Failed battery.</li> <li>The 15 amp fuse is missing or blown.</li> </ol>	<ol style="list-style-type: none"> <li>Push the AUTO button on controller.</li> <li>Set the exercise timer.</li> <li>Set the unit date and time.</li> <li>Replace the battery.</li> <li>Install a new 15 amp fuse. See the <i>Features and Controls</i> section.</li> </ol>
The generator undergoes excessive vibration.	<ol style="list-style-type: none"> <li>A mechanical fastener is loose.</li> </ol>	<ol style="list-style-type: none"> <li>Check and repair it or contact the local service facility.</li> </ol>
An odor of fuel is present.	<ol style="list-style-type: none"> <li>Fuel leak.</li> </ol>	<ol style="list-style-type: none"> <li>Turn off the manual shutoff fuel valve. Contact the local service facility.</li> </ol>
Utility power returns and unit does not stop.	<ol style="list-style-type: none"> <li>Fuses are blown in the transfer switch.</li> <li>The five-minute cooldown is still in process.</li> <li>Wire connection are poor or the controllers are defective.</li> </ol>	<ol style="list-style-type: none"> <li>Install new fuses.</li> <li>Wait five minutes.</li> <li>Inspect and repair the unit or contact the local service facility.</li> </ol>

<b>PROBLEM</b>	<b>CAUSE</b>	<b>CORRECTION</b>
Possible issues in MANUAL MODE.	-	See the <i>Common Faults and Their Remedial Actions</i> table inside the separate online manual titled <i>Operation Instructions GC1030 SERIES GENSET Controller</i> for details.
Possible issues in AUTO MODE.	-	See the <i>Common Faults and Their Remedial Actions</i> table inside the separate online manual titled <i>Operation Instructions GC1030 SERIES GENSET Controller</i> for details.
Possible issues with Electronic Governing.	-	See the <i>Common Faults and Their Remedial Actions</i> table inside the separate online manual titled <i>Operation Instructions GC1030 SERIES GENSET Controller</i> for details.

Not for  
Reproduction

# Wiring Diagram and Schematic

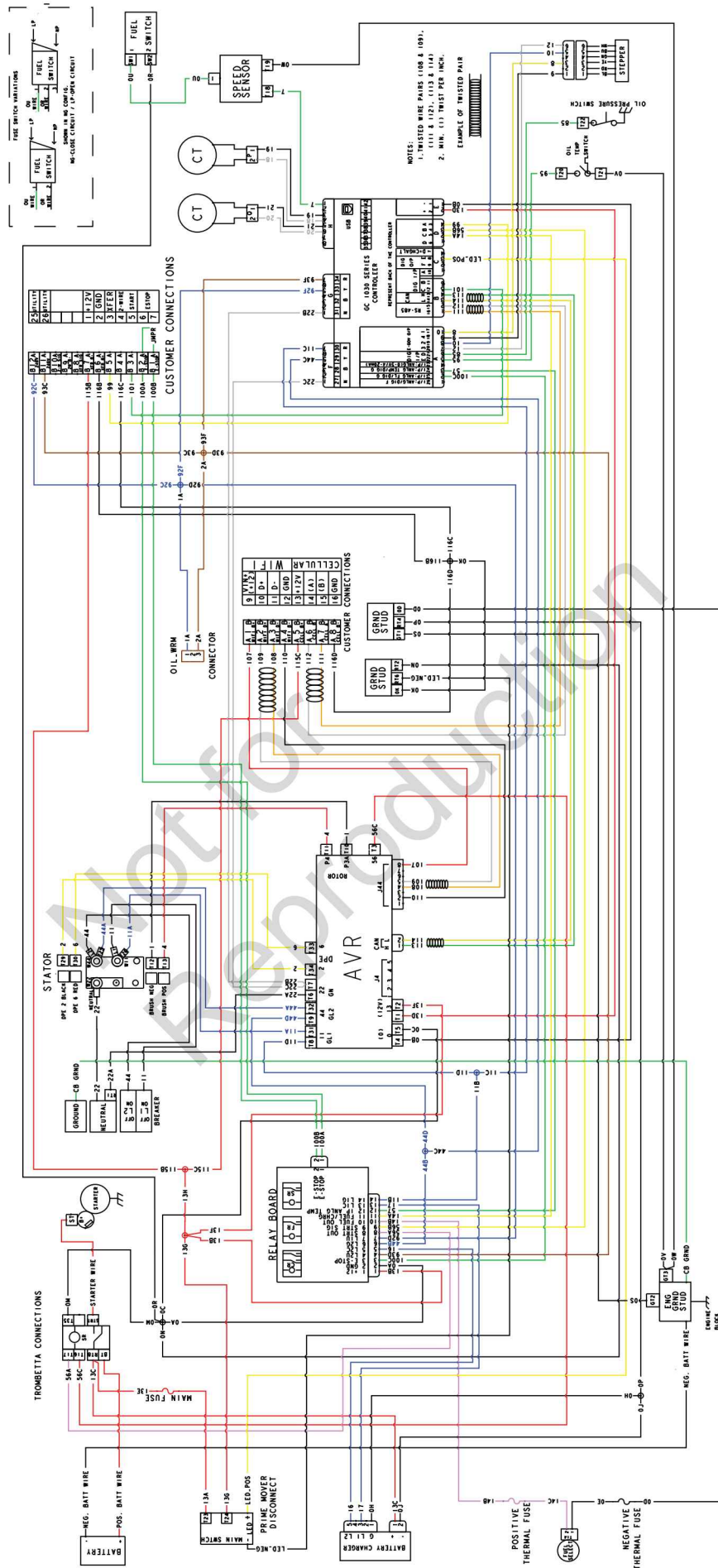



# Specifications

## Generator Specifications 13kW

Rated Maximum Load Current (at 25°C/77°F, LP) at 240 Volts	54.2 Amps	
Rated AC Voltage	120/240 Volts	
Phase	Single Phase	
Rated Frequency	60 Hertz	
Generator Breaker	70 Amp	
Normal Operating Range	-20 °F (28 °C) to 104 °F (40 °C)	
Sound Rating *	Low Idle Mode	64 db(A)
	Normal Operation	70 db(A)
Shipping Weight	370 lb (168 kg)	

\* Per ISO 3744. Lowest mic at 23 ft (7m) at indicated load.

## Engine Specifications 13kW

Displacement	38.26 ci. (627 cc)
Bore	2.972 in. (75.5 mm)
Stroke	2.756 in. (70 mm)
Spark Plug Gap	0.020 in. (0.51 mm)
Spark Plug Torque	180 lb-in. (20 Nm)
Armature Air Gap	0.008 - 0.012 in. (0.20 - 0.30 mm)
Intake Valve Clearance	0.004 - 0.006 in. (0.10 - 0.15 mm)
Exhaust Valve Clearance	0.007 - 0.009 in. (0.15 - 0.23 mm)
Oil Type	5W30 Full Synthetic
Oil Capacity (with filter)	42 - 45 oz. (1.24 - 1.33 L)
Engine End Cover Bolt	220 lb-in (25Nm)