



POWERHORSE[®]

PPW2300

Item# 106168

EN

PRESSURE WASHER

OPERATOR MANUAL

ES

LAVADORA A PRESIÓN

MANUAL DEL OPERADOR



PWA203

www.northerntool.com

Thank you very much for choosing an Powerhorse® product!
¡Muchas gracias por elegir un producto Powerhorse®!

For future reference, please complete the owner's record below:
Para consultas posteriores, cumplimente el registro del propietario que figura a continuación:

Serial Number/Lot Date Code: _____

Número de serie/código de fecha de lote: _____

Purchase Date: _____

Fecha de compra: _____

Save the receipt, warranty, and this manual. It is important that you read the entire manual to become familiar with this product before you begin using it.

Conserve el justificante de compra, la garantía y este manual. Es importante que lea todo el manual para familiarizarse con este producto antes de empezar a usarlo.

This pressure washer is designed for certain applications only. Northern Tool and Equipment is not responsible for issues arising from modification or improper use of this product such as an application for which it was not designed. We strongly recommend that this product not be modified and/or used for any application other than that for which it was designed.

Este limpiador a presión se ha diseñado únicamente para determinadas aplicaciones. Northern Tool and Equipment no se hace responsable de los problemas derivados de la modificación o el uso indebido de este producto, como una aplicación para la que no fue diseñado. Recomendamos encarecidamente que este producto no se modifique ni se utilice para ninguna otra aplicación que no sea para la que fue diseñado.

For technical questions, please call **1-866-915-9824**.

En caso de cuestiones técnicas, llame al **1-866-915-9824**.

1	Description.....	4	3.7	Install the upper handle.....	8
1.1	Purpose.....	4	3.8	Install the wheels.....	8
1.2	Overview.....	4	3.9	Install the spray wand.....	8
2	General power tool safety warnings.....	4	3.10	Install the high pressure hose.....	8
2.1	General power tool safety warnings.....	4	4	Operation.....	9
2.2	Electrical safety warnings.....	4	4.1	Connect the water supply to the machine.....	9
2.3	Pressure washer safety warnings.....	5	4.2	Use the spray gun.....	9
2.4	Ground fault circuit interrupter protection.....	5	4.3	Change the spray tip.....	10
2.5	Servicing of a double-insulated appliance.....	5	4.4	Add detergent.....	11
2.6	Extension cords.....	5	4.5	Start the machine.....	11
2.7	Child safety.....	5	4.6	Stop the machine.....	11
2.8	Symbols on the product.....	5	5	Maintenance.....	11
2.9	Risk levels.....	6	5.1	Spray tip maintenance.....	12
2.10	Proposition 65.....	6	6	Transportation and storage.....	12
3	Installation.....	6	6.1	Move the machine.....	12
3.1	Electrical connection.....	6	6.2	Store the machine.....	12
3.2	Unpack the machine.....	7	7	Troubleshooting.....	13
3.3	Install the upper panel.....	7	8	Technical data.....	14
3.4	Install the hose hook.....	7	9	Limited warranty.....	14
3.5	Install the spray gun holder.....	7	10	Exploded view.....	15
3.6	Install the power cord storage arm.....	8			

1 DESCRIPTION

1.1 PURPOSE

The machine is used to clean vehicles, boats, buildings, porches, decks, patios, and driveways.

For residential use only, not for professional use, and for operation at temperature above 32°F (0°C). The pressure washer is to be used only for its prescribed purpose, any other use is deemed to be a case of misuse. The user/operator and not the manufacturer will be liable for any damage or injuries of any kind caused as a result of this. Note that our equipment has not been designed for use in commercial, trade, or industrial applications. Our warranty will be voided if the pressure washer is used in commercial, trade, or industrial businesses or for equivalent purposes.

1.2 OVERVIEW

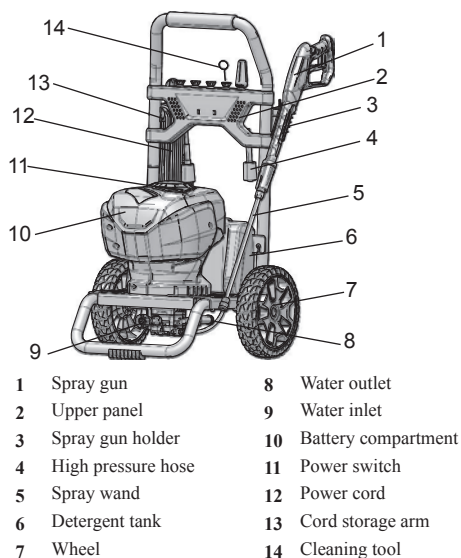

2 GENERAL POWER TOOL SAFETY WARNINGS

▲ WARNING

When using this product basic precautions should always be followed, including the following:

Save all warnings and instructions for future reference.

The term “power tool” in the warnings refers to your mains-operated (corded) power tool.

2.1 GENERAL POWER TOOL SAFETY WARNINGS

- The machine is not intended for use by persons (including children) with reduced physical, sensory or mental capabilities, or lack of experience and knowledge, unless they have been given supervision or instruction concerning use of the machine by a person responsible for their safety. Children should be supervised to ensure that they do not play with the machine.
- Learn the machine's applications and limitations as well as the specified potential hazards related to this tool by studying this manual.
- Never operate the machine with any guard or cover removed or damaged.
- Do not operate the product while under the influence of drugs, alcohol, or any medication.
- Do not wear loose clothing, gloves, neckties, or jewelry. They can get caught and draw you into moving parts.
- Rubber gloves and non-skid footwear are recommended when working outdoors. Also wear protective hair covering to contain long hair. Wear footwear that will protect your feet and improve your grip on slippery surfaces.
- Don't overreach or stand on unstable support. Keep proper footing and balance at all times.
- Check the work area before each use. Remove all objects such as rocks, broken glass, nails, wire, or string which can be thrown or become entangled in the machine.
- Avoid dangerous environments. Don't expose to rain. Keep work area well lit.
- Before starting any cleaning operation, close doors and windows. Clear the area to be cleaned of debris, toys, outdoor furniture, or other objects that could create a hazard.
- Don't use the appliance within range of persons unless they wear protective clothing.

2.2 ELECTRICAL SAFETY WARNINGS

- Disconnect from the electrical power supply before carrying out user maintenance.
- Use only extension cords that have watertight connections and are intended for outdoor use. Use only extension cords having an electrical rating not less than the rating of the product. Examine extension cord before using and replace if damaged. Do not abuse extension cord and do not pull on any cord to disconnect. Keep cord away from heat and sharp edges. Always disconnect the extension cord from the receptacle before disconnecting the product from the extension cord.
- Do not use the machine if a supply cord or important parts of the appliance are damaged, e.g. safety devices, high pressure hoses, trigger gun.
- Inadequate extension cords can be dangerous.
- To reduce the risk of electrocution, keep all connections dry and off the ground. Do not touch plug with wet hands.

- Do not abuse the cord. Never use the cord to carry the product or to disconnect the plug from an outlet. Keep cord away from heat, oil, sharp edges, or moving parts. Replace damaged cords immediately. Damaged cords increase the risk of electric shock.
- Inspect extension cords periodically and replace if damaged. Keep handles dry, clean, and free from oil or grease.

2.3 PRESSURE WASHER SAFETY WARNINGS

- Read all the instructions before using the product.
- To reduce the risk of injury, close supervision is necessary when a product is used near children.
- Know how to stop the product and bleed unit pressure quickly. Be thoroughly familiar with the controls.
- Stay alert – watch what you are doing.
- Do not operate the product when fatigued or under the influence of alcohol or drugs.
- Keep operating area clear of all persons.
- Do not overreach or stand on unstable support. Keep good footing and balance at all times.
- Follow the maintenance instructions specified in the manual.
- This product is provided with a ground fault circuit interrupter built into the power cord plug. If replacement of the plug or cord is needed, use only identical replacement parts.
- Risk of injection or injury– Do not direct discharge stream at persons.
- Keep the motor away from flammables and other hazardous materials.
- Keep product dry, clean, and free from oil and grease. Always use a clean cloth when cleaning. Never use brake fluids, gasoline, petroleum-based products, or any solvents to clean product.

▲ WARNING

To reduce the risk of electrocution, keep all connections dry and off the ground. Do not touch plug with wet hands.

2.4 GROUND FAULT CIRCUIT INTERRUPTER PROTECTION

This pressure washer is provided with a ground-fault circuit-interrupter (GFCI) built into the plug of the power-supply cord. This device provides additional protection from the risk of electric shock. Should replacement of the plug or cord become necessary, use only identical replacement parts that include GFCI protection.

2.5 SERVICING OF A DOUBLE-INSULATED APPLIANCE

- Within a double-insulated product, two systems of insulation are provided instead of grounding. No

grounding means is provided on a double-insulated product, nor should a means for grounding be added to the product. Servicing a double-insulated product requires extreme care and knowledge of the system, and should be done only by qualified service personnel. Replacement parts for a double-insulated product must be identical to the parts they replace. A double-insulated product is marked with the words “DOUBLE INSULATION” or “DOUBLE INSULATED.”

2.6 EXTENSION CORDS

- Use only extension cords that are intended for outdoor use. These extension cords are identified by a marking “Acceptable for use with outdoor appliances; store indoors while not in use.” Use only extension cords having an electrical rating not less than the rating of the product. Do not use damaged extension cords. Examine extension cord before using and replace if damaged. Do not abuse extension cord and do not yank on any cord to disconnect. Keep cord away from heat and sharp edges. Always disconnect the extension cord from the receptacle before disconnecting the product from the extension cord.



2.7 CHILD SAFETY









Tragic accidents can occur if the operator is not aware of the presence of children.

- Keep children out of the working area and under the watchful care of a responsible adult.
- Do not allow children under the age of 14 to operate this machine. Children who are 14 years of age and older must read and understand the operating instructions and safety rules in this manual and must be trained and supervised by a parent.
- Stay alert, and turn the machine off if a child or any other person enters the working area.
- Use extreme care when approaching blind corners, doorways, shrubs, trees, or other objects that may obscure your view of a child who may run into the path of the machine.

2.8 SYMBOLS ON THE PRODUCT



Some of the following symbols may be used on this tool. Please study them and learn their meaning. Proper interpretation of these symbols will allow you to operate the tool better and safer.

Symbol	Explanation
	To reduce the risk of injury, user must read and understand operator's manual before using this product.
	Do not expose the product to rain or moist conditions.

Symbol	Explanation
	Always wear safety goggles or safety glasses with side shields and, as necessary, a full face shield when operating this product.
	To reduce the risk of injection or injury, never direct a water stream towards people or pets or place any body part in the stream. Leaking hoses and fittings are also capable of causing injection injury. Do not hold hoses or fittings.
	To reduce the risk of injury from kickback, hold the spray lance securely with both hands when the machine is on.
	Failure to use in dry conditions and to observe safe practices can result in electric shock.
	Fuel and its vapors are explosive and can cause severe burns or death.
	Warning! Never point the gun to human, animals, the machine body, power supply or any electric appliances.
	Appliance not suitable for connection to the drinking water mains without backflow preventer.
	Only use cleaning deck on flat, horizontal surfaces. Never lift cleaning deck from the cleaning surface while operating the pressure washer.
	Keep hands and feet away from the cleaning deck while the pressure washer is running.

2.9 RISK LEVELS

The following signal words and meanings are intended to explain the levels of risk associated with this product.

SYMBOL	SIGNAL	MEANING
	DANGER	Indicates an imminently hazardous situation, which, if not avoided, will result in death or serious injury.
	WARNING	Indicates a potentially hazardous situation, which, if not avoided, could result in death or serious injury.

SYMBOL	SIGNAL	MEANING
	CAUTION	Indicates a potentially hazardous situation, which, if not avoided, may result in minor or moderate injury.
	CAUTION	(Without Safety Alert Symbol) Indicates a situation that may result in property damage.

2.10 PROPOSITION 65

▲ WARNING

This product contains a chemical known to the state of California to cause cancer, birth defects or other reproductive harm. Some dust created by power sanding, sawing, grinding, drilling, and other construction activities contains chemicals known to cause cancer, birth defects or other reproductive harm. Some examples of these chemicals are:

- Lead from lead-based paints;
- Crystalline silica from bricks and cement and other masonry products;
- Arsenic and chromium from chemically treated lumber.

Your risk of exposure to these chemicals varies depending on how often you do this type of work. To reduce your exposure to these chemicals, work in a well-ventilated area, and work with approved safety equipment, such as dust masks that are specially designed to filter out microscopic particles.

Save these instructions.

3 INSTALLATION

3.1 ELECTRICAL CONNECTION

This machine has a precisely built electrical motor. It should be connected to a power supply that is 120V, 60 Hz, AC only (household). Do not operate this machine on direct current (DC). A considerable voltage drop will cause a loss of power and the motor will be overheated.

3.1.1 PREPARE A DRIP LOOP

Recommend the use of a drip loop as below so the water can not run along the power cord even possibly reach the electrical outlet and plug.

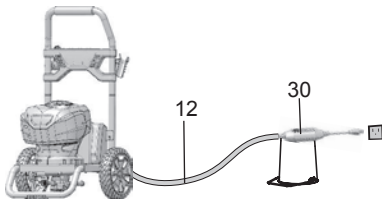

▲ WARNING

Keep the extension cord clear of the working area. Position the cord so that it will not get caught on lumber, tools, or other obstructions while you are working with a power tool. Failure to do so can result in serious personal injury.

3.2 UNPACK THE MACHINE

▲ WARNING

Make sure that you correctly assemble the machine before use.

▲ WARNING

- If parts of the machine are damaged, do not use the machine.
- If you do not have all the parts, do not operate the machine.
- If parts are damaged or missing, contact the service center.

1. Open the package.
2. Read the documentation provided in the box.
3. Remove all the unassembled parts from the box.
4. Remove the machine from the box.
5. Discard the box and packing material in compliance with local regulations.

3.3 INSTALL THE UPPER PANEL

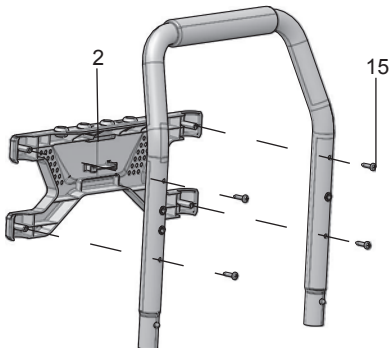

1. Align the screw sleeves of the upper panel (2) with the screw holes on the upper handle.

2. Push the screws (15) through the screw sleeves and tighten them.

3.4 INSTALL THE HOSE HOOK

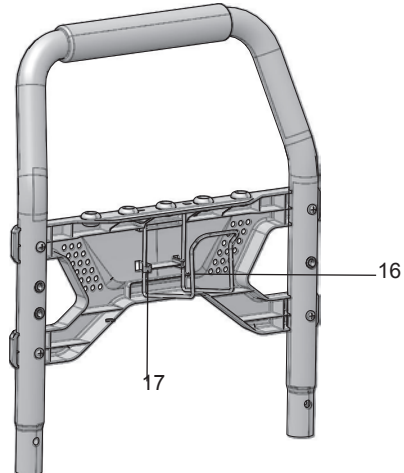

1. Push the hose hook (16) ends into the clips (17) behind the front panel tightly.

3.5 INSTALL THE SPRAY GUN HOLDER

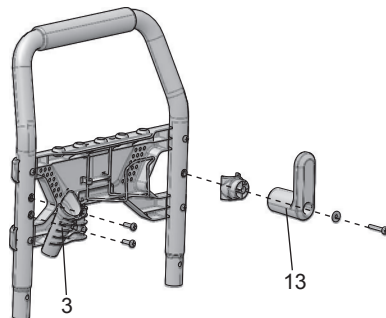

1. Align the screw sleeves of the spray gun holder (3) with the screw holes on the upper handle.
2. Push the screws (15) through the screw sleeves and tighten them.

3.6 INSTALL THE POWER CORD STORAGE ARM

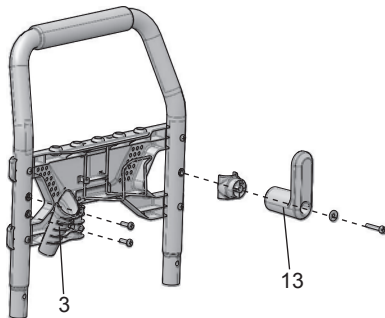

1. Attach the power cord storage arm (13) onto the fixture.
2. Align the screw (15) with the hole in the power cord storage arm (13).
3. Push the screw (15) through and tighten it.

3.7 INSTALL THE UPPER HANDLE

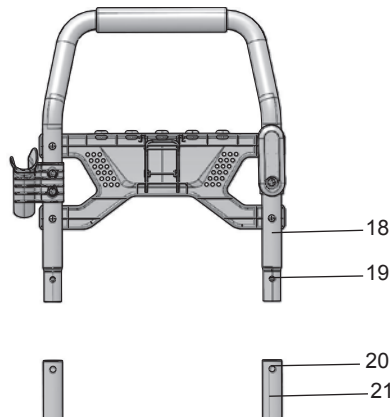

1. Push and hold the handle lock button (19) on the upper handle (18).
2. Move the upper handle (18) into the lower handle (21) until the handle lock button (19) clicks through the slot (20).

3.8 INSTALL THE WHEELS

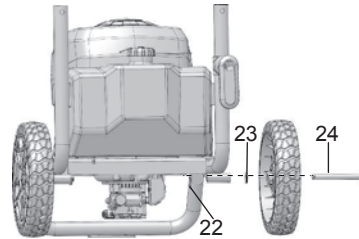

1. Place axle (24) through the wheel and handle frame.
2. Place washer (23) onto the axle (24).
3. Insert cotter pin (22) through the hole of the axle (24).

3.9 INSTALL THE SPRAY WAND

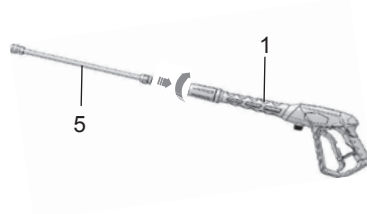

1. Push the end of the spray wand (5) into the gun handle (1).
2. Turn the spray wand (5) clockwise until the tabs lock into position.

▲ WARNING

Make sure that the connection has no leakage.

3.10 INSTALL THE HIGH PRESSURE HOSE

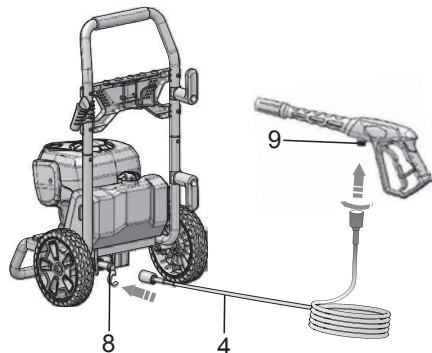

1. Push and turn clockwise one end of the high pressure hose (4) into the inlet coupler (9).

2. Install and tighten the other end of the high pressure hose onto the water outlet (8) coupler.

4 OPERATION

▲ WARNING

Make sure that all the connections are tight and have no leakage before operation.

4.1 CONNECT THE WATER SUPPLY TO THE MACHINE

For easy operation, please use a self-coiling garden hose (not provided).

▲ WARNING

When you operate the self-coiling hose, make sure that the hose has no blockage.

▲ WARNING

- The water supply must come from the water main
- Do not use hot water
- Do not use water from ponds or lakes

▲ WARNING

Do the local regulations when you connect the garden hose to the water supply. Direct connection through a receiver tank or backflow preventer is usually permitted.

▲ CAUTION

Inspect the filter in the water inlet connector before you connect the garden hose

- If the filter is damaged, do not use the machine until the filter is replaced.
- If the filter is dirty, clean the filter.

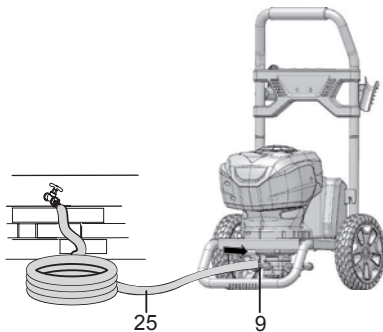

1. Uncoil the garden hose (25).
2. Let the water flow through the garden hose (25) for 30 seconds.

3. Turn the water supply off.
4. Install and tighten the end of the garden hose (25) to the water inlet (9) connector.

▲ CAUTION

There must be a minimum of 3 m of free hose between the water inlet and the water supply.

4.2 USE THE SPRAY GUN

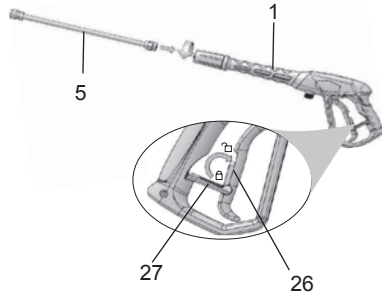

▲ WARNING

For safe control, keep your hands on the gun at all times.

- Pull and hold the spray gun trigger (26) to start the machine.
- Release the spray gun trigger (26) to stop water flow through the spray tip (28).

4.2.1 UNLOCK THE GUN TRIGGER

- Push the trigger safety lock-out (27) down until it clicks into the slot.

4.2.2 LOCK THE GUN TRIGGER

- Push the trigger safety lock-out (27) up and into it's original position.

4.3 CHANGE THE SPRAY TIP

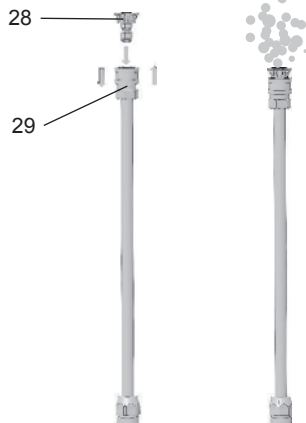

▲ WARNING

Before you change the spray tip:

1. Pull the spray gun trigger to release water pressure.
2. Engage the trigger safety lock-out on the spray gun.
3. Stop the machine.

▲ WARNING

Do not point the spray wand at your face or others'.

4.3.1 NOZZLE TYPE

SPRAY TIP	APPLICATION
	<p>Yellow - Narrow fan tip (15°)</p> <ul style="list-style-type: none"> The yellow pressure washer tip provides high versatility with its 15 degree angle tip. Referred to as the washing tip, because it provides adequate pressure to remove dirt from surfaces, but is designed to not damage many surfaces. This pressure washer tip is designed for “sweeping” foliage or debris given its wide angle. This tip is versatile due to its wide area of cleaning and strong pressure application.

SPRAY TIP	APPLICATION
	<p>Green - Narrow fan tip (25°)</p> <ul style="list-style-type: none"> The green pressure washer tip provides high versatility with its 25 degree angle tip. Referred to as the washing tip, because it provides adequate pressure to remove dirt from surfaces, but is designed to not damage many surfaces. This pressure washer tip is designed for “sweeping” foliage or debris given its wide angle. This tip is versatile due to its wide area of cleaning and strong pressure application.
	<p>White - Wide fan tip (40°)</p> <ul style="list-style-type: none"> The white 40 degree tip, referred to as the “fan” tip creates the widest area of cleaning with relatively low pressure. This pressure washer tip is best used for light or delicate cleaning applications. It is recommended for light cleaning on wood decks and other soft or delicate surfaces.
	<p>Black - Soap spray tip</p> <ul style="list-style-type: none"> The black soap spray tip, is used for soap application. Soap is applied under low pressure high volume for optimum performance. Soap cannot be applied under high pressure with this machine.
	<p>Turbo nozzle tip</p> <ul style="list-style-type: none"> The nozzle rotates in a zero to 15 degree spray pattern in a circular motion to break down tough dirt and grime. The spray pattern can cover area of 4 to 8 inches wide, depending on a distance between the tip and the surface being cleaned.

4.3.2 INSTALL THE SPRAY TIP

1. Pull back the quick-connect collar (29) on the spray wand (5).
2. Insert the spray tip (28) onto the spray wand (5).
3. Release the quick-connect collar (29) to attach the spray tip (28).
4. Pull on spray tip (28) to ensure it is properly installed and does not pull out.

4.4 ADD DETERGENT

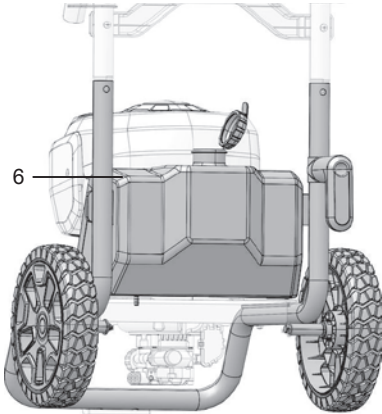

▲ WARNING

Do not use household detergents, acids, alkalines, bleaches, solvents, flammable material, or industrial grade solutions, which can do damage to the pump.

▲ WARNING

Do the instructions on the solution bottle to prepare detergent.

i NOTE

If it is necessary, use a funnel to prevent the spill of detergent. Clean and dry the spilled detergent when you fill it.

i NOTE

Soap/detergent can only be applied with this machine when the black nozzle(75 degree) is installed.

1. Put the machine vertically on a flat surface.
2. Open the cap on the detergent tank (6).
3. Put the detergent into the detergent tank (6).
4. Close the cap.

i NOTE

Do not let detergent dry on the surface to prevent streaks.

4.5 START THE MACHINE

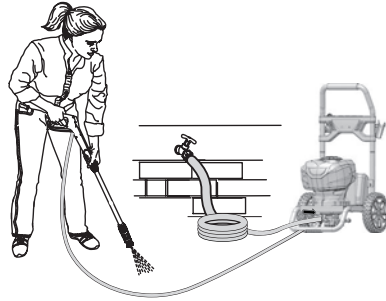

▲ CAUTION

Do not operate without the water supply connected.

▲ CAUTION

Before you start the machine:

1. Turn the water supply on.
2. Pull the gun trigger to release air pressure.
3. If a stable stream of water come into view, release the spray gun trigger.

1. Connect the machine to the power supply.
2. Set the power switch to the "ON" (I) position.
3. Turn the water supply on.
4. Pull the spray gun trigger.

4.6 STOP THE MACHINE

1. Release the spray gun trigger.
2. Press down on the ON/OFF switch, once again, to set the power switch to the "OFF" (O) position.

▲ WARNING

If you do not use the machine :

- Stop the machine.
- Turn the water supply off.
- Disconnect the power cord from the outlet.
- Pull the spray gun trigger to release the remaining pressure from the machine.
- Engage the trigger safety lock-out on the spray gun.

5 MAINTENANCE

▲ WARNING

Before maintenance, make sure that you

- Stop the machine.
- Wait until all the moving parts stop.
- Disconnect the plug from the power source.

▲ WARNING

Do not use strong solvents or detergents on the plastic housing or components.

▲ WARNING

Do not let brake fluids, gasoline, petroleum-based materials touch the plastic parts. Chemicals can cause damage to the plastic, and make the plastic unserviceable.

▲ WARNING

Replace the power cord by an approved service center.

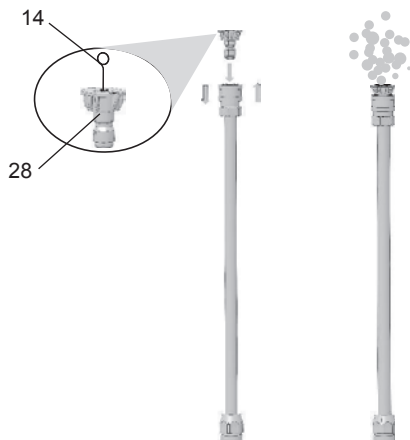
5.1 SPRAY TIP MAINTENANCE

If there is too much pump pressure, the spray tip can become clogged, you can feel a pulsing sensation while you pull the spray gun trigger.

5.1.1 REMOVE THE SPRAY TIP

1. Pull back the quick-connect collar (29) on the spray wand (5).
2. Remove the spray tip (28) from the spray wand (5).

5.1.2 CLEAN THE SPRAY TIP

1. Use a straight paper clip or cleaning tool (14) to clean the spray tip.
2. Flush and clean the unwanted materials out of the spray tip (28) with the garden hose (25).
3. Install the clean spray tip (28) to the spray wand (5).

6 TRANSPORTATION AND STORAGE**▲ WARNING**

Disconnect the power cord and water supply hose before transportation and storage.

6.1 MOVE THE MACHINE

- Point the spray wand in a safe direction.
- Only hold the machine with the handgrip.

6.2 STORE THE MACHINE**▲ WARNING**

Make sure that the spray gun, the high pressure hose and the pump are dry.

▲ WARNING

Make sure the machine is out of the reach of children.

i NOTE

Use a recommended pump protector to prevent cold weather damage during storage in winter.

- Disconnect the garden hose from machine.
- Wind the power cord and the high pressure hose.
- Clean housing and the plastic components with a moist and soft cloth.
- Make sure that the machine does not have loose or damaged parts. If it is necessary, follow these steps/instructions:
 - Replace the damaged parts.
 - Tighten the bolts.
 - If needed, call the customer service phone number (enter number here) for servicing instructions.
- Store the machine in a dry, isolated and frost-free area.

7 TROUBLESHOOTING

PROBLEM	POSSIBLE CAUSE	SOLUTION
The motor does not start.	The power button is in the "OFF" (O) position.	Set the power switch to the "ON" (I) position.
	The power cord is not plugged in.	Connect the power cord to the power supply.
	Electrical outlet does not supply sufficient power.	Try another electrical outlet.
	The circuit breaker is tripped.	Let it cool, and start the machine again.
	The power switch is on, but you do not pull the spray gun trigger.	Pull the spray gun trigger.
The machine does not reach high pressure.	The diameter of garden hose is too small.	Replace with a 1" (25 mm) or 5/8" (16 mm) garden hose.
	Water supply is restricted.	Check garden hose for kinks, leaks, and blockage.
	The water supply is not sufficient.	Open the water supply fully.
	Spray tip has not be installed onto the spray wand properly.	Install desired spray tip to end of wand.
	The water intake filter is clogged.	Remove filter and rinse in warm water.

PROBLEM	POSSIBLE CAUSE	SOLUTION
The output pressure varies high and low.	The water supply is not sufficient.	Open water supply fully. Check garden hose for kinks, leaks, or blockage.
	The pump is drawing in air.	<ol style="list-style-type: none"> 1. Make sure that the hoses and fitting are airtight. 2. Turn "OFF" machine. 3. Purge pump by squeezing trigger gun until a steady flow of water comes out the spray tip.
	The water intake filter is clogged.	Remove the filter and Rinse in warm water.
	The supply voltage is low.	Make sure that only the pressure washer is running on the circuit.
	The gun, hose or nozzle are calcified.	Run distilled vinegar through detergent tank.

PROBLEM	POSSIBLE CAUSE	SOLUTION
The motor buzzes, but the machine does not start.	The supply voltage is low.	Make sure that only the pressure washer is running on the circuit.
	The pump system has residual pressure.	<ol style="list-style-type: none"> 1. Turn "OFF" the machine. 2. Pull the spray gun trigger on spray wand to release pressure. 3. Turn the machine "ON".
	Voltage loss due to use of an improper extension cord.	Disconnect the extension cord, and connect the machine directly into the outlet.
	Pressure washer not used for long periods.	Call customer service.
	Residual friction among components. Unit might emit a humming noise.	<ol style="list-style-type: none"> 1. Disconnect the water supply. 2. Power "ON" the machine for 2 to 3 seconds. 3. Repeat the above step a couple of times or until the motor starts.
There is no water.	The water supply is off.	Turn the water supply on.
	The garden hose is kinked..	Remove kink in garden hose.

8 TECHNICAL DATA

Universal Motor	120V~ 60 Hz, 14 Amps
Max. Pounds Per Square Inch Pressure	2300 PSI
Rated Gallons Per Minute	1.2 GPM
Maximum Inlet Water Temperature	104 °F (40 °C)
Cleaning Units	2760 C.U.
Weight	41.2 lbs. (18.7 kg)
Detergent injection rate	3%~12%



Double-insulated construction.

9 LIMITED WARRANTY

Northern Tool and Equipment Company, Inc. ("We" or "Us") warrants to the original purchaser only ("You" or "Your") that the Powerhorse product purchased will be free from material defects in both materials and workmanship, normal wear and tear excepted, for a period of two years from date of purchase. The foregoing warranty is valid only if the installation and use of the product is strictly in accordance with product instructions. There are no other warranties, express or implied, including the warranty of merchantability or fitness for a particular purpose. If the product does not comply with this limited warranty, Your sole and exclusive remedy is that We will, at our sole option and within a commercially reasonable time, either replace the product or product component without charge to You or refund the purchase price (less shipping). This limited warranty is not transferable.

Limitations on the Warranty

This limited warranty does not cover: (a) normal wear and tear; (b) damage through abuse, neglect, misuse, or as a result of any accident or in any other manner; (c) damage from misapplication, overloading, or improper installation; (d) improper maintenance and repair; and (e) product alteration in any manner by anyone other than Us, with the sole exception of alterations made pursuant to product instructions and in a workmanlike manner.

Obligations of Purchaser

You must retain Your product purchase receipt to verify date of purchase and that You are the original purchaser. To make a warranty claim, contact Us at 1-866-915-9824, identify the product by make and model number, and follow the claim instructions that will be provided. The product and the purchase receipt must be provided to Us in order to process Your warranty claim. Any returned product that is replaced or refunded by Us becomes our property. You will be responsible for return shipping costs or costs related to Your return visit to a retail store.

Remedy Limits

Product replacement or a refund of the purchase price is Your sole remedy under this limited warranty or any other warranty related to the product. We shall not be liable for: service or labor charges or damage to Your property incurred in removing or replacing the product; any damages, including, without limitation, damages to tangible personal property or personal injury, related to Your improper use, installation, or maintenance of the product or product component; or any indirect, incidental or consequential damages of any kind for any reason.

Assumption of Risk

You acknowledge and agree that any use of the product for any purpose other than the specified use(s) stated in the product instructions is at Your own risk.

Governing Law

This limited warranty gives You specific legal rights, and You also may have other rights which vary from state to state. Some states do not allow limitations or exclusions on implied warranties or incidental or consequential damages, so the above limitations may not apply to You. This limited warranty is governed by the laws of the State of Minnesota, without regard to rules pertaining to conflicts of law. The state courts located in Dakota County, Minnesota shall have exclusive jurisdiction for any disputes relating to this warranty.

10 EXPLODED VIEW

Replacement Parts

- i. For replacement parts and technical questions, please call Customer Service at 1-866-915-9824.
- ii. Not all product components are available for replacement. The illustrations provided are a convenient reference to the location and position of parts in the assembly sequence.
- iii. When ordering parts, the following information will be required: item description, item model number, item serial number/ item lot date code, and the replacement part reference number.
- iv. The distributor reserves the rights to make design changes and improvements to product lines and manuals without notice.

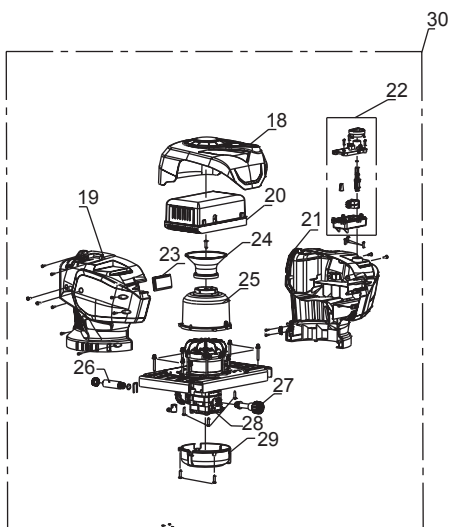
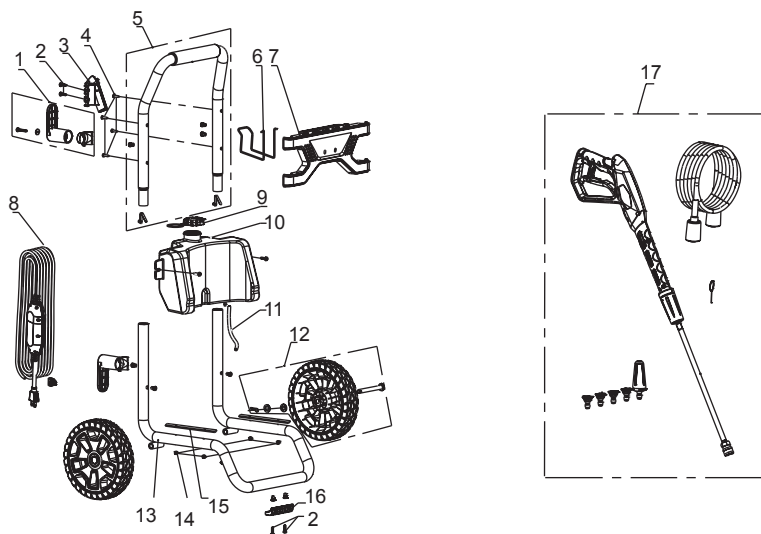

Item No.	Part No.	Description	Qty
1	C1101578-00	Cord retainer	2
2	322011635	Screw	6
3	341101936	Gun holder	1
4	322011628	Screw	10
5	C1106563-00	Upper handle assembly	1
6	333011936	Hose hook	1

7	C1106565-00	Front panel assembly	1
8	C6300318-00	Power cord	1
9	342011635	Cap	1
10	341031936	Soap tank	1
11	34900365	Suction hose	21
12	C1106566-00	Wheel assembly	2
13	C3203381-00	Lower handle	1
14	32222301A	Nut	4
15	342111936	Shock pad	2
16	341161635	Foot pad	1
17	C1106562-00	Accessory assembly	1
18	C4103519-00	Decorative cover	1
19	341081936	Left housing	1
20	311601936	Controller	1
21	341091936	Right housing	1
22	311221936	Switch box	1
23	341171936	Light cover	1
24	341013615	Loudspeaker cover	1
25	341403615	Air cover	1
26	C1102650-00	Water outlet connector	1
27	C1101112-00	Water inlet connector	1
28	361011936S	Motor	1
29	341411936	Water retaining cover	1
30	C1106561-00	Housing assembly	1