

**Non-Confidential Business Information  
(Non-CBI)**

**Certification Test Report**

**GHP Group, Inc.**

**Models:** PH1800WS, MWS-1800, WSL-1800-B,  
WSL-1800, GWS-1800-B, GWS-1800

**Wood-Fired Freestanding Room Heater**

**Prepared for:** GHP Group, Inc.  
6440 W Howard St  
Niles, IL 60714  
USA

**Prepared by:** OMNI-Test Laboratories, Inc.  
13327 NE Airport Way  
Portland, OR 97230  
(503) 643-3788

**Test Period:** January 29, 2020 – January 30, 2020

**Report Issued:** February 26, 2020

**Report Number:** 0418WS017E

*All data and information contained in this report are confidential and proprietary to GHP Group, Inc. Its significance is subject to the adequacy and representative character of the samples and to the comprehensiveness of the tests, examinations, or surveys made. The contents of this report cannot be copied or quoted, except in full, without specific, written authorization from GHP Group, Inc. and OMNI-Test Laboratories, Inc. No use of the OMNI-Test Laboratories, Inc. name, logo, or registered mark (O-TL) is permitted, except as expressly authorized by OMNI-Test Laboratories, Inc. in writing.*

*-Document Edition # 000 (02/26/2020)-*

## AUTHORIZED SIGNATORIES

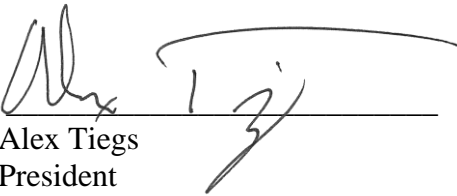
This report has been reviewed and approved by the following authorized signatories:

### Evaluator:



Bruce Davis  
Testing Manager

### Reviewer:



Alex Tiegs  
President

## TABLE OF CONTENTS

PREFACE.....	(3 pages)
1. SAMPLING PROCEDURES AND TEST RESULTS.....	4
Introduction.....	5
Individual Run summaries .....	6
<u>Summary Tables</u>	
Table 1 - Particulate Emissions Results.....	7
Table 2 - Particulate Emissions Results (First Hour).....	7
Table 3 – B415.1 Efficiency and CO Emissions .....	7
Table 4 - Test Facility Conditions .....	8
Table 5 – Kindling and Start-up Fuel Description Summary .....	8
Table 6 - Fuel Measurements and Cordwood Descriptions - Test.....	9
Table 7 - Dilution Tunnel Gas Measurements and Sampling Data .....	9
Table 10 - Test Configurations .....	10
2. PHOTOGRAPHS/APPLIANCE DESCRIPTION/DRAWINGS.....	11
Fuel Photographs .....	13
Appliance Description .....	17
Model Similarities.....	18
3. TEST DATA BY RUN.....	19
Run 1 .....	27
Run 2.....	46
Run 3.....	56
Run 4.....	64
4. QUALITY ASSURANCE/QUALITY CONTROL .....	73
Sample Analysis.....	75
Calibrations – ASTM E2515, ASTM E3053.....	83
Example Calculations .....	98
Appendix A Manufacturer’s Installation/Operation Instructions - Labels	
Appendix B Alt-125 E3053 Letter	

# **Section 1**

## **Sampling Procedures and Test Results**



## **INTRODUCTION**

GHP Group, Inc. retained *OMNI* to perform U.S. Environmental Protection Agency (EPA) certification testing on the PH1800WS Freestanding woodstove. The PH1800WS Freestanding wood stove is a Non-Catalytic-type room heater. The firebox is constructed of mild steel. Usable firebox volume was measured to be 1.78 cubic feet and the stove is vented through 6" flue collar located on the stove top.

Testing was performed at Nelke Consulting, altitude of the laboratory is 500 feet above sea level. The unit was received in good condition and logged in on 1/28/20, then assigned and labeled with *OMNI* ID #2402. *OMNI* representative Bruce Davis conducted the certification testing and completed all testing by January 30, 2020.

This report is organized in accordance with the EPA-recommended outline and is summarized in the Table of Contents immediately preceding this section. The results in this report are limited to the item submitted.

## **SAMPLING PROCEDURE**

The PH1800WS wood stove was tested in accordance with the U.S. EPA 40 CFR Part 60, Subpart AAA – Standards of Performance for New Residential Wood Heaters using ASTM E2515, EPA Alt-125, and ASTM E3053. Particulate emissions were measured using sampling trains consisting of two Teflon coated 47mm filters (front and back). See Appendix B for details on EPA Alt-125.

The model PH1800WS was tested for thermal efficiency and carbon monoxide (CO) emissions in accordance with CSA B415.1-10 using Cherry cordwood.

## **SUMMARY OF RESULTS**

The weighted average emissions of the three test runs included in the results indicate a particulate emission rate of 2.18 grams per hour. Particulate emissions used in the weighted average were sampled on only one of the high burn fuel loads, test 3 was conducted to generate a coal bed for test number 4. The PH1800WS results are within the emission limit of 2.5 g/h for affected facilities tested with cordwood, manufactured on or after May 15, 2020.

The proportionality results for all 3 test runs were acceptable. Quality check results for each test run are presented in Section 2 of this report.

## INDIVIDUAL RUN SUMMARIES

- Run 1 -** Test procedures followed to produce a high burn rate with a primary air setting of fully open. Observed burn rate was calculated at 4.84 kg/hr. Emissions results were calculated using particulate sampling from kindling, start-up fuel, and test fuel load combined (cold to hot). Burn rate, and efficiency were calculated using data from the test fuel load only (hot to hot). No sampling anomalies occurred; this test run was determined to be valid for inclusion in the weighted average.
- Run 2 -** Test procedures were followed to produce a low burn rate with a primary air setting of fully closed. Observed burn rate was calculated at 1.10 kg/hr. Emissions and efficiency results were calculated using a hot to hot burn cycle, a coal bed generated by the high burn conducted in test three was used. No sampling anomalies occurred; this test run was determined to be valid for inclusion in the weighted average.
- Run 3 -** Test procedures followed to produce a high burn rate with a primary air setting of fully open. Observed burn rate was calculated at 5.95 kg/hr. Burn rate, was calculated using data from the test fuel load only (hot to hot). No sampling occurred during this test; it was conducted to generate a coal bed for test number 4.
- Run 4 -** Test procedures were followed to produce a medium burn rate with a primary air setting of 0.1875" from full closed. Observed burn rate was calculated at 1.35 kg/hr. Emissions and efficiency results were calculated using a hot to hot burn cycle, a coal bed generated by the high burn procedure was used. No sampling anomalies occurred; this test run was determined to be valid for inclusion in the weighted average.

**Table 1 – Particulate Emissions**

<b>Run</b>	<b>Burn Rate</b> Calculated from a Hot to Hot burn cycle (kg/h dry)	<b>ASTM E2515 Emissions</b> (g/h)	<b>ASTM E3053 Weighting Factor</b> (%)	<b>ASTM E3053 Weighted Emissions</b> (g/h)
1	4.84	<sup>1</sup> 2.43	20	0.486
2	1.10	2.79	40	1.116
4	1.35	1.44	40	0.576
The sum of weighted particulate emission of 3 test runs, tests 1,2, and 4: 0.486 + 1.116 + 0.576 = <b>2.18</b> grams per hour.				

**Note:** <sup>1</sup> Based on a cold start including kindling and start-up fuel.

**Table 2 – Particulate Emissions (First Hour)**

<b>Run</b>	<b>ASTM E2515 Emissions – First Hour</b> (g/h)
1	2.80
2	12.12
4	2.99

**Table 3 – B415.1 Efficiency and CO Emissions**

<b>Run</b>	<b>Heat Output (BTU/h)</b>	<b>HHV Efficiency (%)</b>	<b>LHV Efficiency (%)</b>	<b>CO Emissions (g/MJ Output)</b>	<b>CO Emissions (g/kg Dry Fuel)</b>	<b>CO Emissions (g/min)</b>
1	62,789	68.8	73.7	1.42	18.59	1.572
2	14,208	70.6	75.7	6.40	87.50	1.599
4	17,349	70.2	75.3	4.71	63.91	1.435
Weighted average HHV efficiency of three test runs: $13.76 + 28.24 + 28.08 = \mathbf{70.1\%}$ .						
Average CO Emissions of three tests: $(1.572 + 1.599 + 1.435) / 3 = \mathbf{1.532 \text{ g/min}}$						

**Table 4 – Test Facility Conditions**

Run	Room Temperature (°F)		Barometric Pressure (Hg)		Air Velocity (ft/min)	
	Before	After	Before	After	Before	After
1	65	71	29.52	29.52	<50	<50
2	77	85	29.52	29.52	<50	<50
3	60	71	29.63	29.63	<50	<50
4	72	67	29.63	29.54	<50	<50

**Table 5 – Kindling and Start-up Fuel Description Summary  
Cherry Cordwood**

Run	Kindling Weight Wet Basis (lbs)	Start-up Fuel Weight Wet Basis (lbs)	Residual Start-up fuel weight (lbs)
1	3.60	5.40	1.8
3	3.60	5.40	1.9

Note: Test 3 was a high burn used to create a coal bed for test number 4, no particulate sampling occurred during this test.

**Table 6 – Fuel Measurement and Cordwood Description Summary – TEST  
Cherry Cordwood**

<b>Run</b>	<b>Test Fuel Wet Basis (lbs)</b>	<b>Firebox Volume (ft<sup>3</sup>)</b>	<b>Fuel Loading Density Wet Basis (lbs/ft<sup>3</sup>)</b>	<b>Test Fuel Dry Basis (lbs)</b>	<b>Test Fuel Consumed During Test Dry Basis (lbs)</b>	<b>Piece Length (in)</b>
1	18.0	1.78	10.1	14.63 + 7.76	18.8	<u>3@14.0</u> 2@16.0
2	20.80	1.78	11.7	16.9	16.9	<u>3@14.0</u> 2@16.0
3	18.0	1.78	10.1	14.49 + 7.67	18.5	<u>3@14.0</u> 2@16.0
4	21.0	1.78	11.8	17.3	17.3	<u>3@14.0</u> 2@16.0

**Table 7 – Dilution Tunnel Gas Measurements and Sampling Data Summary**

<b>Run</b>	<b>Length of Test (min)</b>	<b>Average Dilution Tunnel Gas Measurements</b>		
		<b>Velocity (ft/sec)</b>	<b>Flow Rate (dscf/min)</b>	<b>Temperature (°F)</b>
1	104	20.27	202.8	141
2	420	19.80	218.1	86
4	350	19.82	215.4	94

**Table 10 – Test Configurations**

<b>Run</b>	<b>Startup Procedures</b>	<b>Combustion Air</b>
1	<p><u>Fuel Loading:</u> Kindling and start-up fuel loaded together, a torch was used for 60 seconds to establish a fire. At 32 minutes placed fuel load into the firebox and closed the loading door. Loading required less than 1 minute to complete.</p> <p><u>Door:</u> For kindling and start-up fuel, loading door was closed by 2.25 minutes. Test fuel load; fuel loading door was closed by 1:00 minute.</p> <p><u>Primary Air:</u> Air control fully open for the entire test.</p> <p><u>Fan:</u> Turned to high 5 minutes after lighting fire, on high remainder of test.</p> <p><u>Bypass:</u> Open until 2:25 minutes, then fully closed.</p>	Fully open for entire test.
2	<p><u>Fuel Loading:</u> Test fuel loaded onto coal bed generated by test number 1 by 45 seconds.</p> <p><u>Door:</u> Closed by 45 seconds.</p> <p><u>Primary Air:</u> Fully open, then set to fully closed by 11.75 minutes.</p> <p><u>Fan:</u> Off for first 30 minute, then turned to high for remainder of test.</p> <p><u>Bypass:</u> Not used.</p>	Fully open for first 11.75 minutes, then set to full closed.
3	<p><u>Fuel Loading:</u> Kindling and start-up fuel loaded together, a torch was used for 60 seconds to establish a fire. At 30 minutes placed fuel load into the firebox and closed the loading door. Loading required 70 seconds to complete.</p> <p><u>Door:</u> For kindling and start-up fuel, loading door was closed by 2.30 minutes. Test fuel load; fuel loading door was closed by 75 seconds.</p> <p><u>Primary Air:</u> Air control fully open for the entire test.</p> <p><u>Fan:</u> Turned to high 5 minutes after lighting fire, on high remainder of test.</p> <p><u>Bypass:</u> Open until 2:30 minutes, then fully closed.</p>	Fully open for entire test.
4	<p><u>Fuel Loading:</u> Test fuel loaded onto coal bed generated by test number 3 by 60 seconds.</p> <p><u>Door:</u> Closed by 60 seconds.</p> <p><u>Primary Air:</u> Fully open, then set to 3/16" from fully closed by 11.50 minutes.</p> <p><u>Fan:</u> Off for first 30 minute, then turned to high for remainder of test.</p> <p><u>Bypass:</u> Not used.</p>	Fully open for first 11.5 minutes, then set to 3/16" from fully closed.

## **Section 2**

### **Photographs/Appliance Description/Drawings**

**GHP Group, Inc.**  
**Model PH1800WS**  
**Test Dates: January 29, 2020 – January 30, 2020**

Front Left View



Rear View



Front Right View



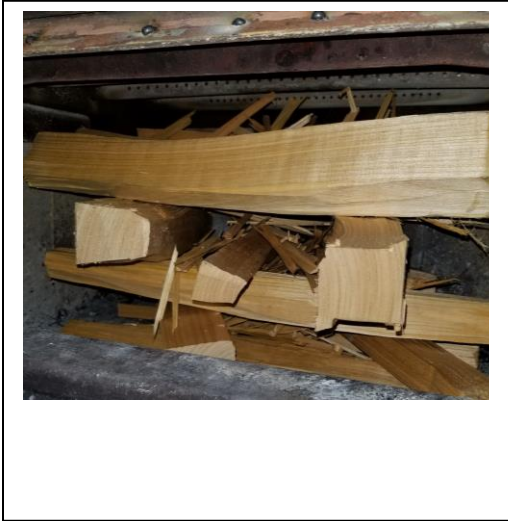


**GHP Group, Inc.  
Model N65**

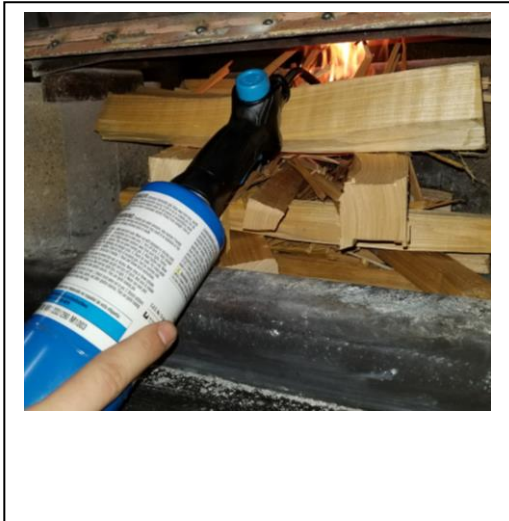
**Run 1 – Kindling and start-up fuel**



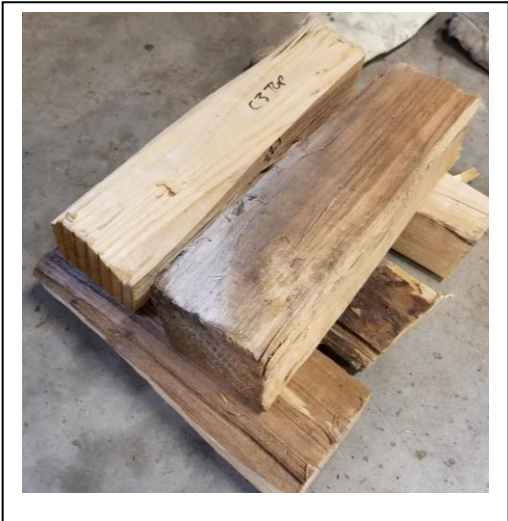
**Run 1 – Kindling and start-up fuel**



**Run 1 – Ignition of kindling**



**Run 1 – Fuel load**

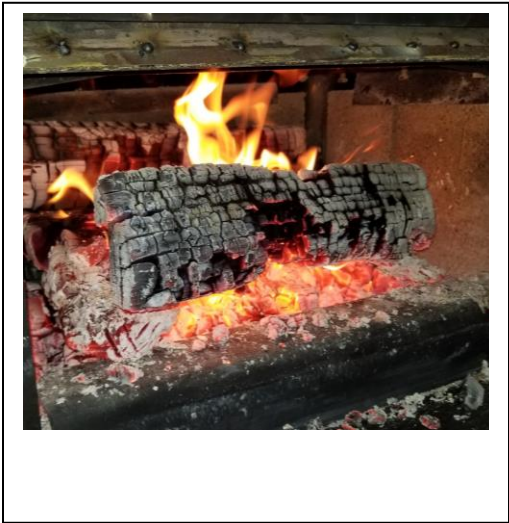


**GHP Group, Inc.  
Model N65**

**Run 1 – Test Fuel Load In Stove**



**Run 1 – Remaining Coal After Test**



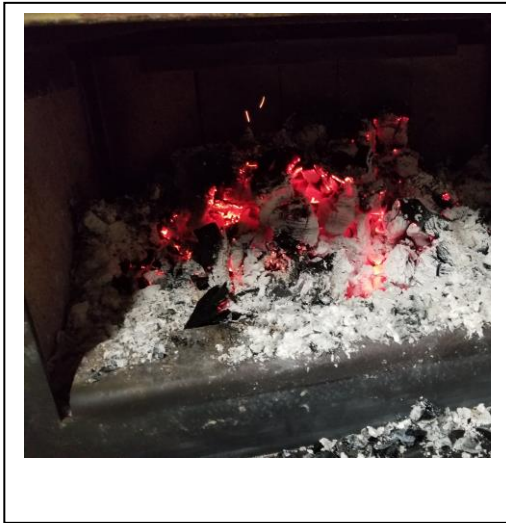
**Run 2 – Test Fuel Load**



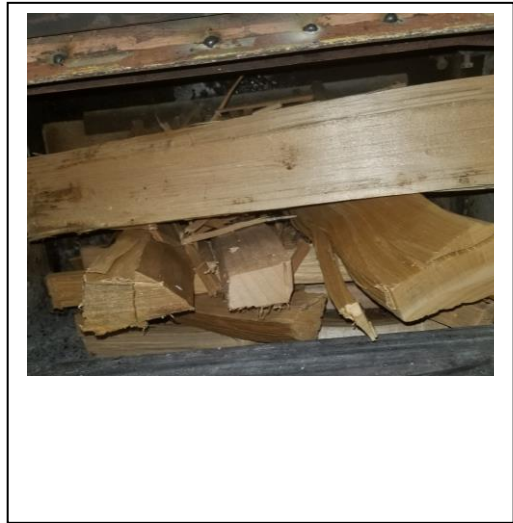
**Run 2 – Test Fuel Loaded into Stove**



**Run 2 – Remaining Coal After Test**



**Run 3 – Kindling and start-up fuel**



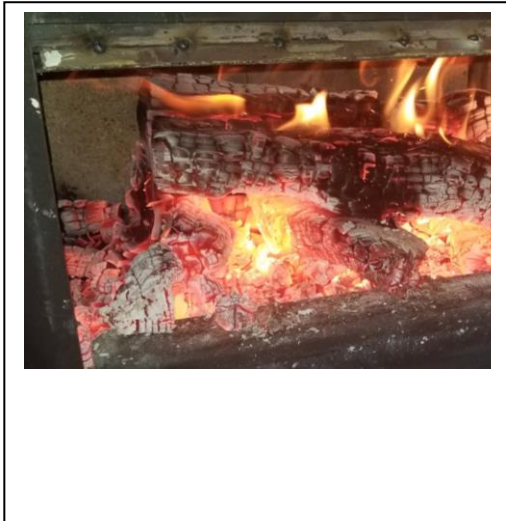
**Run 3 – Test Fuel Load**



**Run 3 – Test Fuel Loaded into Stove**



**Run 3 - Remaining Coal After Test**



**Run 4 – Test Fuel Load**



**Run 4 – Test Fuel Loaded into Stove**



**Run 4 – Remaining Coal After Test**





## WOOD HEATER DESCRIPTION

**Appliance Manufacturer:** GHP Group, Inc.

**Wood Stove Model:** PH1800WS

**Type:** Freestanding Wood Fired Room Heater

## WOOD HEATER INFORMATION

**Materials of Construction:** The unit is constructed primarily of mild steel. The firebox is lined with 1.25" thick refractory brick that measures 9.0 x 4-7/16" on the back, sides and hearth. The feed door has a 17.0 x 9.50 glass panel and 1" flat fiberglass gasket.

**Air Introduction System:** Primary air is controlled by a single slide plate located above the fuel loading door. Secondary air has no user control and enters the firebox through openings located on the bottom of the firebox.

**Combustion Control Mechanisms:** Combustion air control mechanism is a single slide plate that covers two 1.25" x 0.75" openings. A single 0.75" round opening is always open, regardless of air slide position.

**Combustor:** N/A

**Internal Baffles:** A two-piece vermiculite baffle is located above the secondary air tubes, a sliding vermiculite panel used as a flue gas bypass is mounted near the rear of the baffle.

**Other Features:** An optional blower is offered; the motor is 110 volts with a 200 CFM rating. See drawings for additional information.

**Flue Outlet:** The 6" diameter flue outlet is located at the rear of the top of the appliance.

## WOOD HEATER OPERATING INSTRUCTIONS

**Specific Written Instructions:** See Section 4 of this report. All markings and instruction materials were reviewed for content prior to printing.

## **MODEL SIMILARITIES**

GHP Group stove models PH1800WS, MWS-1800, WSL-1800-B, WSL-1800, GWS-1800-B, GWS-1800 are identical in all parts and operation. They are named differently for marketing reasons. No differences between models are identified in this report.

# **Section 3**

## **Test Data by Run**

## Conditioning Data

Manufacturer: GHP Group  
 Model: PH1800WS  
 Tracking No.: 2402  
 Project No.: 0418WS017E  
 Test Date: Nov, Dec 2019  
 Technician: Nelke Consulting  
 Operation Category: Various

Elapsed Time (hr)	Flue Gas Temp (° F)	
0	432.6	
1	420.0	
2	242.0	
3	187.0	
4	170.0	
5	156.0	
6	143.0	
7	128.0	
8	444.7	
9	451.0	
10	276.0	
11	207.0	
12	176.0	
13	150.0	
14	135.0	
15	121.0	
16	424.8	
17	458.0	
18	322.0	
19	241.0	
20	210.0	
21	182.0	
22	163.0	
23	154.0	
24	428.8	
25	336.0	

Elapsed Time (hr)	Flue Gas Temp (° F)	
26	351.3	
27	379.0	
28	285.0	
29	197.0	
30	167.0	
31	150.0	
32	135.0	
33	115.0	
34	108.0	
35	399.5	
36	405.0	
37	323.0	
38	221.0	
39	199.0	
40	173.0	
41	157.0	
42	145.0	
43	417.9	
44	439.0	
45	319.0	
46	219.0	
47	191.0	
48	176.0	
49	145.0	
50	132.0	

Technician Signature: 



## GHP Medium with By-Pass High Burn Procedure

### **Kindling:**

Kindling weight in total should be 3.0lbs ( $\pm 0.5$ bs) eight pieces in total of equal size, 14-16" in length. Making sure the weight doesn't exceed what's allowed per the standard.

### **Start-up Fuel:**

The start-up fuel consists of four pieces of equal size with a total weight of 5.0lbs ( $\pm 0.5$ lbs) and a length of 15-17".

### **Test Fuel:**

The test fuel consists of five pieces with a nominal length of 15". Follow the fuel sheet guideline for specific weights of the core and remainder loads.

### **Test fuel:**



### **Start-up Procedure:**

The start-up fuel is comprised of six layers as follows.

Bottom: Two kindling pieces East/West

2<sup>nd</sup>: Two kindling pieces North/South

3<sup>rd</sup>: Two kindling pieces East/West

4<sup>th</sup>: Two start-up pieces and one kindling piece North/South

5<sup>th</sup>: Two start-up pieces and one kindling piece East/West

Top: 0.6lbs – 0.5lbs pile of small kindling pieces in the middle as shown in the picture below, (4-5 Layers).

### **Kindling and Start-up:**



Open the by-pass and use a torch for 40 seconds to one minute to ignite the fuel, focusing the torch on the top middle portion of the load. Leave the door and by-pass open around 12 inches for one to two and a half minutes. The amount of

time for both the door and the by-pass are to be based on how involved the fuel is.

Set the fan control to the high position at five minutes.

The test load should be loaded at the bottom end of the allowable coal bed within 0.2lbs.

When loading, use the smaller of the test pieces to gently level the remaining fuel. Use the by-pass if needed. Place three of the smaller pieces cut at 14" are to be placed in a north/south direction on the bottom with gaps between the pieces. The remaining two pieces are on top in an east/west direction and not to come further then the front secondary tube. See test fuel picture for example. The door should be open  $\leq$  one minute. Once it's loaded, close the door and by-pass if used.

### High Burn Test Fuel:



End the test at the high end of the allowable remaining weight.

## **GHP Medium with By-Pass Medium and Low Procedure**

### **Test Fuel:**

Follow the guidelines of the cordwood standard (E3053-17) for correct moisture and weight ratios for the core and sub loads. There are five pieces in total. The nominal length is 15”.



### **Coal Bed:**

The coal bed will always result in running a high burn. There may be large pieces of fuel left after the high burn, as soon as the high burn has been complete, move the larger raw pieces toward the middle of the firebox stacked up for best combustion. Load the test fuel at the very low end of the coal bed within 0.2lbs. This allows more room to place the fuel.

### **Fuel Loading & Settings:**

Level the coal bed before you start sampling. If there happens to be any raw pieces left over, place them in the very rear to the right side of the unit. The Fan is turned on high after 30 minutes. Keep the door open no longer than two minutes.

Use the by-pass at the start of the test if needed. There should be minimal gaps between all fuel pieces. Three smaller pieces in a North/South direction and the remaining two larger pieces on top in an East/West direction (see test fuel picture above). Keep the primary control open until 15% of the fuel load has been consumed or if you see the combustion getting noticeably dirtier, set the control at the desired setting.

The setting for the low is closed to the stop.

The setting for the medium burn is 0.187" open from the low setting.

**Moving Fuel Load:**

It may be necessary to move the fuel load at some point during the medium and low burns. Keep an eye on weight drop and stack draft to determine when to move the fuel if needed.



Twin Ports Testing, Inc.  
 1301 North 3rd Street  
 Superior, WI 54880  
 p: 715-392-7114  
 p: 800-373-2562  
 f: 715-392-7163  
 www.twinportstesting.com

## Analytical Test Report

**Report No:** USR:W219-0497-01  
**Issue No:** 1

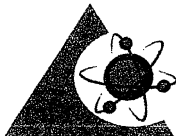
**Client:** Nelke Consulting  
 30522 SE Leavenworth Ct  
 Eagle Creek, OR 97022  
**Attention:** Ben Nelke  
**PO No:** Prepaid

**Signed:** *Stephen Sundeen*  
 Stephen Sundeen  
 Chemistry Laboratory Manager  
**Date of Issue:** 7/2/2019  
THIS DOCUMENT SHALL NOT BE REPRODUCED EXCEPT IN FULL

**Sample Details**  
**Sample Log No:** W219-0497-01      **Sample Date:**  
**Sample Designation:** Sawdust      **Sample Time:**  
**Sample Recognized As:** Biomass      **Arrival Date:** 6/11/2019

	METHOD	UNITS	MOISTURE	
			FREE	AS RECEIVED
Moisture Total	ASTM E871	wt. %		10.63
Ash	ASTM D1102	wt. %	0.40	0.36
Volatile Matter	ASTM D3175	wt. %	82.82	74.02
Fixed Carbon by Difference	ASTM D3172	wt. %	16.78	15.00
Sulfur	ASTM D4239	wt. %	0.086	0.077
SO <sub>2</sub>	Calculated	lb/mmbtu		0.206
Net Cal. Value at Const. Pressure	ISO 1928	GJ/tonne	18.03	15.86
Gross Cal. Value at Const. Vol.	ASTM E711	Btu/lb	8316	7432
Carbon	ASTM D5373	wt. %	48.68	43.50
Hydrogen*	ASTM D5373	wt. %	6.01	5.37
Nitrogen	ASTM D5373	wt. %	< 0.20	< 0.18
Oxygen*	ASTM D3176	wt. %	> 44.63	> 39.89
*Note: As received values do not include hydrogen and oxygen in the total moisture.				
Chlorine	ASTM D6721	mg/kg		
Fluorine	ASTM D3761	mg/kg		
Mercury	ASTM D6722	mg/kg		
Density	ASTM E873	ka/m <sup>3</sup>		611

**Comments:**



PJLA Testing  
 Accreditation #60243

Results issued on this report only reflect the analysis of the sample submitted. Our reports and letters are for the exclusive and confidential use of our clients and may not be reproduced, except in their entirety, without the written approval of Twin Ports Testing. Twin Ports Testing Laboratory is accredited to the ISO/IEC 17025:2005 standard by PJLA.

# **Run 1**

**High Burn 1-minute data**


**Emissions Results (Cold to Hot Cycle)**

### Wood Heater Test Data

Run: 1

Manufacturer: GHP Group  
 Model: PH1800WS  
 Tracking No.: 2402  
 Project No.: 0418WS017E  
 Test Date: 29-Jan-20  
 Beginning Clock Time: 10:20  
 Total Sampling Time: 104 min  
 Recording Interval: 1 min  
 Background Sample Volume: \_\_\_\_\_ cubic feet  
 Meter Box Y Factor: 0.988 (1) 0.985 (2) \_\_\_\_\_ (Amb)  
 Barometric Pressure: Begin Middle End Average  
29.52 29.52 29.52 0  
 OMNI Equipment Numbers: \_\_\_\_\_

PM Control Modules: 371, 372  
 Dilution Tunnel MW (dry): 29.00 lb/lb-mole  
 Dilution Tunnel MW (wet): 28.78 lb/lb-mole  
 Dilution Tunnel H2O: 2.00 percent  
 Dilution Tunnel Static: -0.260 "H2O  
 Tunnel Area: 0.19635 ft<sup>2</sup>  
 Pitot Tube Cp: 0.99  
 Avg. Tunnel Velocity: 20.27 ft/sec.  
 Initial Tunnel Flow: 233.1 scfm  
 Average Tunnel Flow: 202.8 scfm  
 Post-Test Leak Check (1): 0.000 cfm @ 8 in. Hg  
 Post-Test Leak Check (2): 0.000 cfm @ 8 in. Hg  
 Average Test Piece Fuel Moisture: 23.11 Dry Basis %

Technician Signature: 

Velocity Traverse Data									
	Pt.1	Pt.2	Pt.3	Pt.4	Pt.5	Pt.6	Pt.7	Pt.8	Center
Initial dP	0.100	0.098	0.106	0.090	0.080	0.098	0.100	0.084	0.104
Temp:	69	69	69	69	69	69	69	69	69
	V <sub>strav</sub> 20.63 ft/sec				V <sub>scnt</sub> 21.54 ft/sec				F <sub>p</sub> 0.958

Elapsed Time (min)	Particulate Sampling Data												Fuel Weight (lb)		Temperature Data (°F)										Stack Gas Data						
	Gas Meter 1 (ft <sup>3</sup> )	Gas Meter 2 (ft <sup>3</sup> )	Sample Rate 1 (cfm)	Sample Rate 2 (cfm)	Orifice dH 1 ("H <sub>2</sub> O)	Meter 1 Temp (°F)	Meter 1 Vacuum ("Hg)	Orifice dH 2 ("H <sub>2</sub> O)	Meter 2 Temp (°F)	Meter 2 Vacuum ("Hg)	Dilution Tunnel (°F)	Dilution Tunnel Center dP	Pro. Rate 1	Pro. Rate 2	Scale Reading	Weight Change	Firebox Top	Firebox Bottom	Firebox Back	Firebox Left	Firebox Right	Avg. Stove Surface	Stack	Filter 1	Dryer Exit 1	Filter 2	Dryer Exit 2	Ambient	Draft ("H <sub>2</sub> O)	CO <sub>2</sub> (%)	CO (%)
0	0.000	0.000			2.50	67	-2.37	2.05	66	-1	69	0.100			8.9		62	59	60	61	60	60	66	84	63	83	59	65	0.000	0.05	0
1	0.159	0.168	0.16	0.17	2.19	67	-3.72	1.76	66	-1.4	91	0.100	88	89	8.9	0	64	59	60	61	60	61	135	83	64	82	59	65	0.001	0.7	0.01
2	0.319	0.338	0.16	0.17	2.15	67	-3.42	1.70	66	-1.7	98	0.100	89	90	8.8	-0.1	69	59	61	61	61	62	183	83	65	82	59	66	0.006	1.69	0.09
3	0.482	0.512	0.16	0.17	2.26	67	-4.12	1.85	66	-1.8	92	0.100	90	92	8.6	-0.2	110	59	65	61	61	71	269	83	66	82	60	66	0.016	5.13	0.25
4	0.645	0.686	0.16	0.17	2.25	67	-3.9	1.78	66	-2	98	0.100	91	92	8.4	-0.2	177	59	72	62	63	87	338	83	66	82	60	66	0.031	8.87	0.2
5	0.808	0.858	0.16	0.17	2.27	67	-3.98	1.76	66	-1.7	106	0.090	96	97	8.1	-0.3	244	59	79	63	65	102	404	83	67	83	60	66	0.045	9.53	0.19
6	0.971	1.028	0.16	0.17	2.26	67	-4.23	1.76	66	-1.9	110	0.090	97	96	7.8	-0.28	309	59	77	65	68	116	446	84	68	83	60	66	0.056	10.91	0.33
7	1.134	1.199	0.16	0.17	2.25	67	-4.24	1.75	66	-1.7	115	0.090	97	97	7.6	-0.22	360	59	81	67	72	128	467	84	68	83	60	66	0.060	10.42	0.31
8	1.296	1.369	0.16	0.17	2.24	67	-3.99	1.78	66	-1.7	116	0.090	97	97	7.3	-0.3	407	60	86	70	77	140	484	85	69	84	61	66	0.064	11.15	0.3
9	1.458	1.541	0.16	0.17	2.24	67	-4.16	1.77	66	-1.8	117	0.090	97	98	7.1	-0.2	436	61	95	74	83	150	481	85	69	84	61	66	0.065	9.94	0.24
10	1.620	1.712	0.16	0.17	2.26	67	-4.02	1.76	66	-2	118	0.090	97	97	6.8	-0.3	457	63	100	78	90	158	488	85	70	84	61	66	0.066	10.07	0.19
11	1.783	1.883	0.16	0.17	2.24	68	-4.02	1.75	66	-2	121	0.090	97	98	6.5	-0.3	474	66	102	83	96	164	493	86	70	84	61	66	0.065	8.41	0.29
12	1.946	2.053	0.16	0.17	2.24	68	-3.92	1.74	66	-2.1	123	0.090	98	97	6.4	-0.1	488	69	102	88	103	170	498	86	71	84	62	66	0.066	9.29	0.28
13	2.108	2.223	0.16	0.17	2.23	68	-3.97	1.74	66	-1.8	127	0.090	97	98	6.1	-0.3	503	73	105	93	110	177	517	86	71	84	62	66	0.067	9.93	0.26
14	2.271	2.393	0.16	0.17	2.27	68	-4.04	1.76	66	-2.1	129	0.090	98	98	5.8	-0.3	514	77	107	98	117	183	532	86	71	85	62	67	0.068	11.85	0.23
15	2.435	2.564	0.16	0.17	2.27	68	-4.11	1.74	67	-1.9	131	0.090	99	98	5.6	-0.22	526	81	114	104	126	190	543	87	71	85	62	67	0.069	11.79	0.23
16	2.598	2.734	0.16	0.17	2.28	68	-4.15	1.74	67	-2	135	0.090	99	98	5.3	-0.28	543	87	114	111	135	198	562	87	72	85	62	67	0.071	12.93	0.25
17	2.762	2.903	0.16	0.17	2.26	68	-4.13	1.71	67	-2.1	137	0.090	99	98	5.0	-0.34	562	92	118	118	144	207	576	87	72	86	62	67	0.072	12.85	0.21
18	2.924	3.072	0.16	0.17	2.24	68	-4.43	1.70	67	-2.1	141	0.090	98	98	4.7	-0.28	581	98	122	126	152	216	590	87	72	86	63	67	0.074	13.39	0.22
19	3.088	3.243	0.16	0.17	2.29	68	-4.22	1.79	67	-2	143	0.090	100	99	4.4	-0.28	608	104	129	134	160	227	607	88	72	86	63	67	0.075	14.15	0.23
20	3.251	3.415	0.16	0.17	2.25	68	-4.23	1.78	67	-2.2	144	0.090	99	100	4.1	-0.3	627	110	139	144	169	238	611	88	73	86	63	67	0.076	13.58	0.21
21	3.414	3.587	0.16	0.17	2.26	68	-4.16	1.77	67	-2.2	143	0.090	99	100	3.8	-0.3	642	117	145	154	179	247	607	89	73	86	63	67	0.077	12.99	0.16
22	3.577	3.759	0.16	0.17	2.26	68	-4.25	1.76	67	-2.2	142	0.090	99	100	3.6	-0.2	650	124	153	165	190	256	602	89	73	86	63	68	0.076	12.04	0.06
23	3.740	3.929	0.16	0.17	2.22	68	-4.18	1.75	67	-2.4	143	0.080	105	105	3.4	-0.2	654	132	160	177	199	264	602	88	73	86	63	68	0.076	12.01	0.07
24	3.902	4.101	0.16	0.17	2.25	69	-4.55	1.78	67	-2.2	141	0.090	98	100	3.1	-0.3	657	139	168	188	211	273	598	88	73	86	63	67	0.076	12.3	0.08
25	4.065	4.274	0.16	0.17	2.26	69	-4.61	1.77	67	-2.3	140	0.090	99	100	3.0	-0.1	653	147	174	200	224	280	585	88	73	85	63	68	0.075	11	0.05
26	4.228	4.446	0.16	0.17	2.24	69	-4.52	1.78	67	-2.2	138	0.090	99	99	2.7	-0.3	644	156	183	211	238	286	576	88	74	85	64	67	0.074	10.47	0.05
27	4.390	4.618	0.16	0.17	2.23	69	-4.35	1.77	67	-2.5	136	0.090	98	99	2.6	-0.1	636	165	190	221	251	293	568	88	72	85	64	68	0.073	10.01	0.04
28	4.553	4.790	0.16	0.17	2.22	69	-4.46	1.79	67	-2.5	135	0.090	98	99	2.4	-0.2	627	174	195	233	265	299	561	87	68	85	64	68	0.072	9.74	0.03
29	4.714	4.963	0.16	0.17	2.26	69	-4.58	1.77	67	-2.4	133	0.090	97	100	2.3	-0.1	618	182	202	243	277	304	554	87	67	85	64	68	0.071	9.44	0.03
30	4.878	5.135	0.16	0.17	2.28	69	-4.53	1.77	67	-2.2	132	0.090	99	99	2.1	-0.2	610	191	203	254	289	309	548	87	67	85	64	68	0.071	9.25	0.03
31	5.042	5.307	0.16	0.17	2.25	69	-4.36	1.79	68	-2.2	132	0.090	99	99	2.0	-0.1	605	201	209	264	300	316	544	87	67	84	64	68	0.070	9.16	0.03
32	5.205	5.479	0.16	0.17	2.23	69	-4.74	1.76	68	-2.3	177	0.090	102	102	18.0	16	575	212	217	273	315	318	448	88	67	85	65	67	0.065	5.62	0.06
33	5.365	5.647	0.16	0.17	2.27	69	-7.76	1.83	68	-6.3	142	0.090	97	97	17.3	-0.7	557	224	217	282	322	320	510	87	67	85	65	68	0.065	6.4	0.75
34	5.514	5.807	0.15	0.16	1.53	70	-13.56	1.28	68	-12.6	152	0.090	91	93	17.0	-0.3	598	235	212	292	331	334	614	86	67	84	65	68	0.068	12.95	0.56
35	5.642	5.942	0.13	0.14	1.49	70	-13.77	1.00	68	-13.5	154	0.080	83	84	16.7	-0.3	642	247	208	300	338	347	640	85	68	83	66	69	0.073	13.43	0.26
36	5.829	6.062	0.19	0.12	2.37	70	-5.15	0.87	68	-14	152	0.080	121	74	16.4	-0.3	666	258	201	308	345	356	640	85	68	83	66	68	0.080	12.27	0.34



### Wood Heater Test Data

Run: 1

Manufacturer: GHP Group  
 Model: PH1800WS  
 Tracking No.: 2402  
 Project No.: 0418WS017E  
 Test Date: 29-Jan-20  
 Beginning Clock Time: 10:20  
 Total Sampling Time: 104 min  
 Recording Interval: 1 min  
 Background Sample Volume: \_\_\_\_\_ cubic feet  
 Meter Box Y Factor: 0.988 (1) 0.985 (2) \_\_\_\_\_ (Amb)  
 Barometric Pressure: Begin Middle End Average  
29.52 29.52 29.52 0  
 OMNI Equipment Numbers: \_\_\_\_\_

PM Control Modules: 371, 372  
 Dilution Tunnel MW(dry): 29.00 lb/lb-mole  
 Dilution Tunnel MW(wet): 28.78 lb/lb-mole  
 Dilution Tunnel H2O: 2.00 percent  
 Dilution Tunnel Static: -0.260 "H2O  
 Tunnel Area: 0.19635 ft<sup>2</sup>  
 Pitot Tube Cp: 0.99  
 Avg. Tunnel Velocity: 20.27 ft/sec.  
 Initial Tunnel Flow: 233.1 scfm  
 Average Tunnel Flow: 202.8 scfm  
 Post-Test Leak Check (1): 0.000 cfm @ 8 in. Hg  
 Post-Test Leak Check (2): 0.000 cfm @ 8 in. Hg  
 Average Test Piece Fuel Moisture: 23.11 Dry Basis %

Technician Signature: 

Velocity Traverse Data									
	Pt.1	Pt.2	Pt.3	Pt.4	Pt.5	Pt.6	Pt.7	Pt.8	Center
Initial dP	0.100	0.098	0.106	0.090	0.080	0.098	0.100	0.084	0.104
Temp:	69	69	69	69	69	69	69	69	69
	V <sub>strav</sub> 20.63 ft/sec				V <sub>scnt</sub> 21.54 ft/sec			F <sub>p</sub> 0.958	

Elapsed Time (min)	Particulate Sampling Data												Fuel Weight (lb)		Temperature Data (°F)										Stack Gas Data						
	Gas Meter 1 (ft <sup>3</sup> )	Gas Meter 2 (ft <sup>3</sup> )	Sample Rate 1 (cfm)	Sample Rate 2 (cfm)	Orifice dH 1 ("H <sub>2</sub> O)	Meter 1 Temp (°F)	Meter 1 Vacuum ("Hg)	Orifice dH 2 ("H <sub>2</sub> O)	Meter 2 Temp (°F)	Meter 2 Vacuum ("Hg)	Dilution Tunnel (°F)	Dilution Tunnel Center dP	Pro. Rate 1	Pro. Rate 2	Scale Reading	Weight Change	Firebox Top	Firebox Bottom	Firebox Back	Firebox Left	Firebox Right	Avg. Stove Surface	Stack	Filter 1	Dryer Exit 1	Filter 2	Dryer Exit 2	Ambient	Draft ("H <sub>2</sub> O)	CO <sub>2</sub> (%)	CO (%)
37	5.998	6.233	0.17	0.17	1.97	70	-4.31	1.79	68	-2.1	152	0.080	109	106	16.1	-0.3	684	269	194	313	351	362	636	87	68	83	67	68	0.080	11.78	0.31
38	6.162	6.407	0.16	0.17	2.33	70	-4.66	1.81	68	-2	152	0.080	106	108	15.8	-0.3	689	278	186	317	355	365	632	88	68	84	67	69	0.079	11.21	0.34
39	6.328	6.580	0.17	0.17	2.36	70	-4.57	1.79	68	-2.2	151	0.090	101	101	15.5	-0.28	698	288	182	321	362	370	634	88	68	85	67	69	0.078	11.1	0.35
40	6.492	6.752	0.16	0.17	2.26	70	-4.31	1.77	68	-2.2	153	0.090	100	101	15.3	-0.22	702	296	180	323	364	373	641	88	68	85	68	68	0.079	11.55	0.35
41	6.655	6.925	0.16	0.17	2.23	70	-4.64	1.77	68	-2.3	157	0.080	106	108	15.0	-0.32	711	304	177	325	369	377	659	88	69	85	68	69	0.079	12.08	0.36
42	6.817	7.098	0.16	0.17	2.24	70	-4.45	1.81	68	-2.4	158	0.090	99	102	14.7	-0.28	724	312	175	328	373	382	675	88	69	85	68	69	0.081	14.14	0.25
43	6.979	7.271	0.16	0.17	2.27	71	-4.89	1.80	69	-2.4	160	0.080	105	108	14.3	-0.36	736	319	174	329	378	387	681	88	69	85	69	69	0.082	13.89	0.23
44	7.144	7.444	0.17	0.17	2.28	71	-4.59	1.80	69	-2.4	160	0.080	107	108	14.1	-0.28	744	326	174	330	381	391	683	88	69	85	69	68	0.083	13.7	0.22
45	7.307	7.620	0.16	0.18	2.25	71	-4.63	1.84	69	-2.3	159	0.080	106	109	13.7	-0.36	751	333	175	332	386	395	681	88	70	85	69	69	0.083	13.41	0.2
46	7.470	7.794	0.16	0.17	2.26	71	-4.78	1.81	69	-2.2	158	0.080	106	108	13.4	-0.3	755	339	174	333	391	398	680	88	70	85	70	69	0.083	13.23	0.21
47	7.634	7.968	0.16	0.17	2.29	71	-4.62	1.78	69	-2.1	160	0.080	107	108	13.2	-0.22	755	344	174	335	394	400	680	89	70	85	70	69	0.082	13.22	0.2
48	7.799	8.140	0.17	0.17	2.28	71	-4.58	1.78	69	-2.3	160	0.090	101	101	12.9	-0.28	757	350	174	337	400	404	677	88	70	85	70	69	0.082	13.06	0.19
49	7.962	8.314	0.16	0.17	2.27	71	-5	1.80	69	-2.1	159	0.080	106	108	12.6	-0.3	755	356	174	339	405	406	673	88	71	85	71	69	0.082	12.88	0.18
50	8.126	8.489	0.16	0.18	2.29	71	-5.01	1.82	69	-2.3	156	0.080	106	109	12.3	-0.3	753	361	176	340	410	408	672	88	71	85	71	69	0.082	12.79	0.18
51	8.290	8.663	0.16	0.17	2.25	72	-4.96	1.81	69	-2.3	158	0.080	106	108	12.0	-0.26	749	366	177	343	416	410	666	87	71	85	72	69	0.082	12.64	0.18
52	8.453	8.838	0.16	0.17	2.28	72	-5.04	1.82	69	-2.1	156	0.090	99	102	11.8	-0.24	748	370	178	345	423	413	663	87	71	85	72	69	0.081	12.36	0.17
53	8.618	9.012	0.17	0.17	2.29	72	-5.01	1.83	70	-2.3	156	0.090	101	102	11.5	-0.3	745	375	178	348	428	415	657	87	72	85	72	68	0.081	12.24	0.17
54	8.783	9.188	0.16	0.18	2.27	72	-5	1.82	70	-2	155	0.080	107	109	11.2	-0.28	741	379	178	349	432	416	655	87	72	85	73	69	0.080	12.14	0.16
55	8.947	9.363	0.16	0.17	2.30	72	-4.97	1.82	70	-2	154	0.080	106	108	11.0	-0.22	740	384	180	352	439	419	652	87	72	85	73	70	0.080	12.03	0.14
56	9.113	9.537	0.17	0.17	2.33	72	-4.55	1.81	70	-2	152	0.090	101	101	10.7	-0.3	736	388	181	354	444	421	649	87	72	86	73	69	0.080	11.89	0.14
57	9.280	9.712	0.17	0.17	2.33	72	-4.94	1.82	70	-2.3	153	0.090	102	102	10.5	-0.2	733	392	182	357	449	423	646	87	73	86	73	70	0.080	11.81	0.14
58	9.446	9.886	0.17	0.17	2.31	72	-4.64	1.81	70	-2.1	153	0.090	101	101	10.3	-0.2	730	396	184	359	452	424	645	87	73	86	74	70	0.079	11.88	0.13
59	9.610	10.061	0.16	0.18	2.27	73	-4.64	1.81	70	-2.2	152	0.090	100	102	10.0	-0.3	730	400	186	363	457	427	645	87	73	86	74	70	0.079	11.91	0.11
60	9.775	10.235	0.17	0.17	2.31	73	-4.94	1.82	70	-2.1	152	0.090	100	101	9.8	-0.2	726	404	187	365	461	429	640	87	73	86	74	69	0.079	11.75	0.11
61	9.941	10.409	0.17	0.17	2.33	73	-4.83	1.79	70	-2.1	151	0.090	101	101	9.5	-0.3	724	408	188	366	465	430	638	87	74	86	75	70	0.079	11.65	0.11
62	10.110	10.584	0.17	0.17	2.36	73	-4.88	1.81	70	-2.3	151	0.080	109	108	9.3	-0.2	721	412	190	369	469	432	637	84	74	86	75	70	0.079	11.6	0.11
63	10.276	10.758	0.17	0.17	2.29	73	-4.74	1.81	71	-2.1	151	0.080	107	107	9.1	-0.2	717	416	193	370	472	434	636	86	74	86	75	70	0.078	11.64	0.11
64	10.441	10.933	0.17	0.18	2.29	73	-4.88	1.79	71	-2.2	149	0.090	100	101	8.8	-0.3	718	420	196	373	475	436	634	87	74	86	76	70	0.078	11.63	0.12
65	10.606	11.106	0.16	0.17	2.29	73	-4.87	1.79	71	-2.2	150	0.090	100	100	8.6	-0.2	717	424	199	376	478	439	634	87	75	86	76	70	0.078	11.6	0.12
66	10.771	11.280	0.17	0.17	2.32	73	-4.82	1.80	71	-2.2	150	0.080	106	107	8.3	-0.3	717	428	199	377	481	440	634	87	75	86	76	71	0.078	11.65	0.11
67	10.937	11.454	0.17	0.17	2.30	74	-4.63	1.81	71	-2.2	150	0.090	100	101	8.1	-0.2	716	431	202	379	485	443	636	87	75	86	77	70	0.078	11.78	0.11
68	11.101	11.628	0.16	0.17	2.30	74	-4.89	1.80	71	-2.3	151	0.080	105	107	7.9	-0.2	717	435	206	383	487	446	633	87	75	86	77	71	0.078	11.66	0.11
69	11.267	11.803	0.17	0.18	2.30	74	-4.81	1.79	71	-2	150	0.090	100	101	7.7	-0.22	717	439	206	384	489	447	631	87	76	86	77	71	0.078	11.56	0.12
70	11.433	11.977	0.17	0.17	2.31	74	-4.47	1.81	71	-2.2	148	0.090	100	101	7.5	-0.18	717	442	211	386	492	450	631	87	76	86	78	71	0.078	11.54	0.12
71	11.600	12.152	0.17	0.17	2.33	74	-4.51	1.80	71	-2	149	0.090	101	101	7.2	-0.3	717	446	212	390	495	452	631	87	76	86	78	70	0.077	11.56	0.12
72	11.766	12.325	0.17	0.17	2.30	74	-4.69	1.79	71	-2.2	149	0.090	100	100	7.0	-0.2	718	450	217	392	498	455	629	87	76	86	78	71	0.077	11.54	0.12
73	11.932	12.499	0.17	0.17	2.30	74	-4.67	1.79	72	-2.1	149	0.090	100	101	6.8	-0.2	718	453	224	395	501	458	627	87	76	86	78	71	0.077	11.46	0.12

### Wood Heater Test Data


Run: 1

Manufacturer: GHP Group  
 Model: PH1800WS  
 Tracking No.: 2402  
 Project No.: 0418WS017E  
 Test Date: 29-Jan-20  
 Beginning Clock Time: 10:20  
 Meter Box Y Factor: 0.988 (1) 0.985 (2) \_\_\_\_\_ (Amb)  
 Barometric Pressure: Begin Middle End Average  
29.52 29.52 29.52 0  
 OMNI Equipment Numbers: \_\_\_\_\_

Total Sampling Time: 104 min  
 Recording Interval: 1 min

Background Sample Volume: \_\_\_\_\_ cubic feet

PM Control Modules: 371, 372  
 Dilution Tunnel MW(dry): 29.00 lb/lb-mole  
 Dilution Tunnel MW(wet): 28.78 lb/lb-mole  
 Dilution Tunnel H2O: 2.00 percent  
 Dilution Tunnel Static: -0.260 "H2O  
 Tunnel Area: 0.19635 ft<sup>2</sup>  
 Pitot Tube Cp: 0.99  
 Avg. Tunnel Velocity: 20.27 ft/sec.  
 Initial Tunnel Flow: 233.1 scfm  
 Average Tunnel Flow: 202.8 scfm  
 Post-Test Leak Check (1): 0.000 cfm @ 8 in. Hg  
 Post-Test Leak Check (2): 0.000 cfm @ 8 in. Hg  
 Average Test Piece Fuel Moisture: 23.11 Dry Basis %

Technician Signature: 

Velocity Traverse Data									
	Pt.1	Pt.2	Pt.3	Pt.4	Pt.5	Pt.6	Pt.7	Pt.8	Center
Initial dP	0.100	0.098	0.106	0.090	0.080	0.098	0.100	0.084	0.104
Temp:	69	69	69	69	69	69	69	69	69
	V <sub>strav</sub> <u>20.63</u> ft/sec				V <sub>scnt</sub> <u>21.54</u> ft/sec				F <sub>p</sub> <u>0.958</u>

Elapsed Time (min)	Particulate Sampling Data												Fuel Weight (lb)		Temperature Data (°F)										Stack Gas Data						
	Gas Meter 1 (ft <sup>3</sup> )	Gas Meter 2 (ft <sup>3</sup> )	Sample Rate 1 (cfm)	Sample Rate 2 (cfm)	Orifice dH 1 ("H <sub>2</sub> O)	Meter 1 Temp (°F)	Meter 1 Vacuum ("Hg)	Orifice dH 2 ("H <sub>2</sub> O)	Meter 2 Temp (°F)	Meter 2 Vacuum ("Hg)	Dilution Tunnel (°F)	Dilution Tunnel Center dP	Pro. Rate 1	Pro. Rate 2	Scale Reading	Weight Change	Firebox Top	Firebox Bottom	Firebox Back	Firebox Left	Firebox Right	Avg. Stove Surface	Stack	Filter 1	Dryer Exit 1	Filter 2	Dryer Exit 2	Ambient	Draft ("H <sub>2</sub> O)	CO <sub>2</sub> (%)	CO (%)
74	12.097	12.673	0.16	0.17	2.28	74	-4.83	1.79	72	-2.1	148	0.090	100	101	6.6	-0.2	717	457	223	397	504	460	625	87	75	86	77	71	0.077	11.46	0.11
75	12.262	12.846	0.17	0.17	2.26	74	-4.56	1.78	72	-2.1	147	0.090	100	100	6.4	-0.2	714	461	228	399	505	461	623	87	74	86	76	71	0.077	11.36	0.11
76	12.427	13.019	0.16	0.17	2.29	75	-4.5	1.77	72	-2.1	147	0.090	99	100	6.2	-0.2	713	465	233	402	508	464	624	87	73	86	75	71	0.077	11.32	0.08
77	12.592	13.192	0.17	0.17	2.30	75	-4.65	1.77	72	-2.1	147	0.090	99	100	6.0	-0.2	712	469	235	404	513	467	621	87	72	86	74	71	0.077	11.43	0.07
78	12.758	13.365	0.17	0.17	2.30	75	-4.89	1.77	72	-2.1	146	0.090	100	100	5.8	-0.2	712	473	242	406	515	470	620	87	72	86	73	71	0.077	11.36	0.06
79	12.924	13.537	0.17	0.17	2.32	75	-4.88	1.77	72	-2.2	146	0.090	100	99	5.6	-0.2	708	477	246	407	517	471	618	87	71	86	73	72	0.076	11.26	0.06
80	13.091	13.710	0.17	0.17	2.31	75	-4.67	1.77	72	-2.3	146	0.090	101	100	5.5	-0.14	707	481	250	410	520	474	616	87	70	86	72	71	0.076	11.15	0.05
81	13.257	13.883	0.17	0.17	2.31	75	-4.64	1.76	72	-2.2	145	0.090	100	100	5.2	-0.26	705	485	252	412	522	475	613	87	69	86	71	71	0.076	11	0.05
82	13.423	14.055	0.17	0.17	2.31	75	-4.78	1.77	72	-2.3	144	0.090	100	99	5.1	-0.12	702	490	257	416	524	478	610	87	68	86	71	73	0.076	10.89	0.05
83	13.589	14.227	0.17	0.17	2.32	75	-4.88	1.76	73	-2.1	144	0.080	106	105	4.9	-0.18	697	494	261	420	529	480	607	87	68	86	70	72	0.075	10.79	0.05
84	13.756	14.400	0.17	0.17	2.33	75	-4.69	1.76	73	-2.2	142	0.090	100	99	4.7	-0.2	693	498	266	422	530	482	601	87	67	86	69	72	0.075	10.66	0.05
85	13.922	14.572	0.17	0.17	2.31	76	-4.47	1.75	73	-2.1	142	0.090	99	99	4.5	-0.2	690	502	271	425	533	484	598	87	67	86	69	72	0.075	10.54	0.05
86	14.089	14.745	0.17	0.17	2.31	76	-4.86	1.75	73	-2.3	143	0.090	100	99	4.4	-0.1	685	506	276	429	533	486	595	87	66	86	69	72	0.074	10.38	0.04
87	14.256	14.917	0.17	0.17	2.32	76	-4.81	1.78	73	-2.4	142	0.090	100	99	4.2	-0.2	677	510	280	431	536	487	593	87	66	86	68	72	0.074	10.31	0.04
88	14.423	15.091	0.17	0.17	2.33	76	-4.63	1.77	73	-2.3	142	0.090	100	100	4.0	-0.16	673	514	285	434	538	489	590	87	65	86	68	72	0.074	10.4	0.03
89	14.589	15.264	0.17	0.17	2.31	76	-4.64	1.77	73	-2.1	139	0.090	99	99	3.9	-0.14	671	518	293	438	540	492	587	87	65	86	67	72	0.073	10.3	0.03
90	14.755	15.438	0.17	0.17	2.31	76	-4.51	1.77	73	-2.1	139	0.090	99	100	3.7	-0.2	667	522	296	440	543	494	583	87	64	86	67	72	0.073	10.07	0.03
91	14.921	15.610	0.17	0.17	2.30	76	-4.74	1.78	73	-2.4	140	0.090	99	99	3.6	-0.1	662	526	315	444	544	498	581	87	64	86	67	72	0.073	9.98	0.03
92	15.086	15.784	0.17	0.17	2.31	76	-4.79	1.78	73	-2.3	139	0.090	99	100	3.4	-0.2	659	530	307	446	546	498	578	87	64	86	66	72	0.072	10	0.03
93	15.253	15.958	0.17	0.17	2.32	76	-4.69	1.78	74	-2.1	139	0.090	100	99	3.3	-0.1	656	534	308	448	547	499	579	87	63	86	66	72	0.072	10.19	0.03
94	15.420	16.132	0.17	0.17	2.34	77	-4.76	1.77	74	-2.1	138	0.090	100	99	3.1	-0.2	655	538	309	451	549	500	579	87	63	86	66	72	0.072	10.3	0.01
95	15.588	16.305	0.17	0.17	2.35	77	-4.84	1.79	74	-2.1	137	0.090	100	99	3.0	-0.12	649	542	307	453	550	500	575	87	63	86	66	72	0.072	9.98	0.01
96	15.754	16.479	0.17	0.17	2.30	77	-4.59	1.78	74	-2.1	136	0.090	99	99	2.9	-0.08	646	546	307	456	551	501	571	87	62	86	65	71	0.072	9.77	0
97	15.921	16.653	0.17	0.17	2.33	77	-4.86	1.78	74	-2.1	135	0.090	99	99	2.7	-0.2	640	549	305	458	553	501	566	86	62	85	65	72	0.071	9.55	0
98	16.088	16.827	0.17	0.17	2.32	77	-4.81	1.79	74	-2.3	135	0.090	99	99	2.6	-0.1	637	553	307	462	556	503	564	86	62	85	65	71	0.071	9.43	0.01
99	16.255	17.001	0.17	0.17	2.34	77	-4.51	1.79	74	-2.1	135	0.090	99	99	2.5	-0.1	635	556	306	465	557	504	567	86	62	85	65	71	0.071	9.7	0
100	16.422	17.175	0.17	0.17	2.34	77	-4.86	1.79	74	-2.4	134	0.090	99	99	2.3	-0.2	635	560	308	467	560	506	566	86	61	85	64	72	0.071	9.79	0
101	16.590	17.349	0.17	0.17	2.35	77	-4.51	1.78	74	-2.1	135	0.090	100	99	2.2	-0.1	634	563	307	469	560	507	565	86	61	85	64	72	0.071	9.65	0
102	16.757	17.522	0.17	0.17	2.31	77	-4.45	1.79	74	-2.2	134	0.090	99	98	2.1	-0.1	635	566	305	472	562	508	563	86	61	85	64	72	0.071	9.61	0
103	16.924	17.697	0.17	0.18	2.34	77	-4.76	1.79	74	-2.3	134	0.090	99	100	2.0	-0.1	631	568	305	474	564	508	561	86	61	85	64	72	0.070	9.56	0
104	17.092	17.871	0.17	0.17	2.33	77	-4.73	1.78	74	-2.4	133	0.090	100	99	1.8	-0.2	632	571	303	477	564	509	559	86	61	85	64	71	0.070	9.51	0
Avg/Tot	17.092	17.871	0.16	0.17	2.27	72	1.76	70	141	0.088	100	100										449.0			69	85	68	69	0.071		

## Wood Heater Lab Data

Manufacturer: GHP Group                      Equipment Numbers: \_\_\_\_\_  
 Model: PH1800WS  
 Tracking No.: 2402  
 Project No.: 0418WS017E  
 Run #: 1  
 Date: 1/29/20

**TRAIN 1 (First Hour emissions)**

Sample Component	Reagent	Filter, Probe or Dish #	Weights		
			Final, mg	Tare, mg	Particulate, mg
B. Front filter catch	Filter	T190S,T191S	177.4	175.2	2.2
C. Rear filter catch	Filter				0.0
D. Probe catch*	Probe				0.0
E. Filter seals catch*	Seals				0.0

**Sub-Total**    Total Particulate, mg:    **2.2**

**TRAIN 1 (Post First Hour Change-out)**

Sample Component	Reagent	Filter, Probe or Dish #	Weights		
			Final, mg	Tare, mg	Particulate, mg
B. Front filter catch	Filter	T188AP	171.8	171.4	0.4
C. Rear filter catch	Filter				0.0
D. Probe catch*	Probe	OES3	114770.0	114769.6	0.4
E. Filter seals catch*	Seals	R915	3537.5	3537.3	0.2

**Sub-Total**    Total Particulate, mg:    **1.0**

**Train 1 Aggregate**    Total Particulate, mg:    **3.2**

**TRAIN 2**

Sample Component	Reagent	Filter, Probe or Dish #	Weights		
			Final, mg	Tare, mg	Particulate, mg
A. Front filter catch	Filter	T188BP	176.7	175.0	1.7
B. Rear filter catch	Filter	T192S	88.2	87.3	0.9
C. Probe catch*	Probe	4	114859.1	114858.7	0.4
D. Filter seals catch*	Seals	R916	3322.1	3321.5	0.6

Total Particulate, mg:    **3.6**

**AMBIENT**

Sample Component	Reagent	Filter # or Probe #	Weights		
			Final, mg	Tare, mg	Particulate, mg
A. Front filter catch*	Filter				0.0

Total Particulate, mg:    **0.0**

\*Particulate catch that results in a negative number, is assumed to be zero for probes and seals, negative numbers for filters are assumed to be part of the seal weight.

Component	Equations:
A. Front filter catch	Final (mg) - Tare (mg) = Particulate, mg
B. Rear filter catch	Final (mg) - Tare (mg) = Particulate, mg
C. Probe catch	Final (mg) - Tare (mg) = Particulate, mg

Technician Signature: 

## Wood Heater Test Results

Manufacturer: GHP Group  
 Model: PH1800WS  
 Project No.: 0418WS017E  
 Tracking No.: 2402  
 Run: 1  
 Test Date: 01/29/20

Burn Rate	<b>4.89 kg/hr dry</b>
Average Tunnel Temperature	141 degrees Fahrenheit
Average Gas Velocity in Dilution Tunnel - vs	20.27 feet/second
Average Gas Flow Rate in Dilution Tunnel - Qsd	12167.4 dscf/hour
Average Delta p	0.088 inches H2O
Total Time of Test	104 minutes

	AMBIENT	SAMPLE TRAIN 1	SAMPLE TRAIN 2	FIRST HOUR FILTER (TRAIN 1)
Total Sample Volume - Vm	0.000 cubic feet	17.092 cubic feet	17.871 cubic feet	9.775 cubic feet
Average Gas Meter Temperature	69 degrees Fahrenheit	72 degrees Fahrenheit	70 degrees Fahrenheit	69 degrees Fahrenheit
Total Sample Volume (Standard Conditions) - Vmstd	0.000 dscf	16.628 dscf	17.382 dscf	9.553 dscf
Total Particulates - m <sub>T</sub>	0 mg	3.2 mg	3.6 mg	2.2 mg
Particulate Concentration (dry-standard) - C <sub>p</sub> /C <sub>s</sub>	0.000000 grams/dscf	0.00019 grams/dscf	0.00021 grams/dscf	0.00023 grams/dscf
Total Particulate Emissions - E <sub>T</sub>	0.00 grams	4.06 grams	4.37 grams	2.80 grams
Particulate Emission Rate	0.00 grams/hour	2.34 grams/hour	2.52 grams/hour	2.80 grams/hour
Emissions Factor		0.48 g/kg	0.51 g/kg	-8.45 g/kg
Difference from Average Total Particulate Emissions		0.15 grams	0.15 grams	

**Dual Train Comparison Results Are Acceptable**

FINAL AVERAGE RESULTS	
<b>Complete Test Run</b>	
Total Particulate Emissions - E <sub>T</sub>	4.21 grams
Particulate Emission Rate	<b>2.43 grams/hour</b>
Emissions Factor	0.50 grams/kg
<b>First Hour Emissions</b>	
Total Particulate Emissions - E <sub>T</sub>	2.80 grams
Particulate Emission Rate	2.80 grams/hour
Emissions Factor	-8.45 grams/kg
7.5% of Average Total Particulate Emissions	0.32 grams

QUALITY CHECKS	
<b>Filter Temps &lt; 90 °F</b>	OK
<b>Filter Face Velocity (47 mm)</b>	OK
<b>Dryer Exit Temp &lt; 80F</b>	OK
<b>Leakage Rate</b>	OK
<b>Ambient Temp (55-90°F)</b>	OK
<b>Negative Probe Weight Eval.</b>	OK
<b>Pro-Rate Variation</b>	ECK 10 MIN. INTERVAL PRO-RAT

Technician Signature: 

Adjunct to ASTM E XXXX Wood Heater Cordwood Test Method - May 10, 2017 Version  
 Cordwood Fuel Load Calculators - 10 lb/ft<sup>3</sup> Nominal Load Density  
 Core 45-65% of Total Load Weight, Remainder 35-55% of Total Load Weight  
 Values to be input manually

THIS DOCUMENT IS NOT AN ASTM STANDARD; IT IS UNDER CONSIDERATION WITHIN AN ASTM TECHNICAL COMMITTEE BUT HAS NOT RECEIVED ALL APPROVALS REQUIRED TO BECOME AN ASTM STANDARD. IT SHALL NOT BE REPRODUCED OR CIRCULATED OR QUOTED, IN WHOLE OR IN PART, OUTSIDE OF ASTM COMMITTEE ACTIVITIES EXCEPT WITH THE APPROVAL OF THE CHAIRMAN OF THE COMMITTEE HAVING JURISDICTION AND THE PRESIDENT OF THE SOCIETY. COPYRIGHT ASTM, 100 BARR HARBOR DRIVE, WEST CONSHOHOCKEN, PA 19428. ALL RIGHTS RESERVED.

For All Usable Firebox Volumes - High Fire Test Only				
Nominal Required Load Density (wet basis)	10	lb/ft <sup>3</sup>		
Usable Firebox Volume	1.78	ft <sup>3</sup>		
Total Nom. Load Wt. Target	17.80	lb		
Total Load Wt. Allowable Range	16.90	to 18.70	lb	
Core Target Wt. Allowable Range	8.00	to 11.60	lb	
Remainder Load Wt. Allowable Range	6.20	to 9.80	lb	
				Mid-Point
Core Load Pc. Wt. Allowable Range	2.70	to 4.50	lb	3.60
Remainder Load Pc. Wt. Allowable Range	1.80	to 9.80	lb	5.80
	Pc. #			
Core Load Piece Wt. Actual	1	3.10	lb	In Range
	2	3.10	lb	In Range
	3	4.20	lb	In Range
Core Load Total. Wt. Actual		10.40	lb	In Range
	Pc. #			
Remainder Load Piece Wt.	1	5.20	lb	In Range
(1 to 3 Pcs.)	2	2.40	lb	In Range
	3		lb	NA
Remainder Load Tot. Wt. Act		7.60	lb	In Range
Total Load Wt. Actual		18.00	lb	In Range
Core % of Total Wt.		58%		In Range 45-65%
Remainder % of Total Wt.		42%		In Range 35-55%
Actual Load % of Nominal Target		101%		In Range 95-105%
Actual Fuel Load Density		10.1	lb/ft <sup>3</sup>	
<u>Kindling and Start-up Fuel</u>				
Maximum Kindling Wt. (20% of Tot. Load Wt.)		3.60	lb	
Actual Kindling Wt.		3.60	lb	In Range 20.0%
Maximum Start-up Fuel Wt. (30% of Tot. Load Wt.)		5.40	lb	
Actual Start-up Fuel Wt.		5.40	lb	In Range 30.0%
Allowable Residual Start-up Fuel Wt. Range	1.8	to 3.6	lb	Mid-Point
Actual Residual Start-up Fuel Wt.		1.8	lb	In Range 2.7
Total Wt. All Fuel Added (wet basis)		27.00	lb	
<u>High Fire Test Run End Point Range</u>				
	Low		High	Mid-Point
Based on Fuel Load Wt. (w/tares)	1.6	to 2.0	lb	1.8
Actual Fuel Load Ending Wt.		1.8	lb	In Range

Fuel Piece Moisture Reading (%-dry basis)						
1	2	3	Ave.		Pc. Wt. Dry Basis	
24.7	20.2	18	21.0	In Range	2.56 lb	1.16 kg
28	22.4	23.7	24.7	In Range	2.49 lb	1.13 kg
25.8	21.7	23	23.5	In Range	3.40 lb	1.54 kg
23.1	20.9	23.4	22.5	In Range	4.25 lb	1.93 kg
27	22.4	22.4	23.9	In Range	1.94 lb	0.88 kg
			NA	NA	NA lb	NA kg
Total Load Ave. MC (%-dry basis)			23.0	In Range		
Total Load Ave. MC % (wet basis)			18.7			
Total Test Load Weight (dry basis)					14.63 lb	6.64 kg
<u>Kindling Moisture (%-dry basis)</u>						
12	9.6	12	11.2	In Range	3.24 lb	1.47 kg
<u>Start-up Fuel Moisture Readings (%-dry basis)</u>						
19.3	19.5	19.8	19.5	In Range	4.52 lb	2.05 kg
Total Wt. All Fuel Added (dry basis)					22.39 lb	10.15 kg
Total Wt. All Fuel Burned (dry basis)					18.8 lb	8.5 kg

### Wood Heater Run Sheets

Client: GHP Group Project Number: 0418WS017E Run Number: 1  
 Model: PH1800WS Tracking Number: 2402 Date: 1/27/20  
 Test Crew: D. Davis  
 OMNI Equipment ID numbers: \_\_\_\_\_

#### Wood Heater Run Notes

##### Air Control Settings

Primary:

*fully open*

Secondary: fixed

Tertiary/Pilot: w/p

Fan: On High L

##### Preburn Notes

Time	Notes
<i>Ø</i>	<i>Bypass open, door open, torch used for 1 min then door to 12" open. Door closed @ 2:25, bypass closed @ 2:25. Fan on @ <sup>High</sup> 5:0 min Tared 1.9 lbs</i>

##### Test Notes

Sketch test fuel configuration:

*See photo*

Start up procedures & Timeline:

Bypass: Not used  
 Fuel loaded by: less than 1 minute  
 Door closed at: by 1:00 minutes  
 Primary air: fully open entire test

Notes: fan on high entire test

Time	Notes
<i>≈ 35</i>	<i>changed front filter in train A &amp; B due to plugging</i>
<i>60</i>	<i>changed front filter in train A</i>

Technician Signature: *D. Davis*

Date: 2/4/2020

### Wood Heater Run Sheets

Client: GHP Group Project Number: 0418WS017E Run Number: 1  
 Model: PH1800WS Tracking Number: 2402 Date: 1/23/20  
 Test Crew: B. Davis  
 OMNI Equipment ID numbers: \_\_\_\_\_

### Wood Heater Supplemental Data

Start Time: 1020 Booth #: N/A

Stop Time: 1204

**Stack Gas Leak Check:**

Initial: good Final: good

**Sample Train Leak Check:**

A: 0.0 @ 8 "Hg  
 B: 0.0 @ 8 "Hg

**Calibrations:** Span Gas CO<sub>2</sub>: 10.08 CO: 2.53

	Pre Test		Post Test	
	Zero	Span	Zero	Span
Time	<u>1000</u>	<u>1000</u>	<u>see</u>	<u>test 2</u>
CO <sub>2</sub>	<u>0.00</u>	<u>10.08</u>		
CO	<u>0.00</u>	<u>2.53</u>		

Air Velocity (ft/min): Initial: 250 Final: 250

Scale Audit (lbs): Initial: 10.0 Final: 10.0

Pitot Tube Leak Test: Initial: good Final: good

Stack Diameter (in): 6"

Induced Draft: 0.0

% Smoke Capture: not

Flue Pipe Cleaned Prior to First Test in Series:

Date: 1/23/20 Initials: B. Davis

	Initial	Middle	Ending
P <sub>b</sub> (in/Hg)	<u>29.52</u>		<u>29.52</u>
RH (%)	<u>54</u>		<u>50</u>
Ambient (°F)	<u>65</u>		<u>71</u>

Tunnel Traverse		
Microtector Reading	dP (in H <sub>2</sub> O)	T(°F)
	<u>.100</u>	<u>69</u>
	<u>.098</u>	<u>69</u>
	<u>.106</u>	<u>69</u>
	<u>.090</u>	<u>69</u>
	<u>.080</u>	<u>69</u>
	<u>.098</u>	<u>69</u>
	<u>.100</u>	<u>69</u>
	<u>.084</u>	<u>69</u>
Center:		
	<u>.104</u>	<u>69</u>

Background Filter Volume: N/A

Tunnel Static Pressure (in H <sub>2</sub> O):	
Beginning of Test	End of Test
<u>-.26</u>	<u>-.26</u>

Technician Signature: B. Davis

Date: 2/4/2020

# **Run 1**

## **High Burn 1-minute data**

**Efficiency and Heat Output Results**  
**Kindling and start-up fuel removed from calculations**




### Wood Heater Test Data

Run: 1

Manufacturer: GHP Group  
 Model: PH1800WS  
 Tracking No.: 2402  
 Project No.: 0418WS017E  
 Test Date: 29-Jan-20  
 Beginning Clock Time: 10:20  
 Total Sampling Time: 72 min  
 Recording Interval: 1 min  
 Background Sample Volume: \_\_\_\_\_ cubic feet  
 Meter Box Y Factor: 0.988 (1) 0.985 (2) \_\_\_\_\_ (Amb)  
 Barometric Pressure: Begin Middle End Average  
29.52 29.52 29.52 0  
 OMNI Equipment Numbers: \_\_\_\_\_

PM Control Modules: 371, 372  
 Dilution Tunnel MW(dry): 29.00 lb/lb-mole  
 Dilution Tunnel MW(wet): 28.78 lb/lb-mole  
 Dilution Tunnel H2O: 2.00 percent  
 Dilution Tunnel Static: -0.260 "H2O  
 Tunnel Area: 0.19635 ft<sup>2</sup>  
 Pitot Tube Cp: 0.99  
 Avg. Tunnel Velocity: #DIV/0! ft/sec.  
 Initial Tunnel Flow: #DIV/0! scfm  
 Average Tunnel Flow: #DIV/0! scfm  
 Post-Test Leak Check (1): 0.000 cfm @ 8 in. Hg  
 Post-Test Leak Check (2): 0.000 cfm @ 8 in. Hg  
 Average Test Piece Fuel Moisture: 23.11 Dry Basis %

Technician Signature: 

Velocity Traverse Data									
	Pt.1	Pt.2	Pt.3	Pt.4	Pt.5	Pt.6	Pt.7	Pt.8	Center
Initial dP									
Temp:									

V<sub>strav</sub> \_\_\_\_\_ ft/sec      V<sub>scent</sub> \_\_\_\_\_ ft/sec      F<sub>p</sub> \_\_\_\_\_ °F

Elapsed Time (min)	Particulate Sampling Data														Fuel Weight (lb)		Temperature Data (°F)										Stack Gas Data					
	Gas Meter 1 (ft <sup>3</sup> )	Gas Meter 2 (ft <sup>3</sup> )	Sample Rate 1 (cfm)	Sample Rate 2 (cfm)	Orifice dH 1 ("H <sub>2</sub> O)	Meter 1 Temp (°F)	Meter 1 Vacuum ("Hg)	Orifice dH 2 ("H <sub>2</sub> O)	Meter 2 Temp (°F)	Meter 2 Vacuum ("Hg)	Dilution Tunnel (°F)	Dilution Tunnel Center dP	Pro. Rate 1	Pro. Rate 2	Scale Reading	Weight Change	Firebox Top	Firebox Bottom	Firebox Back	Firebox Left	Firebox Right	Avg. Stove Surface	Stack	Filter 1	Dryer Exit 1	Filter 2	Dryer Exit 2	Ambient	Draft ("H <sub>2</sub> O)	CO <sub>2</sub> (%)	CO (%)	
0															16.2		575	212	217	273	315	318		448	88	67	85	65	67	0.065	5.62	0.06
1															15.5	-0.7	557	224	217	282	322	320		510	87	67	85	65	68	0.065	6.4	0.75
2															15.2	-0.3	598	235	212	292	331	334		614	86	67	84	65	68	0.068	12.95	0.56
3															14.9	-0.3	642	247	208	300	338	347		640	85	68	83	66	69	0.073	13.43	0.26
4															14.6	-0.3	666	258	201	308	345	356		640	85	68	83	66	68	0.080	12.27	0.34
5															14.3	-0.3	684	269	194	313	351	362		636	87	68	83	67	68	0.080	11.78	0.31
6															14.0	-0.3	689	278	186	317	355	365		632	88	68	84	67	69	0.079	11.21	0.34
7															13.7	-0.28	698	288	182	321	362	370		634	88	68	85	67	69	0.078	11.1	0.35
8															13.5	-0.22	702	296	180	323	364	373		641	88	68	85	68	68	0.079	11.55	0.35
9															13.2	-0.32	711	304	177	325	369	377		659	88	69	85	68	69	0.079	12.08	0.36
10															12.9	-0.28	724	312	175	328	373	382		675	88	69	85	68	69	0.081	14.14	0.25
11															12.5	-0.36	736	319	174	329	378	387		681	88	69	85	69	69	0.082	13.89	0.23
12															12.3	-0.28	744	326	174	330	381	391		683	88	69	85	69	68	0.083	13.7	0.22
13															11.9	-0.36	751	333	175	332	386	395		681	88	70	85	69	69	0.083	13.41	0.2
14															11.6	-0.3	755	339	174	333	391	398		680	88	70	85	70	69	0.083	13.23	0.21
15															11.4	-0.22	755	344	174	335	394	400		680	89	70	85	70	69	0.082	13.22	0.2
16															11.1	-0.28	757	350	174	337	400	404		677	88	70	85	70	69	0.082	13.06	0.19
17															10.8	-0.3	755	356	174	339	405	406		673	88	71	85	71	69	0.082	12.88	0.18
18															10.5	-0.3	753	361	176	340	410	408		672	88	71	85	71	69	0.082	12.79	0.18
19															10.2	-0.26	749	366	177	343	416	410		666	87	71	85	72	69	0.082	12.64	0.18
20															10.0	-0.24	748	370	178	345	423	413		663	87	71	85	72	69	0.081	12.36	0.17
21															9.7	-0.3	745	375	178	348	428	415		657	87	72	85	72	68	0.081	12.24	0.17
22															9.4	-0.28	741	379	178	349	432	416		655	87	72	85	73	69	0.080	12.14	0.16
23															9.2	-0.22	740	384	180	352	439	419		652	87	72	85	73	70	0.080	12.03	0.14
24															8.9	-0.3	736	388	181	354	444	421		649	87	72	86	73	69	0.080	11.89	0.14
25															8.7	-0.2	733	392	182	357	449	423		646	87	73	86	73	70	0.080	11.81	0.14
26															8.5	-0.2	730	396	184	359	452	424		645	87	73	86	74	70	0.079	11.88	0.13
27															8.2	-0.3	730	400	186	363	457	427		645	87	73	86	74	70	0.079	11.91	0.11
28															8.0	-0.2	726	404	187	365	461	429		640	87	73	86	74	69	0.079	11.75	0.11
29															7.7	-0.3	724	408	188	366	465	430		638	87	74	86	75	70	0.079	11.65	0.11
30															7.5	-0.2	721	412	190	369	469	432		637	84	74	86	75	70	0.079	11.6	0.11
31															7.3	-0.2	717	416	193	370	472	434		636	86	74	86	75	70	0.078	11.64	0.11
32															7.0	-0.3	718	420	196	373	475	436		634	87	74	86	76	70	0.078	11.63	0.12
33															6.8	-0.2	717	424	199	376	478	439		634	87	75	86	76	70	0.078	11.6	0.12
34															6.5	-0.3	717	428	199	377	481	440		634	87	75	86	76	71	0.078	11.65	0.11
35															6.3	-0.2	716	431	202	379	485	443		636	87	75	86	77	70	0.078	11.78	0.11
36															6.1	-0.2	717	435	206	383	487	446		633	87	75	86	77	71	0.078	11.66	0.11




### Wood Heater Test Data

Run: 1

Manufacturer: GHP Group  
 Model: PH1800WS  
 Tracking No.: 2402  
 Project No.: 0418WS017E  
 Test Date: 29-Jan-20  
 Beginning Clock Time: 10:20  
 Total Sampling Time: 72 min  
 Recording Interval: 1 min  
 Background Sample Volume: \_\_\_\_\_ cubic feet  
 Meter Box Y Factor: 0.988 (1) 0.985 (2) \_\_\_\_\_ (Amb)  
 Barometric Pressure: Begin Middle End Average  
29.52 29.52 29.52 0  
 OMNI Equipment Numbers: \_\_\_\_\_

PM Control Modules: 371.372  
 Dilution Tunnel MW(dry): 29.00 lb/lb-mole  
 Dilution Tunnel MW(wet): 28.78 lb/lb-mole  
 Dilution Tunnel H2O: 2.00 percent  
 Dilution Tunnel Static: -0.260 "H2O  
 Tunnel Area: 0.19635 ft<sup>2</sup>  
 Pitot Tube Cp: 0.99  
 Avg. Tunnel Velocity: #DIV/0! ft/sec.  
 Initial Tunnel Flow: #DIV/0! scfm  
 Average Tunnel Flow: #DIV/0! scfm  
 Post-Test Leak Check (1): 0.000 cfm @ 8 in. Hg  
 Post-Test Leak Check (2): 0.000 cfm @ 8 in. Hg  
 Average Test Piece Fuel Moisture: 23.11 Dry Basis %

Technician Signature: 

Velocity Traverse Data									
	Pt.1	Pt.2	Pt.3	Pt.4	Pt.5	Pt.6	Pt.7	Pt.8	Center
Initial dP									
Temp:									

$V_{strav}$  \_\_\_\_\_ ft/sec       $V_{scent}$  \_\_\_\_\_ ft/sec       $F_p$  \_\_\_\_\_

Elapsed Time (min)	Particulate Sampling Data												Fuel Weight (lb)		Temperature Data (°F)										Stack Gas Data										
	Gas Meter 1 (ft <sup>3</sup> )	Gas Meter 2 (ft <sup>3</sup> )	Sample Rate 1 (cfm)	Sample Rate 2 (cfm)	Orifice dH 1 ("H <sub>2</sub> O)	Meter 1 Temp (°F)	Meter 1 Vacuum ("Hg)	Orifice dH 2 ("H <sub>2</sub> O)	Meter 2 Temp (°F)	Meter 2 Vacuum ("Hg)	Dilution Tunnel (°F)	Dilution Tunnel Center dP	Pro. Rate 1	Pro. Rate 2	Scale Reading	Weight Change	Firebox Top	Firebox Bottom	Firebox Back	Firebox Left	Firebox Right	Avg. Stove Surface		Stack	Filter 1	Dryer Exit 1	Filter 2	Dryer Exit 2	Ambient	Draft ("H <sub>2</sub> O)	CO <sub>2</sub> (%)	CO (%)			

## Wood Heater Test Results

Manufacturer: GHP Group  
 Model: PH1800WS  
 Project No.: 0418WS017E  
 Tracking No.: 2402  
 Run: 1  
 Test Date: 01/29/20

Burn Rate	<b>4.84 kg/hr dry</b>
Total Time of Test	72 minutes

	AMBIENT	SAMPLE TRAIN 1	SAMPLE TRAIN 2	FIRST HOUR FILTER (TRAIN 1)
<b>#DIV/0!</b>				

	FINAL AVERAGE RESULTS
<b>Complete Test Run</b>	

QUALITY CHECKS	
Ambient Temp (55-90°F)	OK

Technician Signature: 

# Wood Heater Efficiency Results - CSA B415.1

**Manufacturer:** GHP Group  
**Model:** PH1800WS  
**Date:** 01/29/20  
**Run:** 1  
**Control #:** 0418WS017E  
**Test Duration:** 72  
**Output Category:** IV

**Technician Signature:** 

**Test Results in Accordance with CSA B415.1-09**

	HHV Basis	LHV Basis
Overall Efficiency	68.8%	73.7%
Combustion Efficiency	98.8%	98.8%
Heat Transfer Efficiency	70%	74.6%

Output Rate (kJ/h)	66,190	62,789	(Btu/h)
Burn Rate (kg/h)	4.98	10.97	(lb/h)
Input (kJ/h)	96,222	91,277	(Btu/h)

Test Load Weight (dry kg)	5.97	13.16	dry lb
MC wet (%)	18.77402935		
MC dry (%)	23.11		
Particulate (g)	#DIV/0!		
CO (g)	113		
Test Duration (h)	1.20		

Emissions	Particulate	CO
g/MJ Output	#DIV/0!	1.42
g/kg Dry Fuel	#DIV/0!	18.95
g/h	#DIV/0!	94.31
lb/MM Btu Output	#DIV/0!	3.31

Air/Fuel Ratio (A/F)	9.58
----------------------	------

VERSION:                      2.2                      12/14/2009

Adjunct to ASTM E XXXX Wood Heater Cordwood Test Method - May 10, 2017 Version  
 Cordwood Fuel Load Calculators - 10 lb/ft<sup>3</sup> Nominal Load Density  
 Core 45-65% of Total Load Weight, Remainder 35-55% of Total Load Weight  
 Values to be input manually

THIS DOCUMENT IS NOT AN ASTM STANDARD; IT IS UNDER CONSIDERATION WITHIN AN ASTM TECHNICAL COMMITTEE BUT HAS NOT RECEIVED ALL APPROVALS REQUIRED TO BECOME AN ASTM STANDARD. IT SHALL NOT BE REPRODUCED OR CIRCULATED OR QUOTED, IN WHOLE OR IN PART, OUTSIDE OF ASTM COMMITTEE ACTIVITIES EXCEPT WITH THE APPROVAL OF THE CHAIRMAN OF THE COMMITTEE HAVING JURISDICTION AND THE PRESIDENT OF THE SOCIETY. COPYRIGHT ASTM, 100 BARR HARBOR DRIVE, WEST CONSHOHOCKEN, PA 19428. ALL RIGHTS RESERVED.

For All Usable Firebox Volumes - High Fire Test Only				
Nominal Required Load Density (wet basis)	10	lb/ft <sup>3</sup>		
Usable Firebox Volume	1.78	ft <sup>3</sup>		
Total Nom. Load Wt. Target	17.80	lb		
Total Load Wt. Allowable Range	16.90	to 18.70	lb	
Core Target Wt. Allowable Range	8.00	to 11.60	lb	
Remainder Load Wt. Allowable Range	6.20	to 9.80	lb	
				Mid-Point
Core Load Pc. Wt. Allowable Range	2.70	to 4.50	lb	3.60
Remainder Load Pc. Wt. Allowable Range	1.80	to 9.80	lb	5.80
	Pc. #			
Core Load Piece Wt. Actual	1	3.10	lb	In Range
	2	3.10	lb	In Range
	3	4.20	lb	In Range
Core Load Total. Wt. Actual		10.40	lb	In Range
	Pc. #			
Remainder Load Piece Wt.	1	5.20	lb	In Range
(1 to 3 Pcs.)	2	2.40	lb	In Range
	3		lb	NA
Remainder Load Tot. Wt. Act		7.60	lb	In Range
Total Load Wt. Actual		18.00	lb	In Range
Core % of Total Wt.		58%		In Range 45-65%
Remainder % of Total Wt.		42%		In Range 35-55%
Actual Load % of Nominal Target		101%		In Range 95-105%
Actual Fuel Load Density		10.1	lb/ft <sup>3</sup>	
<u>Kindling and Start-up Fuel</u>				
Maximum Kindling Wt. (20% of Tot. Load Wt.)		3.60	lb	
Actual Kindling Wt.		3.60	lb	In Range 20.0%
Maximum Start-up Fuel Wt. (30% of Tot. Load Wt.)		5.40	lb	
Actual Start-up Fuel Wt.		5.40	lb	In Range 30.0%
Allowable Residual Start-up Fuel Wt. Range	1.8	to 3.6	lb	Mid-Point
Actual Residual Start-up Fuel Wt.		1.8	lb	In Range 2.7
Total Wt. All Fuel Added (wet basis)		27.00	lb	
<u>High Fire Test Run End Point Range</u>				
	Low		High	Mid-Point
Based on Fuel Load Wt. (w/tares)	1.6	to	2.0	lb 1.8
Actual Fuel Load Ending Wt.		1.8	lb	In Range

Fuel Piece Moisture Reading (%-dry basis)						
1	2	3	Ave.		Pc. Wt. Dry Basis	
24.7	20.2	18	21.0	In Range	2.56 lb	1.16 kg
28	22.4	23.7	24.7	In Range	2.49 lb	1.13 kg
25.8	21.7	23	23.5	In Range	3.40 lb	1.54 kg
23.1	20.9	23.4	22.5	In Range	4.25 lb	1.93 kg
27	22.4	22.4	23.9	In Range	1.94 lb	0.88 kg
			NA	NA	NA lb	NA kg
Total Load Ave. MC (%-dry basis)			23.0	In Range		
Total Load Ave. MC % (wet basis)			18.7			
Total Test Load Weight (dry basis)					14.63 lb	6.64 kg
<u>Kindling Moisture (%-dry basis)</u>						
12	9.6	12	11.2	In Range	3.24 lb	1.47 kg
<u>Start-up Fuel Moisture Readings (%-dry basis)</u>						
19.3	19.5	19.8	19.5	In Range	4.52 lb	2.05 kg
Total Wt. All Fuel Added (dry basis)					22.39 lb	10.15 kg
Total Wt. All Fuel Burned (dry basis)					18.8 lb	8.5 kg

# **Run 1**

## **High Burn 10-minute data**

### **Proportional Rate Verification**

This data set is presented to verify that when proportional rates are calculated at the required 10-minute interval, required specification that only one reading can be outside of the 90% to 110% are maintained.

### Wood Heater Test Data


Run: **1**

Manufacturer: GHP Group  
 Model: PH1800WS  
 Tracking No.: 2402  
 Project No.: 0418WS017E  
 Test Date: 29-Jan-20  
 Beginning Clock Time: 10:20  
 Meter Box Y Factor: 0.988 (1) 0.985 (2) \_\_\_\_\_ (Amb)  
 Barometric Pressure: Begin Middle End Average  
29.52 29.52 29.52 0  
 OMNI Equipment Numbers: \_\_\_\_\_

Total Sampling Time: 104 min  
 Recording Interval: 10 min

Background Sample Volume: \_\_\_\_\_ cubic feet

PM Control Modules: 371, 372  
 Dilution Tunnel MW (dry): 29.00 lb/lb-mole  
 Dilution Tunnel MW (wet): 28.78 lb/lb-mole  
 Dilution Tunnel H2O: 2.00 percent  
 Dilution Tunnel Static: -0.260 "H2O  
 Tunnel Area: 0.19635 ft<sup>2</sup>  
 Pitot Tube Cp: 0.99  
 Avg. Tunnel Velocity: 20.35 ft/sec.  
 Initial Tunnel Flow: 233.1 scfm  
 Average Tunnel Flow: 205.5 scfm  
 Post-Test Leak Check (1): 0.000 cfm @ 8 in. Hg  
 Post-Test Leak Check (2): 0.000 cfm @ 8 in. Hg  
 Average Test Piece Fuel Moisture: 23.11 Dry Basis %

Technician Signature: 

Velocity Traverse Data									
	Pt.1	Pt.2	Pt.3	Pt.4	Pt.5	Pt.6	Pt.7	Pt.8	Center
Initial dP	0.100	0.098	0.106	0.090	0.080	0.098	0.100	0.084	0.104
Temp:	69	69	69	69	69	69	69	69	69
	V <sub>strav</sub> <u>20.63</u> ft/sec			V <sub>scnt</sub> <u>21.54</u> ft/sec			F <sub>p</sub> <u>0.958</u>		

Elapsed Time (min)	Particulate Sampling Data													Fuel Weight (lb)		Temperature Data (°F)										Stack Gas Data						
	Gas Meter 1 (ft <sup>3</sup> )	Gas Meter 2 (ft <sup>3</sup> )	Sample Rate 1 (cfm)	Sample Rate 2 (cfm)	Orifice dH 1 ("H <sub>2</sub> O)	Meter 1 Temp (°F)	Meter 1 Vacuum ("Hg)	Orifice dH 2 ("H <sub>2</sub> O)	Meter 2 Temp (°F)	Meter 2 Vacuum ("Hg)	Dilution Tunnel (°F)	Dilution Tunnel Center dP	Pro. Rate 1	Pro. Rate 2	Scale Reading	Weight Change	Firebox Top	Firebox Bottom	Firebox Back	Firebox Left	Firebox Right	Avg. Stove Surface	Stack	Filter 1	Dryer Exit 1	Filter 2	Dryer Exit 2	Ambient	Draft ("H <sub>2</sub> O)	CO <sub>2</sub> (%)	CO (%)	
0	0.000	0.000			2.50	67	-2.37	2.05	66	-1	69	0.100			8.9		62	59	60	61	60	60		66	84	63	83	59	65		0.05	0
10	1.620	1.712	0.16	0.17	2.26	67	-4.02	1.76	66	-2	118	0.090	98	99	6.8	-2.1	457	63	100	78	90	158		488	85	70	84	61	66		10.07	0.19
20	3.251	3.415	0.16	0.17	2.25	68	-4.23	1.78	67	-2.2	144	0.090	101	100	4.1	-2.7	627	110	139	144	169	238		611	88	73	86	63	67		13.58	0.21
30	4.878	5.135	0.16	0.17	2.28	69	-4.53	1.77	67	-2.2	132	0.090	99	100	2.1	-2	610	191	203	254	289	309		548	87	67	85	64	68		9.25	0.03
40	6.492	6.752	0.16	0.16	2.26	70	-4.31	1.77	68	-2.2	153	0.090	100	96	15.3	13.2	702	296	180	323	364	373		641	88	68	85	68	68		11.55	0.35
50	8.126	8.489	0.16	0.17	2.29	71	-5.01	1.82	69	-2.3	156	0.080	107	109	12.3	-3	753	361	176	340	410	408		672	88	71	85	71	69		12.79	0.18
60	9.775	10.235	0.16	0.17	2.31	73	-4.94	1.82	70	-2.1	152	0.090	102	103	9.8	-2.5	726	404	187	365	461	429		640	87	73	86	74	69		11.75	0.11
70	11.433	11.977	0.17	0.17	2.31	74	-4.47	1.81	71	-2.2	148	0.090	102	102	7.5	-2.3	717	442	211	386	492	450		631	87	76	86	78	71		11.54	0.12
80	13.091	13.710	0.17	0.17	2.31	75	-4.67	1.77	72	-2.3	146	0.090	101	101	5.5	-2	707	481	250	410	520	474		616	87	70	86	72	71		11.15	0.05
90	14.755	15.438	0.17	0.17	2.31	76	-4.51	1.77	73	-2.1	139	0.090	101	100	3.7	-1.8	667	522	296	440	543	494		583	87	64	86	67	72		10.07	0.03
100	16.422	17.175	0.17	0.17	2.34	77	-4.86	1.79	74	-2.4	134	0.090	100	100	2.3	-1.4	635	560	308	467	560	506		566	86	61	85	64	72		9.79	0
110	17.092	17.871	0.07	0.07	2.33	77	-4.73	1.78	74	-2.4	133	0.090	101	100	1.8	-0.5	632	571	303	477	564	509		559	86	61	85	64	71		9.51	0
Avg/Tot	17.092	17.871	0.16	0.16	2.31	72		1.81	70		135	0.090	101	101								445.6			68	85	67	69	#DIV/0!			



## Wood Heater Test Results

Manufacturer: GHP Group  
 Model: PH1800WS  
 Project No.: 0418WS017E  
 Tracking No.: 2402  
 Run: 1  
 Test Date: 01/29/20

Burn Rate	<b>4.89 kg/hr dry</b>
Average Tunnel Temperature	135 degrees Fahrenheit
Average Gas Velocity in Dilution Tunnel - vs	20.35 feet/second
Average Gas Flow Rate in Dilution Tunnel - Qsd	12329.8 dscf/hour
Average Delta p	0.090 inches H2O
Total Time of Test	104 minutes

	AMBIENT	SAMPLE TRAIN 1	SAMPLE TRAIN 2	FIRST HOUR FILTER (TRAIN 1)
Total Sample Volume - Vm	0.000 cubic feet	17.092 cubic feet	17.871 cubic feet	9.775 cubic feet
Average Gas Meter Temperature	69 degrees Fahrenheit	72 degrees Fahrenheit	70 degrees Fahrenheit	72 degrees Fahrenheit
Total Sample Volume (Standard Conditions) - Vmstd	0.000 dscf	16.624 dscf	17.381 dscf	9.508 dscf
Total Particulates - m <sub>T</sub>	0 mg	3.2 mg	3.6 mg	2.2 mg
Particulate Concentration (dry-standard) - C <sub>p</sub> /C <sub>s</sub>	0.000000 grams/dscf	0.00019 grams/dscf	0.00021 grams/dscf	0.00023 grams/dscf
Total Particulate Emissions - E <sub>T</sub>	0.00 grams	4.11 grams	4.43 grams	2.85 grams
Particulate Emission Rate	0.00 grams/hour	2.37 grams/hour	2.55 grams/hour	2.85 grams/hour
Emissions Factor		0.48 g/kg	0.52 g/kg	-8.60 g/kg
Difference from Average Total Particulate Emissions		0.16 grams	0.16 grams	

**Dual Train Comparison Results Are Acceptable**

FINAL AVERAGE RESULTS	
<b>Complete Test Run</b>	
Total Particulate Emissions - E <sub>T</sub>	4.27 grams
Particulate Emission Rate	<b>2.46 grams/hour</b>
Emissions Factor	0.50 grams/kg
<b>First Hour Emissions</b>	
Total Particulate Emissions - E <sub>T</sub>	2.85 grams
Particulate Emission Rate	2.85 grams/hour
Emissions Factor	-8.60 grams/kg
7.5% of Average Total Particulate Emissions	0.32 grams

QUALITY CHECKS	
<b>Filter Temps &lt; 90 °F</b>	OK
<b>Filter Face Velocity (47 mm)</b>	OK
<b>Dryer Exit Temp &lt; 80F</b>	OK
<b>Leakage Rate</b>	OK
<b>Ambient Temp (55-90°F)</b>	OK
<b>Negative Probe Weight Eval.</b>	OK
<b>Pro-Rate Variation</b>	OK

Technician Signature: \_\_\_\_\_

**Run 2**


**Low Burn**

### Wood Heater Test Data

Run: **2**

Manufacturer: GHP Group  
 Model: PH1800WS  
 Tracking No.: 2402  
 Project No.: 0418WS017E  
 Test Date: 30-Jan-20  
 Beginning Clock Time: 12:26  
 Total Sampling Time: 420 min  
 Recording Interval: 5 min  
 Background Sample Volume: \_\_\_\_\_ cubic feet  
 Meter Box Y Factor: 0.992 (1) 0.989 (2) \_\_\_\_\_ (Amb)  
 Barometric Pressure: Begin Middle End Average  
29.52 29.52 29.52 0  
 OMNI Equipment Numbers: \_\_\_\_\_

PM Control Modules: 371, 372  
 Dilution Tunnel MW(dry): 29.00 lb/lb-mole  
 Dilution Tunnel MW(wet): 28.78 lb/lb-mole  
 Dilution Tunnel H2O: 2.00 percent  
 Dilution Tunnel Static: -0.278 "H2O  
 Tunnel Area: 0.19635 ft<sup>2</sup>  
 Pitot Tube Cp: 0.99  
 Avg. Tunnel Velocity: 19.80 ft/sec.  
 Initial Tunnel Flow: 227.1 scfm  
 Average Tunnel Flow: 218.1 scfm  
 Post-Test Leak Check (1): 0.000 cfm @ 6 in. Hg  
 Post-Test Leak Check (2): 0.000 cfm @ 8 in. Hg  
 Average Test Piece Fuel Moisture: 22.97 Dry Basis %

Technician Signature: 

Velocity Traverse Data									
	Pt.1	Pt.2	Pt.3	Pt.4	Pt.5	Pt.6	Pt.7	Pt.8	Center
Initial dP	0.080	0.096	0.102	0.088	0.080	0.100	0.100	0.080	0.106
Temp:	75	75	75	75	75	75	75	75	75
V <sub>strav</sub>	20.40			ft/sec			V <sub>scnt</sub>	21.87	
							ft/sec	F <sub>p</sub>	
							0.933		


Elapsed Time (min)	Particulate Sampling Data												Fuel Weight (lb)		Temperature Data (°F)												Stack Gas Data					
	Gas Meter 1 (ft <sup>3</sup> )	Gas Meter 2 (ft <sup>3</sup> )	Sample Rate 1 (cfm)	Sample Rate 2 (cfm)	Orifice dH 1 ("H <sub>2</sub> O)	Meter 1 Temp (°F)	Meter 1 Vacuum ("Hg)	Orifice dH 2 ("H <sub>2</sub> O)	Meter 2 Temp (°F)	Meter 2 Vacuum ("Hg)	Dilution Tunnel (°F)	Dilution Tunnel Center dP	Pro. Rate 1	Pro. Rate 2	Scale Reading	Weight Change	Firebox Top	Firebox Bottom	Firebox Back	Firebox Left	Firebox Right	Avg. Stove Surface	Catalyst Exit	Stack	Filter 1	Dryer Exit 1	Filter 2	Dryer Exit 2	Ambient	Draft ("H <sub>2</sub> O)	CO <sub>2</sub> (%)	CO (%)
0	0.000	0.000			1.43	78	-1.16	1.27	75	-0.6	120	0.090			20.8		479	592	416	491	540	504		424	82	52	81	58	71	0.054	4.67	0.59
5	0.861	0.920	0.17	0.18	2.29	78	-4.24	1.74	75	-2.1	135	0.090	112	114	20.0	-0.84	489	590	455	478	516	506		524	86	53	84	57	72	0.061	9.05	0.6
10	1.679	1.777	0.16	0.17	2.29	78	-4.57	1.75	75	-2	164	0.080	115	115	18.3	-1.64	717	580	441	453	484	535		694	87	54	87	54	72	0.081	16.94	0.14
15	2.514	2.635	0.17	0.17	2.33	78	-4.72	1.73	75	-2.2	126	0.090	108	106	17.0	-1.32	731	570	428	434	464	525		553	86	54	86	54	72	0.076	12.31	0.36
20	3.344	3.494	0.17	0.17	2.27	78	-4.79	1.75	75	-2.1	119	0.090	106	105	16.1	-0.9	678	559	419	421	452	506		515	87	55	87	55	71	0.070	11.77	0.53
25	4.176	4.354	0.17	0.17	2.29	78	-4.36	1.75	75	-2.1	115	0.090	106	105	15.2	-0.88	636	549	410	410	440	489		484	88	56	88	56	73	0.067	9.79	0.78
30	5.009	5.216	0.17	0.17	2.31	78	-4.32	1.74	75	-2	112	0.090	106	105	14.4	-0.82	619	539	283	400	428	454		476	87	57	87	57	72	0.066	10	0.68
35	5.839	6.085	0.17	0.17	2.28	79	-4.6	1.78	75	-2.2	108	0.090	105	105	13.7	-0.7	590	530	226	389	418	431		449	87	57	87	57	71	0.062	9.15	0.76
40	6.674	6.953	0.17	0.17	2.31	79	-4.71	1.75	75	-2.2	102	0.090	105	105	13.0	-0.7	548	520	210	378	407	413		395	86	58	86	58	71	0.057	6.67	0.92
45	7.508	7.821	0.17	0.17	2.30	79	-4.76	1.76	75	-2.3	99	0.090	105	104	12.5	-0.5	503	511	199	368	398	396		368	86	58	86	58	71	0.053	6.82	0.95
50	8.342	8.682	0.17	0.17	2.33	79	-4.35	1.75	75	-2	97	0.100	99	98	11.9	-0.6	480	503	193	358	390	385		356	85	59	85	59	70	0.050	7.32	0.91
55	9.179	9.544	0.17	0.17	2.36	79	-4.44	1.74	75	-2	95	0.100	99	98	11.4	-0.5	469	496	188	349	386	378		349	85	60	85	60	71	0.049	7.65	0.89
60	10.025	10.407	0.17	0.17	2.36	78	-4.23	1.74	75	-2.3	94	0.100	101	98	10.8	-0.6	461	490	186	339	378	371		345	85	60	85	60	70	0.049	7.95	0.88
65	10.879	11.270	0.17	0.17	2.43	78	-4.21	1.75	75	-2.2	94	0.100	102	98	10.3	-0.5	464	484	186	331	377	368		349	85	61	85	61	70	0.049	8.4	0.84
70	11.717	12.136	0.17	0.17	2.27	78	-3.95	1.75	75	-2.3	93	0.100	100	98	9.7	-0.6	467	480	186	325	377	367		350	84	61	84	61	70	0.049	8.59	0.83
75	12.547	13.003	0.17	0.17	2.29	78	-4.13	1.77	75	-2.2	93	0.100	99	98	9.2	-0.5	470	476	188	322	376	366		354	84	62	84	62	69	0.049	8.87	0.7
80	13.379	13.869	0.17	0.17	2.29	78	-3.72	1.77	75	-2.1	93	0.100	99	98	8.6	-0.6	482	472	189	319	378	368		366	84	63	84	63	69	0.050	9.73	0.65
85	14.209	14.736	0.17	0.17	2.27	78	-3.72	1.76	74	-2.3	95	0.100	99	99	8.0	-0.6	502	469	191	318	381	372		378	83	63	83	63	70	0.053	10.13	0.55
90	15.041	15.602	0.17	0.17	2.29	77	-4.01	1.75	74	-2.2	96	0.090	105	104	7.5	-0.5	516	465	197	319	385	376		391	84	63	84	63	70	0.053	10.96	0.48
95	15.873	16.469	0.17	0.17	2.30	77	-3.9	1.77	74	-2.2	97	0.090	105	104	6.9	-0.6	531	462	200	321	392	381		407	83	64	83	64	69	0.055	11.36	0.26
100	16.706	17.337	0.17	0.17	2.31	77	-3.81	1.78	74	-2.3	95	0.100	99	99	6.5	-0.4	533	459	203	326	396	383		398	84	64	84	64	69	0.055	9.92	0.3
105	17.546	18.207	0.17	0.17	2.39	77	-3.9	1.78	74	-2.3	95	0.100	100	99	6.1	-0.4	514	457	205	331	397	381		380	83	65	83	65	69	0.052	9.02	0.37
110	18.393	19.079	0.17	0.17	2.30	77	-3.84	1.79	74	-2.2	93	0.100	101	99	5.7	-0.4	503	455	208	338	399	381		373	84	65	84	65	69	0.051	9.09	0.3
115	19.227	19.952	0.17	0.17	2.31	77	-3.74	1.78	74	-2.2	93	0.090	105	105	5.3	-0.4	492	454	212	344	399	380		366	83	65	83	65	70	0.050	8.87	0.3
120	20.060	20.825	0.17	0.17	2.31	77	-3.42	1.79	74	-2.3	92	0.100	99	99	5.0	-0.3	485	453	214	349	398	380		364	84	66	84	66	69	0.049	8.98	0.25
125	20.894	21.698	0.17	0.17	2.30	77	-3.56	1.78	74	-2	92	0.100	99	99	4.6	-0.4	484	453	216	352	397	380		366	83	66	83	66	69	0.049	8.92	0.19
130	21.727	22.571	0.17	0.17	2.29	77	-3.4	1.79	74	-2.2	92	0.090	104	104	4.4	-0.2	473	453	219	355	395	379		354	83	66	83	66	69	0.048	8.65	0.23
135	22.561	23.445	0.17	0.17	2.32	77	-3.62	1.79	74	-2	90	0.100	99	99	4.1	-0.3	465	455	220	357	394	378		343	83	66	83	66	69	0.046	8.23	0.29
140	23.395	24.320	0.17	0.18	2.31	76	-3.8	1.79	74	-2.1	89	0.090	104	104	3.9	-0.2	453	457	221	360	392	377		332	83	66	83	66	69	0.045	7.55	0.37
145	24.229	25.195	0.17	0.18	2.32	76	-3.83	1.79	74	-1.9	87	0.100	99	99	3.7	-0.2	426	458	221	361	391	371		311	82	66	82	66	69	0.041	5.96	0.88
150	25.063	26.071	0.17	0.18	2.31	76	-3.65	1.80	74	-2.2	86	0.100	99	99	3.6	-0.1	400	458	218	361	391	366		294	83	66	83	66	68	0.038	5.71	0.93
155	25.898	26.947	0.17	0.18	2.31	76	-3.78	1.80	73	-2.1	84	0.100	99	99	3.5	-0.1	377	458	213	359	388	359		282	82	66	82	66	68	0.036	5.48	0.94
160	26.734	27.824	0.17	0.18	2.30	76	-3.41	1.79	73	-1.9	83	0.100	99	99	3.4	-0.1	360	457	212	357	385	354		272	82	66	82	66	69	0.034	5.44	0.92
165	27.569	28.701	0.17	0.18	2.30	76	-3.7	1.80	73	-2	83	0.100	99	99	3.3	-0.1	348	455	210	355	382	350		264	82	66	82	66	68	0.032	5.29	0.9
170	28.404	29.577	0.17	0.18	2.32	76	-3.51	1.80	73	-1.9	81	0.100	99	99	3.2	-0.1	337	453	209	352	378	346		259	81	66	81	66	67	0.031	5.24	0.9
175	29.239	30.454	0.17	0.18	2.30	76	-3.39	1.80	73	-2	81	0.100	99	99	3.0	-0.2	330	451	207	348	377	343		256	81	66	81	66	66	0.030	5.24	0.92
180	30.073	31.329	0.17	0.18	2.33	75	-3.8	1.80	73	-1.9	81	0.100	99	98	3.0	0	324	448	206	344	373	339		252	81	66	81	66	65	0.030	5.13	0.92

### Wood Heater Test Data

Run: 2

Manufacturer: GHP Group  
 Model: PH1800WS  
 Tracking No.: 2402  
 Project No.: 0418WS017E  
 Test Date: 30-Jan-20  
 Beginning Clock Time: 12:26  
 Total Sampling Time: 420 min  
 Recording Interval: 5 min  
 Background Sample Volume: \_\_\_\_\_ cubic feet  
 Meter Box Y Factor: 0.992 (1) 0.989 (2) \_\_\_\_\_ (Amb)  
 Barometric Pressure: Begin Middle End Average  
29.52 29.52 29.52 0  
 OMNI Equipment Numbers: \_\_\_\_\_

PM Control Modules: 371, 372  
 Dilution Tunnel MW (dry): 29.00 lb/lb-mole  
 Dilution Tunnel MW (wet): 28.78 lb/lb-mole  
 Dilution Tunnel H<sub>2</sub>O: 2.00 percent  
 Dilution Tunnel Static: -0.278 "H<sub>2</sub>O  
 Tunnel Area: 0.19635 ft<sup>2</sup>  
 Pitot Tube Cp: 0.99  
 Avg. Tunnel Velocity: 19.80 ft/sec.  
 Initial Tunnel Flow: 227.1 scfm  
 Average Tunnel Flow: 218.1 scfm  
 Post-Test Leak Check (1): 0.000 cfm @ 6 in. Hg  
 Post-Test Leak Check (2): 0.000 cfm @ 8 in. Hg  
 Average Test Piece Fuel Moisture: 22.97 Dry Basis %

Technician Signature: 

Velocity Traverse Data									
	Pt.1	Pt.2	Pt.3	Pt.4	Pt.5	Pt.6	Pt.7	Pt.8	Center
Initial dP	0.080	0.096	0.102	0.088	0.080	0.100	0.100	0.080	0.106
Temp:	75	75	75	75	75	75	75	75	75
V <sub>strav</sub>	20.40				21.87			F <sub>p</sub> 0.933	


Elapsed Time (min)	Particulate Sampling Data												Fuel Weight (lb)		Temperature Data (°F)										Stack Gas Data							
	Gas Meter 1 (ft <sup>3</sup> )	Gas Meter 2 (ft <sup>3</sup> )	Sample Rate 1 (cfm)	Sample Rate 2 (cfm)	Orifice dH 1 ("H <sub>2</sub> O)	Meter 1 Temp (°F)	Meter 1 Vacuum ("Hg)	Orifice dH 2 ("H <sub>2</sub> O)	Meter 2 Temp (°F)	Meter 2 Vacuum ("Hg)	Dilution Tunnel (°F)	Dilution Tunnel Center dP	Pro. Rate 1	Pro. Rate 2	Scale Reading	Weight Change	Firebox Top	Firebox Bottom	Firebox Back	Firebox Left	Firebox Right	Avg. Stove Surface	Catalyst Exit	Stack	Filter 1	Dryer Exit 1	Filter 2	Dryer Exit 2	Ambient	Draft ("H <sub>2</sub> O)	CO <sub>2</sub> (%)	CO (%)
185	30.907	32.205	0.17	0.18	2.32	75	-3.37	1.80	72	-2.1	79	0.100	98	99	2.9	-0.1	317	445	202	341	369	335		249	81	66	81	66	65	0.029	5.12	0.86
190	31.741	33.082	0.17	0.18	2.32	75	-3.78	1.80	72	-1.9	79	0.100	98	99	2.8	-0.1	313	442	201	337	365	332		244	80	66	80	66	65	0.028	5.06	0.84
195	32.575	33.958	0.17	0.18	2.31	74	-3.67	1.80	72	-2	79	0.100	99	99	2.7	-0.1	307	441	199	334	362	329		243	81	66	81	66	66	0.027	5.03	0.89
200	33.409	34.834	0.17	0.18	2.31	74	-3.36	1.80	71	-1.9	78	0.100	98	99	2.6	-0.1	303	440	197	331	360	326		241	80	66	80	66	66	0.027	4.88	0.84
205	34.242	35.711	0.17	0.18	2.31	74	-3.37	1.80	71	-2	79	0.100	98	99	2.6	0	301	438	196	327	355	323		236	81	65	81	65	67	0.027	4.79	0.84
210	35.075	36.587	0.17	0.18	2.32	74	-3.67	1.80	71	-2.2	78	0.100	98	99	2.5	-0.1	297	436	196	324	353	321		234	80	65	80	65	67	0.026	4.75	0.82
215	35.908	37.462	0.17	0.18	2.30	73	-3.81	1.81	71	-2.1	80	0.100	99	99	2.4	-0.1	293	434	195	321	352	319		231	81	66	81	66	68	0.025	4.71	0.84
220	36.741	38.337	0.17	0.18	2.31	73	-3.39	1.80	71	-2.2	79	0.100	99	99	2.3	-0.1	290	432	194	318	351	317		229	82	66	82	66	69	0.025	4.61	0.83
225	37.573	39.213	0.17	0.18	2.30	73	-3.4	1.80	71	-1.9	79	0.100	99	99	2.2	-0.06	286	429	194	315	350	315		226	84	66	84	66	68	0.024	4.55	0.82
230	38.404	40.089	0.17	0.18	2.31	74	-3.57	1.79	71	-2.1	79	0.100	98	99	2.2	-0.04	282	426	192	312	349	312		224	84	66	84	66	68	0.024	4.48	0.79
235	39.236	40.964	0.17	0.18	2.30	74	-3.6	1.80	71	-2.1	80	0.100	98	99	2.1	-0.1	278	422	193	312	346	310		222	83	66	83	66	69	0.023	4.48	0.79
240	40.068	41.839	0.17	0.18	2.30	74	-3.83	1.81	71	-1.9	80	0.100	98	99	2.0	-0.1	275	418	190	311	342	307		219	84	67	84	67	69	0.023	4.52	0.78
245	40.900	42.716	0.17	0.18	2.31	74	-3.65	1.80	72	-2.1	80	0.100	98	99	1.9	-0.1	272	415	189	309	342	305		217	84	67	84	67	69	0.022	4.38	0.79
250	41.732	43.592	0.17	0.18	2.30	74	-3.78	1.81	72	-2.2	79	0.100	98	99	1.9	0	271	413	188	309	338	304		216	83	67	83	67	69	0.022	4.29	0.78
255	42.565	44.468	0.17	0.18	2.31	74	-3.82	1.81	72	-2.2	79	0.100	98	99	1.8	-0.1	267	411	186	308	338	302		214	83	67	83	67	69	0.022	4.2	0.74
260	43.398	45.345	0.17	0.18	2.30	74	-3.79	1.80	72	-2.2	79	0.100	98	99	1.7	-0.1	264	410	185	307	335	300		211	84	68	84	68	69	0.021	4.18	0.76
265	44.231	46.222	0.17	0.18	2.30	74	-3.83	1.81	72	-2.1	78	0.100	98	99	1.7	0	261	409	184	307	333	299		210	83	68	83	68	69	0.021	4.04	0.74
270	45.064	47.099	0.17	0.18	2.31	74	-3.56	1.81	72	-2.1	78	0.100	98	99	1.6	-0.1	259	407	183	305	330	297		207	83	68	83	68	70	0.020	3.95	0.75
275	45.897	47.977	0.17	0.18	2.32	74	-3.56	1.80	72	-2.2	78	0.100	98	99	1.5	-0.1	256	406	182	301	330	295		205	84	68	84	68	69	0.020	3.95	0.76
280	46.731	48.855	0.17	0.18	2.33	74	-3.84	1.80	72	-2.2	78	0.100	98	99	1.5	0	252	404	181	298	328	293		204	83	69	83	69	70	0.019	3.95	0.76
285	47.565	49.734	0.17	0.18	2.32	74	-3.69	1.81	72	-1.9	77	0.100	98	99	1.4	-0.1	249	402	182	294	326	291		201	83	69	83	69	69	0.019	3.92	0.76
290	48.399	50.612	0.17	0.18	2.33	74	-3.43	1.81	72	-2.2	77	0.090	104	104	1.3	-0.1	244	399	181	290	325	288		199	84	69	84	69	69	0.018	3.85	0.76
295	49.232	51.491	0.17	0.18	2.33	74	-3.47	1.81	72	-2	77	0.100	98	99	1.3	0	242	395	181	286	324	286		197	84	69	84	69	68	0.018	3.82	0.75
300	50.067	52.370	0.17	0.18	2.33	74	-3.47	1.81	72	-2.2	76	0.100	98	99	1.2	-0.1	241	390	182	284	323	284		196	83	69	83	69	68	0.017	3.81	0.75
305	50.901	53.250	0.17	0.18	2.32	74	-3.39	1.82	72	-2.2	76	0.100	98	99	1.1	-0.1	237	386	184	280	322	282		194	83	70	83	70	68	0.017	3.72	0.74
310	51.735	54.130	0.17	0.18	2.33	74	-3.84	1.82	72	-2.2	75	0.100	98	99	1.1	0	234	381	184	278	320	279		192	84	70	84	70	68	0.017	3.7	0.74
315	52.569	55.010	0.17	0.18	2.33	74	-3.54	1.83	72	-2.2	75	0.100	98	99	1.0	-0.1	233	377	183	276	318	277		191	83	70	83	70	68	0.017	3.69	0.76
320	53.404	55.891	0.17	0.18	2.32	74	-3.8	1.82	72	-2.1	75	0.100	98	99	1.0	0	231	373	185	272	317	276		189	83	70	83	70	68	0.016	3.51	0.73
325	54.238	56.771	0.17	0.18	2.31	74	-3.76	1.82	72	-1.9	75	0.100	98	99	0.9	-0.1	228	369	189	271	316	275		187	84	70	84	70	68	0.016	3.36	0.71
330	55.072	57.651	0.17	0.18	2.31	74	-3.79	1.82	72	-2.1	74	0.100	98	99	0.9	0	225	365	190	268	312	272		184	83	70	83	70	68	0.016	3.27	0.71
335	55.907	58.531	0.17	0.18	2.33	74	-3.58	1.82	72	-1.9	74	0.100	98	99	0.8	-0.1	223	362	189	267	310	270		183	82	70	82	70	67	0.015	3.24	0.71
340	56.741	59.411	0.17	0.18	2.33	74	-3.49	1.82	72	-1.9	74	0.100	98	99	0.8	0	220	358	186	264	306	267		181	83	70	83	70	67	0.015	3.04	0.67
345	57.574	60.292	0.17	0.18	2.33	74	-3.44	1.83	71	-2.1	73	0.100	98	99	0.7	-0.1	216	354	179	262	303	263		179	83	70	83	70	67	0.014	2.98	0.66
350	58.408	61.172	0.17	0.18	2.33	74	-3.59	1.82	71	-1.9	73	0.100	98	99	0.7	0	215	351	173	260	300	260		176	82	70	82	70	67	0.014	2.92	0.65
355	59.242	62.052	0.17	0.18	2.33	73	-3.37	1.81	71	-1.9	73	0.100	98	99	0.7	0	211	347	170	258	297	257		175	83	70	83	70	67	0.014	2.9	0.65
360	60.075	62.932	0.17	0.18	2.33	73	-3.44	1.82	71	-2.2	72	0.100	98	99	0.6	-0.1	208	344	167	255	295	254		172	84	70	84	70	67	0.013	2.91	0.65
365	60.908	63.813	0.17	0.18	2.32	73	-3.82	1.82	71	-2.2	72	0.100	98	99	0.6	0	206	341	166	253	293	252		171	82	70	82	70	66	0.013	2.93	0.65

### Wood Heater Test Data

Run: **2**

Manufacturer: GHP Group  
 Model: PH1800WS  
 Tracking No.: 2402  
 Project No.: 0418WS017E  
 Test Date: 30-Jan-20  
 Beginning Clock Time: 12:26  
 Total Sampling Time: 420 min  
 Recording Interval: 5 min  
 Background Sample Volume: \_\_\_\_\_ cubic feet  
 Meter Box Y Factor: 0.992 (1) 0.989 (2) \_\_\_\_\_ (Amb)  
 Barometric Pressure: Begin Middle End Average  
29.52 29.52 29.52 0  
 OMNI Equipment Numbers: \_\_\_\_\_

PM Control Modules: 371.372  
 Dilution Tunnel MW(dry): 29.00 lb/lb-mole  
 Dilution Tunnel MW(wet): 28.78 lb/lb-mole  
 Dilution Tunnel H2O: 2.00 percent  
 Dilution Tunnel Static: -0.278 "H2O  
 Tunnel Area: 0.19635 ft<sup>2</sup>  
 Pitot Tube Cp: 0.99  
 Avg. Tunnel Velocity: 19.80 ft/sec.  
 Initial Tunnel Flow: 227.1 scfm  
 Average Tunnel Flow: 218.1 scfm  
 Post-Test Leak Check (1): 0.000 cfm @ 6 in. Hg  
 Post-Test Leak Check (2): 0.000 cfm @ 8 in. Hg  
 Average Test Piece Fuel Moisture: 22.97 Dry Basis %

Technician Signature: 

Velocity Traverse Data									
	Pt.1	Pt.2	Pt.3	Pt.4	Pt.5	Pt.6	Pt.7	Pt.8	Center
Initial dP	0.080	0.096	0.102	0.088	0.080	0.100	0.100	0.080	0.106
Temp:	75	75	75	75	75	75	75	75	75
	V <sub>strav</sub> 20.40 ft/sec			V <sub>scnt</sub> 21.87 ft/sec			F <sub>p</sub> 0.933		

Elapsed Time (min)	Particulate Sampling Data														Fuel Weight (lb)		Temperature Data (°F)												Stack Gas Data			
	Gas Meter 1 (ft <sup>3</sup> )	Gas Meter 2 (ft <sup>3</sup> )	Sample Rate 1 (cfm)	Sample Rate 2 (cfm)	Orifice dH 1 ("H <sub>2</sub> O)	Meter 1 Temp (°F)	Meter 1 Vacuum ("Hg)	Orifice dH 2 ("H <sub>2</sub> O)	Meter 2 Temp (°F)	Meter 2 Vacuum ("Hg)	Dilution Tunnel (°F)	Dilution Tunnel Center dP	Pro. Rate 1	Pro. Rate 2	Scale Reading	Weight Change	Firebox Top	Firebox Bottom	Firebox Back	Firebox Left	Firebox Right	Avg. Stove Surface	Catalyst Exit	Stack	Filter 1	Dryer Exit 1	Filter 2	Dryer Exit 2	Ambient	Draft ("H <sub>2</sub> O)	CO <sub>2</sub> (%)	CO (%)
370	61.742	64.693	0.17	0.18	2.32	73	-3.74	1.83	71	-2.2	72	0.100	98	99	0.5	-0.1	204	338	164	250	291	249		170	82	70	82	70	66	0.012	2.9	0.64
375	62.576	65.573	0.17	0.18	2.32	73	-3.44	1.81	71	-2.2	72	0.100	98	99	0.5	0	203	335	164	247	290	248		168	83	69	83	69	66	0.012	2.87	0.64
380	63.409	66.454	0.17	0.18	2.32	73	-3.81	1.82	70	-2.1	72	0.100	98	99	0.4	-0.1	200	332	163	245	288	246		166	83	69	83	69	66	0.012	2.84	0.63
385	64.243	67.334	0.17	0.18	2.32	73	-3.65	1.81	70	-1.9	72	0.100	98	99	0.3	-0.08	197	329	162	242	285	243		169	82	69	82	69	65	0.011	1.89	0.41
390	65.076	68.214	0.17	0.18	2.31	73	-3.45	1.82	70	-2.2	71	0.100	98	99	0.3	-0.02	201	326	159	240	284	242		171	83	69	83	69	65	0.012	3.52	0.69
395	65.909	69.093	0.17	0.18	2.32	72	-3.66	1.82	70	-2.1	71	0.100	98	99	0.3	0	207	325	156	238	281	241		174	83	69	83	69	65	0.013	3.55	0.72
400	66.743	69.973	0.17	0.18	2.30	72	-3.68	1.83	70	-1.9	71	0.100	98	99	0.2	-0.1	212	324	154	236	279	241		176	82	69	82	69	66	0.014	3.49	0.72
405	67.576	70.852	0.17	0.18	2.33	72	-3.39	1.82	70	-2	71	0.100	98	99	0.2	0	215	325	153	234	276	241		177	82	69	82	69	65	0.014	3.35	0.75
410	68.408	71.731	0.17	0.18	2.32	72	-3.52	1.82	70	-1.9	71	0.100	98	99	0.1	-0.1	215	327	154	233	274	241		177	83	69	83	69	65	0.014	3.32	0.7
415	69.241	72.611	0.17	0.18	2.34	72	-3.36	1.83	70	-1.9	71	0.100	98	99	0.1	0	215	329	152	235	270	240		177	83	69	83	69	66	0.014	3.21	0.7
420	70.074	73.491	0.17	0.18	2.32	72	-3.75	1.83	69	-2.2	70	0.100	98	99	0.0	-0.1	213	330	151	234	266	239		177	82	69	82	69	65	0.014	3.03	0.66
Avg/Tot	70.074	73.491	0.17	0.17	2.30	75		1.79	73		86	0.098	100	100								264.8				65	83	66	68	0.032		

## Wood Heater Lab Data

Manufacturer: GHP Group                      Equipment Numbers: \_\_\_\_\_  
 Model: PH1800WS \_\_\_\_\_  
 Tracking No.: 2402 \_\_\_\_\_  
 Project No.: 0418WS017E \_\_\_\_\_  
 Run #: 2 \_\_\_\_\_  
 Date: 1/30/20 \_\_\_\_\_

**TRAIN 1 (First Hour emissions)**

Sample Component	Reagent	Filter, Probe or Dish #	Weights		
			Final, mg	Tare, mg	Particulate, mg
B. Front filter catch	Filter	T193S	97.0	88.0	9.0
C. Rear filter catch	Filter				0.0
D. Probe catch*	Probe				0.0
E. Filter seals catch*	Seals				0.0

**Sub-Total**    Total Particulate, mg:    9.0

**TRAIN 1 (Post First Hour Change-out)**

Sample Component	Reagent	Filter, Probe or Dish #	Weights		
			Final, mg	Tare, mg	Particulate, mg
B. Front filter catch	Filter	T189AP	176.5	173.9	2.6
C. Rear filter catch	Filter				0.0
D. Probe catch*	Probe	OES6	113712.2	113710.8	1.4
E. Filter seals catch*	Seals	R917	3288.7	3286.4	2.3

**Sub-Total**    Total Particulate, mg:    6.3

**Train 1 Aggregate**    Total Particulate, mg:    15.3

**TRAIN 2**

Sample Component	Reagent	Filter, Probe or Dish #	Weights		
			Final, mg	Tare, mg	Particulate, mg
A. Front filter catch	Filter	T189BP	186.7	175.6	11.1
B. Rear filter catch	Filter				0.0
C. Probe catch*	Probe	7	114982.3	114981.6	0.7
D. Filter seals catch*	Seals	R918	3493.3	3490.7	2.6

Total Particulate, mg:    14.4

**AMBIENT**

Sample Component	Reagent	Filter # or Probe #	Weights		
			Final, mg	Tare, mg	Particulate, mg
A. Front filter catch*	Filter				0.0

Total Particulate, mg:    0.0

\*Particulate catch that results in a negative number, is assumed to be zero for probes and seals, negative numbers for filters are assumed to be part of the seal weight.

Component	Equations:
A. Front filter catch	Final (mg) - Tare (mg) = Particulate, mg
B. Rear filter catch	Final (mg) - Tare (mg) = Particulate, mg
C. Probe catch	Final (mg) - Tare (mg) = Particulate, mg

Technician Signature: 

## Wood Heater Test Results


Manufacturer: GHP Group  
 Model: PH1800WS  
 Project No.: 0418WS017E  
 Tracking No.: 2402  
 Run: 2  
 Test Date: 01/30/20

Burn Rate	<b>1.10 kg/hr dry</b>
Average Tunnel Temperature	86 degrees Fahrenheit
Average Gas Velocity in Dilution Tunnel - vs	19.80 feet/second
Average Gas Flow Rate in Dilution Tunnel - Qsd	13088.0 dscf/hour
Average Delta p	0.098 inches H2O
Total Time of Test	420 minutes

	AMBIENT	SAMPLE TRAIN 1	SAMPLE TRAIN 2	FIRST HOUR FILTER (TRAIN 1)
Total Sample Volume - Vm	0.000 cubic feet	70.074 cubic feet	73.491 cubic feet	10.025 cubic feet
Average Gas Meter Temperature	68 degrees Fahrenheit	75 degrees Fahrenheit	73 degrees Fahrenheit	76 degrees Fahrenheit
Total Sample Volume (Standard Conditions) - Vmstd	0.000 dscf	68.021 dscf	71.381 dscf	9.717 dscf
Total Particulates - m <sub>T</sub>	0 mg	15.3 mg	14.4 mg	9 mg
Particulate Concentration (dry-standard) - C <sub>T</sub> /C <sub>s</sub>	0.000000 grams/dscf	0.00022 grams/dscf	0.00020 grams/dscf	0.00093 grams/dscf
Total Particulate Emissions - E <sub>T</sub>	0.00 grams	20.61 grams	18.48 grams	12.12 grams
Particulate Emission Rate	0.00 grams/hour	2.94 grams/hour	2.64 grams/hour	12.12 grams/hour
Emissions Factor		2.69 g/kg	2.41 g/kg	3.29 g/kg
Difference from Average Total Particulate Emissions		1.06 grams	1.06 grams	
<b>Dual Train Comparison Results Are Acceptable</b>				


FINAL AVERAGE RESULTS	
<b>Complete Test Run</b>	
Total Particulate Emissions - E <sub>T</sub>	19.54 grams
Particulate Emission Rate	<b>2.79 grams/hour</b>
Emissions Factor	2.55 grams/kg
<b>First Hour Emissions</b>	
Total Particulate Emissions - E <sub>T</sub>	12.12 grams
Particulate Emission Rate	12.12 grams/hour
Emissions Factor	3.29 grams/kg
7.5% of Average Total Particulate Emissions	1.47 grams

QUALITY CHECKS	
<b>Filter Temps &lt; 90 °F</b>	OK
<b>Filter Face Velocity (47 mm)</b>	OK
<b>Dryer Exit Temp &lt; 80F</b>	OK
<b>Leakage Rate</b>	OK
<b>Ambient Temp (55-90°F)</b>	OK
<b>Negative Probe Weight Eval.</b>	OK
<b>Pro-Rate Variation</b>	OK

Technician Signature: 

# Wood Heater Efficiency Results - CSA B415.1

**Manufacturer:** GHP Group  
**Model:** PH1800WS  
**Date:** 01/30/20  
**Run:** 2  
**Control #:** 0418WS017E  
**Test Duration:** 420  
**Output Category:** II

Technician Signature: 

**Test Results in Accordance with CSA B415.1-09**

	HHV Basis	LHV Basis
Overall Efficiency	70.6%	75.7%
Combustion Efficiency	93.9%	93.9%
Heat Transfer Efficiency	75%	80.6%

Output Rate (kJ/h)	14,978	14,208	(Btu/h)
Burn Rate (kg/h)	1.10	2.42	(lb/h)
Input (kJ/h)	21,203	20,113	(Btu/h)

Test Load Weight (dry kg)	7.67	16.91	dry lb
MC wet (%)	18.68155698		
MC dry (%)	22.97		
Particulate (g)	19.54		
CO (g)	671		
Test Duration (h)	7.00		

Emissions	Particulate	CO
g/MJ Output	0.19	6.40
g/kg Dry Fuel	2.55	87.50
g/h	2.79	95.93
lb/MM Btu Output	0.43	14.88

Air/Fuel Ratio (A/F)	15.57
----------------------	-------

VERSION:                      2.2                      12/14/2009



Values to be input manually

THIS DOCUMENT IS NOT AN ASTM STANDARD; IT IS UNDER CONSIDERATION WITHIN AN ASTM TECHNICAL COMMITTEE BUT HAS NOT RECEIVED ALL APPROVALS REQUIRED TO BECOME AN ASTM STANDARD. IT SHALL NOT BE REPRODUCED OR CIRCULATED OR QUOTED, IN WHOLE OR IN PART, OUTSIDE OF ASTM COMMITTEE ACTIVITIES EXCEPT WITH THE APPROVAL OF THE CHAIRMAN OF THE COMMITTEE HAVING JURISDICTION AND THE PRESIDENT OF THE SOCIETY. COPYRIGHT ASTM, 100 BARR HARBOR DRIVE, WEST CONSHOHOCKEN, PA 19428. ALL RIGHTS RESERVED.

**For Usable Firebox Volumes up to 3.0 ft<sup>3</sup> - Low and Medium Fire**

Nominal Required Load Density (wet basis)	12	lb/ft <sup>3</sup>		
Usable Firebox Volume	1.78	ft <sup>3</sup>		
Total Nom. Load Wt. Target	21.36	lb		
Total Load Wt. Allowable Range	20.29	to 22.43	lb	
Core Target Wt. Allowable Range	9.612	to 13.88	lb	
Remainder Load Wt. Allowable Range	7.48	to 11.75	lb	
				Mid-Point
Core Load Fuel Pc. Wt. Allowable Range	3.20	to 5.34	lb	4.27
Remainder Load Pc. Wt. Allowable Range	2.14	to 6.41	lb	4.27
	Pc. #			
Core Load Piece Wt. Actual	1	4.40	lb	In Range
	2	3.70	lb	In Range
	3	4.30	lb	In Range
Core Load Total. Wt. Actual		12.40	lb	In Range
	Pc. #			
Remainder Load Piece Wt.	1	5.70	lb	In Range
(2 or 3 Pcs.)	2	2.70	lb	In Range
	3		lb	NA
Remainder Load Piece Weight Ratio - Small/Large		47%		In Range ≤ 67%
Remainder Load Tot. Wt. Act		8.40	lb	In Range
Total Load Wt. Actual		20.80	lb	In Range
Core % of Total Wt.		60%		In Range 45-65%
Remainder % of Total Wt.		40%		In Range 35-55%
Actual Load % of Nominal Target		97%		In Range 95-105%
Actual Fuel Load Density		11.7	lb/ft <sup>3</sup>	
Allowable Charcoal Bed Wt. Range (lb)	2.1	to 4.1		Mid-Point
Actual Charcoal Bed Wt.		2.2	lb	In Range 3.1
Actual Fuel Load Ending Wt.		0.0	lb	Valid Test ≥ 90%
Total Wt. of Fuel Burned During Test Run lb.		20.8	lb	

Fuel Piece Moisture Reading (%-dry basis)

	1	2	3	Ave.		Pc. Wt. Dry Basis	
	24.8	24.4	22.1	23.8	In Range	3.56	1.61
	22.4	19.7	22.1	21.4	In Range	3.05	1.38
	24.1	26.6	23.2	24.6	In Range	3.45	1.56
	28	22.1	19.7	23.3	In Range	4.62	2.10
	28	19.6	17.8	21.8	In Range	2.22	1.01
				NA	NA	NA	NA
Total Load Ave. MC % (dry basis)				23.1	In Range		
Total Load Ave. MC % (wet basis)				18.8			
Total Test Load Weight (dry basis)						16.89	7.66
Total Fuel Weight Burned During Test Run (dry basis)						16.9	7.66

### Wood Heater Run Sheets

Client: GHP Group Project Number: 0418WS017E Run Number: 2  
 Model: PH1800WS Tracking Number: 2402 Date: 1/23/20  
 Test Crew: B. Davis  
 OMNI Equipment ID numbers: \_\_\_\_\_

#### Wood Heater Supplemental Data

Start Time: 1226 Booth #: N/A  
 Stop Time: 1926

**Stack Gas Leak Check:**

Initial: good Final: good

**Sample Train Leak Check:**

A: 0.0 @ 6 "Hg  
 B: 0.0 @ 8 "Hg

**Calibrations:** Span Gas CO<sub>2</sub>: 10.08 CO: 253

	Pre Test		Post Test	
	Zero	Span	Zero	Span
Time	<u>see Run 1 start</u>		<u>1936</u>	<u>1936</u>
CO <sub>2</sub>			<u>0.06</u>	<u>10.52</u>
CO			<u>0.01</u>	<u>2.79</u>

Air Velocity (ft/min): Initial: 250 Final: 250  
 Scale Audit (lbs): Initial: 10.0 Final: 10.0  
 Pitot Tube Leak Test: Initial: good Final: good  
 Stack Diameter (in): 6"  
 Induced Draft: 0.0  
 % Smoke Capture: 100%  
 Flue Pipe Cleaned Prior to First Test in Series:  
 Date: 1/23/20 Initials: BD

Tunnel Traverse		
Microtector Reading	dP (in H <sub>2</sub> O)	T(°F)
	<u>.080</u>	<u>75</u>
	<u>.096</u>	<u>75</u>
	<u>.102</u>	<u>75</u>
	<u>.088</u>	<u>75</u>
	<u>.080</u>	<u>75</u>
	<u>.100</u>	<u>75</u>
	<u>.100</u>	<u>75</u>
	<u>.080</u>	<u>75</u>
Center:		
	<u>.104</u>	<u>75</u>

	Initial	Middle	Ending
P <sub>b</sub> (in/Hg)	<u>29.52</u>		<u>29.52</u>
RH (%)	<u>50</u>		<u>47</u>
Ambient (°F)	<u>71</u>		<u>65</u>

**Background Filter Volume:** N/A

Tunnel Static Pressure (in H <sub>2</sub> O):	
Beginning of Test	End of Test
<u>- .278</u>	<u>- .278</u>

Technician Signature: B. Davis

Date: 2/4/2020

### Wood Heater Run Sheets

Client: GHP Group Project Number: 0418WS017E Run Number: 2  
 Model: PH1800WS Tracking Number: 2402 Date: 1/29/20  
 Test Crew: B. Davis  
 OMNI Equipment ID numbers: \_\_\_\_\_

#### Wood Heater Run Notes

##### Air Control Settings

Primary:

*Sully closed*

Secondary: fixed

Tertiary/Pilot: N/A

Fan: on High

##### Preburn Notes

Time	Notes
	<i>Tared 0.3 lbs from High burn total tare = <del>2.8</del> 2.1 lbs on</i>

##### Test Notes

Sketch test fuel configuration:

*See photo*

Start up procedures & Timeline:

Bypass: Not used  
 Fuel loaded by: by 45 seconds  
 Door closed at: 45 seconds  
 Primary air: Sully open until 11:45 min then set to full closed

Notes: FAN off until 30 min then turned to high

Time	Notes
<i>6 hrs 25 min</i>	<i>changed front sifter in run - A. Stirred coal bed. due to less than 1% of total load weight loss in 10 min</i>

Technician Signature: *B. Davis*

Date: 2/4/2020


**Run 3**  
**High Burn 1-minute data**  
**Non-Sampling High Burn**

### Wood Heater Test Data

Run: **3**

Manufacturer: GHP Group  
 Model: PH1800WS  
 Tracking No.: 2402  
 Project No.: 0418WS017E  
 Test Date: 30-Jan-20  
 Beginning Clock Time: 18:38  
 Total Sampling Time: 88 min  
 Recording Interval: 1 min  
 Background Sample Volume: \_\_\_\_\_ cubic feet  
 Meter Box Y Factor: 0.988 (1) 0.985 (2) \_\_\_\_\_ (Amb)  
 Barometric Pressure: Begin Middle End Average  
 \_\_\_\_\_  
 OMNI Equipment Numbers: \_\_\_\_\_

PM Control Modules: 371, 372  
 Dilution Tunnel MW(dry): 29.00 lb/lb-mole  
 Dilution Tunnel MW(wet): 28.78 lb/lb-mole  
 Dilution Tunnel H2O: 2.00 percent  
 Dilution Tunnel Static: \_\_\_\_\_ "H2O  
 Tunnel Area: 0.19635 ft<sup>2</sup>  
 Pitot Tube Cp: 0.99  
 Avg. Tunnel Velocity: #DIV/0! ft/sec.  
 Initial Tunnel Flow: #DIV/0! scfm  
 Average Tunnel Flow: #DIV/0! scfm  
 Post-Test Leak Check (1): \_\_\_\_\_ cfm @ \_\_\_\_\_ in. Hg  
 Post-Test Leak Check (2): \_\_\_\_\_ cfm @ \_\_\_\_\_ in. Hg  
 Average Test Piece Fuel Moisture: 24.58 Dry Basis %

Technician Signature: 

Velocity Traverse Data									
	Pt.1	Pt.2	Pt.3	Pt.4	Pt.5	Pt.6	Pt.7	Pt.8	Center
Initial dP									
Temp:									

V<sub>strav</sub> \_\_\_\_\_ ft/sec      V<sub>scent</sub> \_\_\_\_\_ ft/sec      F<sub>p</sub> \_\_\_\_\_


Elapsed Time (min)	Particulate Sampling Data														Fuel Weight (lb)		Temperature Data (°F)										Stack Gas Data					
	Gas Meter 1 (ft <sup>3</sup> )	Gas Meter 2 (ft <sup>3</sup> )	Sample Rate 1 (cfm)	Sample Rate 2 (cfm)	Orifice dH 1 ("H <sub>2</sub> O)	Meter 1 Temp (°F)	Meter 1 Vacuum ("Hg)	Orifice dH 2 ("H <sub>2</sub> O)	Meter 2 Temp (°F)	Meter 2 Vacuum ("Hg)	Dilution Tunnel (°F)	Dilution Tunnel Center dP	Pro. Rate 1	Pro. Rate 2	Scale Reading	Weight Change	Firebox Top	Firebox Bottom	Firebox Back	Firebox Left	Firebox Right	Avg. Stove Surface	Firebox	Stack	Filter 1	Dryer Exit 1	Filter 2	Dryer Exit 2	Ambient	Draft ("H <sub>2</sub> O)	CO <sub>2</sub> (%)	CO (%)
0															9.0		61	78	73	65	62	68		62					60	0.000		
1															9.0		62	77	73	65	62	68		138					60	0.001		
2															5.3		70	77	75	65	62	70		167					60	0.005		
3															8.7		110	77	78	65	63	79		248					60	0.013		
4															8.5		174	76	83	66	64	93		335					60	0.028		
5															8.2		258	76	81	68	66	110		408					60	0.042		
6															7.9		340	76	84	70	69	128		468					61	0.056		
7															7.6		411	76	88	72	73	144		512					61	0.064		
8															7.3		473	76	91	75	78	159		527					61	0.069		
9															7.0		518	77	94	79	84	170		548					61	0.072		
10															6.7		540	78	97	83	90	178		558					61	0.074		
11															6.4		558	81	101	87	96	185		574					62	0.075		
12															6.1		580	84	105	92	103	193		594					62	0.076		
13															5.8		601	87	109	98	111	201		611					62	0.077		
14															5.5		621	92	113	104	119	210		617					62	0.078		
15															5.2		639	97	117	111	129	219		619					62	0.079		
16															4.9		654	102	122	119	140	227		632					63	0.079		
17															4.6		662	109	128	128	152	236		637					63	0.080		
18															4.3		669	116	134	137	162	244		636					63	0.080		
19															4.0		674	124	140	147	173	252		639					64	0.080		
20															3.8		675	132	146	158	183	259		631					64	0.079		
21															3.5		672	142	153	170	193	266		624					64	0.079		
22															3.3		672	152	161	182	206	275		618					64	0.078		
23															3.1		671	163	168	195	221	284		610					64	0.077		
24															2.9		667	175	173	207	234	291		607					64	0.077		
25															2.7		667	186	179	220	248	300		608					64	0.076		
26															2.5		665	198	184	233	261	308		599					64	0.076		
27															2.3		661	211	189	246	273	316		591					65	0.075		
28															2.1		652	223	195	259	285	323		578					64	0.075		
29															2.0		642	235	200	271	297	329		568					65	0.073		
30															5.3		609	247	207	283	313	332		462					65	0.070		
31															17.5		592	260	209	294	320	335		533					65	0.067		
32															17.1		637	272	207	305	329	350		648					65	0.070		
33															16.7		700	284	202	314	338	368		719					66	0.075		
34															16.2		752	295	195	322	346	382		735					65	0.085		
35															15.9		786	306	189	327	352	392		742					66	0.088		
36															15.5		811	315	187	331	357	400		752					66	0.089		

### Wood Heater Test Data

Run: **3**

Manufacturer: GHP Group  
 Model: PH1800WS  
 Tracking No.: 2402  
 Project No.: 0418WS017E  
 Test Date: 30-Jan-20  
 Beginning Clock Time: 18:38  
 Total Sampling Time: 88 min  
 Recording Interval: 1 min  
 Background Sample Volume: \_\_\_\_\_ cubic feet  
 Meter Box Y Factor: 0.988 (1) 0.985 (2) \_\_\_\_\_ (Amb)  
 Barometric Pressure: Begin Middle End Average  
 \_\_\_\_\_  
 OMNI Equipment Numbers: \_\_\_\_\_

PM Control Modules: 371, 372  
 Dilution Tunnel MW(dry): 29.00 lb/lb-mole  
 Dilution Tunnel MW(wet): 28.78 lb/lb-mole  
 Dilution Tunnel H2O: 2.00 percent  
 Dilution Tunnel Static: \_\_\_\_\_ "H2O  
 Tunnel Area: 0.19635 ft<sup>2</sup>  
 Pitot Tube Cp: 0.99  
 Avg. Tunnel Velocity: #DIV/0! ft/sec.  
 Initial Tunnel Flow: #DIV/0! scfm  
 Average Tunnel Flow: #DIV/0! scfm  
 Post-Test Leak Check (1): \_\_\_\_\_ cfm @ \_\_\_\_\_ in. Hg  
 Post-Test Leak Check (2): \_\_\_\_\_ cfm @ \_\_\_\_\_ in. Hg  
 Average Test Piece Fuel Moisture: 24.58 Dry Basis %

Technician Signature: 

Velocity Traverse Data									
	Pt.1	Pt.2	Pt.3	Pt.4	Pt.5	Pt.6	Pt.7	Pt.8	Center
Initial dP									
Temp:									

V<sub>strav</sub> \_\_\_\_\_ ft/sec      V<sub>scent</sub> \_\_\_\_\_ ft/sec      F<sub>p</sub> \_\_\_\_\_


Elapsed Time (min)	Particulate Sampling Data												Fuel Weight (lb)		Temperature Data (°F)										Stack Gas Data								
	Gas Meter 1 (ft <sup>3</sup> )	Gas Meter 2 (ft <sup>3</sup> )	Sample Rate 1 (cfm)	Sample Rate 2 (cfm)	Orifice dH 1 ("H <sub>2</sub> O)	Meter 1 Temp (°F)	Meter 1 Vacuum ("Hg)	Orifice dH 2 ("H <sub>2</sub> O)	Meter 2 Temp (°F)	Meter 2 Vacuum ("Hg)	Dilution Tunnel (°F)	Dilution Tunnel Center dP	Pro. Rate 1	Pro. Rate 2	Scale Reading	Weight Change	Firebox Top	Firebox Bottom	Firebox Back	Firebox Left	Firebox Right	Avg. Stove Surface		Stack	Filter 1	Dryer Exit 1	Filter 2	Dryer Exit 2	Ambient	Draft ("H <sub>2</sub> O)	CO <sub>2</sub> (%)	CO (%)	
37															15.1		829	323	186	335	361	407			763					66	0.089		
38															14.7		841	330	185	337	366	412			770					66	0.090		
39															14.3		851	337	186	339	369	416			771					67	0.090		
40															13.9		859	343	187	341	374	421			769					66	0.090		
41															13.6		867	348	186	342	379	424			770					67	0.090		
42															13.2		870	353	187	344	384	428			770					67	0.089		
43															12.8		875	358	189	346	389	431			770					67	0.089		
44															12.5		878	363	189	347	395	434			770					67	0.089		
45															12.1		884	368	191	349	400	438			774					68	0.089		
46															11.7		884	372	194	351	406	441			771					68	0.089		
47															11.4		880	377	195	352	411	443			763					68	0.089		
48															11.1		875	381	198	355	417	445			758					68	0.089		
49															10.8		869	386	199	357	422	447			755					68	0.088		
50															10.4		863	390	199	359	427	448			751					68	0.087		
51															10.1		857	394	200	361	433	449			747					68	0.087		
52															9.8		854	399	204	364	439	452			747					68	0.087		
53															9.4		849	403	204	366	445	453			743					69	0.087		
54															9.1		848	407	209	370	450	457			741					68	0.087		
55															8.9		846	412	213	373	455	460			737					70	0.086		
56															8.6		841	416	216	378	459	462			736					69	0.086		
57															8.2		841	420	220	381	463	465			733					69	0.086		
58															8.0		838	424	225	385	468	468			730					69	0.086		
59															7.7		838	428	228	389	472	471			723					70	0.085		
60															7.4		834	432	233	393	476	474			720					69	0.085		
61															7.1		828	437	238	396	480	476			716					70	0.084		
62															6.8		825	441	243	399	484	478			710					70	0.084		
63															6.6		818	445	246	402	490	480			703					70	0.083		
64															6.3		813	449	250	404	493	482			699					70	0.083		
65															6.1		812	453	255	408	497	485			697					69	0.083		
66															5.9		804	457	262	413	501	487			693					71	0.082		
67															5.5		801	461	265	415	505	489			690					70	0.082		
68															5.3		795	465	271	418	507	491			683					70	0.081		
69															5.1		787	469	275	423	511	493			677					71	0.081		
70															4.9		782	474	278	427	516	495			673					71	0.080		
71															4.7		777	478	282	432	518	497			669					70	0.080		
72															4.4		770	482	285	435	521	499			667					71	0.080		
73															4.3		765	486	288	440	524	501			664					71	0.079		

### Wood Heater Test Data

Run: **3**

Manufacturer: GHP Group  
 Model: PH1800WS  
 Tracking No.: 2402  
 Project No.: 0418WS017E  
 Test Date: 30-Jan-20  
 Beginning Clock Time: 18:38  
 Total Sampling Time: 88 min  
 Recording Interval: 1 min  
 Background Sample Volume: \_\_\_\_\_ cubic feet  
 Meter Box Y Factor: 0.988 (1) 0.985 (2) \_\_\_\_\_ (Amb)  
 Barometric Pressure: Begin Middle End Average  
 \_\_\_\_\_  
 0  
 OMNI Equipment Numbers: \_\_\_\_\_

PM Control Modules: 371, 372  
 Dilution Tunnel MW (dry): 29.00 lb/lb-mole  
 Dilution Tunnel MW (wet): 28.78 lb/lb-mole  
 Dilution Tunnel H2O: 2.00 percent  
 Dilution Tunnel Static: \_\_\_\_\_ "H2O  
 Tunnel Area: 0.19635 ft<sup>2</sup>  
 Pitot Tube Cp: 0.99  
 Avg. Tunnel Velocity: #DIV/0! ft/sec.  
 Initial Tunnel Flow: #DIV/0! scfm  
 Average Tunnel Flow: #DIV/0! scfm  
 Post-Test Leak Check (1): \_\_\_\_\_ cfm @ \_\_\_\_\_ in. Hg  
 Post-Test Leak Check (2): \_\_\_\_\_ cfm @ \_\_\_\_\_ in. Hg  
 Average Test Piece Fuel Moisture: 24.58 Dry Basis %

Technician Signature: 

Velocity Traverse Data									
	Pt.1	Pt.2	Pt.3	Pt.4	Pt.5	Pt.6	Pt.7	Pt.8	Center
Initial dP									
Temp:									

V<sub>strav</sub> \_\_\_\_\_ ft/sec      V<sub>scent</sub> \_\_\_\_\_ ft/sec      F<sub>p</sub> \_\_\_\_\_

Elapsed Time (min)	Particulate Sampling Data														Fuel Weight (lb)		Temperature Data (°F)										Stack Gas Data						
	Gas Meter 1 (ft <sup>3</sup> )	Gas Meter 2 (ft <sup>3</sup> )	Sample Rate 1 (cfm)	Sample Rate 2 (cfm)	Orifice dH 1 ("H <sub>2</sub> O)	Meter 1 Temp (°F)	Meter 1 Vacuum ("Hg)	Orifice dH 2 ("H <sub>2</sub> O)	Meter 2 Temp (°F)	Meter 2 Vacuum ("Hg)	Dilution Tunnel (°F)	Dilution Tunnel Center dP	Pro. Rate 1	Pro. Rate 2	Scale Reading	Weight Change	Firebox Top	Firebox Bottom	Firebox Back	Firebox Left	Firebox Right	Avg. Stove Surface		Stack	Filter 1	Dryer Exit 1	Filter 2	Dryer Exit 2	Ambient	Draft ("H <sub>2</sub> O)	CO <sub>2</sub> (%)	CO (%)	
74															4.0		760	490	293	445	528	503		663					70	0.079			
75															3.8		754	494	299	449	530	505		658					71	0.079			
76															3.6		752	499	301	453	532	507		653					70	0.079			
77															3.5		745	503	309	459	536	510		646					70	0.079			
78															3.3		739	507	315	464	538	513		642					71	0.078			
79															3.1		734	512	321	470	542	516		638					70	0.077			
80															2.9		730	516	326	476	545	519		636					71	0.077			
81															2.8		725	520	330	480	548	521		629					72	0.077			
82															2.6		720	524	336	486	550	523		630					72	0.076			
83															2.4		719	528	339	492	551	526		627					71	0.076			
84															2.3		715	532	343	497	556	529		618					72	0.076			
85															2.1		707	536	343	501	559	529		611					72	0.075			
86															2.1		698	540	347	505	561	530		603					72	0.074			
87															1.9		691	545	351	507	565	532		595					72	0.073			
88															1.8		683	548	350	510	567	532		587					71	0.072			
Avg/Tot	0.000	0.000	#DIV/0!	#DIV/0!	#DIV/0!	#DIV/0!		#DIV/0!	#DIV/0!		#DIV/0!	#DIV/0!	#DIV/0!	#DIV/0!																			

## Wood Heater Test Results

Manufacturer: GHP Group  
 Model: PH1800WS  
 Project No.: 0418WS017E  
 Tracking No.: 2402  
 Run: 3  
 Test Date: 01/30/20

Burn Rate	<b>5.95 kg/hr dry</b>
Total Time of Test	58 minutes

	AMBIENT	SAMPLE TRAIN 1	SAMPLE TRAIN 2	FIRST HOUR FILTER (TRAIN 1)
<b>#DIV/0!</b>				

	FINAL AVERAGE RESULTS
<b>Complete Test Run</b>	
Total Particulate Emissions - E <sub>T</sub>	
Particulate Emission Rate	
Emissions Factor	
<b>First Hour Emissions</b>	
Total Particulate Emissions - E <sub>T</sub>	
Particulate Emission Rate	
Emissions Factor	
7.5% of Average Total Particulate Emissions	

	QUALITY CHECKS
<b>Ambient Temp (55-90°F)</b>	OK

Technician Signature: 



Adjunct to ASTM E XXXX Wood Heater Cordwood Test Method - May 10, 2017 Version  
 Cordwood Fuel Load Calculators - 10 lb/ft<sup>3</sup> Nominal Load Density  
 Core 45-65% of Total Load Weight, Remainder 35-55% of Total Load Weight  
 Values to be input manually

THIS DOCUMENT IS NOT AN ASTM STANDARD; IT IS UNDER CONSIDERATION WITHIN AN ASTM TECHNICAL COMMITTEE BUT HAS NOT RECEIVED ALL APPROVALS REQUIRED TO BECOME AN ASTM STANDARD. IT SHALL NOT BE REPRODUCED OR CIRCULATED OR QUOTED, IN WHOLE OR IN PART, OUTSIDE OF ASTM COMMITTEE ACTIVITIES EXCEPT WITH THE APPROVAL OF THE CHAIRMAN OF THE COMMITTEE HAVING JURISDICTION AND THE PRESIDENT OF THE SOCIETY. COPYRIGHT ASTM, 100 BARR HARBOR DRIVE, WEST CONSHOHOCKEN, PA 19428. ALL RIGHTS RESERVED.

For All Usable Firebox Volumes - High Fire Test Only				
Nominal Required Load Density (wet basis)	10	lb/ft <sup>3</sup>		
Usable Firebox Volume	1.78	ft <sup>3</sup>		
Total Nom. Load Wt. Target	17.80	lb		
Total Load Wt. Allowable Range	16.90	to 18.70	lb	
Core Target Wt. Allowable Range	8.00	to 11.60	lb	
Remainder Load Wt. Allowable Range	6.20	to 9.80	lb	
				Mid-Point
Core Load Pc. Wt. Allowable Range	2.70	to 4.50	lb	3.60
Remainder Load Pc. Wt. Allowable Range	1.80	to 9.80	lb	5.80
	Pc. #			
Core Load Piece Wt. Actual	1	4.20	lb	In Range
	2	3.20	lb	In Range
	3	3.10	lb	In Range
Core Load Total. Wt. Actual		10.50	lb	In Range
	Pc. #			
Remainder Load Piece Wt.	1	4.80	lb	In Range
(1 to 3 Pcs.)	2	2.70	lb	In Range
	3		lb	NA
Remainder Load Tot. Wt. Act		7.50	lb	In Range
Total Load Wt. Actual		18.00	lb	In Range
Core % of Total Wt.		58%		In Range 45-65%
Remainder % of Total Wt.		42%		In Range 35-55%
Actual Load % of Nominal Target		101%		In Range 95-105%
Actual Fuel Load Density		10.1	lb/ft <sup>3</sup>	
<u>Kindling and Start-up Fuel</u>				
Maximum Kindling Wt. (20% of Tot. Load Wt.)		3.60	lb	
Actual Kindling Wt.		3.60	lb	In Range 20.0%
Maximum Start-up Fuel Wt. (30% of Tot. Load Wt.)		5.40	lb	
Actual Start-up Fuel Wt.		5.40	lb	In Range 30.0%
Allowable Residual Start-up Fuel Wt. Range	1.8	to 3.6	lb	Mid-Point
Actual Residual Start-up Fuel Wt.		1.9	lb	In Range 2.7
Total Wt. All Fuel Added (wet basis)		27.00	lb	
<u>High Fire Test Run End Point Range</u>				
	Low		High	Mid-Point
Based on Fuel Load Wt. (w/tares)	1.6	to	2.0	lb 1.8
Actual Fuel Load Ending Wt.		1.8	lb	In Range

Fuel Piece Moisture Reading (%-dry basis)						
1	2	3	Ave.		Pc. Wt. Dry Basis	
24.1	22.5	19.3	22.0	In Range	3.44	1.56
28	28	25.8	27.3	In Range	2.51	1.14
27.6	27.7	26.1	27.1	In Range	2.44	1.11
23	23.6	21.6	22.7	In Range	3.91	1.77
23.1	24.6	23.7	23.8	In Range	2.18	0.99
			NA	NA	NA	NA
Total Load Ave. MC (%-dry basis)			24.2	In Range		
Total Load Ave. MC % (wet basis)			19.5			
Total Test Load Weight (dry basis)					14.49	6.57
<u>Kindling Moisture (%-dry basis)</u>						
9.6	10.2	12	10.6	In Range	3.25	1.48
<u>Start-up Fuel Moisture Readings (%-dry basis)</u>						
23.3	19.3	23.9	22.2	In Range	4.42	2.00
Total Wt. All Fuel Added (dry basis)					22.16	10.05
Total Wt. All Fuel Burned (dry basis)					18.5	8.4

### Wood Heater Run Sheets

Client: GHP Group Project Number: 0418WS017E Run Number: 3  
 Model: PH1800WS Tracking Number: 2402 Date: 1/30/20  
 Test Crew: B Daws  
 OMNI Equipment ID numbers: \_\_\_\_\_

#### Wood Heater Run Notes

##### Air Control Settings

Primary:

3/16" from full closed

Secondary: fixed

Tertiary/Pilot: W/A

Fan: On High

##### Preburn Notes

Time	Notes
<u>Ø</u>	<u>Bypass open, door open, torch used for 1 min then door to 12" open. Door closed @ 2:30, bypass closed @ 2:30. Fan on High @ 5:00 min.</u>

##### Test Notes

Sketch test fuel configuration:

See photo

Start up procedures & Timeline:

Bypass: Not used  
 Fuel loaded by: 70 seconds  
 Door closed at: 75 seconds  
 Primary air: fully open until 11 min (18 lbs)

Notes: Fan off until on High achieve Test

Time	Notes
<del>60</del>	<del>changed fuel filter in tank. A. W/A</del>

Technician Signature: B Daws

Date: 2/4/2020

### Wood Heater Run Sheets

Client: GHP Group Project Number: 0418WS017E Run Number: 3  
 Model: PH1800WS Tracking Number: 2402 Date: 1/30/20  
 Test Crew: B. Davis  
 OMNI Equipment ID numbers: \_\_\_\_\_

#### Wood Heater Supplemental Data

Start Time: 0938 Booth #: \_\_\_\_\_

Stop Time: 1106

**Stack Gas Leak Check:**

Initial: N/A Final: \_\_\_\_\_

**Sample Train Leak Check:**

A: N/A @ \_\_\_\_\_ "Hg  
 B: N/A @ \_\_\_\_\_ "Hg

**Calibrations:** Span Gas CO<sub>2</sub>: \_\_\_\_\_ CO: \_\_\_\_\_

	Pre Test		Post Test	
	Zero	Span	Zero	Span
Time	<u>N/A</u>			
CO <sub>2</sub>				
CO				

Air Velocity (ft/min): Initial: 250 Final: 250

Scale Audit (lbs): Initial: 10.0 Final: 10.0

Pitot Tube Leak Test: Initial: good Final: good

Stack Diameter (in): 6"

Induced Draft: 0.0

% Smoke Capture: N/A

Flue Pipe Cleaned Prior to First Test in Series:

Date: \_\_\_\_\_ Initials: \_\_\_\_\_

	Initial	Middle	Ending
P <sub>b</sub> (in/Hg)	<u>29.63</u>		<u>29.63</u>
RH (%)	<u>47</u>		<u>45</u>
Ambient (°F)	<u>60</u>		<u>71</u>

Tunnel Traverse		
Microtector Reading	dP (in H <sub>2</sub> O)	T(°F)
<u>N/A</u>		
Center:		

**Background Filter Volume:** N/A

Tunnel Static Pressure (in H <sub>2</sub> O):	
Beginning of Test	End of Test
<u>N/A</u>	

Technician Signature: B. Davis

Date: 2/4/2020


**Run 4**  
**Medium Burn**

### Wood Heater Test Data

Run: **4**

Manufacturer: GHP Group  
 Model: PH1800WS  
 Tracking No.: 2402  
 Project No.: 0418WS017E  
 Test Date: 30-Jan-20  
 Beginning Clock Time: 11:29  
 Total Sampling Time: 350 min  
 Recording Interval: 5 min  
 Background Sample Volume: \_\_\_\_\_ cubic feet  
 Meter Box Y Factor: 0.988 (1) 0.985 (2) \_\_\_\_\_ (Amb)  
 Barometric Pressure: Begin Middle End Average  
29.63 29.54 29.59 0  
 OMNI Equipment Numbers: \_\_\_\_\_

PM Control Modules: 371, 372  
 Dilution Tunnel MW(dry): 29.00 lb/lb-mole  
 Dilution Tunnel MW(wet): 28.78 lb/lb-mole  
 Dilution Tunnel H2O: 2.00 percent  
 Dilution Tunnel Static: -0.278 "H2O  
 Tunnel Area: 0.19635 ft<sup>2</sup>  
 Pitot Tube Cp: 0.99  
 Avg. Tunnel Velocity: 19.82 ft/sec.  
 Initial Tunnel Flow: 224.0 scfm  
 Average Tunnel Flow: 215.4 scfm  
 Post-Test Leak Check (1): 0.000 cfm @ 8 in. Hg  
 Post-Test Leak Check (2): 0.000 cfm @ 6 in. Hg  
 Average Test Piece Fuel Moisture: 21.27 Dry Basis %

Technician Signature: 

Velocity Traverse Data									
	Pt.1	Pt.2	Pt.3	Pt.4	Pt.5	Pt.6	Pt.7	Pt.8	Center
Initial dP	0.080	0.096	0.102	0.086	0.074	0.092	0.096	0.084	0.106
Temp:	79	79	79	79	79	79	79	79	79
V <sub>strav</sub>	20.24			ft/sec			V <sub>scnt</sub>	21.91	
							ft/sec	F <sub>p</sub>	0.923

Elapsed Time (min)	Particulate Sampling Data												Fuel Weight (lb)		Temperature Data (°F)										Stack Gas Data							
	Gas Meter 1 (ft <sup>3</sup> )	Gas Meter 2 (ft <sup>3</sup> )	Sample Rate 1 (cfm)	Sample Rate 2 (cfm)	Orifice dH 1 ("H <sub>2</sub> O)	Meter 1 Temp (°F)	Meter 1 Vacuum ("Hg)	Orifice dH 2 ("H <sub>2</sub> O)	Meter 2 Temp (°F)	Meter 2 Vacuum ("Hg)	Dilution Tunnel (°F)	Dilution Tunnel Center dP	Pro. Rate 1	Pro. Rate 2	Scale Reading	Weight Change	Firebox Top	Firebox Bottom	Firebox Back	Firebox Left	Firebox Right	Avg. Stove Surface	Stack	Filter 1	Dryer Exit 1	Filter 2	Dryer Exit 2	Ambient	Draft ("H <sub>2</sub> O)	CO <sub>2</sub> (%)	CO (%)	
0	0.000	0.000			1.39	74	-2.87	1.70	72	-0.8	114	0.090			21.0		452	588	432	499	531	500		403	82	66	90	67	72	0.050	3.56	0.3
5	0.816	0.859	0.16	0.17	2.30	75	-3.57	1.76	72	-1.9	133	0.090	107	106	20.2	-0.82	512	586	469	483	511	512		536	86	65	85	64	72	0.063	9.54	0.2
10	1.637	1.713	0.16	0.17	2.28	75	-4.14	1.73	73	-2	168	0.090	111	109	18.4	-1.78	761	580	449	455	492	547		733	89	65	86	65	72	0.085	16.07	0.64
15	2.459	2.570	0.16	0.17	2.27	76	-4.01	1.81	73	-1.8	135	0.090	108	106	17.1	-1.3	772	571	432	432	486	539		604	86	66	86	66	73	0.077	12.81	0.18
20	3.281	3.440	0.16	0.17	2.26	76	-3.7	1.79	74	-1.8	127	0.090	107	107	16.1	-1	711	560	418	420	480	518		551	88	67	87	68	73	0.072	11.28	0.25
25	4.102	4.304	0.16	0.17	2.25	77	-3.59	1.73	74	-2.2	123	0.090	106	106	15.1	-1	681	551	406	412	474	505		530	90	68	87	70	74	0.069	10.78	0.33
30	4.921	5.164	0.16	0.17	2.23	77	-3.73	1.75	74	-1.9	120	0.100	100	100	14.4	-0.74	652	541	395	404	465	491		506	89	69	88	71	75	0.067	9.78	0.45
35	5.742	6.031	0.16	0.17	2.25	78	-3.68	1.80	75	-2	115	0.090	105	105	13.6	-0.76	615	531	222	397	459	445		472	88	70	88	73	75	0.063	8.75	0.6
40	6.560	6.902	0.16	0.17	2.22	78	-4.11	1.79	75	-2.2	112	0.100	99	100	12.8	-0.8	576	521	206	390	453	429		448	88	71	88	74	75	0.060	8.01	0.62
45	7.382	7.774	0.16	0.17	2.27	78	-4	1.80	76	-1.9	109	0.100	99	100	12.2	-0.6	550	512	196	383	445	417		430	87	72	88	75	74	0.058	7.87	0.7
50	8.208	8.645	0.17	0.17	2.24	79	-4.31	1.77	76	-2.3	107	0.090	105	105	11.6	-0.6	532	504	190	373	439	408		417	87	73	88	76	75	0.056	7.73	0.69
55	9.036	9.515	0.17	0.17	2.29	79	-3.99	1.78	77	-2.2	106	0.100	100	99	10.9	-0.7	520	497	187	364	434	400		409	87	72	88	76	75	0.055	7.74	0.68
60	9.871	10.387	0.17	0.17	2.31	79	-3.84	1.78	77	-2	106	0.090	106	105	10.3	-0.6	512	491	186	358	431	396		405	87	67	87	71	74	0.055	7.88	0.64
65	10.713	11.262	0.17	0.18	2.32	80	-3.81	1.80	77	-2.1	105	0.100	101	99	9.8	-0.5	511	486	186	353	426	392		407	87	62	87	69	75	0.055	8.14	0.51
70	11.550	12.139	0.17	0.18	2.34	80	-4.04	1.81	77	-2.2	105	0.100	101	100	9.1	-0.68	513	481	185	350	425	391		408	88	59	87	67	74	0.055	8.32	0.45
75	12.389	13.017	0.17	0.18	2.33	80	-3.94	1.81	77	-2.2	105	0.100	101	100	8.6	-0.52	516	478	188	349	423	391		412	87	57	87	65	74	0.055	8.53	0.4
80	13.230	13.898	0.17	0.18	2.29	80	-3.54	1.83	78	-2	105	0.100	101	100	8.0	-0.6	523	476	192	349	422	392		417	87	56	87	63	75	0.056	8.8	0.27
85	14.060	14.782	0.17	0.18	2.28	80	-3.65	1.83	78	-2	105	0.100	100	100	7.5	-0.5	529	474	196	352	420	394		423	87	54	87	61	74	0.055	9.15	0.22
90	14.892	15.667	0.17	0.18	2.29	81	-3.45	1.84	78	-1.9	106	0.100	100	100	6.9	-0.6	541	474	201	354	418	398		431	87	54	87	60	75	0.056	9.41	0.13
95	15.724	16.555	0.17	0.18	2.29	81	-3.66	1.84	78	-2.2	106	0.100	100	101	6.3	-0.6	544	472	209	357	420	400		423	87	53	87	59	75	0.056	8.73	0.25
100	16.557	17.444	0.17	0.18	2.29	81	-3.46	1.85	78	-1.9	105	0.100	100	101	5.9	-0.4	533	470	213	360	423	400		413	87	52	87	59	75	0.055	7.93	0.31
105	17.389	18.333	0.17	0.18	2.30	81	-3.67	1.85	78	-1.9	104	0.100	100	101	5.5	-0.4	526	470	219	364	423	400		406	87	52	87	58	76	0.054	7.99	0.26
110	18.223	19.225	0.17	0.18	2.30	81	-3.7	1.86	78	-1.9	104	0.100	100	101	5.1	-0.4	520	471	224	366	423	401		401	87	52	87	58	75	0.053	7.95	0.21
115	19.056	20.115	0.17	0.18	2.28	81	-3.78	1.85	78	-2	103	0.100	100	101	4.7	-0.4	517	473	226	366	423	401		395	87	52	86	58	76	0.052	7.75	0.25
120	19.890	21.007	0.17	0.18	2.28	81	-3.69	1.85	78	-2	101	0.100	100	101	4.3	-0.4	507	473	227	367	423	399		388	87	52	86	57	75	0.052	7.48	0.24
125	20.723	21.897	0.17	0.18	2.31	81	-3.64	1.86	78	-2.1	100	0.100	99	101	4.0	-0.3	491	473	229	368	423	397		379	87	52	86	57	75	0.050	6.99	0.3
130	21.556	22.788	0.17	0.18	2.31	81	-3.68	1.85	78	-2	100	0.100	99	101	3.7	-0.3	480	473	230	365	421	394		373	86	52	86	57	75	0.049	6.9	0.3
135	22.390	23.678	0.17	0.18	2.30	81	-3.51	1.84	79	-1.9	99	0.100	100	100	3.4	-0.3	465	474	232	365	418	391		360	87	52	86	57	76	0.047	6.4	0.32
140	23.224	24.569	0.17	0.18	2.30	81	-3.66	1.85	79	-2.1	97	0.100	99	100	3.2	-0.2	448	474	233	364	414	387		347	86	52	86	57	75	0.045	5.86	0.34
145	24.059	25.460	0.17	0.18	2.30	81	-3.65	1.86	79	-2.1	95	0.100	99	100	3.1	-0.1	424	474	233	365	410	381		327	86	52	85	57	74	0.042	5.05	0.53
150	24.894	26.352	0.17	0.18	2.30	81	-3.87	1.86	79	-2.1	93	0.100	99	100	2.9	-0.2	396	473	235	363	403	374		309	85	52	85	57	73	0.039	4.74	0.66
155	25.730	27.244	0.17	0.18	2.29	81	-3.45	1.86	78	-1.9	91	0.100	99	100	2.8	-0.1	376	472	236	359	398	368		296	85	52	85	57	73	0.036	4.65	0.67
160	26.565	28.135	0.17	0.18	2.31	81	-3.82	1.87	78	-2.1	91	0.100	99	100	2.7	-0.1	361	469	237	354	392	363		287	85	53	84	57	74	0.036	4.6	0.66
165	27.401	29.021	0.17	0.18	2.31	81	-3.41	1.83	78	-1.8	89	0.100	99	99	2.6	-0.1	349	466	234	351	388	358		281	84	53	84	57	73	0.034	4.54	0.68
170	28.235	29.904	0.17	0.18	2.32	81	-3.83	1.83	78	-1.8	88	0.100	99	99	2.5	-0.1	343	462	231	346	381	353		275	85	53	84	57	73	0.033	4.34	0.67
175	29.070	30.787	0.17	0.18	2.31	81	-3.42	1.82	78	-2	88	0.100	99	99	2.4	-0.1	336	458	224	341	378	347		270	84	54	83	58	73	0.032	4.17	0.67
180	29.905	31.670	0.17	0.18	2.31	80	-3.61	1.82	78	-2.1	88	0.100	99	99	2.4	0	327	454	220	335	374	342		264	84	54	83	58	73	0.031	4.1	0.65

### Wood Heater Test Data

Run: **4**

Manufacturer: GHP Group  
 Model: PH1800WS  
 Tracking No.: 2402  
 Project No.: 0418WS017E  
 Test Date: 30-Jan-20  
 Beginning Clock Time: 11:29

Total Sampling Time: 350 min  
 Recording Interval: 5 min  
 Background Sample Volume: \_\_\_\_\_ cubic feet

Meter Box Y Factor: 0.988 (1) 0.985 (2) \_\_\_\_\_ (Amb)

Barometric Pressure: Begin Middle End Average  
29.63 29.54 29.59 0

OMNI Equipment Numbers: \_\_\_\_\_

PM Control Modules: 371, 372  
 Dilution Tunnel MW (dry): 29.00 lb/lb-mole  
 Dilution Tunnel MW (wet): 28.78 lb/lb-mole  
 Dilution Tunnel H2O: 2.00 percent  
 Dilution Tunnel Static: -0.278 "H2O  
 Tunnel Area: 0.19635 ft<sup>2</sup>  
 Pitot Tube Cp: 0.99

Avg. Tunnel Velocity: 19.82 ft/sec.  
 Initial Tunnel Flow: 224.0 scfm  
 Average Tunnel Flow: 215.4 scfm  
 Post-Test Leak Check (1): 0.000 cfm @ 8 in. Hg  
 Post-Test Leak Check (2): 0.000 cfm @ 6 in. Hg  
 Average Test Piece Fuel Moisture: 21.27 Dry Basis %

Technician Signature: 

Velocity Traverse Data									
	Pt.1	Pt.2	Pt.3	Pt.4	Pt.5	Pt.6	Pt.7	Pt.8	Center
Initial dP	0.080	0.096	0.102	0.086	0.074	0.092	0.096	0.084	0.106
Temp:	79	79	79	79	79	79	79	79	79
V <sub>strav</sub>	20.24			ft/sec			V <sub>scnt</sub>	21.91	
							ft/sec	F <sub>p</sub>	0.923

Elapsed Time (min)	Particulate Sampling Data												Fuel Weight (lb)		Temperature Data (°F)										Stack Gas Data						
	Gas Meter 1 (ft <sup>3</sup> )	Gas Meter 2 (ft <sup>3</sup> )	Sample Rate 1 (cfm)	Sample Rate 2 (cfm)	Orifice dH 1 ("H <sub>2</sub> O)	Meter 1 Temp (°F)	Meter 1 Vacuum ("Hg)	Orifice dH 2 ("H <sub>2</sub> O)	Meter 2 Temp (°F)	Meter 2 Vacuum ("Hg)	Dilution Tunnel (°F)	Dilution Tunnel Center dP	Pro. Rate 1	Pro. Rate 2	Scale Reading	Weight Change	Firebox Top	Firebox Bottom	Firebox Back	Firebox Left	Firebox Right	Avg. Stove Surface	Stack	Filter 1	Dryer Exit 1	Filter 2	Dryer Exit 2	Ambient	Draft ("H <sub>2</sub> O)	CO <sub>2</sub> (%)	CO (%)
185	30.740	32.553	0.17	0.18	2.30	80	-3.7	1.82	78	-1.9	87	0.100	99	99	2.3	-0.1	319	450	217	330	371	337	260	84	55	83	58	71	0.030	3.99	0.66
190	31.575	33.436	0.17	0.18	2.30	80	-3.84	1.82	77	-2.1	85	0.100	99	99	2.2	-0.1	311	446	215	328	368	334	255	84	55	83	59	72	0.029	3.88	0.65
195	32.411	34.319	0.17	0.18	2.30	80	-3.5	1.82	77	-1.8	85	0.100	99	99	2.1	-0.1	304	441	213	324	363	329	250	83	55	82	59	71	0.028	3.69	0.64
200	33.245	35.203	0.17	0.18	2.31	80	-3.86	1.82	77	-1.9	84	0.100	98	99	2.0	-0.1	299	436	211	319	360	325	246	83	56	82	60	72	0.027	3.77	0.65
205	34.080	36.086	0.17	0.18	2.28	79	-3.47	1.82	77	-1.8	83	0.100	99	98	2.0	0	295	431	215	318	356	323	246	83	56	82	60	72	0.027	3.98	0.65
210	34.914	36.969	0.17	0.18	2.31	79	-3.53	1.82	76	-1.8	84	0.100	99	99	1.9	-0.1	294	426	216	315	353	321	245	83	56	82	61	72	0.027	3.95	0.62
215	35.749	37.852	0.17	0.18	2.32	79	-3.87	1.83	76	-1.8	83	0.100	99	99	1.8	-0.1	293	422	218	314	349	319	244	83	57	82	61	72	0.027	3.89	0.62
220	36.584	38.734	0.17	0.18	2.31	79	-3.82	1.82	76	-1.8	83	0.100	99	98	1.8	0	291	419	217	311	345	317	240	83	57	81	61	72	0.026	3.63	0.61
225	37.419	39.616	0.17	0.18	2.31	78	-3.65	1.82	76	-2	83	0.100	99	98	1.7	-0.1	286	415	217	308	342	314	236	83	58	81	62	71	0.026	3.63	0.57
230	38.254	40.499	0.17	0.18	2.30	78	-3.41	1.83	76	-2	82	0.100	99	98	1.7	0	282	412	216	305	339	311	235	83	58	81	62	71	0.025	3.63	0.58
235	39.088	41.380	0.17	0.18	2.30	78	-3.42	1.83	75	-2	82	0.100	99	98	1.6	-0.1	280	410	215	302	335	308	235	83	59	81	62	70	0.025	3.63	0.53
240	39.923	42.262	0.17	0.18	2.31	78	-3.86	1.81	75	-2	82	0.100	99	99	1.5	-0.1	277	408	213	299	331	306	233	82	59	81	62	72	0.025	3.53	0.58
245	40.757	43.144	0.17	0.18	2.31	78	-3.48	1.82	75	-1.8	81	0.100	98	98	1.5	0	274	407	213	297	329	304	230	82	60	81	63	70	0.024	3.46	0.57
250	41.591	44.025	0.17	0.18	2.31	77	-3.81	1.81	75	-1.8	81	0.100	99	98	1.4	-0.1	269	405	214	294	326	302	226	82	60	81	63	71	0.023	3.42	0.6
255	42.425	44.907	0.17	0.18	2.30	77	-3.57	1.82	75	-1.9	80	0.100	99	98	1.3	-0.1	267	403	212	291	324	299	223	82	61	80	63	70	0.023	3.34	0.59
260	43.259	45.788	0.17	0.18	2.32	77	-3.54	1.82	74	-2	80	0.100	99	98	1.3	0	262	401	212	288	323	297	219	82	61	80	63	69	0.022	3.28	0.6
265	44.092	46.670	0.17	0.18	2.32	77	-3.67	1.82	74	-2	79	0.100	98	98	1.3	0	260	398	213	286	322	296	217	82	62	80	64	69	0.021	3.33	0.61
270	44.925	47.551	0.17	0.18	2.32	77	-3.65	1.82	74	-1.8	79	0.100	98	98	1.2	-0.1	258	395	215	284	320	294	218	82	62	80	64	69	0.021	3.41	0.63
275	45.758	48.432	0.17	0.18	2.31	76	-3.39	1.83	74	-1.8	79	0.100	99	98	1.1	-0.1	255	392	214	282	318	292	215	81	62	80	64	70	0.020	3.25	0.63
280	46.591	49.314	0.17	0.18	2.31	76	-3.8	1.83	74	-1.7	78	0.100	98	98	1.1	0	252	389	212	281	317	290	213	82	62	79	64	70	0.020	3.2	0.62
285	47.424	50.196	0.17	0.18	2.31	76	-3.46	1.82	73	-1.9	78	0.100	98	99	1.0	-0.1	251	386	211	281	314	289	212	81	63	79	64	70	0.020	3.14	0.61
290	48.256	51.077	0.17	0.18	2.31	76	-3.52	1.81	73	-1.8	78	0.100	98	98	0.9	-0.08	247	382	210	281	311	286	210	82	63	79	65	69	0.019	3.01	0.59
295	49.088	51.957	0.17	0.18	2.31	75	-3.39	1.82	73	-2	78	0.100	98	98	0.9	-0.02	245	378	211	281	308	285	207	81	63	79	65	69	0.019	2.95	0.58
300	49.921	52.838	0.17	0.18	2.31	75	-3.82	1.82	73	-2	77	0.100	99	98	0.9	0	241	374	210	280	304	282	206	81	63	82	65	69	0.019	2.88	0.56
305	50.752	53.718	0.17	0.18	2.31	75	-3.7	1.82	73	-2	78	0.100	98	98	0.8	-0.1	249	371	204	279	301	281	221	82	64	82	65	68	0.022	4.41	0.85
310	51.584	54.597	0.17	0.18	2.31	75	-3.57	1.80	72	-2	79	0.100	99	98	0.7	-0.1	265	367	199	280	301	282	231	81	64	82	65	69	0.024	4.44	0.76
315	52.415	55.477	0.17	0.18	2.31	75	-3.61	1.82	72	-1.7	79	0.100	98	99	0.5	-0.16	274	365	197	282	303	284	237	82	64	81	65	68	0.025	4.48	0.71
320	53.246	56.356	0.17	0.18	2.30	75	-3.8	1.82	72	-2	79	0.100	98	98	0.5	-0.04	283	365	196	285	307	287	241	81	64	82	65	69	0.026	4.37	0.59
325	54.077	57.234	0.17	0.18	2.31	75	-3.68	1.82	72	-1.9	79	0.100	98	98	0.4	-0.1	287	366	198	286	309	289	243	82	64	81	66	68	0.027	4.12	0.68
330	54.908	58.112	0.17	0.18	2.31	74	-3.48	1.81	72	-1.8	79	0.100	99	98	0.3	-0.1	289	369	196	288	313	291	243	81	64	81	66	68	0.027	4.15	0.63
335	55.739	58.991	0.17	0.18	2.31	74	-3.66	1.82	72	-1.9	79	0.100	99	98	0.2	-0.1	288	371	195	290	315	292	241	82	64	81	66	67	0.027	3.98	0.64
340	56.570	59.870	0.17	0.18	2.31	74	-3.72	1.82	72	-1.8	79	0.100	99	98	0.1	-0.1	286	374	194	291	315	292	238	82	64	81	66	68	0.026	3.77	0.64
345	57.401	60.748	0.17	0.18	2.28	74	-3.44	1.82	72	-1.8	80	0.100	99	98	0.1	0	282	375	191	290	314	290	235	81	65	81	66	68	0.026	3.67	0.62
350	58.231	61.626	0.17	0.18	2.30	74	-3.7	1.80	72	-2	80	0.100	99	98	0.0	-0.1	279	376	190	290	313	290	232	82	65	81	66	67	0.025	3.53	0.59
Avg/Tot	58.231	61.626	0.17	0.18	2.29	78		1.82	76		94	0.099	100	100								210.8			60	84	63	72	0.039		

## Wood Heater Lab Data

Manufacturer: GHP Group                      Equipment Numbers: \_\_\_\_\_  
 Model: PH1800WS  
 Tracking No.: 2402  
 Project No.: 0418WS017E  
 Run #: 4  
 Date: 1/30/20

**TRAIN 1 (First Hour emissions)**

Sample Component	Reagent	Filter, Probe or Dish #	Weights		
			Final, mg	Tare, mg	Particulate, mg
B. Front filter catch	Filter	T194S	89.1	86.9	2.2
C. Rear filter catch	Filter				0.0
D. Probe catch*	Probe				0.0
E. Filter seals catch*	Seals				0.0

**Sub-Total**    Total Particulate, mg:    **2.2**

**TRAIN 1 (Post First Hour Change-out)**

Sample Component	Reagent	Filter, Probe or Dish #	Weights		
			Final, mg	Tare, mg	Particulate, mg
B. Front filter catch	Filter	T206AP	182.9	181.3	1.6
C. Rear filter catch	Filter				0.0
D. Probe catch*	Probe	8	115598.6	115598.5	0.1
E. Filter seals catch*	Seals	R919	3533.3	3531.1	2.2

**Sub-Total**    Total Particulate, mg:    **3.9**

**Train 1 Aggregate**    Total Particulate, mg:    **6.1**

**TRAIN 2**

Sample Component	Reagent	Filter, Probe or Dish #	Weights		
			Final, mg	Tare, mg	Particulate, mg
A. Front filter catch	Filter	T206BP	187.0	182.0	5.0
B. Rear filter catch	Filter				0.0
C. Probe catch*	Probe	15	114341.9	114341.5	0.4
D. Filter seals catch*	Seals	R920	3323.2	3321.8	1.4

Total Particulate, mg:    **6.8**

**AMBIENT**

Sample Component	Reagent	Filter # or Probe #	Weights		
			Final, mg	Tare, mg	Particulate, mg
A. Front filter catch*	Filter				0.0

Total Particulate, mg:    **0.0**

\*Particulate catch that results in a negative number, is assumed to be zero for probes and seals, negative numbers for filters are assumed to be part of the seal weight.

Component	Equations:
A. Front filter catch	Final (mg) - Tare (mg) = Particulate, mg
B. Rear filter catch	Final (mg) - Tare (mg) = Particulate, mg
C. Probe catch	Final (mg) - Tare (mg) = Particulate, mg

Technician Signature: 

## Wood Heater Test Results

Manufacturer: GHP Group  
 Model: PH1800WS  
 Project No.: 0418WS017E  
 Tracking No.: 2402  
 Run: 4  
 Test Date: 01/30/20

Burn Rate	<b>1.35 kg/hr dry</b>
Average Tunnel Temperature	94 degrees Fahrenheit
Average Gas Velocity in Dilution Tunnel - vs	19.82 feet/second
Average Gas Flow Rate in Dilution Tunnel - Qsd	12922.9 dscf/hour
Average Delta p	0.099 inches H2O
Total Time of Test	350 minutes

	AMBIENT	SAMPLE TRAIN 1	SAMPLE TRAIN 2	FIRST HOUR FILTER (TRAIN 1)
Total Sample Volume - Vm	0.000 cubic feet	58.231 cubic feet	61.626 cubic feet	9.871 cubic feet
Average Gas Meter Temperature	72 degrees Fahrenheit	78 degrees Fahrenheit	76 degrees Fahrenheit	79 degrees Fahrenheit
Total Sample Volume (Standard Conditions) - Vmstd	0.000 dscf	56.109 dscf	59.418 dscf	9.501 dscf
Total Particulates - m <sub>T</sub>	0 mg	6.1 mg	6.8 mg	2.2 mg
Particulate Concentration (dry-standard) - C <sub>p</sub> /C <sub>s</sub>	0.000000 grams/dscf	0.00011 grams/dscf	0.00011 grams/dscf	0.00023 grams/dscf
Total Particulate Emissions - E <sub>T</sub>	0.00 grams	8.20 grams	8.63 grams	2.99 grams
Particulate Emission Rate	0.00 grams/hour	1.40 grams/hour	1.48 grams/hour	2.99 grams/hour
Emissions Factor		1.04 g/kg	1.10 g/kg	0.75 g/kg
Difference from Average Total Particulate Emissions		0.22 grams	0.22 grams	

**Dual Train Comparison Results Are Acceptable**

FINAL AVERAGE RESULTS	
<b>Complete Test Run</b>	
Total Particulate Emissions - E <sub>T</sub>	8.41 grams
Particulate Emission Rate	<b>1.44 grams/hour</b>
Emissions Factor	1.07 grams/kg
<b>First Hour Emissions</b>	
Total Particulate Emissions - E <sub>T</sub>	2.99 grams
Particulate Emission Rate	2.99 grams/hour
Emissions Factor	0.75 grams/kg
7.5% of Average Total Particulate Emissions	0.63 grams


QUALITY CHECKS	
Filter Temps < 90 °F	OK
Filter Face Velocity (47 mm)	OK
Dryer Exit Temp < 80F	OK
Leakage Rate	OK
Ambient Temp (55-90°F)	OK
Negative Probe Weight Eval.	OK
Pro-Rate Variation	OK

Technician Signature:



# Wood Heater Efficiency Results - CSA B415.1

**Manufacturer:** GHP Group  
**Model:** PH1800WS  
**Date:** 01/30/20  
**Run:** 4  
**Control #:** 0418WS017E  
**Test Duration:** 350  
**Output Category:** III

Technician Signature: 

## Test Results in Accordance with CSA B415.1-09

	HHV Basis	LHV Basis
Overall Efficiency	70.2%	75.3%
Combustion Efficiency	95.7%	95.7%
Heat Transfer Efficiency	73%	78.6%

Output Rate (kJ/h)	18,289	17,349	(Btu/h)
Burn Rate (kg/h)	1.35	2.97	(lb/h)
Input (kJ/h)	26,048	24,710	(Btu/h)

Test Load Weight (dry kg)	7.86	17.32	dry lb
MC wet (%)	17.54164147		
MC dry (%)	21.27		
Particulate (g)	8.41		
CO (g)	502		
Test Duration (h)	5.83		

Emissions	Particulate	CO
g/MJ Output	0.08	4.71
g/kg Dry Fuel	1.07	63.91
g/h	1.44	86.07
lb/MM Btu Output	0.18	10.94

Air/Fuel Ratio (A/F)	15.97
----------------------	-------

VERSION:

2.2

12/14/2009

Values to be input manually

THIS DOCUMENT IS NOT AN ASTM STANDARD; IT IS UNDER CONSIDERATION WITHIN AN ASTM TECHNICAL COMMITTEE BUT HAS NOT RECEIVED ALL APPROVALS REQUIRED TO BECOME AN ASTM STANDARD. IT SHALL NOT BE REPRODUCED OR CIRCULATED OR QUOTED, IN WHOLE OR IN PART, OUTSIDE OF ASTM COMMITTEE ACTIVITIES EXCEPT WITH THE APPROVAL OF THE CHAIRMAN OF THE COMMITTEE HAVING JURISDICTION AND THE PRESIDENT OF THE SOCIETY. COPYRIGHT ASTM, 100 BARR HARBOR DRIVE, WEST CONSHOHOCKEN, PA 19428. ALL RIGHTS RESERVED.

For Usable Firebox Volumes up to 3.0 ft <sup>3</sup> - Low and Medium Fire				
Nominal Required Load Density (wet basis)	12	lb/ft <sup>3</sup>		
Usable Firebox Volume	1.78	ft <sup>3</sup>		
Total Nom. Load Wt. Target	21.36	lb		
Total Load Wt. Allowable Range	20.29	to 22.43	lb	
Core Target Wt. Allowable Range	9.612	to 13.88	lb	
Remainder Load Wt. Allowable Range	7.48	to 11.75	lb	
				Mid-Point
Core Load Fuel Pc. Wt. Allowable Range	3.20	to 5.34	lb	4.27
Remainder Load Pc. Wt. Allowable Range	2.14	to 6.41	lb	4.27
	Pc. #			
Core Load Piece Wt. Actual	1	5.30	lb	In Range
	2	3.80	lb	In Range
	3	4.10	lb	In Range
Core Load Total. Wt. Actual		13.20	lb	In Range
	Pc. #			
Remainder Load Piece Wt.	1	2.40	lb	In Range
(2 or 3 Pcs.)	2	5.40	lb	In Range
	3		lb	NA
Remainder Load Piece Weight Ratio - Small/Large		44%		In Range ≤ 67%
Remainder Load Tot. Wt. Act		7.80	lb	In Range
Total Load Wt. Actual		21.00	lb	In Range
Core % of Total Wt.		63%		In Range 45-65%
Remainder % of Total Wt.		37%		In Range 35-55%
Actual Load % of Nominal Target		98%		In Range 95-105%
Actual Fuel Load Density		11.8	lb/ft <sup>3</sup>	
Allowable Charcoal Bed Wt. Range (lb)	2.2	to 4.2		Mid-Point
Actual Charcoal Bed Wt.		2.3	lb	In Range 3.2
Actual Fuel Load Ending Wt.		0.0	lb	Valid Test ≥ 90%
Total Wt. of Fuel Burned During Test Run lb.		21.0	lb	

Fuel Piece Moisture Reading (%-dry basis)									
1	2	3	Ave.		Pc. Wt. Dry Basis				
22.3	23.6	19	21.6	In Range	4.36	lb	1.98	kg	
21.1	20.1	22.3	21.2	In Range	3.14	lb	1.42	kg	
23.5	19.5	19.7	20.9	In Range	3.39	lb	1.54	kg	
20.2	22.2	18	20.1	In Range	2.00	lb	0.91	kg	
22.4	23.4	21.8	22.5	In Range	4.41	lb	2.00	kg	
			NA	NA	NA	lb	NA	kg	
Total Load Ave. MC % (dry basis)				21.5	In Range				
Total Load Ave. MC % (wet basis)				17.7					
Total Test Load Weight (dry basis)						17.29	lb	7.84	kg
Total Fuel Weight Burned During Test Run (dry basis)						17.3	lb	7.84	kg

### Wood Heater Run Sheets

Client: GHP Group Project Number: 0418WS017E Run Number: 4  
 Model: PH1800WS Tracking Number: 2402 Date: 1/30/20  
 Test Crew: B. Jones  
 OMNI Equipment ID numbers: \_\_\_\_\_

#### Wood Heater Run Notes

##### Air Control Settings

Primary:

Secondary: fixed

3/16" from full closed

Tertiary/Pilot: n/a

Fan: on High

##### Preburn Notes

Time	Notes

##### Test Notes

Sketch test fuel configuration:

Start up procedures & Timeline:

see photo

Bypass: Not used  
 Fuel loaded by: 60 seconds  
 Door closed at: 60 seconds  
 Primary air: fully open until 11:30 minutes  
then set to 3/16" from full  
closed  
 Notes: fan on high entire test

Time	Notes
<u>60</u>	<u>changed front filter in train A</u>

Technician Signature: B. Jones

Date: 2/4/2020

### Wood Heater Run Sheets

Client: GHP Group Project Number: 0418WS017E Run Number: 4  
 Model: PH1800WS Tracking Number: 2402 Date: 1/30/20  
 Test Crew: D Davis  
 OMNI Equipment ID numbers: \_\_\_\_\_

#### Wood Heater Supplemental Data

Start Time: 1129 Booth #: \_\_\_\_\_  
 Stop Time: 17:19

**Stack Gas Leak Check:**

Initial: good Final: good

**Sample Train Leak Check:**

A: 0.0 @ 8 "Hg  
 B: 0.0 @ 6 "Hg

**Calibrations:** Span Gas CO<sub>2</sub>: 10.08 CO: 2.53

	Pre Test		Post Test	
	Zero	Span	Zero	Span
Time	<u>1113</u>	<u>1113</u>	<u>1721</u>	<u>1721</u>
CO <sub>2</sub>	<u>0.</u>	<u>10.10</u>	<u>0.01</u>	<u>9.92</u>
CO	<u>0.0</u>	<u>2.53</u>	<u>-0.00</u>	<u>2.46</u>

Air Velocity (ft/min): Initial: 250 Final: 250  
 Scale Audit (lbs): Initial: 10.0 Final: 10.0  
 Pitot Tube Leak Test: Initial: good Final: good  
 Stack Diameter (in): 6'  
 Induced Draft: 0.0  
 % Smoke Capture: 100%  
 Flue Pipe Cleaned Prior to First Test in Series:  
 Date: 1/23/20 Initials: DC

Tunnel Traverse		
Microtector Reading	dP (in H <sub>2</sub> O)	T(°F)
	<u>.080</u>	<u>79</u>
	<u>.096</u>	<u>79</u>
	<u>.102</u>	<u>79</u>
	<u>.080</u>	<u>79</u>
	<u>.074</u>	<u>79</u>
	<u>.092</u>	<u>79</u>
	<u>.096</u>	<u>79</u>
	<u>.081</u>	<u>79</u>
Center:		
	<u>.106</u>	<u>79</u>

	Initial	Middle	Ending
P <sub>b</sub> (in/Hg)	<u>2963</u>		<u>2954</u>
RH (%)	<u>45</u>		<u>50</u>
Ambient (°F)	<u>72</u>		<u>67</u>

Background Filter Volume: N/A

Tunnel Static Pressure (in H <sub>2</sub> O):	
Beginning of Test	End of Test
<u>-.278</u>	<u>-.278</u>

Technician Signature: [Signature]

Date: 2/4/2020

# **Section 4**

## **Quality Assurance/Quality Control**

## QUALITY ASSURANCE/QUALITY CONTROL

*OMNI* follows the guidelines of ISO/IEC 17025, “General Requirements for the Competence of Testing and Calibration Laboratories,” and the quality assurance/quality control (QA/QC) procedures found in *OMNI*'s Quality Assurance Manual.

*OMNI*'s scope of accreditation includes, but is not limited to, the following:

- ANSI (American National Standards Institute) for certification of product to safety standards.
- To perform product safety testing by the International Accreditation Service, Inc. (formerly ICBO ES) under accreditation as a testing laboratory designated TL-130.
- To perform product safety testing as a “Certification Organization” by the Standards Council of Canada (SCC).
- Serving as a testing laboratory for the certification of wood heaters by the U.S. Environmental Protection Agency.

This report is issued within the scope of *OMNI*'s accreditation. Accreditation certificates are available upon request.

The manufacturing facilities and quality control system to produce the PH1800WS at GHP Group, Inc. were evaluated to determine if sufficient to maintain conformance with *OMNI*'s requirements for product certification. *OMNI* has concluded that the manufacturing facilities, processes, and quality control system are adequate to produce the appliance congruous with the standards and model codes to which it was evaluated.

This report shall not be reproduced, except in full, without the written approval of *OMNI-Test Laboratories, Inc.*

**Sample Analysis**  
Analysis Worksheets  
Tared Filter, Probe, and O-Ring Data

### Wood Heater Run Sheets

Client: GHP Group Project Number: 0418WS017E Run Number: 1  
 Model: PH1800WS Tracking Number: 2402 Date: 1/29/20  
 Test Crew: B Davis  
 OMNI Equipment ID numbers: 00637, 00243A, 00592

#### ASTM E2515 Lab Sheet

Assembled By:

B Davis

Date/Time in Dessicator:

1/31/20 0825

Weighing #1	Weighing #2	Weighing #3	Weighing #4	Weighing #5
Date/Time: 2/3/20 0910	Date/Time: 2/3/20 0830	Date/Time: 2/5/20 0955		
R/H %: 11.4	R/H %: 12.6	R/H %: 9.4		
Temp: 72.5	Temp: 72.5	Temp: 72.0		
200 mg Audit: 199.9	200 mg Audit: 200.1	200 mg Audit: 199.9		
2 g Audit: 2000.4	2 g Audit: 2000.5	2 g Audit: 2000.3		
100 g Audit: 99997.8	100 g Audit: 99997.6	100 g Audit: 99997.9		
Initials: BL	Initials: TT	Initials: BL		

Train	Element	ID #	Tare (mg)	Weight (mg)	Weight (mg)	Weight (mg)	Weight (mg)	Weight (mg)
A (First Hour)	Front Filter	T1905	87.6	89.4	89.4 ✓			
	Rear Filter	T1913	87.6	87.9	88.0 ✓			
	Probe							
	O-Ring Set							
A (Remainder)	Front Filter	T188AP	171.4	172.0	171.8 ✓			
	Rear Filter							
	Probe	OES3	114769.6	114770.3	114769.8	114770.0 ✓		
	O-Ring Set	R915	3537.3	3537.7	3537.5 ✓			
B	Front Filter	T188BP	175.0	176.8	176.7 ✓			
	Rear Filter	T1923	87.3	88.1	88.2 ✓			
	Probe	4	114858.7	114859.5	114858.9	114859.1 ✓		
	O-Ring Set	R916	3321.5	3322.0	3322.1 ✓			
BG	Filter							

Technician Signature: B Davis

Date: 2/5/20



### Wood Heater Run Sheets

Client: GHP Group Project Number: 0418WS017E Run Number: 2  
 Model: PH1800WS Tracking Number: 2402 Date: 1/29/20  
 Test Crew: B DAVIS  
 OMNI Equipment ID numbers: 00637, 00283A, 00592

#### ASTM E2515 Lab Sheet

Assembled By:

B DAVIS

Date/Time in Dessicator:

1/31/20 0825

Weighing #1	Weighing #2	Weighing #3	Weighing #4	Weighing #5
Date/Time: <u>2/3/20 0840</u>	Date/Time: <u>02/04/20 0830</u>	Date/Time: <u>2/5/20 0855</u>		
R/H %: <u>11.4</u>	R/H %: <u>12.6</u>	R/H %: <u>9.4</u>		
Temp: <u>72.5</u>	Temp: <u>72.5</u>	Temp: <u>72.3</u>		
200 mg Audit: <u>199.9</u>	200 mg Audit: <u>200.1</u>	200 mg Audit: <u>199.9</u>		
2 g Audit: <u>200.4</u>	2 g Audit: <u>200.5</u>	2 g Audit: <u>200.3</u>		
100 g Audit: <u>99997.8</u>	100 g Audit: <u>99997.6</u>	100 g Audit: <u>99997.9</u>		
Initials: <u>BD</u>	Initials: <u>TT</u>	Initials: <u>BC</u>		

Train	Element	ID #	Tare (mg)	Weight (mg)	Weight (mg)	Weight (mg)	Weight (mg)	Weight (mg)
A (First Hour)	Front Filter	T193S	88.0	97.5	97.2	97.0		
	Rear Filter							
	Probe							
	O-Ring Set							
A (Remainder)	Front Filter	T189AP	173.9	176.6	176.5 ✓			
	Rear Filter							
	Probe	0E06	113710.8	113712.8	113712.1	113712.2 ✓		
	O-Ring Set	R2917	3286.4	3288.6	3288.7 ✓			
B	Front Filter	T189BP	175.6	186.9	186.7 ✓			
	Rear Filter							
	Probe	7	114981.6	114982.7	114982.1	114982.3 ✓		
	O-Ring Set	R2918	3490.7	3493.4	3493.3 ✓			
BG	Filter							

Technician Signature: BD

Date: 2/5/20

**Wood Heater Run Sheets**

Client: GHP Group Project Number: 0418WS017E Run Number: 4  
 Model: PH1800WS Tracking Number: 2402 Date: 1/30/20  
 Test Crew: B Davis  
 OMNI Equipment ID numbers: 20637, 20283A, 00592

**ASTM E2515 Lab Sheet**

Assembled By:

B Davis

Date/Time in Dessicator:

1/31/20 0825

Weighing #1	Weighing #2	Weighing #3	Weighing #4	Weighing #5
Date/Time: <u>2/3/20 840</u>	Date/Time: <u>2/03/20 8:30</u>	Date/Time: <u>1/3/20 0355</u>		
R/H %: <u>11.4</u>	R/H %: <u>12.6</u>	R/H %: <u>9.4</u>		
Temp: <u>72.5</u>	Temp: <u>72.5</u>	Temp: <u>72.3</u>		
200 mg Audit: <u>199.9</u>	200 mg Audit: <u>200.1</u>	200 mg Audit: <u>199.9</u>		
2 g Audit: <u>2000.4</u>	2 g Audit: <u>2000.5</u>	2 g Audit: <u>2000.3</u>		
100 g Audit: <u>99997.8</u>	100 g Audit: <u>99997.6</u>	100 g Audit: <u>99997.9</u>		
Initials: <u>DL</u>	Initials: <u>TT</u>	Initials: <u>DL</u>		

Train	Element	ID #	Tare (mg)	Weight (mg)	Weight (mg)	Weight (mg)	Weight (mg)	Weight (mg)
A (First Hour)	Front Filter	<u>T194S</u>	<u>86.9</u>	<u>89.0</u>	<u>89.1</u>			
	Rear Filter							
	Probe							
	O-Ring Set							
A (Remainder)	Front Filter	<u>T206AP</u>	<u>181.3</u>	<u>182.9</u>	<u>182.9</u>			
	Rear Filter							
	Probe	<u>8</u>	<u>115598.5</u>	<u>115599.7</u>	<u>115598.4</u>	<u>115598.6</u>		
	O-Ring Set	<u>R2919</u>	<u>3531.1</u>	<u>3533.1</u>	<u>3533.3</u>			
B	Front Filter	<u>T206BP</u>	<u>182.0</u>	<u>186.9</u>	<u>187.0</u>			
	Rear Filter							
	Probe	<u>15</u>	<u>114341.5</u>	<u>114342.5</u>	<u>114341.8</u>	<u>114341.9</u>		
	O-Ring Set	<u>R2920</u>	<u>3321.8</u>	<u>3323.0</u>	<u>3323.2</u>			
BG	Filter							

Technician Signature: B Davis

Date: 2/5/20

Tare Sheet: (check one)

Probes \_\_\_\_\_

47mm Filters \_\_\_\_\_

100mm Filters \_\_\_\_\_

O-Ring Pair \_\_\_\_\_

Prepared By: B Davis

Balance ID #: Omni-0637

Thermohyrometer ID #: Omni-00592 Audit Weight ID #/Mass: Omni-00834 / 5g

Placed in Dessicator:		Date: <u>12/19/19</u>	Date: <u>12/20/19</u>	Date: <u>1/2/20 0830</u>	Date: <u>1/6/20</u>	Date Used	Project Number	Run No.
Date: <u>12/19/19</u>	Time: <u>0845</u>	RH %: <u>12.1</u>	RH %: <u>19.4</u>	RH %: <u>208</u>	RH %: <u>11.3</u>			
Time: <u>0800</u>	T (°F): <u>71.9</u>	T (°F): <u>73.0</u>	T (°F): <u>69</u>	T (°F): <u>72.6</u>				
ID #	Audit: <u>4999.9</u>	Audit: <u>5000.0</u>	Audit: <u>4999.9</u>	Audit: <u>5000.0</u>				
R 911	4138.5	4138.4	-					
R 912	3344.4	3344.5	-					
R 913	4145.4	4145.5	-					
R 914	3490.5	3490.5	-					
R 915	3537.3	3537.3	-			1/29/20	0418WS017E	1
R 916	3321.3	3321.5	-			↓		↓
R 917	3286.3	3286.4	-					2
R 918	3490.7	3490.7	-					↓
R 919	3530.9	3531.1	-			1/30/20		3
R 920	3321.6	3321.8	-			↓		↓
R 921	3291.7	3292.0	3291.6	3291.7				
R 922	3344.3	3344.5	-					
R 923	3398.7	3398.9	-					
R 924	4146.7	4146.8	-					
R 925	3347.4	3347.8	3347.7					
R 926	3350.8	3350.8	-					
Initials: <u>B</u>	Initials: <u>B</u>	Initials: <u>B</u>	Initials: <u>B</u>					

Final Technician Signature: B Davis  
Control No. P-SFDP-0002.xls, Effective date: 2/1/2017

Date: 1/6/20  
79 of 139

Evaluator signature: H. J. Meyer

Tare Sheet: (check one)

Probes ✓ DR

47mm Filters ✓

100mm Filters \_\_\_\_\_

O-Ring Pair \_\_\_\_\_

Prepared By: D. Davis

Balance ID #: OMMI-00637

Thermohyrometer ID #: OMMI-00592

Audit Weight ID #/Mass: OMMI-00283A / 100mg

200mg

Placed in Dessicator:	Date: <u>7/31/19</u>	Date: <u>8-1-19</u>	Date: _____	Date: _____	Date Used	Project Number	Run No.
	Time: <u>0845</u>	Time: <u>1030</u>	Time: _____	Time: _____			
Date: <u>7/30/19</u>	RH %: <u>18.6</u>	RH %: <u>14.2</u>	RH %: _____	RH %: _____	Date Used	Project Number	Run No.
Time: <u>0800</u>	T (°F): <u>77.4</u>	T (°F): <u>76.1</u>	T (°F): _____	T (°F): _____			
ID #	Audit: <u>2001</u> <u>99997.702</u>	Audit: <u>2001</u>	Audit: _____	Audit: _____			
T185AP	173.1	173.2	-				
T185BP	172.4	172.5	-				
T186AP	172.0	172.0	-				
T186BP	172.3	172.3	-				
T187AP	173.3	173.2	-				
T187BP	173.7	173.8	-				
T188AP	171.3	171.4	-		<u>1/29/20</u>	<u>0418WS017E</u>	<u>1</u>
T188BP	175.0	175.0	-		↓	↓	↓
T189AP	173.9	173.9	-		<u>1/29/20</u>		<u>2</u>
T189BP	175.7	175.6	-		↓	↓	↓
T190S	87.7	87.6	-		<u>1/29/20</u>	<u>0418WS017E</u>	<u>1</u>
T191S	87.5	87.6	-		↓	↓	↓
T192S	87.2	87.3	-		↓		↓
T193S	87.9	88.0	-		<u>12/29/20</u>		<u>2</u>
T194S	86.9	86.9	-		<u>1/30/20</u>	↓	<u>4</u>
T195S	87.8	87.8	-				
T196S	87.9	87.9	-				
T197S	86.7	86.6	-				
T198S	86.5	86.3	-				
T199S	90.8	90.7	-				
Initials: <u>DR</u>	Initials: <u>DR</u>	Initials: _____	Initials: _____	Initials: _____			

Final Technician Signature: [Signature]  
Control No. P-SFDP-0002.xls, Effective date: 2/1/2017

Date: 8/1/17  
80 of 139

Evaluator signature: [Signature]

Tare Sheet: (check one)

Probes \_\_\_\_\_

47mm Filters

100mm Filters \_\_\_\_\_

O-Ring Pair \_\_\_\_\_

Prepared By: BDAUS

Balance ID #: OMNI-00637

Thermohygrometer ID #: OMNI-00592

Audit Weight ID #/Mass: OMNI 282A

1 200 mg

Placed in Dessicator: Date: <u>9/23/19</u> Time: <u>0825</u>	Date: <u>9/24/19</u> Time: <u>0900</u> RH %: <u>17.9</u> T (°F): <u>75.5</u> Audit: <u>200.1</u>	Date: <u>9/25/19</u> Time: <u>10:03</u> RH %: <u>21.2</u> T (°F): <u>73.4</u> Audit: <u>200.0</u>	Date: <u>9/26/19</u> Time: <u>10:13</u> RH %: <u>25.0</u> T (°F): <u>73.9</u> Audit: <u>200.1</u>	Date: _____ Time: _____ RH %: _____ T (°F): _____ Audit: _____	Date Used	Project Number	Run No.
	ID #						
T200 AP	179.1	179.1	-				
T200 BP	180.1	180.1	-				
T201 AP	177.6	177.4	-				
T201 BP	177.7	177.4	177.6	-			
T202 AP	178.6	178.3	178.3	-			
T202 BP	180.8	180.4	180.6	-			
T203 AP	179.8	179.6	-				
T203 BP	180.3	180.0	180.0	-			
T204 AP	182.1	181.8	181.6	-			
T204 BP	183.7	183.4	183.4	-			
T205 AP	183.2	183.1	-				
T205 BP	181.6	181.4	-				
T206 AP	181.5	181.1	181.3	-	1/30/20	041428017E	4
T206 BP	182.2	182.0	-		↓	↓	↓
T207 AP	179.5	179.1	179.1	-			
T207 BP	179.7	179.3	179.2	-			
T208 AP	180.1	179.8	180.0	-			
T208 BP	179.2	178.9	179.1	-			
T209 AP	178.5	178.2	178.4	-			
T209 BP	178.8	178.4	178.5	-			
Initials: <u>B<sup>2</sup></u>	Initials: <u>B<sup>2</sup></u>	Initials: <u>TT</u>	Initials: _____				

Final Technician Signature: BDAUS

Date: 9/26/19

Evaluator signature: [Signature]

Control No. P-SFDP-0002.xls, Effective date: 2/1/2017



# Calibrations

## Methods EPA 28R, ASTM E2515, ASTM E3053

ID #	Lab Name/Purpose	Log Name	Attachment Type
132	10 lb Weight	Weight Standard, 10 lb.	Calibration Certificate
16-140TT029	Platform Scale	United 1000 lb.	Calibration Certificate
650	Digital Barometer	Traceable Barometer	Calibration Certificate
283A	Audit Weights	Troemner 21pc Msas Set	Calibration Certificate
371	Sample Box / Dry Gas Meter	Apex Automated Emissions Sampling Box	Calibration Log
372	Sample Box / Dry Gas Meter	Apex Automated Emissions Sampling Box	Calibration Log
410	Microtector	Dwyer Microtector	Calibration Certificate
265	Vaneometer	Dwyer Vaneometer	Equipment Record
592	Thermohygrometer	Omega Digital Thermohygrometer	Calibration Log
594	Combustion Gas Analyzer	CAI Gas Analyzer	See Run Sheet
637	Milligram Balance	Analytical Balance - Mettler - Toledo	Calibration Certificate

## SCALE WEIGHT CALIBRATION DATA SHEET

Weight to be calibrated: 10 pounds

ID Number: OMNI-00132

Standard Calibration Weight: 10 pounds

ID Number: OMNI-00255

Scale Used: MTW-150K

ID Number: OMNI-00353

Date: 2/23/2018 By: B. Davis

Standard Weight (A) (Lb.)	Weight Verified (B) (Lb.)	Difference (A - B)	% Error
10.0	10.0	0.0	0

\*Acceptable tolerance is 1%.

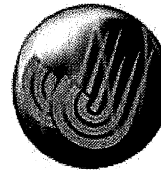
*This calibration is traceable to NIST using calibrated standard weights.*

Technician signature:  Date: 2/23/18



# Certificate of Calibration

Certificate Number: **698278**



**JJ Calibrations, Inc.**  
 7007 SE Lake Rd  
 Portland, OR 97267-2105  
 Phone 503.786.3005  
 FAX 503.786.2994

**Omni-Test Laboratories**  
 13327 NE Airport Way  
 Portland, OR 97230

PO: **190231**  
 Order Date: **04/04/2019**  
 Authorized By: **N/A**



Calibrated on: **04/18/2019**  
 \*Recommended Due: **04/18/2020**  
 Environment: **22 °C 53 % RH**  
 \* As Received: **Within Tolerance**  
 \* As Returned: **Within Tolerance**  
 Action Taken: **Calibrated**  
 Technician: **146**

Property #: **OMNI-00650**  
 User: **N/A**  
 Department: **N/A**  
 Make: **Control Company**  
 Model: **6530**  
 Serial #: **181062211**  
 Description: **Thermohygrometer / Barometer**  
 Procedure: **403406**  
 Accuracy: **±3%RH, ±.4 °C (0.8 °F), ±4mbar (0.12inHg)**

Remarks: \* Many factors may cause the unit to drift out of calibration before the recommended due date. Any reported error is the absolute value between the reference and the unit. Uncertainties include the effects of the unit.

### Standards Used

Std ID	Manufacturer	Model	Nomenclature	Due Date	Trace ID
847A	Fluke	RPM4	Reference Pressure Monitor	11/21/2019	688957
644A	Thunder Scientific	1200	Two Pressure Humidity Generator	07/30/2019	674006

Parameter	Measurement Description	Range Unit	Measurement Data				UUT	Uncertainty
			Reference	Min	Max	*Error		
<b>Before/After Humidity</b>		%	13.0	10	16	1	14 %	5.8E-01 ✓
		%	50.0	47	53	2	48 %	5.8E-01 ✓
		%	80.0	77	83	3	77 %	5.8E-01 ✓
<b>Temperature</b>		°C	20.00	19.6	20.4	0.4	19.6 °C	8.1E-02 ✓
		°C	35.00	34.6	35.4	0.4	34.6 °C	8.1E-02 ✓
		°C	50.00	49.6	50.4	0.2	49.8 °C	8.1E-02 ✓
<b>Barometer</b>		29 inHg	29.6210	29.501	29.741	0.009	29.630 inHg	8.1E-02 ✓

JJ Calibrations, Inc. certifies that this instrument has been calibrated in accordance with the JJ Calibrations Quality Assurance Manual with the stated procedure using standards that are traceable to the National Institute of Standards and Technology (NIST), or other National Measurement Institutes (NMI's), or by using natural physical constants, intrinsic standards or ratio calibration techniques. The quality system and this certificate are in compliance with ANSI/NCSL Z540-1-1994, ISO/IEC 17025-2005, ISO 10012-1, the ISO 9000 family and QS 9000. The expanded uncertainties of measurements for this calibration are based upon 95% (2 sigma) confidence limits. Unless otherwise stated, a test accuracy ratio (TAR) of 4:1, if achievable, is maintained. The results reported herein apply only to the calibration of the item described above. This report may not be reproduced, except in full, without prior written consent of JJ Calibrations, Inc.  
 JJ Calibrations, Inc. quality system has been assessed and accredited to ISO/IEC 17025:2005.

  
 Reviewer

3 Issued 04/19/2019 Rev # 15

  
 Inspector

# Certificate of Calibration

Certificate Number: **685888**



**JJ Calibrations, Inc.**

7007 SE Lake Rd  
Portland, OR 97267-2105  
Phone 503.786.3005  
FAX 503.786.2994

**Omni-Test Laboratories**  
13327 NE Airport Way  
Portland, OR 97230

PO: **180188**  
Order Date: **10/09/2018**  
Authorized By: **N/A**



Calibrated on: **10/26/2018**  
\*Recommended Due: **10/26/2023**  
Environment: **20 °C 57 % RH**  
\* As Received: **Within Tolerance**  
\* As Returned: **Within Tolerance**  
Action Taken: **Calibrated**  
Technician: **139**

Property #: **OMNI-00283A**  
User: **N/A**  
Department: **N/A**  
Make: **Troemner Inc**  
Model: **1mg-100g (Class F)**  
Serial #: **47883**  
Description: **Mass Set, 21pc**  
Procedure: **DCN 500901**  
Accuracy: **Class F**

Remarks: \* Many factors may cause the unit to drift out of calibration before the recommended due date. Any reported error is the absolute value between the reference and the unit. Uncertainties include the effects of the unit.

**This set meets Class F specifications.**  
**Received and returned eight (8) masses in a black case secured by a rubber band.**

### Standards Used

Std ID	Manufacturer	Model	Nomenclature	Due Date	Trace ID
723A	Rice Lake	1mg-200g (Class 0)	Mass Set,	03/23/2019	668240
800A	Sartorius	MSA225W100DI	Analytical Balance	12/11/2018	663857

### Measurement Data

Parameter	Measurement Description	Range Unit	Reference	Min	Max	*Error	UUT	Uncertainty
<b>Before/After</b>								Accredited = ✓
<b>Mass</b>								
Dot	200 mg		200.00030	199.4603	200.5403	0.0500	200.0503 mg	6.2E-01 ✓
	1 g		1.00000880	0.9991088	1.0009088	0.0000000	1.0000088 g	1E-03 ✓
	2 g		2.00001470	1.9989147	2.0011147	0.0003250	2.0003397 g	1.3E-03 ✓
	5 g		5.00000840	4.9985084	5.0015084	0.0000400	4.9999684 g	1.7E-03 ✓
	10 g		10.0000100	9.998010	10.002010	0.000245	9.999765 g	2.3E-03 ✓
Dot	20 g		20.0000140	19.996014	20.004014	0.000990	20.001004 g	4.6E-03 ✓
	50 g		49.9999660	49.989966	50.009966	0.000595	49.999371 g	1.1E-02 ✓
	100 g		100.000000	99.98000	100.02000	0.00194	99.99806 g	2.3E-02 ✓

JJ Calibrations, Inc. certifies that this instrument has been calibrated in accordance with the JJ Calibrations Quality Assurance Manual with the stated procedure using standards that are traceable to the National Institute of Standards and Technology (NIST), or other National Measurement Institutes (NMI's), or by using natural physical constants, intrinsic standards or ratio calibration techniques. The quality system and this certificate are in compliance with ANSI/NCCL Z540-1-1994, ISO/IEC 17025-2005, ISO 10012-1, the ISO 9000 family and QS 9000. The expanded uncertainties of measurements for this calibration are based upon 95% (2 sigma) confidence limits. Unless otherwise stated, a test accuracy ratio (TAR) of 4:1, if achievable, is maintained. The results reported herein apply only to the calibration of the item described above. This report may not be reproduced, except in full, without prior written consent of JJ Calibrations, Inc.  
JJ Calibrations, Inc. quality system has been assessed and accredited to ISO/IEC 17025:2005.

  
Reviewer

3 Issued 10/29/2018 Rev # 15

  
Inspector

# Thermal Metering System Calibration Y Factor

Manufacturer: Apex  
 Model: XC-60-EP  
 Serial Number: 0702003  
 OMNI Tracking No.: OMNI-00371  
 Calibrated Orifice:  Yes

<b>Average Gas Meter y Factor</b>
<b>0.988</b>

<b>Orifice Meter dH@</b>
<b>N/A</b>

Calibration Date: 01/03/20  
 Calibrated by: B. Davis  
 Calibration Frequency: 6 months  
 Next Calibration Due: 7/3/2020  
 Instrument Range: 1.000 cfm  
 Standard Temp.: 68 oF  
 Standard Press.: 29.92 "Hg  
 Barometric Press., Pb: 30.2 "Hg  
 Signature/Date: [Signature] 1/16/2020

[Signature] 1/17/20

### Previous Calibration Comparison

Date	<u>7/2/2019</u>	Acceptable Deviation (5%)	Deviation
y Factor	<u>0.992</u>	0.0496	0.004
Acceptance	<b>Acceptable</b>		

### Current Calibration

Acceptable y Deviation	0.020
Maximum y Deviation	0.008
Acceptable dH@ Deviation	N/A
Maximum dH@ Deviation	N/A
Acceptance	<b>Acceptable</b>

### Reference Standard \*

Standard	Model	Standard Test Meter
Calibrator	S/N	<u>OMNI-00001</u>
	Calib. Date	<u>25-Nov-19</u>
	Calib. Value	<u>0.9981</u> y factor (ref)

Calibration Parameters	Run 1	Run 2	Run 3
Reference Meter Pressure ("H2O), Pr	0.00	0.00	0.00
DGM Pressure ("H2O), Pd	3.00	1.70	0.90
Initial Reference Meter	644.9	636.8	631.5
Final Reference Meter	650.008	644.805	636.604
Initial DGM	0	0	0
Final DGM	5.112	8.045	5.184
Temp. Ref. Meter (°F), Tr	76.0	79.0	75.0
Temperature DGM (°F), Td	79.0	75.0	78.0
Time (min)	26.3	49.3	50.3
Net Volume Ref. Meter, Vr	5.108	8.005	5.104
Net Volume DGM, Vd	5.112	8.045	5.184
<b>Gas Meter y Factor =</b>	<b>0.996</b>	<b>0.982</b>	<b>0.986</b>
<b>Gas Meter y Factor Deviation (from avg.)</b>	0.008	0.006	0.002
<b>Orifice dH@</b>	N/A	N/A	N/A
<b>Orifice dH@ Deviation (from avg.)</b>	N/A	N/A	N/A

where:

1. Deviation = |Average value for all runs - current run value|
- \*\* 2.  $y = [Vr \times (y \text{ factor (ref)}) \times (Pb + (Pr / 13.6)) \times (Td + 460)] / [Vd \times (Pb + (Pd / 13.6)) \times (Tr + 460)]$
- \*\* 3.  $dH@ = 0.0317 \times Pd / (Pb (Td + 460)) \times [(Tr + 460) \times \text{time}] / Vr ]^2$

\* Reference calibration is traceable to NIST through NIST Test # 40674, Kimble ASTM E1272, or NIST traceable laboratory

\*\* Equations come from EPA Method 5

The uncertainty of measurement is  $\pm 0.14 \text{ ft}^3/\text{min}$ . This is based on the reference standard having a TAR (Test Accuracy Ratio) of at least 4:1.

## DIFFERENTIAL PRESSURE GAUGE CALIBRATION DATA SHEET

Instrument to be calibrated: Pressure Transducer

Maximum Range: 0-2" WC ID Number: OMNI-00371

Calibration Instrument: Digital Manometer ID Number: OMNI-00633

Date: 1/13/20 By: B. Davis

**This form is to be used only in conjunction with Standard Procedure C-SPC.**

Range of Calibration Point ("WC)	Digital Manometer Input ("WC)	Pressure Gauge Response ("WC)	Difference (Input - Response)	% Error of Full Span*
0-20% Max. Range 0 - 0.4	0.068	0.073	0.005	0.25
20-40% Max. Range 0.4 - 0.8	0.555	0.561	0.006	0.30
40-60% Max. Range 0.8 - 1.2	0.946	0.950	0.004	0.20
60-80% Max. Range 1.2 - 1.6	1.223	1.230	0.007	0.35
80-100% Max. Range 1.6 - 2.0	1.734	1.735	0.001	0.05

\*Acceptable tolerance is 4%.

The uncertainty of measurement is  $\pm 0.4$ " WC. This is based on the reference standard having a TAR (Test Accuracy Ratio) of at least 4:1.


Technician signature:  Date: 1/13/2020

Reviewed by:  Date: 1/17/20

Temperature Calibration EPA Method 28R, ASTM 2515							
BOOTH:	TEMPERATURE MONITOR TYPE:				EQUIPMENT NUMBER:		
Mobile	National Instruments Logger				00371, 00372		
REFERENCE METER EQUIPMENT NUMBER: 00373				Calibration Due Date: 9/11/20			
CALIBRATION PERFORMED BY:		DATE:		AMBIENT TEMPERATURE:		BAROMETRIC PRESSURE:	
B. Davis		1/13/20		70		29.95	
Input Temperature (F)	Ambient	Meter A					FB Interior
			Meter B	Filter A	Filter B	Tunnel	
0	-1	0	0	-1	-1	0	0
100	99	100	100	99	99	100	99
300	299	300	300	299	299	300	299
500	499	500	500	499	499	500	499
700	699	700	700	699	699	700	699
1000	999	1000	1000	999	999	1000	999

Input (F)	FB Top	FB Bottom	FB Back	FB Left	FB Right	Imp A	Imp B	Cat	Stack
0	0	0	0	0	0	0	-1	-1	0
100	100	100	100	100	100	100	99	99	100
300	300	300	300	300	300	300	299	299	300
500	500	500	500	500	500	500	499	499	500
700	700	700	700	700	700	700	699	699	700
1000	1000	1000	1000	1000	1000	1000	999	999	1000
1500								1499	
2000								1999	

Technician signature:  Date: 1/13/20

Reviewed By:  Date: 1/23/2020

# Thermal Metering System Calibration Y Factor

Manufacturer: Apex  
 Model: XC-60-EP  
 Serial Number: 0702004  
 OMNI Tracking No.: OMNI-00372  
 Calibrated Orifice:  Yes

<b>Average Gas Meter y Factor</b>
<b>0.985</b>

<b>Orifice Meter dH@</b>
<b>N/A</b>

Calibration Date: 01/06/20  
 Calibrated by: B. Davis  
 Calibration Frequency: 6 months  
 Next Calibration Due: 7/6/2020  
 Instrument Range: 1.000 cfm  
 Standard Temp.: 68 oF  
 Standard Press.: 29.92 "Hg  
 Barometric Press., Pb: 30.33 "Hg  
 Signature/Date: [Signature] 1/16/2020

[Signature] 1/17/20

### Previous Calibration Comparison

Date	<u>7/2/2019</u>	Acceptable Deviation (5%)	Deviation
y Factor	<u>0.989</u>	0.04945	0.004
Acceptance	<b>Acceptable</b>		

### Current Calibration

Acceptable y Deviation	0.020
Maximum y Deviation	0.014
Acceptable dH@ Deviation	N/A
Maximum dH@ Deviation	N/A
Acceptance	<b>Acceptable</b>

### Reference Standard \*

Standard	Model	Standard Test Meter
Calibrator	S/N	<u>OMNI-00001</u>
	Calib. Date	<u>25-Nov-19</u>
	Calib. Value	<u>0.9981</u> y factor (ref)

Calibration Parameters	Run 1	Run 2	Run 3
Reference Meter Pressure ("H2O), Pr	0.00	0.00	0.00
DGM Pressure ("H2O), Pd	2.00	1.00	0.80
Initial Reference Meter	663.4	672.9	682.6
Final Reference Meter	672.8	682.505	688.3
Initial DGM	0	0	0
Final DGM	9.416	9.712	5.872
Temp. Ref. Meter (°F), Tr	74.0	74.0	75.0
Temperature DGM (°F), Td	76.0	76.0	77.0
Time (min)	53.8	30.3	51.8
Net Volume Ref. Meter, Vr	9.400	9.605	5.700
Net Volume DGM, Vd	9.416	9.712	5.872
<b>Gas Meter y Factor =</b>	<b>0.995</b>	<b>0.988</b>	<b>0.971</b>
<b>Gas Meter y Factor Deviation (from avg.)</b>	0.011	0.004	0.014
<b>Orifice dH@</b>	N/A	N/A	N/A
<b>Orifice dH@ Deviation (from avg.)</b>	N/A	N/A	N/A

where:

1. Deviation = |Average value for all runs - current run value|
- \*\* 2.  $y = [Vr \times (y \text{ factor (ref)}) \times (Pb + (Pr / 13.6)) \times (Td + 460)] / [Vd \times (Pb + (Pd / 13.6)) \times (Tr + 460)]$
- \*\* 3.  $dH@ = 0.0317 \times Pd / (Pb (Td + 460)) \times [(Tr + 460) \times \text{time}] / Vr ]^2$

\* Reference calibration is traceable to NIST through NIST Test # 40674, Kimble ASTM E1272, or NIST traceable laboratory

\*\* Equations come from EPA Method 5

The uncertainty of measurement is  $\pm 0.14 \text{ ft}^3/\text{min}$ . This is based on the reference standard having a TAR (Test Accuracy Ratio) of at least 4:1.

## DIFFERENTIAL PRESSURE GAUGE CALIBRATION DATA SHEET

Instrument to be calibrated: Pressure Transducer

Maximum Range: 0-2" WC ID Number: OMNI-00372

Calibration Instrument: Digital Manometer ID Number: OMNI-00633

Date: 1/13/20 By: B. Davis

**This form is to be used only in conjunction with Standard Procedure C-SPC.**

Range of Calibration Point ("WC)	Digital Manometer Input ("WC)	Pressure Gauge Response ("WC)	Difference (Input - Response)	% Error of Full Span*
0-20% Max. Range 0 - 0.4	0.018	0.017	0.001	0.05
20-40% Max. Range 0.4 - 0.8	0.733	0.732	0.001	0.05
40-60% Max. Range 0.8 - 1.2	1.002	1.001	0.001	0.05
60-80% Max. Range 1.2 - 1.6	1.370	1.368	0.002	0.10
80-100% Max. Range 1.6 - 2.0	1.850	1.851	0.001	0.05

\*Acceptable tolerance is 4%.

The uncertainty of measurement is  $\pm 0.4$ " WC. This is based on the reference standard having a TAR (Test Accuracy Ratio) of at least 4:1.


Technician signature:  Date: 1/13/2020

Reviewed by:  Date: 1/17/20

Temperature Calibration EPA Method 28R, ASTM 2515							
BOOTH:	TEMPERATURE MONITOR TYPE:				EQUIPMENT NUMBER:		
Mobile	National Instruments Logger				00371, 00372		
REFERENCE METER EQUIPMENT NUMBER: 00373				Calibration Due Date: 9/11/20			
CALIBRATION PERFORMED BY:		DATE:		AMBIENT TEMPERATURE:		BAROMETRIC PRESSURE:	
B. Davis		1/13/20		70		29.95	
Input Temperature (F)	Ambient	Meter A					FB Interior
			Meter B	Filter A	Filter B	Tunnel	
0	-1	0	0	-1	-1	0	0
100	99	100	100	99	99	100	99
300	299	300	300	299	299	300	299
500	499	500	500	499	499	500	499
700	699	700	700	699	699	700	699
1000	999	1000	1000	999	999	1000	999

Input (F)	FB Top	FB Bottom	FB Back	FB Left	FB Right	Imp A	Imp B	Cat	Stack
0	0	0	0	0	0	0	-1	-1	0
100	100	100	100	100	100	100	99	99	100
300	300	300	300	300	300	300	299	299	300
500	500	500	500	500	500	500	499	499	500
700	700	700	700	700	700	700	699	699	700
1000	1000	1000	1000	1000	1000	1000	999	999	1000
1500								1499	
2000								1999	

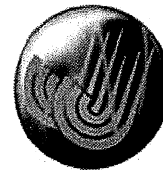
Technician signature:  Date: 1/13/20

Reviewed By:  Date: 1/23/2020



# Certificate of Calibration

Certificate Number: **712014**



**JJ Calibrations, Inc.**

7724 SE Aspen Summit Drive  
 Portland, OR 97266-9217  
 Phone 503.786.3005  
 FAX 503.786.2994

**Omni-Test Laboratories**  
 13327 NE Airport Way  
 Portland, OR 97230



PO: **190268**  
 Order Date: **10/29/2019**  
 Authorized By: **N/A**  
 Calibrated on: **11/07/2019**  
 \*Recommended Due: **11/07/2020**  
 Environment: **19 °C 38 % RH**  
 \* As Received: **Limited**  
 \* As Returned: **Limited**  
 Action Taken: **Calibrated**  
 Technician: **53**

Property #: **OMNI-00410**  
 User: **N/A**  
 Department: **N/A**  
 Make: **Dwyer**  
 Model: **1430**  
 Serial #: **OMNI-00410**  
 Description: **Microtector**  
 Procedure: **500364**  
 Accuracy: **±0.00025" WC**

Remarks: \* Many factors may cause the unit to drift out of calibration before the recommended due date. Any reported error is the absolute value between the reference and the unit. Uncertainties include the effects of the unit.

Previous limitation continued: **Calibrated micrometer head only.**

### Standards Used

Std ID	Manufacturer	Model	Nomenclature	Due Date	Trace ID
541A	Select	E8FED2	Gage Block Set, 8pc	12/30/2019	689507

Parameter

### Measurement Data

Measurement Description	Range	Unit	Reference	Min	Max	±Error	UUT	Uncertainty
<b>Before/After</b>								
<b>Length</b>								Accredited = ✓
	Inch		0.1300	0.129	0.131	0.000	0.130 Inch	8.1E-03 ✓
	Inch		0.3850	0.384	0.386	0.000	0.385 Inch	8.1E-03 ✓
	Inch		0.6150	0.614	0.616	0.000	0.615 Inch	8.1E-03 ✓
	Inch		0.8700	0.869	0.871	0.000	0.870 Inch	8.1E-03 ✓
	Inch		1.0000	0.999	1.001	0.000	1.000 Inch	8.1E-03 ✓

This instrument has been calibrated in accordance with the JJ Calibrations Quality Assurance Manual and is traceable to either the SI or to National Institute of Standards and Technology (NIST). The quality system and this certificate are in compliance with ANSI/NC SL Z540-1-1994, ISO/IEC 17025-2017, ISO 10012-1, the ISO 9000 family and QS 9000. The expanded uncertainties of measurements for this calibration are based upon 95% (2 sigma) confidence limits. Unless stated in the comments, certificates reflect the "Simple Acceptance Rule" as specified by JCGM 106:2012. Unless otherwise stated, a test accuracy ration (TAR) of 4:1, if achievable, is maintained. The results reported herein apply only to the calibration of the item described above. This report may not be reproduced, except in full, without written approval of JJ Calibrations.

  
 Reviewer

3 Issued 11/08/2019 Rev # 15

  
 Inspector



## VWR Temperature Hygrometer Calibration Procedure and Data Sheet

Frequency: Every Two Years

Step 1: Locate NIST traceable standard.

Step 2: Place unit to be calibrated, tracking No. OMNI-00592, inside OMNI desiccate box on the same shelf with the NIST traceable standard.

Step 3: After a period of not less than four hours record the temperature and humidity of both units in the spaces provide below.

Step 4: If the unit to be calibrated matches the NIST standard within  $\pm 4\%$ , it is acceptable. If not, the unit needs to be sent to a repair company or replaced.

### Verification Data:

Date: 1/29/19  
1/29/19 Technician: B. Davis

Time in desiccate: 0840 Recording time: 1415

NIST Standard Temperature: 70.2 °F NIST Standard Humidity: 14.6

Test Unit Temperature Reading: 69.9 °F Test Unit Humidity Reading: 12.1

Test unit OMNI-00592 is  or was not  within acceptable limits.

Technician Signature: [Signature]

Comments: A difference of 2.5% was found, with a full scale of 90%  
on the instrument this gives a 2.77% deviation.

# ZRE

# NDIR/O<sub>2</sub>



# USER'S

# MANUAL



1312 West Grove Avenue  
Orange, CA 92865-4134  
Phone: 714-974-5560 Fax: 714-921-2531  
[www.gasanalyzers.com](http://www.gasanalyzers.com)

# Certificate of Calibration

Certificate Number: **716748**



**JJ Calibrations, Inc.**

7724 SE Aspen Summit Drive  
Portland, OR 97266-9217  
Phone 503.786.3005  
FAX 503.786.2994

**Omni-Test Laboratories**  
13327 NE Airport Way  
Portland, OR 97230

OnSite

PO: **190269**

Order Date: **01/20/2020**

Authorized By: **N/A**



Calibrated on: **01/20/2020**

\*Recommended Due: **07/20/2020**

Environment: **20 °C 40 % RH**

\* As Received: **Within Tolerance**

\* As Returned: **Within Tolerance**

Action Taken: **Calibrated**

Technician: **135**

Property #: **OMNI-00637**  
User: **N/A**  
Department: **N/A**  
Make: **Mettler Toledo**  
Model: **MS104TS/00**  
Serial #: **B729400181**  
Description: **Analytical Scale, 120g**  
Procedure: **DCN 500887**  
Accuracy: **±0.0005g**

Remarks: \* Many factors may cause the unit to drift out of calibration before the recommended due date. Any reported error is the absolute value between the reference and the unit. Uncertainties include the effects of the unit.

## Standards Used

Std ID	Manufacturer	Model	Nomenclature	Due Date	Trace ID
723A	Rice Lake	1mg-200g (Class 0)	Mass Set,	05/22/2020	694890

## Measurement Data

Parameter	Measurement Description	Range	Unit	Reference	Min	Max	*Error	UUT	Uncertainty
Before/After Force									Accredited = $\bar{U}$
			g	10.00000	9.9995	10.0005	0.0001	10.0001 g	9.7E-05 $\bar{U}$
			g	30.00000	29.9995	30.0005	0.0003	30.0003 g	1.2E-04 $\bar{U}$
			g	60.00000	59.9995	60.0005	0.0002	60.0002 g	1.8E-04 $\bar{U}$
			g	90.00000	89.9995	90.0005	0.0001	90.0001 g	2.4E-04 $\bar{U}$
			g	120.00000	119.9995	120.0005	0.0000	120.0000 g	3E-04 $\bar{U}$

This instrument has been calibrated in accordance with the JJ Calibrations Quality Assurance Manual and is traceable to either the SI or to National Institute of Standards and Technology (NIST). The quality system and this certificate are in compliance with ANSI/NC SL Z540-1-1994, ISO/IEC 17025-2017, ISO 10012-1, the ISO 9000 family and QS 9000. The expanded uncertainties of measurements for this calibration are based upon 95% (2 sigma) confidence limits. Unless stated in the comments, certificates reflect the "Simple Acceptance Rule" as specified by JCGM 106:2012. Unless otherwise stated, a test accuracy ratio (TAR) of 4:1, if achievable, is maintained. The results reported herein apply only to the calibration of the item described above. This report may not be

Reviewer

3 Issued 01/22/2020 Rev # 15

Inspector

## **Example Calculations**

## Equations and Sample Calculations

Manufacturer: GHP Group  
Model: PH1800WS  
Run: 2  
Category:

Equations used to calculate the parameters listed below are described in this appendix. Sample calculations are provided for each equation. The raw data and printout results from a sample run are also provided for comparison to the sample calculations.

$M_{FTAdb}$  - Total weight of fuel dry basis, kg

BR - Dry burn rate, kg/hr

$V_s$  - Average gas velocity in the dilution tunnel, ft/sec

$Q_{sd}$  - Average gas flow rate in dilution tunnel, dscf/hr

$V_{m(std)}$  - Volume of gas sampled, corrected to dry standard conditions, dscf

$m_n$  - Total particulate matter collected, mg

$C_s$  - Concentration of particulate matter in tunnel gas, dry basis, corrected to standard conditions, g/dscf

$E_T$  - Total particulate emissions, g

PR - Proportional rate variation

$PM_R$  - Particulate emissions for test run, g/hr

$PM_F$  - Particulate emission factor for test run, g/dry kg of fuel burned

**M<sub>FTAdb</sub> - Total weight of fuel crib excluding nails, dry basis, kg**

$$M_{FTAdb} = M_{Cdb}$$

Sample calculation:

$$M_{FTAdb} = 7.66$$

$$= 7.66 \text{ kg}$$



**BR – dry burn rate, kg/hr**

$$BR = \frac{60 M_{FTAdb}}{\theta}$$

Where,

$\theta$  = Total length of test run, min

Sample Calculation:

$$M_{Bdb} = 7.66 \quad \text{kg}$$

$$\theta = 420 \quad \text{min}$$

$$BR = \frac{60 \times 7.66}{420}$$

$$BR = \mathbf{1.09} \quad \text{kg/hr}$$

**V<sub>s</sub> – Average gas velocity in the dilution tunnel, ft/sec**

ASTM E2515 equations (9)

$$V_s = F_p \times k_p \times C_p \times (\sqrt{\Delta P})_{avg} \times \sqrt{\frac{T_{s(avg)}}{P_s \times M_s}}$$

Where:

- F<sub>p</sub> = Adjustment factor for center of tunnel pitot tube placement,  $F_p = \frac{V_{strav}}{V_{scent}}$ , ASTM E2515 Equation (1)
- V<sub>scent</sub> = Dilution tunnel velocity calculated after the multi-point pitot traverse at the center, ft/sec
- V<sub>strav</sub> = Dilution tunnel velocity calculated after the multi-point pitot traverse, ft/sec
- k<sub>p</sub> = Pitot tube constant, 85.49
- C<sub>p</sub> = Pitot tube coefficient: 0.99, unitless
- ΔP\* = Velocity pressure in the dilution tunnel, in H<sub>2</sub>O
- T<sub>s</sub> = Absolute average gas temperature in the dilution tunnel, °R; (°R = °F + 460)
- P<sub>s</sub> = Absolute average gas static pressure in dilution tunnel, = P<sub>bar</sub> + P<sub>g</sub>, in Hg
- P<sub>bar</sub> = Barometric pressure at test site, in. Hg
- P<sub>g</sub> = Static pressure of tunnel, in. H<sub>2</sub>O; (in Hg = in H<sub>2</sub>O/13.6)
- M<sub>s</sub> = \*\*The dilution tunnel wet molecular weight; M<sub>s</sub> = 28.78 assuming a dry weight of 29 lb/lb-mole

Sample calculation:

$$F_p = \frac{20.40}{21.87} = 0.933$$

$$V_s = 0.933 \times 85.49 \times 0.99 \times 0.313 \times \left( \frac{85.6 + 460}{\left( \frac{29.52 + \frac{-0.28}{13.6}}{28.78} \right)^{1/2}} \right)$$

$$V_s = \mathbf{19.80 \text{ ft/s}}$$

\*The ASTM test standard mistakenly has the square root of the average delta p instead of the average of the square root of delta p. The current EPA Method 2 is also incorrect. This was verified by Mike Toney at EPA.

\*\*The ASTM test standard mistakenly identifies M<sub>s</sub> as the dry molecular weight. It should be the wet molecular weight as indicated in EPA Method 2.

**Q<sub>sd</sub> – Average gas flow rate in dilution tunnel, dscf/hr**

ASTM E2515 equation (3)

$$Q_{sd} = 3600 \times (1 - B_{ws}) \times v_s \times A \times \frac{T_{std}}{T_{s(avg)}} \times \frac{P_s}{P_{std}}$$

Where:

- 3600 = Conversion from seconds to hours (ASTM method uses 60 to convert in minutes)
- B<sub>ws</sub> = Water vapor in gas stream, proportion by volume; assume 2%
- A = Cross sectional area of dilution tunnel, ft<sup>2</sup>
- T<sub>std</sub> = Standard absolute temperature, 528 °R
- P<sub>s</sub> = Absolute average gas static pressure in dilution tunnel, = P<sub>bar</sub> + P<sub>g</sub>, in Hg
- T<sub>s(avg)</sub> = Absolute average gas temperature in the dilution tunnel, °R; (°R = °F + 460)
- P<sub>std</sub> = Standard absolute pressure, 29.92 in Hg

Sample calculation:

$$Q_{sd} = 3600 \times (1 - 0.02) \times 19.80 \times 0.196 \times \frac{528}{85.6 + 460} \times \frac{29.5 + \frac{-0.28}{13.6}}{29.92}$$

$$Q_{sd} = \mathbf{13088.0} \text{ dscf/hr}$$

$V_{m(std)}$  – Volume of Gas Sampled Corrected to Dry Standard Conditions, dscf  
 ASTM E2515 equation (6)

$$V_{m(std)} = K_1 V_m Y \frac{P_{bar} + \left( \frac{\Delta H}{13.6} \right)}{T_m}$$

Where:

- $K_1$  = 17.64 °R/in. Hg
- $V_m$  = Volume of gas sample measured at the dry gas meter, dcf
- $Y$  = Dry gas meter calibration factor, dimensionless
- $P_{bar}$  = Barometric pressure at the testing site, in. Hg
- $\Delta H$  = Average pressure differential across the orifice meter, in. H<sub>2</sub>O
- $T_m$  = Absolute average dry gas meter temperature, °R

Sample Calculation:

Using equation for Train 1:

$$V_{m(std)} = 17.64 \times 70.074 \times 0.992 \times \frac{\left( 29.52 + \frac{2.30}{13.6} \right)}{\left( 75.2 + 460 \right)}$$

$$V_{m(std)} = \mathbf{68.021} \text{ dscf}$$

Using equation for Train 2:

$$V_{m(std)} = 17.64 \times 73.491 \times 0.989 \times \frac{\left( 29.52 + \frac{1.79}{13.6} \right)}{\left( 72.6 + 460 \right)}$$

$$V_{m(std)} = \mathbf{71.381} \text{ dscf}$$

Using equation for ambient train:

$$V_{m(std)} = 17.64 \times 0.00 \times 0 \times \frac{\left( 29.52 + \frac{0.00}{13.6} \right)}{\left( 68.3 + 460 \right)}$$

$$V_{m(std)} = \mathbf{0} \text{ dscf}$$

**$m_n$  – Total Particulate Matter Collected, mg**

ASTM E2515 Equation (12)

$$m_n = m_p + m_f + m_g$$

Where:

$m_p$  = mass of particulate matter from probe, mg

$m_f$  = mass of particulate matter from filters, mg

$m_g$  = mass of particulate matter from filter seals, mg

Sample Calculation:

Using equation for Train 1 (first hour):

$$m_n = 0.0 + 9.0 + 0.0$$

$$m_n = 9.0 \text{ mg}$$

Using equation for Train 1 (post-first hour):

$$m_n = 1.4 + 2.6 + 2.3$$

$$m_n = 6.3 \text{ mg}$$

Train 1 aggregate:

$$m_n = 9.0 + 6.3$$

$$m_n = \mathbf{15.3} \text{ mg}$$

Using equation for Train 2:

$$m_n = 0.7 + 11.1 + 2.6$$

$$m_n = \mathbf{14.4} \text{ mg}$$

**C<sub>s</sub> - Concentration of particulate matter in tunnel gas, dry basis, corrected to standard conditions, g/dsc**  
ASTM E2515 equation (13)

$$C_s = K_2 \times \frac{m_n}{V_{m(\text{std})}}$$

Where:

K<sub>2</sub> = Constant, 0.001 g/mg

m<sub>n</sub> = Total mass of particulate matter collected in the sampling train, mg

V<sub>m(std)</sub> = Volume of gas sampled corrected to dry standard conditions, dscf

Sample calculation:

For Train 1:

$$C_s = 0.001 \times \frac{15.3}{68.02}$$

$$C_s = \mathbf{0.00022} \text{ g/dscf}$$

For Train 2

$$C_s = 0.001 \times \frac{14.4}{71.38}$$

$$C_s = \mathbf{0.00020} \text{ g/dscf}$$

For Ambient Train

$$C_r = 0.001 \times \frac{0.0}{0}$$

$$C_r = \mathbf{0} \text{ g/dscf}$$

**$E_T$  – Total Particulate Emissions, g**

ASTM E2515 equation (15)

$$E_T = (C_s - C_r) \times Q_{std} \times \theta$$

Where:

- $C_s$  = Concentration of particulate matter in tunnel gas, g/dscf
- $C_r$  = Concentration particulate matter room air, g/dscf
- $Q_{std}$  = Average dilution tunnel gas flow rate, dscf/hr
- $\theta$  = Total time of test run, minutes

Sample calculation:

For Train 1

$$E_T = ( \underline{0.000225} - 0 ) \times \underline{13088.0} \times \underline{420} / 60$$
$$E_T = \underline{20.61} \text{ g}$$

For Train 2

$$E_T = ( \underline{0.000202} - 0 ) \times \underline{13088.0} \times \underline{420} / 60$$
$$E_T = \underline{18.48} \text{ g}$$

Average

$$E = \underline{19.54} \text{ g}$$

Total emission values shall not differ by more than 7.5% from the total average emissions

$$7.5\% \text{ of the average} = \underline{1.47}$$

$$\text{Train 1 difference} = \underline{1.06}$$

$$\text{Train 2 difference} = \underline{1.06}$$

**PR - Proportional Rate Variation**

ASTM E2515 equation (16)

$$PR = \left[ \frac{\theta \times V_{mi} \times V_s \times T_m \times T_{si}}{\theta_i \times V_m \times V_{si} \times T_{mi} \times T_s} \right] \times 100$$

Where:

- $\theta$  = Total sampling time, min
- $\theta_i$  = Length of recording interval, min
- $V_{mi}$  = Volume of gas sample measured by the dry gas meter during the "ith" time interval, dcf
- $V_m$  = Volume of gas sample as measured by dry gas meter, dcf
- $V_{si}$  = Average gas velocity in the dilution tunnel during the "ith" time interval, ft/sec
- $V_s$  = Average gas velocity in the dilution tunnel, ft/sec
- $T_{mi}$  = Absolute average dry gas meter temperature during the "ith" time interval, °R
- $T_m$  = Absolute average dry gas meter temperature, °R
- $T_{si}$  = Absolute average gas temperature in the dilution tunnel during the "ith" time interval, °R
- $T_s$  = Absolute average gas temperature in the dilution tunnel, °R

Sample calculation (for the first 1 minute interval of Train 1):

$$PR = \left( \frac{420 \times 0.861 \times 19.80 \times (135.0 + 460) \times (75.2 + 460)}{5 \times 70.07 \times 19.82 \times (85.6 + 460) \times (78.0 + 460)} \right) \times 100$$

$$PR = \underline{112} \%$$



**PM<sub>R</sub> – Particulate emissions for test run, g/hr**

$$PM_R = 60 (E_T/\theta)$$

Where,

E<sub>T</sub> = Total particulate emissions, grams

θ = Total length of full integrated test run, min

Sample Calculation:

$$E_T (\text{Dual train average}) = 19.54 \text{ g}$$

$$\theta = 420 \text{ min}$$

$$PM_R = 60 \times ( 19.54 / 420 )$$

$$PM_R = \mathbf{2.79} \text{ g/hr}$$

**PM<sub>F</sub>** – Particulate emission factor for test run, g/dry kg of fuel burned  
ASTM E2780 equation (7)

$$PM_F = E_T / M_{FTAdb}$$

Sample Calculation:

$$E_T (\text{Dual train average}) = 19.54 \text{ g}$$

$$M_{Bdb} = 7.66 \text{ kg}$$

$$PM_F = 19.54 / 7.66$$

$$PM_F = \mathbf{2.55} \text{ g/kg}$$

*GHP Group, Inc.*  
*Model: PH1800WS*  
*Report Number:0418WS017E*

# **Appendix A**

## **Manufacturer's Installation/Operation Instructions - Labels**



Tested & Listed By

Portland Oregon USA

OMNI-Test Laboratories, Inc.

# LISTED SOLID FUEL BURNING SPACE HEATER POELE A COMBUSTIBLES SOLIDES HOMOLOGUE CALENTADOR A COMBUSTIBLE S ÓLIDO

Serial No.

TESTED TO: UL 1482-11 (R2015)/ULC-S627-00  
REPORT NO. 0418WS017S/0418WS017E

TESTED EMISSIONS VALUE: 2.18 grams/ hr  
TEST METHOD: ASTM 2515, ASTM 3053

CONTACT LOCAL BUILDING OFFICIALS ABOUT RESTRICTIONS AND INSTALLATION INSPECTION IN YOUR AREA. A MINIMUM CLEARANCE OF 18 INCHES (457 mm) TO THE CHIMNEY CONNECTOR MAY BE REQUIRED BY THE AUTHORITY HAVING JURISDICTION.

DIMENSIONS: INCHES (mm)  
WITH SINGLE WALL CONNECTOR

MIS A L'EPREUVE SELON: UL 1482-11 (R2015)/ULC-S627-00  
RAPPORT NO 0418WS017S/0418WS017E

LA VALEUR DES ÉMISSIONS TESTÉ 2.18 grams/ hr  
MÉTHODE D'ESSAI: ASTM 2515, ASTM 3053

LOCAUX DE LA CONSTRUCTION ET DE LA PREVENTION DES INCENDIES AU SUJET DES RESTRICTIONS ET INSPECTIONS D'INSTALLATION DAND VOTRE SECTEUR. UN ESPACE DE 18 POUCES (457 mm) JUSQU'AU RACCORD DE LE CHEMINÉE PEUT ETRE EXIGE PAR LE CORPS CONSTITUTE AVANT JURIDICTION.

DIMENSIONS: POUCES (mm)  
AVEC RACCORD DE CHEMINÉE PAROI SIMPLE

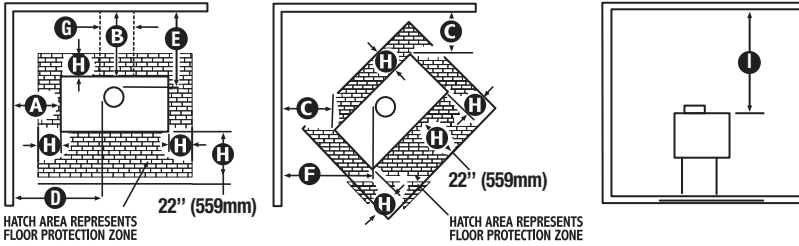
CUMPLE CON PRUEBAS: UL 1482-11 (R2015)/ULC-S627-00  
INFORME NO. 0418WS017S/0418WS017E

VALOR DE LAS EMISIONES ANALIZADAS: 2.18 grams/ hr  
MÉTODO DE ENSAYO : ASTM 2515, ASTM 3053

CONTACTE SUS AUTORIDADES LOCALES DE CONSTRUCCION SOBRE RESTRICCIONES E INSPECCIONES DE INSTALACION EN SU AREA. ES POSIBLE QUE LAS AUTORIDADES COMPETENTES EXIJAN UN ESPACIAMIENTO MINIMO DE 18 PULGADAS (457 mm) CON RESPECTO AL CONECTOR DE LA CHIMENEA.

DIMENSIONES: PULGADAS (mm)  
CON CONECTOR DE PARED SIMPLE

## MINIMUM CLEARANCES TO COMBUSTIBLES / D ÉGAGEMENTS MINIMUM AUX COMBUTIBLES / SEPARACIONES MINIMAS A LOS COMBUSTIBLES



- A) Side of stove to side wall / Côté de fourneau au mur latéral / Lado de la estufa a la pared lateral \_\_\_\_\_ 25" (635mm)
  - B) Rear of stove to back wall / Arrière du fourneau pour soutenir le mur / Parte posterior de la estufa para mover hacia atrás la pared \_\_\_\_\_ 19" (483mm)
  - C) Corner of stove top to side wall / Le coin du dessus de fourneau au mur latéral / La esquina de la tapa de la estufa a la pared lateral \_\_\_\_\_ 16" (407 mm)
  - D) Flue to side wall / Conduite de cheminée au mur latéral / Tubo a la pared lateral \_\_\_\_\_ 34" (864mm)
  - E) Flue to back wall / Conduite de cheminée pour soutenir le mur / Tubo para mover hacia atrás la pared \_\_\_\_\_ 22" (559mm)
  - F) Flue to corner / Flue à coin / Humeros à coin \_\_\_\_\_ 25" (635 mm)
  - G) 2" beyond pipe when pipe exits horizontally through wall / 2 po au-delà du tuyau quand le tuyau sort horizontalement par un mur / 2" de separación cuando existan tuberías horizontales a lo largo de la pared
  - H) Floor protection / Protection de plancher / Protección del piso  
Rear/Arrière/Parte posterior: 8"(203mm) Left/Gauche/Izquierdo: 8"(203mm) Right/Droite/La derecha: 8"(203mm) Front/Avant/Frente: USA 16"(407mm) CAN 18"(458mm)
  - I) Top of stove to ceiling / Dessus de fourneau au plafond / Tapa de la estufa al techo \_\_\_\_\_ 55" (1397mm)
- Noncombustible material with a minimum thickness of 0.5" and an R value of "1.06" / Matériel incombustible et durable dont l'épaisseur fait au moins 12,7 mm (0.5 po) et dont la valeur d'isolation thermique « R » est d'un minimum de 1,06 / Material duradero no combustible con un grosor mínimo de 12,7 cm (0.5") y un valor R de 1.06

FUEL: FOR USE WITH SOLID WOOD FUEL ONLY. DO NOT USE GRATE OR ELEVATE FIRE - BUILD FIRE DIRECTLY ON HEARTH. DO NOT OBSTRUCT SPACE UNDER HEATER. SPECIAL METHODS ARE REQUIRED WHEN PASSING THROUGH A WALL OR CEILING. SEE INSTRUCTIONS AND BUILDING CODES. DO NOT CONNECT THIS UNIT TO A CHIMNEY FLUE SERVING ANOTHER APPLIANCE. FOR SAFE OPERATION, INSTALL IN ACCORDANCE WITH MANUFACTURERS INSTRUCTIONS. KEEP HEATER DOOR CLOSED WHILE IN OPERATION.

### PREVENT HOUSE FIRES

INSTALL AND USE ONLY IN ACCORDANCE WITH THE MANUFACTURER'S INSTRUCTIONS AND LOCAL BUILDING CODES. FLOOR PROTECTION: UNIT MUST BE PLACED ON NONCOMBUSTIBLE FLOOR ONLY EXTENDING 22 IN. (559mm) IN FRONT AND 8 IN.(203 mm) TO THE SIDES AND BACK OF UNIT.

THE FLOOR PROTECTOR MUST BE A DURABLE NONCOMBUSTIBLE MATERIAL WITH A MINIMUM THICKNESS OF 0.5" AND AN R VALUE OF "1.06".

CHIMNEY TYPE: MINIMUM 6 IN (152mm) DIAMETER.  
CHIMNEY CONNECTOR: 6 IN (152 mm) DIAMETER MINIMUM 24 GAUGE STEEL.

HEATER MUST BE INSTALLED WITH LEGS OR PEDESTAL PROVIDED. ATTACH AS SHOWN IN INSTALLATION INSTRUCTIONS.

GLASS REPLACEMENT - REPLACE ONLY WITH GHP REPLACEMENT CERAMIC GLASS PART #75-21-514

OPTIONAL BLOWER: MODEL PBAR-2427 120 VOLTS FREQ 60 Hz 1.0 AMPS 2900 RPM

ANGER: RISK OF ELECTRIC SHOCK  
DISCONNECT POWER BEFORE SERVICING UNIT.

THIS WOOD HEATER NEEDS PERIODIC INSPECTION AND REPAIR FOR PROPER OPERATION. CONSULT THE OWNER'S MANUAL FOR FURTHER INFORMATION. IT IS AGAINST FEDERAL REGULATIONS TO OPERATE THIS WOOD HEATER IN A MANNER INCONSISTENT WITH THE OPERATING INSTRUCTIONS IN THE OWNER'S MANUAL

## U.S. ENVIRONMENTAL PROTECTION AGENCY CERTIFIED TO COMPLY WITH 2020 PARTICULATE EMISSION STANDARDS USING CORDWOOD.

MADE IN U.S.A. BY: GHP GROUP INC, 6440 W HOWARD ST., NILES IL 60714  
FABRIQUE AU ETATS UNIS PAR: GHP GROUP INC, 6440 W HOWARD ST., NILES IL 60714  
HECHO EN LOS EE.UU. POR EL GRUPO GHP, INC, 6440 W HOWARD ST., NILES IL 60714

COMBUSTIBLE: PUR USAGE AVEC BOIS SEULEMENT. NE PAS UTILISER DE CHENETS POUR ELEVER LE FEU CONSTRUIT LE FEU DIRECTEMENT SUR LES BRIQUES. NE RIEN ENTREPOSER SOUS L'APPAREIL. DES METHODES SPECIALES SONT REQUISES LORS DU PERCAGE D'UN MUR OU PLAFOND. VERIFIER LES DIRECTIVES ET LES CODES DE CONSTRUCTION. NE PAS ACCORDER A LA CHIMENEE D'UN AUTRE APPAREL. POUR UTILISATION SECURITAIRE. SUIVRE ATTENTIVEMENT LES INSTRUCTIONS DU FABRICANT. GARDEZ LA PORTE DU POELE FERMEE PENDANT LE FONCTIONNEMENT.

### PREVENTION DES INCENDIES

POUR INSTALLATION ET UTILISATION CONF ORMEZ AUX INSTRUCTIONS DU FABRICANT ET AUX CODES LOCAUX DU BATIMENT. PROTECTION DES PLANCHERS: IL FAUT INSTALLER L'APPAREIL SUR UN PLANCHER NONCOMBUSTIBLE SEULEMENT S'ETENDANT 22 PO (559mm) A L'ARRIERE ET SUR LES COTES DE L'APPAREIL.

LE PROTECTEUR DE PLANCHER DOIT ÊTRE FAIT D'UN MATÉRIEL INCOMBUSTIBLE ET DURABLE DONT L'ÉPAISSEUR FAIT AU MOINS 12,7 MM (0.5 PO) ET DONT LA VALEUR D'ISOLATION THERMIQUE « R » EST D'UN MINIMUM DE 1,06.

TYPE DE CHIMENEE: DIAMETRE MINIMAL 6 PO (152mm)  
RACCORD DE CHIMENEE: DIAMETRE 6 PO (152mm)  
CALIBRE DE 24 ACIER.

L'APPAREIL DOIT ETRE INSTALLER AVEC LES PIED OU LE SOCLE FOURNI. ATTACHEZ COMME MONTRER DANS LES INSTRUCTIONS D'INSTALLATION. REMPLACEMENT DU VERRE-REMPLECEZ SEULEMENT AVEC LE REMPLACEMENT GHP. NUMERO DE PARTIE DU VERRE 75-21-514

SOUFFLERIE FACULTAIVE: MODEL PBAR-2427 120 VOLTS FREQ 60Hz 1.0 AMPS 2900 RPM

ANGER: RISQUE DE SECOURS ELECTRIQUE.  
DEDRANCHEZ AVANT DE PROCEDER A L'ENTRETIEN.

CETTE CHAUFFRETTE REQUIERT L'INSPECTION ET REPARATION PERIODIQUE POUR ASSURER UN RENDEMENT EFFICACE. CONSULTEZ LE GUIDE DU CONSOMMATEUR POUR PLUS D'INFORMATION. SELON LES REGLES D'USAGE FEDERALES, IL EST INTERDIT D'OPERER CETTE CHAUFFRETTE DE FAÇON CONTRADICTOIRE AVEC LE GUIDE DU CONSOMMATEUR

COMBUSTIBLE: PARA USO CON MADERA UNICAMENTE. NO UTILICE PARRILLA PARA ELEVARE EL FUEGO - GENERE EL FUEGO DIRECTAMENTE DENTRO DEL CALENTADOR. DEIE LIBRE EL ES PACIO DEBAJO DEL CAENTADOR. SE REQUIEREN METODOS ESPECIALES PARA HACER INSTALACION A TRAVES DE UNA PARED O DEL TECHO. CONSULTE LAS INSTRUCCIONES Y LAS NORMAS DE CONSTRUCCION. NO CONECTE ETA UNIDAD A UN TUBO DE CHIMENEA CORERSPONDIENTE A OTRO APARATO. PARA UNA OPERACION SEGURA, LA INSTALACION DEBE SER HECHA DE ACUERDO CON LAS INSTRUCCIONES DEL FABRICANTE. MANTENGA CERRADA LA PUERTA DEL CALENTADOR MIENTRAS ESTE EN FUNCIONAMIENTO.

### COMO PREVENIR UN INCENDIO EN LA CASA

INSTALE Y UTILICE EL CALEN TADOR UNICAMENTE DE ACUERDO CON LAS INSTRUCCIONES DEL FABRICANTE Y CON LAS NORMAS LOCALES DE CONSTRUCCION. PROTECCION DEL PISO: LA UNIDAD DEBE SER COLOCADA PISO NO INFLAMABLE SOLAMENTE EXTENDIÉNDOSE POR DELANTE 22 Pulg. (559 mm) A LOS LADOS Y POR DETRAS DE LA UNIDAD.

EL PROTECTOR DE PISO DEBE ESTAR COMPUESTO DE UN MATERIAL DURADERO NO COMBUSTIBLE CON UN GROSOR MÍNIMO DE 12,7 CM (0.5") Y UN VALOR R DE 1.06.

TIPO DE CHIMENEA: DIAMETRO MINIMO DE 6 Pulg. (152 mm). APROBADO PARA USO RESIDENCIAL CONECTOR DE CHIMENEA: 6 Pulg. (152mm) DE DIAMETRO. ACERO DE CALIBRE 24 MINIMO.EL CALEN TADOR DEVE INSTALARSE CON LAS PATAS O EL PEDESTAL SUMINISTRADO. HAGA EL MOENTUE COMO SE MUESTRA EN LAS INSTRUCCIONES DE INSTALACION.

PARA REEMPLAZAR VIDRIO - CAMIBIELO UNICAMENTE POR EL VIDRIO GHP DE REPUESTO - NUMERO DE PIEZA 75-21-514

VENTILADOR OPCIONAL: MODELO PBAR-2427 120 VOLTIOS; FREQ. 60 HZ; 1,0 AMPS; 2900 RPM

PELIGRO: RIESGO DE DESCARGA ELECTRICA.  
DESCONECTE LA UNIDAD DE LA CORRIENTE ANTES DE HACER MANTENIMIENTO A LA MISMA.

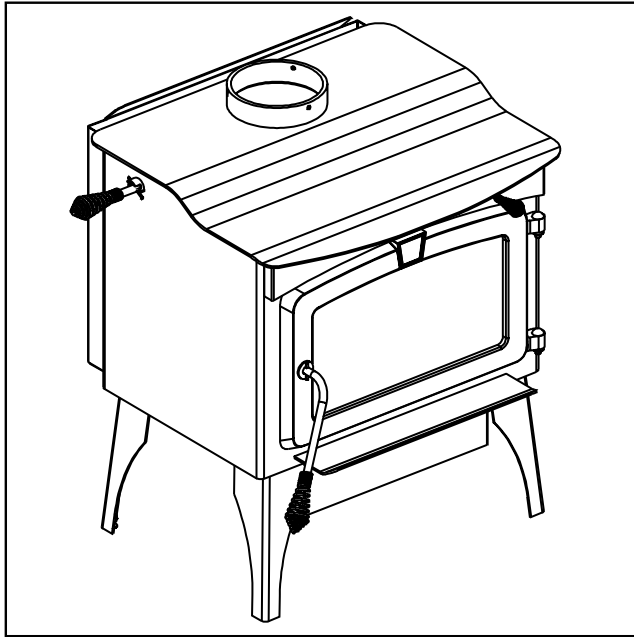
ESTE CALENTADOR DE MADERA NECESITA INSPECCIÓN PERIÓDICA Y REPARACIÓN PARA OPERACIÓN ADECUADA. CONSULTE EL MANUAL DEL PROPIETARIO PARA OBTENER MÁS INFORMACIÓN. ES EN CONTRA DE LAS REGULACIONES FEDERALES PARA OPERAR ESTE CALENTADOR DE MADERA DE MANERA INCOMPATIBLE CON LAS INSTRUCCIONES DE OPERATIVAS EN EL MANUAL DEL PROPIETARIO.

DATE OF MANUFACTURE: 2020 2021 2022 2023 2024 2025 2026  
DATE DE FABRIQATION: Jan Feb Mar Apr May Jun Jul Aug Sep Oct Nov Dec  
FECHA DE FABRIQACION: [ ] [ ] [ ] [ ] [ ] [ ] [ ] [ ] [ ] [ ] [ ] [ ]

75-22-002 2/19

254 mm

## High Efficiency Wood Stove - Medium



### Model Series:

**PH1800WS, MWS-1800, WSL-1800-B,  
WSL-1800, GWS-1800, GWS-1800-B**

**SAFETY NOTICE: IF THIS WOOD BURNING APPLIANCE IS NOT PROPERLY INSTALLED, OPERATED, AND MAINTAINED, A HOUSE FIRE MAY RESULT. TO REDUCE THE RISK OF FIRE, FOLLOW THE INSTALLATION INSTRUCTIONS. FAILURE TO FOLLOW THE INSTALLATION INSTRUCTIONS MAY RESULT IN PROPERTY DAMAGE, BODILY INJURY OR EVEN DEATH. CONTACT LOCAL BUILDING OFFICIALS ABOUT RESTRICTIONS AND INSTALLATION INSPECTION REQUIREMENTS IN YOUR AREA.**

### **WARNING**

BEFORE LIGHTING YOUR FIRST FIRE, REMOVE PLASTIC FILM OFF TRIM AND CLEAN THE PLATED SURFACES WITH DENATURED ALCOHOL OR A GOOD QUALITY, NON-ABRASIVE LIQUID GLASS CLEANER. APPLY WITH A VERY SOFT, CLEAN CLOTH. DO NOT USE PAPER TOWELS TO CLEAN THE PLATED PARTS. FAILURE TO CLEAN ALL MARKS AND FINGERPRINTS FROM THE PLATED SURFACES WILL CAUSE PERMANENT DAMAGE.

NOTE: Some states and provinces do not allow the exclusion or limitation of incidental or consequential damages. The above limitations may not apply to you.

This manual describes the installation and operation of the Models PH1800WS, MWS-1800, WSL-1800-B, WSL-1800, GWS-1800, GWS-1800-B non-catalytic wood heater.

US Environmental Protection agency certified to comply with 2020 particulate emissions standards using cordwood. Please read this entire manual before you install and use your new room heater.

This Stove is listed by OMNI-Test Laboratories of Portland, Oregon using Test Method ASTM 25155 and ASTM 3053 and Tested to UL-1482-11 (R2015)/ULC-S627-00

**6" Flue  
required**



**Do Not Discard This Manual: Retain for Future Use**

Questions, problems, missing parts? Before returning to your retailer, call our customer service department at 877-447-4768 8:30 a.m. - 4:30 p.m. CST, Monday - Friday or e-mail us at [customerservice@ghpgroupinc.com](mailto:customerservice@ghpgroupinc.com).



REPORT NO.  
0418WS017S/0418WS017E  
60-10-040  
2020-02-26

## CAUTION

After reading these instructions, if you have any doubt about your ability to complete your installation in a professional like manner you should obtain the services of an installer versed in all aspects as to the correct and safe installation. Do not use temporary makeshift compromises during installation.

### BEFORE INSTALLATION OF YOUR APPLIANCE

1. Check with the building inspector's office for compliance with local codes; a permit may be required.
2. The room heater must be connected to 1) a chimney complying with the requirements for Type HT chimneys in the standard for Chimneys, Factory-Built, Residential Type and Building Heating Appliance, UL 103, or in Canada CAN/ULC-S629 Standard for 650 degree C Factory Built Chimneys and applicable building codes or 2) a code-approved masonry chimney with a flue liner.
3. A 6" (152mm) diameter, 24 gauge Black Steel flue is required for proper performance.
4. Always connect this unit to a chimney and NEVER vent to another room or inside a building.
5. DO NOT connect this unit to any duct work to which another appliance is connected such as a furnace.
6. **DO NOT CONNECT THIS UNIT TO A CHIMNEY FLUE SERVING ANOTHER APPLIANCE.**
7. The connector pipe and chimney should be inspected periodically and cleaned if necessary.
8. Remember the clearance distances when you place furniture or other objects within the area. **DO NOT** store wood, flammable liquids or other combustible materials too close to the unit.

**Refer to certification label on back of your unit for required clearances.**

9. Contact your local municipal or provincial fire authority for information on how to handle a chimney fire. Have a clearly understood plan to handle a chimney fire. In the event of a Chimney fire, turn air control to closed position and **CALL THE FIRE DEPARTMENT.**
10. **DO NOT** tamper with combustion air control beyond normal adjustment.
11. **DO NOT INSTALL THESE UNITS IN A MOBILE HOME OR TRAILER. THESE UNITS ARE NOT MOBILE HOME APPROVED.**
12. **DO NOT CONNECT TO ANY AIR DISTRIBUTION DUCT OR SYSTEM.**
13. When installing a solid fuel appliance, it is also recommended to install Smoke and Carbon Monoxide Detectors on every level of the house. During the initial firing of the appliance, some smoke or odor may occur due to paint curing. You may want to keep some windows open for ventilation during the first few hours of burning to prevent smoke detector activation. Test your smoke and carbon monoxide detectors regularly.

## OPERATION

### WHY THE CORRECT FLUE SIZE IS IMPORTANT - 6"

Draft is the force which moves air from the appliance up through the chimney. The amount of draft in your chimney depends on the length of the chimney, local geography,

nearby obstructions, and other factors. Too much draft may cause excessive temperatures in the appliance. An uncontrolled burn or a glowing red part or chimney connector indicates excessive draft. Inadequate draft may cause back puffing into the room and "plugging" of the chimney and/or cause the appliance to leak smoke into the room through appliance and chimney connector joints.

Today's solid fuel appliances are more efficient than in the past. The units are designed to give you controlled combustion, and maximum heat transfer, using less fuel to do so. The design of your new appliance is such that the exhaust smoke is now at lower temperatures than in the past, therefore requiring proper chimney size to give adequate draft. If your chimney is too large, the heating appliance will have a difficult time to raise the chimney flue temperature to give adequate draft, therefore causing a smoke back up, poor burn, or both.

### Should you experience such a problem call in a local chimney expert.

With the door closed, the rate of burning is regulated by the amount of air allowed to enter the unit through the air control. With experience you will be able to set the control for heat and burning time desired.

Once the required chimney draft is obtained, operate only with doors closed and open doors slowly when re-fueling. (This will reduce or eliminate smoke from entering the room). Attempts to achieve higher output rates that exceed heater design specifications can result in permanent damage to the heater. The recommended wood load is level with the top of the firebricks.

Overloading may prevent sufficient air entering the heater to properly fuel the fire.

Operate this heater only with the door closed.

**DO NOT BURN GARBAGE OR FLAMMABLE FLUIDS, SUCH AS GASOLINE, NAPHTHA, OR ENGINE OIL DO NOT USE CHEMICALS OR FLUIDS TO START THE FIRE.**

ALWAYS PROVIDE A SOURCE OF FRESH AIR INTO THE ROOM WHERE THE UNIT IS INSTALLED. FAILURE TO DO SO MAY RESULT IN AIR STARVATION OF OTHER FUEL BURNING APPLIANCES AND THE POSSIBLE DEVELOPMENT OF HAZARDOUS CONDITIONS.

**HOT WHILE IN OPERATION. KEEP CHILDREN, CLOTHING AND FURNITURE AWAY. CONTACT MAY CAUSE SKIN BURNS.**

OPTIONAL BLOWER: MODEL PBAR-2427, 120 VOLTS, 60Hz, 1.0 AMPS, 2900 RPM  
**DANGER:** RISK OF ELECTRIC SHOCK. DISCONNECT POWER BEFORE SERVICING UNIT.  
**IMPORTANT:** FOR OPTIMUM HEATER PERFORMANCE AT LOW BURN RATE, OPERATE THE FAN AT LOW SPEED.

**IMPORTANT:** It is highly recommended that the wood stove and chimney be installed by a qualified installer. (A qualified installer is a person or entity who regularly installs wood heating products and chimneys, in the ordinary course of their regular business.)



**⚠ WARNING**

This product and the fuels used to operate this product (charcoal or wood), and the products of combustion of such fuels, can expose you to chemicals including carbon black, which is known to the State of California to cause cancer, and carbon monoxide, which is known to the State of California to cause birth defects or other reproductive harm. For more information go to [www.p65Warnings.ca.gov](http://www.p65Warnings.ca.gov)

**Leg Installation (If required)**

**Before Installing Stove, Follow These Steps for leg Installation.**

**Model: PH1800WS, MWS-1800, WSL-1800-B, WSL-1800, GWS-1800, GWS-1800-B  
Medium Wood Stove w/Legs**

Remove Ash pan and (4) bolts that secure the stove body to the pedestal as shown in Figure 0.

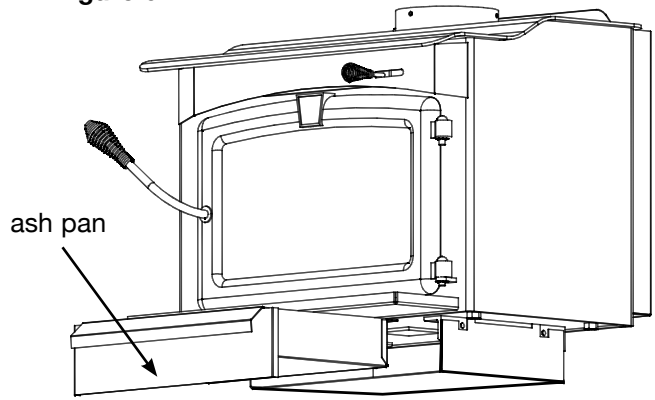
With assistance, lift stove off of pallet and lay stove on its side on a safe, elevated, padded and level platform that is about 6" off the ground.

Using the bolts that were removed in step 1, bolt each leg to the bottom of the stove as shown in Figure 0.1.

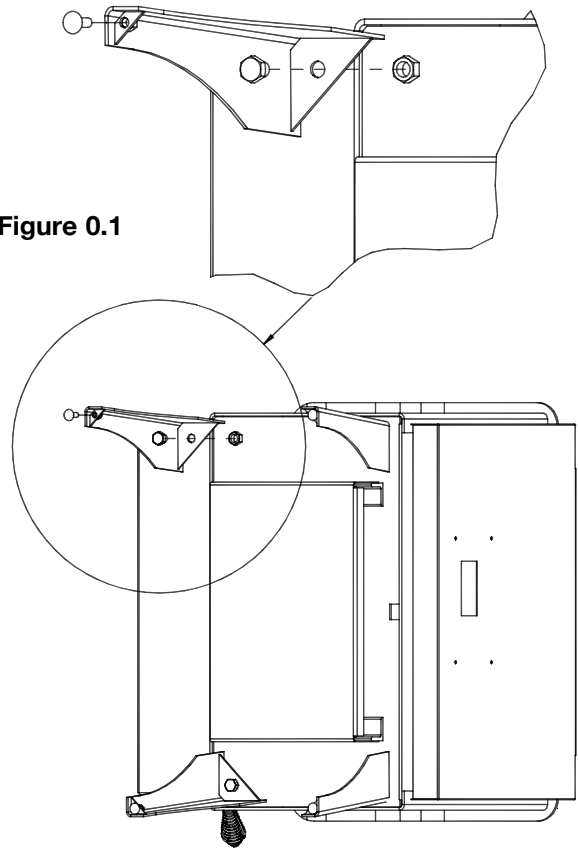
With assistance, lift the stove off of the raised platform, set upright on the legs, and re-install the ash pan.

When stove is in place for installation, make sure stove is level by adjusting the leg levelers shown in Figure 0.2.

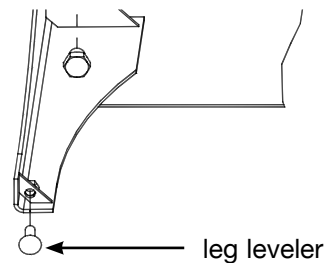
**Figure 0**



**Figure 0.1**

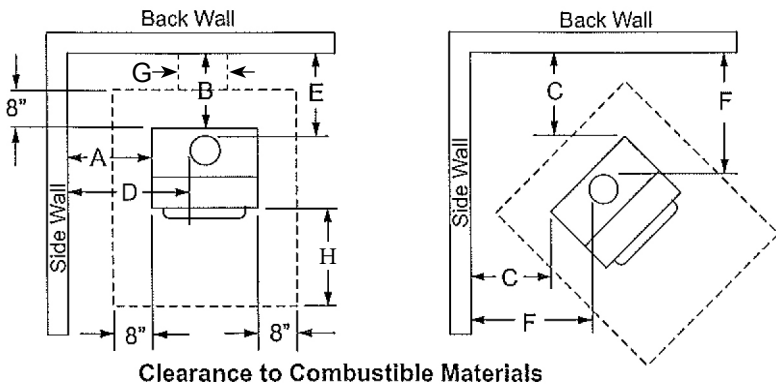


**Figure 0.2**



**Figure 1**

**Clearance from Combustible Materials**



A larger clearance to the chimney connector may be required by the authority having jurisdiction.

**From Heater**

A. Sidewall 25" (635 mm)

B. Back Wall 19" (483 mm)

C. Corner 16" (407 mm)

**From Chimney Connector**

D. Sidewall 34" (864 mm)

E. Back Wall 22" (559 mm)

F. Corner 25" (635mm)

Minimum height from floor to ceiling. 96" (2.44 m)

G = 4" (102 mm) greater than the pipe diameter when pipe exits through rear wall.

H = 22" (559 mm)

**INSTALLATION**

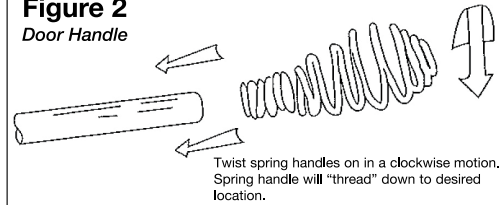
Contact your local building inspector prior to installation. A permit may be required in your area.

1. Remove all parts from inside the stove body.
2. Select the proper location for the stove. These appliances must not be installed any closer than the minimum clearance to combustible materials shown in Brick pattern (Figure 1). The stove must be installed on a non combustible surface as shown in Figure 1.
3. If noncombustible materials have been installed on the walls, obtain the minimum clearances from either the manufacturer of these materials or the local building inspectors office.
4. Install the stovepipe INSIDE the flue collar on the top of the stove between the stove and chimney.
5. DO NOT use a grate to elevate the fire.

This wood heater has a manufacturer-set minimum low burn rate that must not be altered. It is against federal regulations to alter this setting or otherwise operate this wood heater in a manner inconsistent with operating instructions in this manual.

**Figure 2**

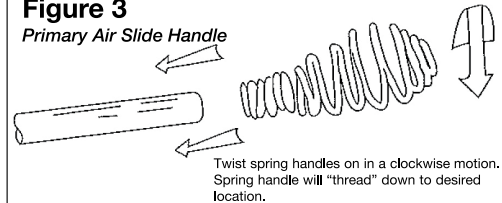
**Door Handle**



Twist spring handles on in a clockwise motion. Spring handle will "thread" down to desired location.

**Figure 3**

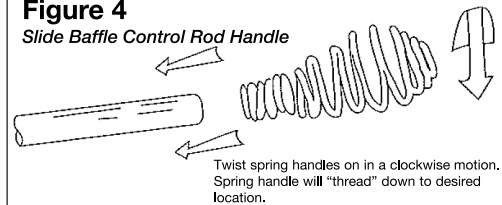
**Primary Air Slide Handle**



Twist spring handles on in a clockwise motion. Spring handle will "thread" down to desired location.

**Figure 4**

**Slide Baffle Control Rod Handle**



Twist spring handles on in a clockwise motion. Spring handle will "thread" down to desired location.

**STOVE PIPE**

1. A larger clearance between the stovepipe and combustible materials may be required. Check with authorities having jurisdiction in your area.
2. All pipe sections must be connected with the male end (crimped end) toward the stove.
3. Fasten the stove pipe to the flue collar by the use of three sheet metal screws. Do the same at each additional joint to make the entire installation rigid.
4. Maintain the required diameter flue for the entire installation.
5. If you are connecting the stove to an old masonry flue, be sure to have it inspected for cracks and general condition. Resizing with a stainless steel liner may be required.
6. It is recommended that no more than two (2) 90° bends be used in the stove pipe installation. More than two (2) 90° bends may decrease the amount of draw and possibly cause smoke spillage.
7. A damper is not required in this installation. Remove damper plate in the chimney or secure in OPEN position.
8. Single wall flue pipe assemblies must not exceed 10 feet (3 m) in overall length.

**CAUTION: DO NOT** open fire-door to a point where it would be in contact with the combustible sidewall.

**CAUTION:** Brick for ash drawer must be installed before operation of wood heater.

**Optional Fan** - An optional heat exchange blower is available for this wood burning appliance. To order please see the local dealer where you purchased the appliance.





## FLOOR PROTECTION

### INSTALLATION ON A CONCRETE FLOOR

An appliance installed on a concrete floor does not require floor protection. If carpeting or any other combustible floor covering is installed, a clearance around the stove must be maintained equivalent to the size of the floor protector described in the following section.

### INSTALLATION ON A COMBUSTIBLE FLOOR

If the appliance is to be installed on a combustible floor or floor covering, a **floor protector** must be inserted under the stove and project beyond the front of the stove a minimum of 22" (559mm) and 8" (203mm) on all other sides. In the US the **floor protector** must also be positioned under any horizontal chimney run and project beyond the pipe a minimum of 2" (51mm) on both sides. The **floor protector** must be a durable noncombustible material with a minimum thickness of 0.5" and an R value of "1.06".

To determine a material's suitability use the following formulas;

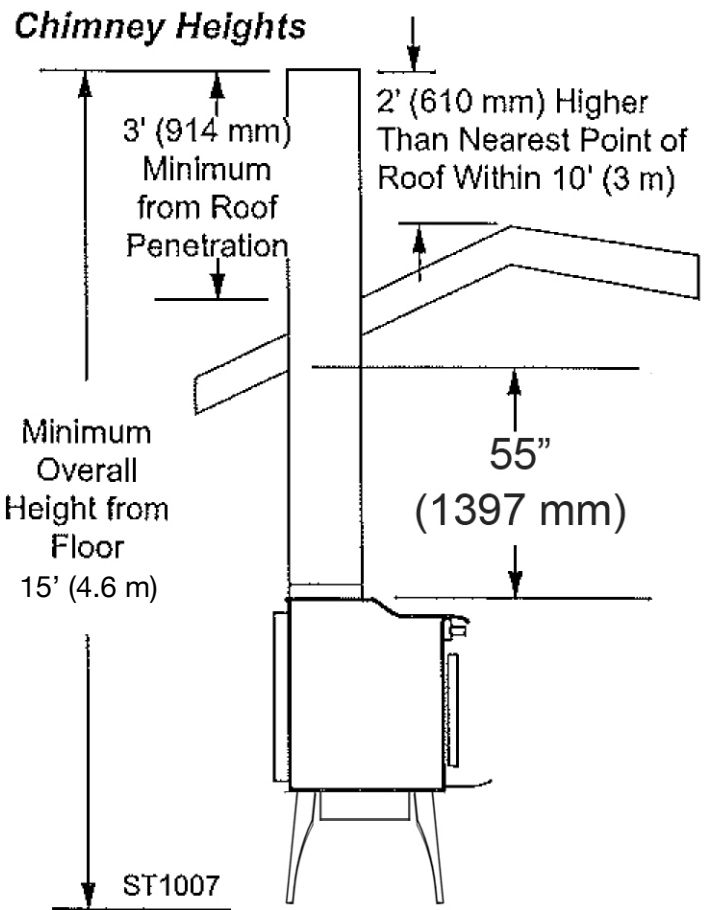
1. If the material has an R (Thermal resistance) rating use the designated thickness and no conversion is needed. R values can be added for multi-layered materials.
2. If the material has a k (Thermal conductivity) rating convert this to an R rating using the formula  $R = 1/k \times t$  (t = thickness in inches)
3. If the material has a C (Thermal conductance) rating convert this to an R rating using the formula  $R = 1/C$ .

## CHIMNEY

### CONTACT YOUR LOCAL BUILDING AUTHORITY FOR APPROVED METHODS OF INSTALLATION

1. This appliance requires a masonry or pre-manufactured chimney listed to CAN/ULC-S629 (Canada) and UL103HT (USA) sized correctly.
2. If a masonry chimney is used it is advisable to have your chimney inspected for cracks and check the general condition before you install your unit. Relining may be required to reduce flue diameter to the appropriate functional size.
3. To help ensure a good draft, the top of the chimney should be at least 3 feet (914mm) above the point of penetration through the roof, and be at least 2 (610mm) feet higher than any point of the roof within 10 feet (3M).
4. The chimney connector shall not pass through an attic, roof space, closet, concealed space, floor, ceiling, wall, or any partition of combustible construction.
5. The minimum overall height of your chimney should be 15 feet (5 m) from the floor (Figure 3).
6. Do not use makeshift compromises during installation.

Figure 3



### REFER TO CHIMNEY MANUFACTURER'S INSTRUCTIONS FLUE DRAFT CONSIDERATIONS

Location of the appliance and chimney will affect performance. The chimney should:

- Penetrate the highest part of the roof. This minimizes the affects of wind turbulence and down drafts.
- Consider the appliance location in order to avoid floor and ceiling attic joists and rafters.

Exterior conditions such as roof line, surrounding trees, prevailing winds and nearby hills can influence stove performance. Your local dealer is the expert in your geographic area and can usually make suggestions or discover solutions that will easily correct your flue problem.

NOTE: These are guidelines only, and may vary somewhat for individual installations.

**IMPORTANT:** It is highly recommended that the wood stove and chimney be installed by a qualified installer. (A qualified installer is a person or entity who regularly installs wood heating products and chimneys, in the ordinary course of their regular business.)

## VENTING SYSTEMS

The venting system consists of a chimney connector (also known as stove pipe) and a chimney. These get extremely hot during use. Temperatures inside the chimney may exceed 2000°F (1100°C) in the event of a creosote fire. To protect against the possibility of a house fire, the chimney connector and chimney **must be properly installed and maintained**. An approved thimble must be used when a connection is made through a combustible wall to a chimney. A chimney support package must be used when a connection is made through the ceiling to a prefabricated chimney. These accessories are **absolutely necessary** to provide safe clearances to combustible wall and ceiling material. Follow venting manufacturer's clearances when installing venting system.

## TOOLS AND SUPPLIES NEEDED

Before beginning the installation be sure that the following tools and building supplies are available.

Reciprocating saw	Framing Material
Pliers	Hi-Temp Caulking Material
Hammer	Gloves
Phillips Head Screwdriver	Framing Square
Flat Blade Screwdriver	Electric Drill & Bits (1/4")
Plumb Line	Safety Glasses
Level	1/2 in. - 1/4 in. length, #6 or
Tape Measure	#8 self drilling screws (need per pipe section connection)

## INSPECT APPLIANCE & COMPONENTS AND PRE-USE CHECK LIST

1.	Place the appliance in a location near the final installation area and follow the procedures below:
2.	Open the appliance and remove all the parts and articles packed inside the Component Pack. Inspect all the parts and glass for shipping damage. Contact your dealer if any irregularities are noticed.
3.	All safety warnings have been read and followed.
4.	This Owner's Manual has been read.
5.	Floor protection requirements have been met.
6.	Venting is properly installed.
7.	The proper clearances from the appliance and chimney to combustible materials have been met.
8.	The masonry chimney is inspected by a professional and is clean, or the factory built metal chimney is installed according to manufacturer's instructions and clearances.
9.	The chimney meets the required minimum height.
10.	All labels have been removed from the glass door.
11.	A power outlet is available nearby if installing optional blower assembly.

### WARNING

#### Asphyxiation Risk.

- Do NOT connect this unit to a chimney flue servicing another appliance.
  - Do NOT connect to any air distribution duct or system.
- May allow flue gases to enter the house.

### WARNING

#### Fire Risk.

- Inspect appliance and components for damage. Damaged parts may impair safe operation.
- Do NOT install damaged components.
  - Do NOT install incomplete components.
  - Do NOT install substitute components.
- Report damaged parts to dealer.

### Typical Stove Systems

Stove system with masonry chimney consists of:

- Stove
- Chimney Connector (stove pipe)
- Thimble
- Masonry Chimney
- Hearth Pad Floor Protection

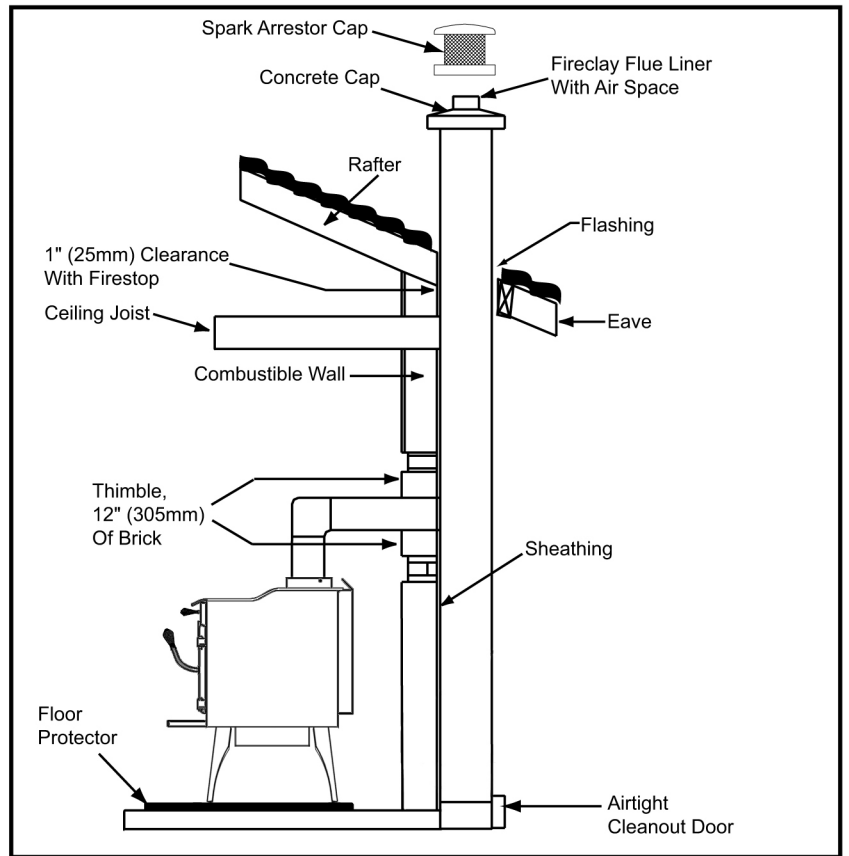


Figure 4.1 Masonry Chimney

Stove system with prefabricated metal chimney consists of:

- Stove
- Chimney Connector (stove pipe)
- Thimble (for exterior chimney)
- Firestops
- Insulations Shields
- Storm Collar and Flashing
- Termination Cap
- Hearth Pad Floor Protection

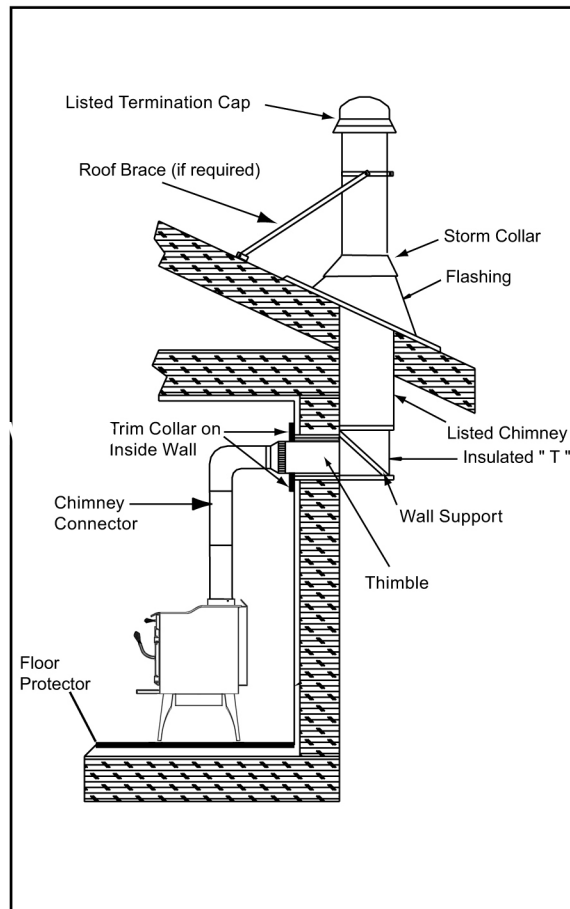


Figure 4.2 Exterior Prefabricated Chimney

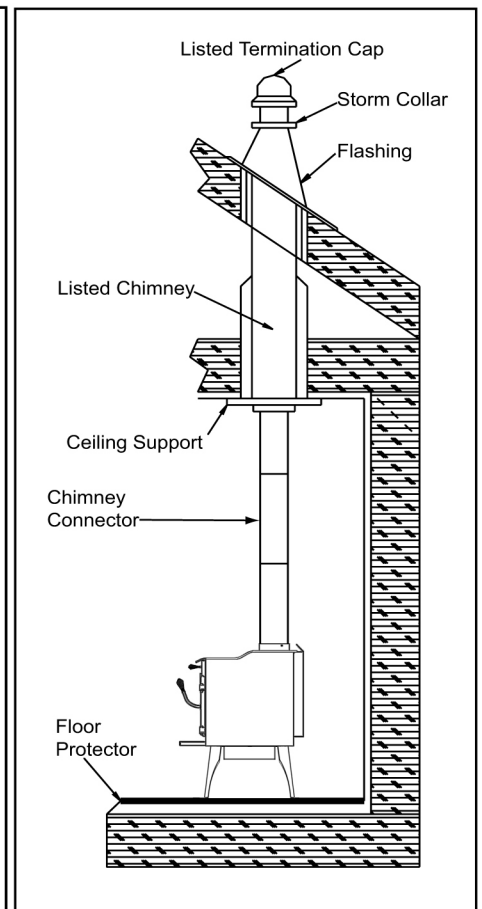


Figure 4.3 Interior Prefab. Chimney

# CHIMNEY REQUIREMENTS

## Typical Stove Systems

Stove system with masonry chimney consists of:

- Stove
- Chimney Connector (stove pipe)
- Thimble
- Masonry Chimney
- Hearth Pad Floor Protection

Stove system with prefabricated metal chimney consists of:

- Stove
- Chimney Connector (stove pipe)
- Thimble (for exterior chimney)
- Firestops
- Insulations Shields
- Storm Collar and Flashing
- Termination Cap
- Hearth Pad Floor Protection

**NOTE:** In Canada when using a factory-built chimney it must be safety listed, **Type UL103 HT (2100°F) CLASS "A"** or conforming to **CAN/ULC-S629, STANDARD FOR 650°C FACTORY-BUILT CHIMNEYS.**

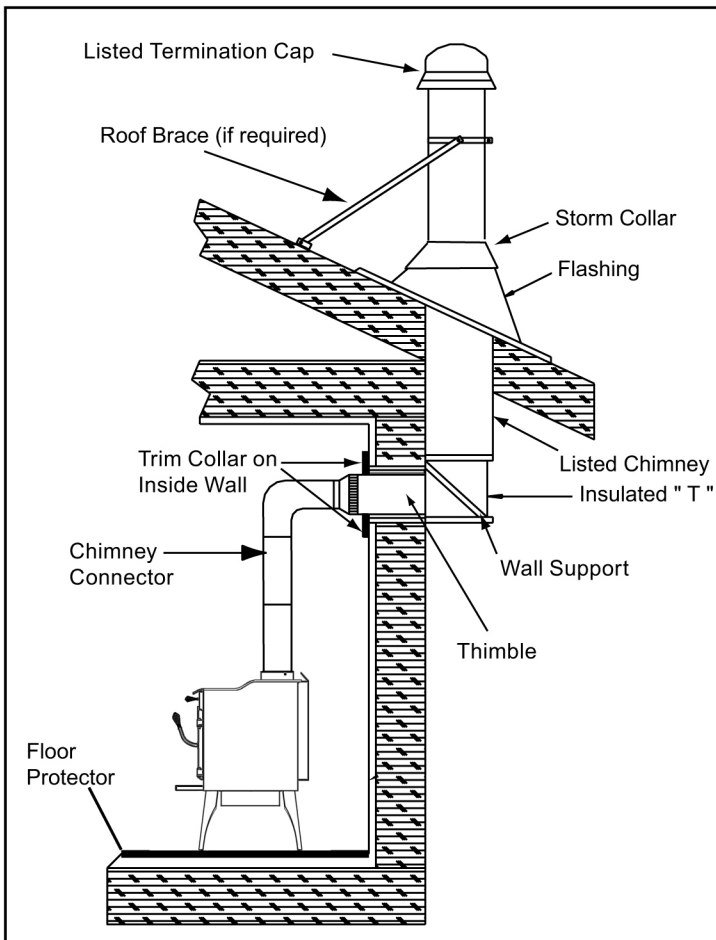


Figure 5.1 Prefabricated Exterior Chimney

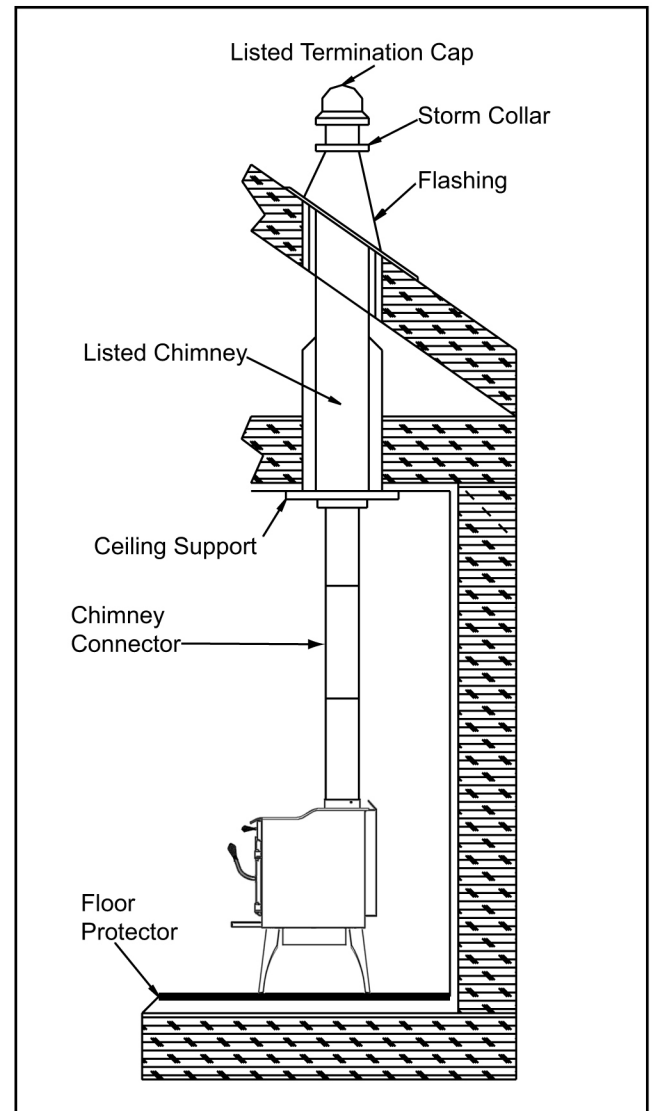


Figure 5.2 Prefabricated Interior Chimney

## VENTING COMPONENTS

### Chimney Connector:

It is also known as flue pipe or stove pipe. The chimney connector joins the stove to the chimney. It must be a 6 inch (152mm) minimum diameter 24 gauge mild steel black steel, or an approved air-insulated double wall venting pipe.

### Thimble:

A manufactured or site-constructed device installed in combustible walls through which the chimney connector passes to the chimney. It is intended to keep the walls from igniting. Site constructed thimbles must meet NFPA 211 Standards. Prefabricated must be suitable for use with selected chimney and meet UL103 Type HT Standards. Follow instructions provided by the manufacturer for manufactured thimbles for masonry chimney and prefabricated chimneys.

### Chimney:

The chimney can be new or existing, masonry or prefabricated and must meet the following minimum requirements specified in Section 5B.B.

## CHIMNEY SYSTEMS

### Prefabricated Metal Chimney

- Must be a 6 inch (152mm) diameter (ID) high temperature chimney listed to UL 103HT (2100°F) or ULC S627.
- Must use components required by the manufacturer for installation.
- Must maintain clearances required by the manufacturer for installation.
- Refer to manufacturers instructions for installation.

### Thimble

Site constructed for masonry chimney installation:

### Components

- A minimum length of 12 inches [05mm] (longer for thicker walls) of solid insulated factory-built chimney length constructed to UL 103 Type HT 6 inch (152mm) inside diameter. Chimney needs to extend a minimum of 2 inches (51mm) from the interior wall and a minimum of 1 inch (25mm) from the exterior wall.
- Wall spacer, trim collar and wall band to fit solid pack chimney selected.
- Minimum 8 inch (20mm) diameter clay liner section (if not already present in chimney) and refractory mortar.

### Air Clearances

- Masonry chimney clearance must meet NFPA 211 minimum requirement of 2 inches (51mm) to sheet metal supports and combustibles.
- Minimum of 1 inch (25mm) clearance around the chimney connector.

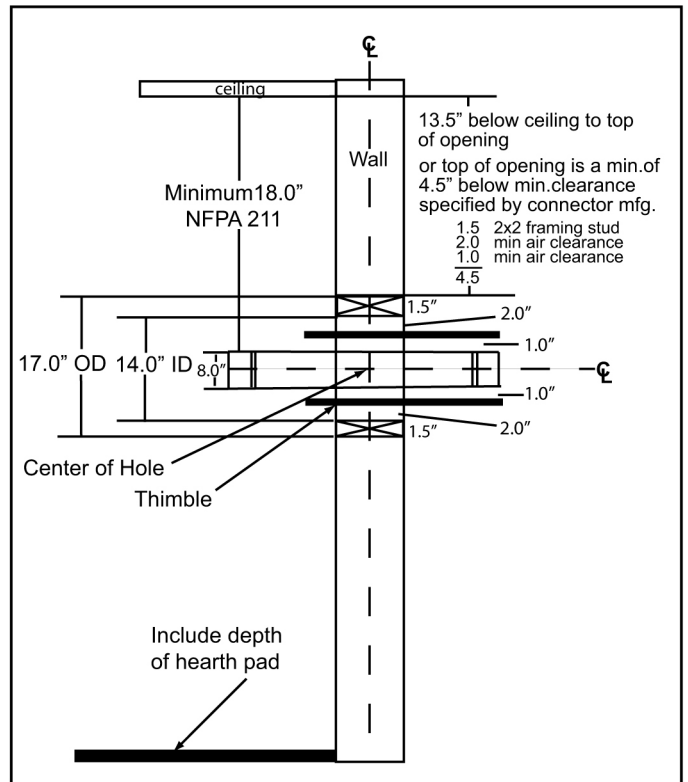


Figure 6.1

### Solid Pack Chimney with Metal Supports as a Thimble

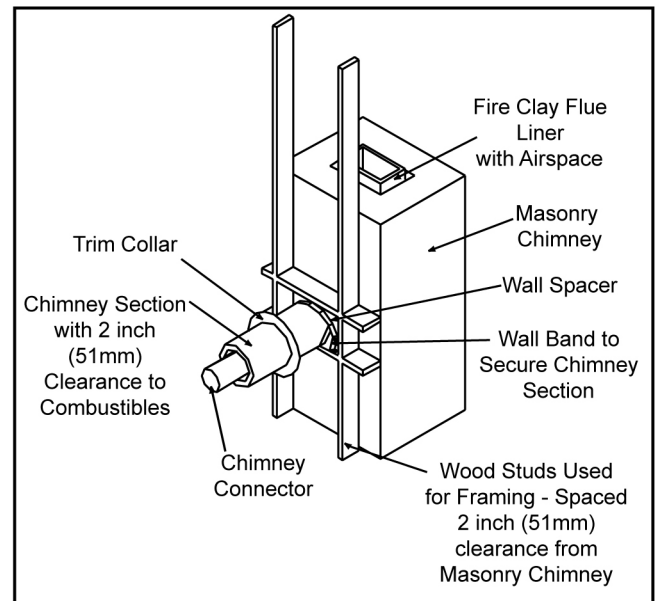


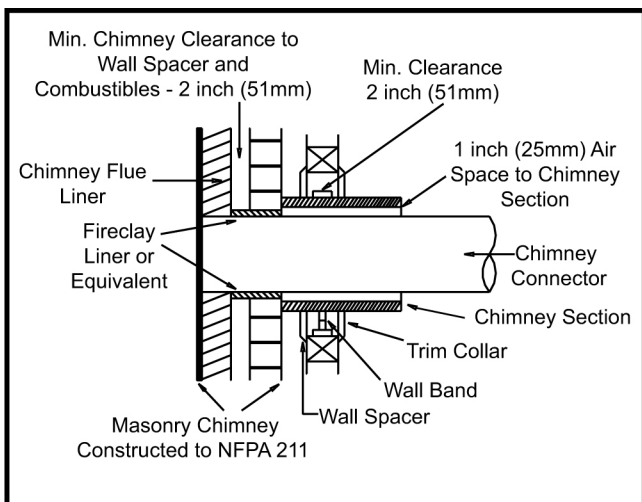
Figure 7.1

## WARNING

### Fire Risk.

- Do NOT pack insulation or other combustibles between spacers.
- ALWAYS maintain specified clearances around venting and spacers.
  - Install spacers as specified.
- Failure to keep insulation or other material away from vent pipe may cause fire.

- Top of wall opening is a minimum of 1-1/2 inches (4mm) from ceiling or 4-1/2 inches (114mm) below



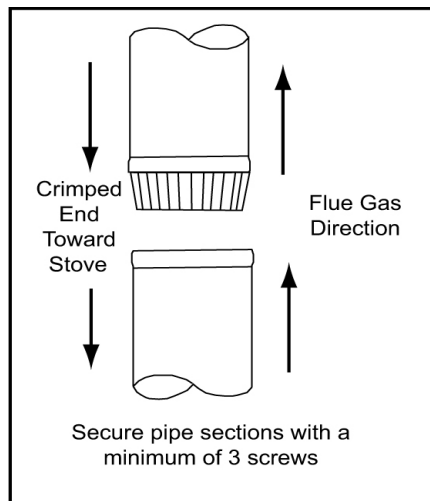
**Figure 7.2**

minimum clearance specified by chimney connector manufacturer. NFPA 211 minimum vertical clearance of 18 inches (457mm) from chimney connector and ceiling or minimum recommended by chimney connector manufacturer. **Figure 6.1.**

**Instructions:**

1. Open inside wall at proper height for the chimney connector to entry the masonry chimney. **Figure 6.1.**
2. Entry hole to masonry chimney must be lined with an 8 inch (20mm) minimum diameter clay liner, or equivalent, secured with refractory mortar.
3. Construct a 17 inch x 17 inch (42mm x 42mm) outside dimension frame from 2 x 2 framing lumber to fit into wall opening. Inside opening of frame should be no

- less than 14 inch x 14 inch (56mm x 56mm). **Figure 6.1.**
4. Attach the wall spacer to the chimney side of the frame.
5. Nail the frame into the wall opening. The spacer should be on the chimney side.
6. Insert the section of the solid insulated chimney into the outer wall of the masonry chimney.
7. Tightly secure the length of the solid insulated chimney with the wall band to the masonry chimney.
8. Insert a section of chimney connector into the chimney. Make sure it does not protrude past the edge of the clay chimney liner inside the chimney.



**Figure 8**

**WARNING**

**Fire Risk.**

Inspection of Chimney:

- Chimney must be in good condition.
- Meets minimum standard of NFPA 211
- Factory-built chimney must be 6 inch (152mm) UL103HT.

**WARNING**

**Fire Risk.**

Follow Chimney Connector Manufacturer's Instructions for Proper Installation.

ONLY use connector:

- Within the room, between appliance and ceiling or wall.

Connector shall NOT pass through:

- Attic or roof space
- Closet or similar concealed space
- Floor or ceiling

Maintain minimum clearances to combustibles

**WARNING**

**Asphyxiation Risk.**

- Do NOT connect this unit to a chimney flue servicing another appliance.
- Do NOT connect to any air distribution duct or system.

May allow flue gases to enter the house.

**WARNING**

Improper installation, adjustment, alteration, service or maintenance can cause injury or property damage. Refer to the owner's information manual provided with this appliance. For assistance or additional information consult a qualified installer, service agency or your dealer.

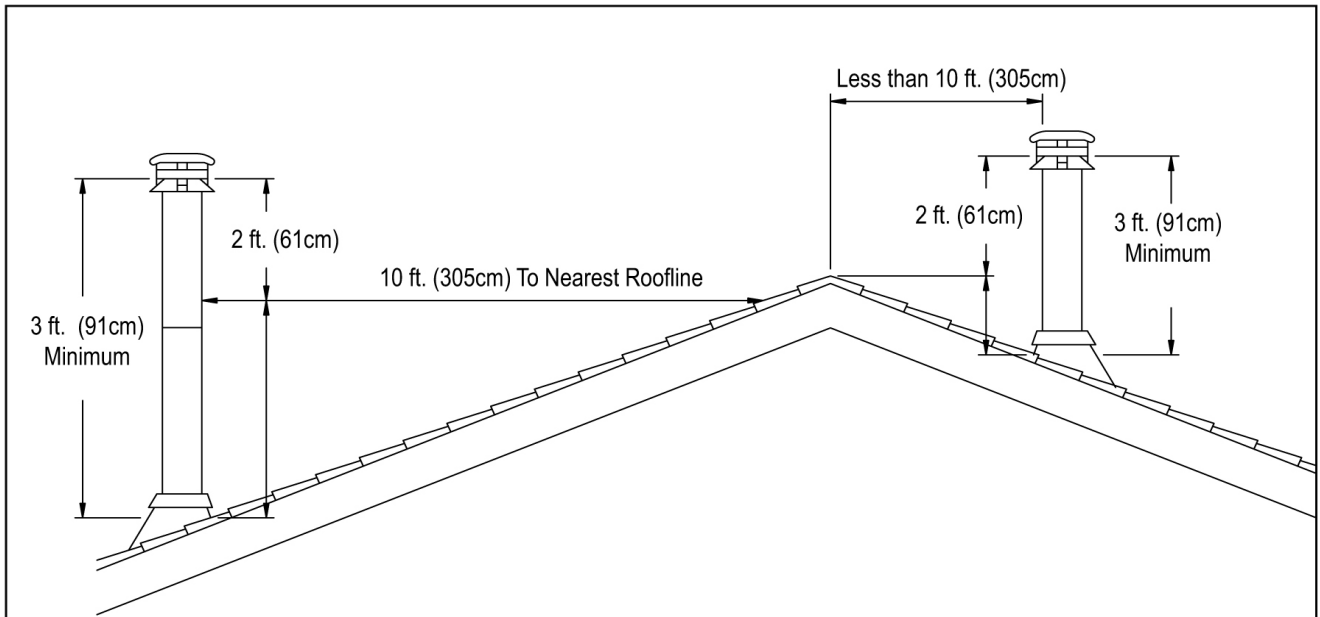
9. Seal the end of the chimney connector to the clay liner with refractory mortar.

10. Install trim collar around the solid pack chimney section.

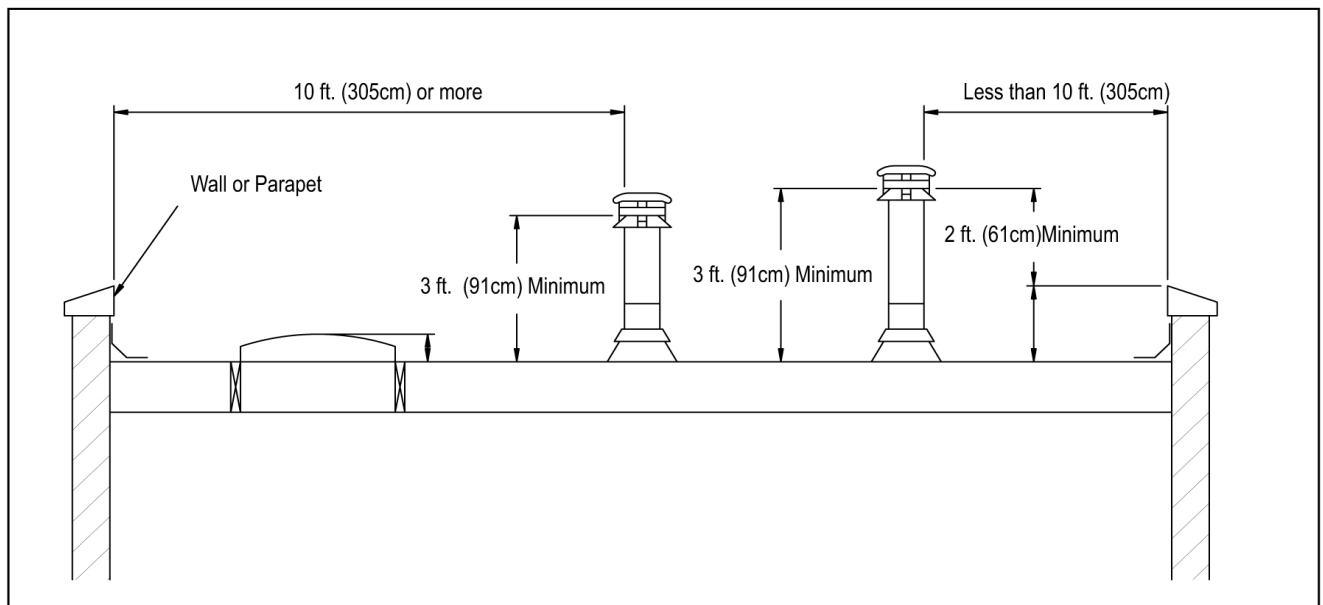
**Solid Pack Chimney with Metal Supports as a Thimble (Cont'd)**

**NOTE:**

- Chimney performance may vary.
- Trees, buildings, roof lines and wind conditions affect performance.
- Chimney height may need adjustment if smoking or overdraft occurs.



Pitched Roof

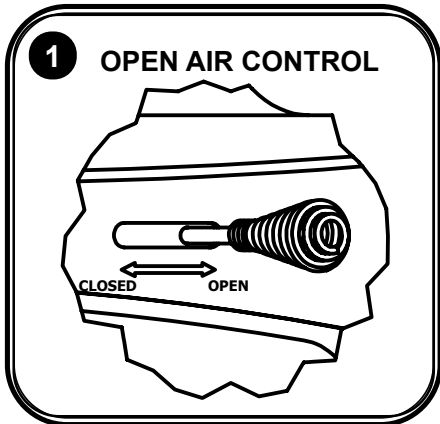


Flat Roof

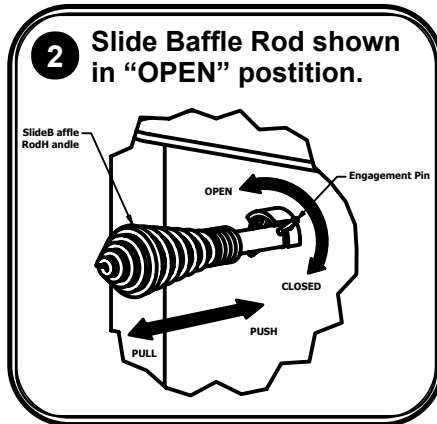
# WOOD STOVE QUICK START GUIDE

## ITEMS NEEDED FOR START-UP FIRE:

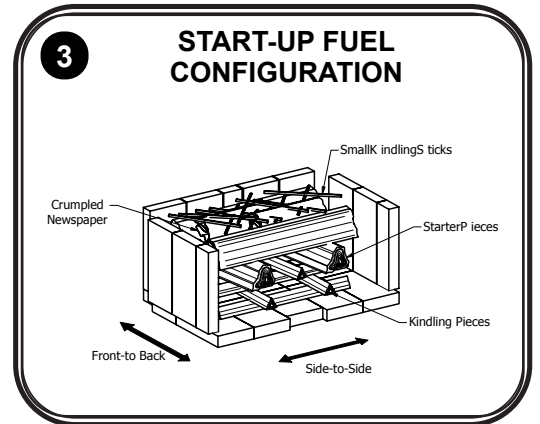
- 5 Wadded Up Pieces of Newspaper
- 8 Pieces of Dry Kindling
- 4 Pieces of Seasoned Split Wood
- 1/2 lb of Small Dry Kindling



Slide damper control all the way to the right to completely open the damper.

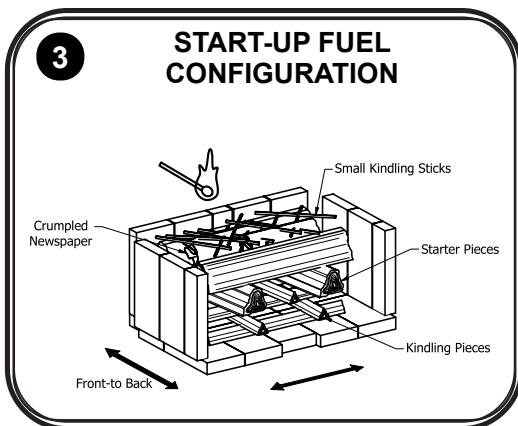


Pull Rod Handle out to rotate between "CLOSED" and "OPEN" position. "PUSH" Rod Handle in to lock in position.

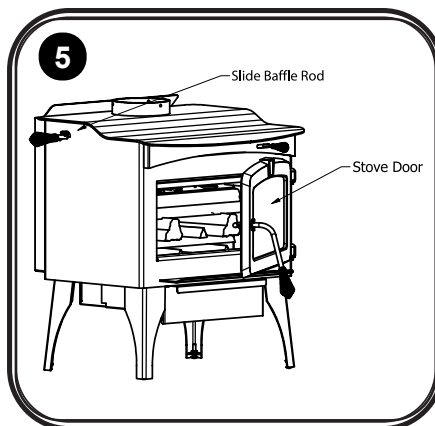


Configure the Fuel in Six Layers as Follows:

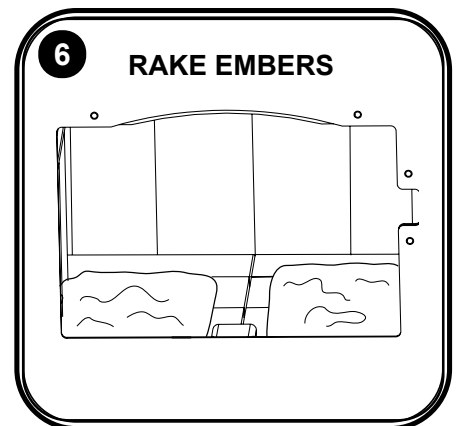
1. Position two kindling pieces side to side
2. Position two kindling pieces front to back
3. Position two kindling pieces side to side
4. Position two larger starter pieces front to back and one kindling piece between the starter pieces front to back
5. Position two larger starter pieces side to side and one kindling piece between the starter pieces side to side
6. Add crumpled newspaper and 1/2 lb. of small kindling sticks as the top layer.



Light the newspaper and small kindling sticks with a match



1. Leave the door open 12 in. and allow the start-up fuel to burn until the kindling and starter pieces are burning
2. Close the door and slide baffle rod and allow the fire to burn until there is a layer of coals over the bottom of the stove



1. Open the Slide Baffle Rod per Step 2
2. Open the Door
3. Rake Embers to create a level bed on the bottom of stove.

Questions, problems, missing parts? Before returning to your retailer, call our customer service department at 877-447-4768 8:30 a.m. – 4:30 pm CST, Monday – Friday. or email us at [customerservice@ghpgroupinc.com](mailto:customerservice@ghpgroupinc.com)

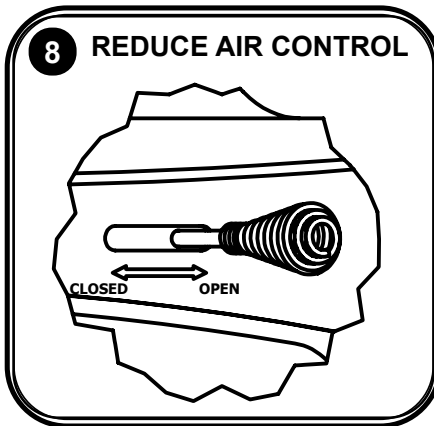
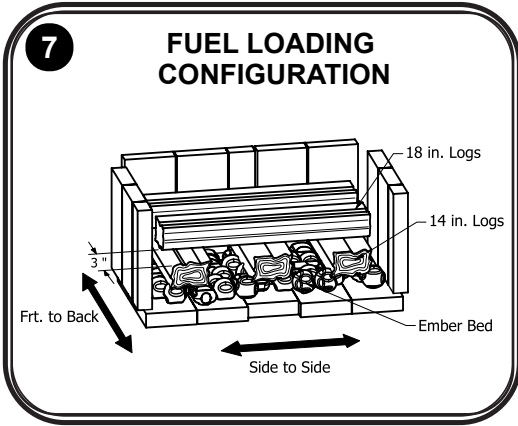




# WOOD STOVE QUICK START GUIDE

## ITEMS NEEDED FOR FIRST FIRE:

- 3 Pieces of Seasoned Split Wood 14 in. Long
- 2 Pieces of Seasoned Split Wood 18 in. Long

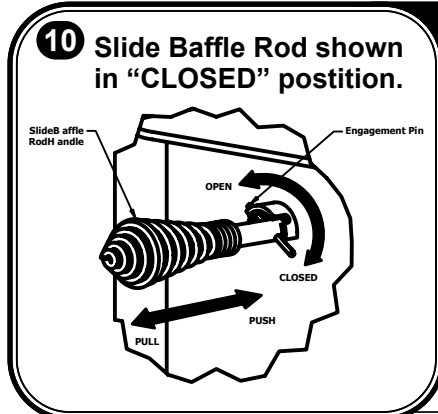


Configure the Fuel as Follows:

1. Position 3 logs approximately 12-14 inches long front to back with gaps between the pieces on top of the ember bed
2. Position 2 logs approximately 18 in. long side to side on top of the first layer with the front log back approximately 3 inches from the first layer logs

Slide damper control to desired setting, and leave stove door open 12 inches for one minute.

Once fire is fully burning, fully close and latch stove door.



## WARNING! Risk of Fire

Always OPEN the Slide Baffle before opening the door to refuel the stove! This will prevent:

- Spillage of smoke, flame and carbon monoxide
- Spillage of sparks, coals and logs
- Over-firing

Insure the slide baffle is in the CLOSED position after the Door is closed to activate the Efficiency and Fuel Saving design of this stove.

DO NOT leave the stove unattended with the door open.

Starting a fire may not require an open door to draft. The air control should supply adequate draft.

Pull Rod Handle out to rotate between "CLOSED" and "OPEN" position. "PUSH" Rod Handle in to lock in position. **Congratulations! Your wood stove is ready for operation.**

This wood heater needs periodic inspection and repair for proper operation. It is against federal regulations to operate this wood heater in a manner inconsistent with operating instructions in this manual.

## Efficiency, Heat Output, and Particulate Emissions:

The Weighted Average HHV Efficiency = 70.1%

The Sum of Weighted Particulate Emission = 2.18 grams/hour

Heat Output Range = 17,349 to 62,789 BTU/hour

Questions, problems, missing parts? Before returning to your retailer, call our customer service department at 877-447-4768 8:30 a.m. – 4:30 pm CST, Monday – Friday. or email us at [customerservice@ghpgroupinc.com](mailto:customerservice@ghpgroupinc.com)

## Chimney Height / Rise and Run

This product was designed for and tested on a 6 inch (152mm) chimney, 14 to 16 feet (420-480cm) high, (includes stove height) measured from the base of the appliance. The further your stack height or diameter varies from this configuration, the possibility of performance problems exists. Chimney height may need to be increased by 2% per each 1000 feet above sea level. It is not recommended to use offsets or elbows at altitudes above 4000 feet above sea level or when there are other factors that affect flue draft.

## INSTALLING CHIMNEY COMPONENTS

### Chimney Connector

Single wall connector or stove pipe.

This must be at least 24 gauge mild steel. The sections must be attached to the appliance and to each other with the crimped (male) end pointing toward the stove. All joints, including the connection at the flue collar, should be secured with sheet metal screws. Make sure to follow the minimum clearances to combustibles. Where passage through the wall, or partition of combustible construction is desired in Canada, the installation shall conform to CAN/CSA-B365.

### Chimney Termination Requirements

Follow manufacturer's instructions for clearance, securing flashing and terminating the chimney.

- Must have an approved and listed cap
- Must not be located where it will become plugged by snow or other material
- Must terminate at least feet (91cm) above the roof and at least 2 feet (61cm) above any portion of the roof within 10 feet (05cm).
- Must be located away from trees or other structures

### 2-10-3 Rule

**These are safety requirements and are not meant to assure proper flue draft.**

## OPERATION

Do not use a grate or elevate fire. Build wood fire directly on hearth. When the stove is used for the first time the solvents in the paint will smoke off.

### WOOD

This heater is designed to burn natural wood only. Higher efficiency and lower emissions generally result when burning air dried seasoned hardwood, as compared to softwood or to green or freshly cut hardwood. Only use

dry seasoned wood. Green wood, besides burning at only 60 percent of the fuel value of dry wood, deposits creosote on the inside of your stove and along the chimney. This can cause an extreme danger of chimney fire. To be called seasoned, wood must be dried for a year. Regardless of whether the wood is green or seasoned, it should be stored in a well-sheltered, ventilated area to allow proper drying during the year to come. Wood should be stored beyond recommended clearance from combustibles.

### DO NOT BURN:

- Treated Wood • Solvents • Trash • Coal
- Garbage • Cardboard • Coloured Papers

### INSTRUCTIONS FOR FIRST BURN - CURING THE STOVE PAINT

Your stove has been painted with the highest quality stove paint and has special break-in procedures. The heat generated by the normal operation of the stove, will serve to harden the paint. Ventilate the house during the first three times the stove is used. The paint on the stove will give off smoke, carbon dioxide and an odor. Without adequate ventilation, concentrations of smoke could irritate you or cause damage to person and/or property. Open doors and windows and use a fan if necessary. After the initial burns, the paint will be cured and there should be no more smoke.

Each of the initial burns should be conducted as follows:

1. The first and second burns should be at approximately 250 deg F (120 deg C) for approximately 20 minutes.
2. The third burn should be between 500 deg F (260 to 370 deg C) for at least 45 minutes. The important fact is the paint should be cured slowly. Avoid hot fires during the curing process. During the curing process the paint will be gummy. Once cured the paint will remain hard. It is normal to see flat spots on painted surfaces of the stove. The flat spots on the paint surface indicate the hotter surfaces of the stove, and is caused by the heat radiating through the paint. It is also expected that shiny spots caused by friction from the packaging materials, will disappear during the curing of the stove.

### SO:

1. Remember to Ventilate well.
2. Allow the stove to cure before burning for long periods at high temperatures.
3. Flat spots on the painted surfaces are normal.
4. Shiny spots on the paint surface before burning is normal.
5. Call your dealer if you have any questions.



## BUILDING A FIRE

Building a fire is a two-step process including a “Start-Up” fire that builds a bed of coals that provides an ignition source for the first sustained fire.

### Start-Up Fire Instructions

1. Open the Primary Air Slide to the maximum position.
2. Open the Slide Baffle Rod.
3. Open the Stove Door.
4. Build the “Start-Up” fire fuel configuration as instructed in Step 3 on page 11 of the manual.
5. Light the Newspaper and Small Kindling sticks with a match as instructed in Step 4 on page 11 of the manual.
6. Leave the door open 12 inches until the kindling pieces are burning vigorously.
7. Close the Door.
8. Close the Slide Baffle Rod.
9. Allow the fire to burn until there is a full bed of glowing embers.

### First Fire Instructions

1. Open the Slide Baffle Rod.
2. Open the Door.
3. Rake the Ember bed so it makes a level surface on the bottom of the stove.
4. Build the Start-Up fuel configuration as described in Step 7 on page 12 of the manual.
5. Leave the door open for one minute and then close the door.
6. Close the Slide Baffle Rod.
7. Adjust the Primary Air Slide to the desired setting.

**NEVER USE GASOLINE, GASOLINE-TYPE LANTERN FUEL, KEROSENE, CHARCOAL LIGHTER FLUID, OR SIMILAR LIQUIDS TO START OR FRESHEN UP A FIRE IN THIS HEATER. KEEP ALL SUCH LIQUIDS WELL AWAY FROM THE HEATER WHILE IT IS IN USE.**

## GLASS CARE

The following use and safety tips should be observed:

1. Inspect the glass regularly for cracks and breaks. If you detect a crack or break, extinguish the fire immediately, and contact your dealer for replacement.
2. Do not slam door or otherwise impact the glass. When closing doors, make sure that logs or other objects do not protrude and impact the glass.
3. Do not clean the glass with materials which may scratch (or otherwise damage) the glass. Scratches on the glass can develop into cracks or breaks.

4. Never attempt to clean the glass while unit is hot. If the deposit is not very heavy, normal glass cleaners are adequate with a plain, non-abrasive scouring pad. Heavier deposits may be removed with the use of a readily available oven cleaner.
5. Never put substances which can ignite explosively in the unit since even small explosions in confined areas can blow out the glass.
6. This unit has an airwash system, designed to reduce deposits on glass.
7. Deposits may build on the glass during normal operation and use. Normal glass cleaners work well to remove these deposits. Heavier deposits may be removed by using a damp cloth dipped in wood ashes or by using a commercially available oven cleaner.

REPLACE GLASS ONLY WITH GHP GROUP 5MM CERAMIC GLASS (SEE REPLACEMENT PARTS PAGE 18).

## GLASS REPLACEMENT

**CAUTION:** Make sure fire is out and stove is completely cool to the touch.

1. Find an area that will ensure safe removal and no damage to surface of door frame or decorative home furnishing.
2. Wearing a pair of protective gloves, remove the push nuts that retain the door pins from being pulled out and then lift the door off of the hinges.
3. Lay the door face down on a protective surface located in Step 2.
4. Remove the screws from all glass retainers and remove the broken glass, ensuring that the door frame is free from any splinters. (If even small splinters are left, the new glass will not seal correctly causing the stove to burn improperly.)
5. Attach glass gasket (from GHP Group replacement parts page 18) to new glass and install in door frame.
6. Replace glass retainers with screws making sure not to cross thread or overtighten.
7. Place door on hinges and replace new push nuts, purchased from GHP Group, on door pins to ensure door does not move after reinstall.

## GASKET REPLACEMENT

After extensive use, the sealing material which provides glass and door seal may need to be replaced if it fails to sustain its resilience. Inspect glass and door seal periodically to ensure for proper seal. If gaskets become frayed or worn, replace immediately.

Contact your dealer or GHP Group Customer Service for approved replacement parts. The following steps should be followed for glass gasket replacement:

1. Ensure appliance is not in operation and is thoroughly cooled.



2. Remove screw and glass clip.
3. Lift glass out from glass clip.
4. Remove old gasket and clean glass.
5. Replace new gasket starting at the bottom of glass working along edges, being sure to centre gasket channel on glass.
6. Trim to length and butt ends together.
7. Replace glass in door, being sure not to over-tighten screw and clip.

The following steps should be followed for door gasket replacement:

1. Ensure appliance is not in operation and is thoroughly cooled.
2. Remove old door gasket and clean channel.
3. Using an approved high temperature gasket cement, apply a thin coat in bottom of channel.
4. Starting at hinge side of door, work into channel around door unit, end butt and trim to length.
5. Close door and allow three to four hours for cement to set before restarting appliance.

## CREOSOTE

### Creosote - Formation and Need for Removal

When wood is burned slowly, it produces tar and other organic vapors, which combine with expelled moisture to form creosote. The creosote vapors condense in the relatively cool chimney flue of a slow-burning fire. As a result, creosote residue accumulates on the flue lining. When ignited this creosote makes an extremely hot fire.

The chimney connector and chimney should be inspected at least once every two months during the heating season to determine if a creosote buildup has occurred.

If creosote has accumulated (3 mm or more) it should be removed to reduce the risk of a chimney fire.

### WAYS TO PREVENT AND KEEP UNIT FREE OF CREOSOTE

1. Burn with air control open for several minutes at numerous intervals throughout the day during the heating season, being careful not to over-fire unit. This removes the slight film of creosote accumulated during low burn periods.
2. Burn stove with draft control wide open and slide baffle rod handle in the "OPEN" position for several minutes every time you apply fresh wood. This allows wood to achieve the charcoal stage faster and burns wood vapours which might otherwise be deposited within the system.
3. BURN ONLY SEASONED WOOD. Avoid burning wet or green wood. Seasoned wood has been dried for at least one year.
4. A small hot fire is preferable to a large smouldering

- one that can deposit creosote within the system.
5. Establish a routine for the fuel, wood burner and firing technique. Check daily for creosote build-up until experience shows how often you need to clean to be safe. Be aware that the hotter the fire, the less creosote is deposited and weekly cleanings may be necessary in mild weather even though monthly cleanings may be enough in the coldest months. Contact your local municipal authority for information on how to handle a chimney fire. Have a clearly understood plan to handle a chimney fire.

**WARNING: Things to remember in case of chimney fire:**

1. CLOSE DRAFT CONTROL.
2. CALL THE FIRE DEPARTMENT.

## ASH DISPOSAL

This unit features a convenient ash lip for easy removal of ash. During constant use, ashes should be removed every few days, or whenever ashes get to three to four inches deep in the firebox. Remove ashes only when the fire has died down and the ashes have cooled. Even then, expect to find a few hot embers.

### Disposal of Ashes:

Ashes should be placed in a steel container with a tight-fitting lid. The container of ashes should be moved outdoors immediately and placed on a noncombustible floor or on the ground, well away from combustible materials, pending final disposal. If the ashes are disposed of by burial in soil or otherwise locally dispersed, they should be retained in the closed container until all cinders have thoroughly cooled. Other waste shall not be placed in this container.

## USING THE ASH DRAWER

**NOTE: Coals may still be hot even though stove feels cool to the touch.**

1. Make sure stove is completely cool.
2. Open glass door and lift up the firebrick for ash drawer using a fireplace poker through the metal hook raised from the top of the brick and set aside in firebox.
3. Using a small hand broom, sweep the ashes into the opening, allowing the ashes to fall into the ash pan.
4. Make sure all debris is clear of the opening. This is important to ensure the firebrick (when replaced) seals to the metal stove bottom. If the fire brick is not properly sealed, the stove will not operate correctly.
5. Using gloves, pull out the ash drawer while holding the bottom of the ash pan so it doesn't fall out onto the floor.

6. Dispose of the ashes in a metal container with a tight-fitting lid.
7. Replace ash pan drawer and firebrick to their original positions.

## IMPORTANT

### HELPFUL HINTS

#### 1. What is the correct way to start a fire?

- a) You will need small pieces of dry wood (kindling) and paper. Use only newspaper or paper that has not been coated or had unknown materials glued or applied to it. Never use coated (typically advertising flyers) or coloured paper.
- b) Rotate the slide baffle rod handle to the "OPEN" position and open the door of the wood stove.
- c) Crumple several pieces of paper and place them in the center of the firebox and directly on to the fire bricks of the wood stove. Never use a grate to elevate the fire.
- d) Place small pieces of dry wood (kindling) over the paper in a Teepee manner. This allows for good air circulation, which is critical for good combustion.
- e) Light the crumpled paper in 2 or 3 locations.  
Note: It is important to heat the air in the stovepipe for draft to start.
- f) Fully open the air control of the wood stove and close the door until it is slightly open, allowing for much needed air to be introduced into the fire box. Never leave the door fully open as sparks from the kindling may occur causing injury or property damage. As the fire begins to burn the kindling, some additional kindling may be needed to sustain the fire. DO NOT add more paper after the fire has started.
- g) Once the kindling has started to burn, start by adding some of your smaller pieces of seasoned (dry) firewood. NOTE: Adding large pieces at the early stages will only serve to smother the fire. Continue adding small pieces of seasoned (dry) firewood, keeping the door slightly open until each piece starts to ignite. Remember to always open the door slowly between placing wood into the fire.
- h) Once the wood has started to ignite and the smoke has reduced, close the wood stove door fully. The reduction of smoke, is a good indication that the draft in the chimney has started and good combustion is

now possible. Larger pieces of seasoned (dry) fire wood can now be added when there is sufficient space in the Firebox. Adjust the air control setting to desired setting. Remember to always open the Slide Baffle Rod Handle before opening the Stove door to prevent smoke spillage! Close the Slide Baffle Rod Handle only after the Stove Door is closed.

I) Note: The lower the air control setting the longer the burn time of your firewood.

#### 2. What type of wood is best to use as Firewood?

Dry seasoned hardwood should be used. Avoid green unseasoned wood. Green wood, besides burning at only 60 percent of the fuel value of dry seasoned wood, will deposit creosote on the inside of your stove and along the inside of your chimney.

#### 3. What does dry seasoned wood mean, and what is considered hardwood?

Wood that has been dried for a period of one year in a well-ventilated and sheltered area would be considered dry seasoned wood. Hardwoods are generally from slow growth trees (Example: Oak and Fir). Softwoods are generally from fast growth trees. (Example: Pine and Spruce)

#### 4. Will following the above listed steps for starting a fire result in perfect results all the time?

The quick answer is most of the time. There are many variables that may affect your success rate when starting a fire. Most of those variables and how to deal with them will be learned through experience. Your ability to start a good fire will significantly increase with time and patience. Some of the reasons for poor stove performance will be covered in the next section of these instructions.

#### 5. Why can't I get the fire lit?

Damp or wet wood and poor draft are the main reasons for poor results in starting a fire. Always use dry seasoned wood for your fire. Even wood dried for

two years will be difficult to ignite, if it has become wet.

#### 6. Why is there always a large quantity of thick black smoke present in the firebox?

A large quantity of thick black smoke in the firebox, is a good indication that the draft is poor.

#### 7. Is it normal for soot to cover the glass at the beginning of a fire?

Your stove has been built with an air wash system

that will help keep the glass clear when the firebox has reached a good operating temperature, and has a good draft. Cold firebox temperature and poor draft cause sooting of the glass. Once the firebox temperature and the draft increases, the soot will burn off.

### **8. What is draft?**

Draft is the ability of the chimney to exhaust draw by-products produced during the normal combustion process.

### **9. What can cause a poor draft?**

The most common factors for poor draft are:

- a) Atmospheric pressure and air supply
- b) Environmental conditions
- c) Cold chimney temperature
- d) Poor chimney installation and maintenance

#### **Atmospheric Pressure and Air Supply**

Atmospheric pressure affecting the draft from a chimney can be either outside the home, inside the home or both. Outside the home, a high-pressure day (clear and cool) generally creates a better draft in the chimney than a low-pressure day (overcast and damp). Inside the home, normal household appliances, such as clothes dryers and forced air furnaces compete for air resulting in inadequate amounts of air available to fuel a fire and create a condition known as negative pressure. Under extreme conditions of negative pressure

the combustion by-products can be drawn from the chimney and into the house. This condition is commonly referred to as down drafting. There are several factors that impact the amount of air available in the home. Increased amounts of insulation vinyl windows, extra caulking in various places and door seals can all keep heat in but may also make a home too airtight. If you are in doubt about whether or not there is sufficient air in your home for your stove, refrain from using

those appliances known to consume the air where possible, or open a window or door to allow air to enter the home.

#### **Environmental Conditions**

High trees, low lying house location such as in a valley, tall buildings or structures surrounding your

house and windy conditions can cause poor draft or down drafting.

#### **Cold Chimney Temperature**

Avoid cold chimney temperatures by burning a hot fire for the first fifteen to forty minutes, being careful not to over fire. If any part of the chimney or parts of the stove start to glow, you are over firing the stove. Where possible, install a temperature gauge on the chimney so temperature drops can be seen.

#### **Chimney Installation and Maintenance**

Avoid using too many elbows or long horizontal runs. If in doubt, contact a chimney expert and/or chimney manufacturer for help. Clean chimney, rain caps and especially spark arrester regularly, to prevent creosote build-up, which will significantly reduce chimney draw and may cause a chimney fire.

### **10. Should I close or open the air control fully when shutting down the stove?**

When shutting down the stove, fully open the air control. This allows the chimney temperatures to remain as high as possible for as long as possible. Cold chimney temperatures create creosote.

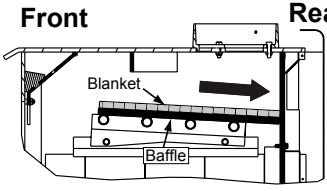
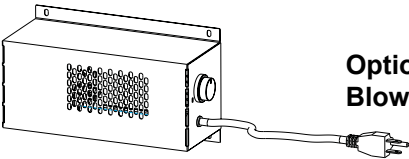
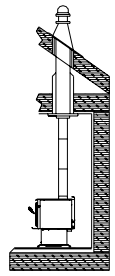
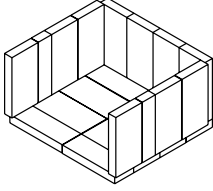
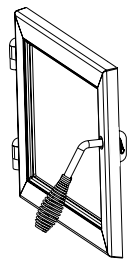
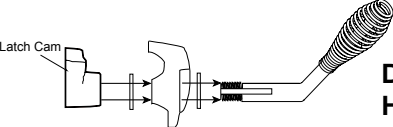
**NOTE:** This sheet is intended as an aid and does not supersede any local, provincial or state requirements. Check with officials or authorities having jurisdiction in your area.

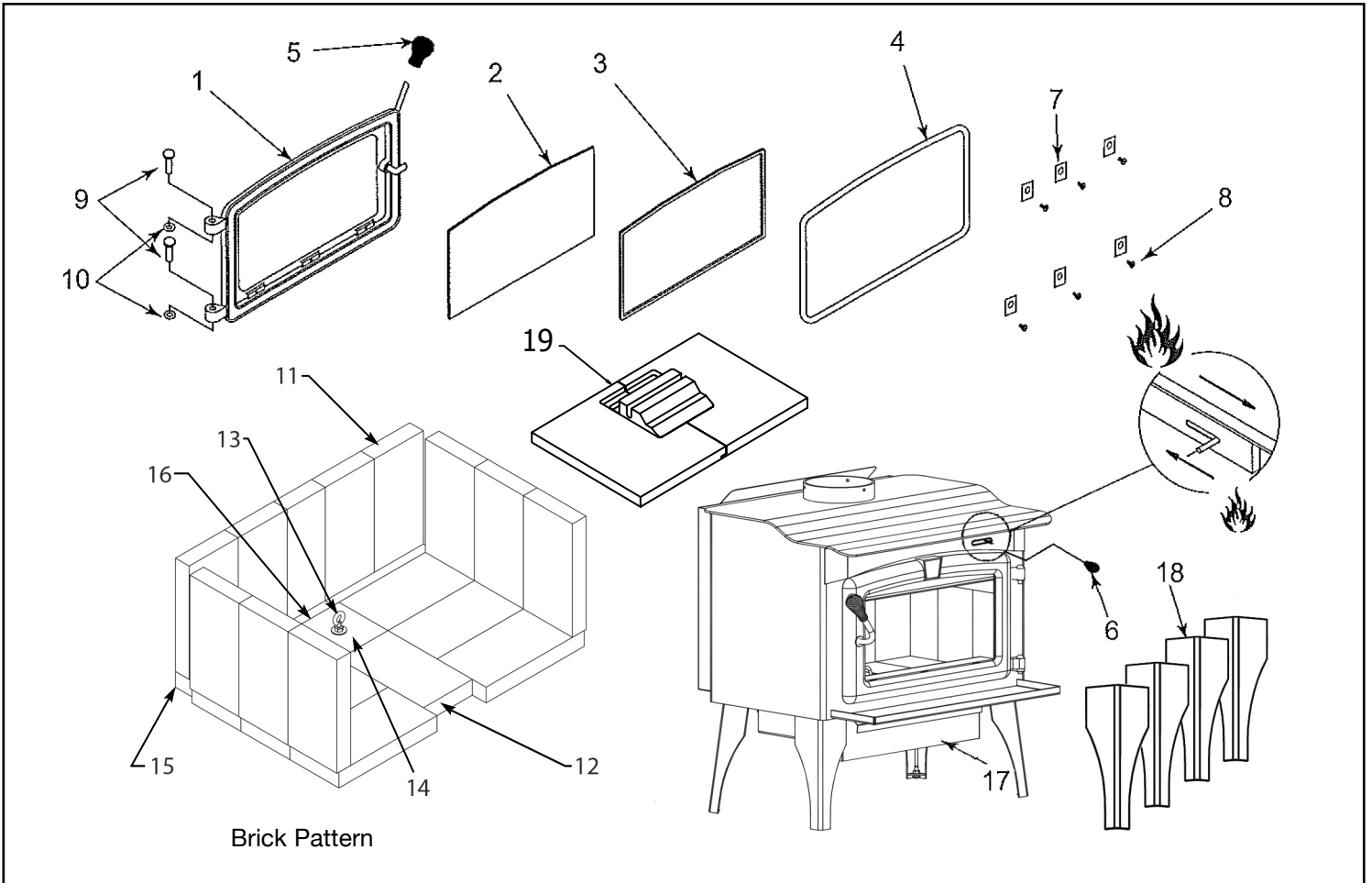
## QUICK REFERENCE MAINTENANCE GUIDE



**CAUTION!** Allow the appliance to completely cool down before performing any cleaning or maintenance.

Start the first inspection after the first 2 months of use, or if performance changes, and adjust your schedule accordingly. Maintenance is required for safe operation and must be performed to maintain your warranty.

AREA OF MAINTENANCE	FREQUENCY	TASK
 <p><b>Baffle &amp; Blanket</b></p>	<p>MONTHLY or After Every Cord of Wood</p>	<p>Baffle and blanket placement is critical to heat output, efficiency and overall life of the unit. Make sure the baffle is pushed all of the way to the back of the firebox and the blanket is laying flat. Inspect baffle for cracks.</p>
 <p><b>Optional Blower</b></p>	<p>YEARLY or After Every 4 Cords of Wood</p>	<p>Vacuum the blower impellers.</p>
 <p><b>Chimney System</b></p>	<p>EVERY 2 MONTHS or After Every 4 Cords of Wood</p>	<p>The chimney and chimney cap must be inspected for soot and creosote every two months during the burn season or more frequency if chimney exceeds or is under 14-16 ft (4.3m- 4.8m) measured from bottom of appliance. This will prevent pipe blockage, poor draft, and chimney fires. Always burn dry wood to help prevent cap blockage and creosote build-up.</p>
 <p><b>Firebrick &amp; Ash Removal</b></p>	<p>WEEKLY or After Every 25 Loads of Wood</p>	<p>Ashes must be cool before you can dispose of the ashes in a non-combustible container.  Firebrick is designed to protect your firebox. After ashes are removed, inspect the firebrick and replace firebricks that are crumbling, cracked or broken.</p>
 <p><b>Door &amp; Glass Assemblies</b></p>	<p>WEEKLY or After Every 25 Loads of Wood</p>	<p>Keep door and glass gasket in good shape to maintain good burn times on a low burn setting. To test: place a dollar bill between the stove and door and then shut the door. If you can pull the dollar out, replace the door gasket.  Check the glass frame for loose screws to prevent air leakage. Check glass for cracks.</p>
 <p><b>Door Handle</b></p>	<p>WEEKLY or After Every 25 Loads of Wood</p>	<p>Check the door latch for proper adjustment. This is very important especially after the door rope has formed to the stove face. Check door handle for smooth cam operation.</p>



GHP Group reserves the right to make changes in design, materials, specifications, prices and discontinue colors and products at any time, without notice.

Item No.	Description	Qty.	Part No.
1	Door Assembly	1	75-21-182
2 & 3	Glass (17.00" W x 9.75") and Gasket	1	75-21-514
3	1/8" Glass Gasket	4.3'	75-21-123
4	5/8" Door Gasket	5.1	75-21-143
5	Spring Handle	1	75-20-140
6	Air Control Sprint Handle	1	75-20-141
7	Glass Clip	6	75-25-131
8	Screw	6	75-21-141
9	Hinge Pin	2	75-20-132
10	Push Nut	2	75-21-150

Item No.	Description	Qty.	Part No.
11	Firebrick Lt. 9" x 4 7/16" x 1 1/4"	16	75-21-147
12	Firebrick Lt. 7 3/4" x 4 7/16" x 1 1/4"	1	75-26-106
13	Firebrick Lt. 9" x 3 1/2" x 1 1/4"	1	75-26-126
14	Firebrick for Ash Drawer	1	75-21-149
15	Firebrick Lt. 9" x 2" x 1 1/4"	2	75-26-108
16	Firebrick Lt. 3 1/4" x 4 7/16" x 1 1/4"	1	75-26-107
17	Ash Drawer Assembly	1	75-22-507
18	Leg Assembly	4	75-22-510
19	Insulation Baffle Assembly	1	EXP-A9999-MDBY





# 5 Year Warranty

GHP Group warrants that your new wood-burning stove, pellet-burning stove, or masonry wood insert is free from manufacturing and material defects for a period of five years from the date of sale, subject to the following conditions and limitations.

1. This warranty is extended to the original owner only, for residential use, and is subject to proof of purchase.
2. The new GHP Group product must be installed and operated at all times in accordance with the installation and operation instructions supplied with the appliance, and installation must be to local and national codes. Any alterations, willful abuse, accident, over firing or misuse will not be covered under warranty. NOTE: Some minor movement of certain parts is normal and is not a defect and therefore, not covered under warranty.
3. The warranty is non-transferable, and is made to the original owner, provided that the purchase was made through an authorized GHP Group supplier. The serial number must be supplied along with the Bill of Sale, showing the date of purchase, at the time the claim is submitted.
4. This warranty is limited to the repair or replacement of parts only, found to be defective in material or construction, provided that such parts have been subjected to normal conditions of use and service, after a said defect has been confirmed by GHP Group, or an authorized representative's inspection. Defective parts must be shipped back (at GHP Group discretion), transportation prepaid, to the manufacturer. Credits will be issued upon receipt of return of the defective product to GHP Group.
5. GHP Group, at its discretion, can fully discharge all obligation with respect to this warranty by refunding the wholesale price of the defective part(s).
6. Any installation, labor, construction, transportation or other related costs or expenses arising from defective parts, repair, replacement or otherwise of same, will not be covered by this warranty nor will GHP Group assume responsibility for same. Further, GHP Group will not be responsible for any incidental, indirect or consequent damages, except as provided by law, and in no event shall they exceed the original purchase price.
7. All other warranties - expressed or implied - with respect to the product, its components and accessories, or any obligations/liabilities on the part of GHP Group are hereby expressly excluded.
8. GHP Group neither assumes, nor authorizes any third party to assume, on GHP Group's behalf, any other liabilities with respect to the sale of this GHP Group product.
9. The warranties as outlined within this document do not apply to chimney components or other products made by other manufacturers when used in conjunction with the installation of this product. Improper use or the use of non-approved components may nullify your warranty. If in doubt, contact your nearest GHP Group supplier or GHP Group Customer Service Department.
10. GHP Group will not be responsible for:
  - Downdrafts or spillage caused by environmental conditions such as nearby trees, buildings, rooftops, hills, mountains, or ineffective

chimney design.

- Inadequate ventilation, excessive offsets or negative air pressure caused by mechanical systems such as furnaces, clothes dryers, fans, etc.

11. This warranty is void if:

- The appliance has been operated in atmospheres contaminated by chlorine, fluorine, or other damaging chemicals.
- This appliance has been subjected to prolonged periods of dampness or condensation.
- The appliance has any damage due to water, or weather damage that is the result of, but not limited to, improper chimney/venting installation.
- The appliance has been subjected to willful or accidental abuse or misuse.
- Corrosive driftwood, manufactured logs or other fuels are used other than as outlined in the installation and operating instructions.
- The appliance is not maintained in good condition, including firebrick and gaskets.

## Doors with Glass and Plated Parts

Glass is warranted against thermal breakage only. To clean glass, use a ceramic/glass cleaner or polish. Do not use ammonia based cleaners. A suitable cleaner is available at your nearest Pleasant Hearth dealer.

## DO NOT CLEAN GLASS WHILE HOT AND DO NOT USE ABRASIVE CLEANERS.

Plated parts will not be covered under this warranty. Plated parts should be cleaned by using denatured alcohol only and rubbed lightly with a lint-free non-abrasive cloth. Excessive rubbing or polishing may remove the plated finish. Plated parts may also be damaged by external chemicals.

## Further Exclusions

### WOOD-BURNING STOVE

Electrical components, such as the blower, are covered for five (5) years from the date of purchase if they are included with the purchase of your stove.

This warranty will not include or extend to paint, gaskets or firebrick components, and does not cover any removable firebox components such as brick retainers or stainless steel air tubes.

### PELLET-BURNING STOVE:

Five Year Period:

1. Carbon steel and welded seams in the firebox are covered for five (5) years against splitting.

2. The steel door and hinges are covered for five (5) years against cracking.

One Year Period:

1. Component parts such as the hopper, auger, burn-pot, baffle plate, auger shaft and fasteners are covered for one (1) year against cracking, breakage and welded seam separation.

2. Electrical components, accessory items, glass and the painted surface of the stove are covered for one (1) year from the date of purchase.

TO REGISTER THE WARRANTY ON YOUR HEATER, PLEASE FILL OUT THIS CARD COMPLETELY AND MAIL WITHIN 14 DAYS FROM DATE OF PURCHASE OR REGISTER ON-LINE AT [www.ghpgroupinc.com](http://www.ghpgroupinc.com)

NAME: \_\_\_\_\_ PHONE: ( ) \_\_\_\_\_ EMAIL: \_\_\_\_\_  
 ADDRESS: \_\_\_\_\_ CITY: \_\_\_\_\_ STATE: \_\_\_\_\_ ZIP: \_\_\_\_\_  
 MODEL: \_\_\_\_\_ SERIAL #: \_\_\_\_\_ DATE PURCHASED: \_\_\_\_\_  
 DEALER PURCHASED FROM: \_\_\_\_\_ TYPE OF STORE: \_\_\_\_\_  
 CITY & STATE WHERE PURCHASED: \_\_\_\_\_ PRICE PAID: \_\_\_\_\_

### Please Take a Minute To Give Us Your Answers To The Following Questions.

#### All Responses Are Used Solely For Market Research And Are Held In Strict Confidence.

Who primarily decided this purchase?  Male  Female  18-24  25-39  40-59  60 and over

Purpose of Purchase? \_\_\_\_\_

Do you own any other portable heaters?  Yes  No If yes, type \_\_\_\_\_ brand \_\_\_\_\_

How do you intend to use your new heater?  Construction Site  Farm  Warehouse/Commercial  Garage/Outbuilding  Other

How did you become aware of this heater?  In-Store Display  Newspaper Ad  Magazine Ad  Friend/Relative

TV Commercial  Store Salesperson  Other \_\_\_\_\_

What made you select this heater?  Style  Size/Portability  Price  Package  Brand  Other \_\_\_\_\_

Do you:  own  rent Would you recommend this heater to a friend?  Yes  No

Please give us your comments: \_\_\_\_\_

THANK YOU FOR COMPLETING THIS FORM!

Information will be held confidential.



**IF WARRANTY SERVICE IS REQUIRED**

Contact GHP Group Customer Service. Make sure you have your sales receipt and the model/serial number of your GHP Group product.

Do not attempt to do any service work yourself, unless pre-approved by GHP Group in writing as this will void the warranty.

GHP Group must authorize service and provide a Warranty Claim Number prior to any warranty related service calls. Without an authorization number, any service work will not be deemed warranty.

**WARRANTY REGISTRATION**

**IMPORTANT:** We urge you to fill out your warranty registration card within fourteen (14) days of date of purchase. You can also register your warranty on the internet at [www.ghpgroupinc.com](http://www.ghpgroupinc.com). Complete the entire serial number. Retain this portion of the card for your records.



**GHP Group, Inc.**  
6440 W. Howard St.  
Niles, IL 60714-3302

Tel: (877) 447-4768  
[www.ghpgroupinc.com](http://www.ghpgroupinc.com)

**SAVE THIS CARD!**

Place  
Postage  
Stamp  
Here

**GHP Group, Inc.**  
**6440 W. Howard St.**  
**Niles, IL 60714-3302**

# **Appendix B**

## **Alt-125 E3053 Letter**



UNITED STATES ENVIRONMENTAL PROTECTION AGENCY  
RESEARCH TRIANGLE PARK, NC 27711

FEB 28 2018

Mr. Justin White

OFFICE OF  
AIR QUALITY PLANNING  
AND STANDARDS

Dear Mr. White,

I am writing in response to your letter dated January 12, 2018, regarding wood heaters manufactured by Hearthstone QHPP, Inc. (Hearthstone). This response, dated February 28, 2018, supercedes our previous response (dated February 26, 2018) to correct an inaccuracy regarding required changes to ASTM E3053-17.

You are requesting to use an alternative test method, using cord wood, as referenced in section 60.532(c) of 40 CFR part 60, Subpart AAA, Standards of Performance for New Residential Wood Heaters (Subpart AAA) to meet the 2020 cord wood alternative compliance option. The 2020 cord wood alternative compliance option states that each affected wood heater manufactured or sold at retail for use in the United States on or after May 15, 2020, must not discharge into the atmosphere any gases that contain particulate matter in excess of 2.5 g/hr. Compliance must be determined by a cord wood test method approved by the Administrator along with the procedures in 40 CFR 60.534. You have requested approval to use the procedures and specifications found in ASTM Method E3053-17, a cord wood test method titled, "Standard Test Method for Determining Particulate Matter Emissions from Wood Heaters using Cordwood Test Fuel," in conjunction with ASTM E2515-11 and Canadian Standards Administration (CSA) Method CSA-B415.1-10, which are specified in 40 CFR 60.534.

We understand that Hearthstone is also requesting that the alternative method proposed above be approved to apply broadly to all wood heaters manufactured by Hearthstone meeting the requirements of Subpart AAA, from the approval date of this request until such time that Subpart AAA is revised or replaced to require a different cord wood certification method, providing all requirements of section 60.533 of Subpart AAA are met.

With the caveats set forth below, we approve your alternative test method request for certifying wood heaters using ASTM E3053-17 in conjunction with section 60.534 of Subpart AAA to meet the 2020 cord wood compliance option until such time that Subpart AAA is revised or replaced to require a different cord wood certification method. We also approve application of this alternative method to all wood heaters manufactured by Hearthstone meeting the requirements of Subpart AAA.

As required in Subpart AAA, section 60.354(d), you or your approved test laboratory must also measure the first hour of particulate matter emissions for each test run using a separate filter in one of the two parallel sampling trains. These results must be reported separately and also included in the total particulate matter emissions per run. Also, as required by Subpart AAA, section 60.534(e), you must have your approved laboratory measure the efficiency, heat output, and carbon monoxide emissions of the tested wood heater using CSA-B415.1-10. For measurement of particulate matter emission concentrations, ASTM 2515-11 must be used.

The following change to ASTM E3053-17 must be followed:

1. Coal bed conditions prior to loading test fuel. The coal bed shall be a level plane without valleys or ridges for all test runs in the high, low, and medium burn rate categories.

The following changes to ASTM E2515-11 must be followed:

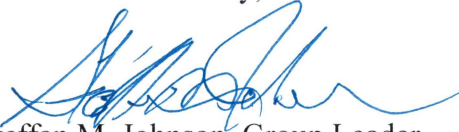
1. The filter temperature must be maintained between 80 and 90 degrees F during testing.
2. Filters must be weighed in pairs to reduce weighing error propagation; see ASTM 2515-11, Section 10.2.1 Analytical Procedure.
3. Sample filters must be Pall TX-40 or equivalent Teflon-coated glass fiber, and of 47 mm, 90 mm, 100 mm, or 110 mm in diameter.
4. Only one point is allowed outside the +/- 10 percent proportionality range per test run.

A copy of this letter must be included in each certification test report where this alternative test method is utilized.

It is reasonable that this alternative test method approval be broadly applicable to all wood heaters subject to the requirements of 40 CFR part 60, Subpart AAA. For this reason, we will post this letter as ALT-125 on our website at <http://www3.epa.gov/ttn/emc/approalt.html> for use by other interested parties. As noted earlier in this letter, this alternative method approval is valid until such time that Subpart AAA is revised or replaced to require a different cord wood certification method, and at such time, this alternative will be reconsidered and possibly withdrawn.

If you have additional questions regarding this approval, please contact Michael Toney of my staff at 919-541-5247 or [toney.mike@epa.gov](mailto:toney.mike@epa.gov).

Sincerely,



Steffan M. Johnson, Group Leader  
Measurement Technology Group

cc: Amanda Aldridge, EPA/OAQPS/OID  
Adam Baumgart-Getz, EPA/OAQPS/OID  
Rafael Sanchez, EPA/OECA  
Michael Toney, EPA/OAQPS/AQAD