

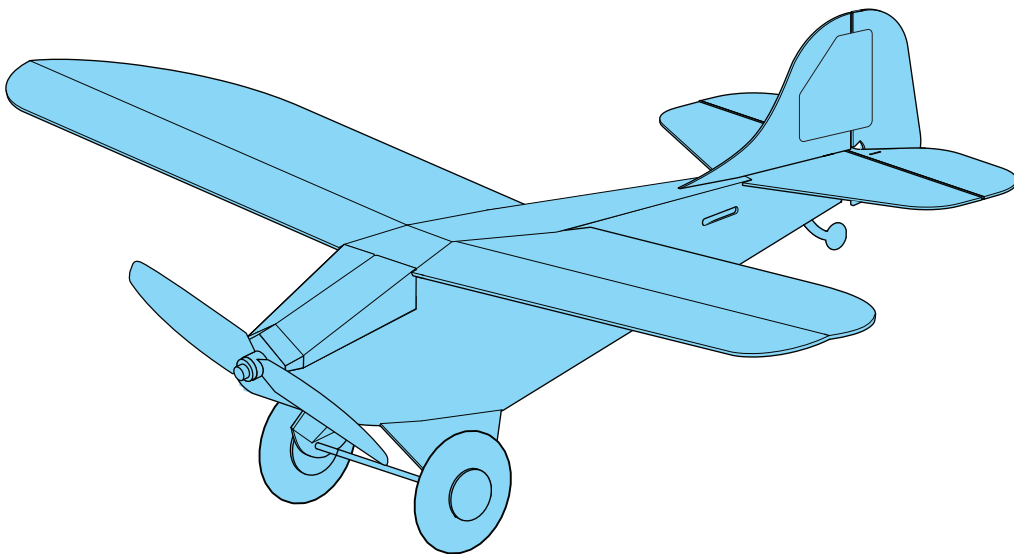

ASSEMBLY GUIDE



Scrappee Classic/Liaison

Version 2



Introduction

Thank you for purchasing this Microaces Aero Kit. Designed using innovative ideas, advanced materials and detailed aircraft illustrations, this aircraft will bring you hours of building enjoyment and many more exciting flying hours too. Please take your time to familiarise yourself with these instructions as the aircraft assembles in a very unique way, following a sequence of steps that should be adhered too to ensure a satisfactory and flyable model.

Safety

It is extremely important to us that you and those around you remain safe while building and flying Microaces kits. Please take note of the following notices of safety. Microaces Aero kits contain parts and packaging **unsuitable** for handling by small children. Please ensure that children under the age of 6 years are prevented from handling the component parts or packaging of this kit. Although the resulting model is lightweight, we DON'T recommend that you fly it near or over others where there is a danger of striking someone. We DO recommend that the maiden flight is performed over long grass in calm weather away from others.

Assembly

Read all the instructions carefully before starting assembly. It is important to use the recommended glues or an equivalent with similar properties. Foam parts must be glued with a foam safe cement or permanent damage can result to components. Ensure your knife has a fresh or sharp blade installed to ensure a clean cut.

Warranty

Microaces warrants this kit is supplied with all components present and that those components are free from cosmetic or structural damage to an extent that would impair the assembly of the kit, alter the aesthetics of the built model and/or the flight performance of the resulting model. If any parts are missing or damaged please contact us via email at: support@microaces.com

Key

- | | |
|--|--|
|  Note (Information) |  Attention |
|  Part Number |  Do Not Glue |
|  Contact Adhesive (Foam Safe) |  Score before assembly |
|  Sanding Required |  Cut |
|  Area of adhesion for glue |  Refer to Video tutorial for more info |

KIT PARTS

Sheet Parts	1 x 2mm Laser cut foam airframe 1 x 1mm printed & laser cut foam fuselage 2 x 1mm printed & laser cut foam flight surfaces 1 x 200 micron printed & laser cut polypropylene 1 x polyester sticker sheet 1 x 0.8mm laser cut plywood motor mount
Loose Parts	1 x piano wire elevator control rod 1 x piano wire rudder control rod 2 x 3D printed wheel hubs 2 x Sponge Tyres 4 x Ø 4mm x 1mm neodymium magnets 4 x Ø 3mm x 1mm neodymium magnets 1 x 160mm x 0.4mm x 1mm carbon fibre strip 1 x 105mm or 100mm carbon fibre Ø 1mm rod 1 x Self adhesive Hook & Loop strips

RECOMMENDED TOOLS/GLUES

Knife or Scalpel with fresh blade

Steel Rule or straight edge

Sanding Stick or sand paper (180 grit recommended)

Tweezers

Needle nose pliers

UHU por foam safe adhesive (For foam & plastic)

2mm FOAM

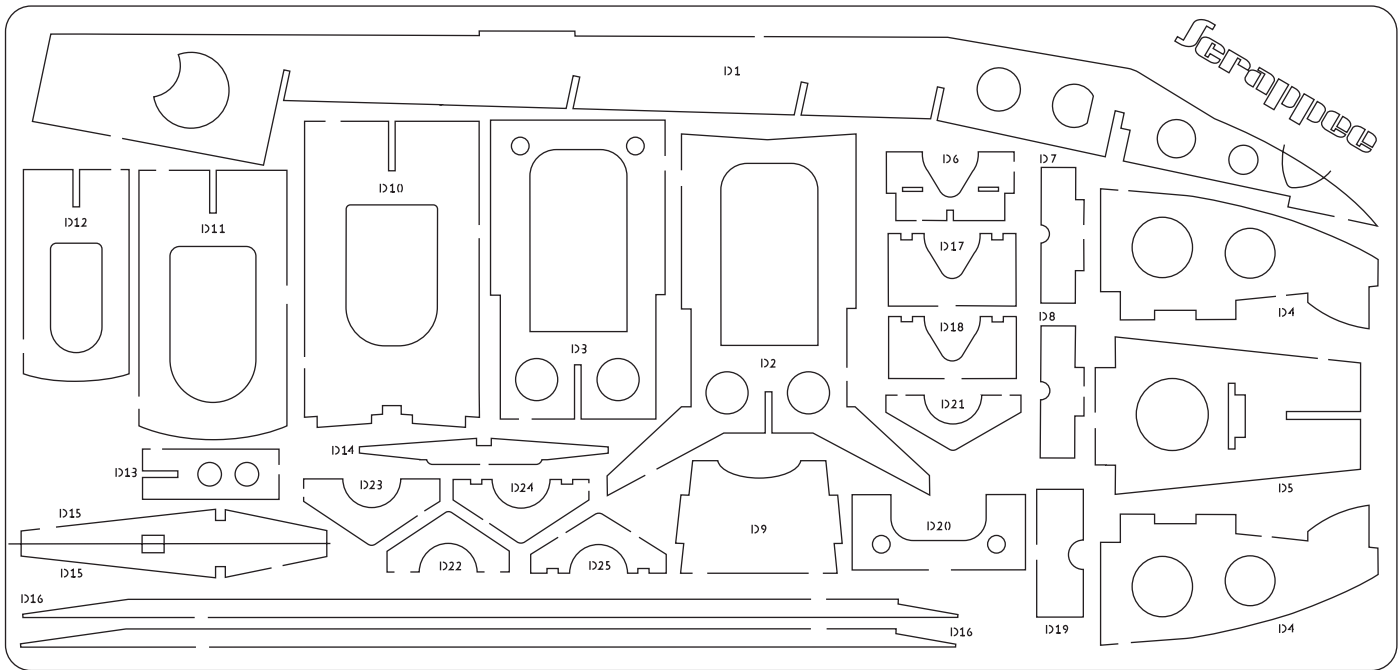

PLASTIC PARTS

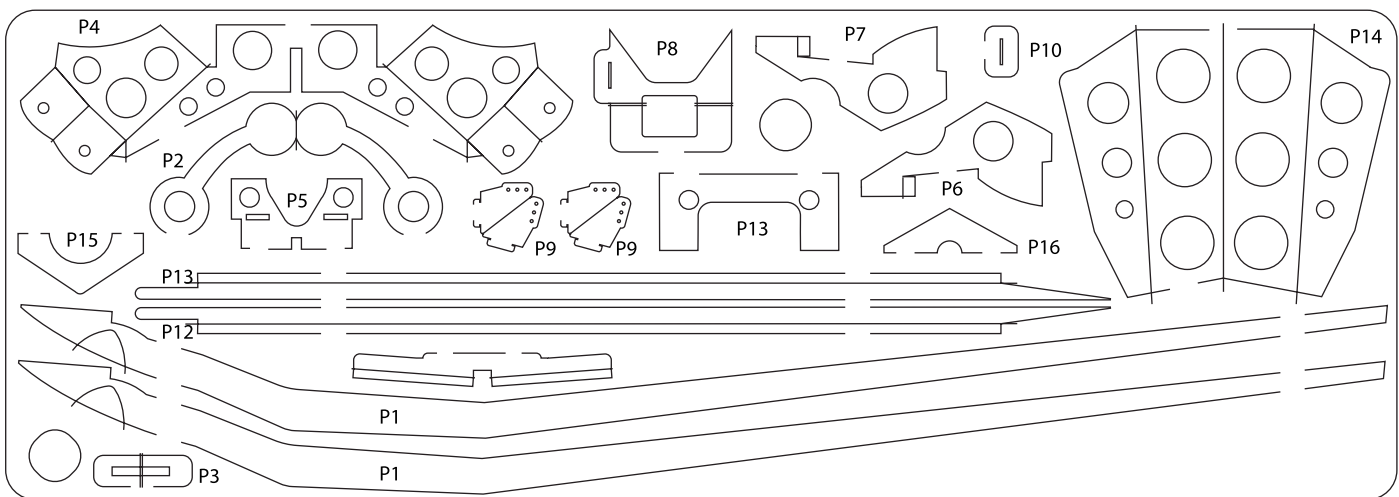

1mm FOAM

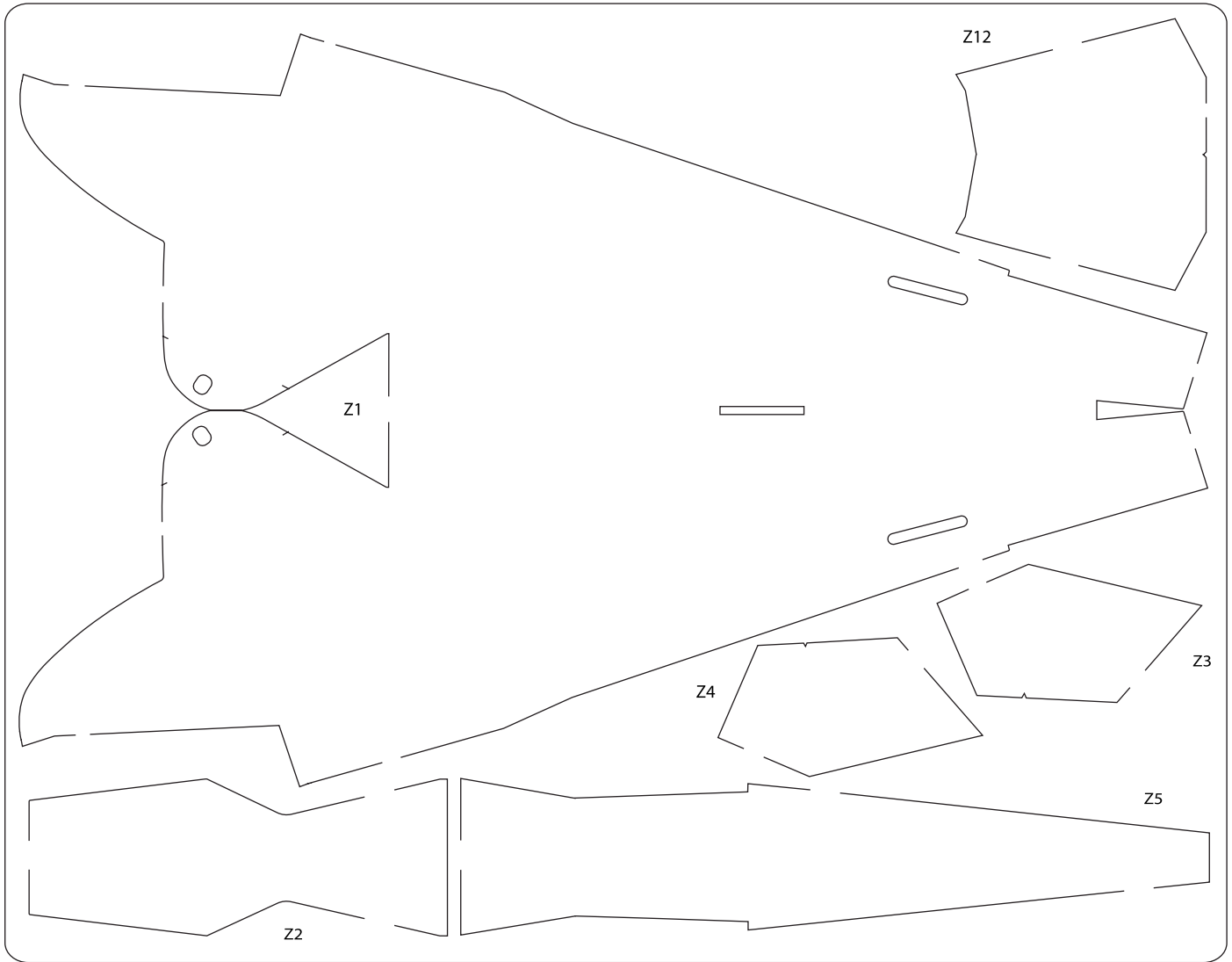

STICKERS

Patriot II

Classic

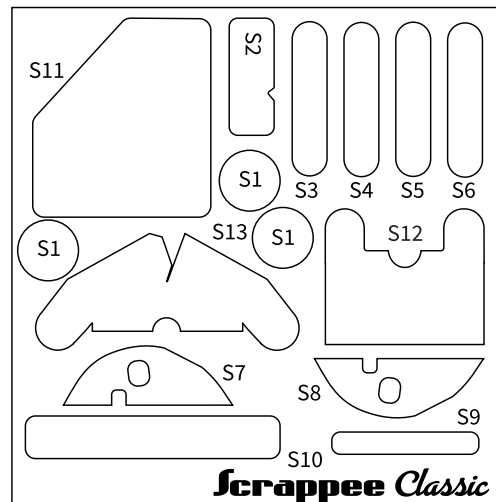
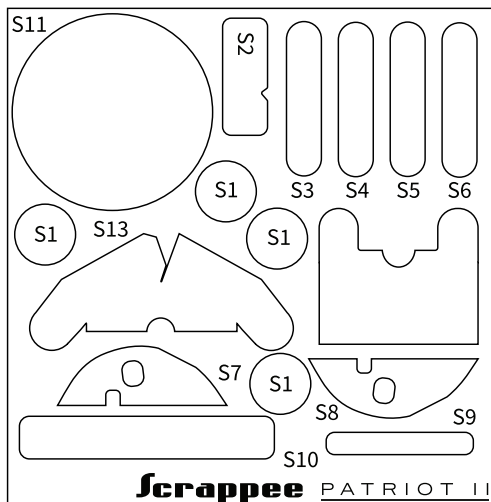

1mm FOAM

Classic

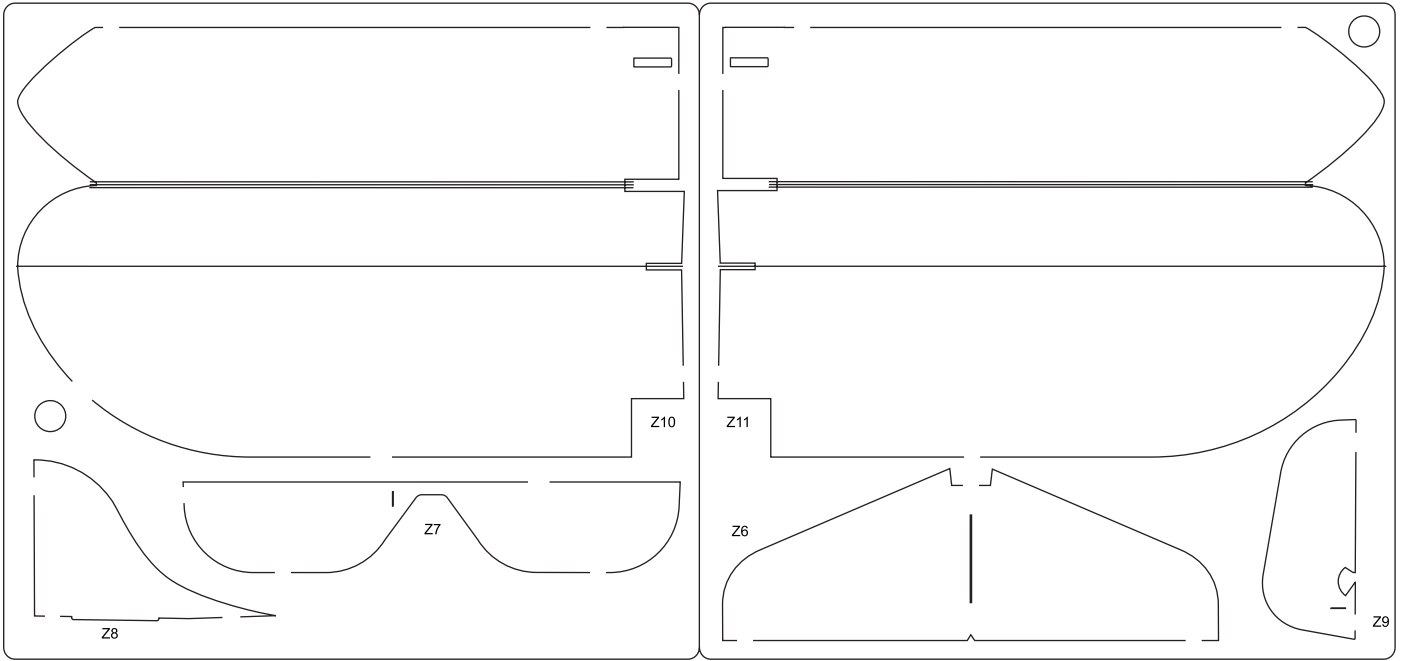

1mm FOAM

Patriot II

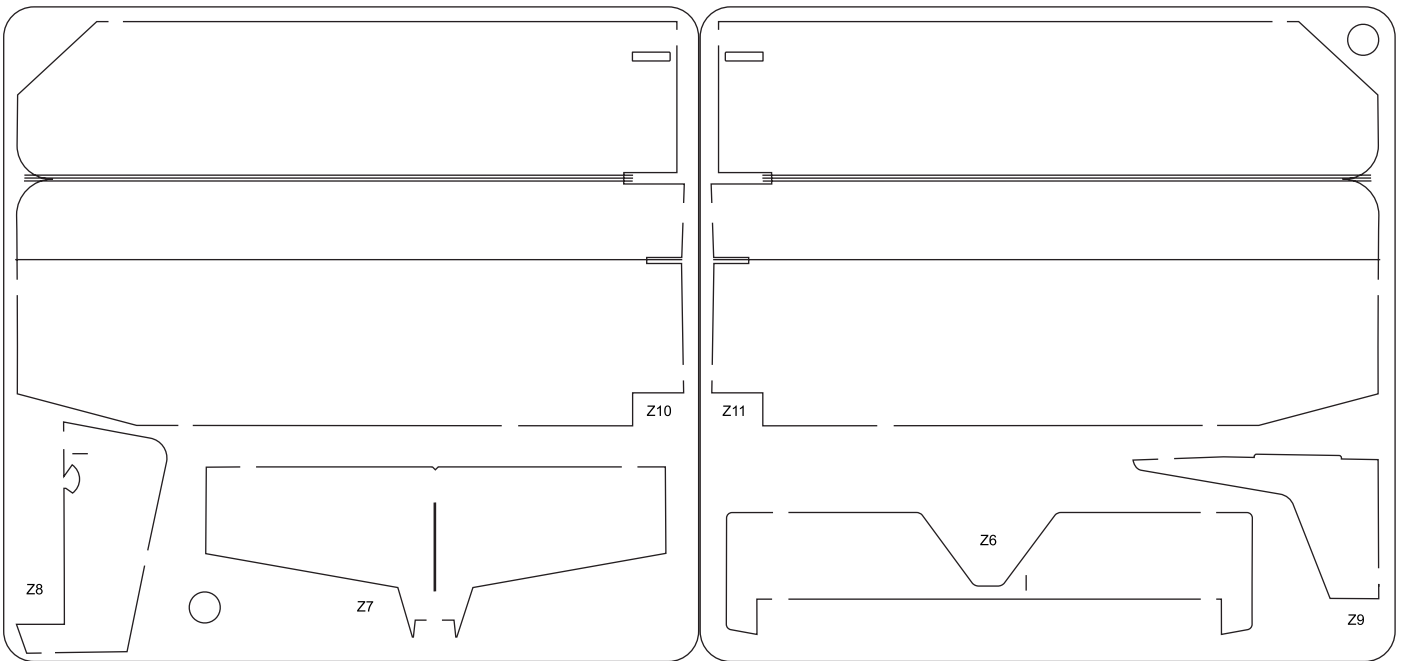

0.8mm PLYWOOD

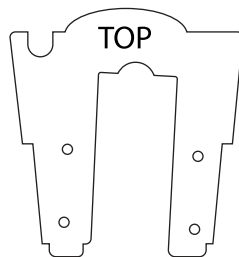



! Always score on the UNPRINTED side of the foam unless otherwise directed

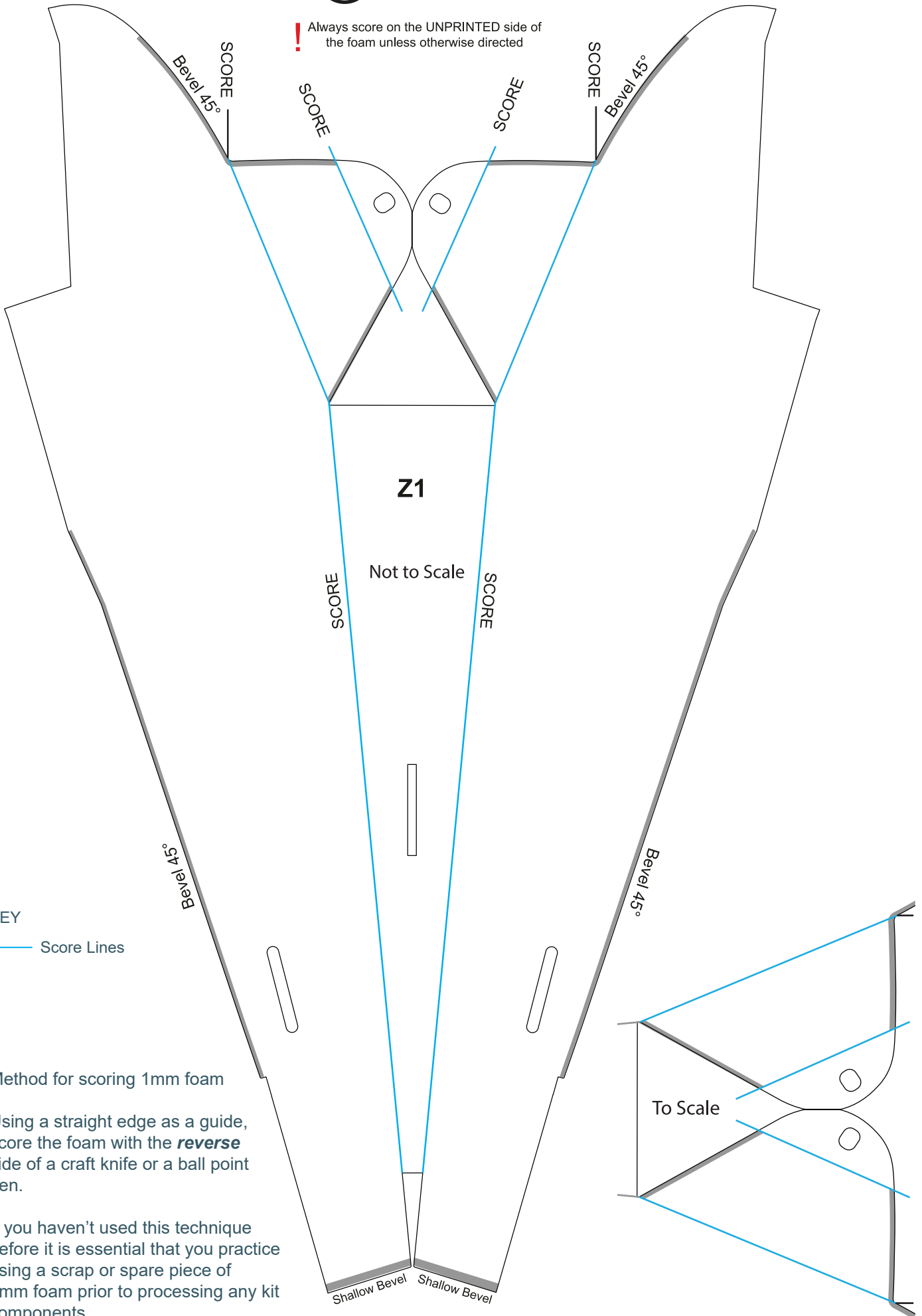

KEY
 — Score Lines

Method for scoring 1mm foam

Using a straight edge as a guide, score the foam with the **reverse** side of a craft knife or a ball point pen.

If you haven't used this technique before it is essential that you practice using a scrap or spare piece of 1mm foam prior to processing any kit components.

SCORING & BEVELING GUIDE #2

Method for scoring 1mm foam

Using a straight edge as a guide, score the foam with the **reverse** side of a craft knife or a ball point pen.

If you haven't used this technique before it is essential that you practice using a scrap or spare piece of 1mm foam prior to processing any kit components.

KEY

— Score Lines

! Always score on the UNPRINTED side of the foam unless otherwise directed

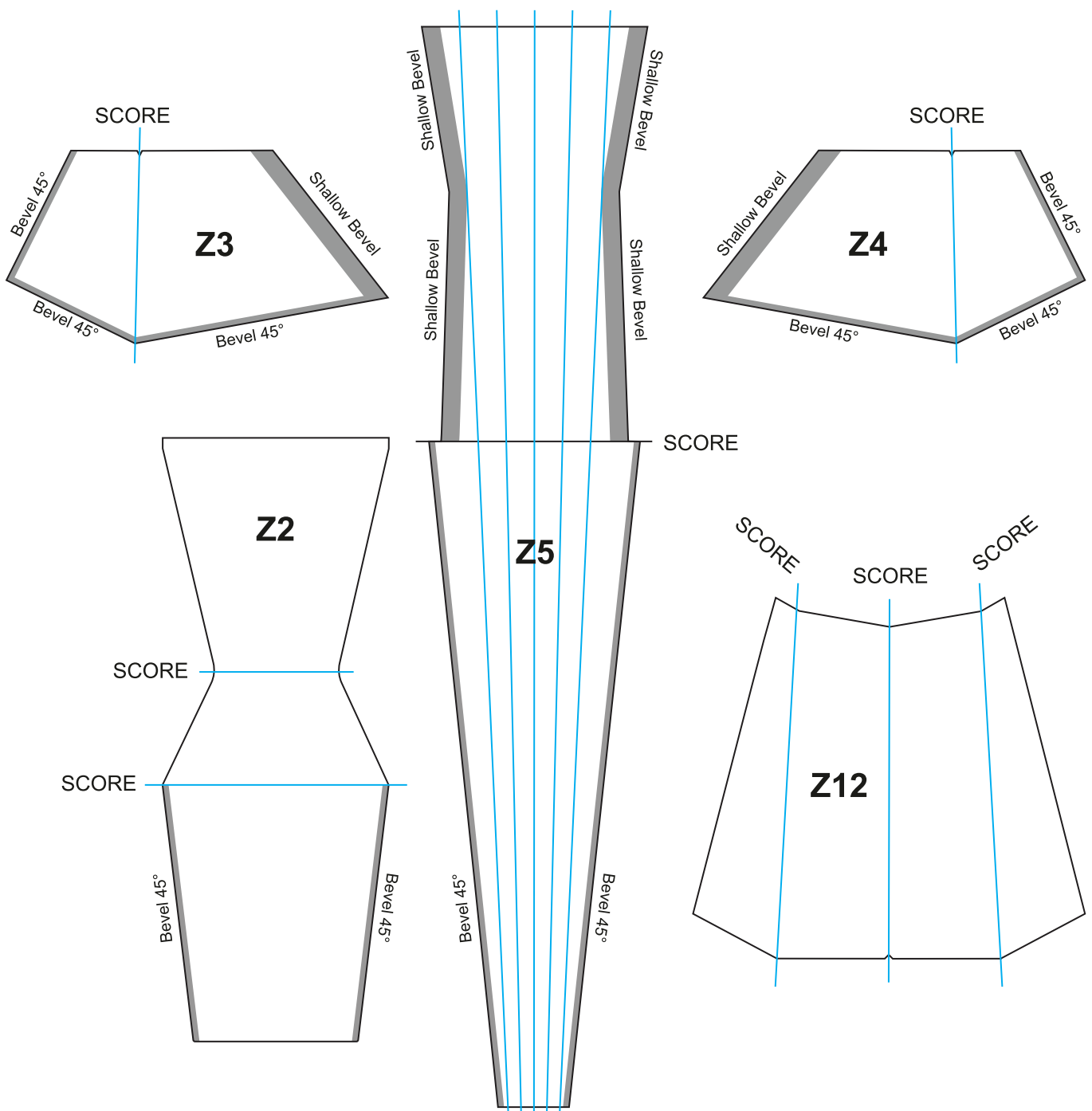



No scoring on Z10 or Z11

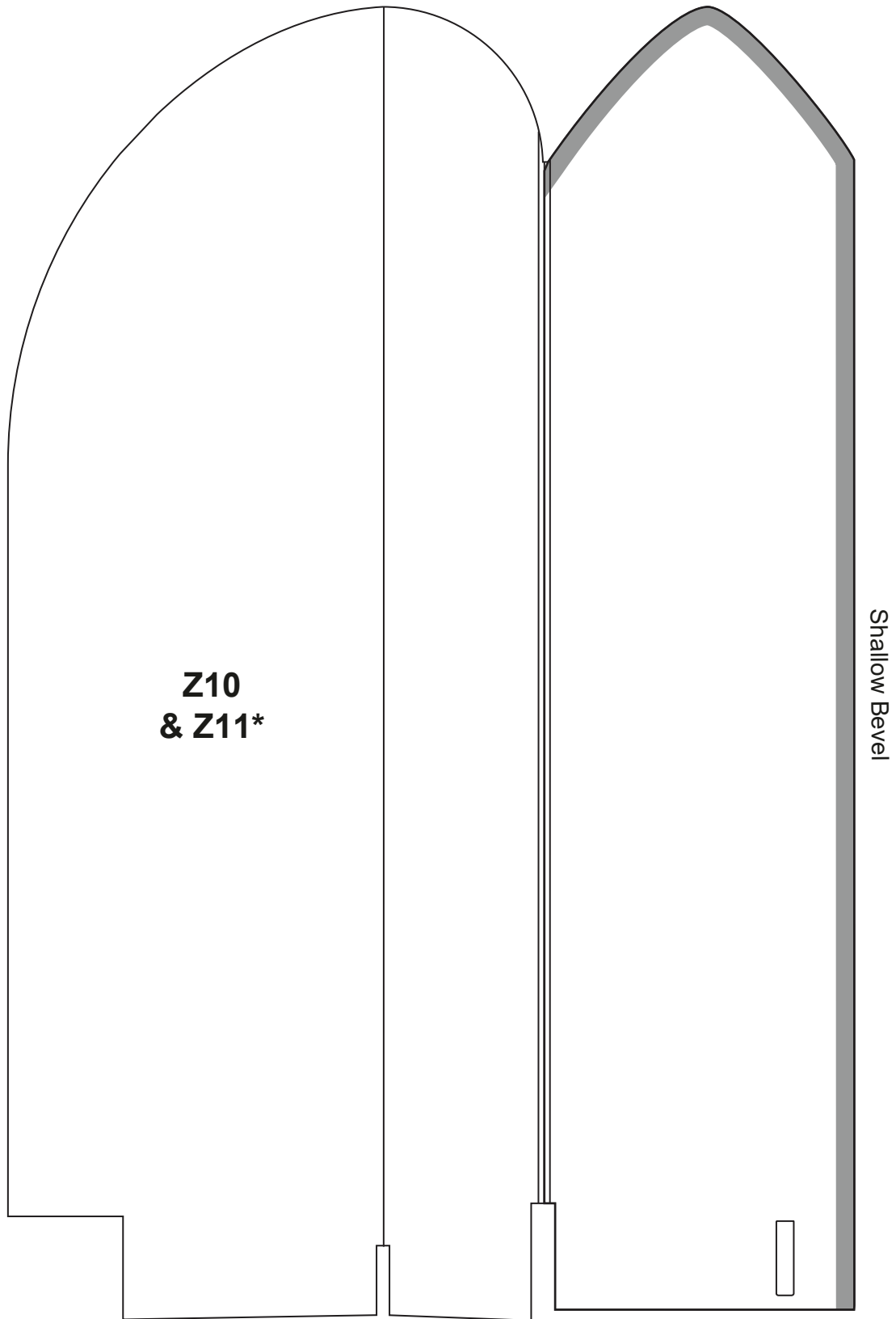

* Z11 not illustrated



No scoring on Z10 or Z11

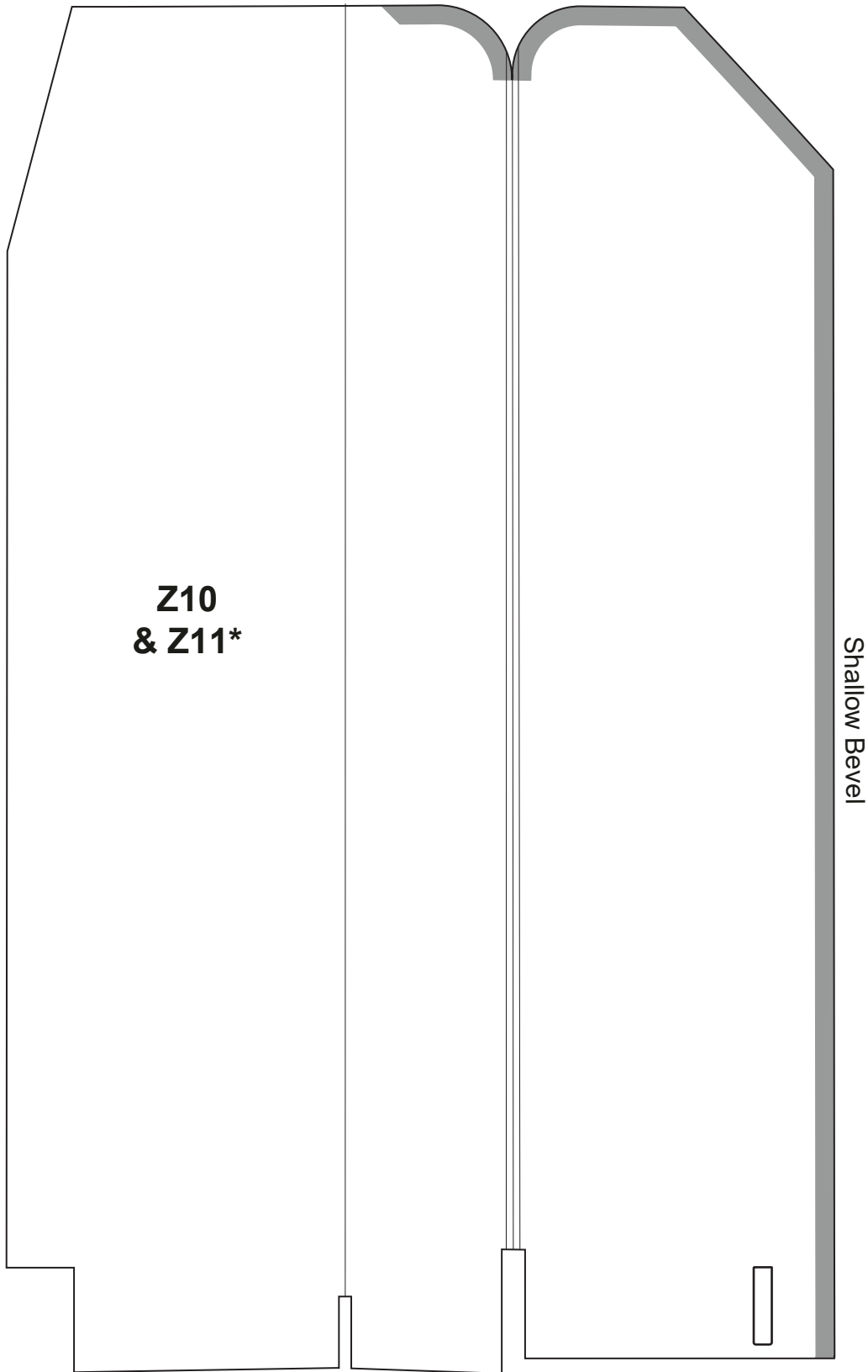

* Z11 not illustrated

STAGE 1 AIRFRAME



The plastic parts used in the airframe are there to increase the strength of the structure in vital areas whilst still providing some flexibility.



Apply a thin layer of adhesive to the plastic part and attach immediately to allow some wiggle time to get the parts lined up. Set aside to cure.

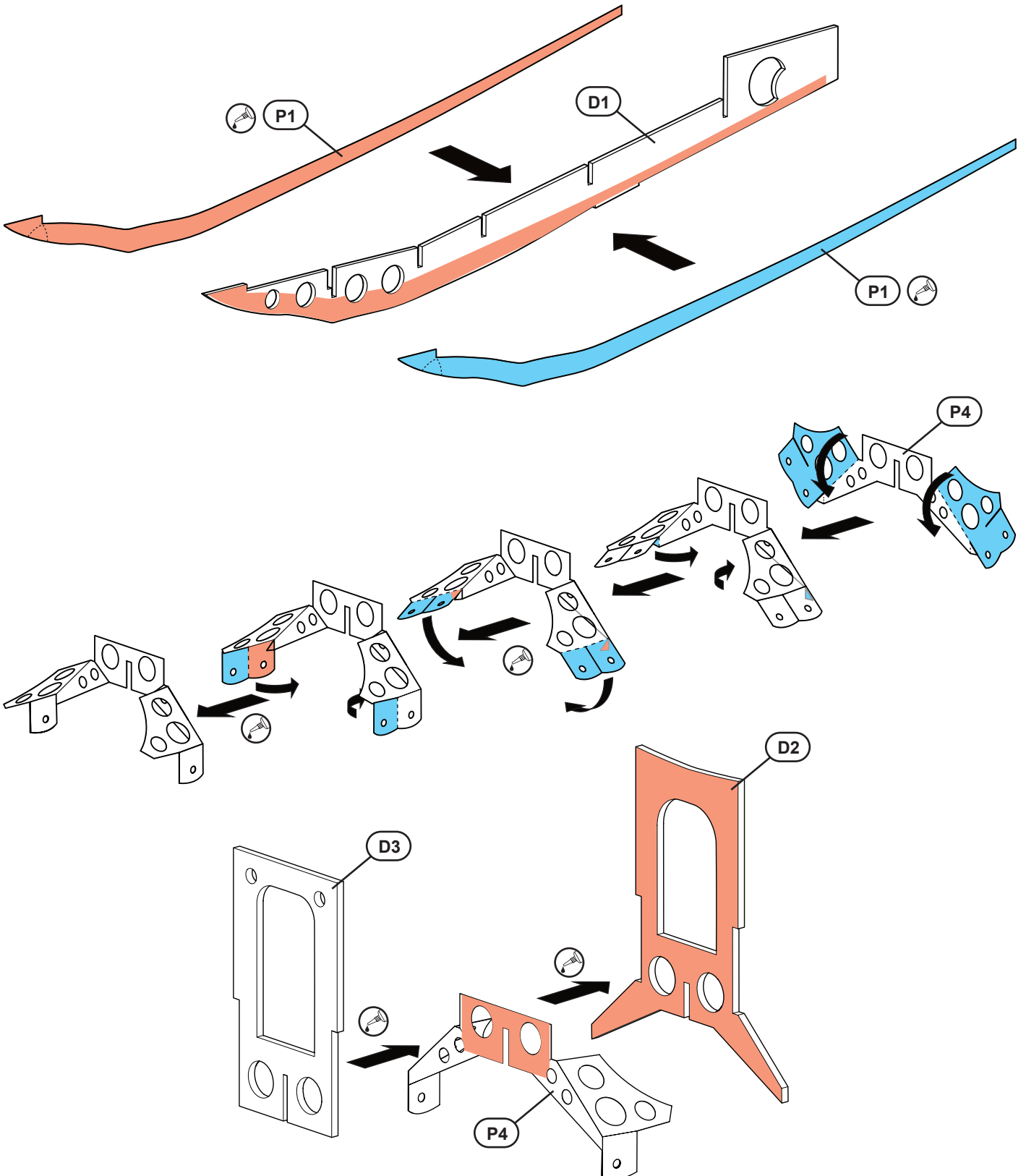

STAGE 1 AIRFRAME

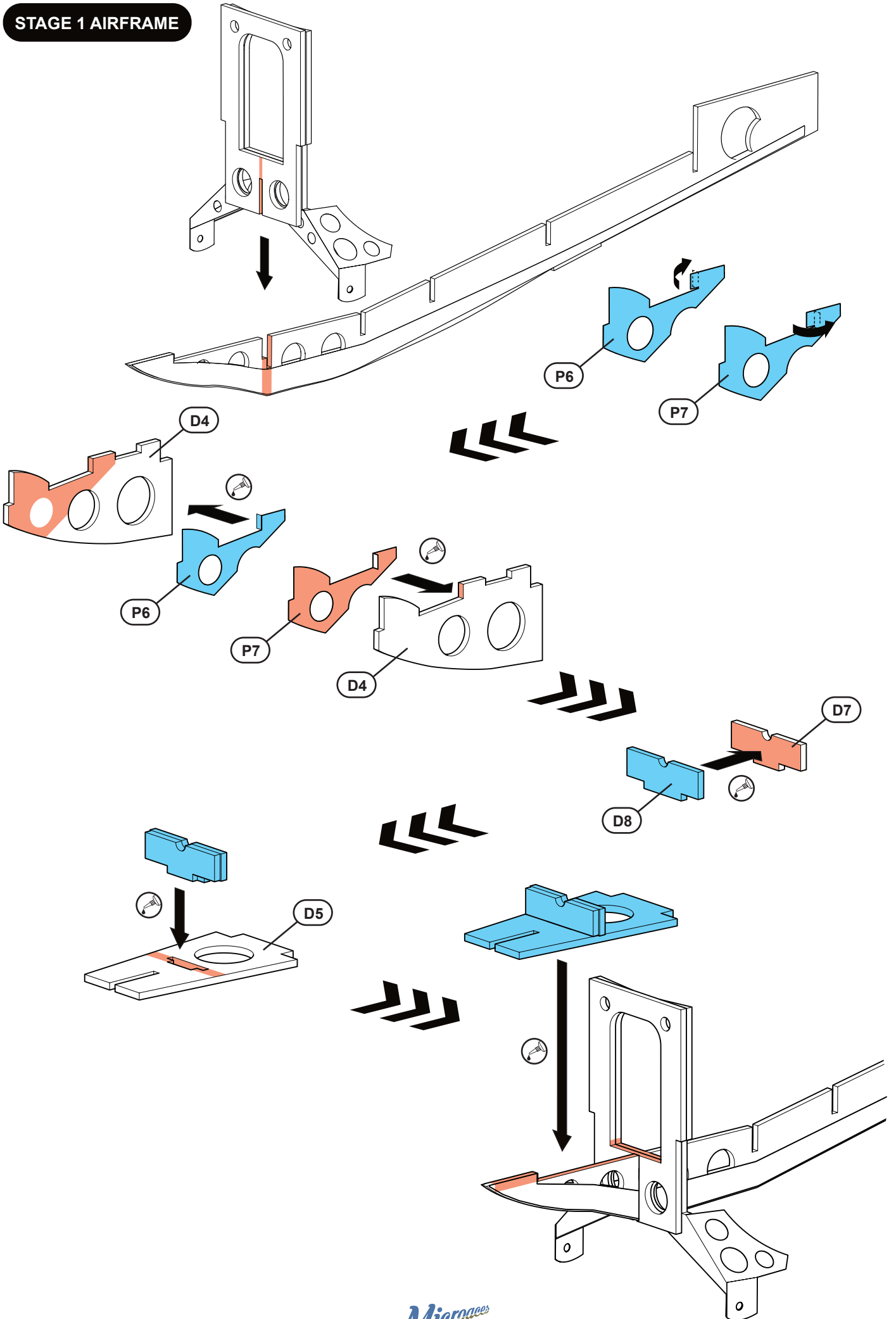

STAGE 1 AIRFRAME

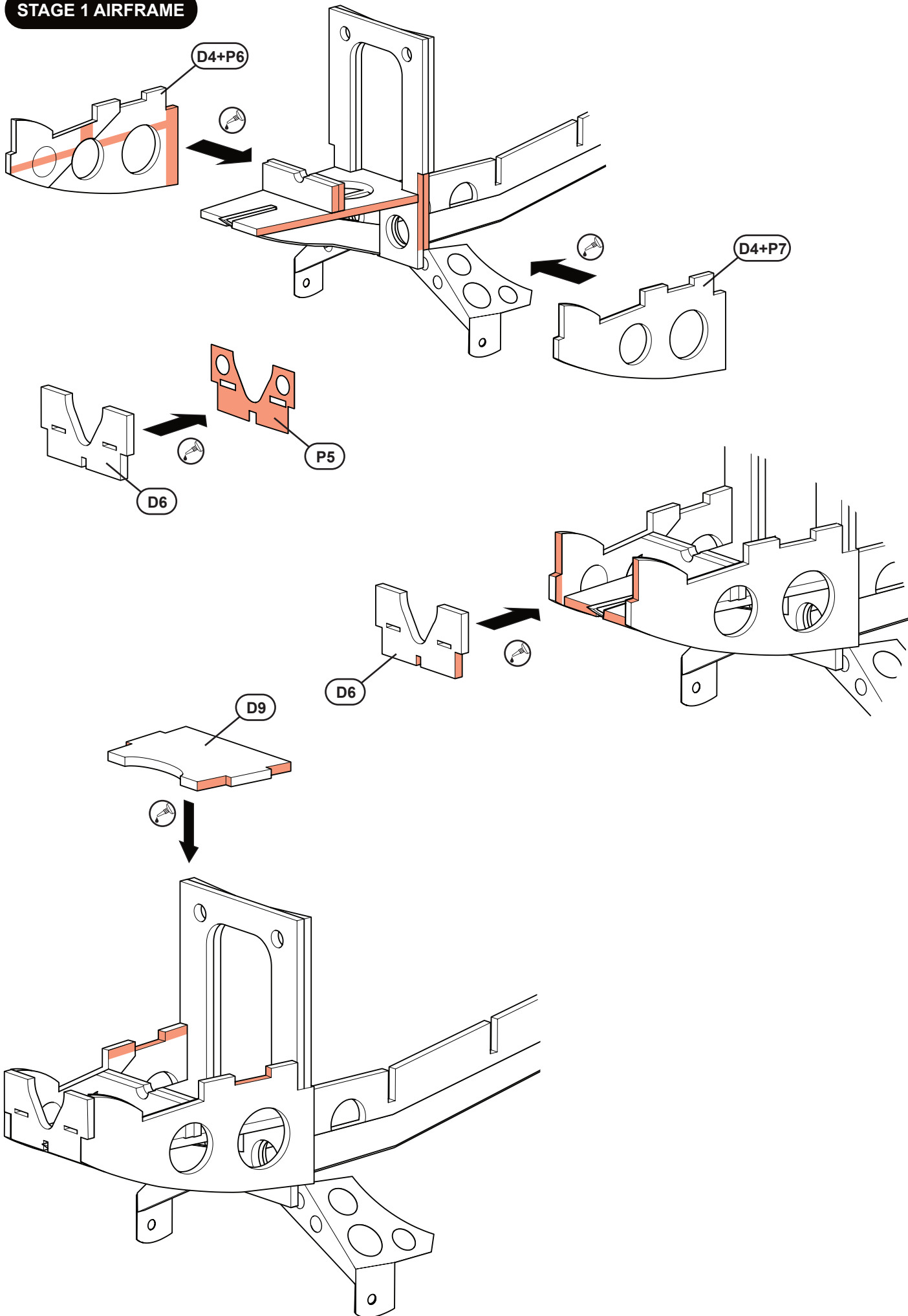

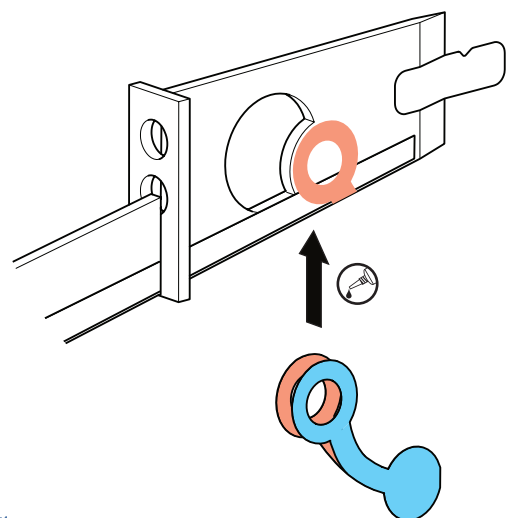
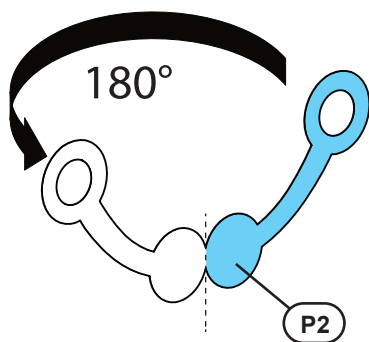
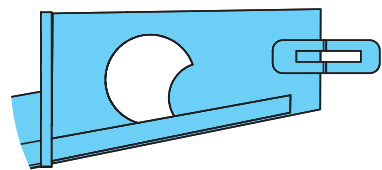
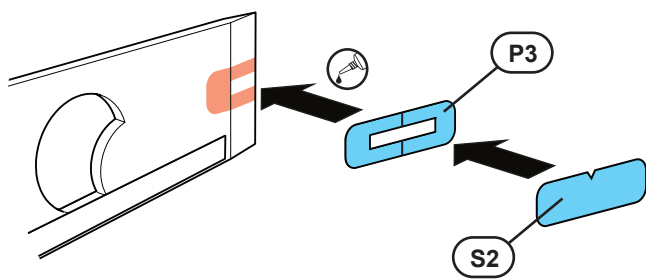
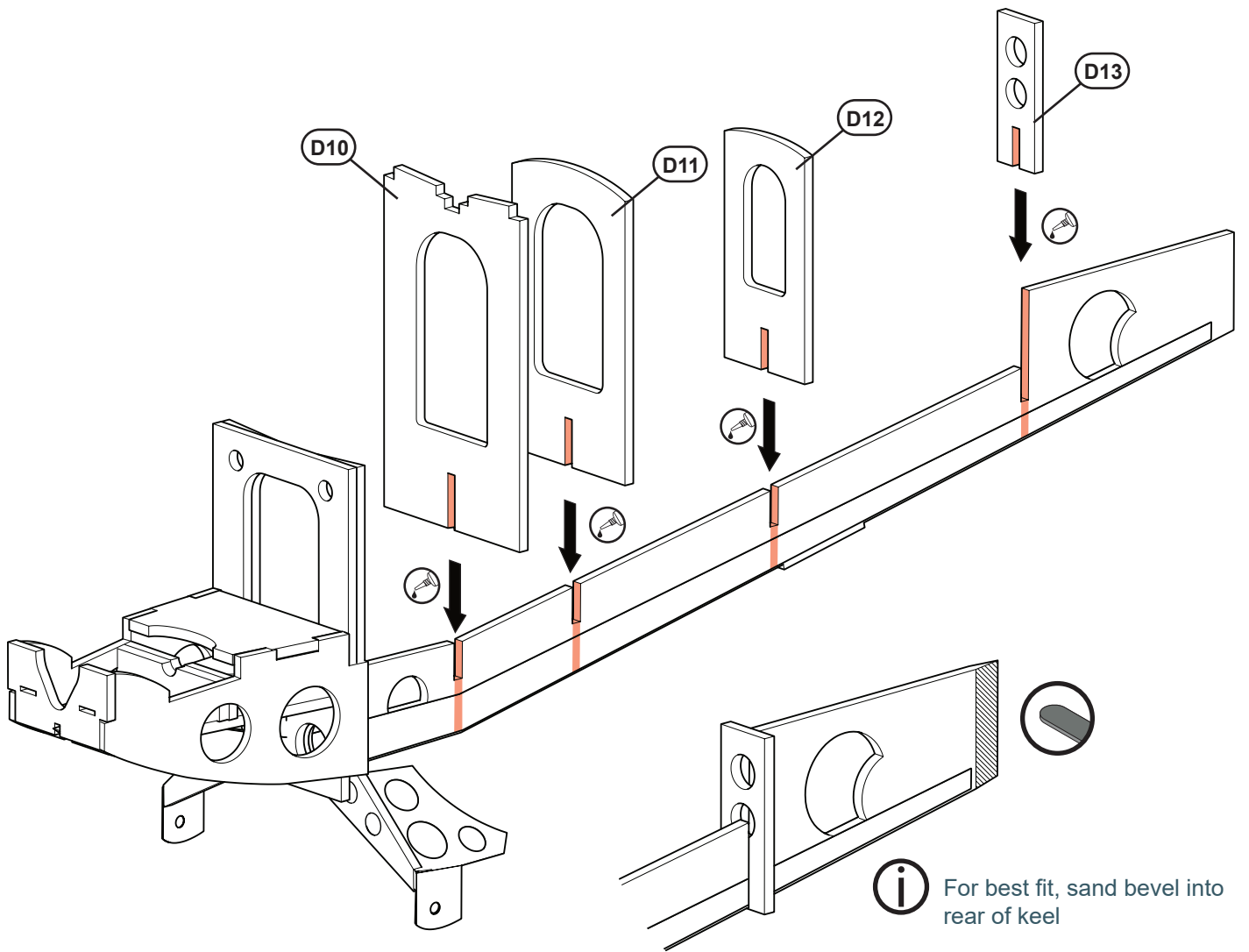

STAGE 1 AIRFRAME

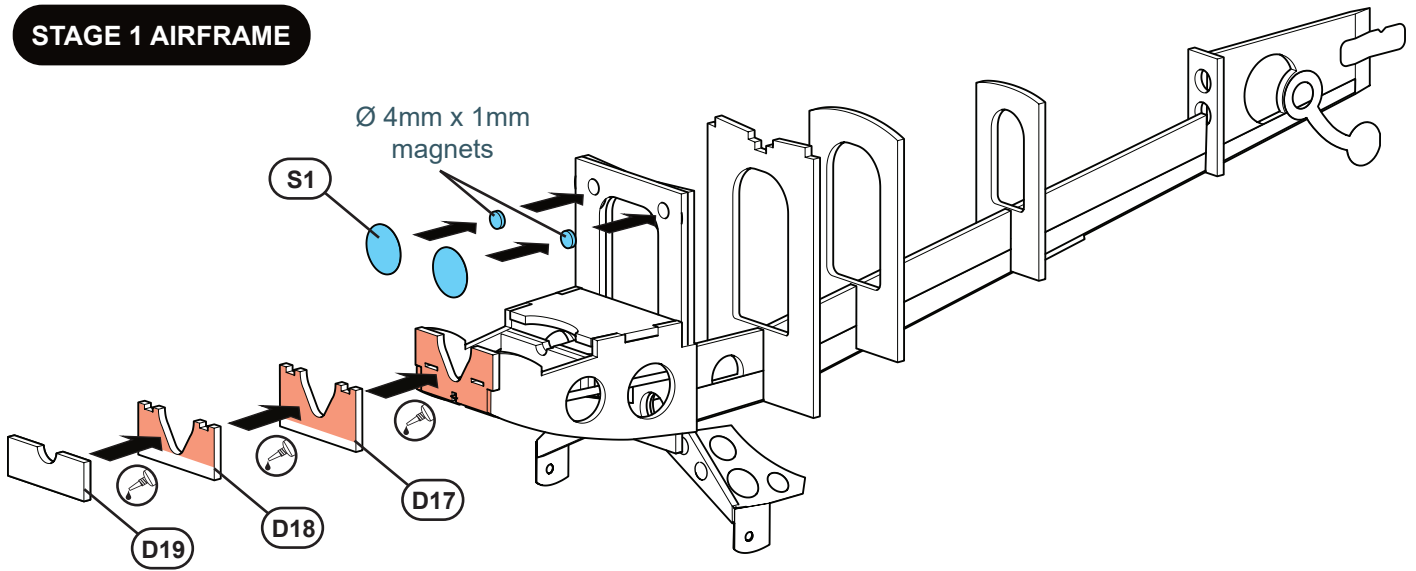

STAGE 2 FUSELAGE



Step 1

⚠ Dry fit before gluing

Ø 3mm x 1mm magnets

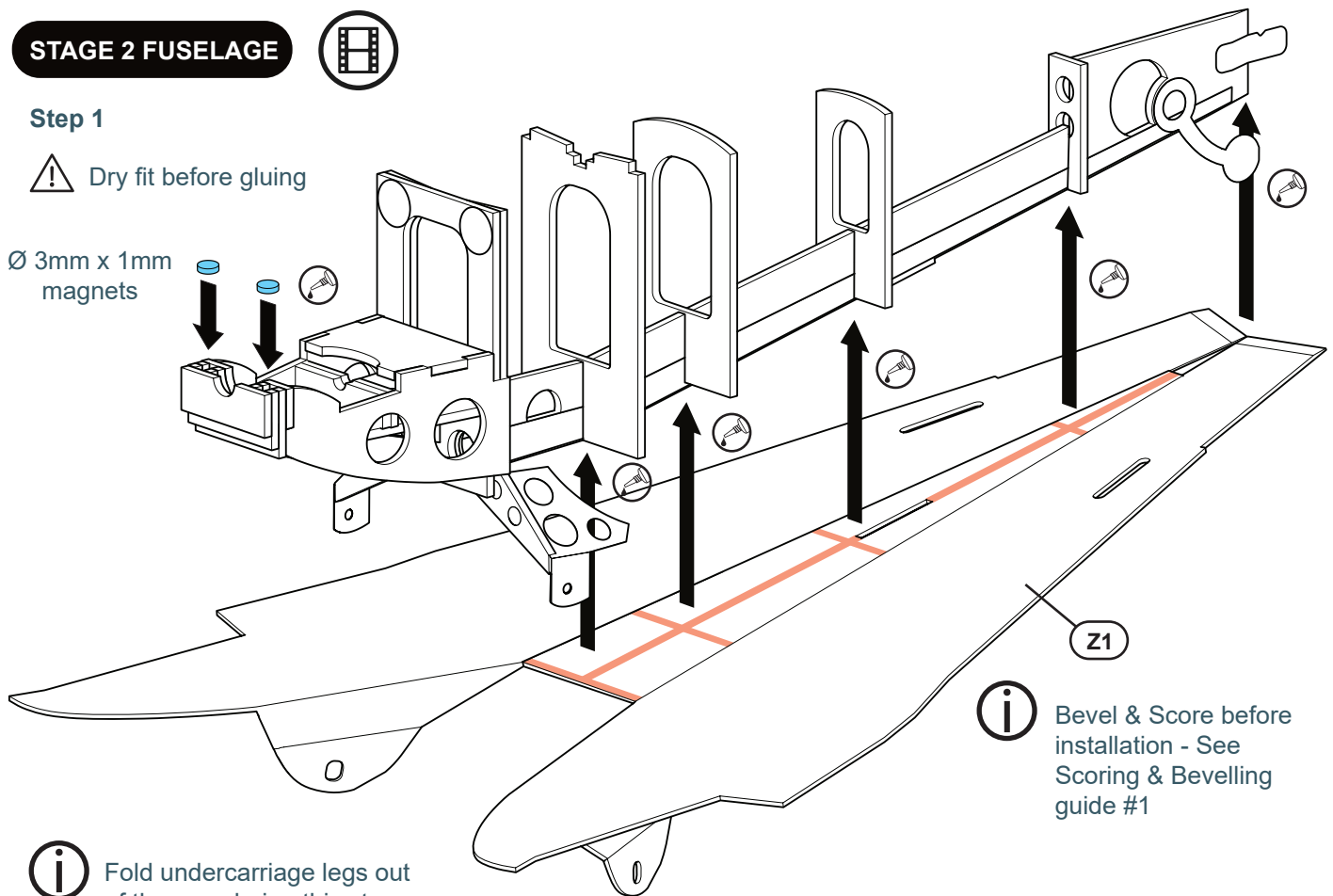

i Bevel & Score before installation - See Scoring & Beveling guide #1

i Fold undercarriage legs out of the way during this stage of the installation.

STAGE 2 FUSELAGE



Step 2

⚠ Dry fit before gluing

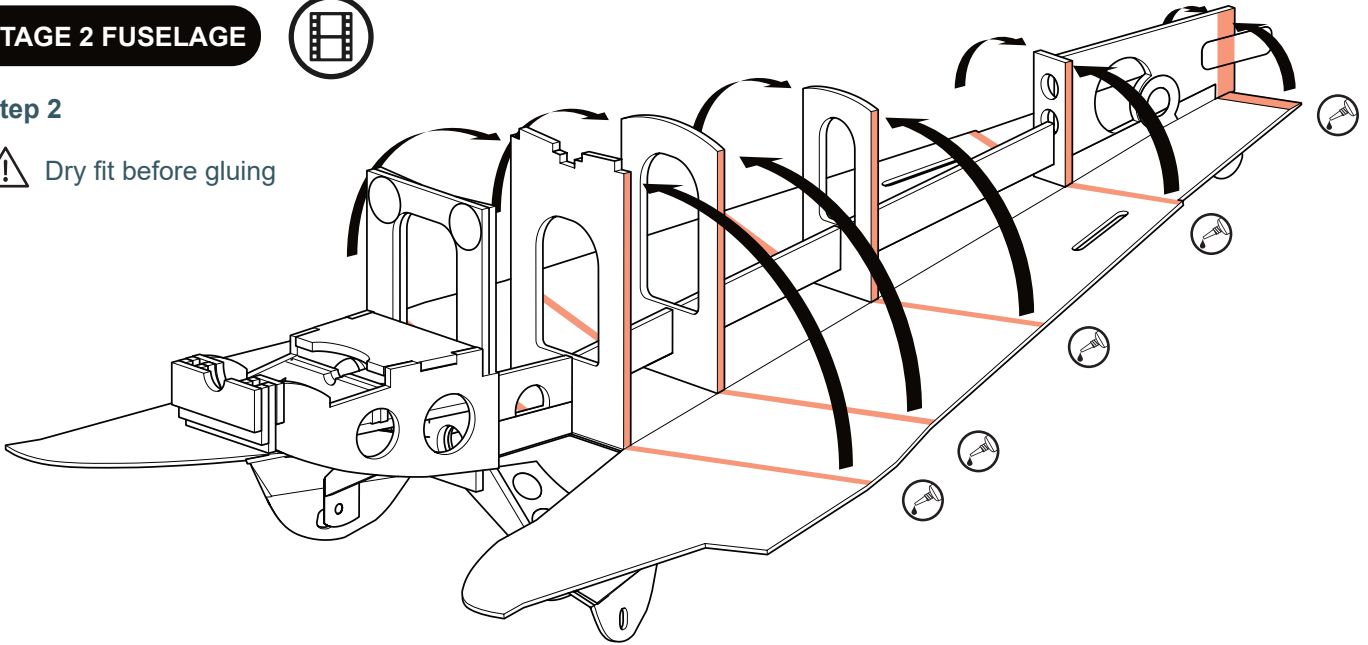

Step 3

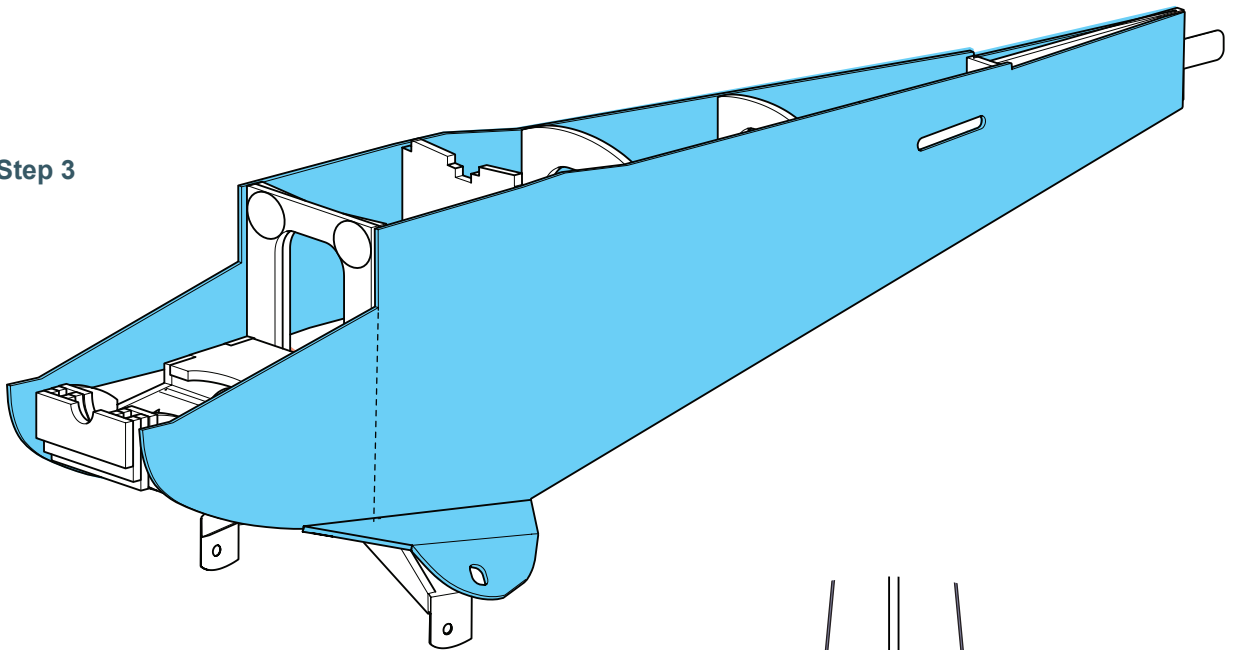

Step 4

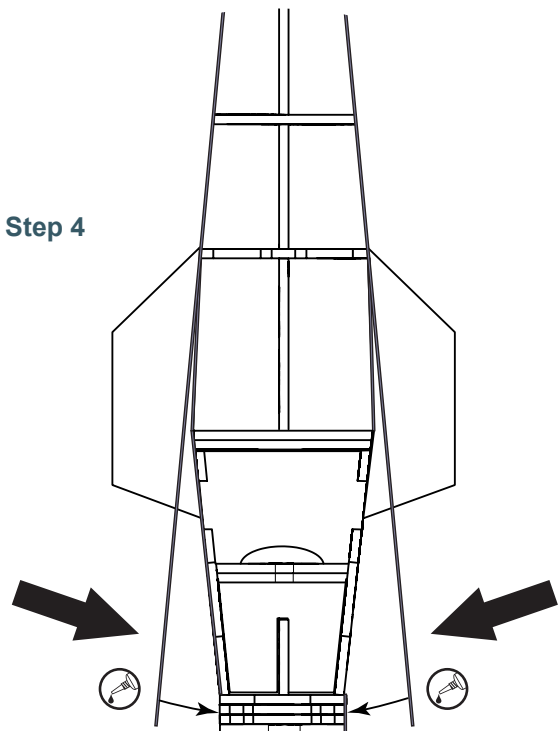

Step 5

⚠ Dry fit before gluing

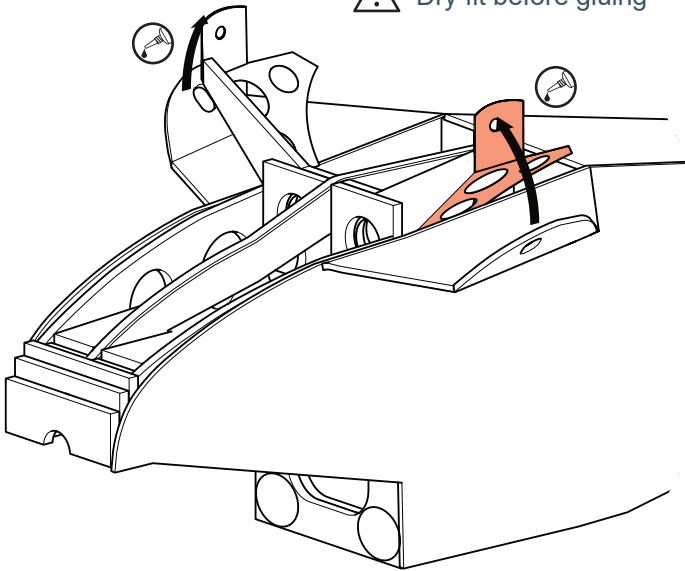

i Bevel & Score before installation - See Scoring & Beveling guide #2

Step 6

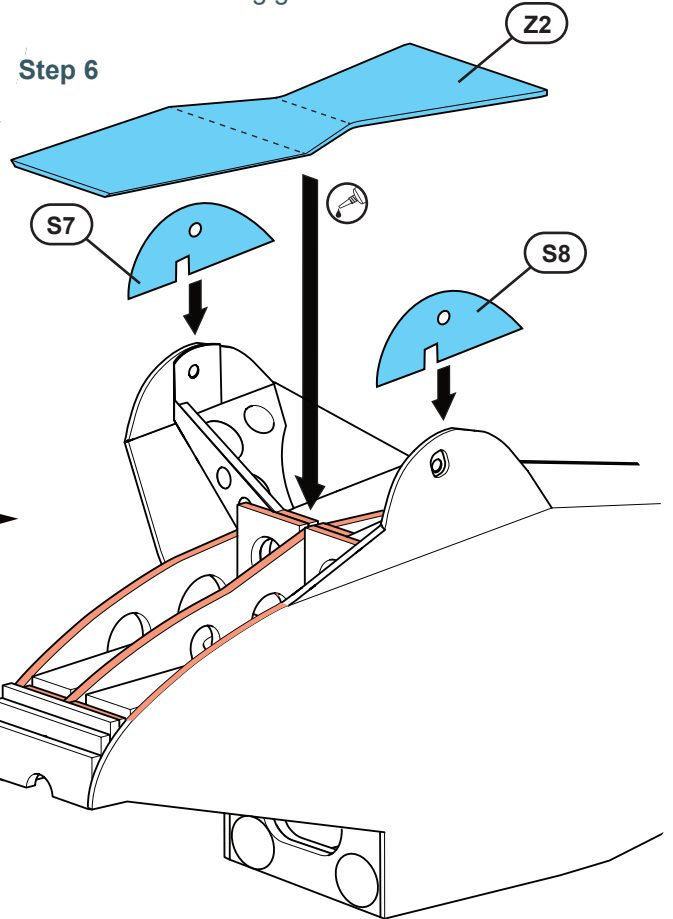

i Bevel & Score before installation - See Scoring & Beveling guide #2

Step 7

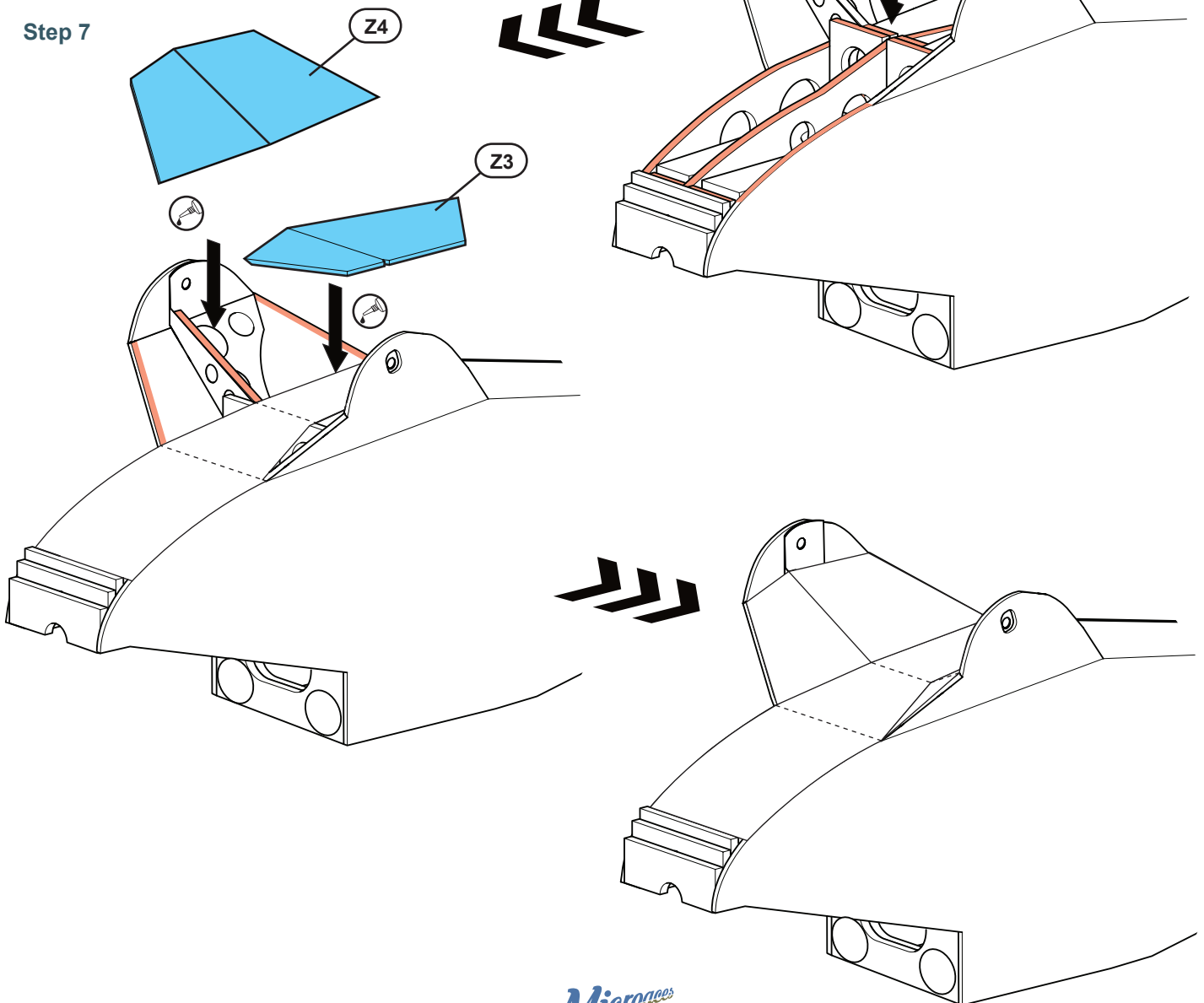

STAGE 3 TAIL

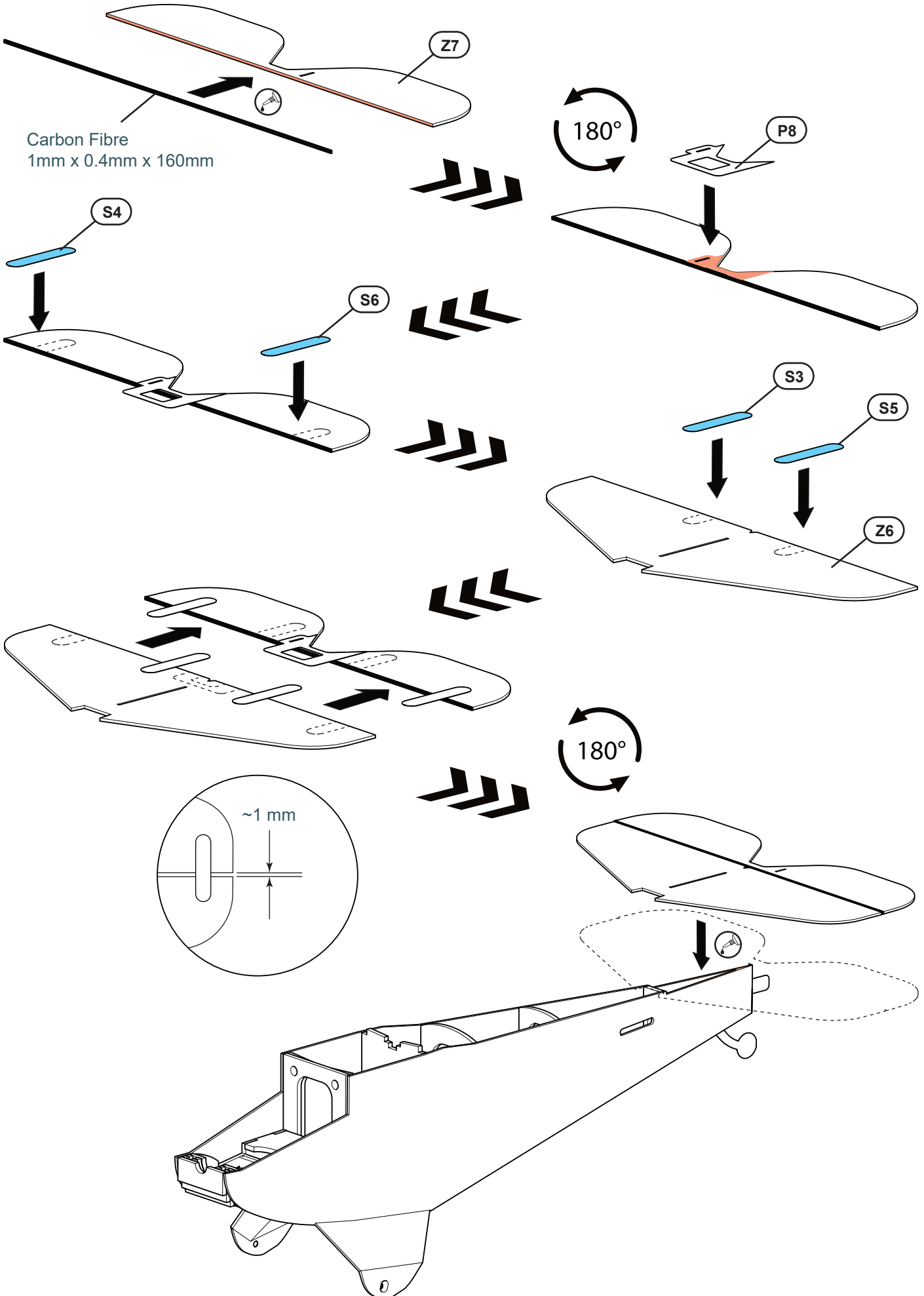

STAGE 4 WING

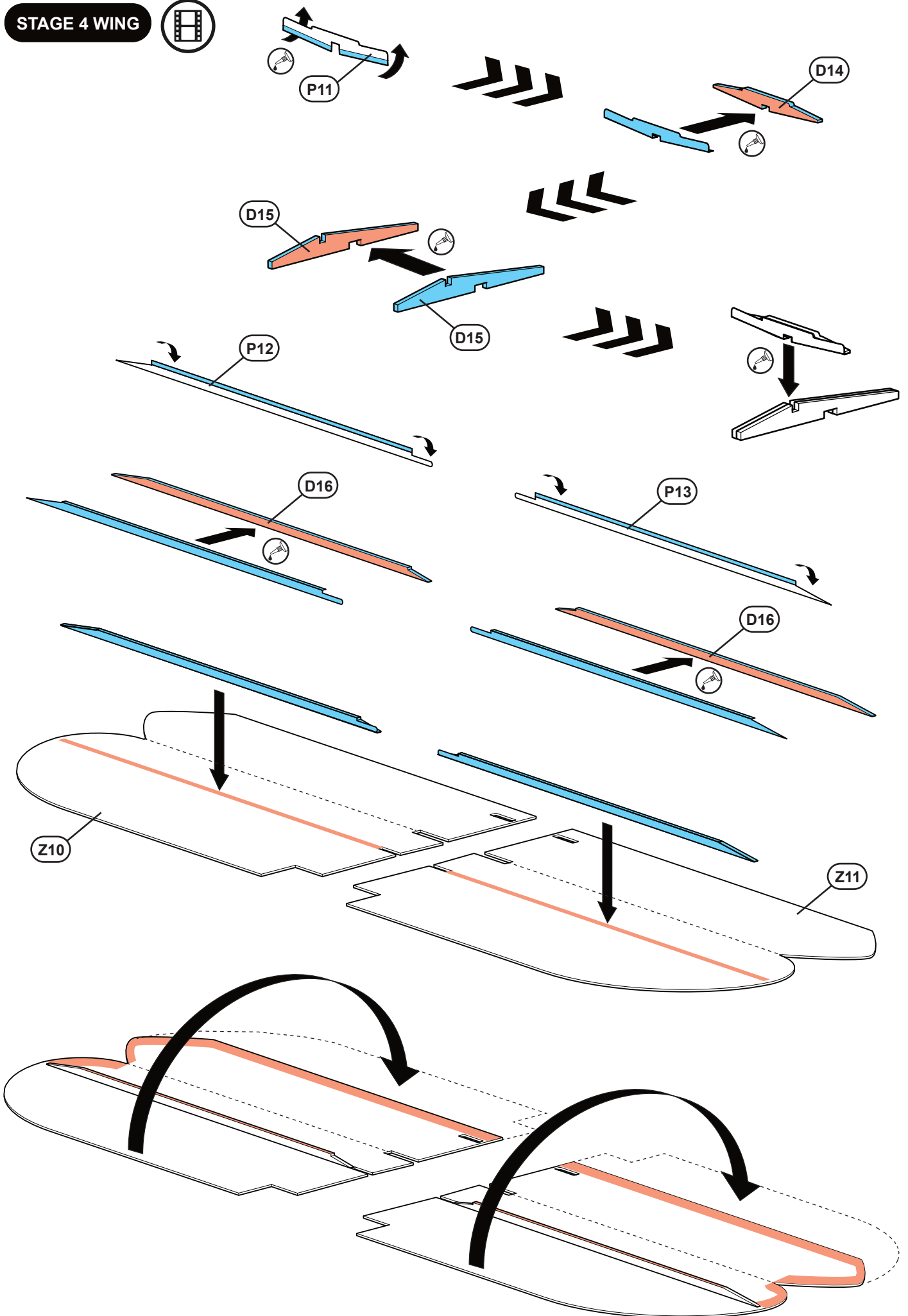

STAGE 4 WING

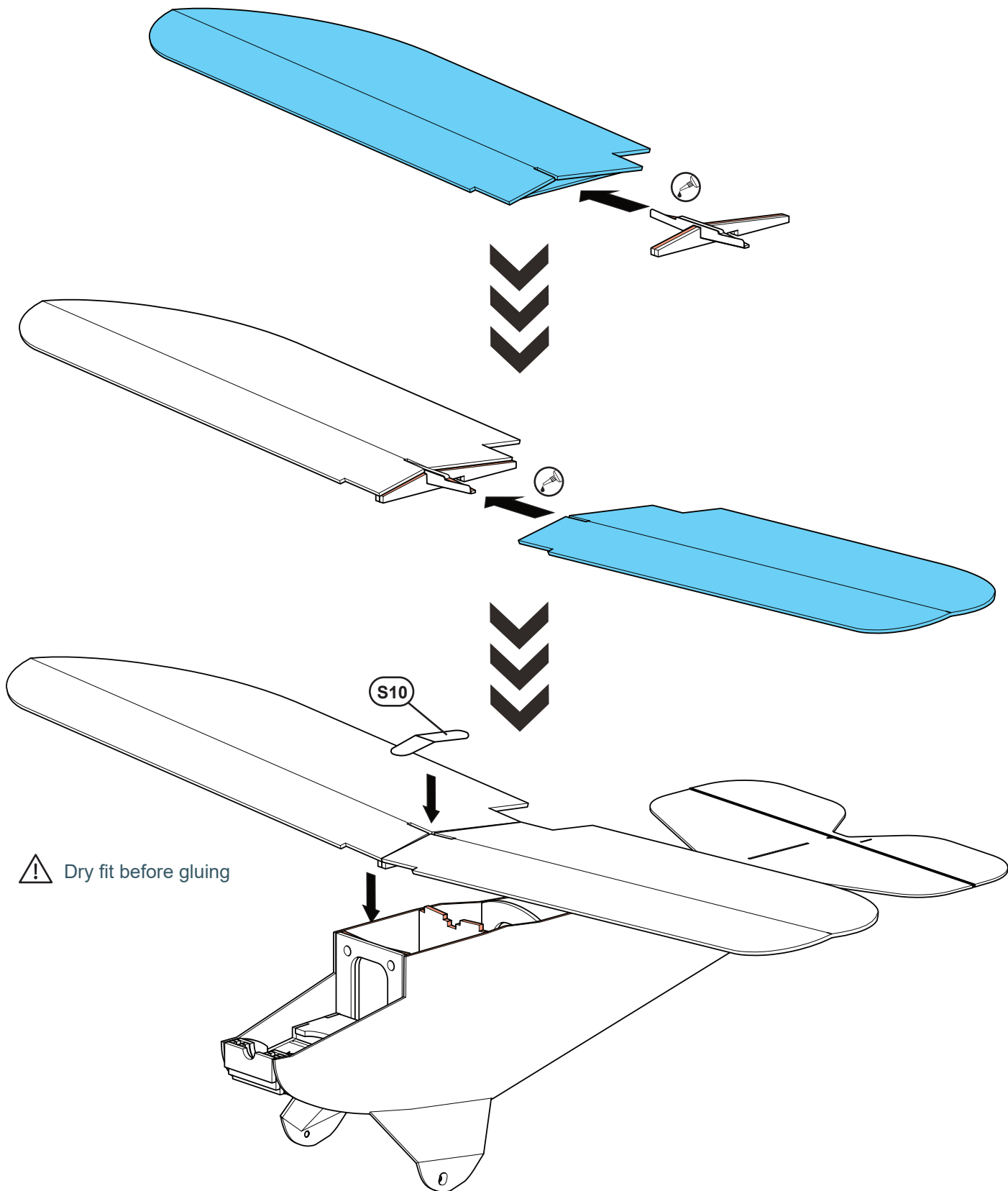

STAGE 5 FUSELAGE



Bevel & Score before installation - See Scoring & Beveling guide #2

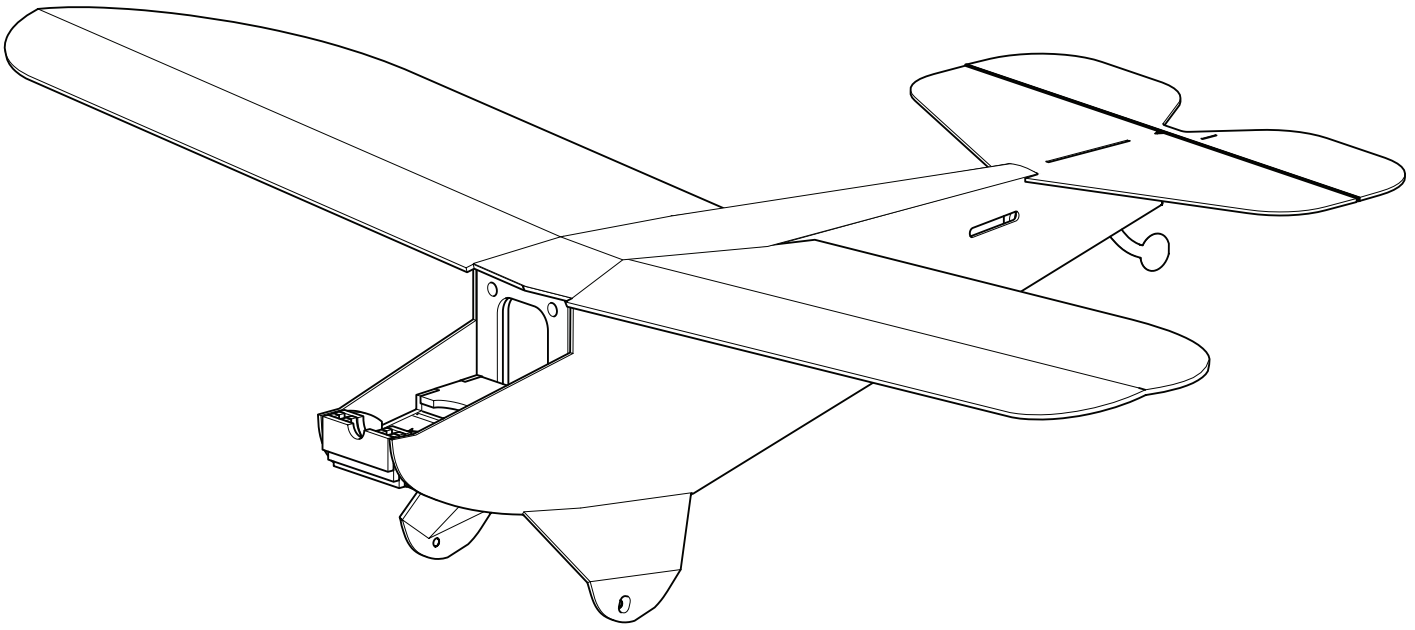
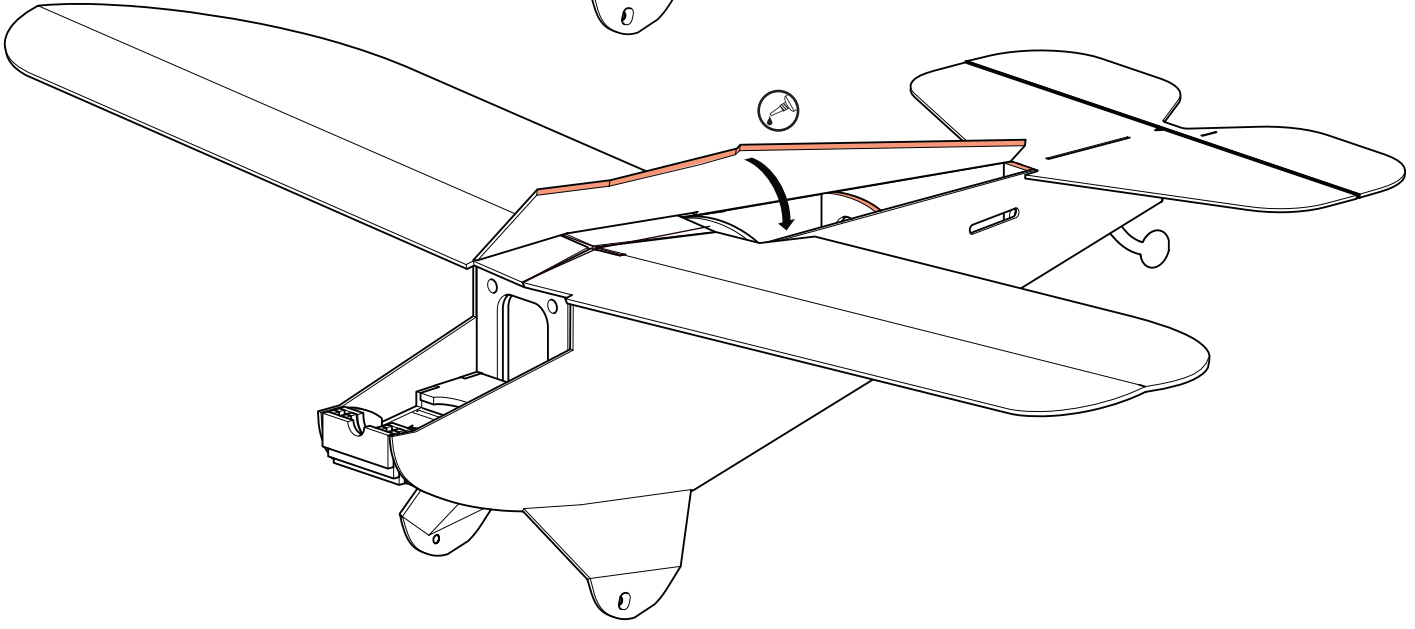
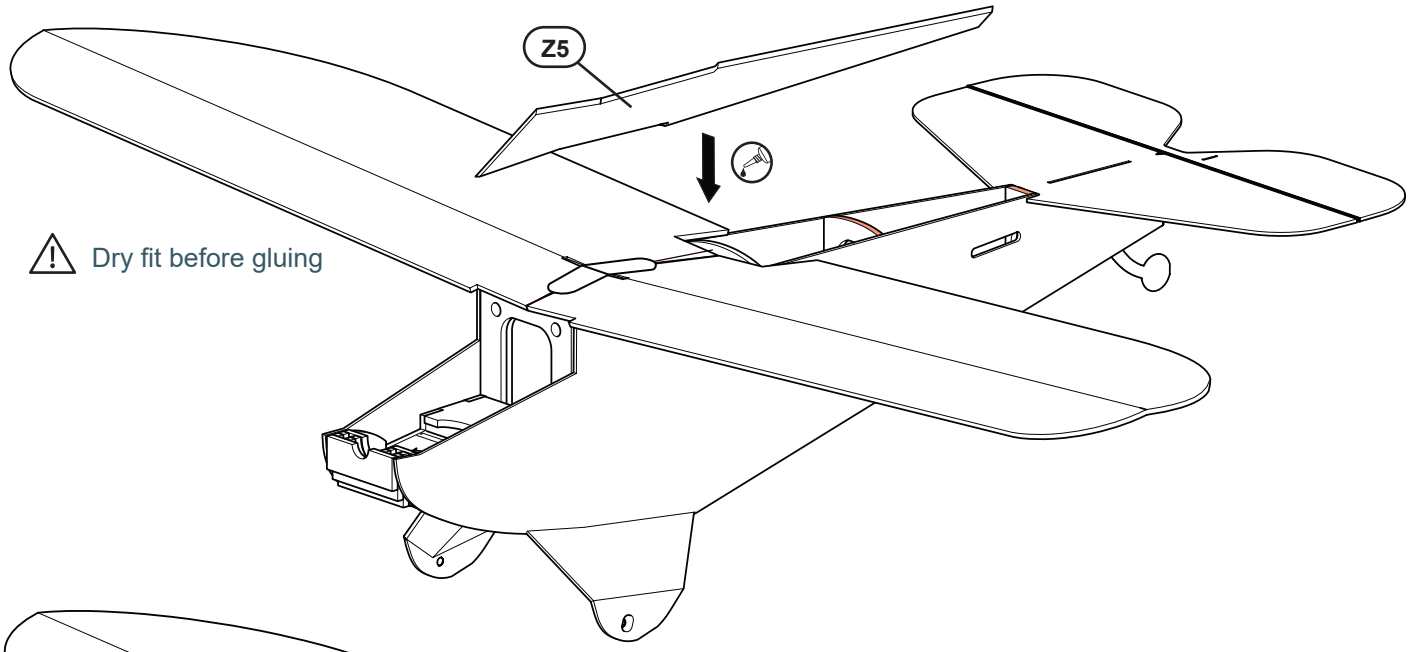

STAGE 6 TAIL

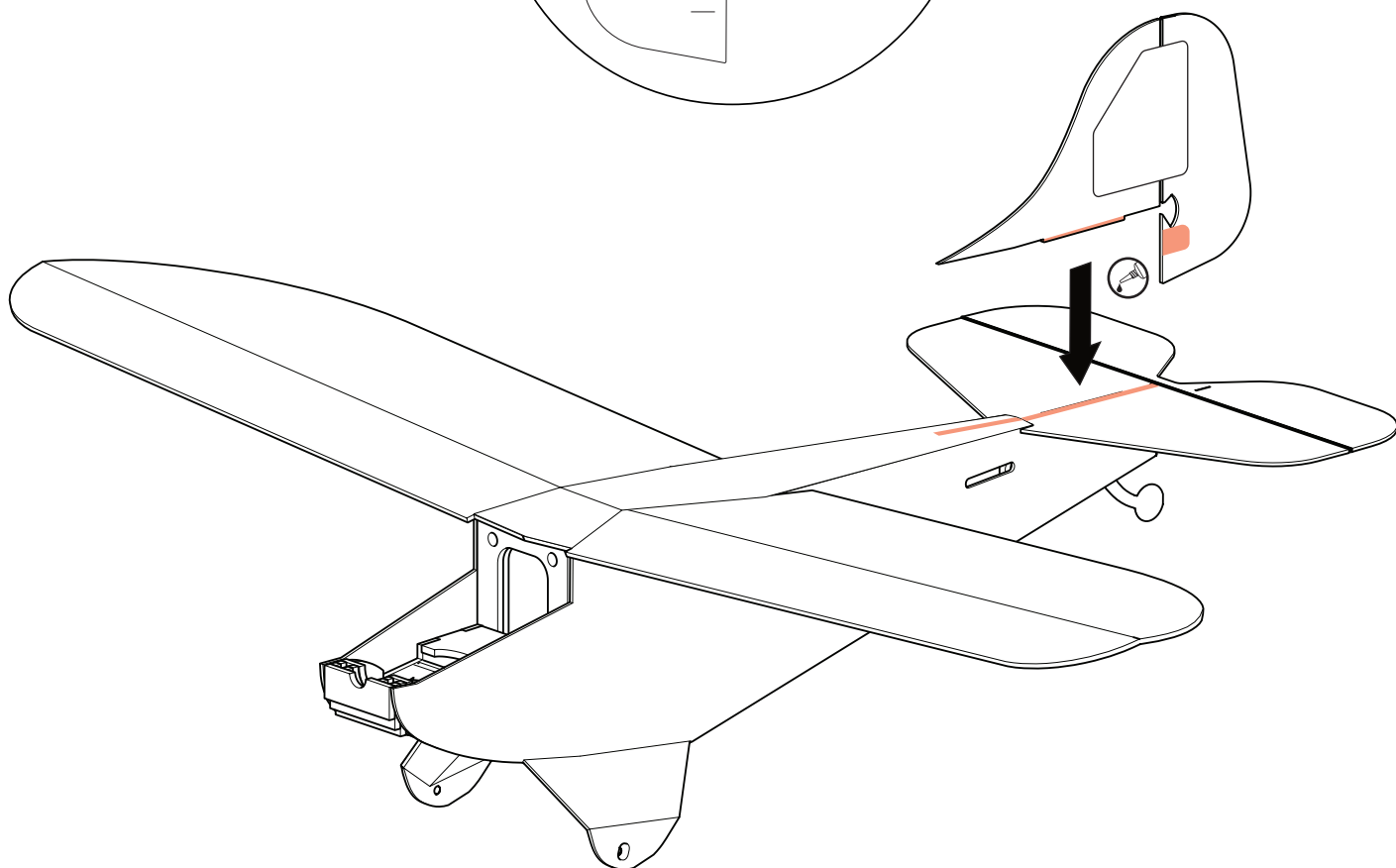
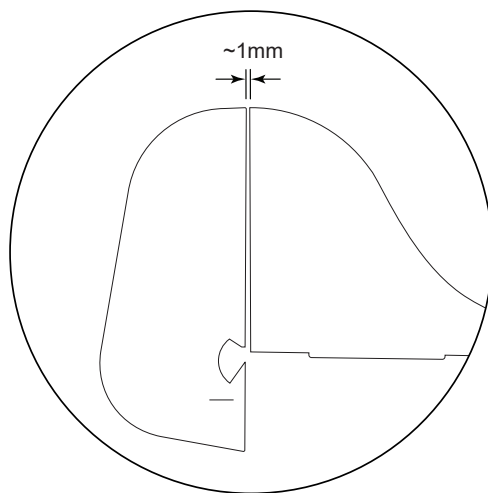
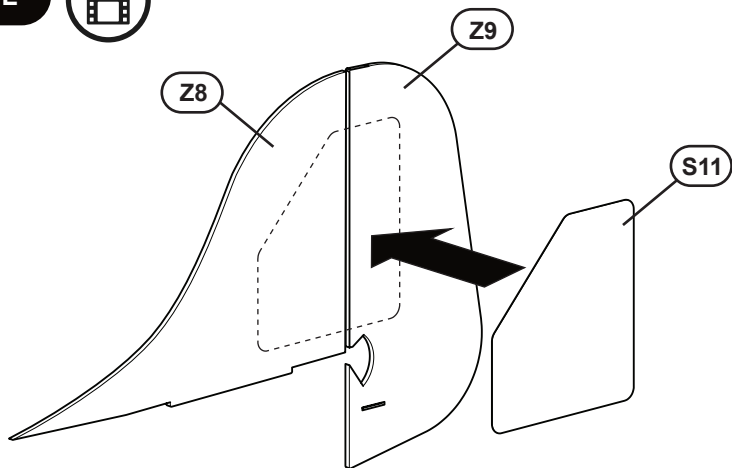

STAGE 7 NOSE

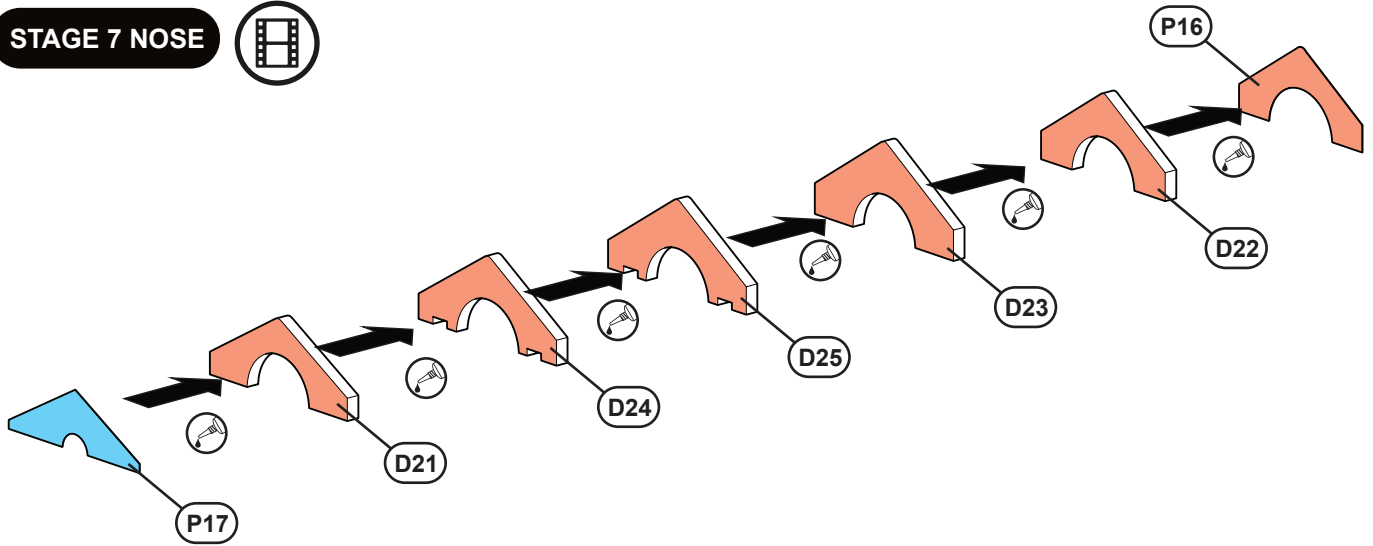

i Ensure the magnets are correctly oriented before installation. Do this by matching them to the magnets installed in the fuselage before installing it here.

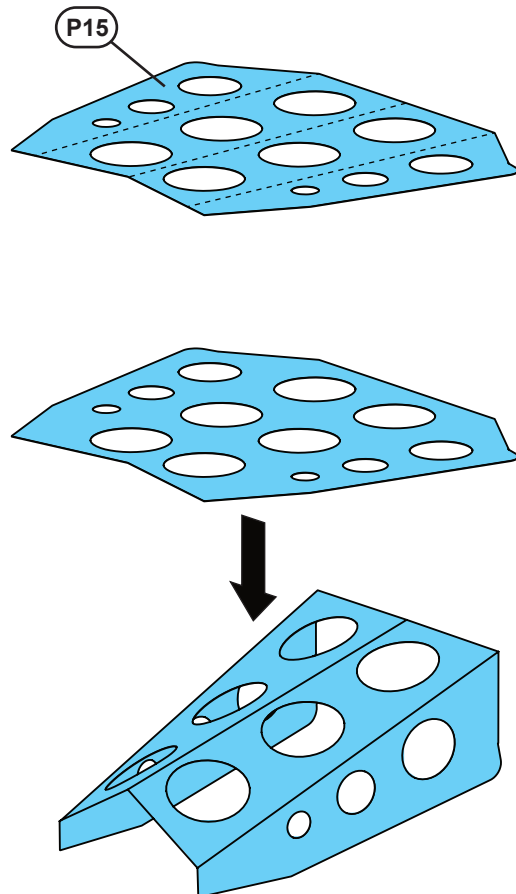
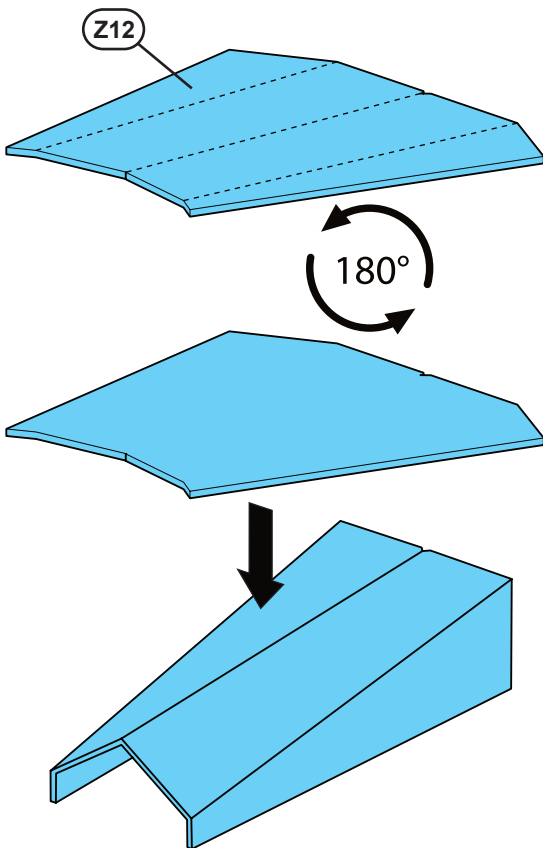
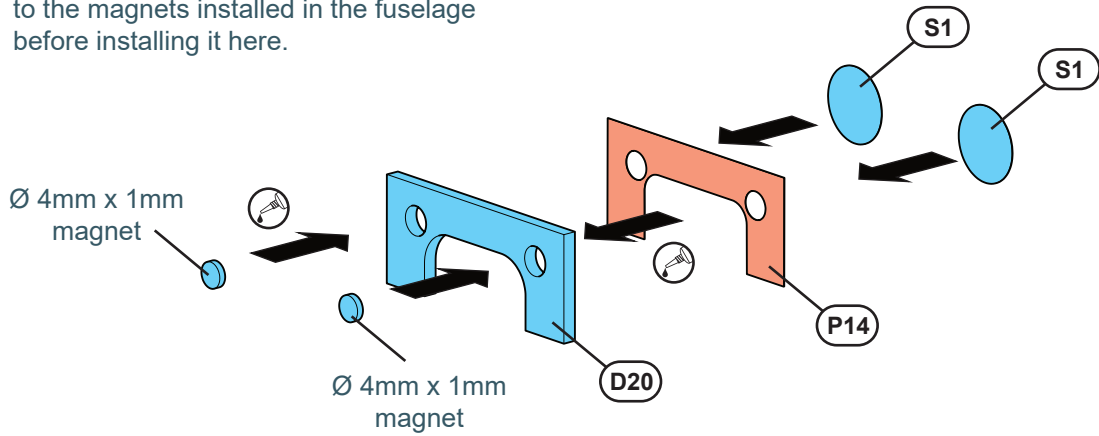

STAGE 7 NOSE

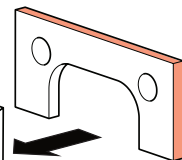
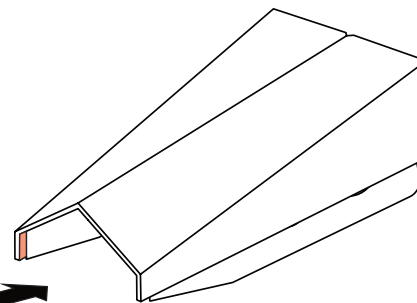
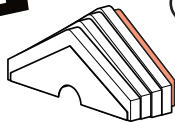
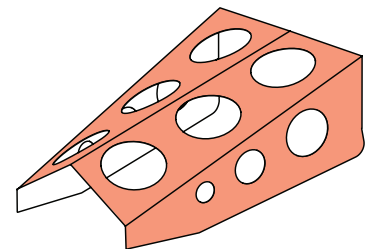
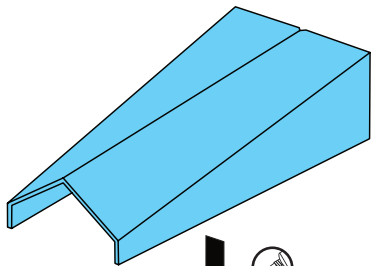

Ø 3mm x 1mm magnets

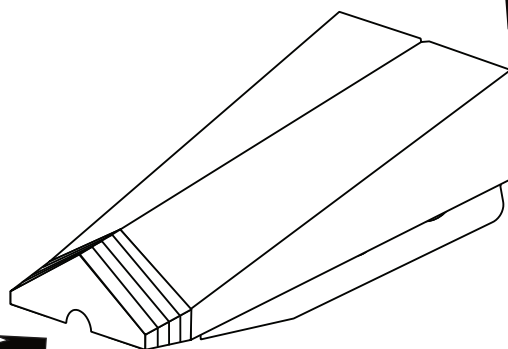
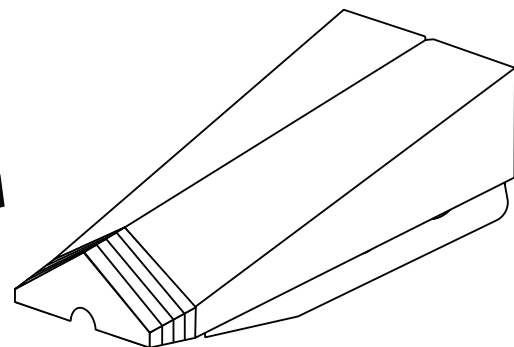
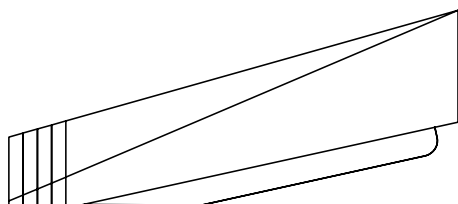
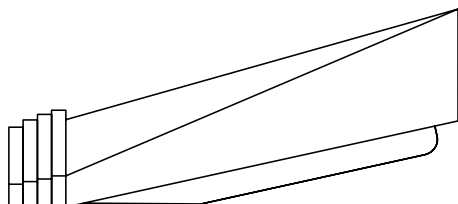
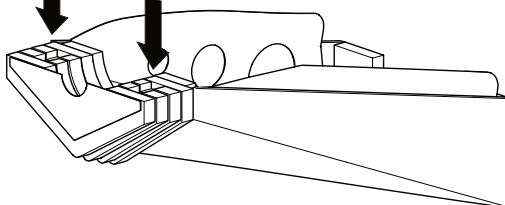
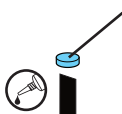

S13

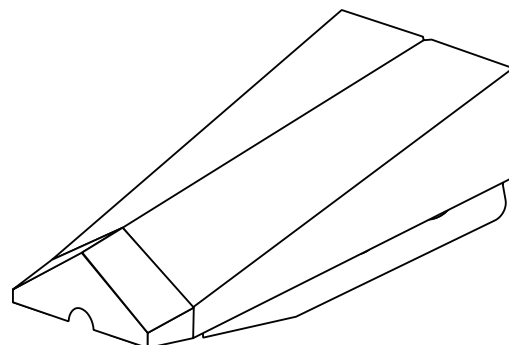
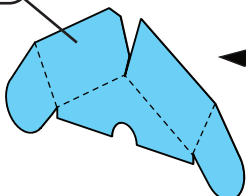

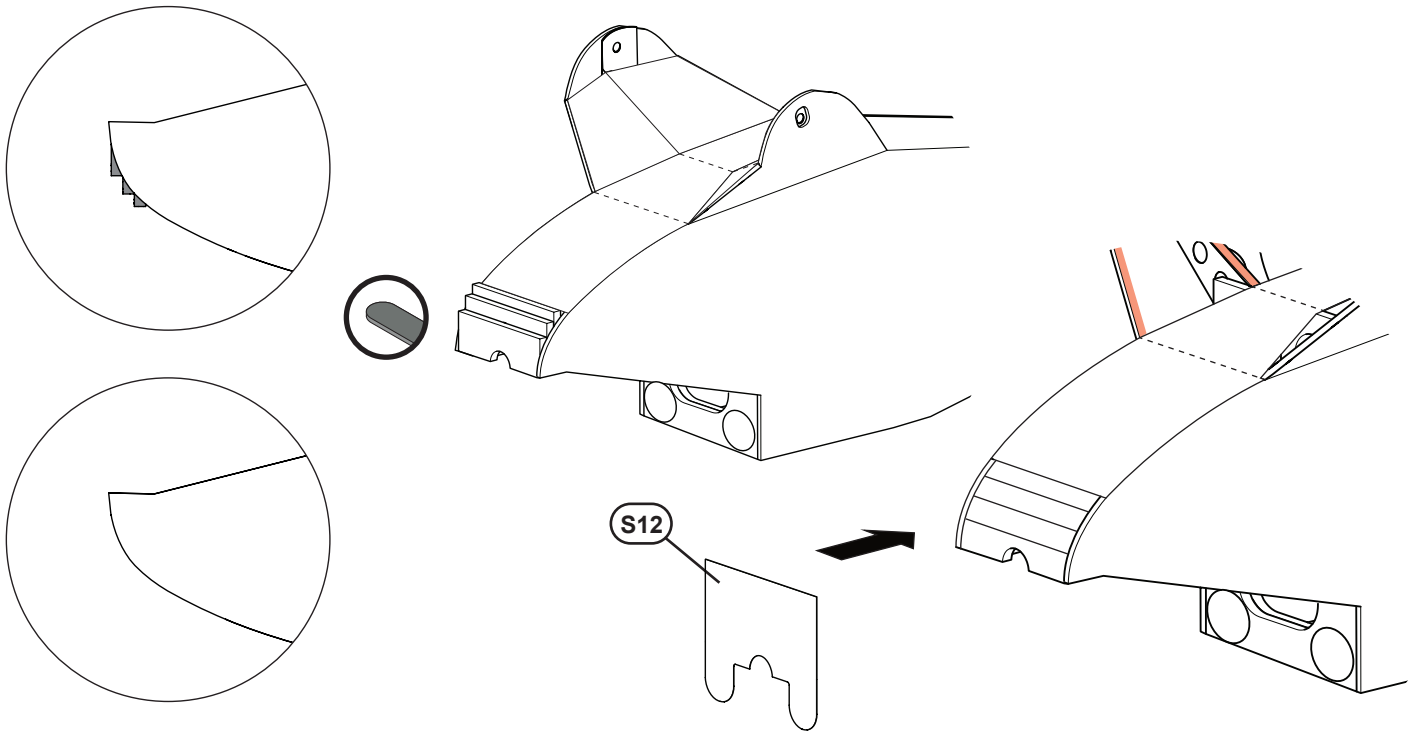

STAGE 8 WHEELS

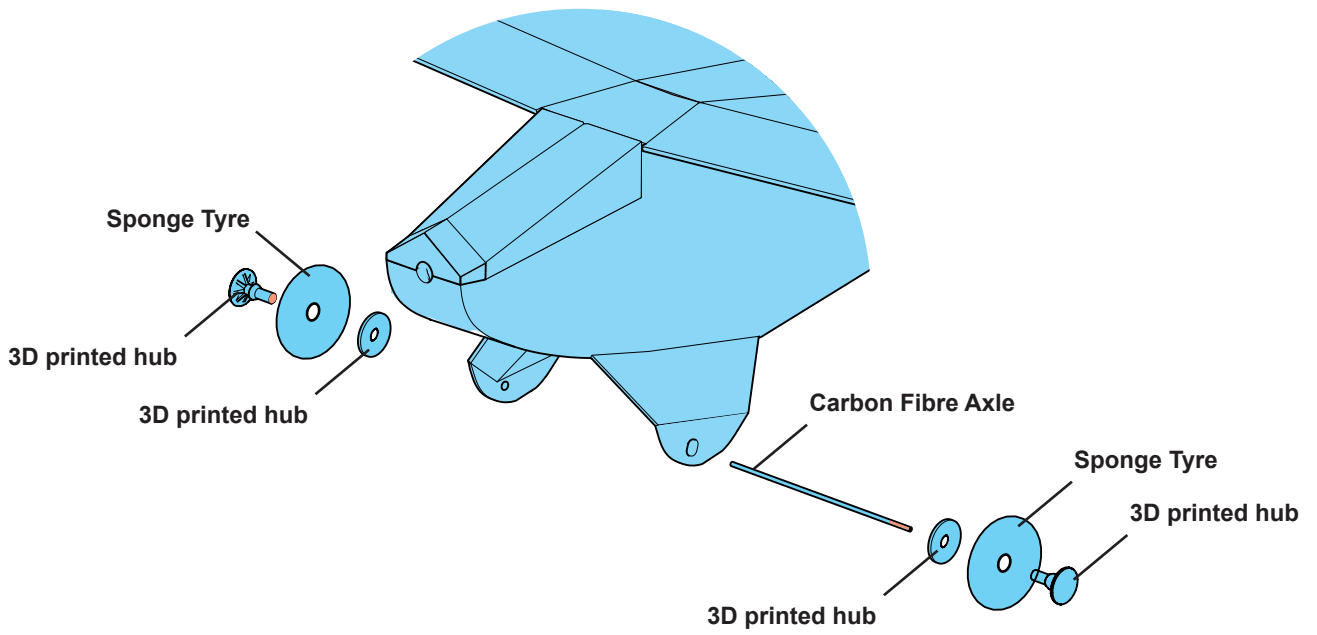

STAGE 9 CONTROLS

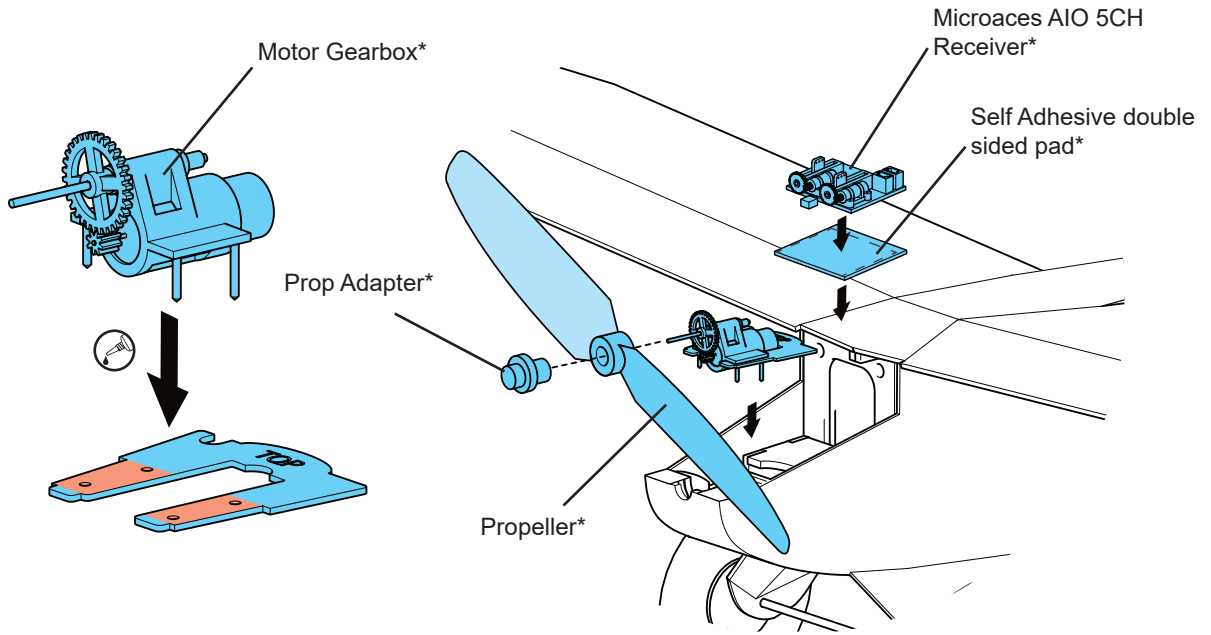

✳ Parts included in Scrappee flight pack. Not included in kit only option

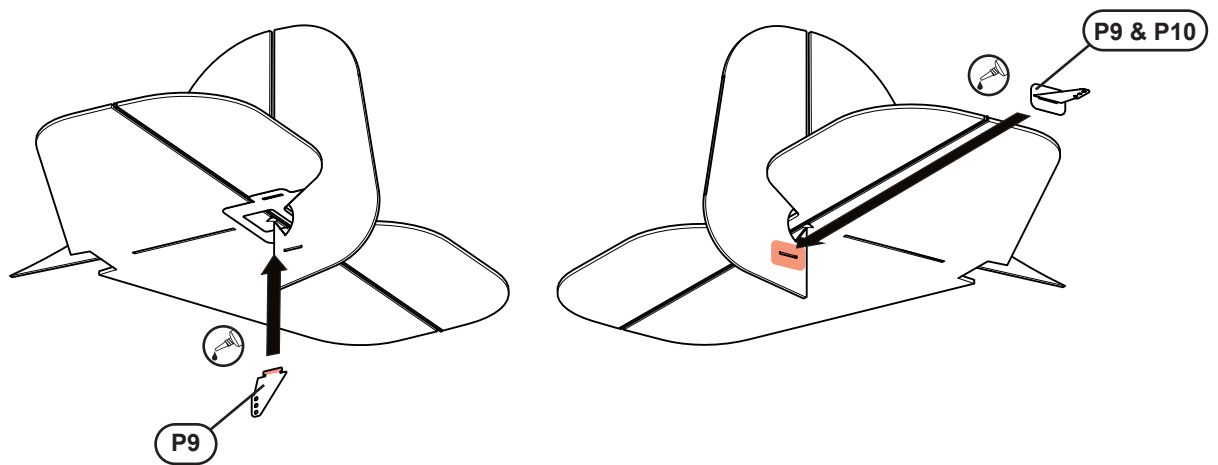
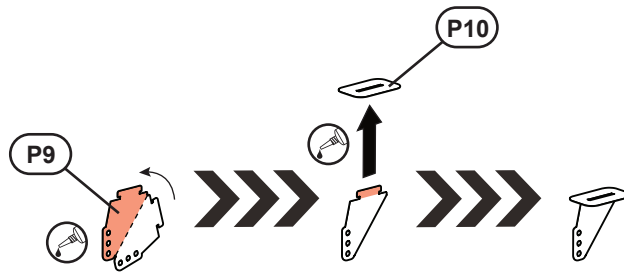

STAGE 9 CONTROLS



Insert individual control wire from the rear and attach to appropriate control horn. Set control surface to neutral then, using slim or needle nose pliers, bend the end of the control wire at the point it will need to attach to the servo arm. Un-hook the control wire from the control horn, pull out of the fuselage and complete the hook bend for the servo arm. Trim hook to 4mm in length.

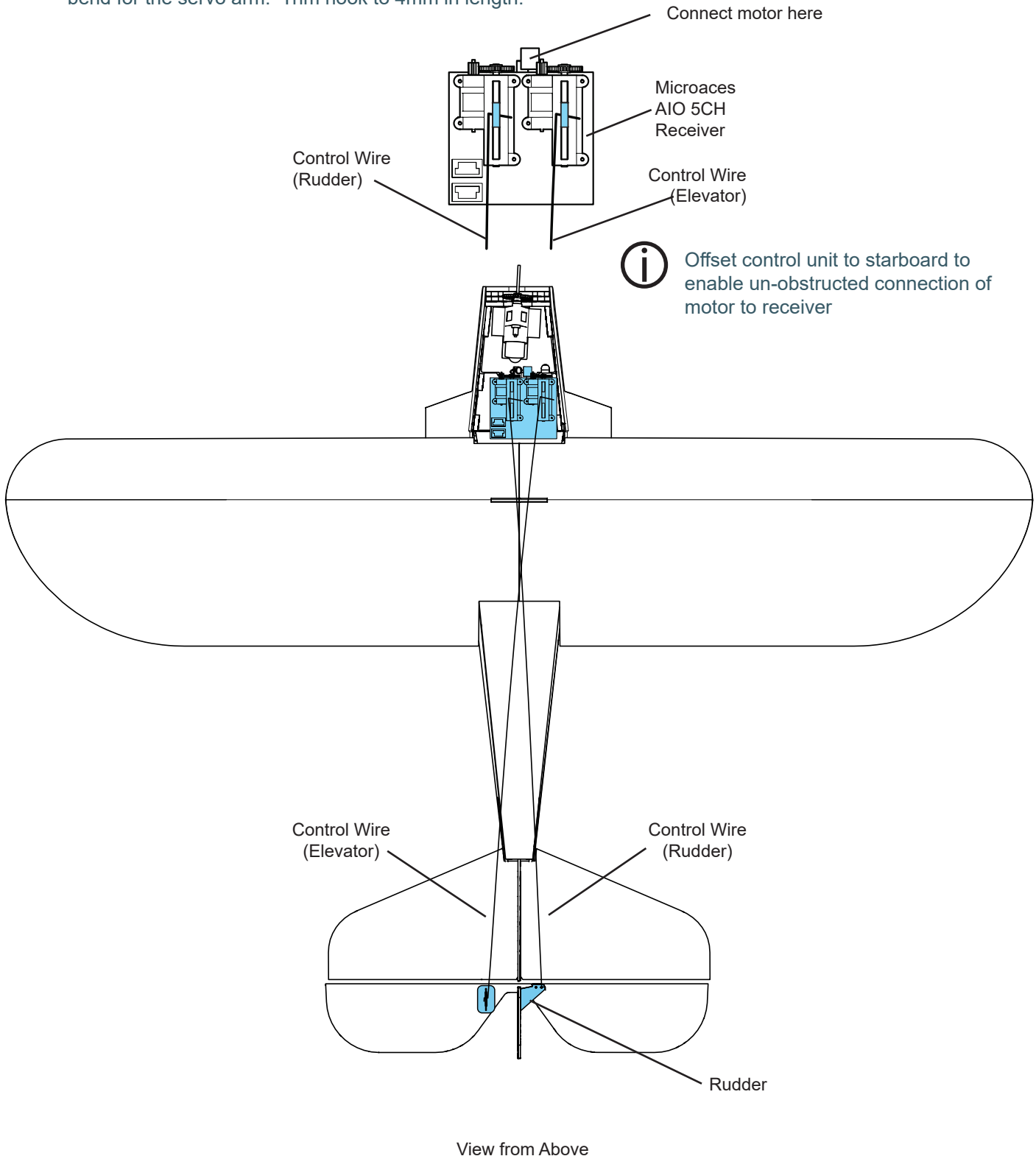

The Control Horns for the rudder and elevator are very flexible. Install the control wires for each and use tweezers to bend the horns to insert the 'Z' bend into the hole.

Use the outer hole of the control horns for more gentle control of your aircraft!

STAGE 10 FINISHING TOUCHES

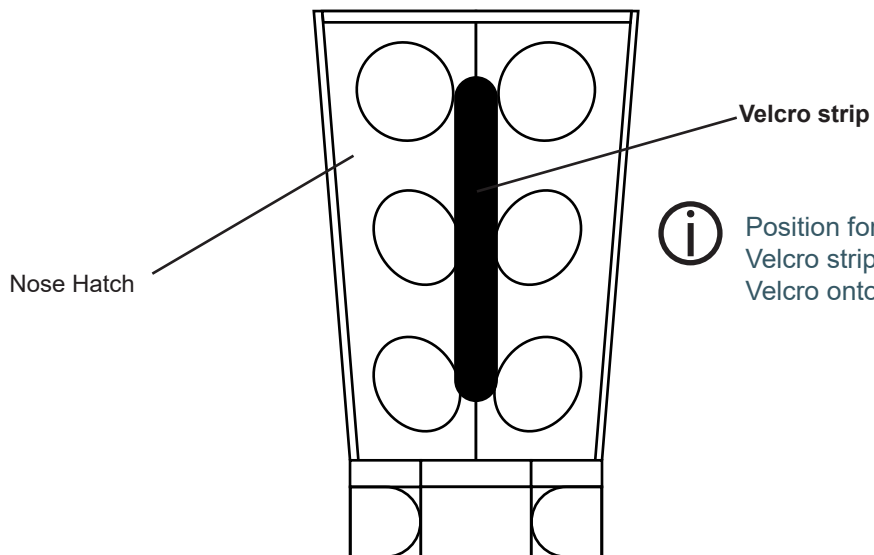
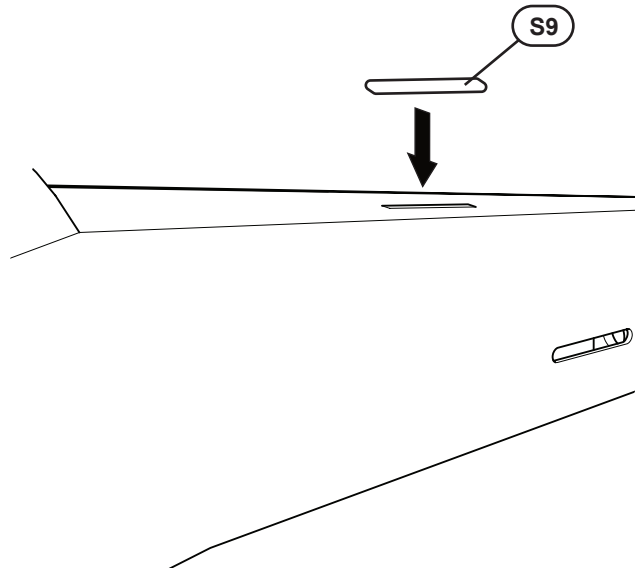

i Position for Battery placement on Velcro strip. Place corresponding Velcro onto battery.

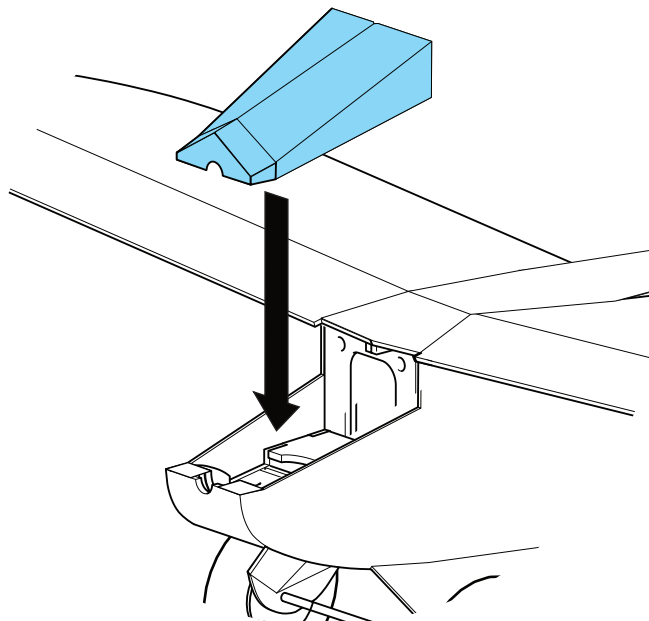

STAGE 10 FINISHING TOUCHES

Centre of Gravity (CoG)

With all the electronics installed including the battery, the CoG should be around the apex of the top wing as shown on the diagram below.

Balance on finger tips to see if the aircraft balances at this point. Before adding any weight it is advisable to perform a glide test. Add weight accordingly to obtain a smooth glide.

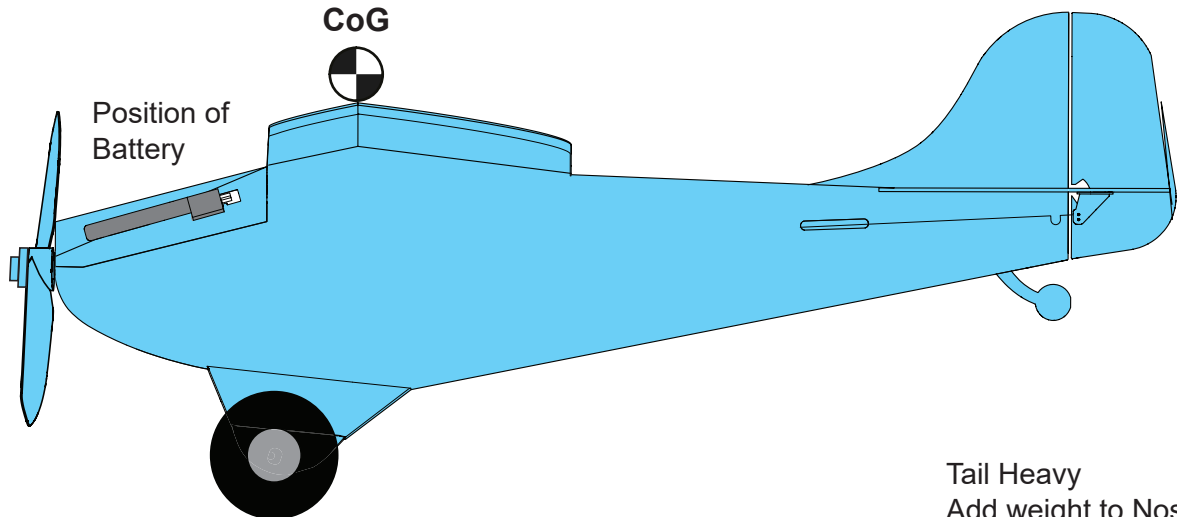

Glide Test - How to!

Find a suitable test space with a forgiving landing area, e.g. over long grass or onto soft furnishings. Ensure all control surfaces are in the neutral position. Gently toss the model straight and level. Observe the results and add balancing weight if required.

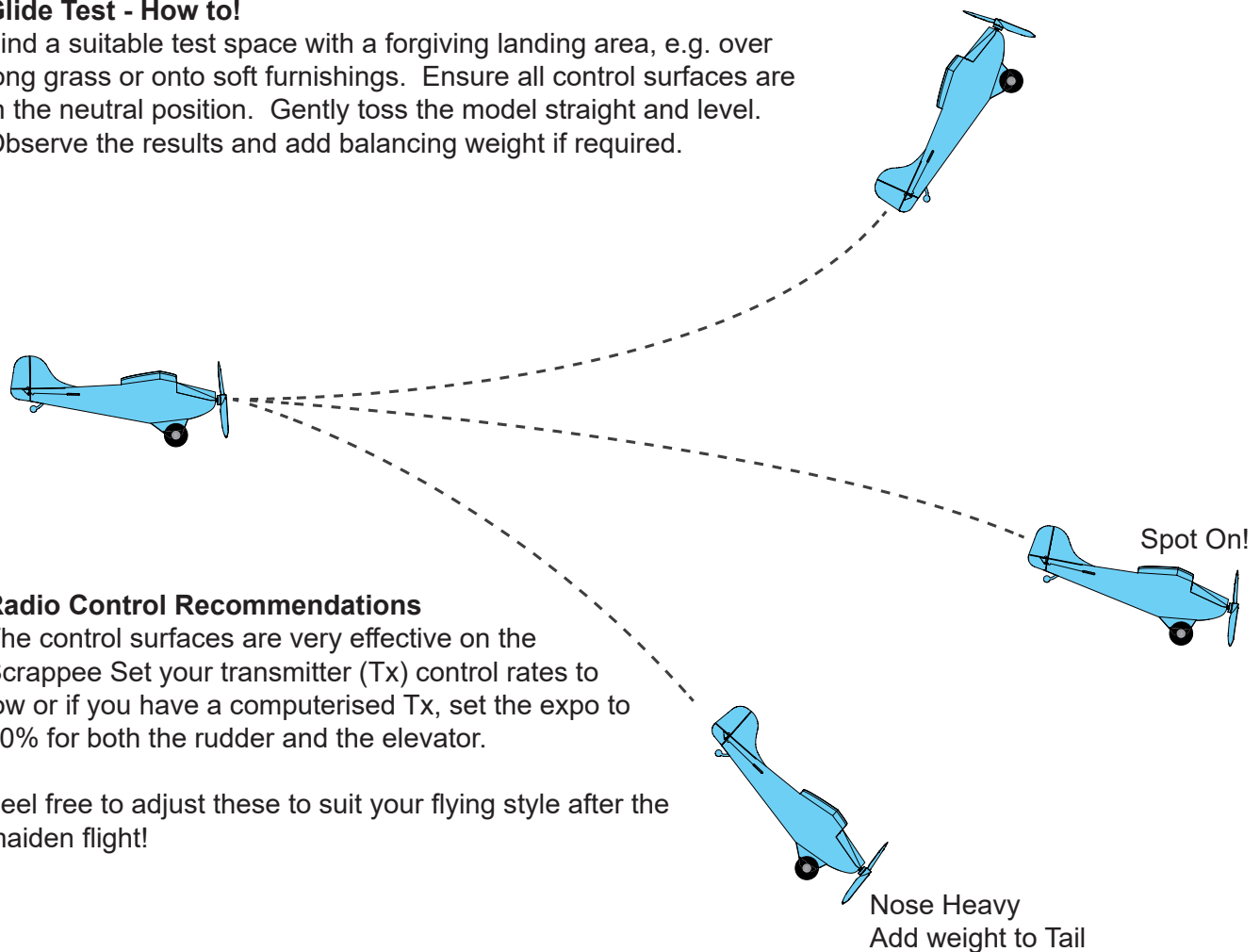

Radio Control Recommendations

The control surfaces are very effective on the Scrappee Set your transmitter (Tx) control rates to low or if you have a computerised Tx, set the expo to 50% for both the rudder and the elevator.

Feel free to adjust these to suit your flying style after the maiden flight!

Happy Flying!