

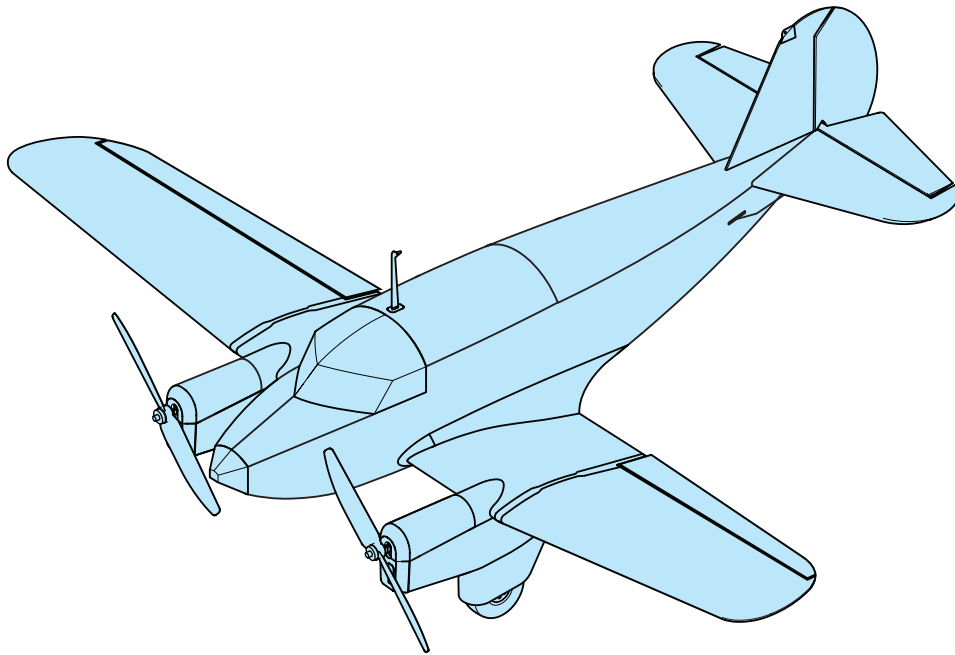

ASSEMBLY GUIDE



PERCEE

Inspired by the Percival Q6 Petrel

Version 1



Introduction

Thank you for purchasing this Microaces Aero Kit. Designed using innovative ideas, advanced materials and detailed aircraft illustrations, this model aircraft will bring you hours of building enjoyment and many more exciting flying hours too. Please take your time to familiarise yourself with these instructions as the aircraft assembles in a very unique way, following a sequence of steps that should be adhered too to ensure a satisfactory and flyable model.

Safety

It is extremely important to us that you and those around you remain safe while building and flying Microaces kits. Please take note of the following notices of safety. Microaces Aero kits contain parts and packaging **unsuitable** for handling by small children. Please ensure that children under the age of 6 years are prevented from handling the component parts or packaging of this kit. Although the resulting model is lightweight, we DON'T recommend that you fly it near or over others where there is a danger of striking someone. We DO recommend that the maiden flight is performed over long grass in calm weather away from others.











Assembly

Read all the instructions carefully before starting assembly.
It is important to use the recommended glues or an equivalent with similar properties. Foam parts must be glued with a foam safe cement or permanent damage can result to components. Ensure your knife has a fresh or sharp blade installed to ensure a clean cut.

Warranty

Microaces warrants this kit is supplied with all components present and that those components are free from cosmetic or structural damage to an extent that would impair the assembly of the kit, alter the aesthetics of the built model and/or the flight performance of the resulting model. If any parts are missing or damaged please contact us via email at: support@microaces.com

Key

- | | | | |
|---|-----------------------------------|--|-----------------------|
|  | Note (Information) |  | Attention |
|  | Part Number |  | Do Not Glue |
|  | Contact Adhesive (Foam Safe) |  | Score before assembly |
|  | Aliphatic Resin (or Foam Safe CA) |  | Cut |
|  | Paint |  | Sanding Required |
|  | Area of adhesion for glue | | |

KIT PARTS

Sheet Parts	2 x 2mm Laser cut foam airframe 2 x 1mm printed & laser cut foam wings 3 x Tyvek© printed and laser cut fuselage 1 x laser cut polyprop. parts 1 x polyester stickers 1 x 0.8mm laser cut plywood
Loose Parts	2 x pre-assembled wheels 1 x 2mm x 50mm dia. carbon fibre tube (for axles) 4 x piano wire control rods 2 x 1mm dia. carbon fibre tube (control rods) 1 x 3.0mm x 0.4mm x 165mm carbon fibre strip (elevator reinforcement) 4 x 4mm x 1mm neodymium magnets 8 x 3mm x 1mm neodymium magnets

RECOMMENDED TOOLS/GLUES

Knife or Scalpel with fresh blade
Steel Rule or straight edge
Sanding Stick or sand paper (180 grit recommended)
Tweezers
Needle nose pliers & wire cutters
UHU por foam safe adhesive (For foam & plastic)
Aliphatic Resin or Foam safe cyano glue (for rigging & re-inforcement)

RECOMMENDED ELECTRONICS

The Microaces Percee is designed around a Micro SR3X 5 channel 2.4GHz receiver, with twin ESC for brushed motor operation AND 3 Axis Stabilization.

Recommended servos are 2 (for 3 channel operation) or 4 (for 4 channel operation) 1.7g low voltage micro digital servos.

Recommended motors are 2 x Microaces Micro Motor/Gearbox LONG prop shaft

An entire flight pack for the Percee is available at www.microaces.com

Recommended battery: 180 - 400 mAh Lipo with 'UM' style connector.

Example: E-Flite EFLB3001S25 300mAh Lipo

IMPORTANT INFORMATION ON GLUING TYVEK

Tyvek may distort when exposed to glues that use a petroleum or aliphatic solvents.

When assembling Tyvek parts & panels using UHU por or similar petroleum or aliphatic based contact adhesives, allow the glue to **thoroughly dry** before assembling. When the glue is dry, any effect on Tyvek is minimised.

Where possible, apply the glue to the material the Tyvek is to be stuck to and allow the glue to dry on that surface.

When glue has to be applied directly to Tyvek, use sparingly and apply evenly. Any material distortion should return to shape once the solvent has evaporated.

If using other glues, please test on a scrap piece of material before proceeding.

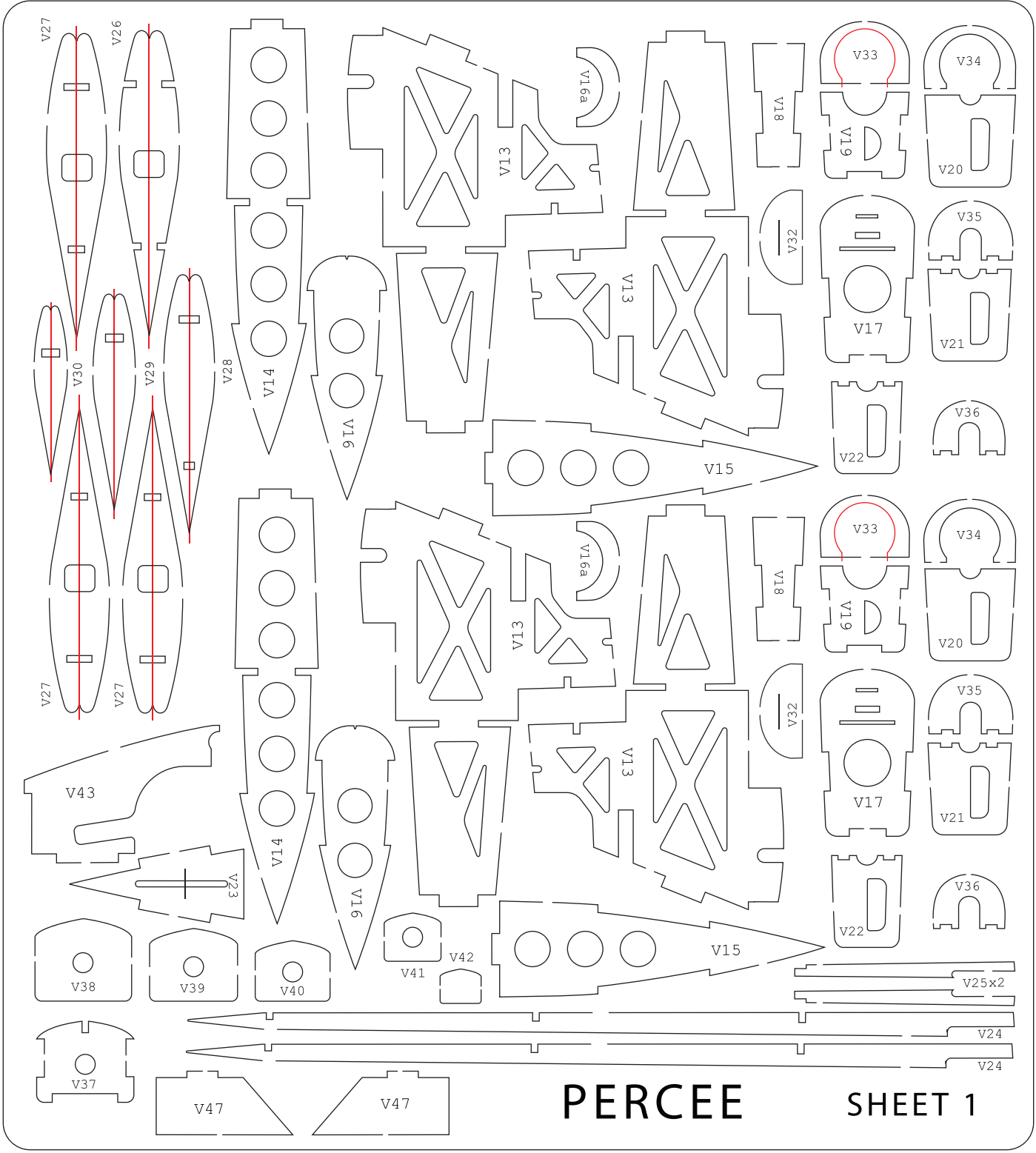

PERCEE

SHEET 1

PERCEE

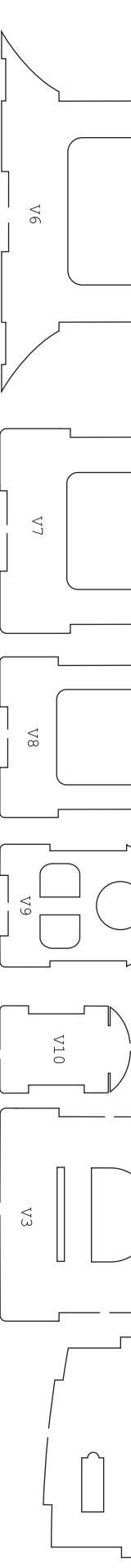
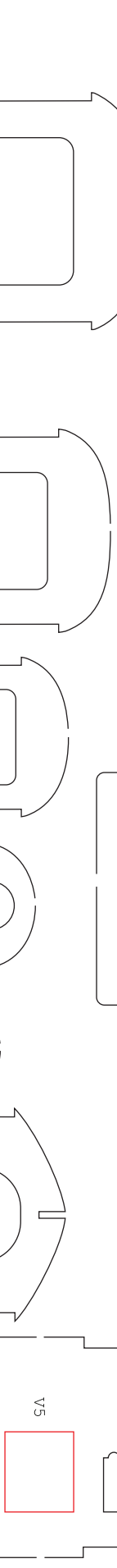
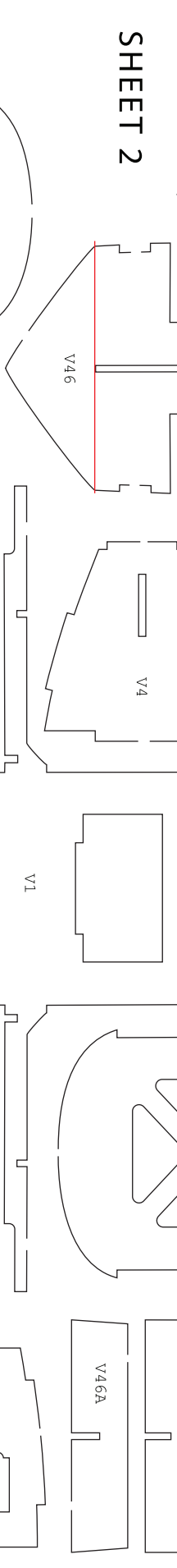
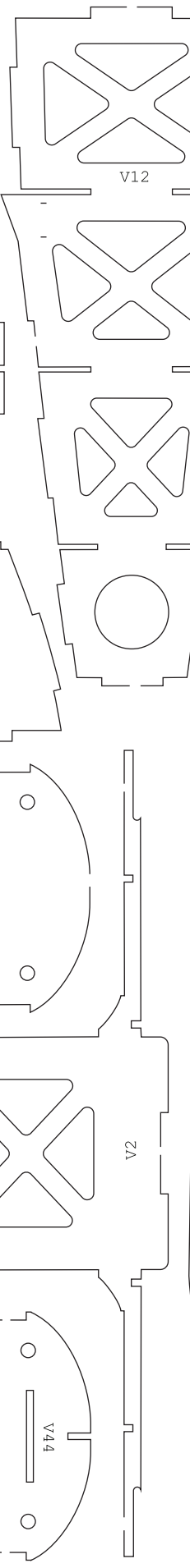
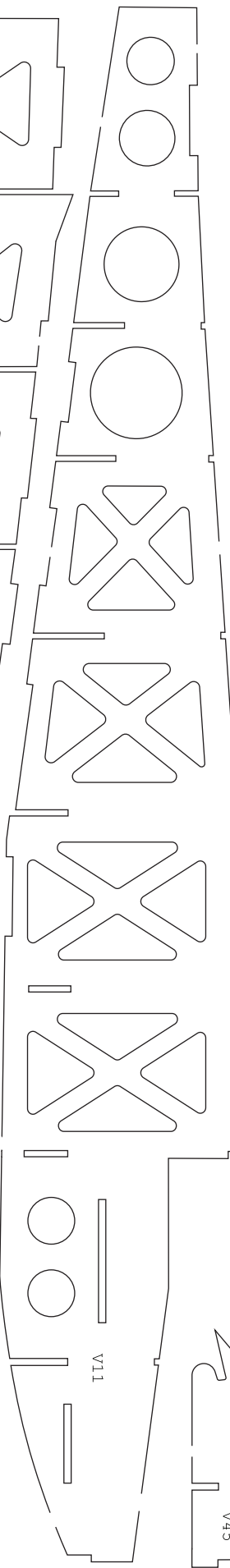
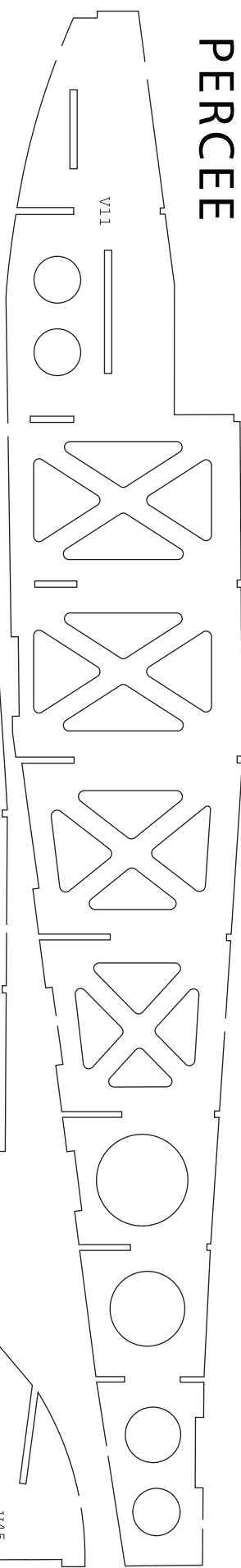

SHEET 2

TYVEK PARTS

IMPORTANT INFORMATION ON GLUING TYVEK

Tyvek may distort when exposed to glues that use a petroleum or aliphatic solvents.

When assembling Tyvek parts & panels using UHU por or similar petroleum or aliphatic based contact adhesives, allow the glue to thoroughly dry before attaching. When the glue is dry, any effect on Tyvek minimised.

Where possible, apply the glue to the material the Tyvek is to be stuck to and allow the glue to dry on that surface.

When glue has to be applied directly to Tyvek, use sparingly and apply evenly. Any material distortion should return to shape once the solvent has evaporated.

If using other glues, please test on a scrap piece of material before proceeding.

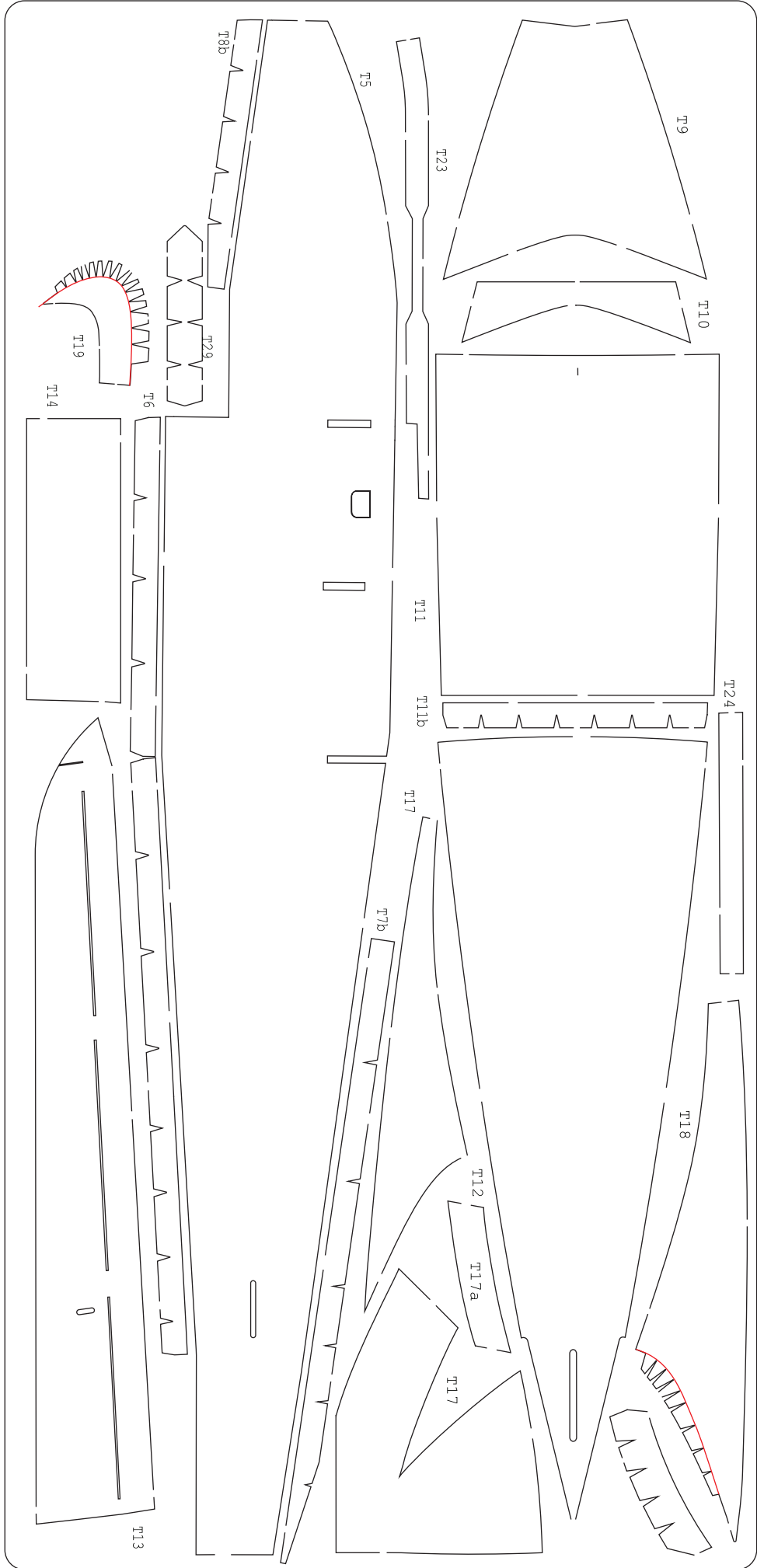

TYVEK PARTS

IMPORTANT INFORMATION ON GLUING TYVEK

Tyvek may distort when exposed to glues that use a petroleum or aliphatic solvents.

When assembling Tyvek parts & panels using UHU por or similar petroleum or aliphatic based contact adhesives, allow the glue to thoroughly dry before attaching. When the glue is dry, any effect on Tyvek minimised.

Where possible, apply the glue to the material the Tyvek is to be stuck to and allow the glue to dry on that surface.

When glue has to be applied directly to Tyvek, use sparingly and apply evenly. Any material distortion should return to shape once the solvent has evaporated.

If using other glues, please test on a scrap piece of material before proceeding.

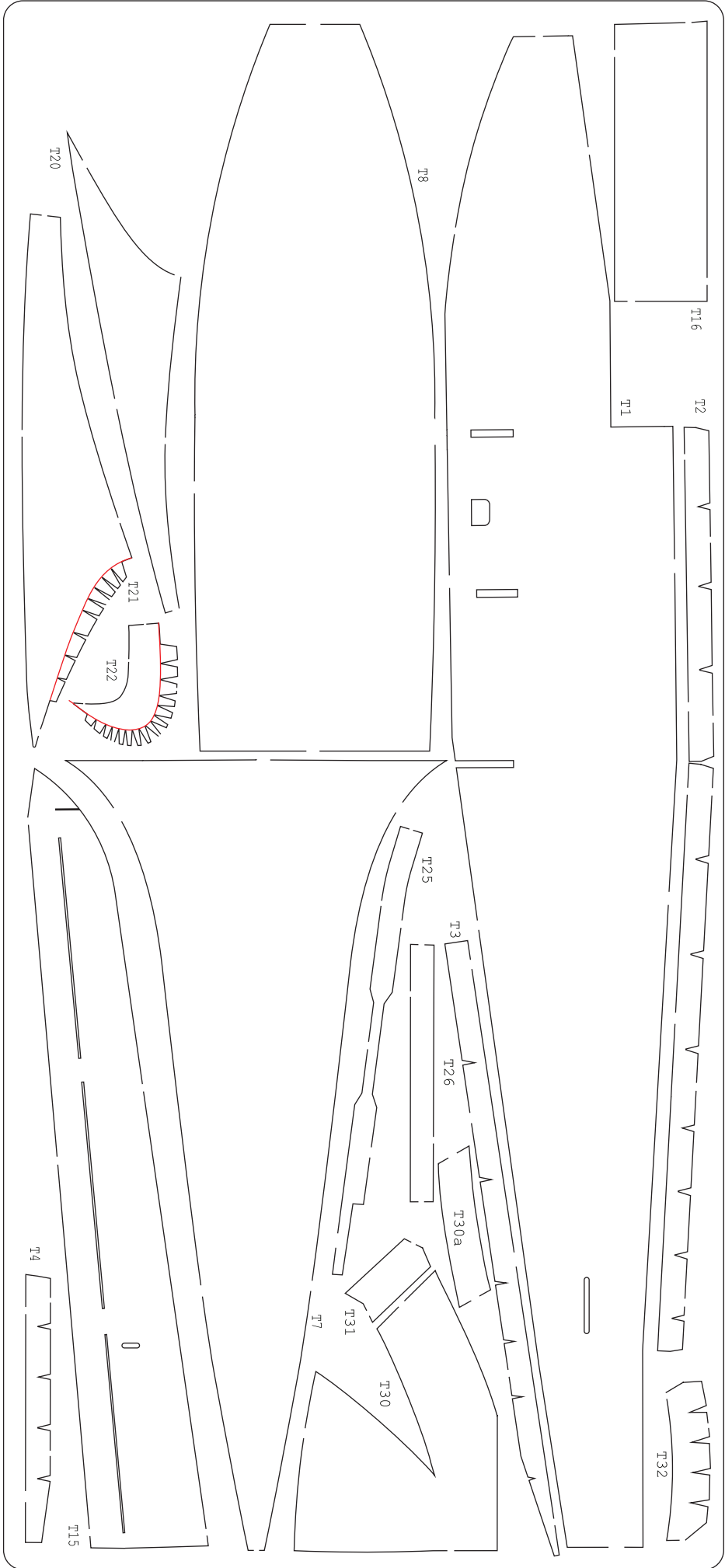

IMPORTANT INFORMATION ON GLUING TYVEK

Tyvek may distort when exposed to glues that use a petroleum or aliphatic solvents.

When assembling Tyvek parts & panels using UHU por or similar petroleum or aliphatic based contact adhesives, allow the glue to thoroughly dry before attaching. When the glue is dry, any effect on Tyvek minimised.

Where possible, apply the glue to the material the Tyvek is to be stuck to and allow the glue to dry on that surface.

When glue has to be applied directly to Tyvek, use sparingly and apply evenly. Any material distortion should return to shape once the solvent has evaporated.

If using other glues, please test on a scrap piece of material before proceeding.

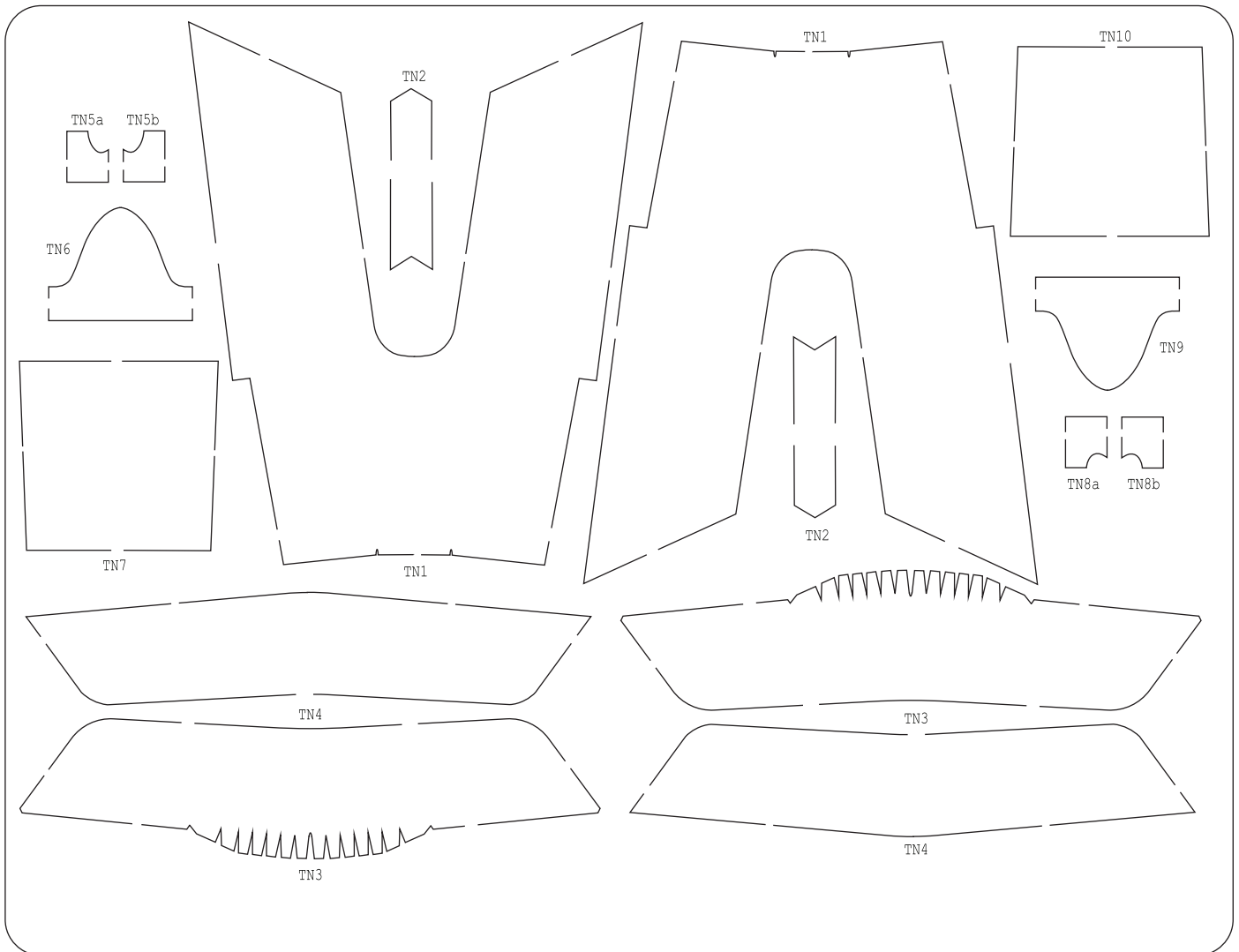

PLASTIC PARTS

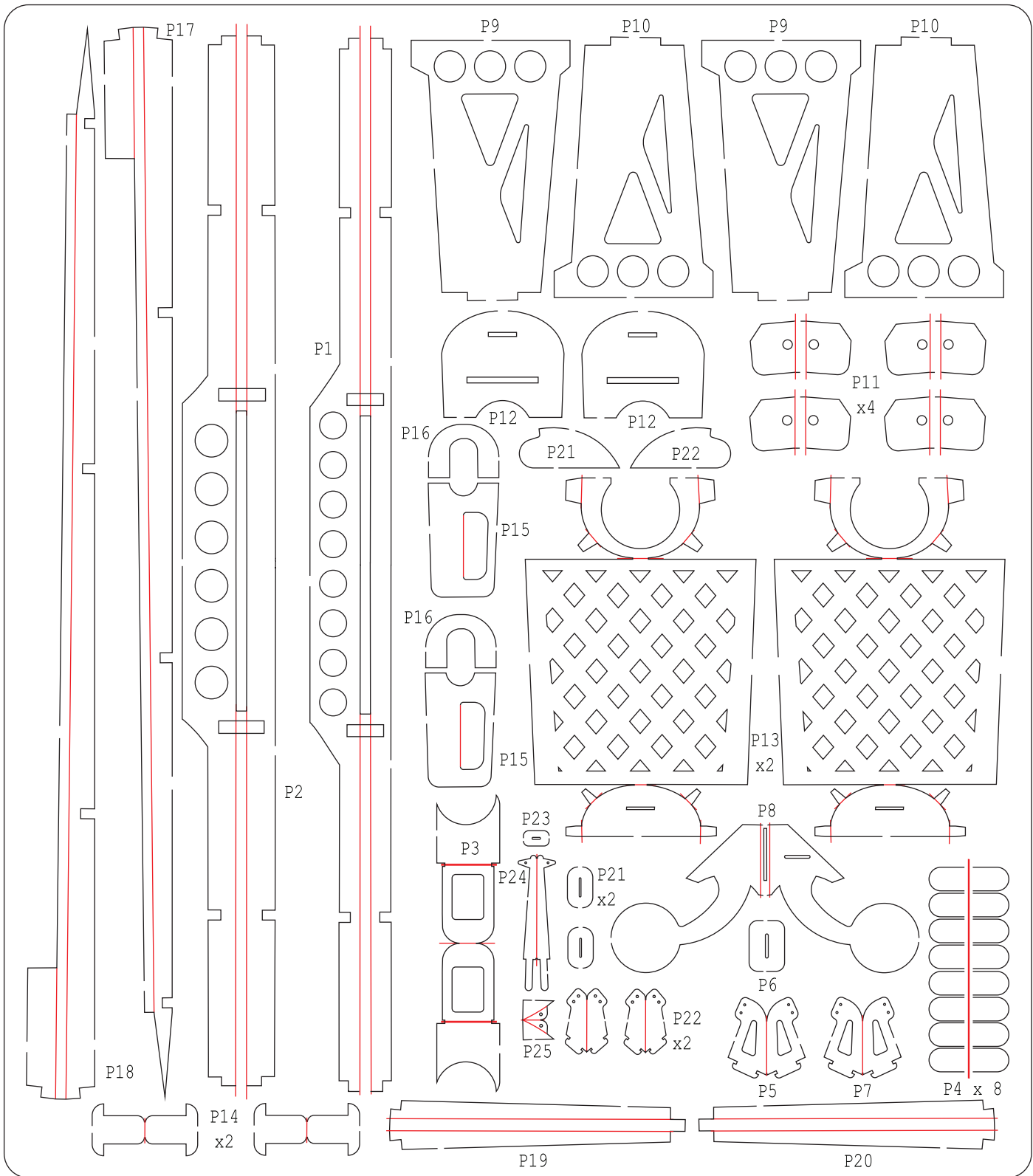

1mm PARTS

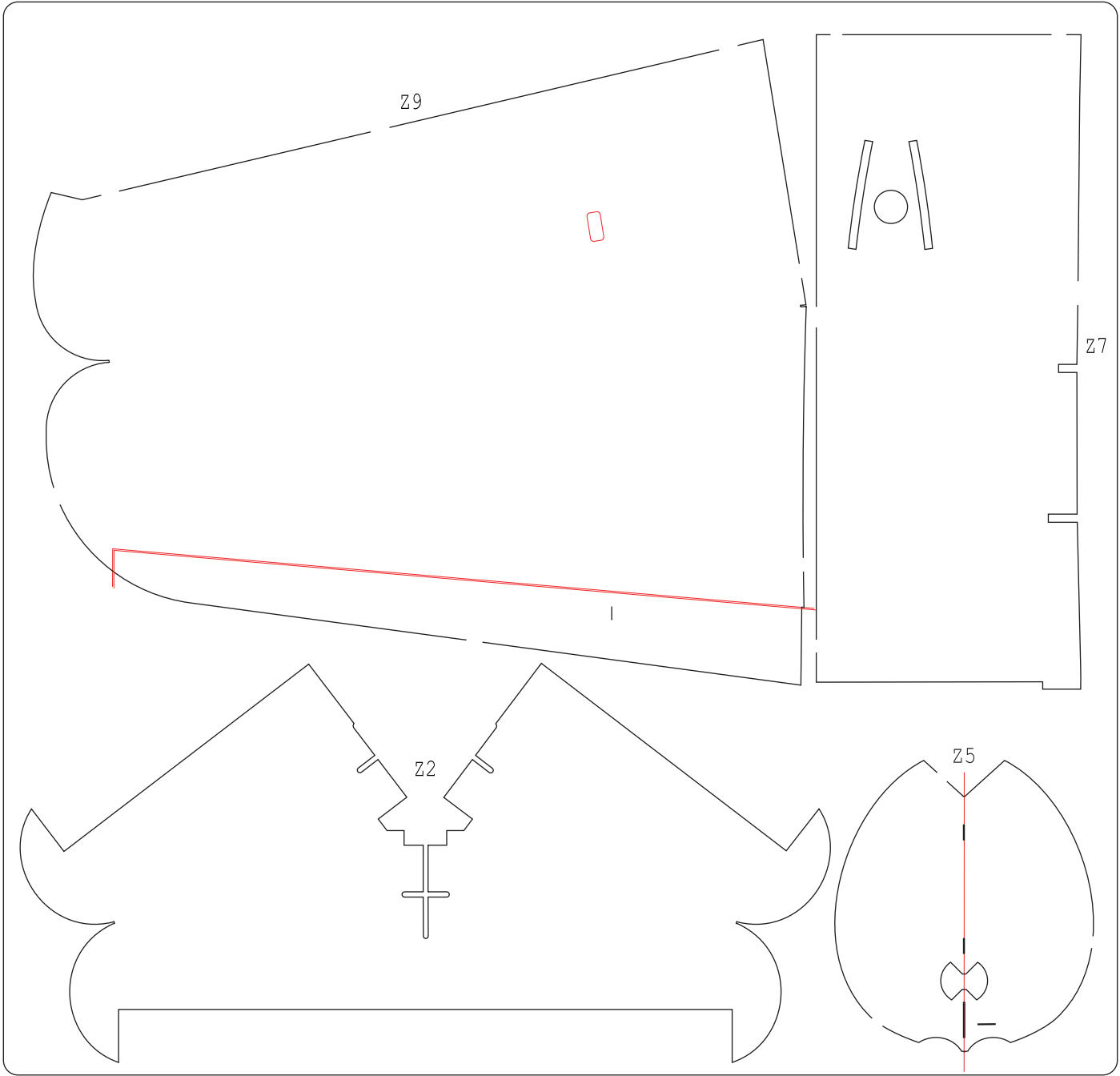

1mm PARTS

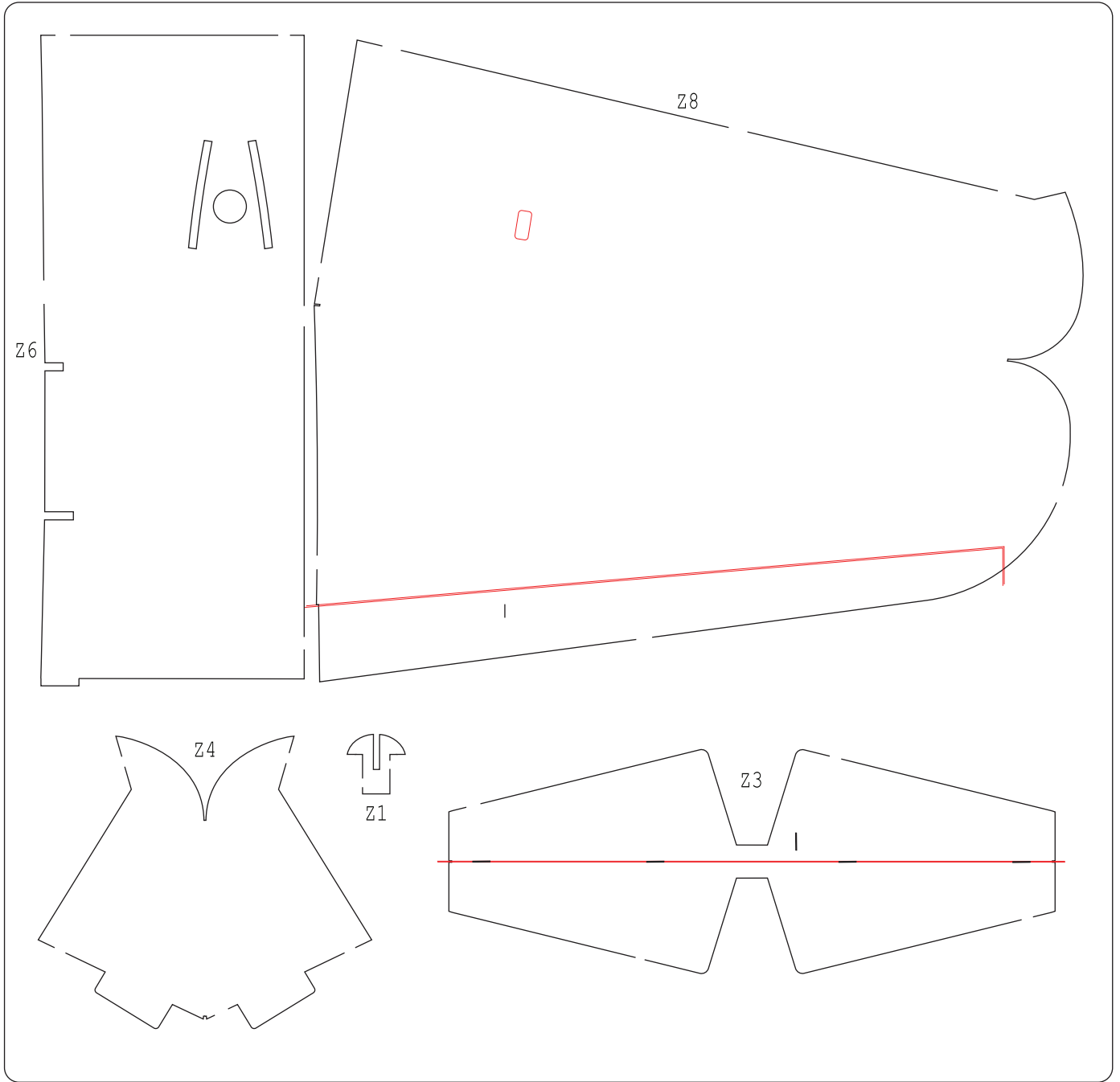

0.8mm PLYWOOD

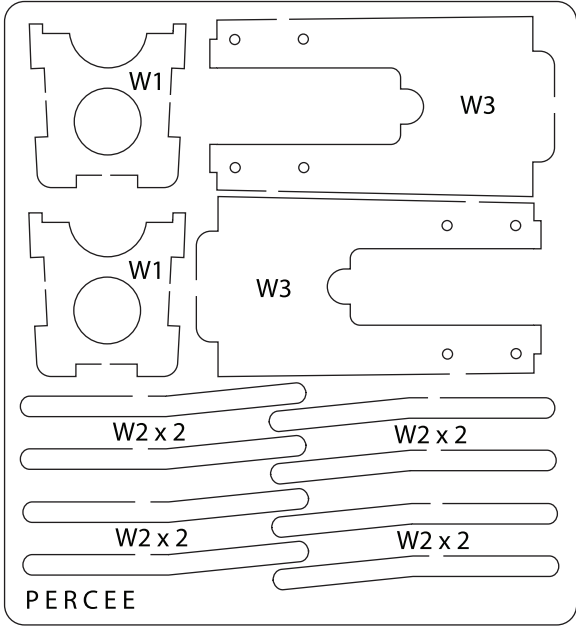

STICKERS

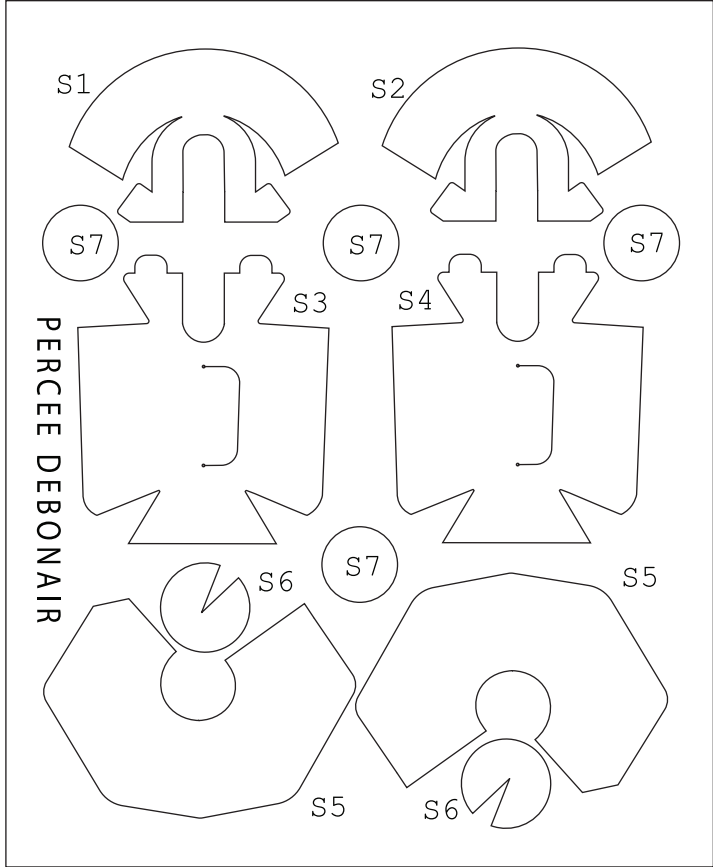

SCORING & BEVELING GUIDE #1

Method for scoring 1mm Foam

Using a straight edge as a guide, score the Foam with the **reverse** side of a craft knife or a ball point pen.

If you haven't used this technique before it is essential that you practice using a scrap or spare piece of 1mm Foam prior to processing any kit components.

----- Remove aileron if installing aileron controls to kit

! Always score on the UNPRINTED side of the Depron unless otherwise directed

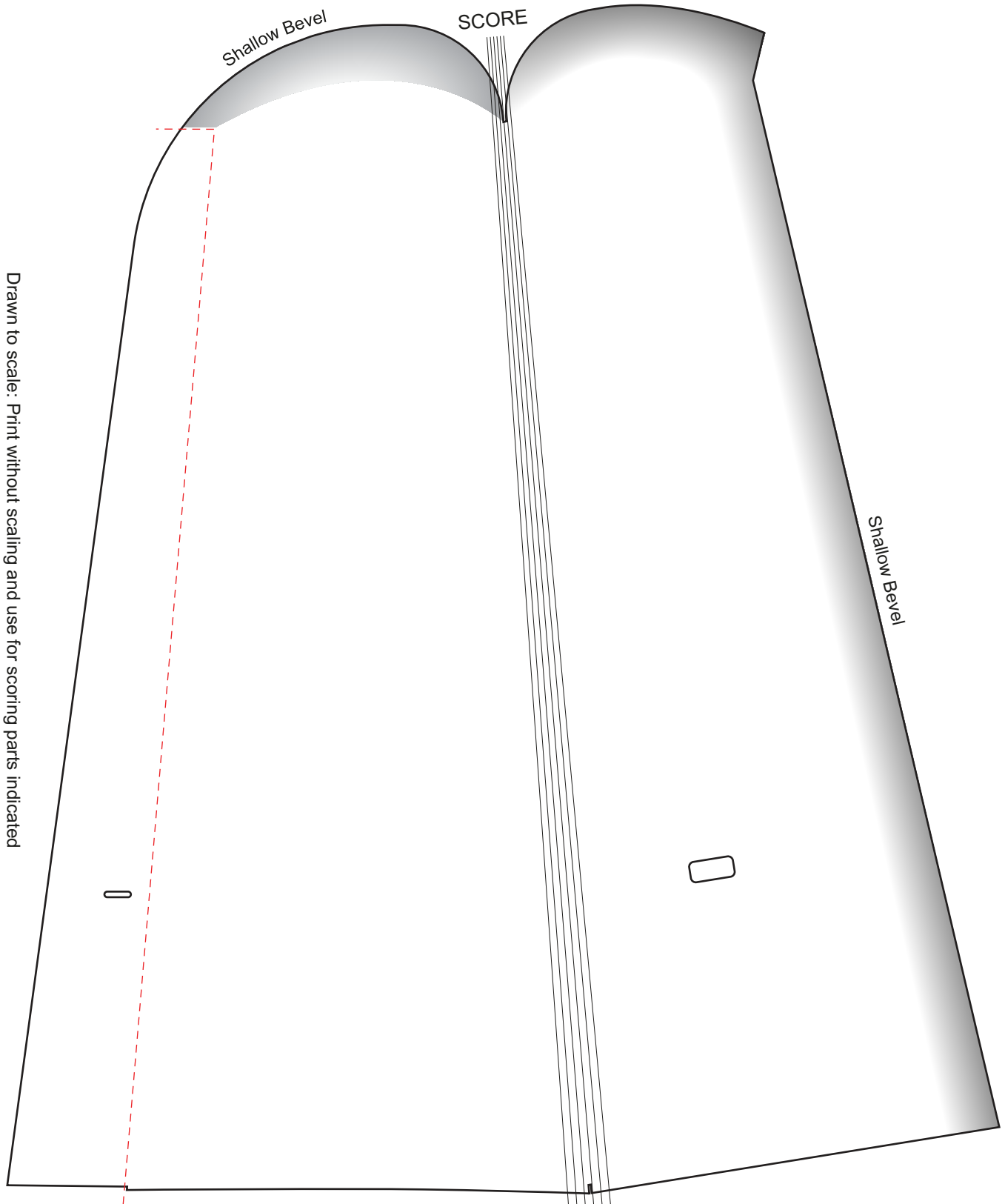

SCORING & BEVELING GUIDE #2

Method for scoring 1mm Foam

Using a straight edge as a guide, score the Foam with the **reverse** side of a craft knife or a ball point pen.

If you haven't used this technique before it is essential that you practice using a scrap or spare piece of 1mm Foam prior to processing any kit components.

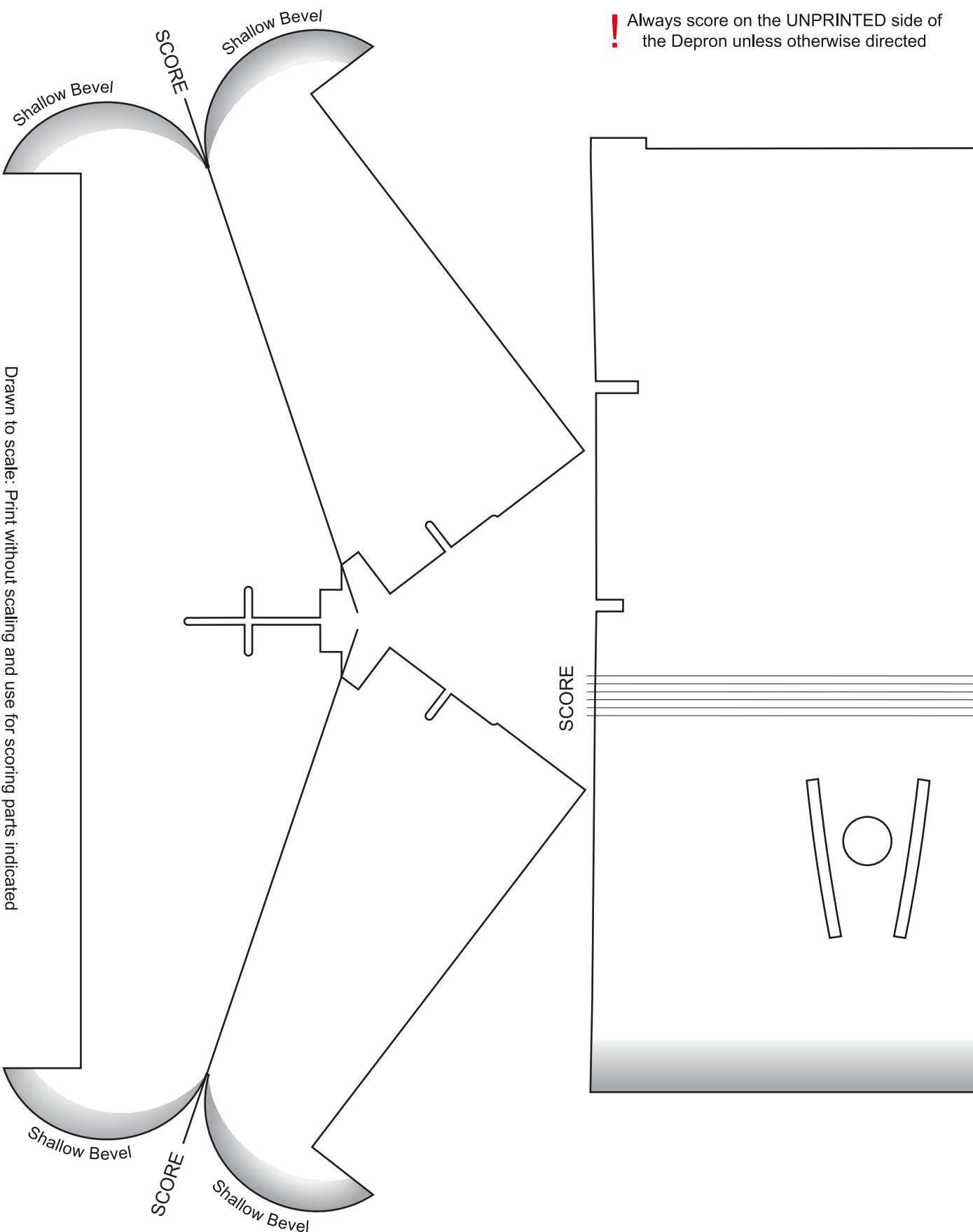

SCORING & BEVELING GUIDE #3

Method for scoring 1mm Foam

Using a straight edge as a guide, score the Foam with the **reverse** side of a craft knife or a ball point pen.

If you haven't used this technique before it is essential that you practice using a scrap or spare piece of 1mm Foam prior to processing any kit components.

--- Laser scored Line

! Always score on the UNPRINTED side of the Depron unless otherwise directed

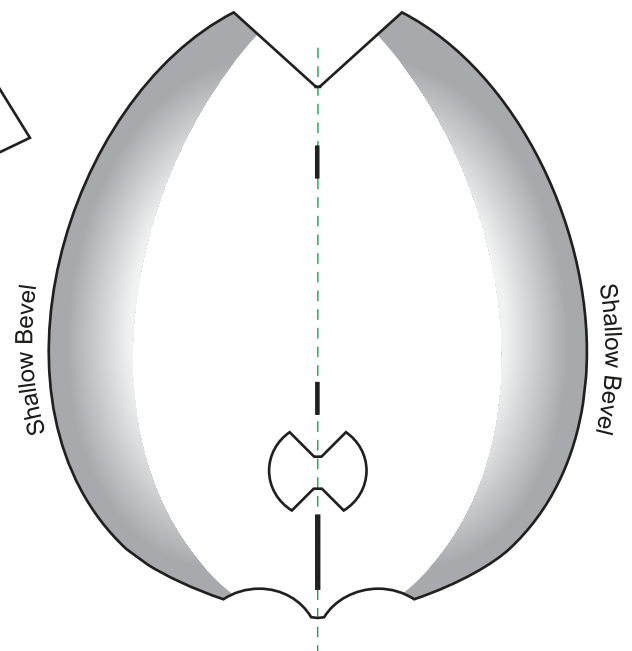
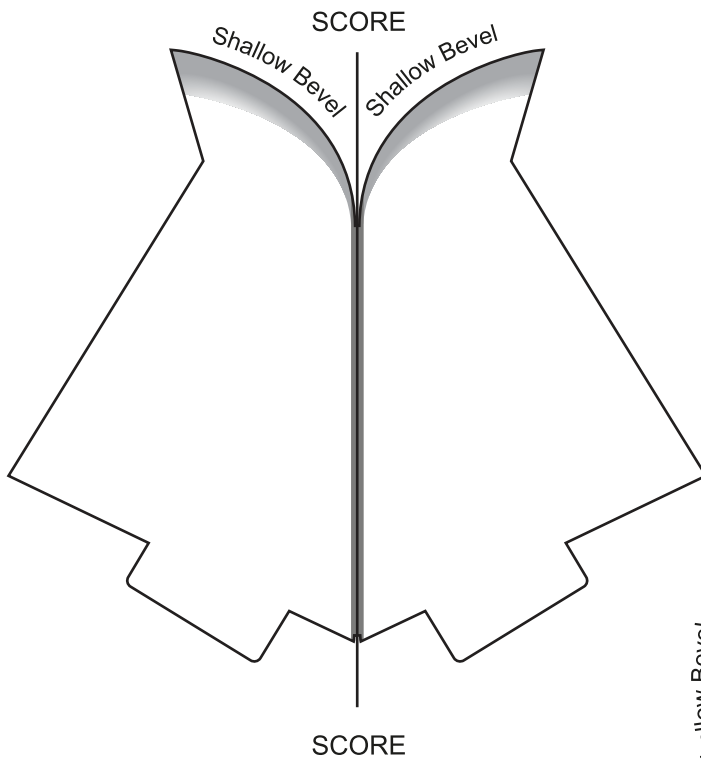
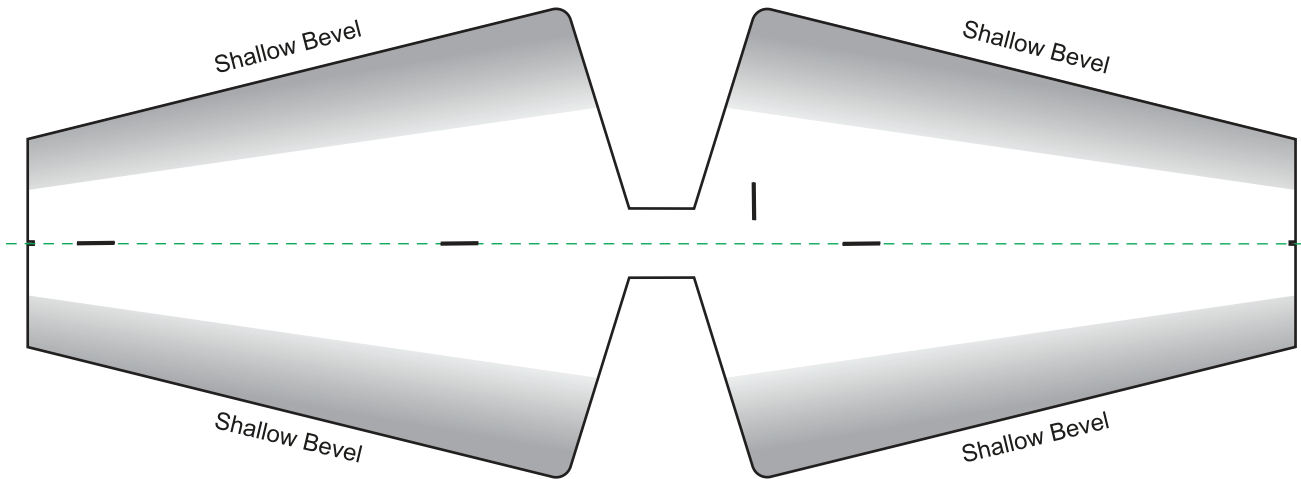

Drawn to scale. Print without scaling and use for scoring parts indicated

STAGE 1 ENGINE NACELLE



The plastic parts used in the airframe are there to increase the strength of the structure in vital areas whilst still providing some flexibility.



Apply a thin layer of adhesive to the plastic part and attach immediately to allow some wiggle time to get the parts lined up. Set aside to cure.

Use Stage 1 Engine Nacell Instructions to create both Percee engine nacelles

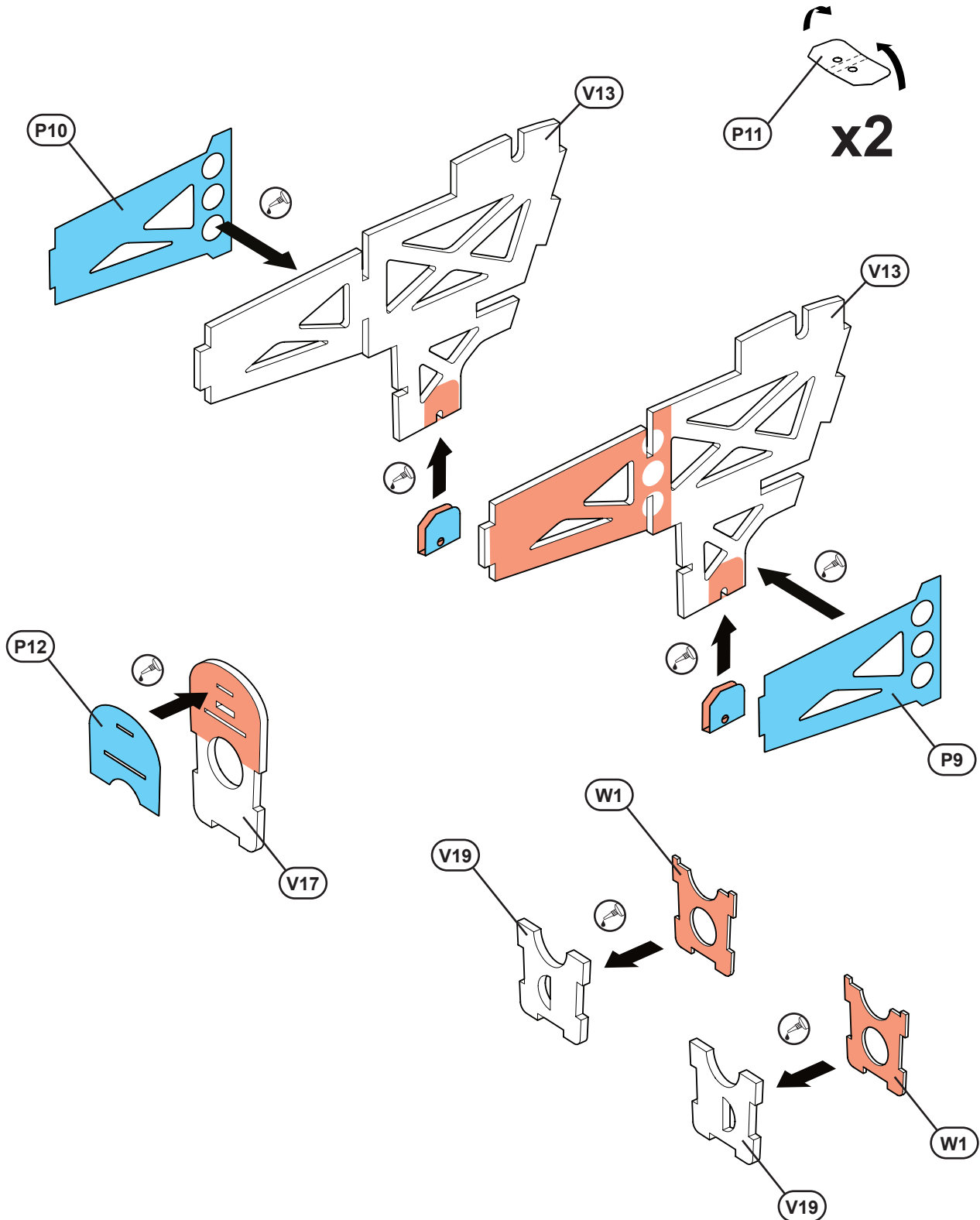

STAGE 1 ENGINE NACELLE

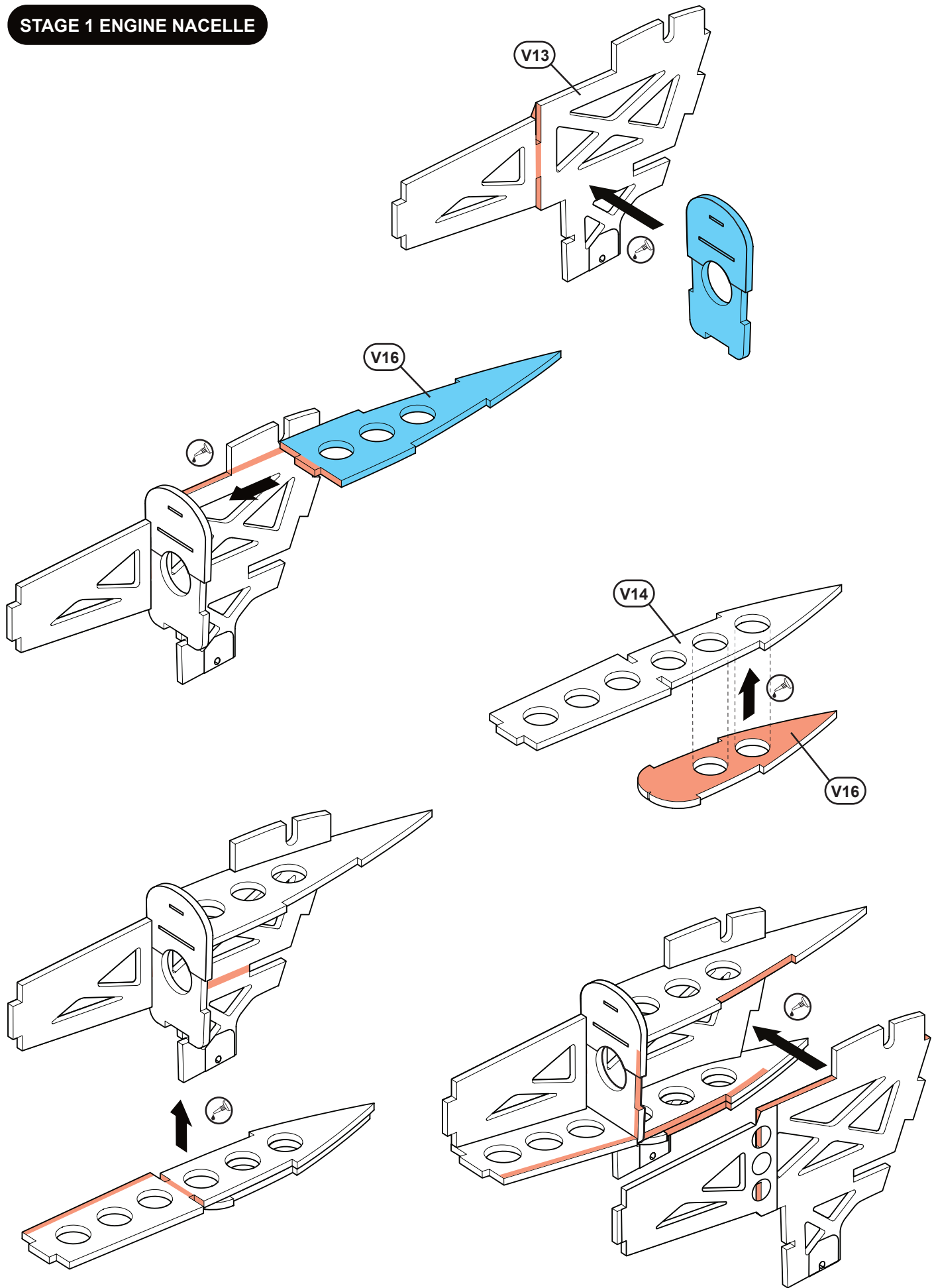

STAGE 1 ENGINE NACELLE

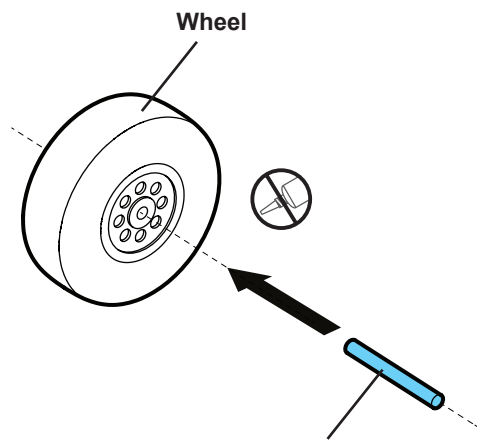
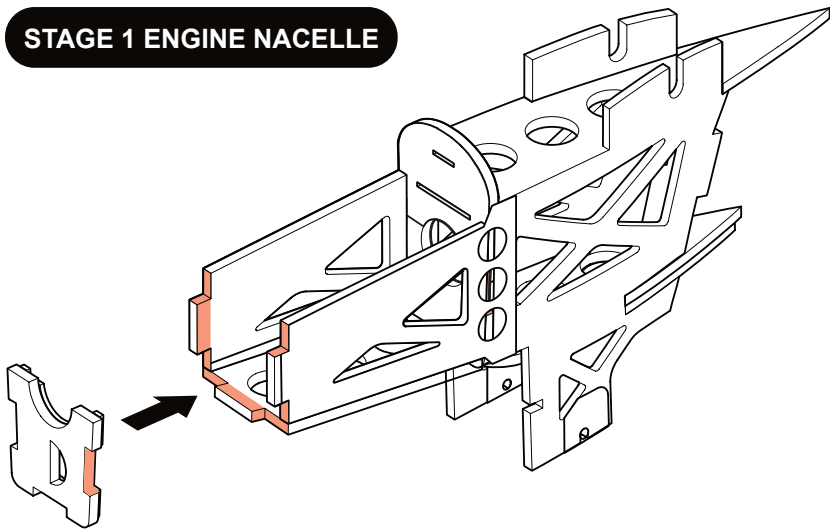

2mm dia x 18mm
Carbon Fibre axle

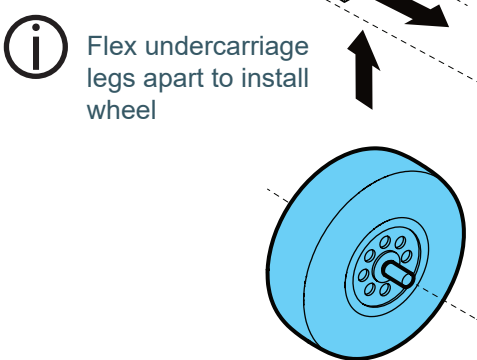
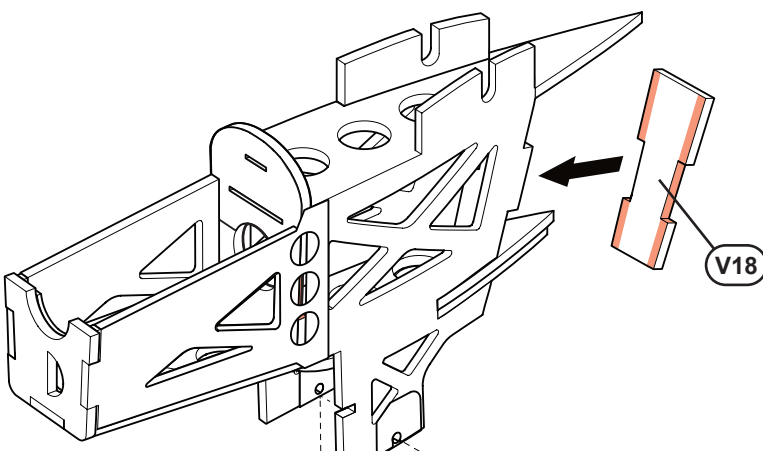

i Flex undercarriage
legs apart to install
wheel

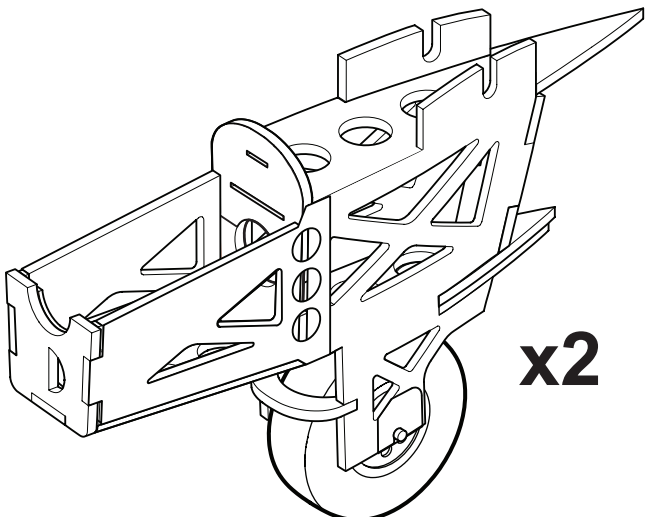
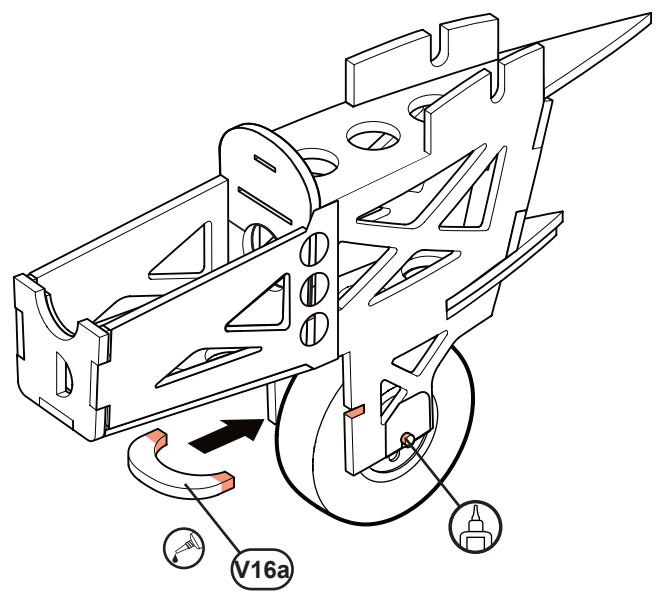

x2

STAGE 1 ENGINE NACELLE



See **Important Information on gluing Tyvek** before proceeding



Curl the Tyvek using a dowel, paint brush handle or something similar.

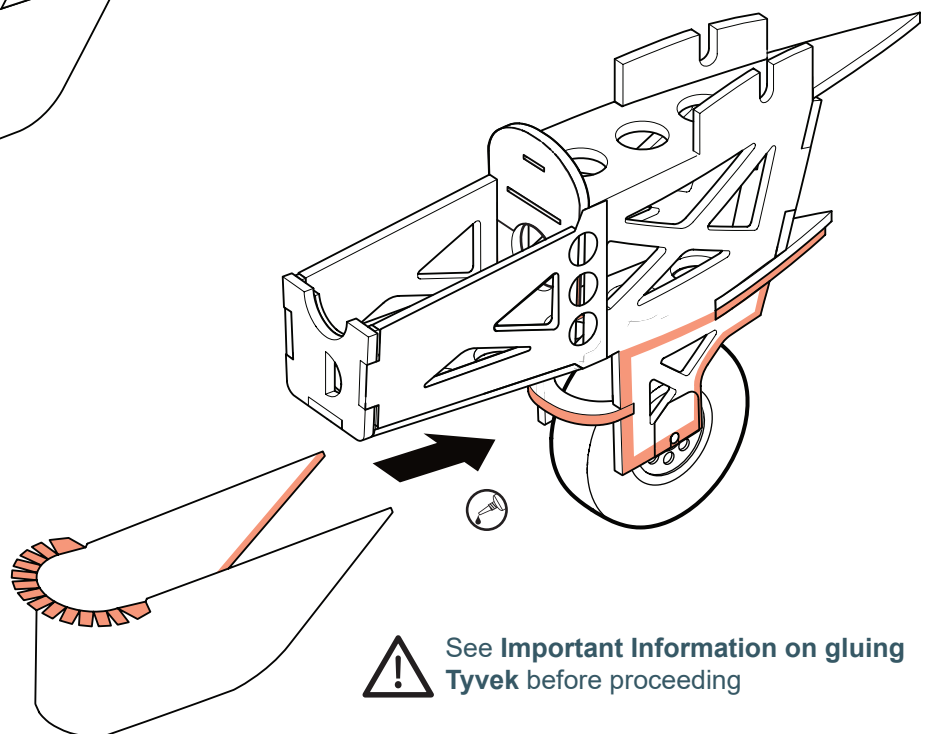
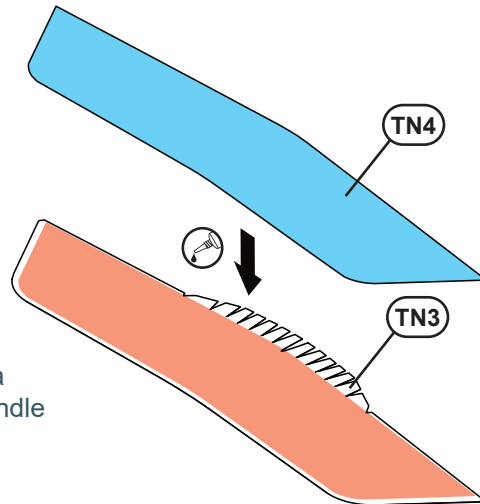
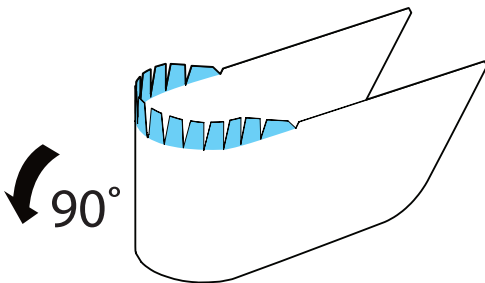
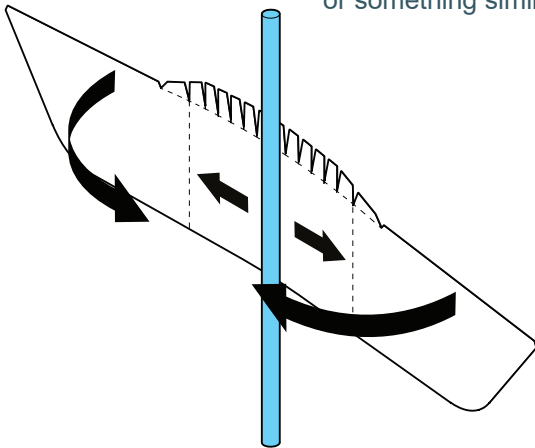

See **Important Information on gluing Tyvek** before proceeding

STAGE 1 ENGINE NACELLE

 See Important Information on gluing Tyvek before proceeding

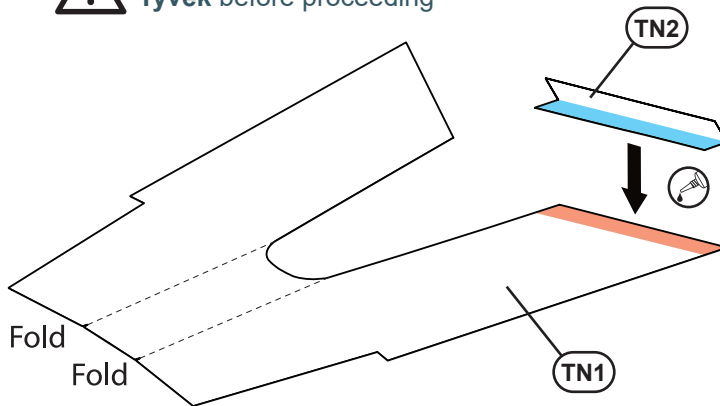
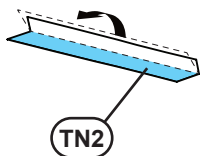
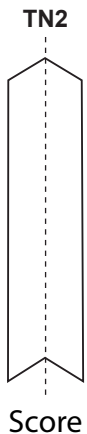

 See Important Information on gluing Tyvek before proceeding

TN5b TN8b - required on second Nacelle build

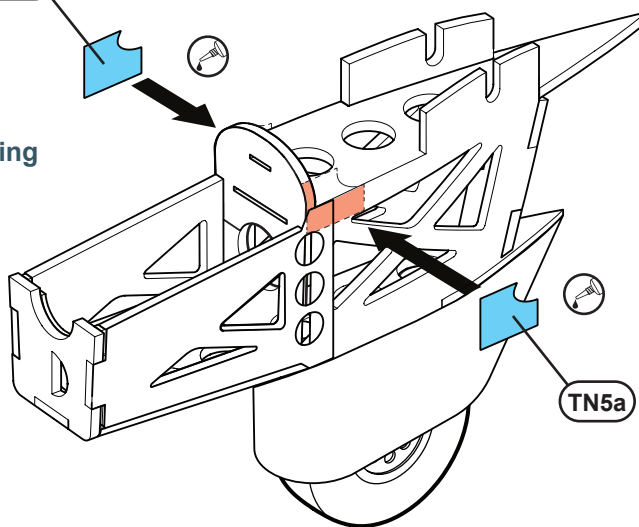

TN5a TN8a - required on second Nacelle build

 See Important Information on gluing Tyvek before proceeding

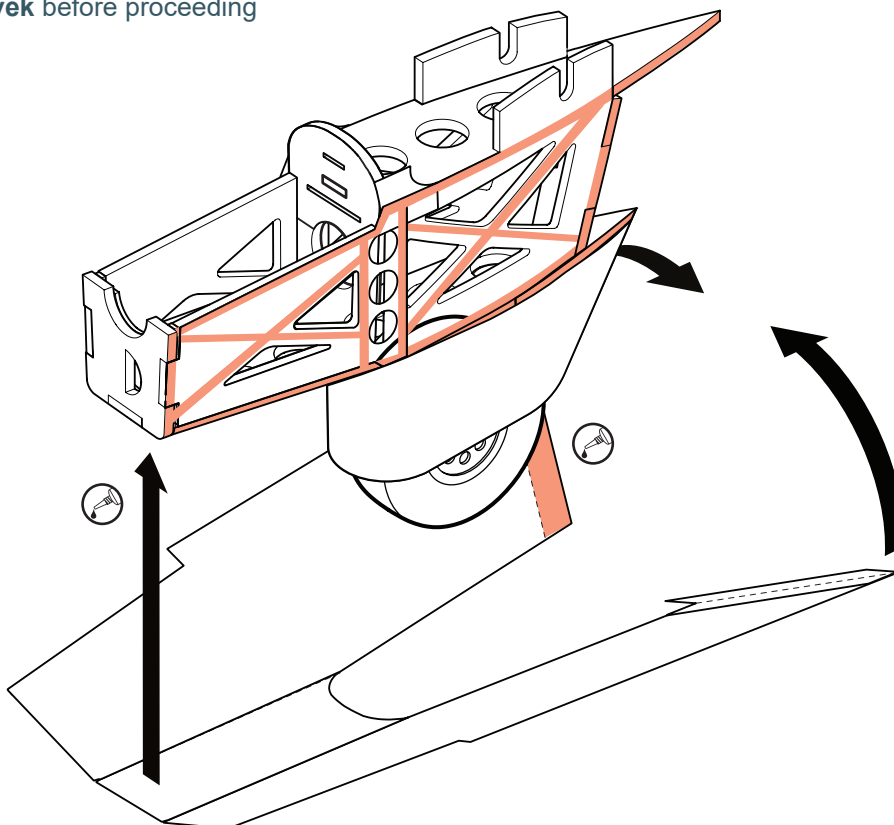

STAGE 1 ENGINE NACELLE

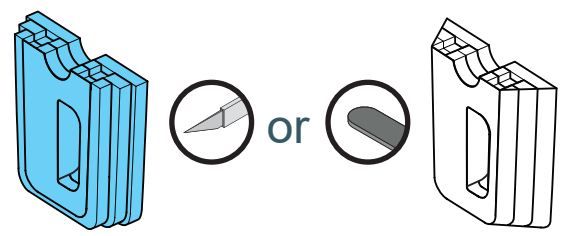
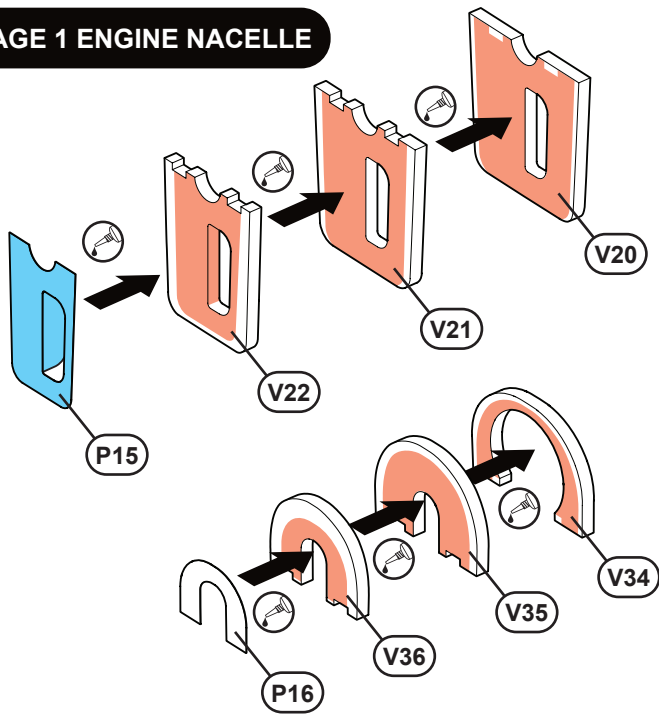

i 2mm foam can be readily carved with a fresh, sharp blade for quick results

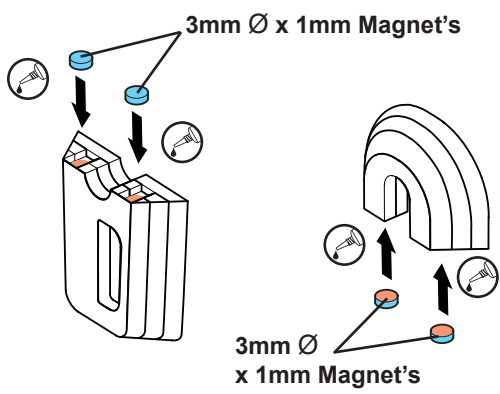
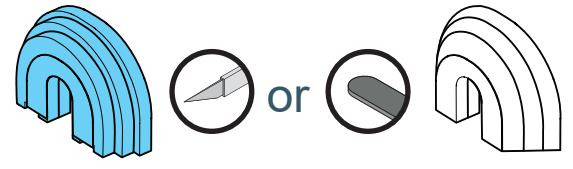

i Ensure the magnets are correctly oriented before installation. Do this by matching them to the magnets installed in the chin before installing it here.

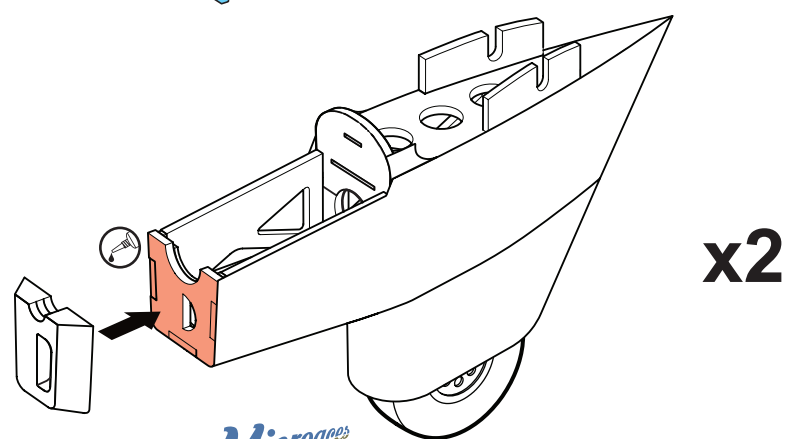
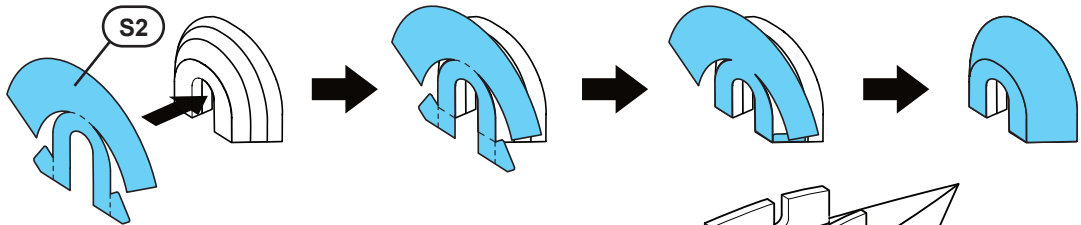
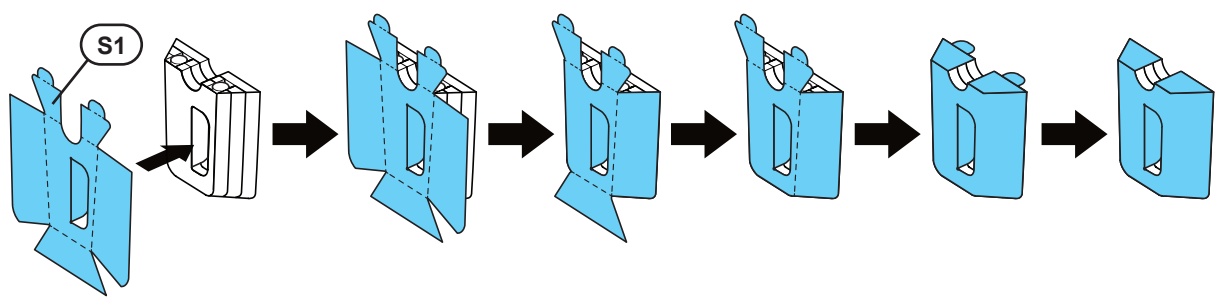

STAGE 1 ENGINE NACELLE

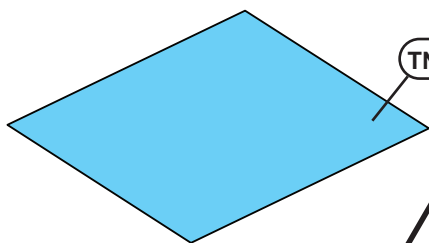
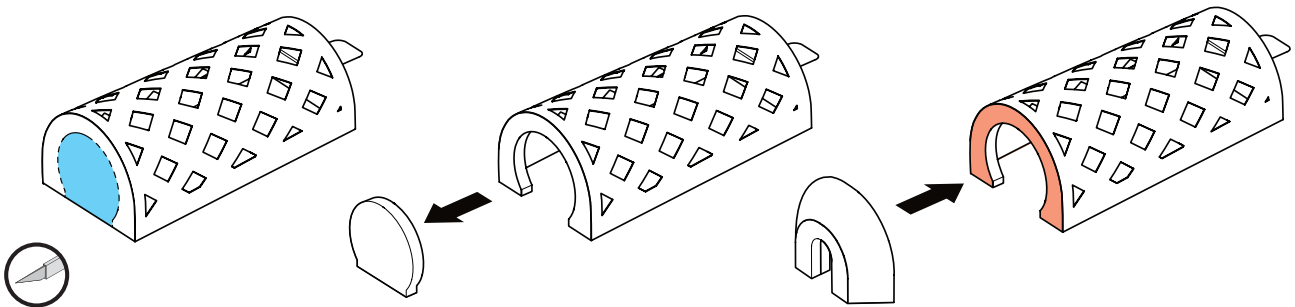
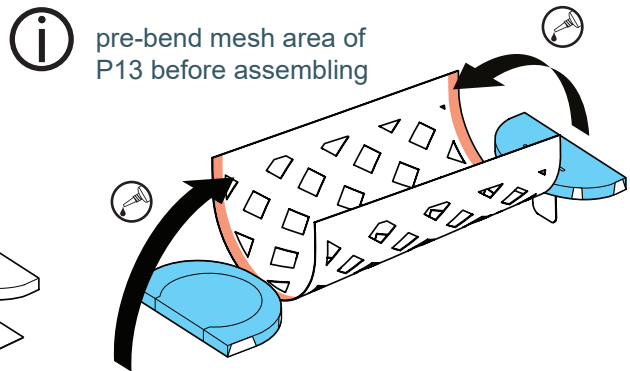
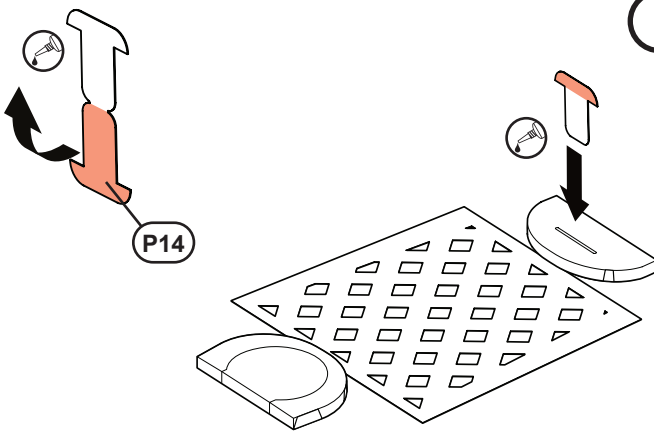
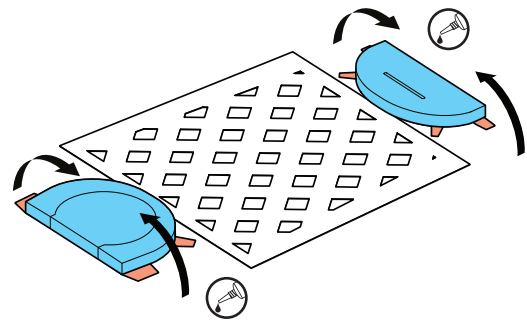
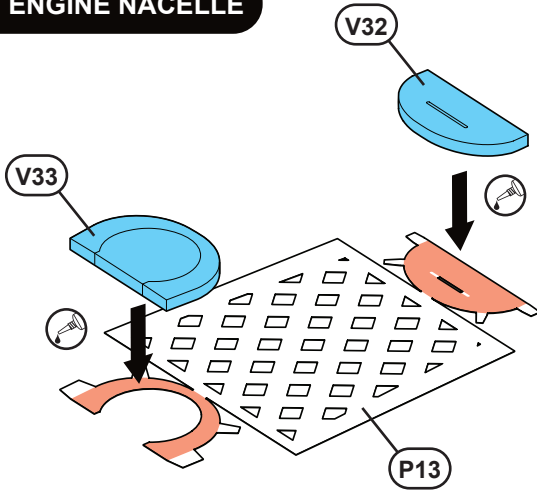

TN7 TN10 - required on second Nacelle build

! See Important Information on gluing Tyvek before proceeding

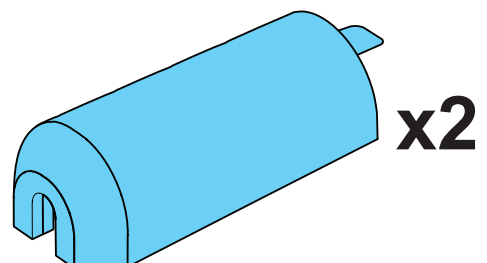
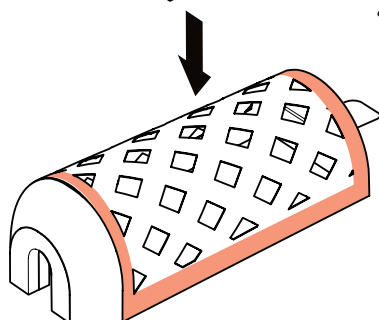

STAGE 2 FUSELAGE

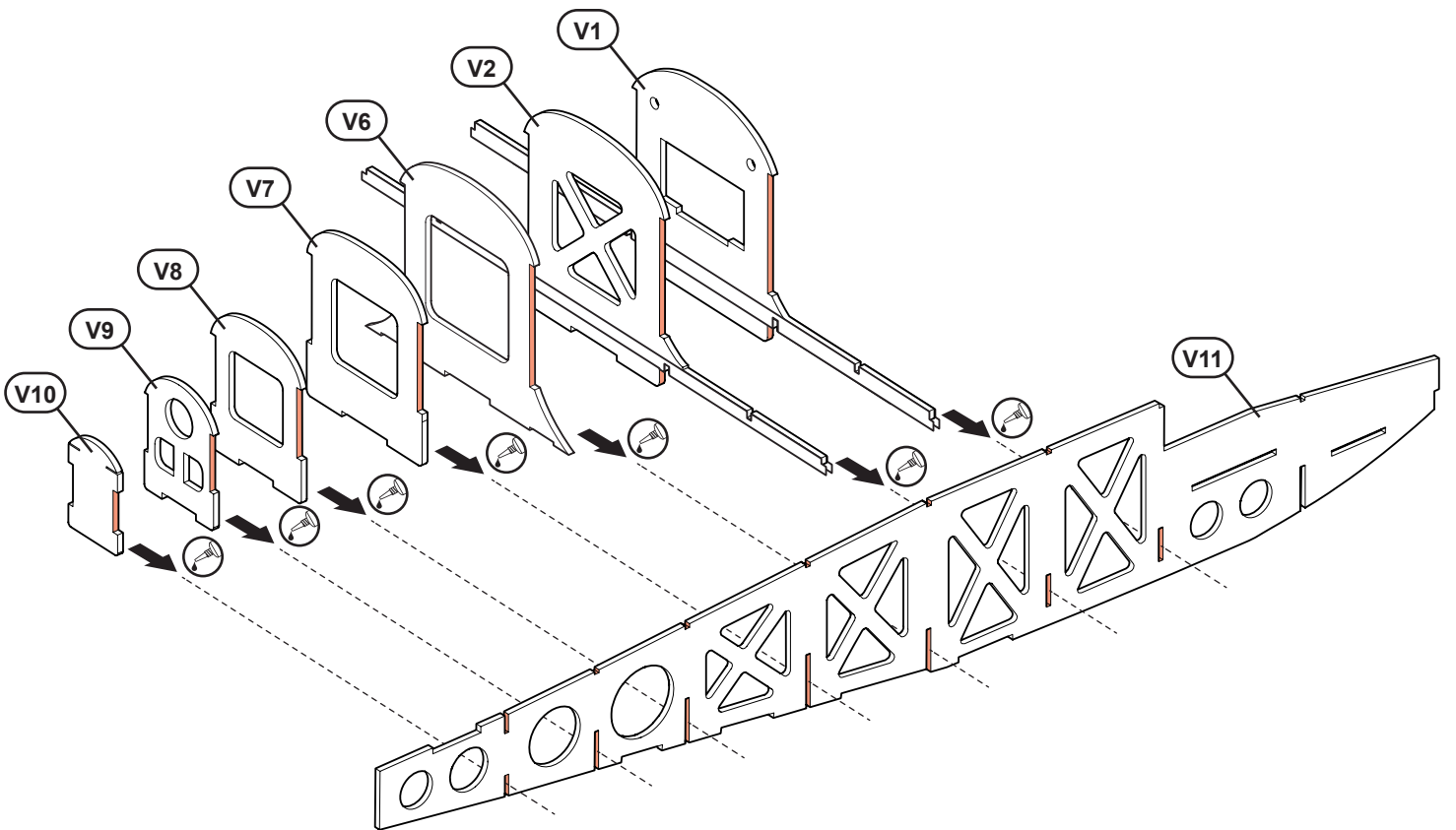
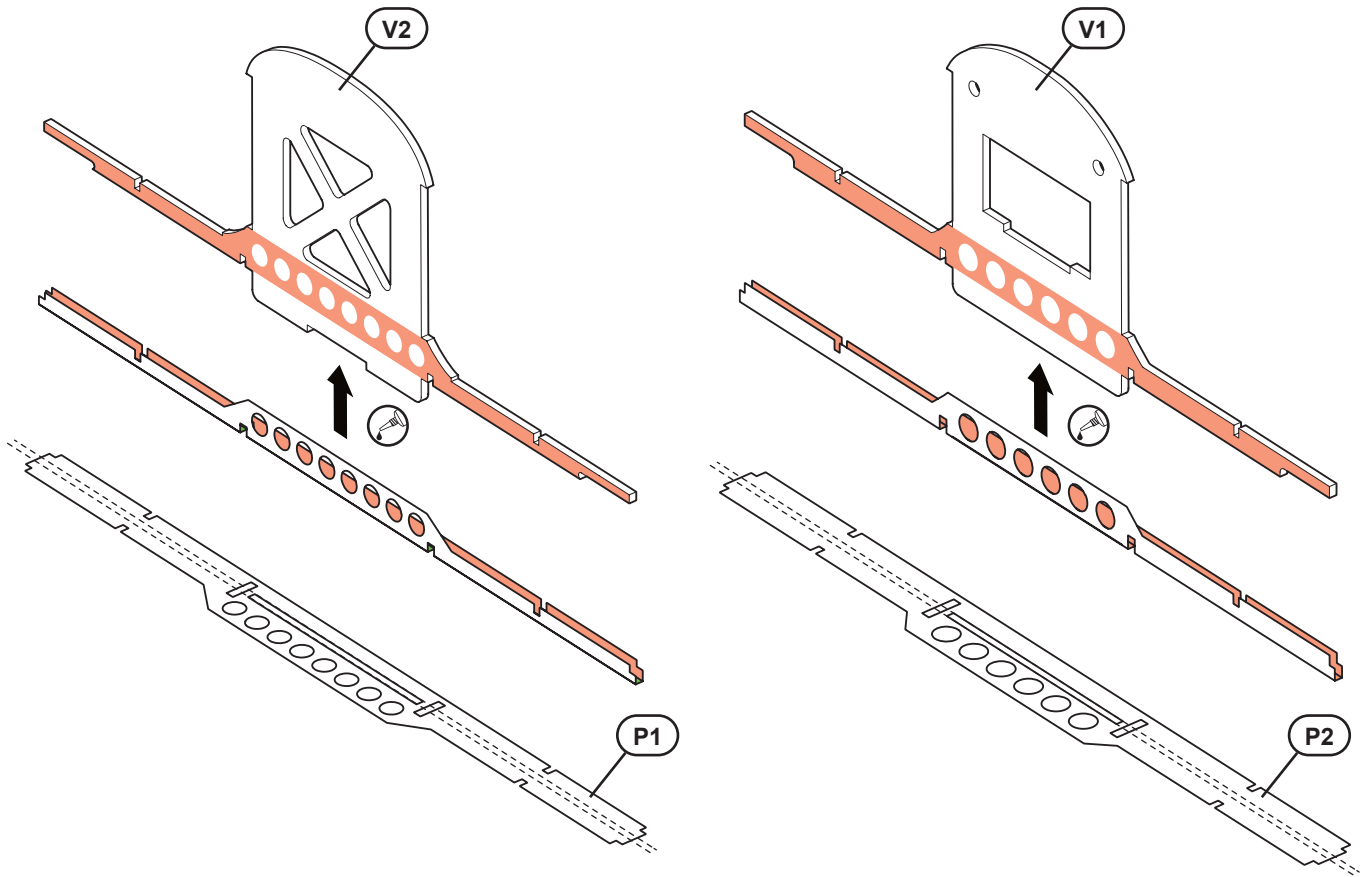

STAGE 2 FUSELAGE

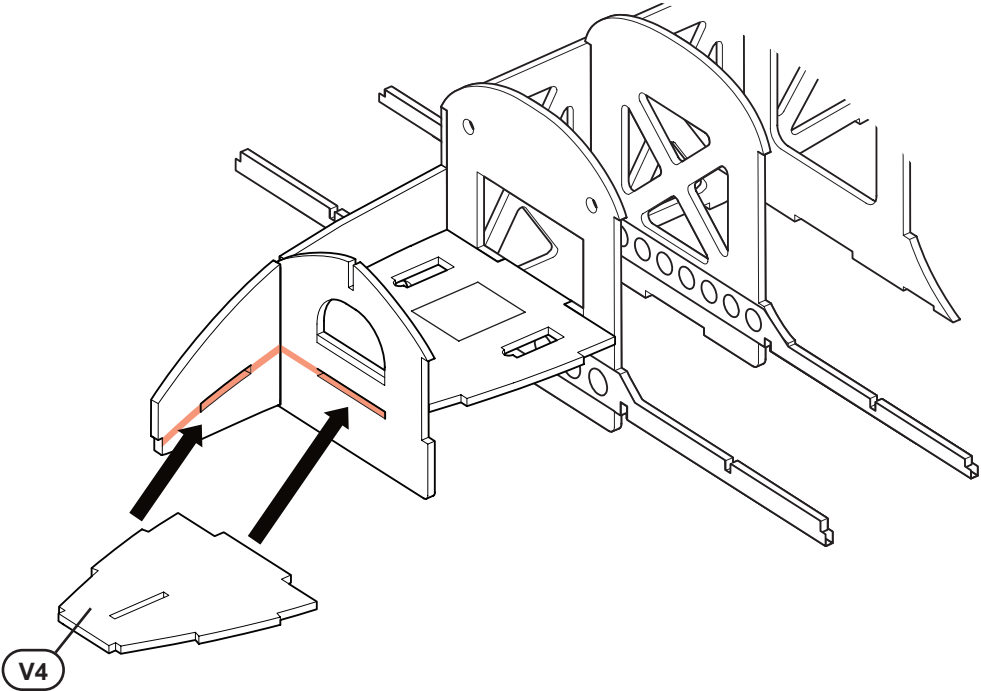
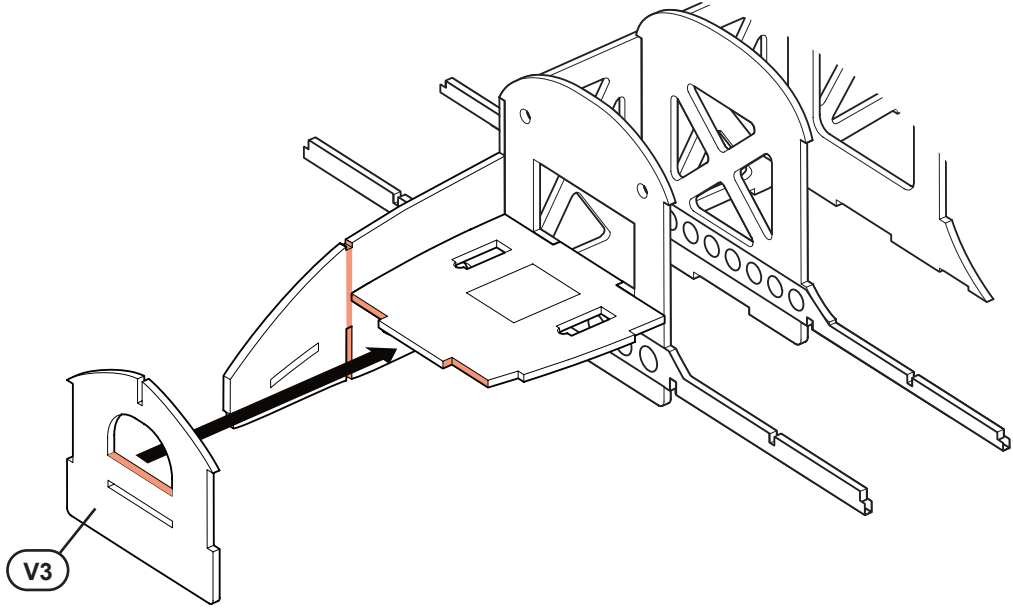
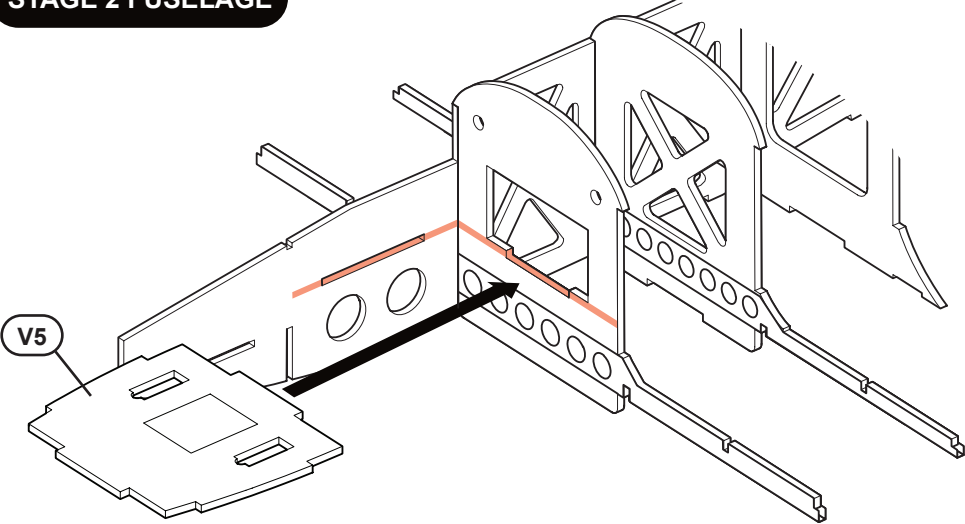

STAGE 2 FUSELAGE

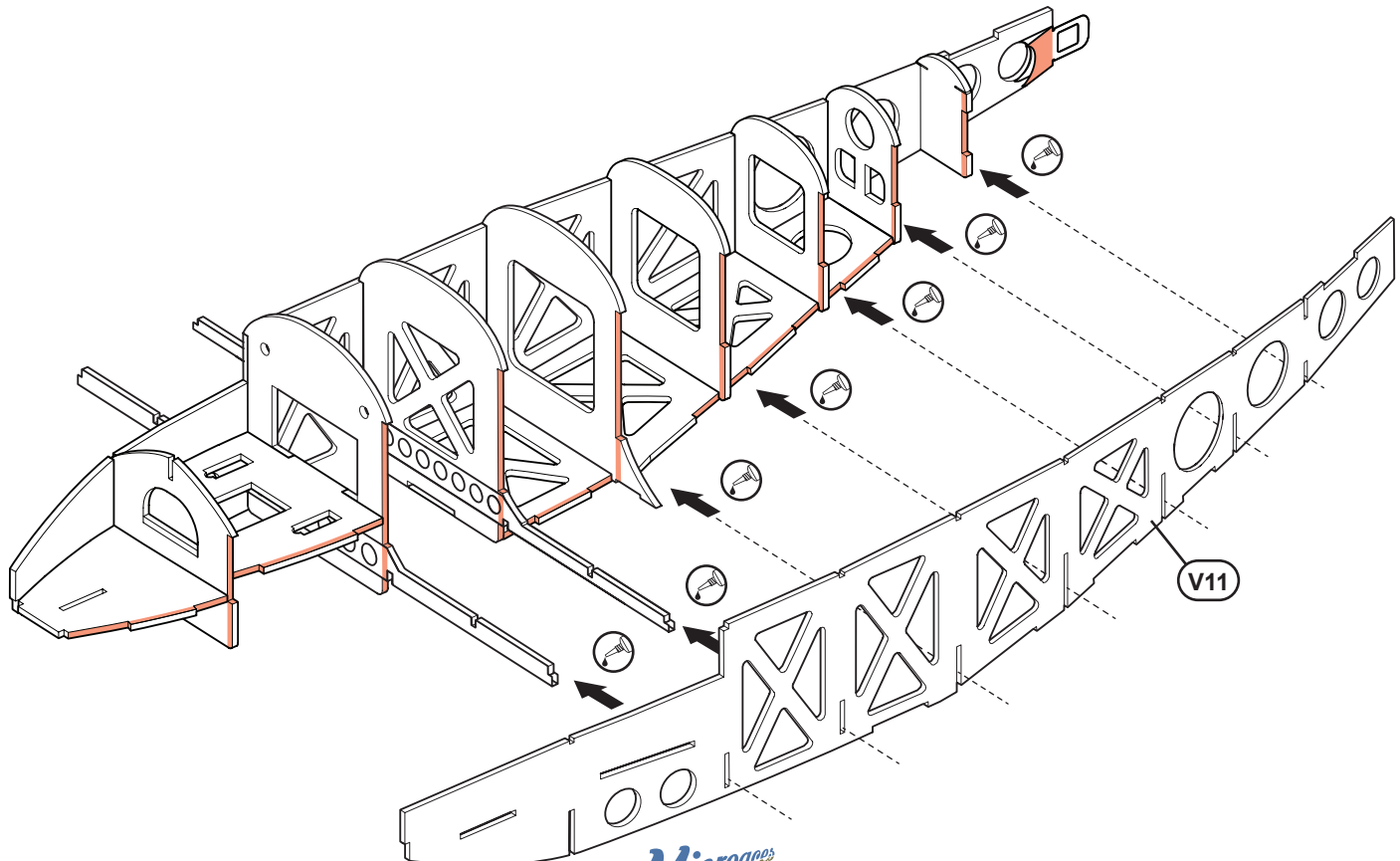
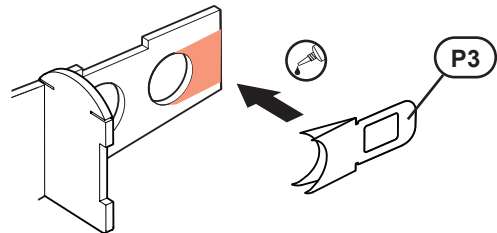
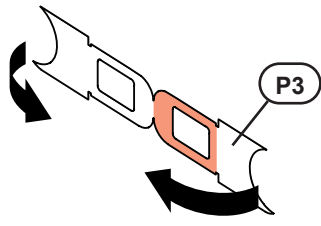
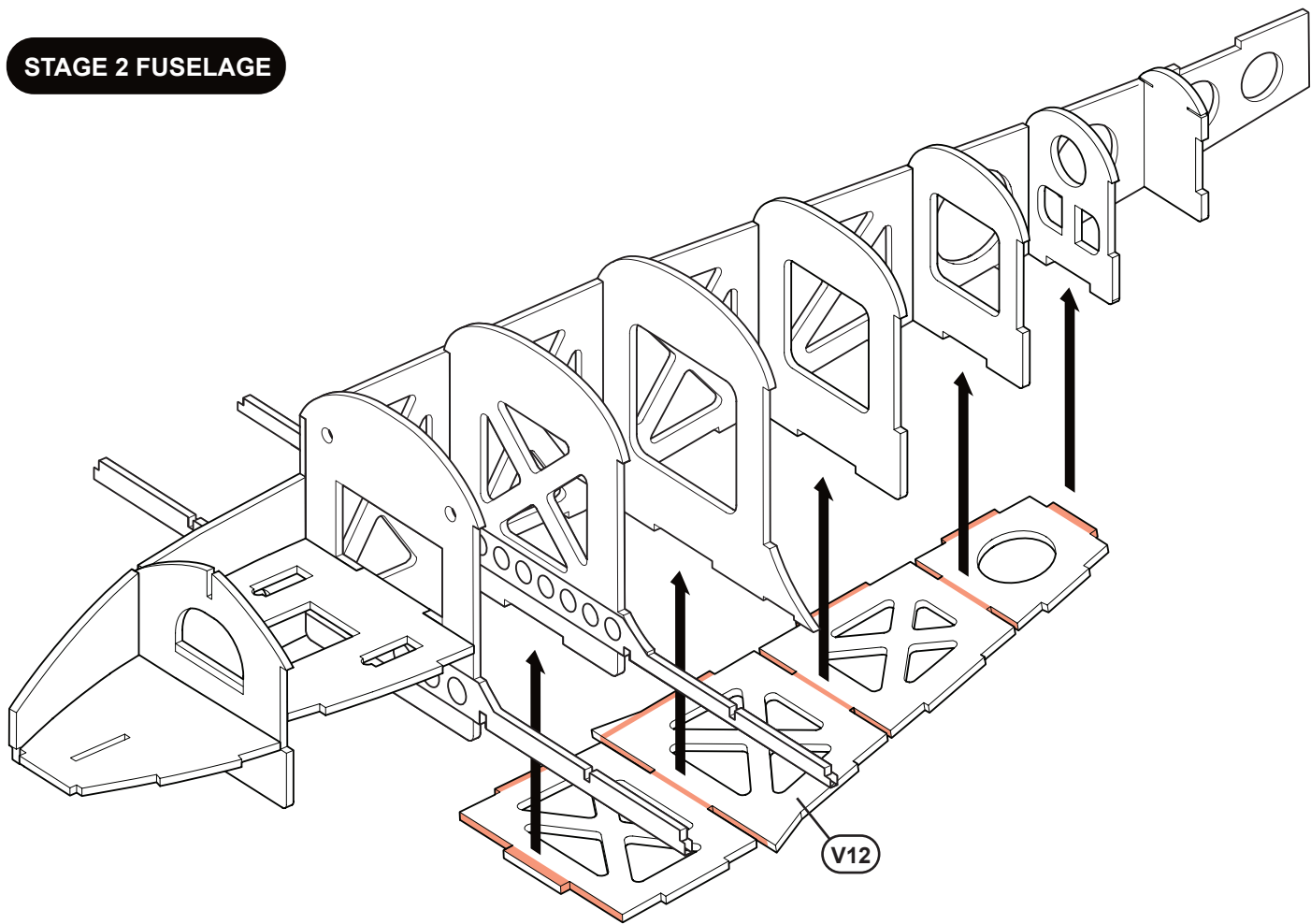

STAGE 2 FUSELAGE

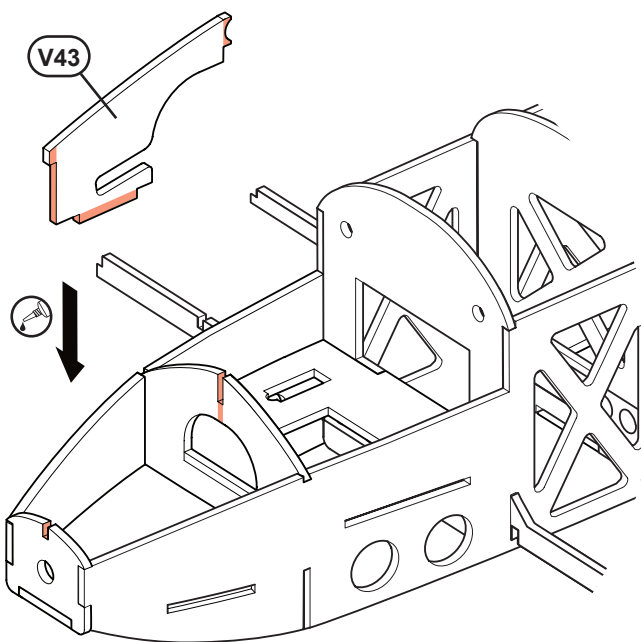
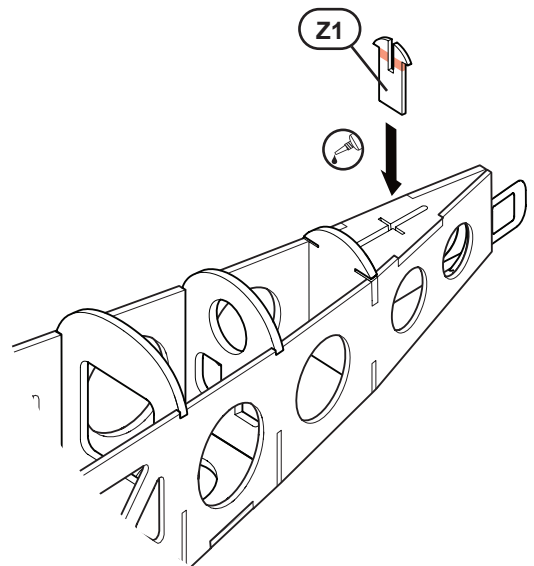
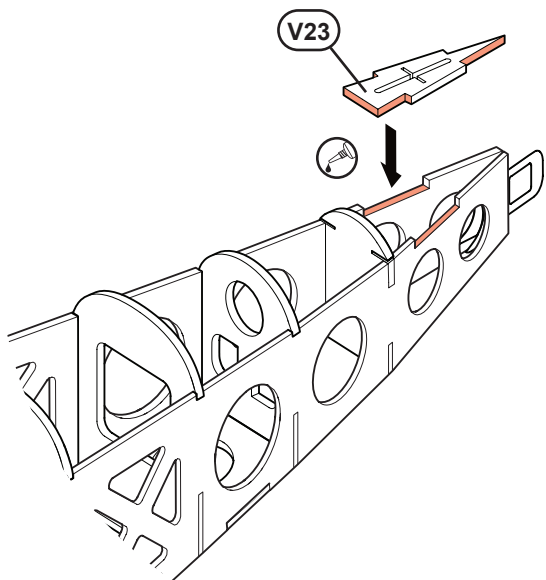
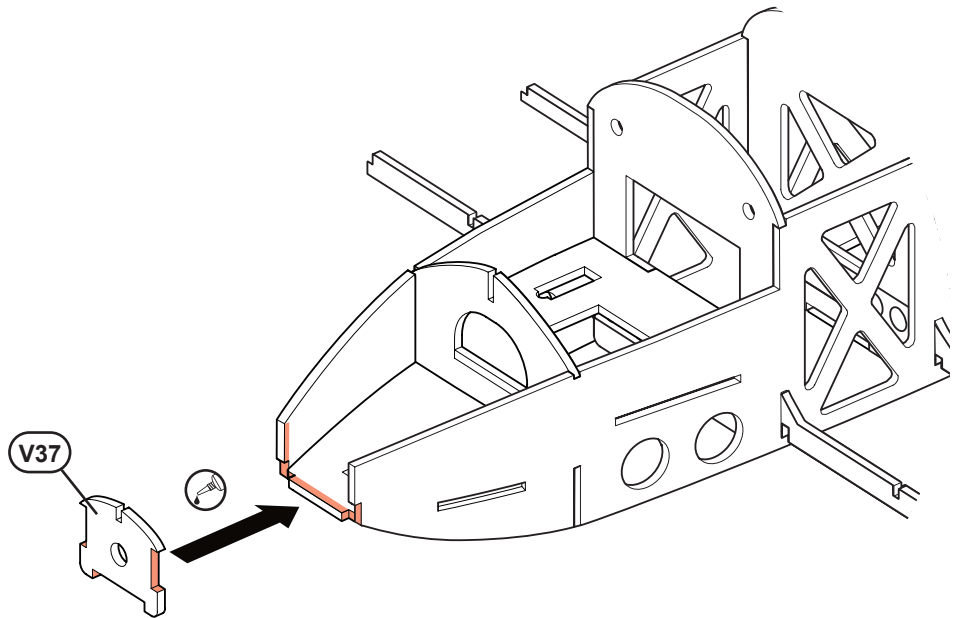

STAGE 2 FUSELAGE



See Important Information on gluing Tyvek before proceeding

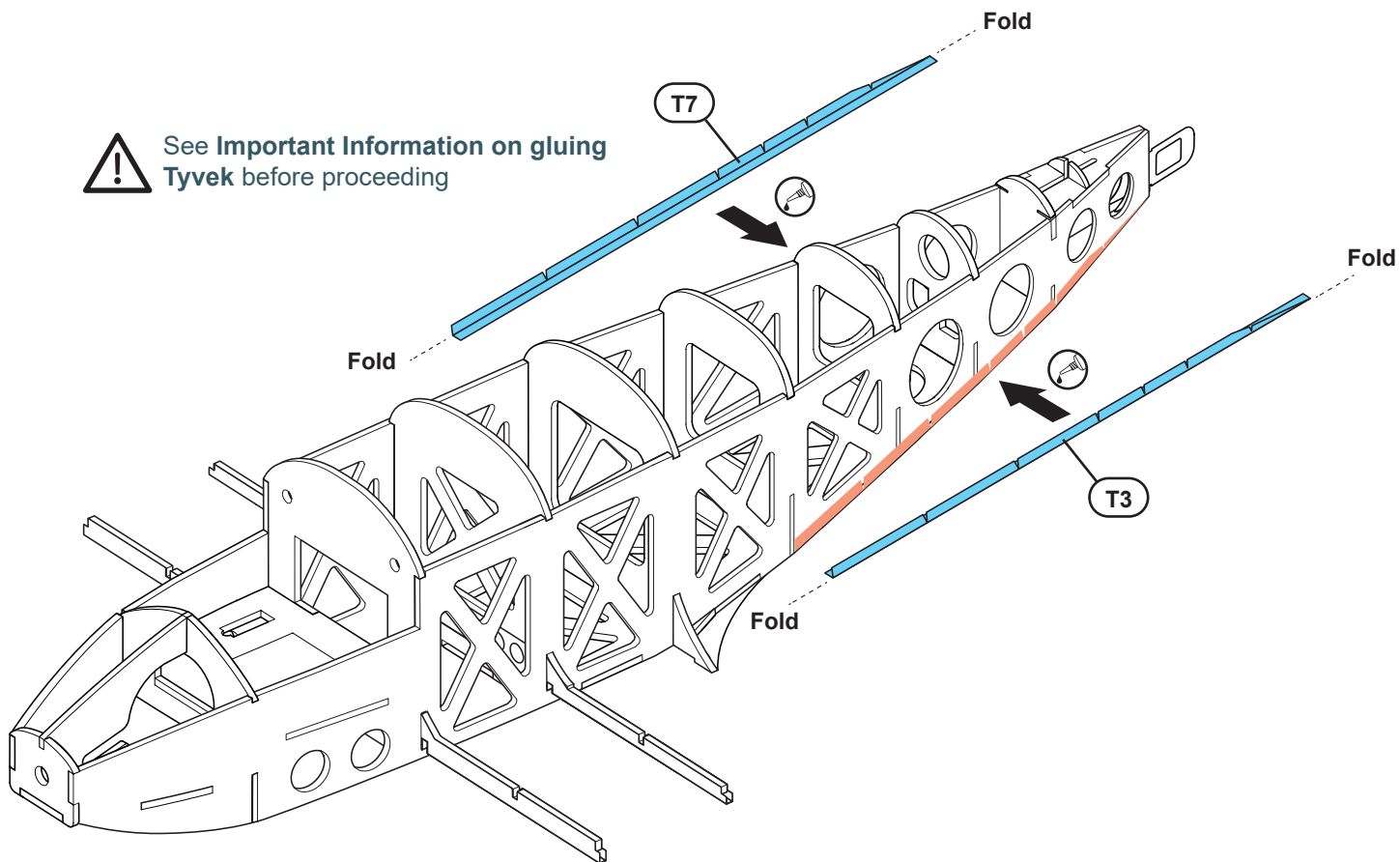

See Important Information on gluing Tyvek before proceeding

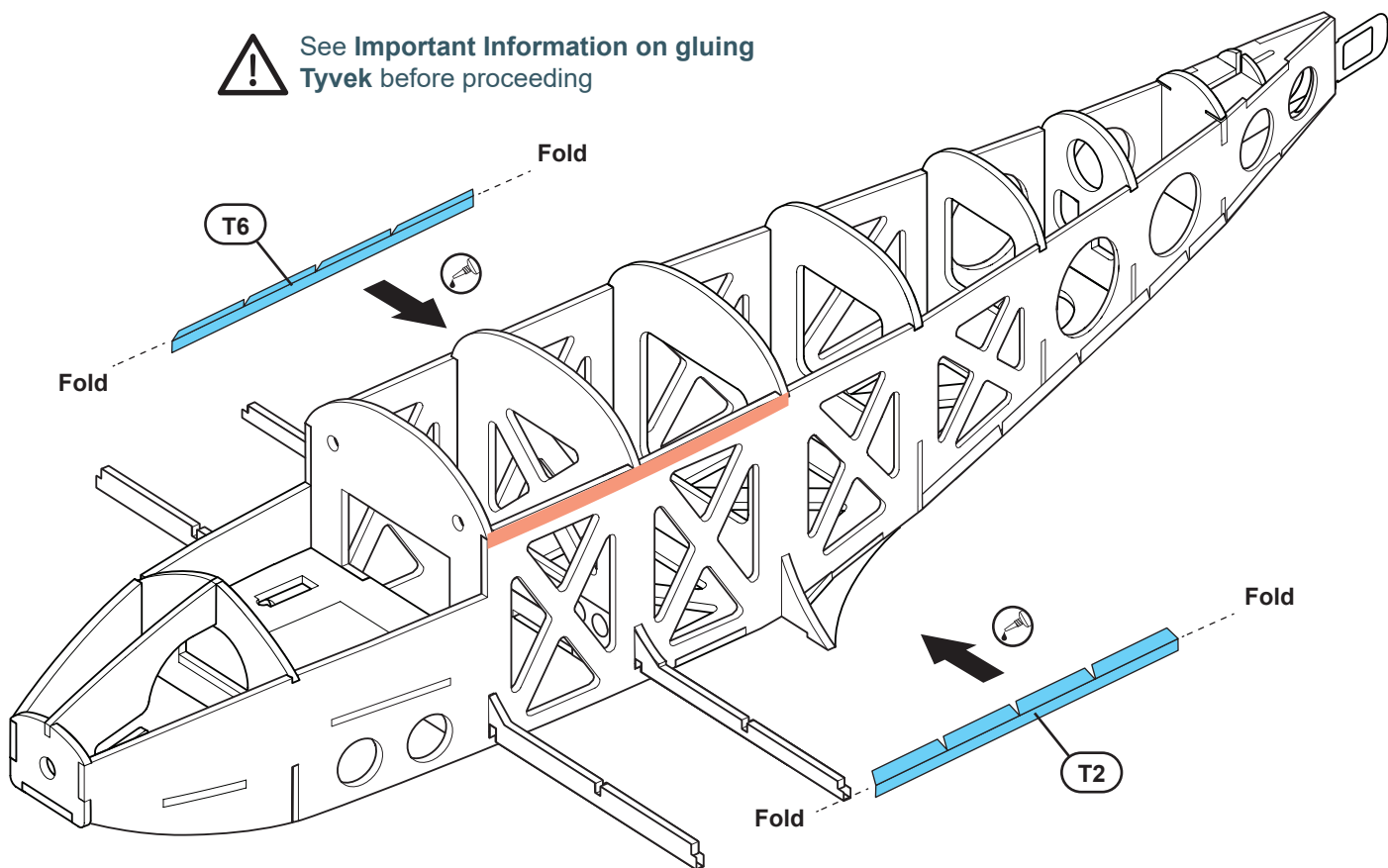

STAGE 2 FUSELAGE



See Important Information on gluing Tyvek before proceeding

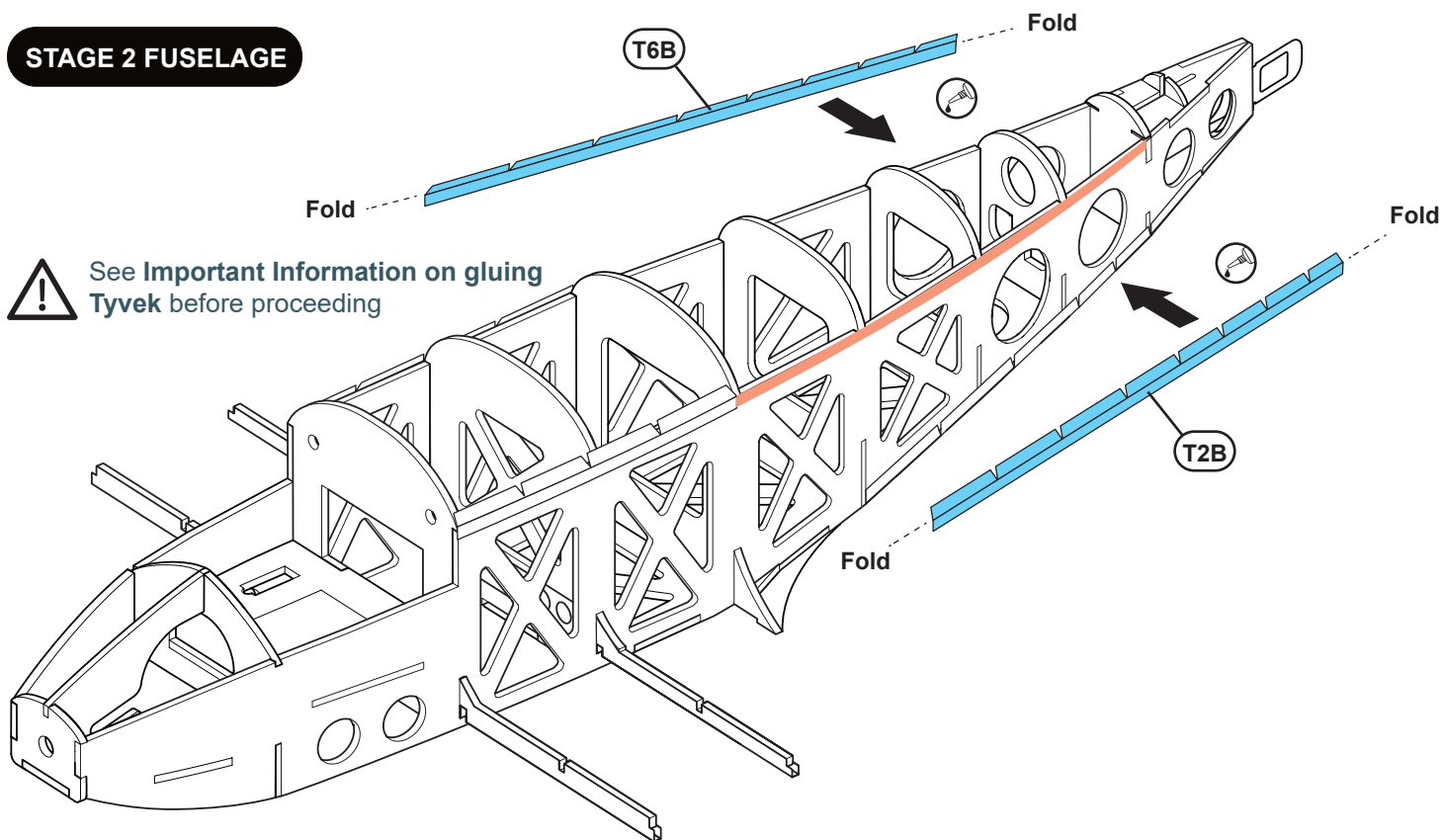

See Important Information on gluing Tyvek before proceeding

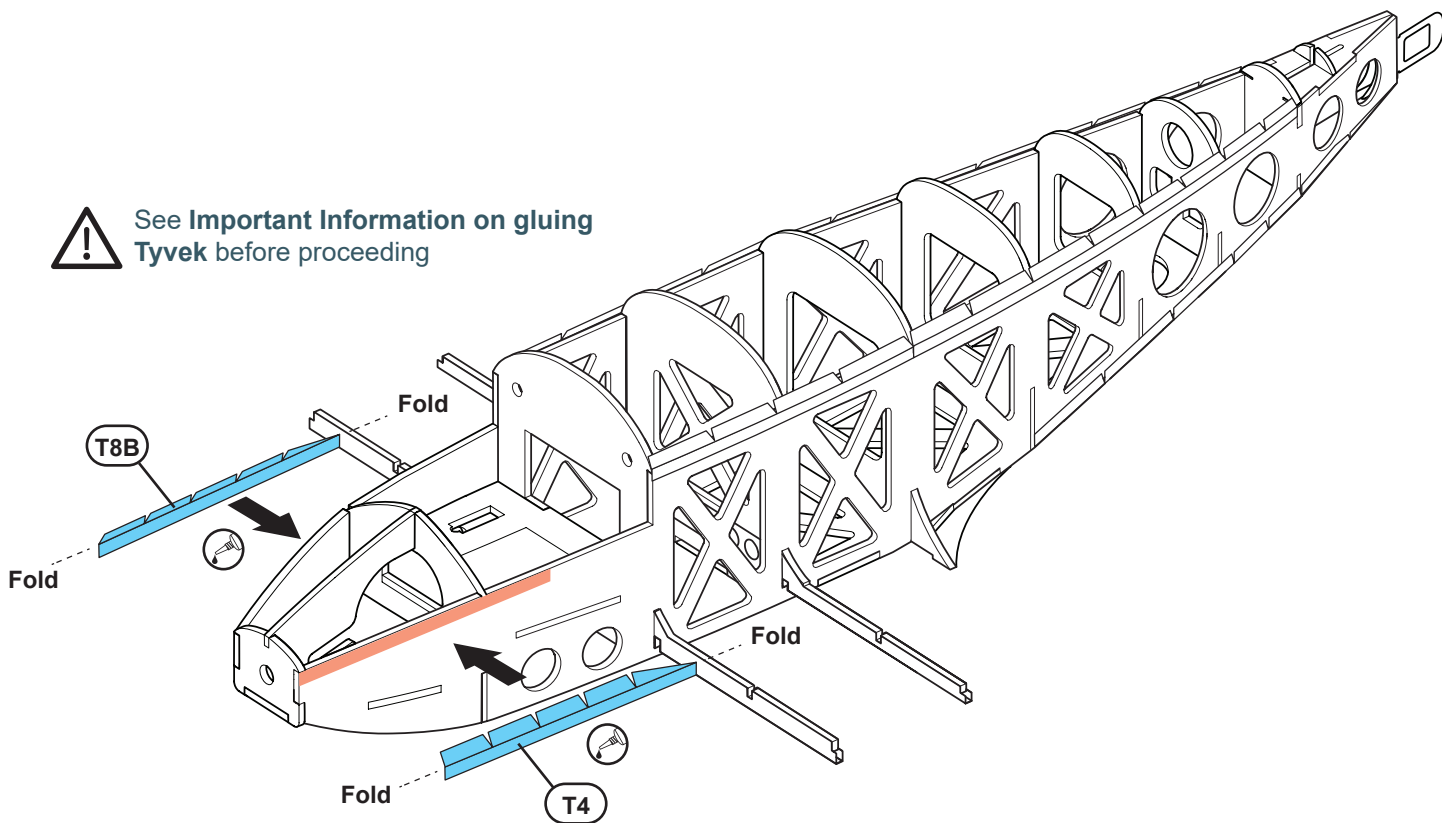

STAGE 2 FUSELAGE



Always Dry fit before gluing



Add glue to the surface the highlighted area comes into contact with. Avoid adding glue directly to Tyvek if possible

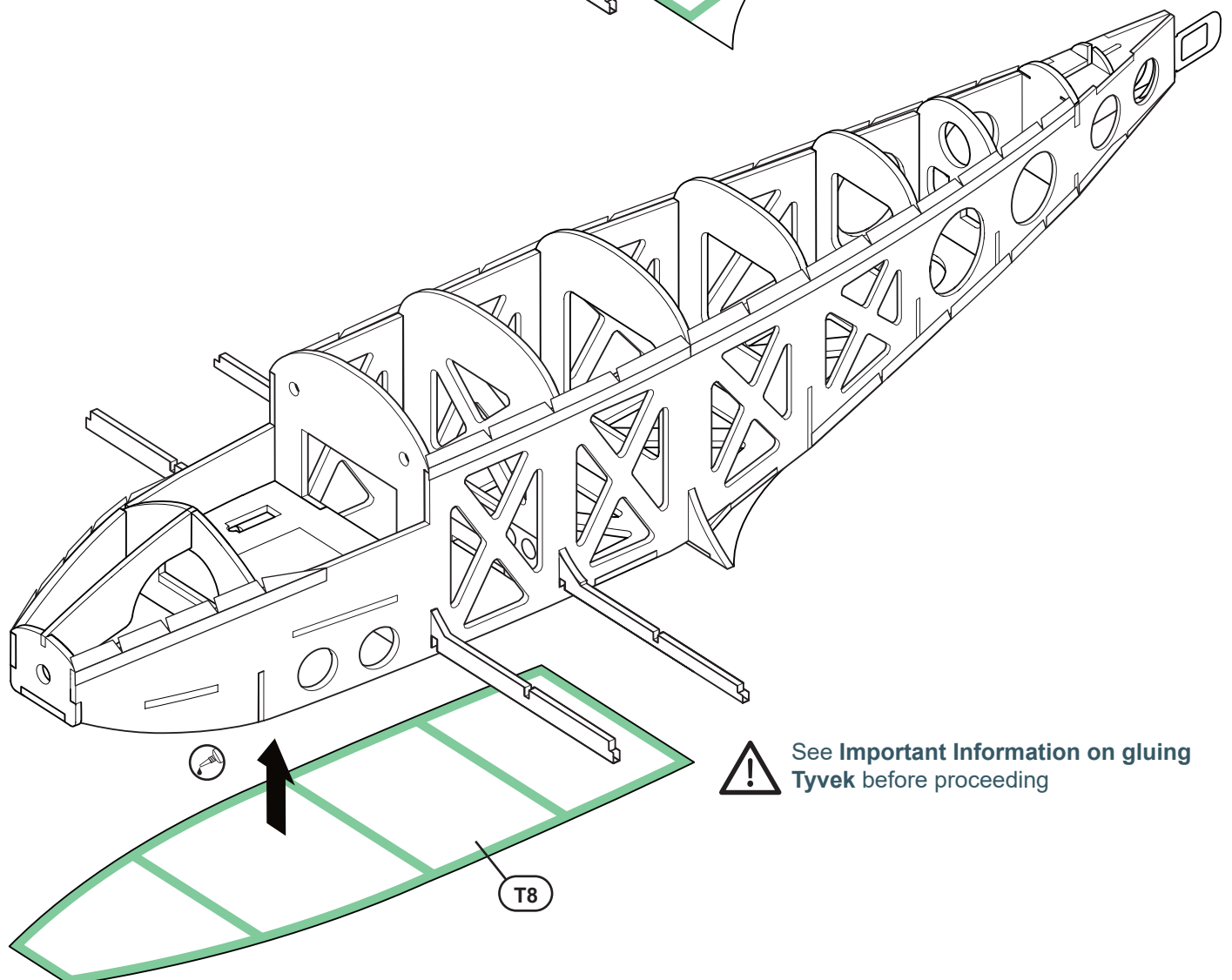
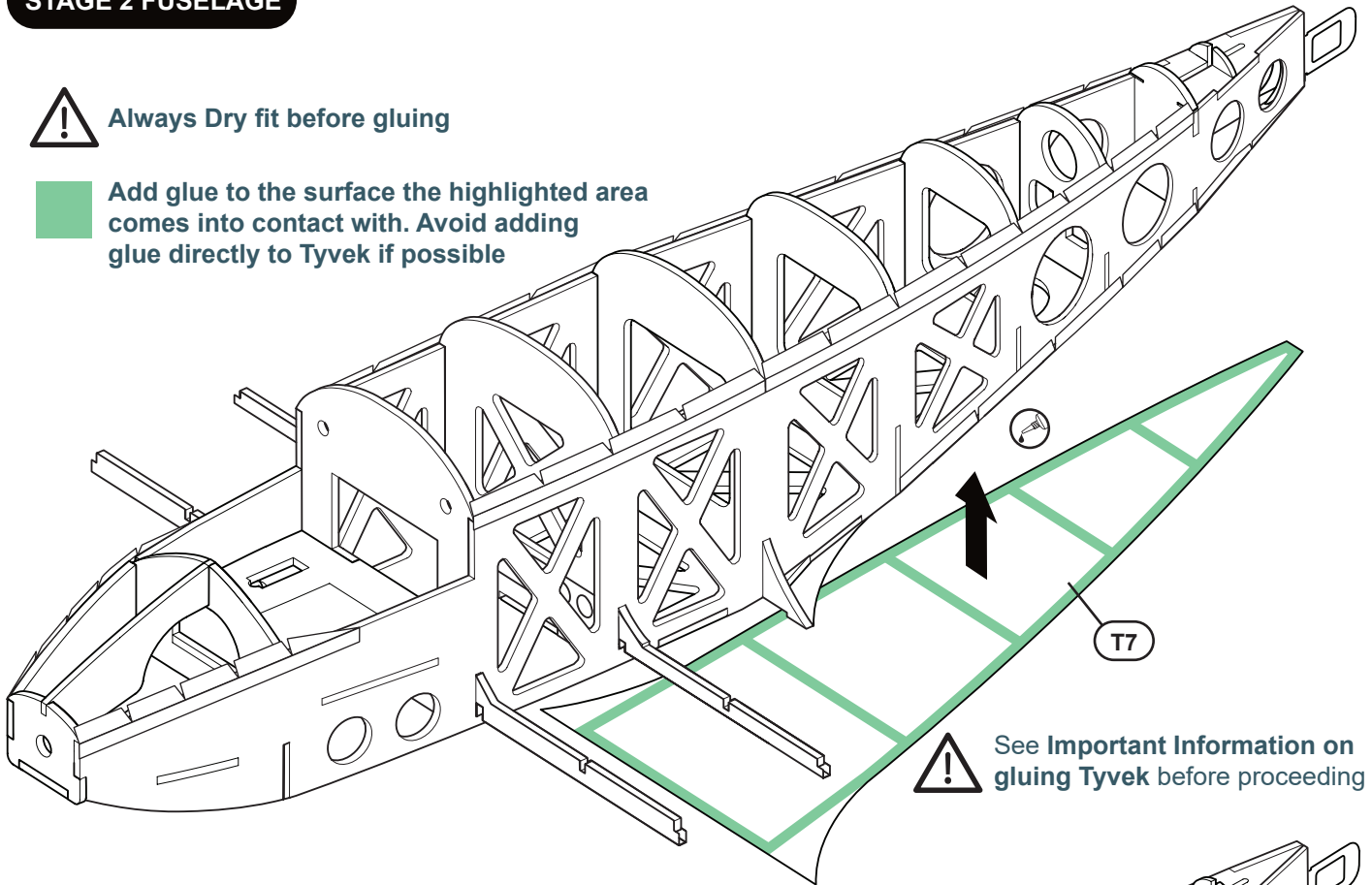

STAGE 2 FUSELAGE

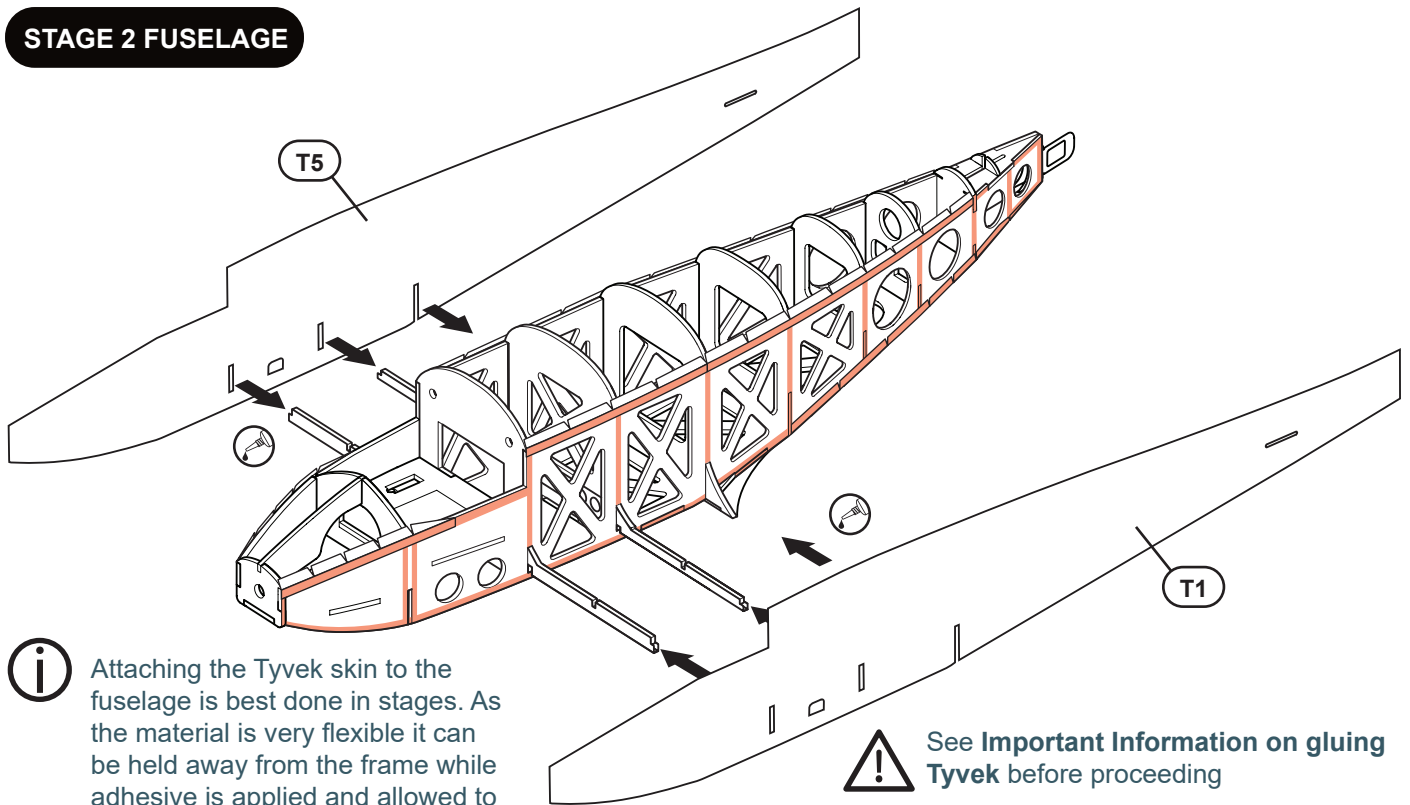

i Attaching the Tyvek skin to the fuselage is best done in stages. As the material is very flexible it can be held away from the frame while adhesive is applied and allowed to dry before assembling

! See **Important Information on gluing Tyvek** before proceeding

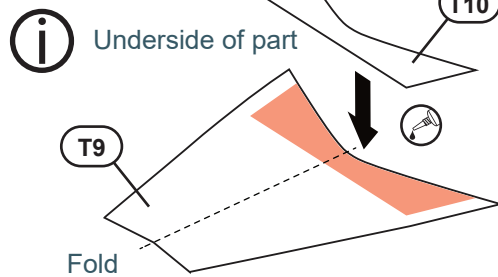
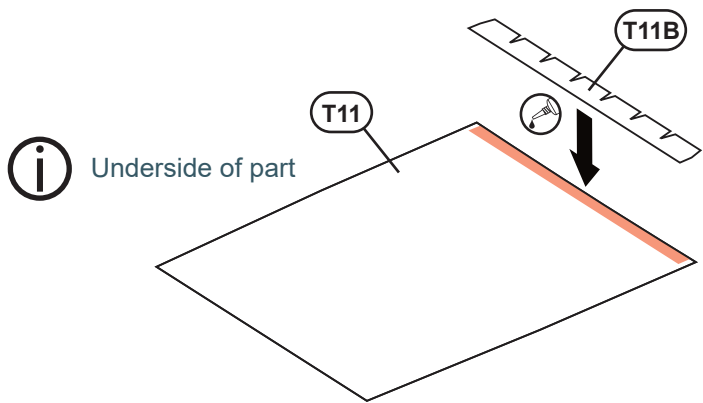

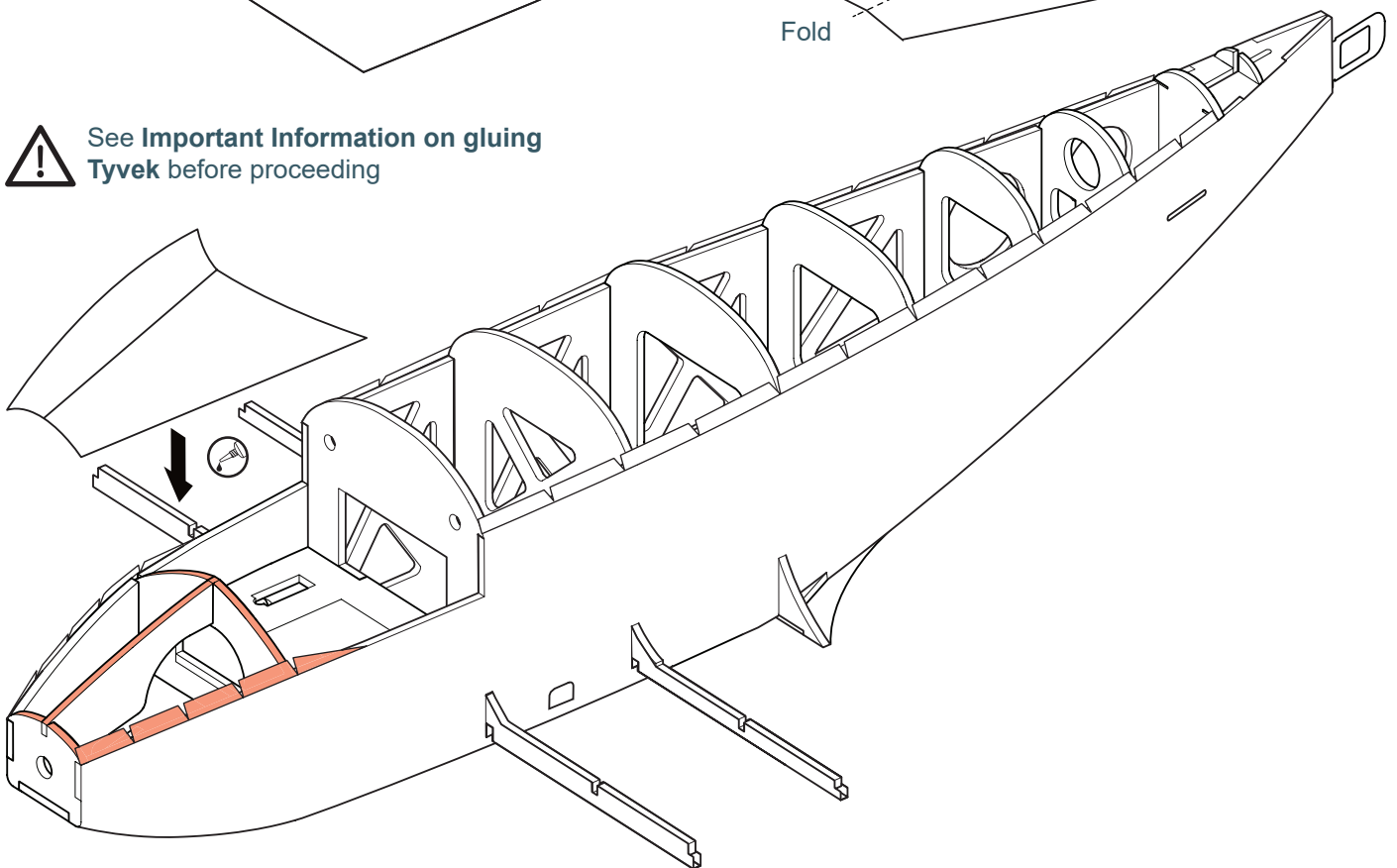

! See **Important Information on gluing Tyvek** before proceeding

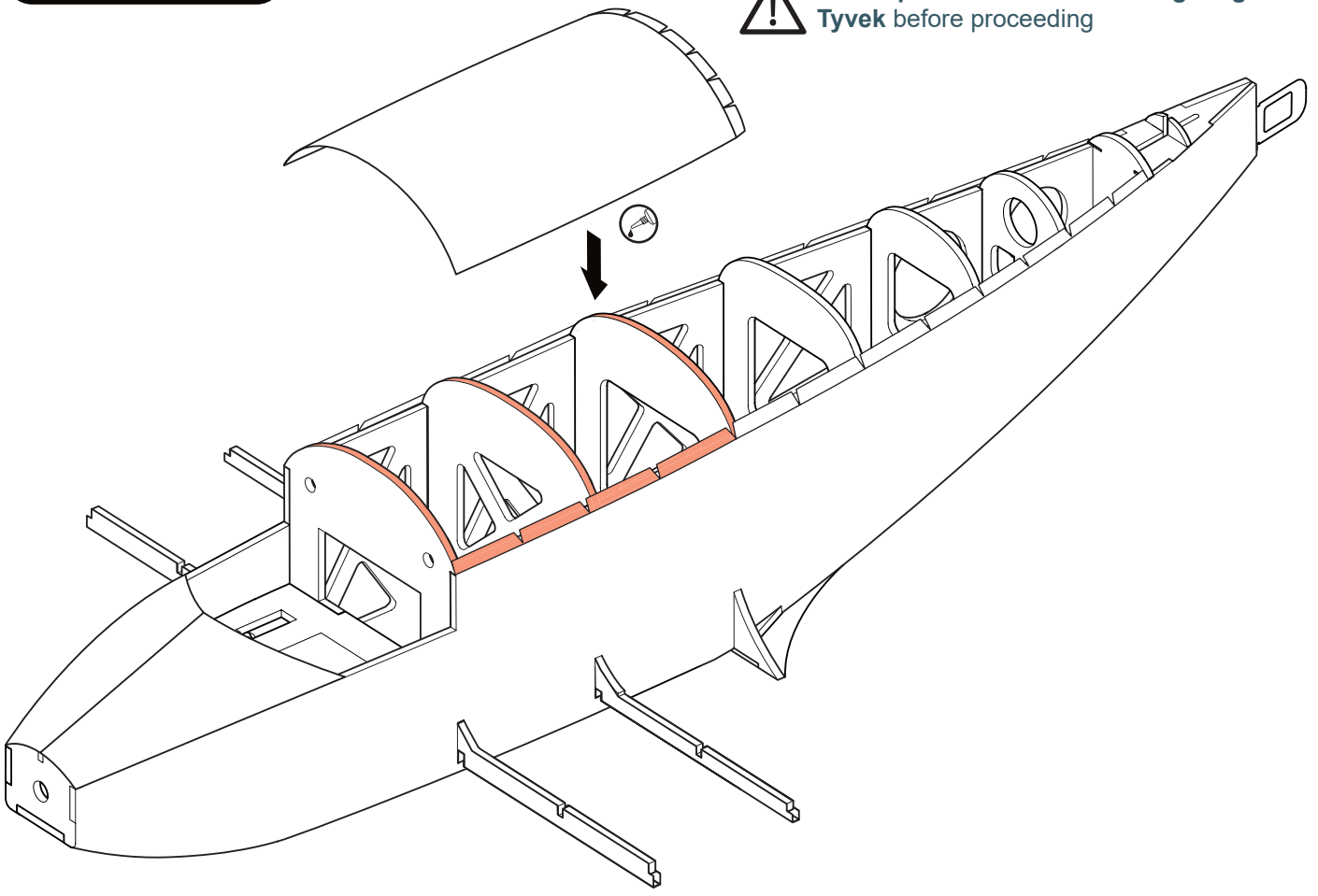

STAGE 2 FUSELAGE

 See Important Information on gluing Tyvek before proceeding



 Score & Bevel before installation - See Scoring & Bevelling guide #2

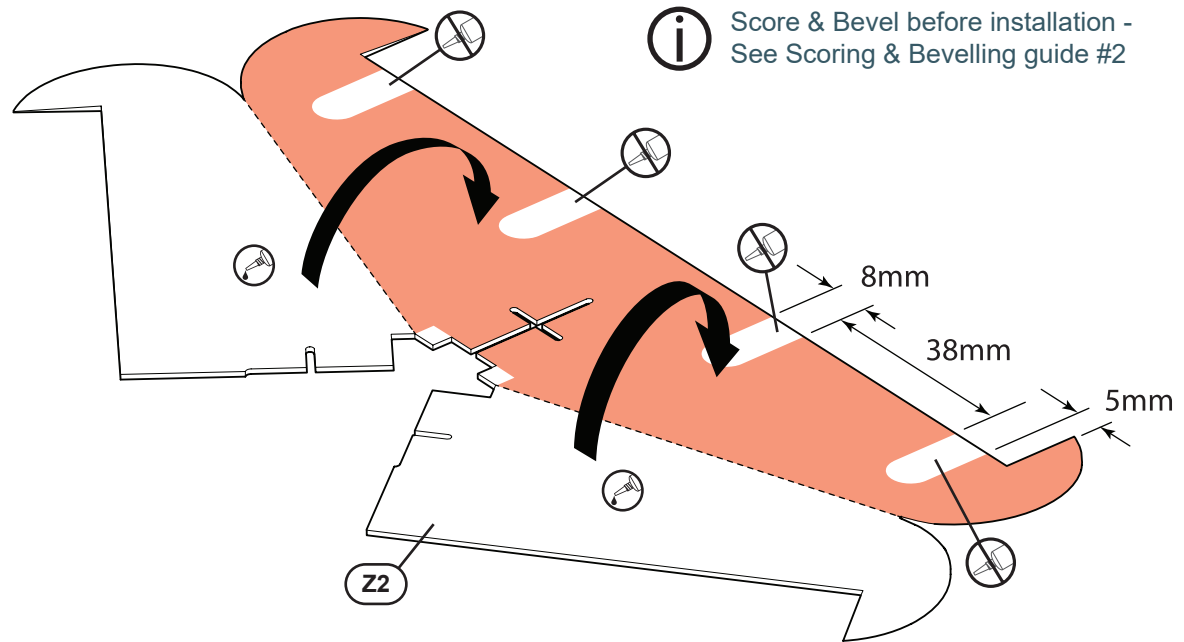

STAGE 2 FUSELAGE

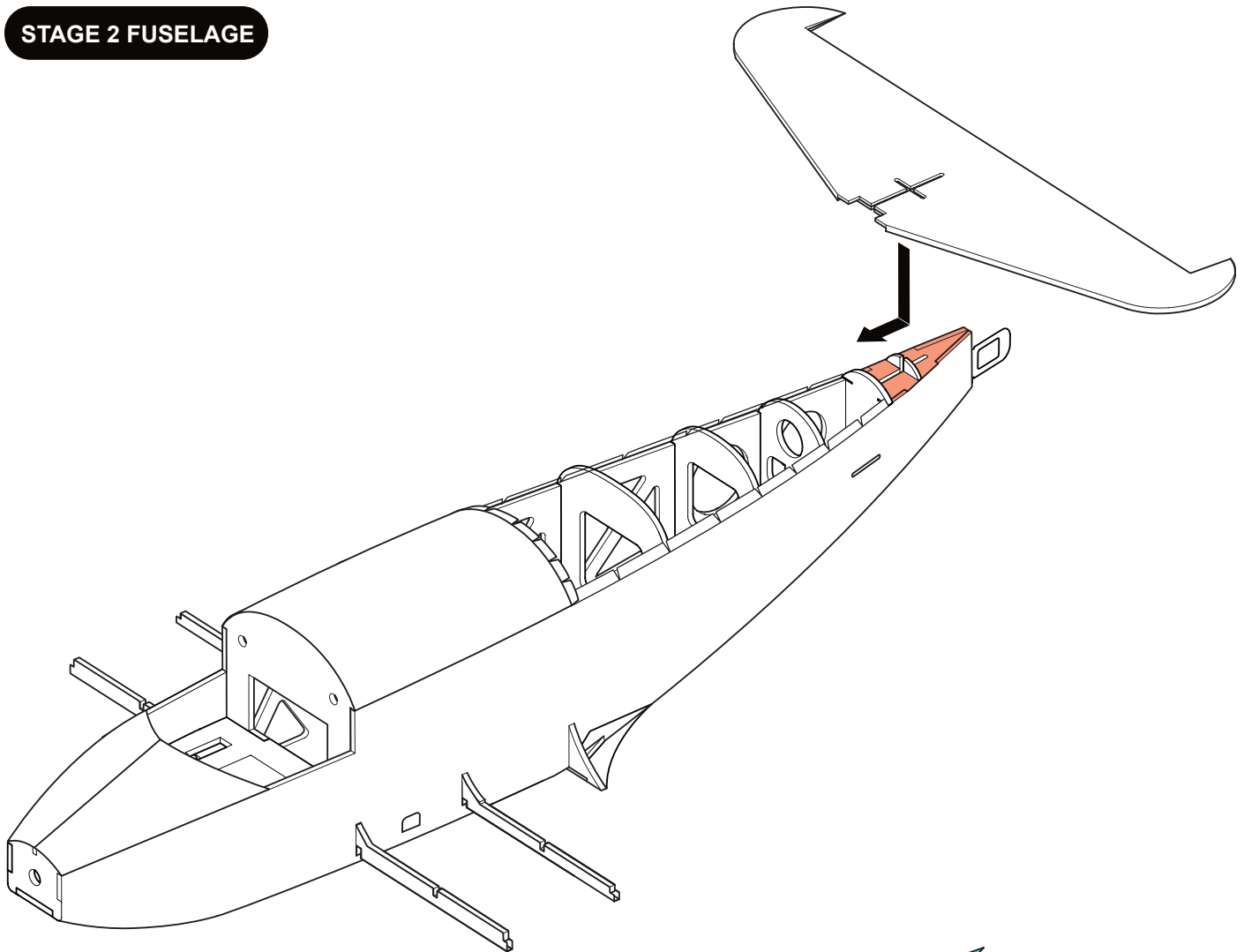

See **Important Information on gluing Tyvek** before proceeding

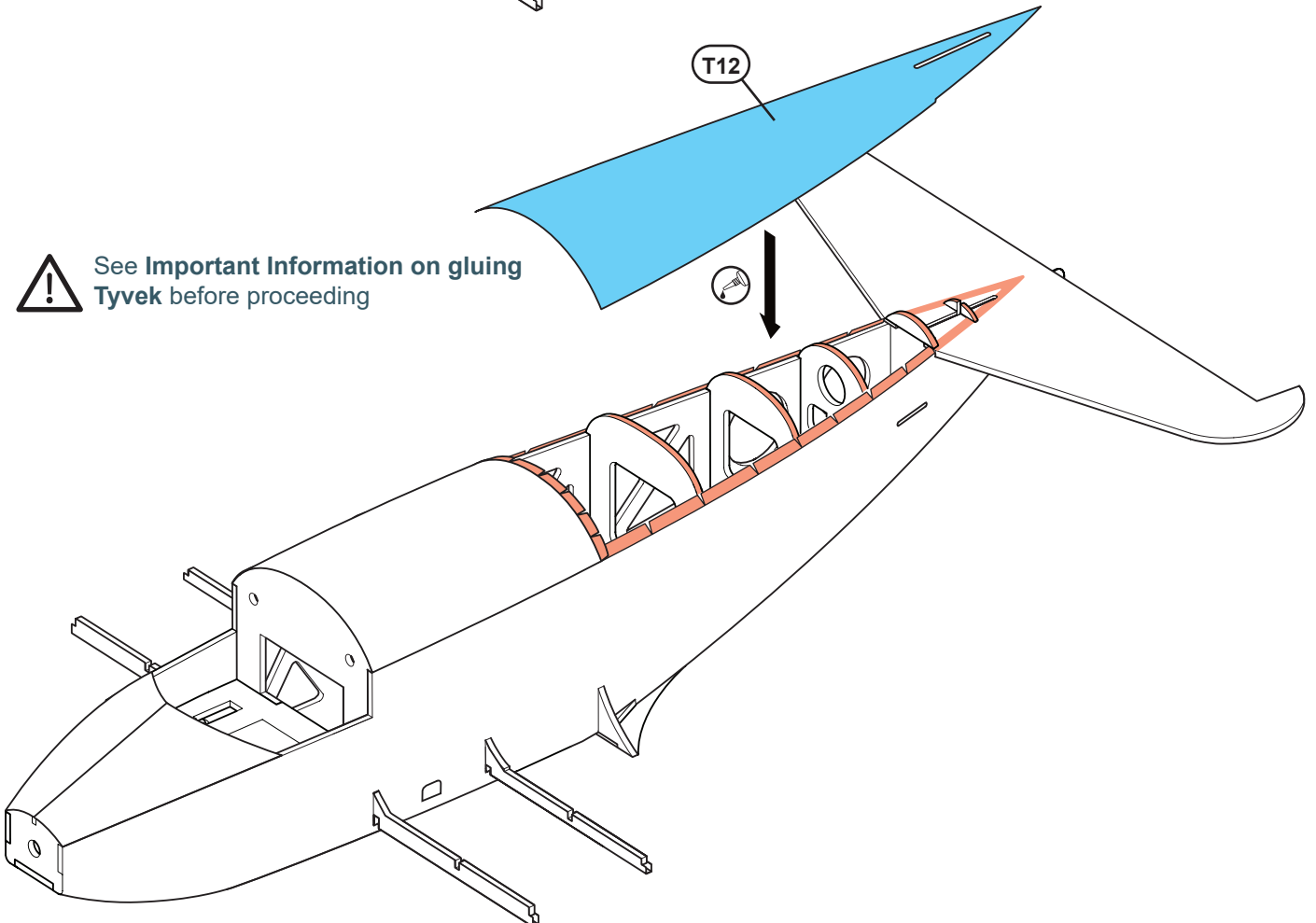

STAGE 3 WINGS

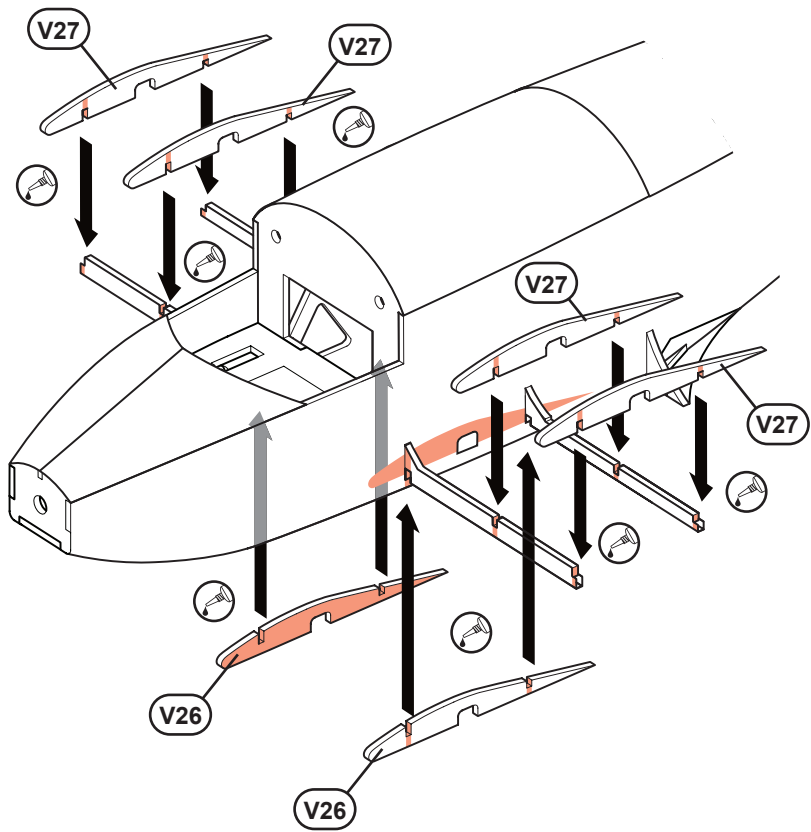

i Score & Bevel before installation -
See Scoring & Beveling guide #2

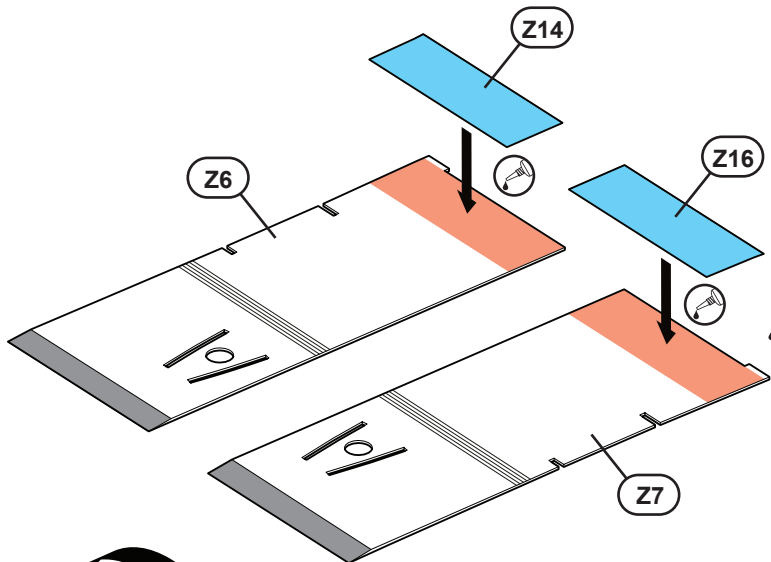

! See Important Information on gluing Tyvek before proceeding

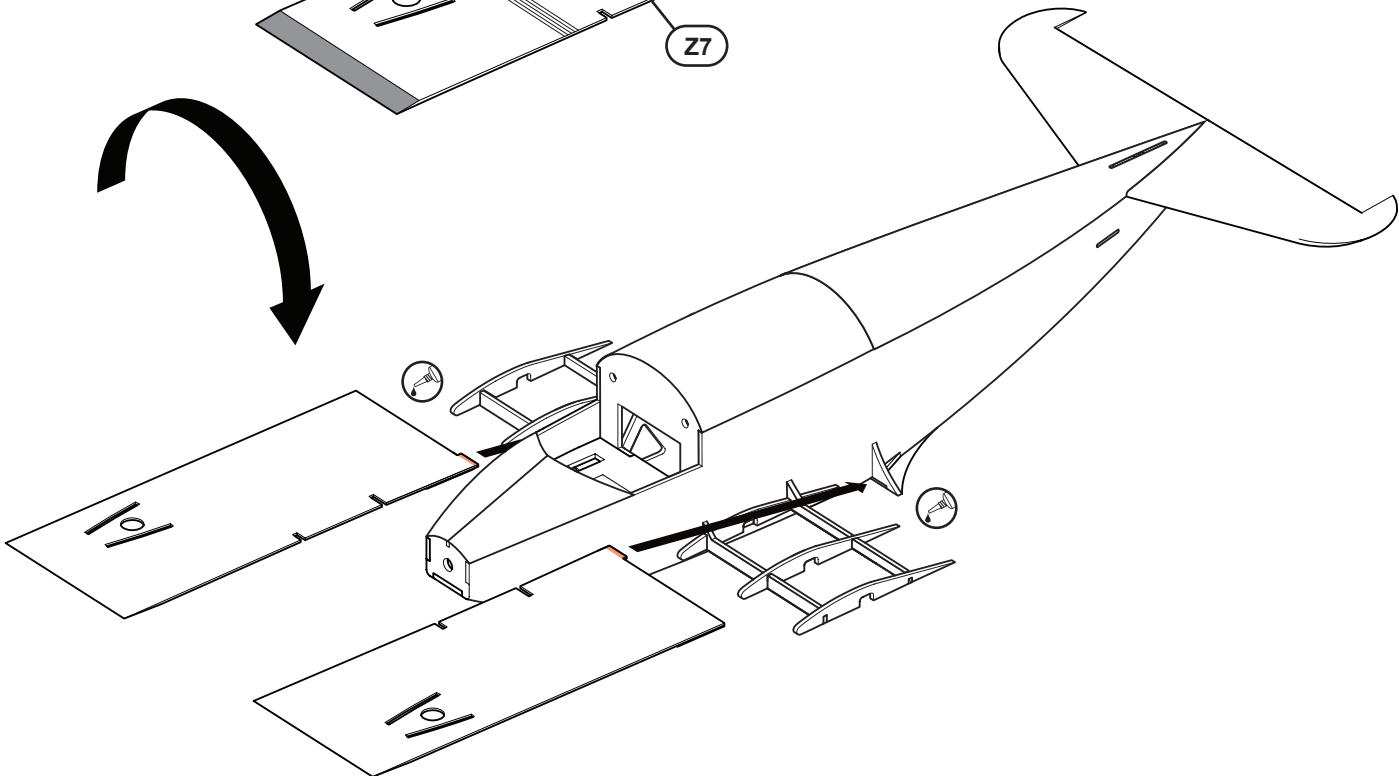

STAGE 3 WINGS



Before installing any electronics, ensure all cables, connectors, extension wires, servos and motors are working by plugging them in to their respective connectors on the receiver, binding the receiver to your transmitter and testing they function as expected.



Install extension wires before the wing skin is attached to the underside



Secure cables in place with small dabs of glue to keep them in place



Aileron servo Y cable extension



Motor extension wires

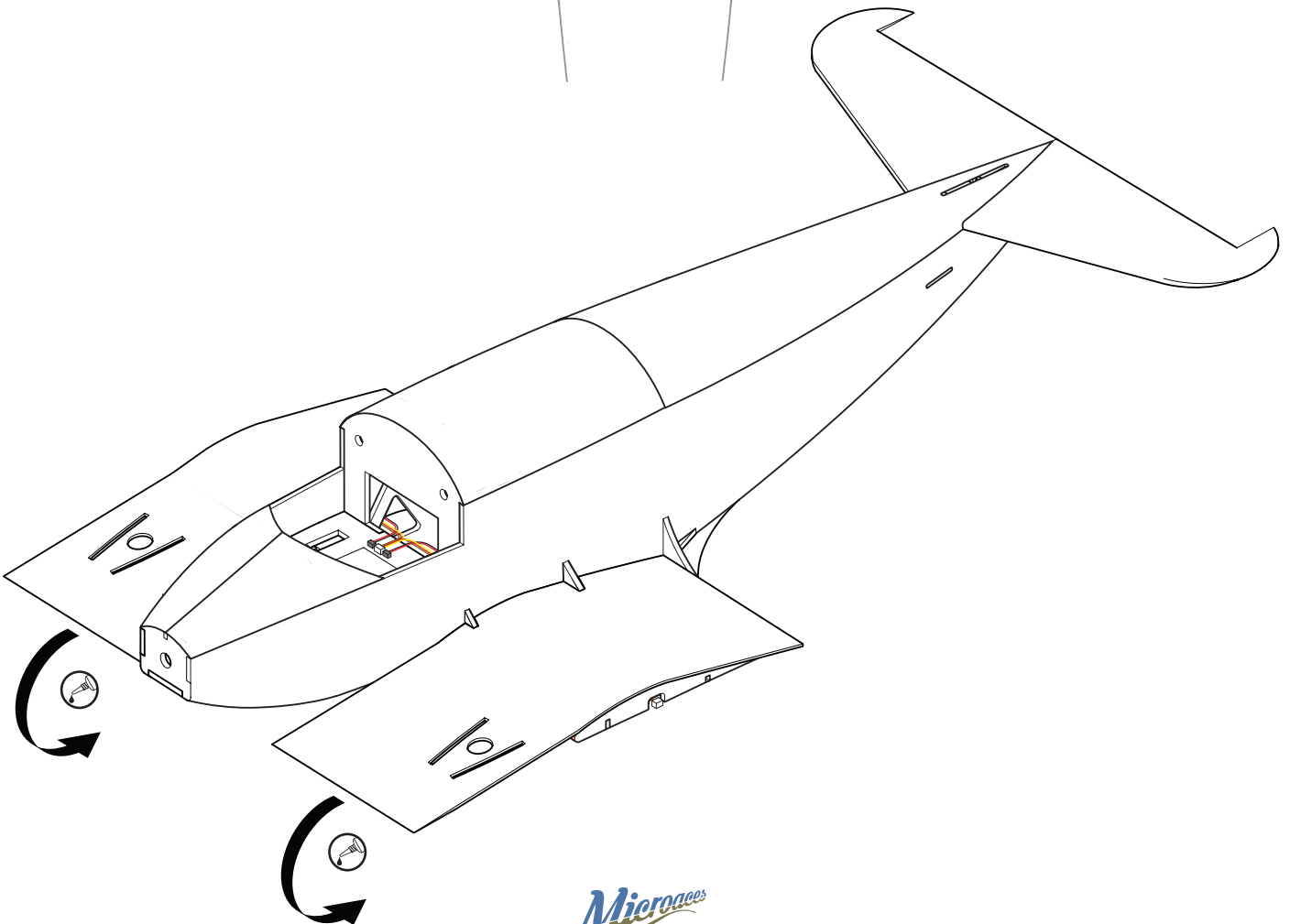
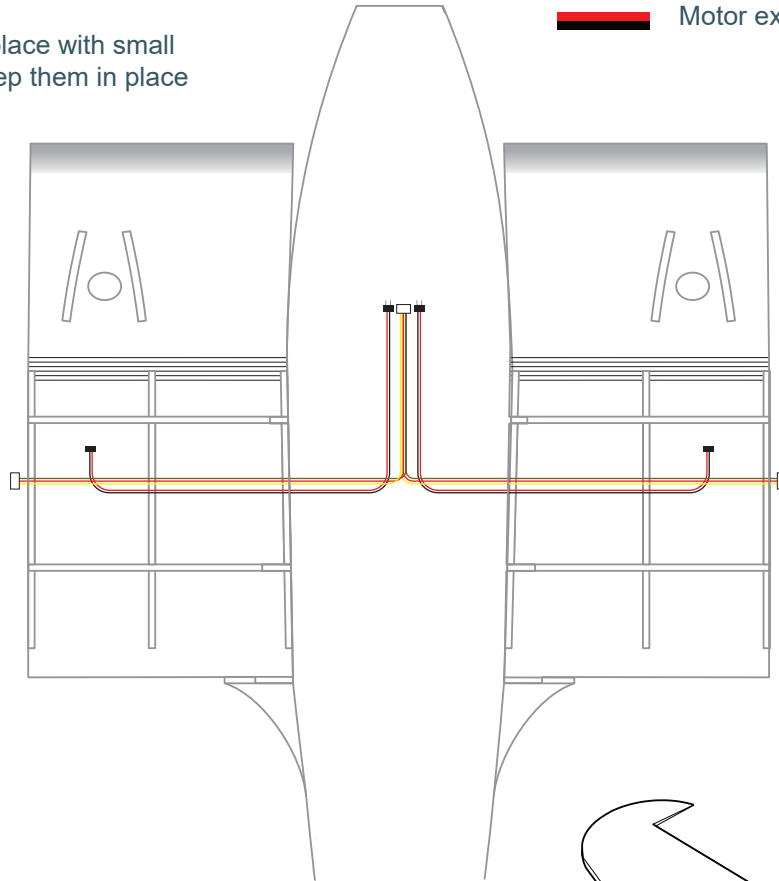

STAGE 3 WINGS

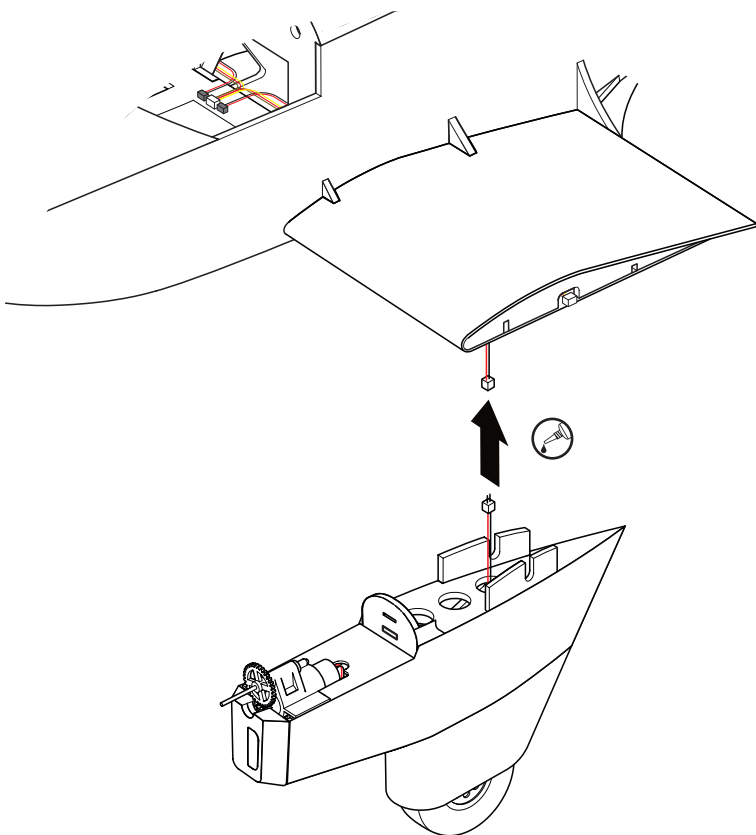
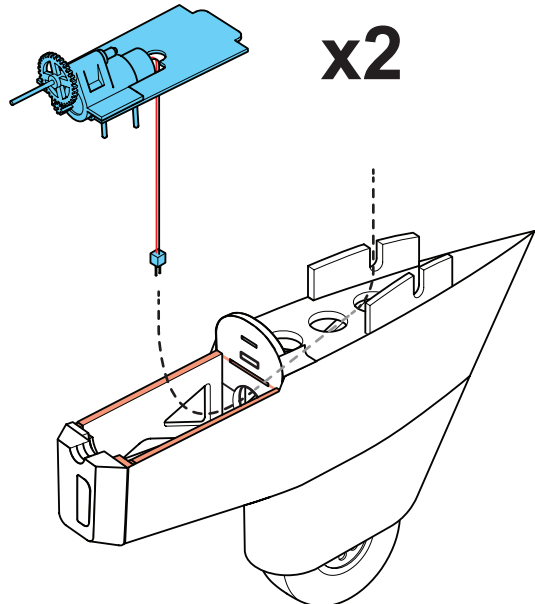
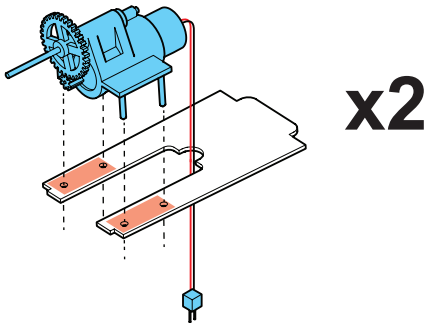

i Also fit Nacelle to starboard side

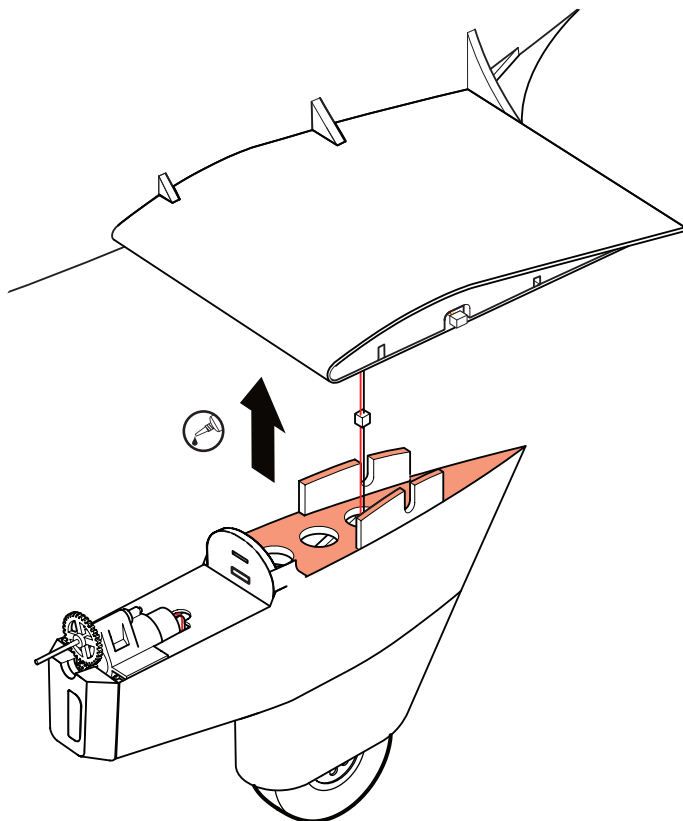

STAGE 3 WINGS



See Important Information on gluing Tyvek before proceeding

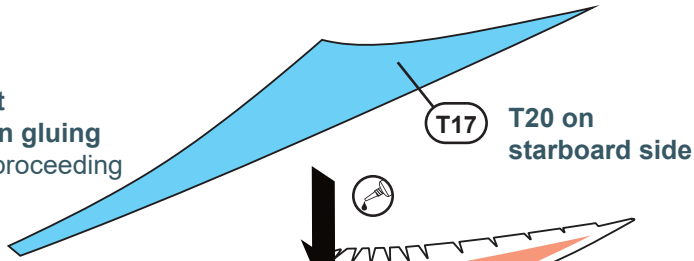

Underside of part

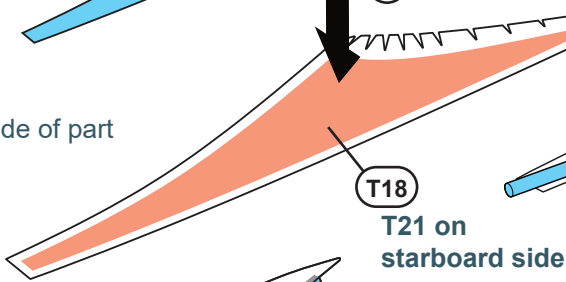

See Important Information on gluing Tyvek before proceeding

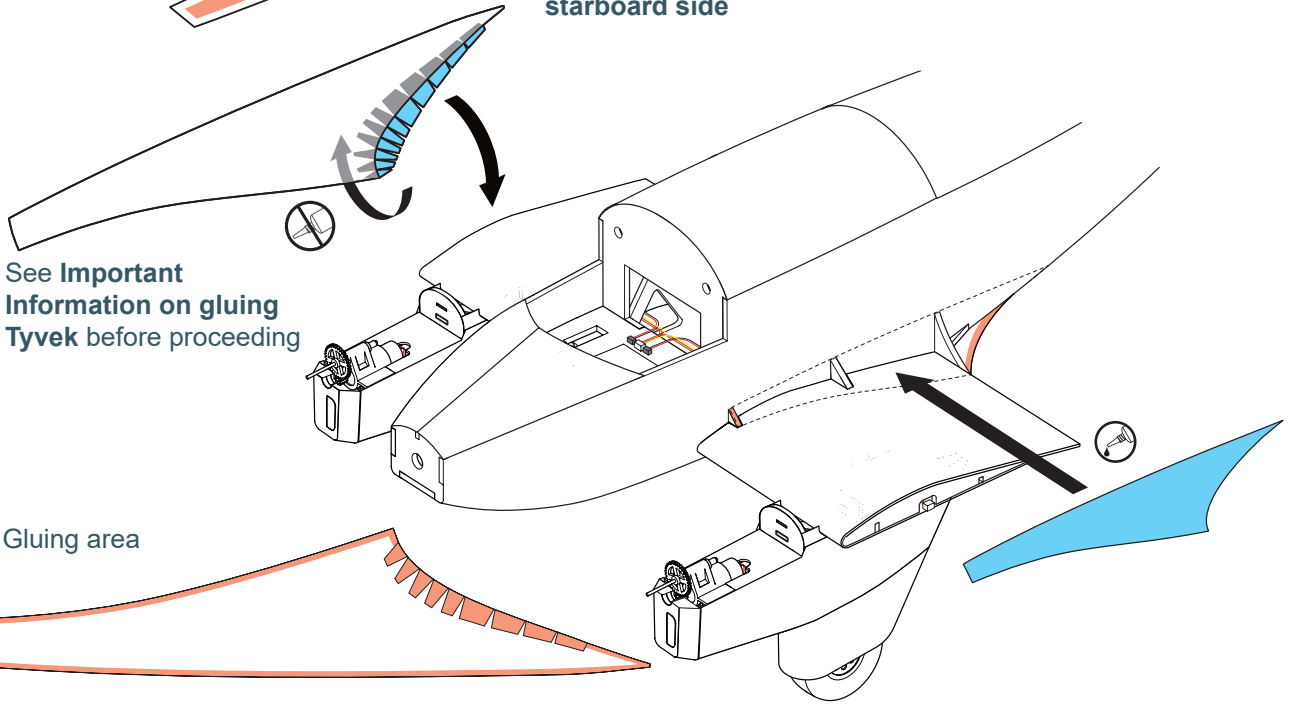

Gluing area



See Important Information on gluing Tyvek before proceeding

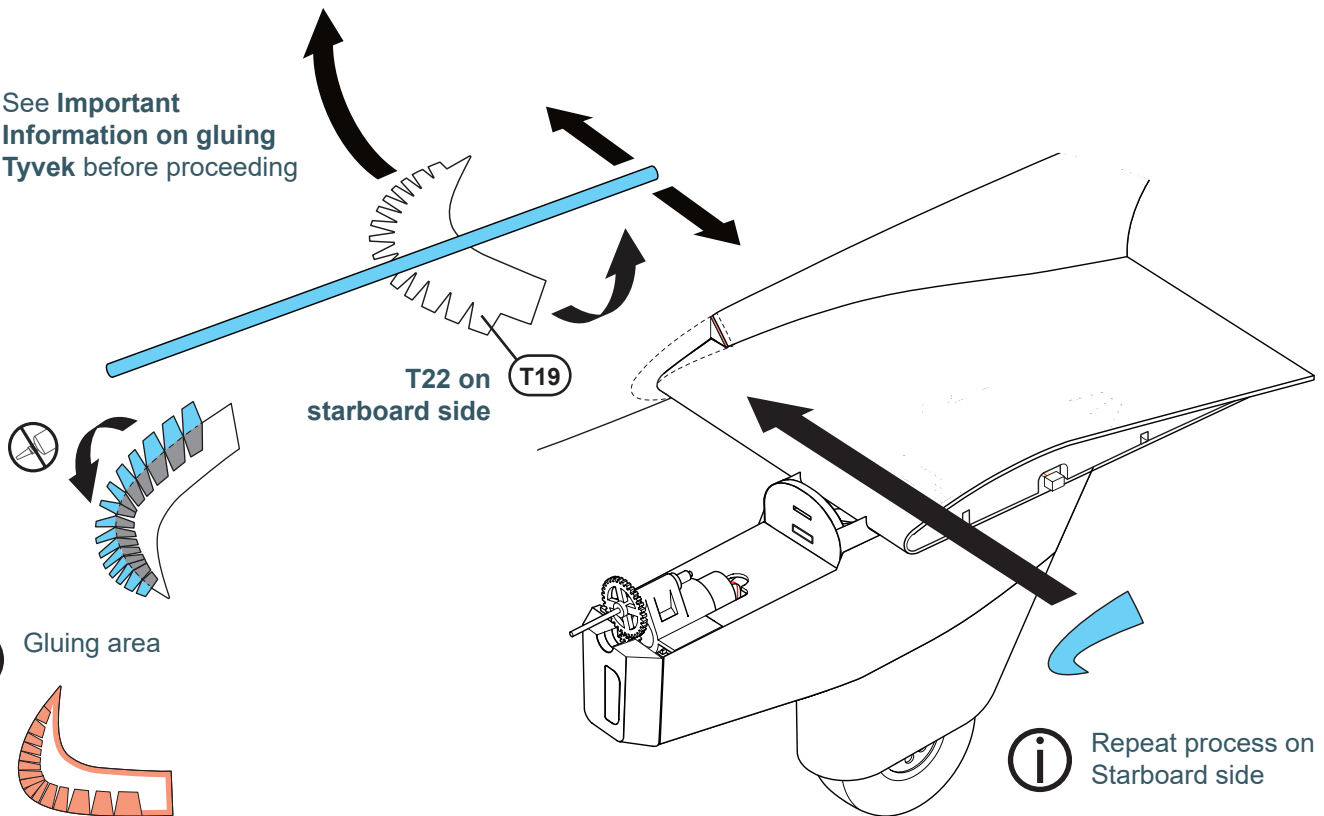

Gluing area



Repeat process on Starboard side

STAGE 3 WINGS



See Important Information on gluing Tyvek before proceeding

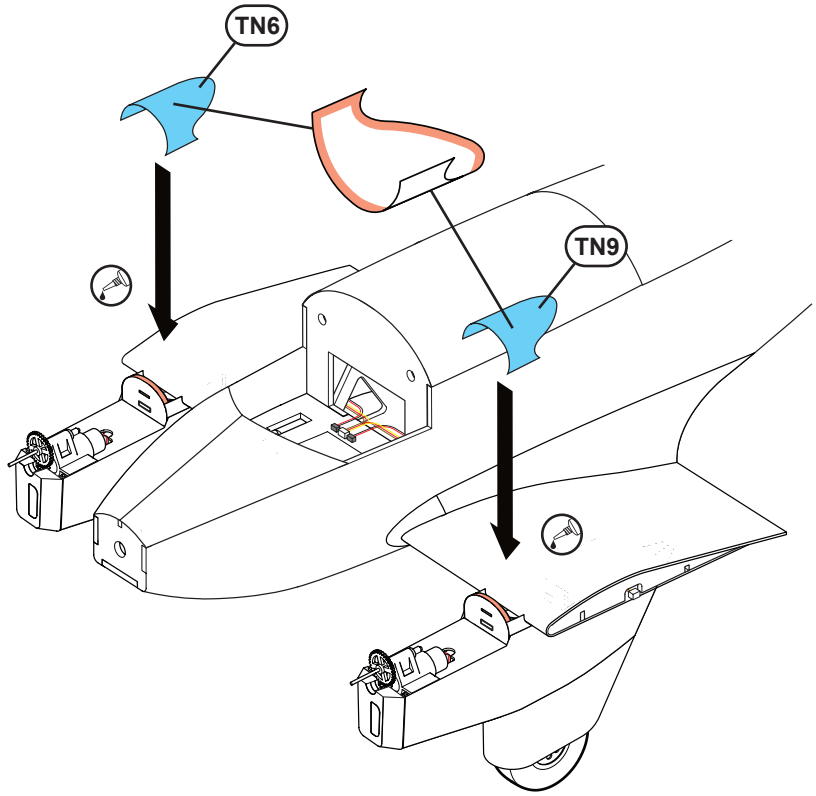
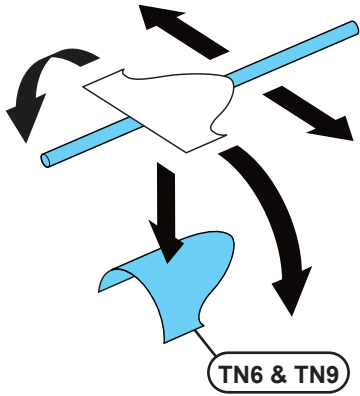

STAGE 4 TAIL



Bevel before installation - See Scoring & Beveling guide #2

Carbon Fibre
165mm x 3.0mm x 0.4mm

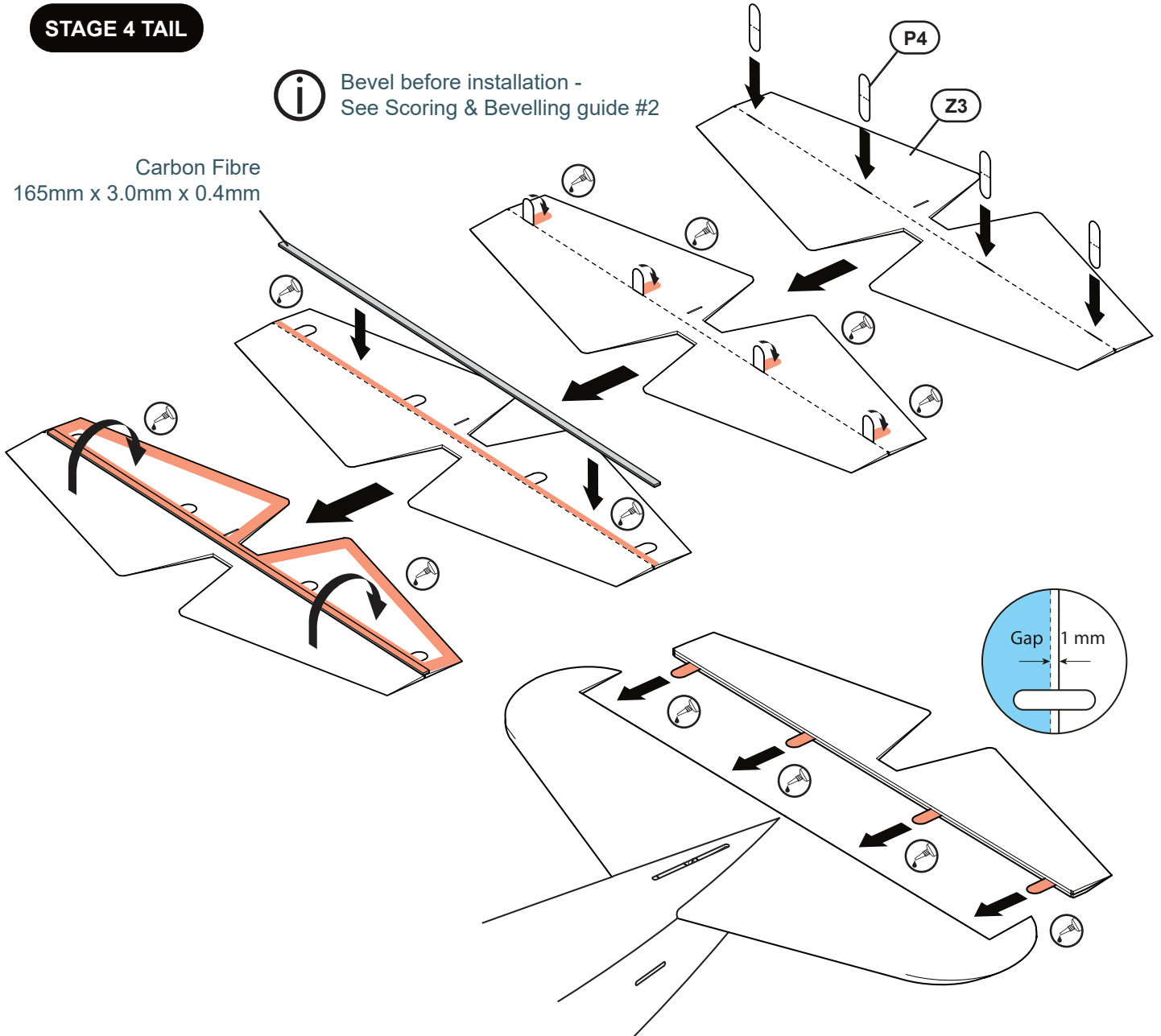

STAGE 4 TAIL

i Score & Bevel before installation -
See Scoring & Beveling guide #3

! See **Important Information on gluing Tyvek** before proceeding

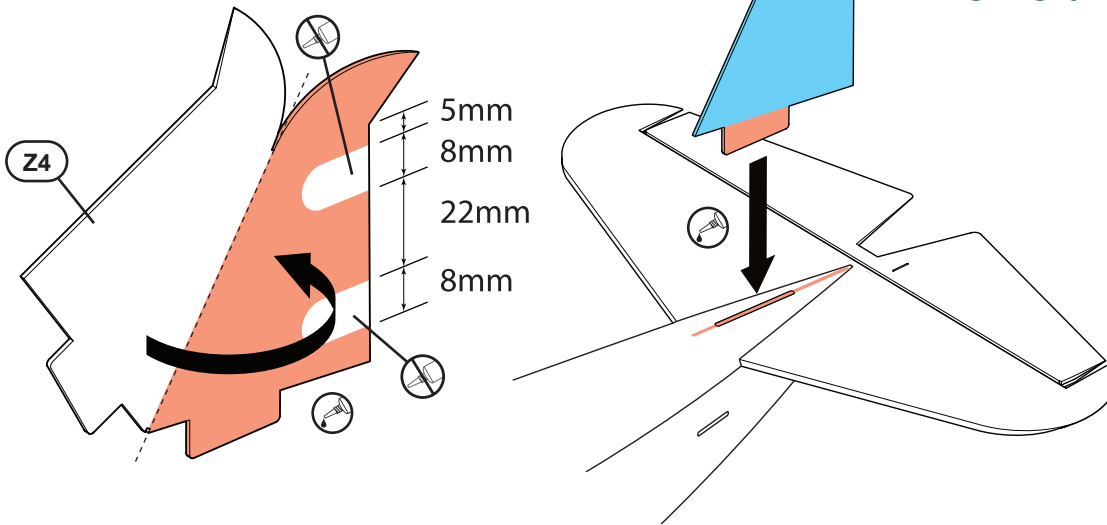

i Score & Bevel before installation -
See Scoring & Beveling guide #3

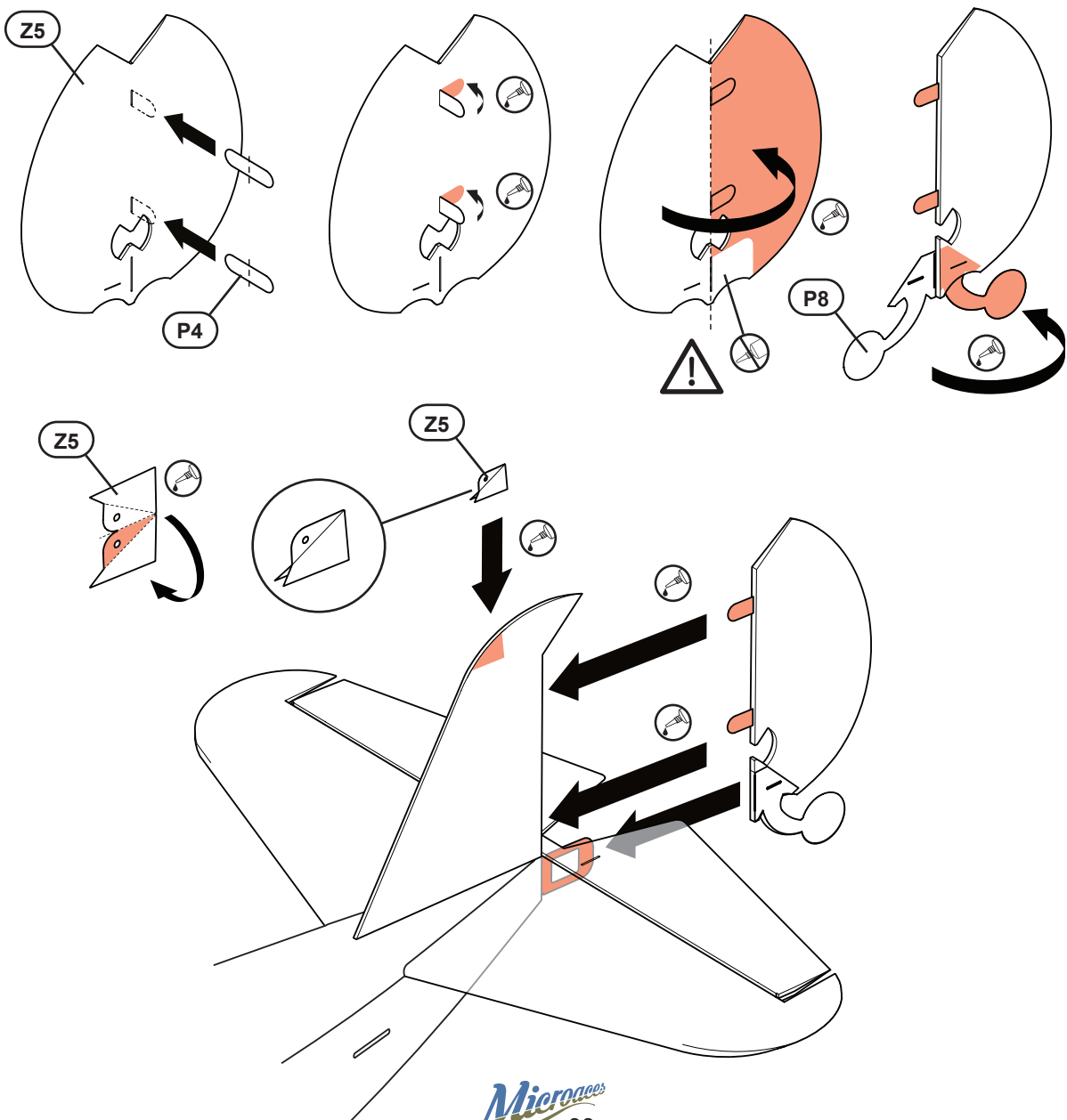

STAGE 5 HATCH

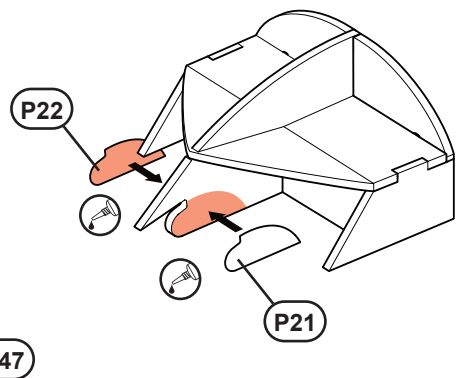
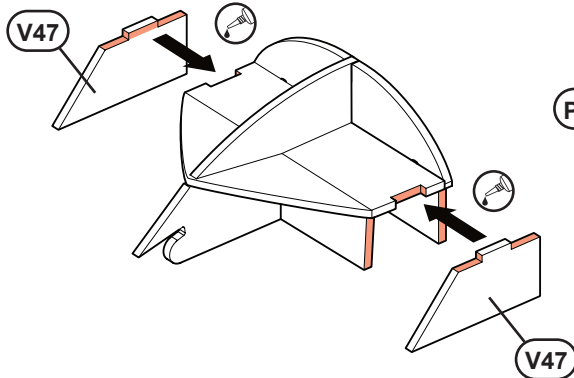
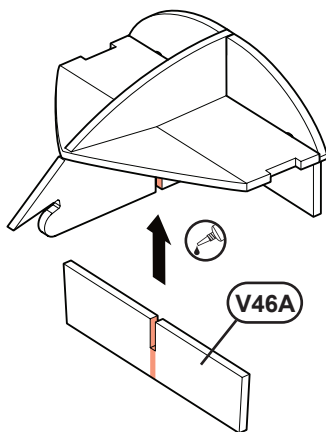
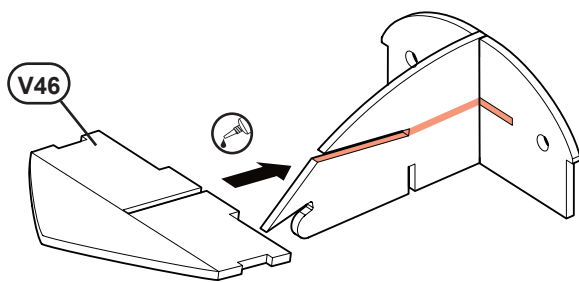
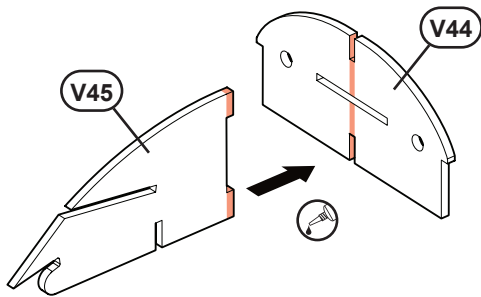

See Important Information on gluing Tyvek before proceeding



----- Fold Lines

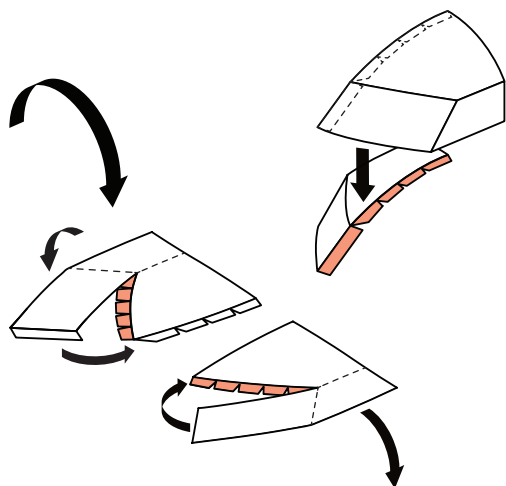
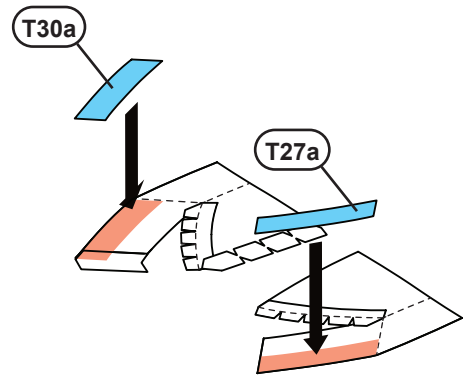
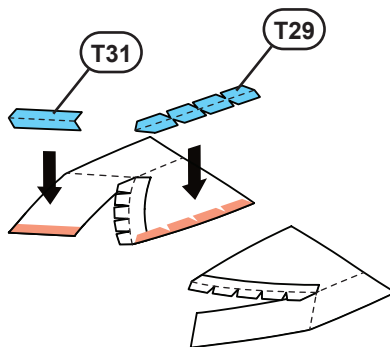
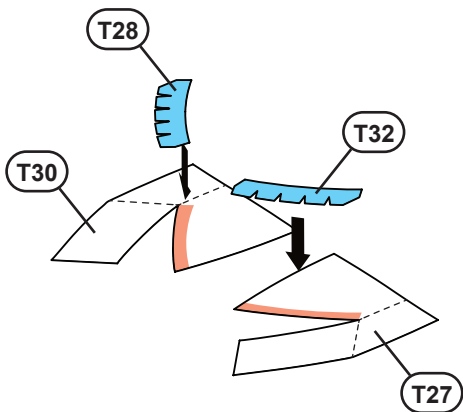

Ensure the magnets are correctly oriented before installation. Do this by matching them to the magnets installed in the chin before installing it here.

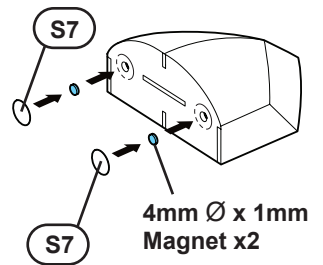

4mm Ø x 1mm Magnet x2

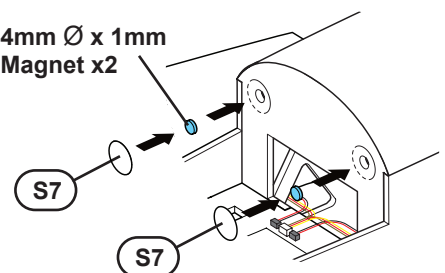

STAGE 6 WINGS

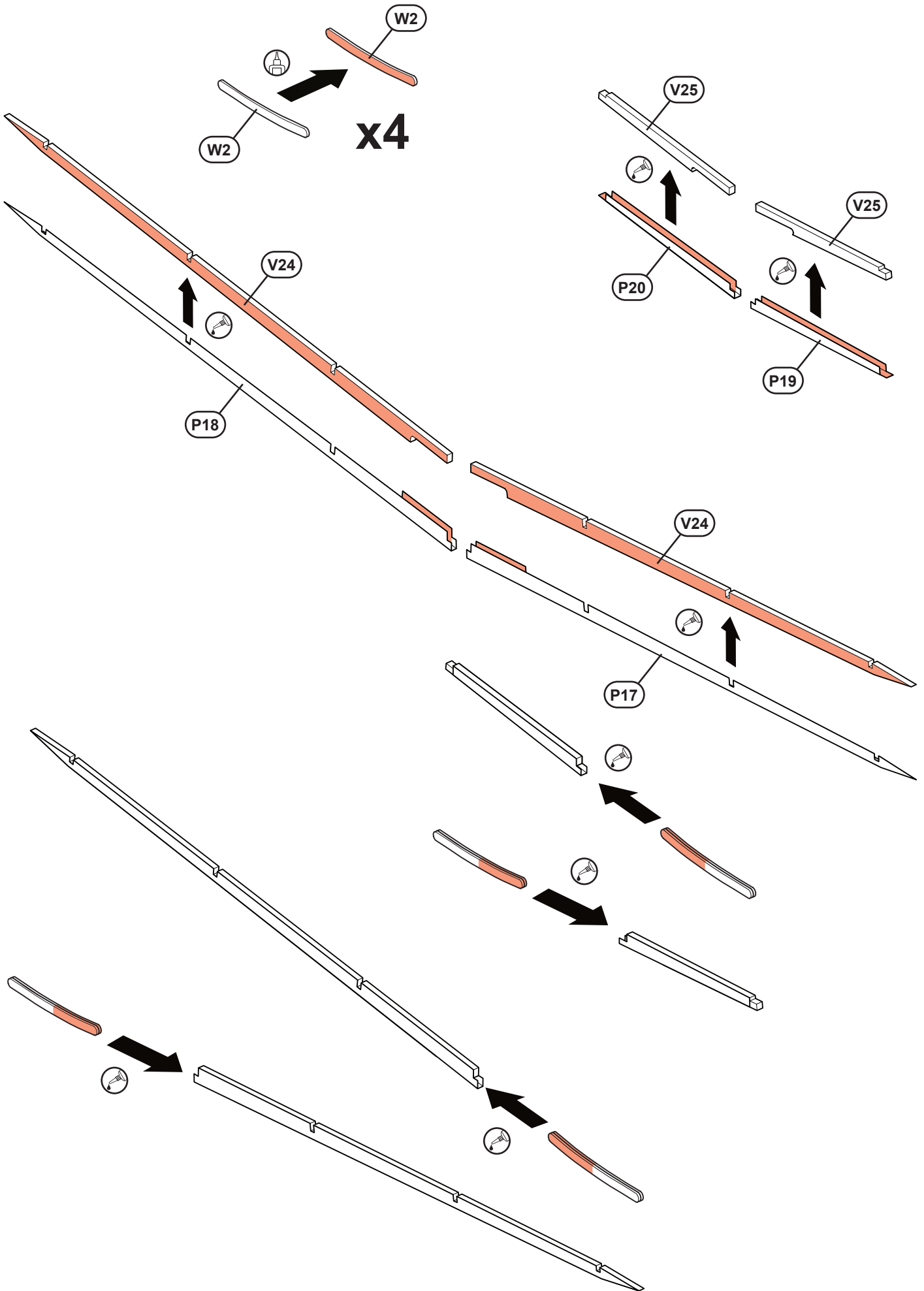

STAGE 6 WINGS

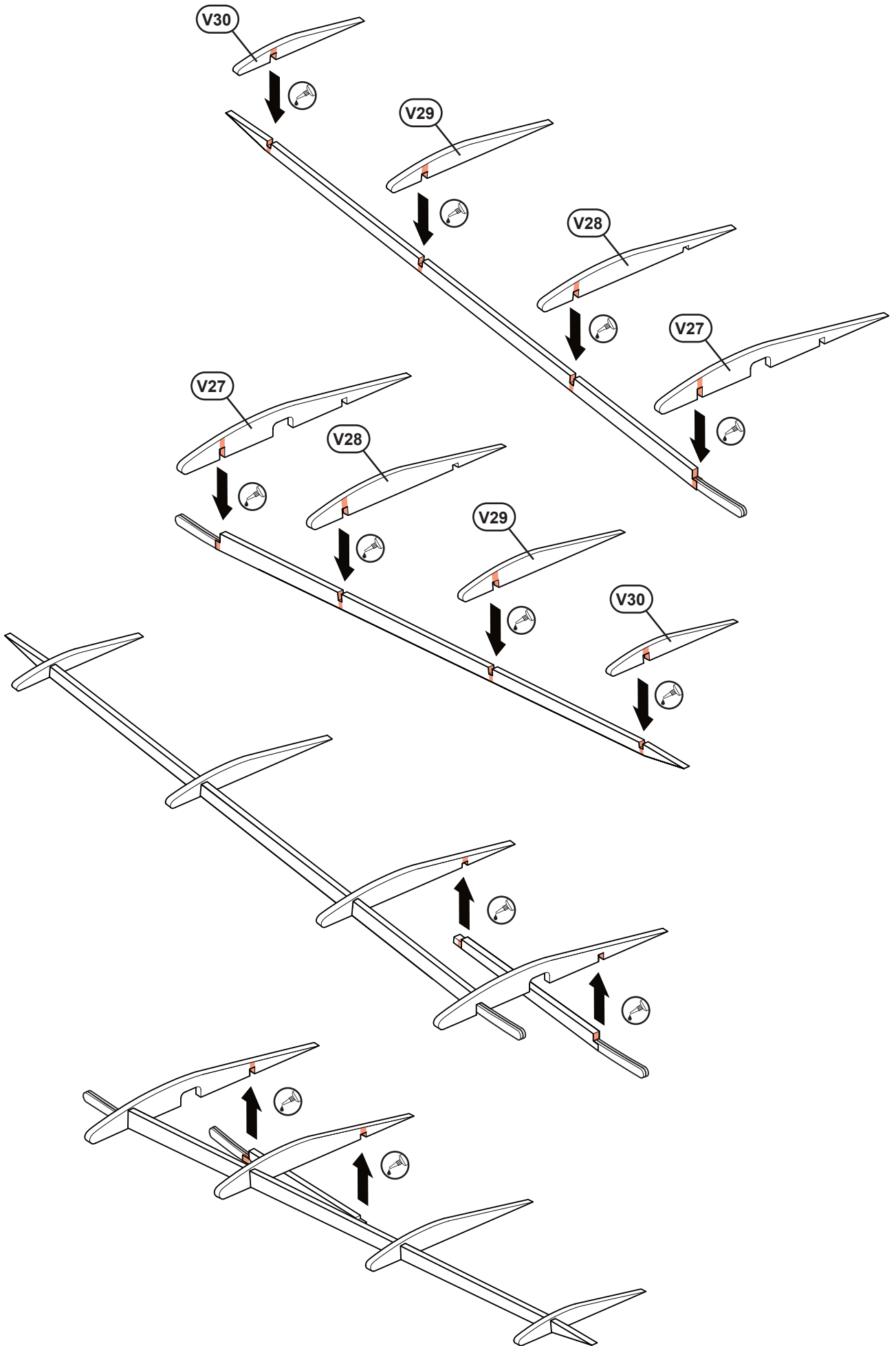

STAGE 6 WINGS

— Remove if installing aileron controls to kit

i Score & Bevel before installation - See Scoring & Bevelling guide #1

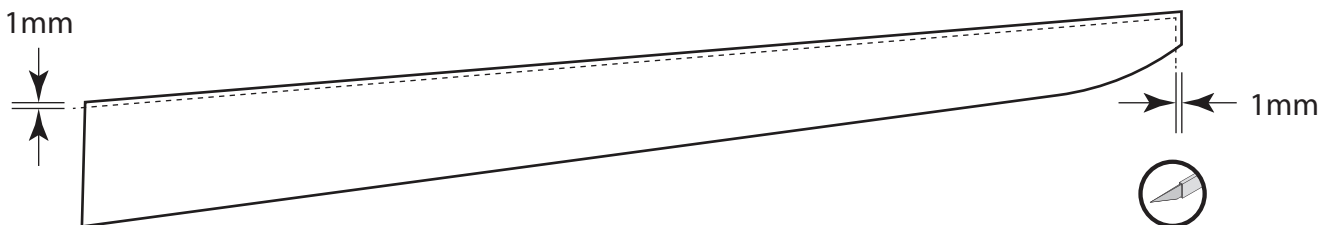
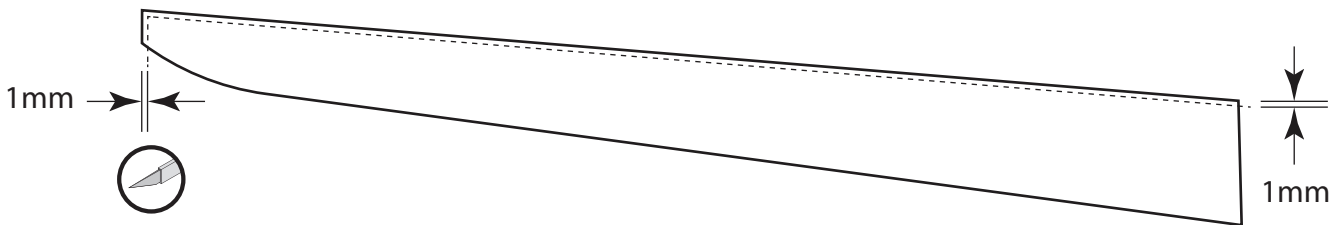
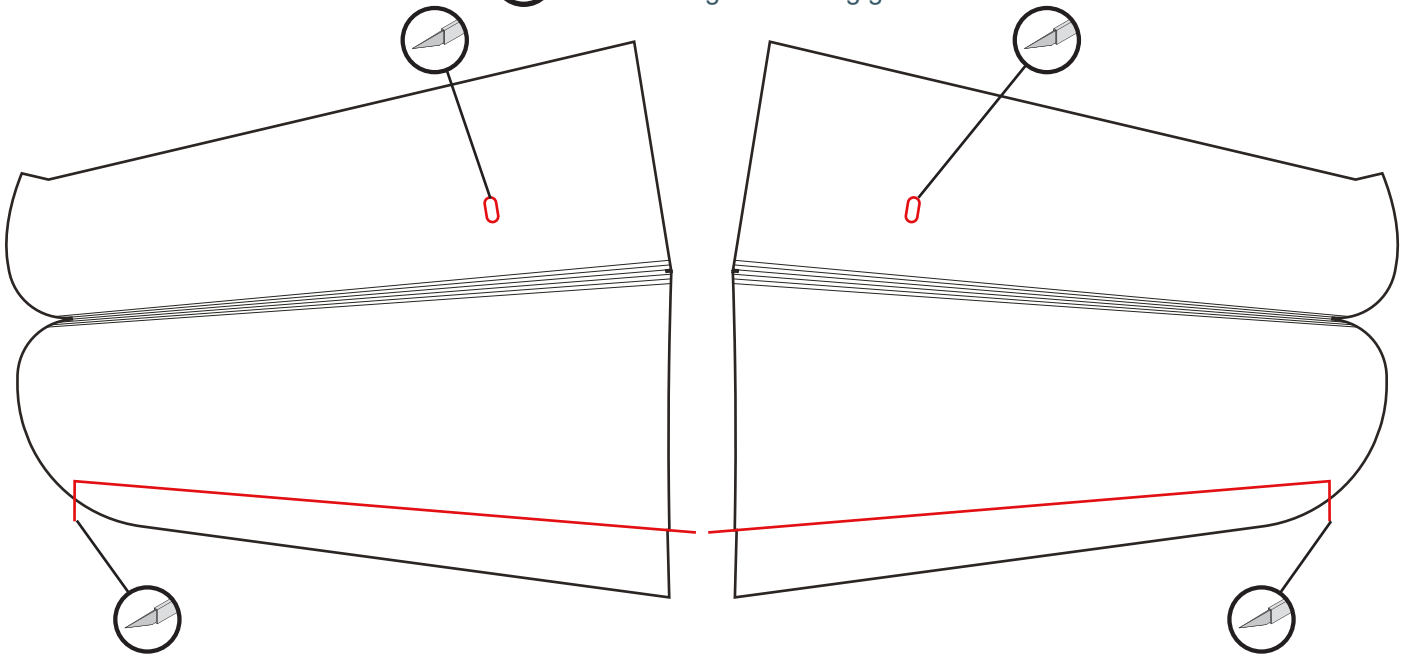

! See Important Information on gluing Tyvek before proceeding

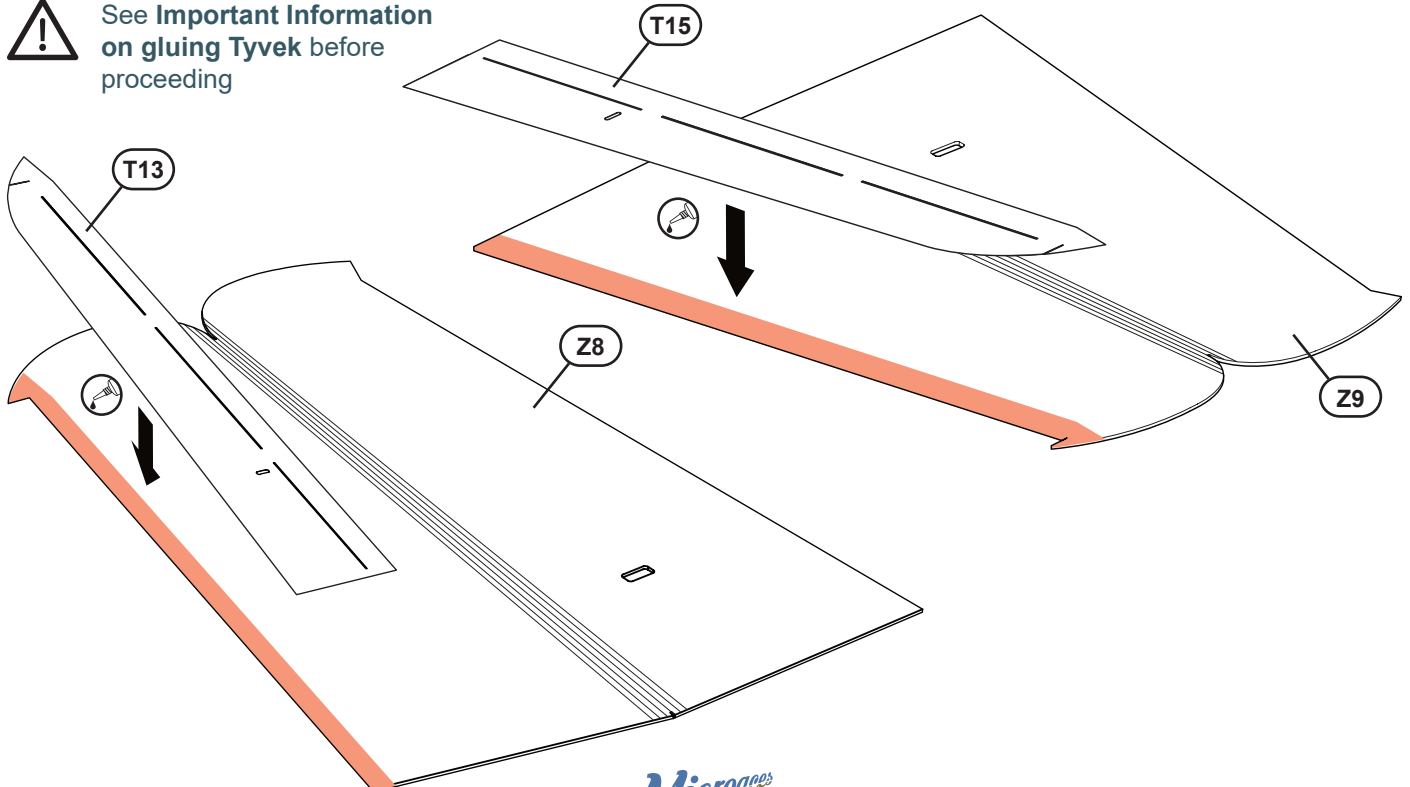

STAGE 6 WINGS



See Important Information on gluing Tyvek before proceeding

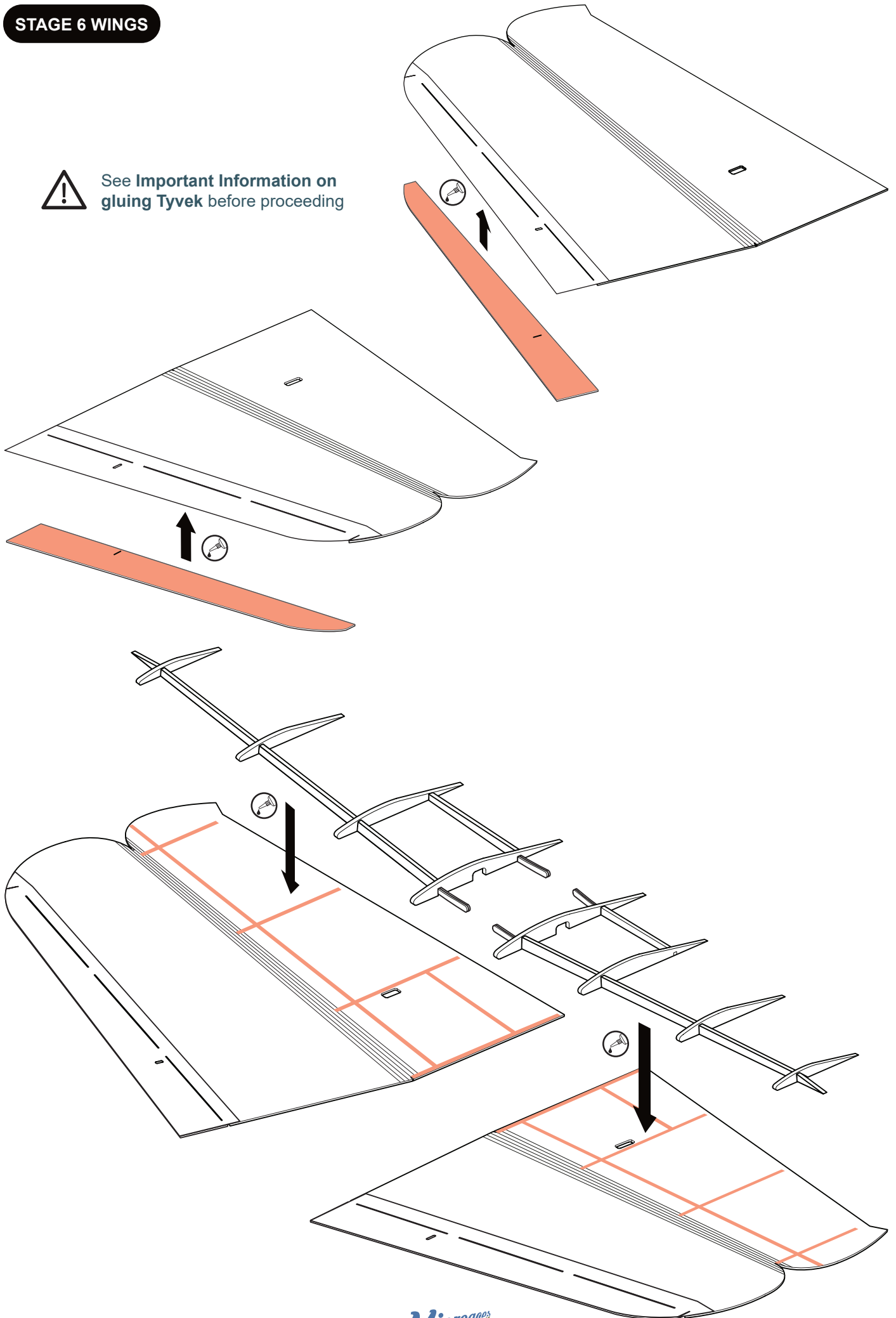

STAGE 6 WINGS



Ensure servos are centred before installation. Do this by connecting to the bound receiver and ensuring the trim on the transmitter is neutral

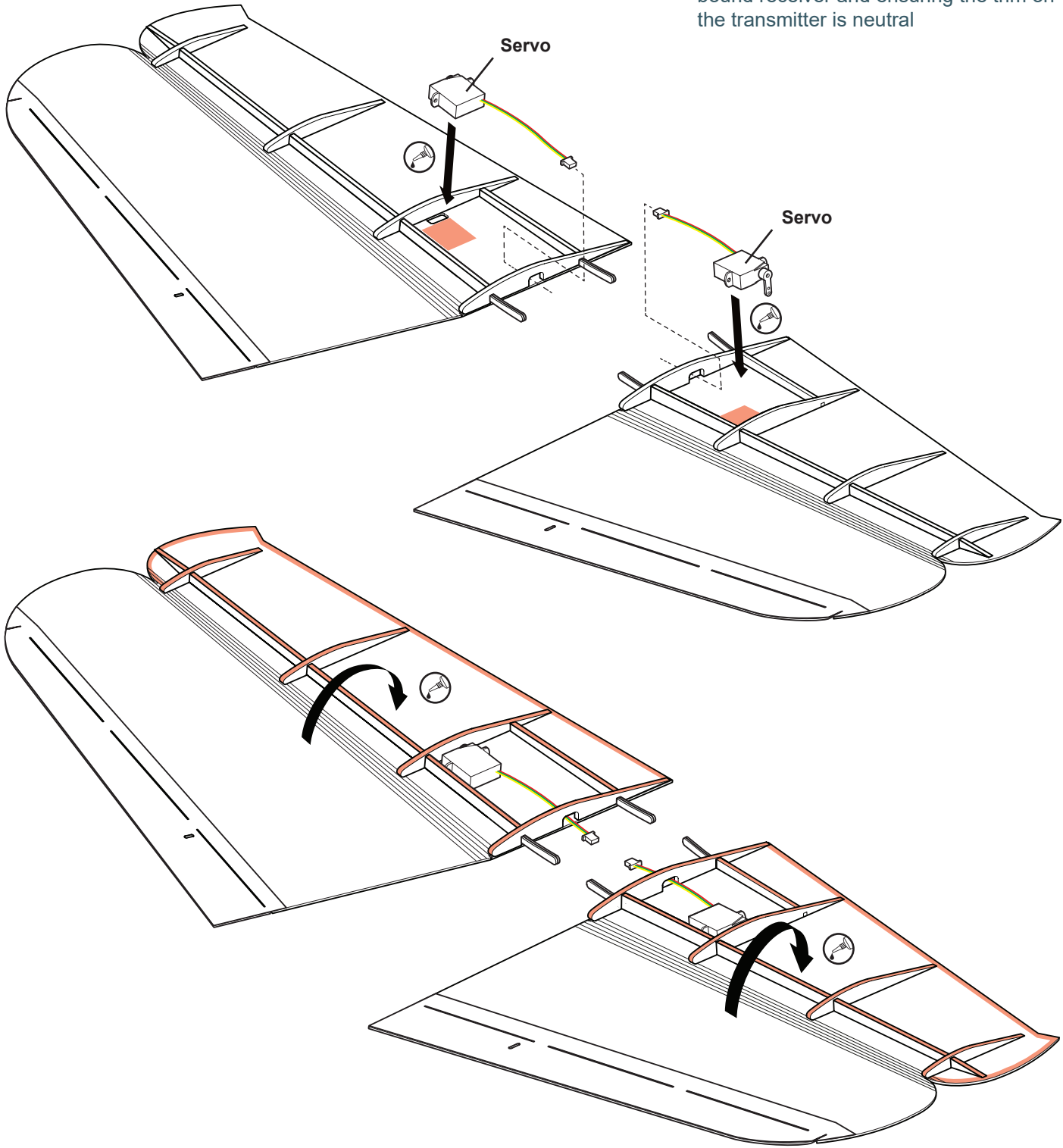

STAGE 6 WINGS

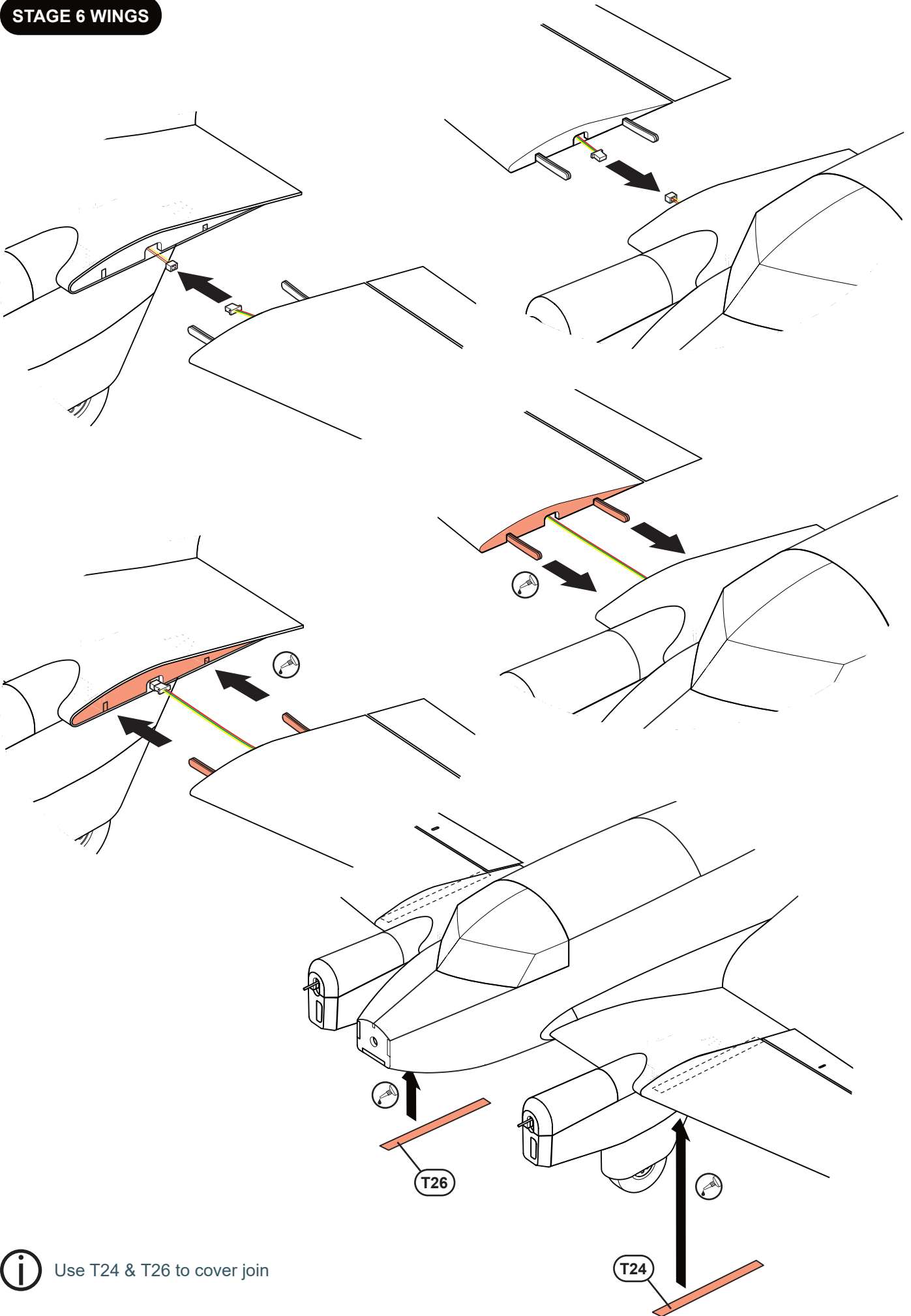



i Use T24 & T26 to cover join

STAGE 6 WINGS

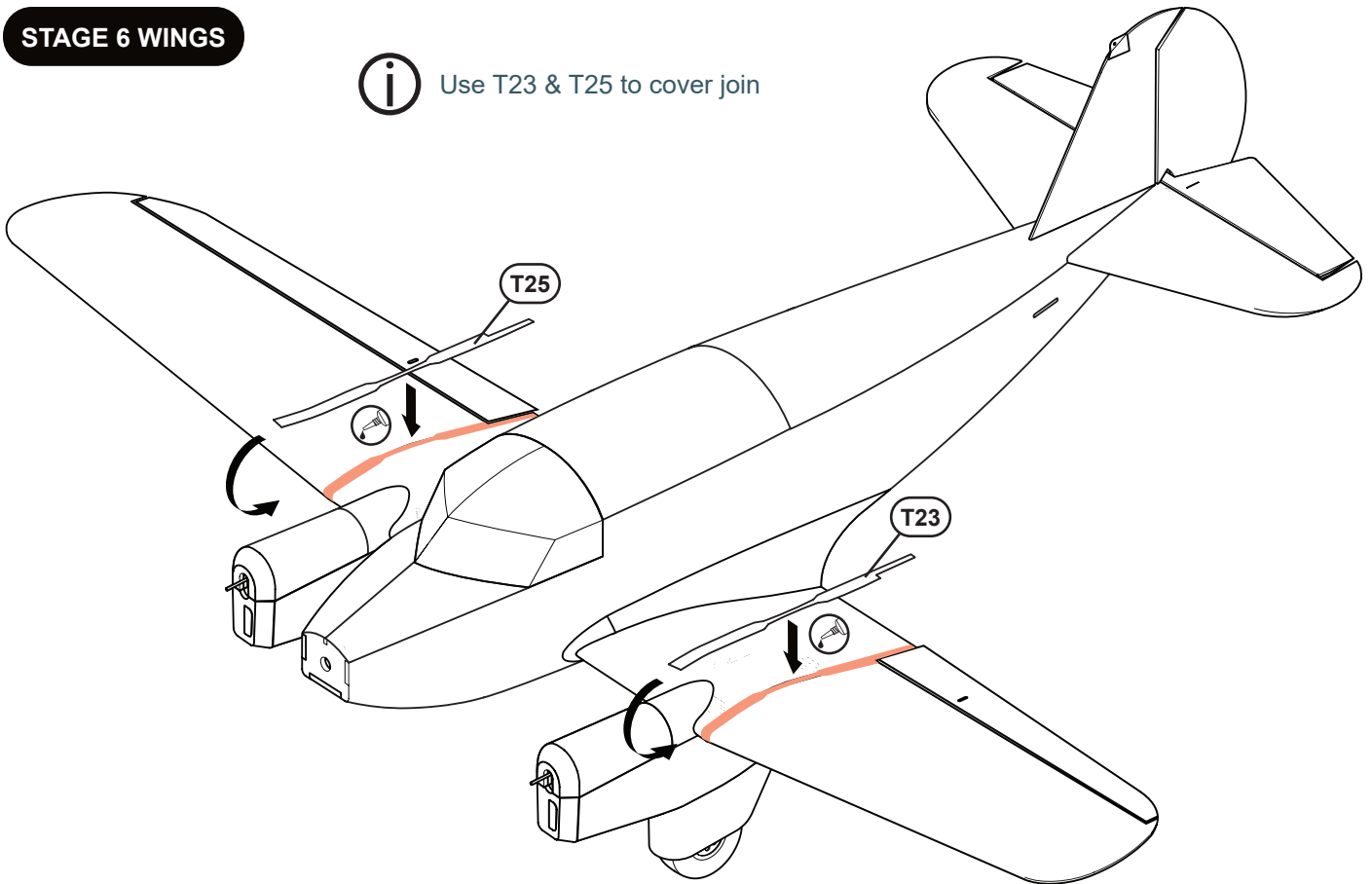
 Use T23 & T25 to cover join



 Fit servos before installing servo arms to make control rod attachment easier

 Ensure servos are centred before installation. Do this by connecting to the bound receiver and ensuring the trim on the transmitter is neutral

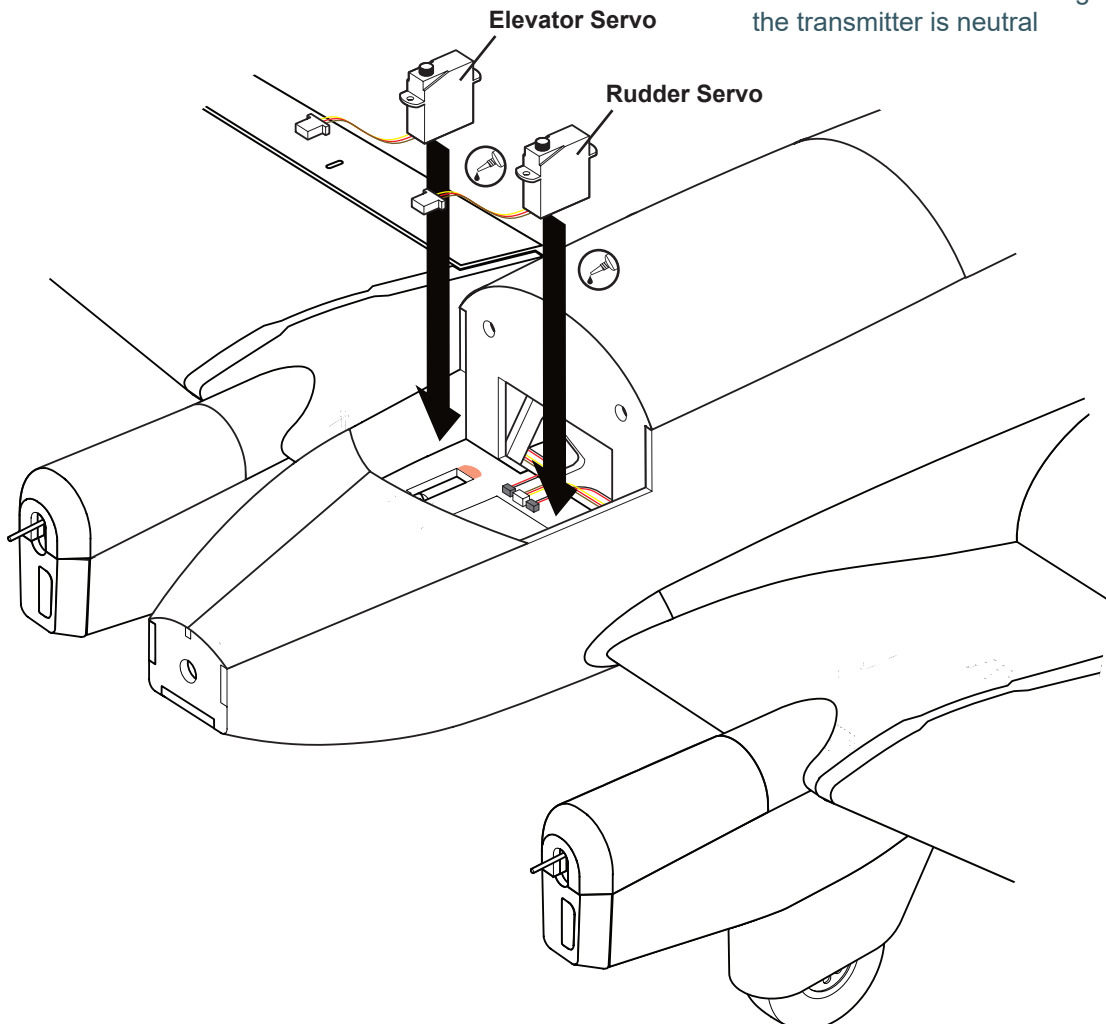

STAGE 7 CONTROL HORNS

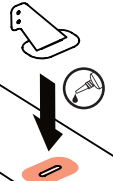
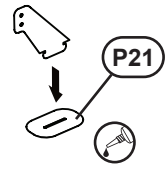
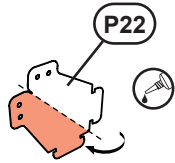
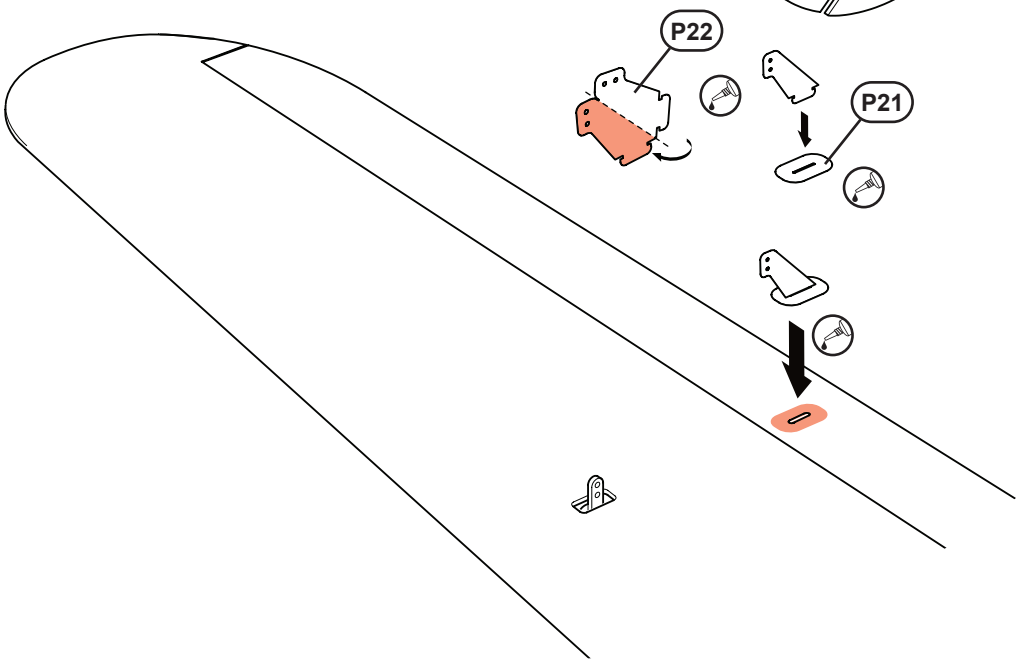
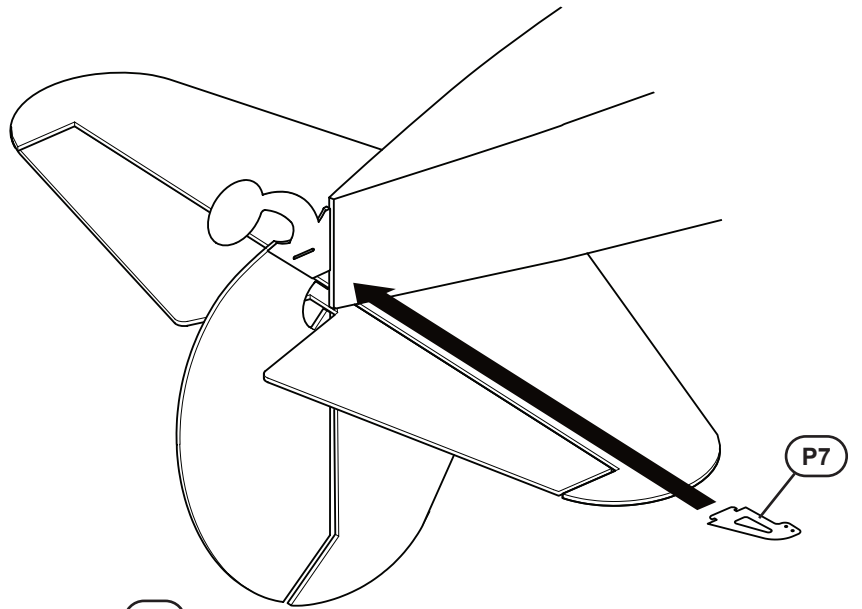
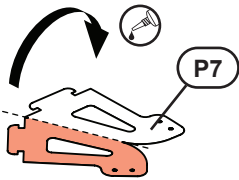
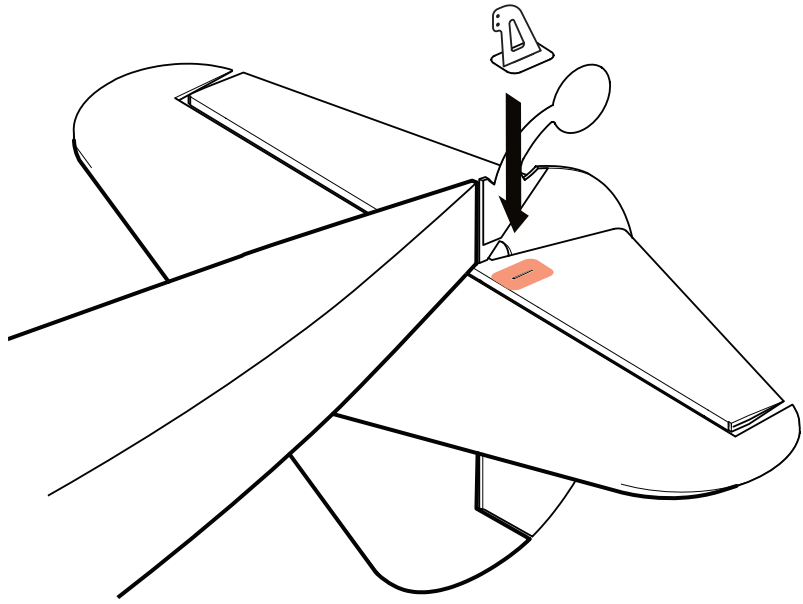
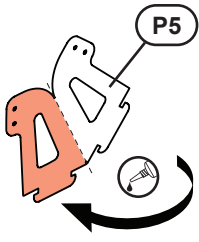

x2

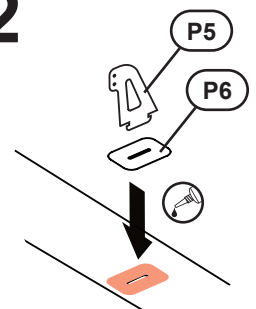

STAGE 7 CONTROL RODS

i Create wireforms from the 4 supplied piano wire control rods using pliers & wire cutters

Elevator

Rudder

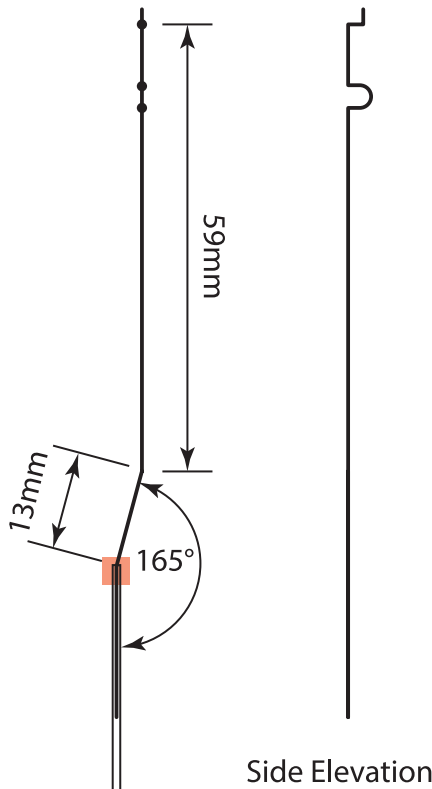
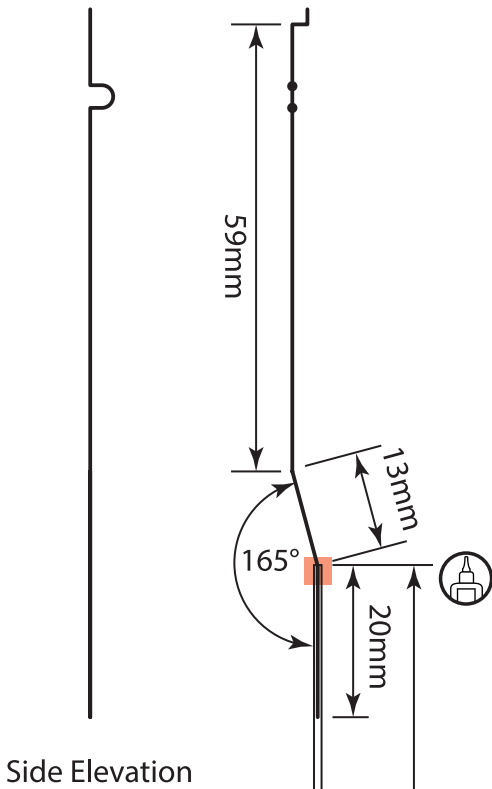

1mm Ø
Carbon Fibre Tube
220mm long

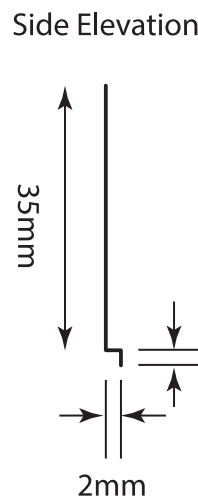
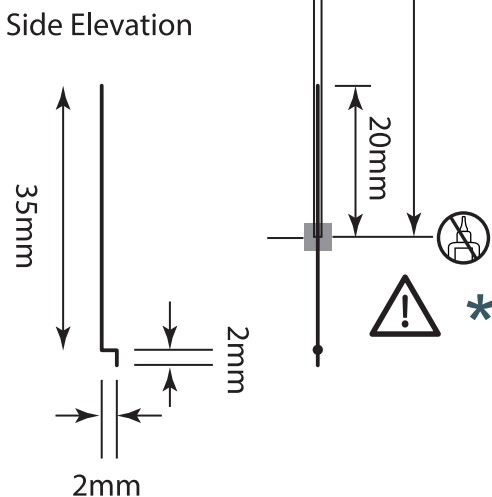
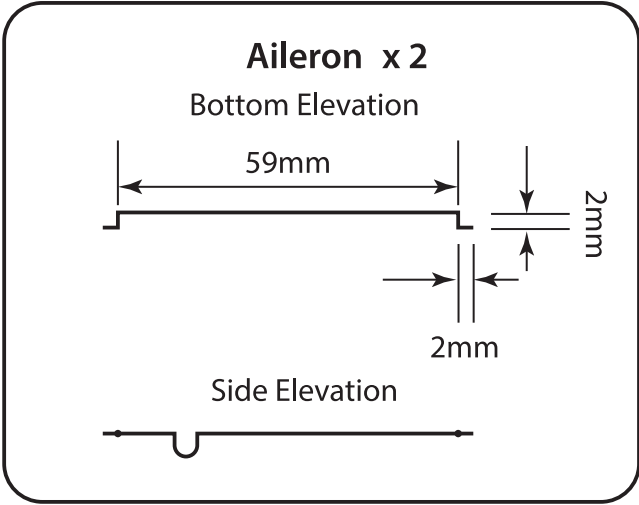

* Only glue in place once installed and tested

STAGE 7 CONTROL RODS

Top View

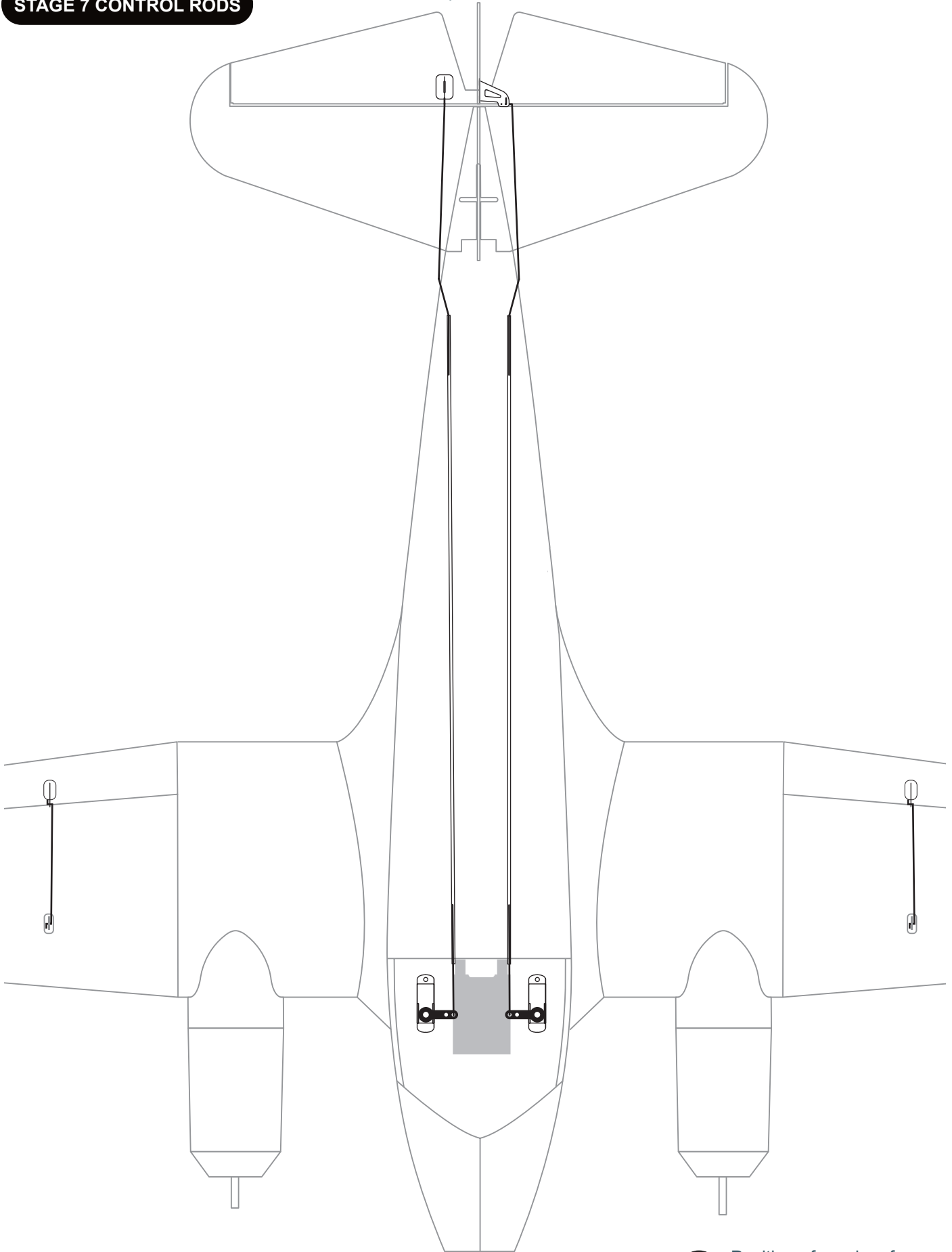

Position of receiver for installation use double sided servo tape

STAGE 8 ELECTRONICS

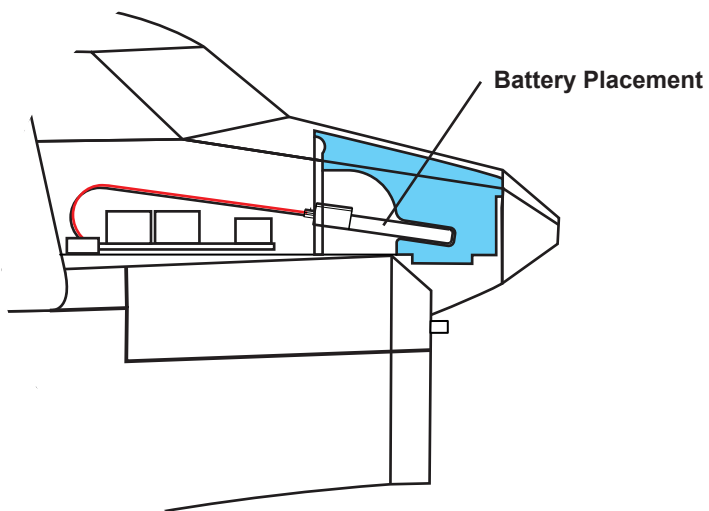
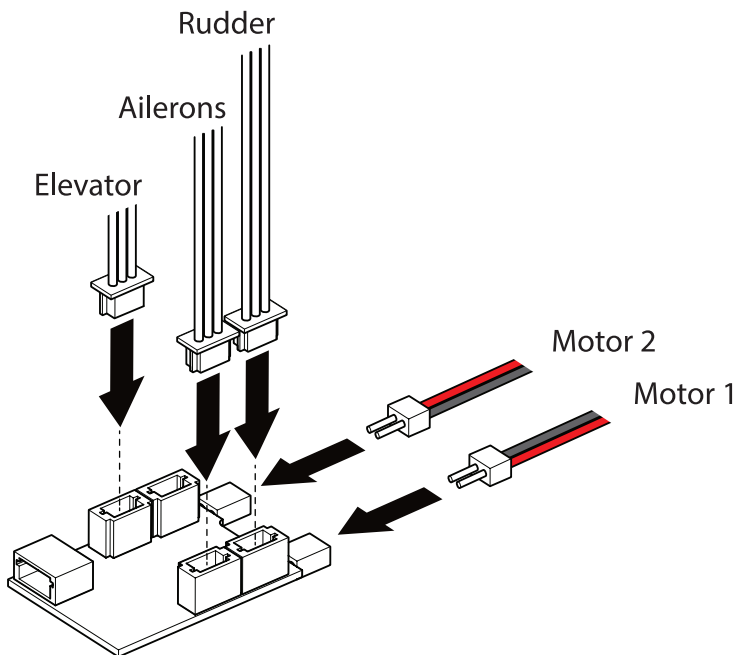

STAGE 9 NOSE ASSEMBLY

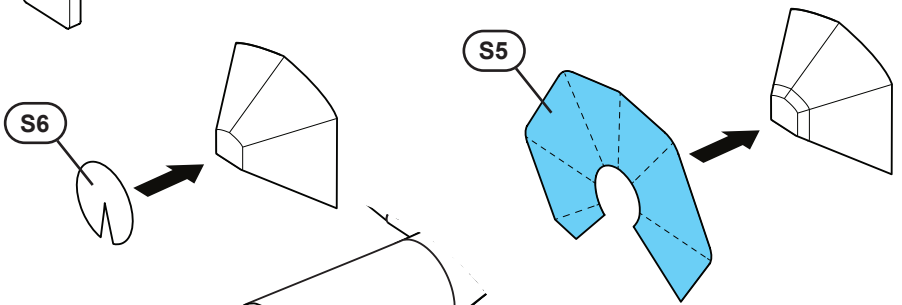
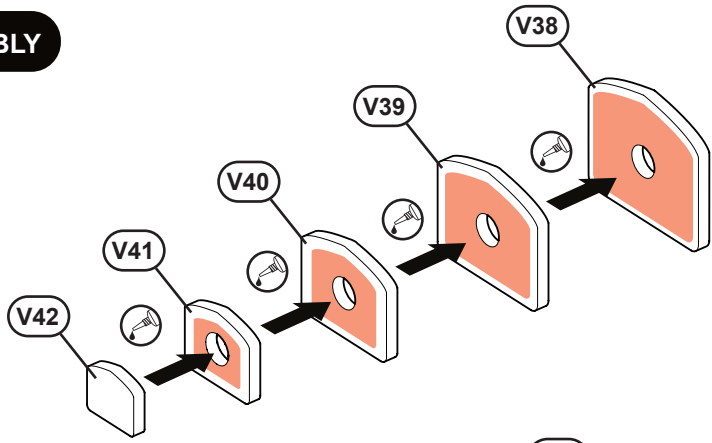

i 2mm foam can be readily carved with a fresh, sharp blade for quick results

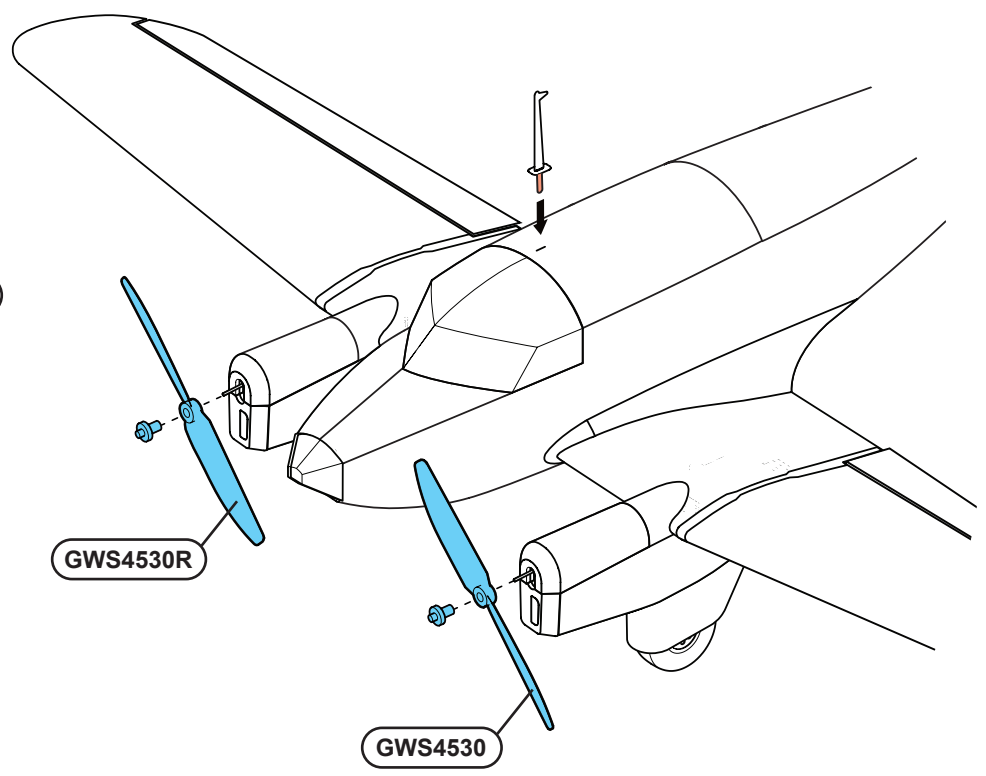
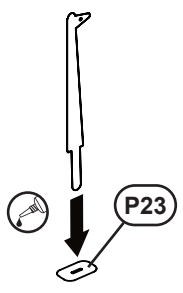
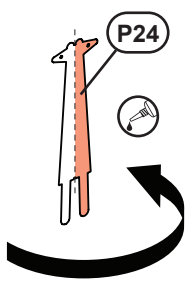
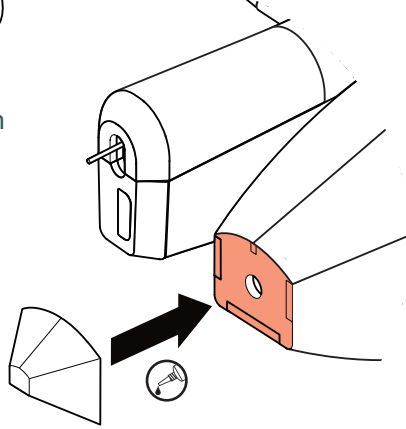

STAGE 10 DETAILS

Centre of Gravity (CoG)

With all the electronics installed including the battery, the CoG should be around the apex of the top wing as shown on the diagram below.

Balance on finger tips to see if the aircraft balances at this point. Before adding any weight it is advisable to perform a glide test. Add weight accordingly to obtain a smooth glide.

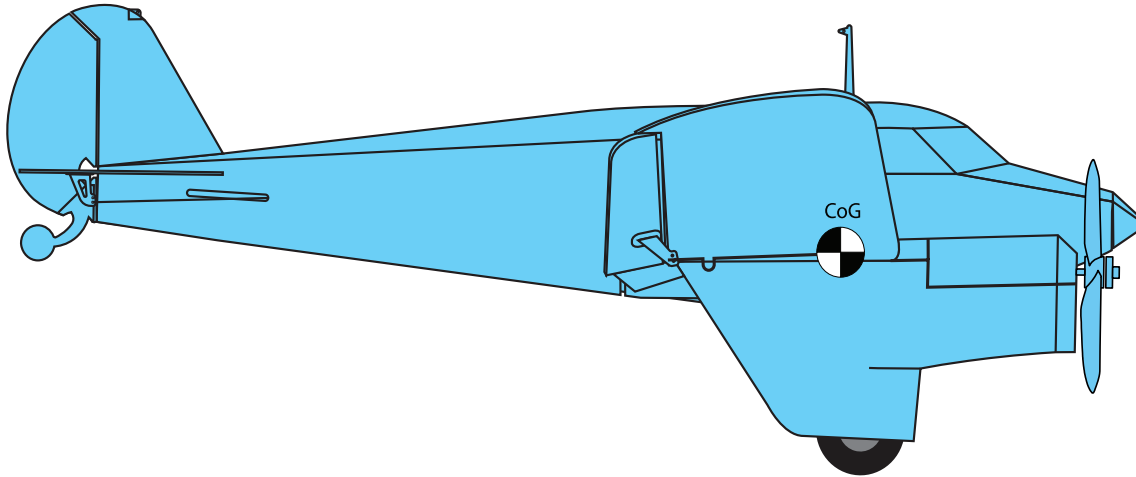

Glide Test - How to!

Find a suitable test space with a forgiving landing area, e.g. over long grass or onto soft furnishing. Ensure all control surfaces are in the neutral position. Gently toss the model straight and level. Observe the results and add balancing weight if required.

*Tail Heavy
Add weight to Nose!*

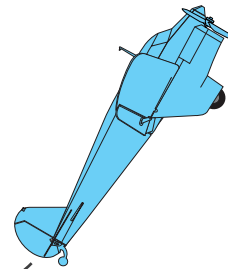

Spot On!

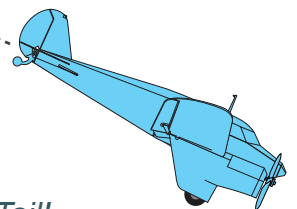

Radio Control Recommendations

If the recommended electronics have been supplied by Microaces, the receiver will have been set up to operate with the Percee model. But please check before flying to ensure flight surfaces are operating in the required direction and reverse any that aren't, on your transmitter* if required.

To enable switching between SR3X stabilization modes, set up CH5 to operate from one of the transmitter's 3 way switches*.

For initial flight tests, a modest amount of exponential* is advised on aileron, elevator and rudder.

*Nose Heavy
Add weight to Tail!*

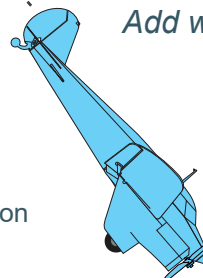

This can be altered as you establish the flight characteristics of your model.

*Consult your transmitter's user manual.