

Microaces

ASSEMBLY GUIDE

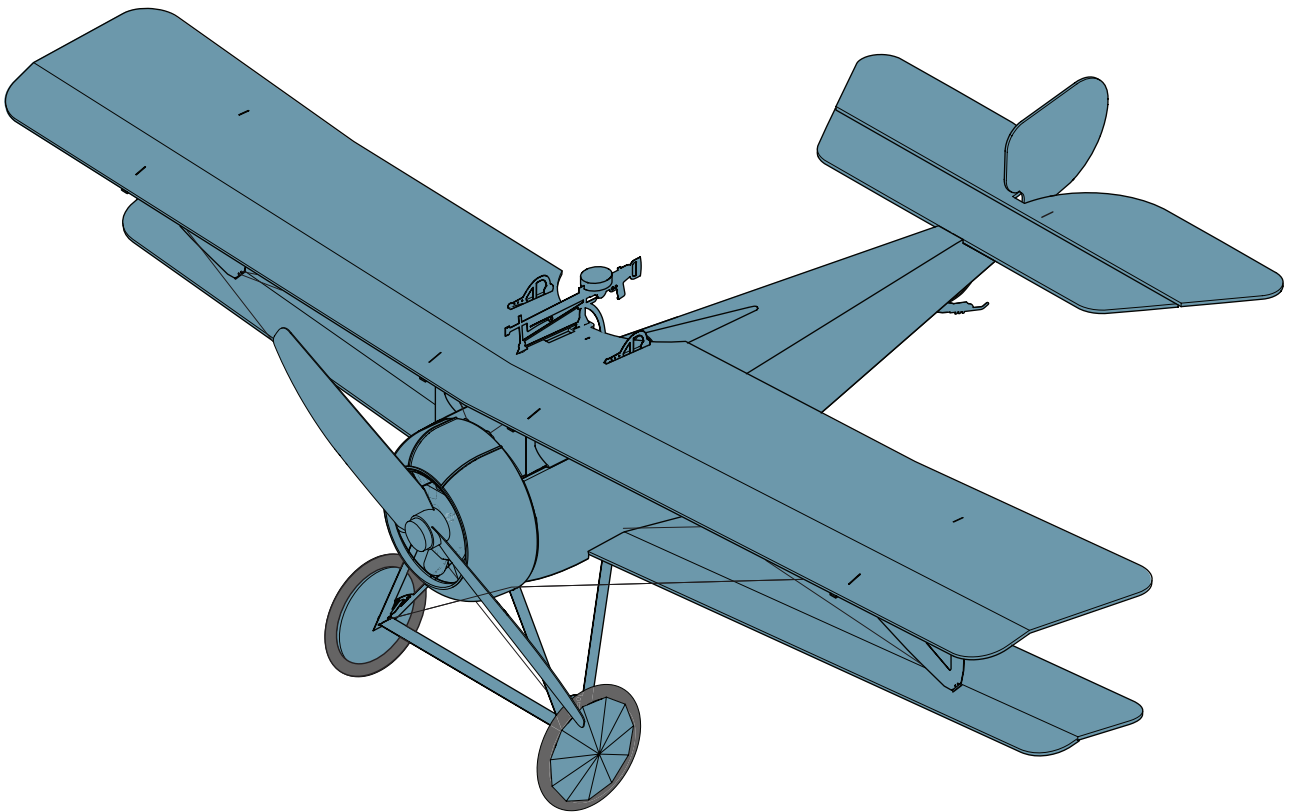

Nieuport 17



Scan for Video Guide

Version 2.2



Introduction

Thank you for purchasing this Microaces Aero Kit. Designed using innovative ideas, advanced materials and detailed aircraft illustrations, this 1/24th scale aircraft will bring you hours of building enjoyment and many more exciting flying hours too. Please take your time to familiarise yourself with these instructions as the aircraft assembles in a very unique way, following a sequence of steps that should be adhered too to ensure a satisfactory and flyable model.

Safety

It is extremely important to us that you and those around you remain safe while building and flying Microaces kits. Please take note of the following notices of safety. Microaces Aero kits contain parts and packaging **unsuitable** for handling by small children. Please ensure that children under the age of 6 years are prevented from handling the component parts or packaging of this kit. Although the resulting model is lightweight, we DON'T recommend that you fly it near or over others where there is a danger of striking someone. We DO recommend that the maiden flight is performed over long grass in calm weather away from others.

Assembly











Read all the instructions carefully before starting assembly.

It is important to use the recommended glues or an equivalent with similar properties. Foam parts must be glued with a foam safe cement or permanent damage can result to components. Ensure your knife has a fresh or sharp blade installed to ensure a clean cut.

Warranty

Microaces warrants this kit is supplied with all components present and that those components are free from cosmetic or structural damage to an extent that would impair the assembly of the kit, alter the aesthetics of the built model and/or the flight performance of the resulting model. If any parts are missing or damaged please contact us via email at: support@microaces.com

Key

	Note (Information)		Attention
	Part Number		Do Not Glue
	Contact Adhesive (Foam Safe)		Score before assembly
	Aliphatic Resin (or Foam Safe CA)		Cut
	Paint		Sanding Required
	Area of adhesion for glue		

KIT PARTS

Sheet Parts

1 x 2mm Laser cut foam airframe
1 x 1mm printed & laser cut foam fuselage
1 x 1mm printed & laser cut foam flight surfaces
1 x 200 micron printed & laser cut polypropylene
1 x polyester sticker sheet
1 x 0.8mm laser cut plywood motor mount parts

Loose Parts

2 x neoprene tyres
1 x vac formed plastic cowl part
1 x 4mm Ø plastic tube (Black)
2 x 4mm Ø x 1mm neodymium magnets
1 x 118mm x 0.4mm x 1mm carbon fibre strip
1 x 382mm x 0.4mm x 1mm carbon fibre strip
1 x 85mm x 1mm Ø carbon fibre rod
1 x piano wire elevator control rod
1 x piano wire rudder control rod
1 x profile pilot figure
1 x Spectra rigging wire
1 x Brass tube 2mm Ø x 12mm

RECOMMENDED TOOLS/GLUES

Knife or Scalpel with fresh blade

Steel Rule or straight edge

Sanding Stick or sand paper (180 grit recommended)

Tweezers

Needle nose pliers

UHU por foam safe adhesive (For foam & plastic)

Aliphatic Resin or Foam safe cyano glue (for rigging & re-inforcement)

2mm FOAM

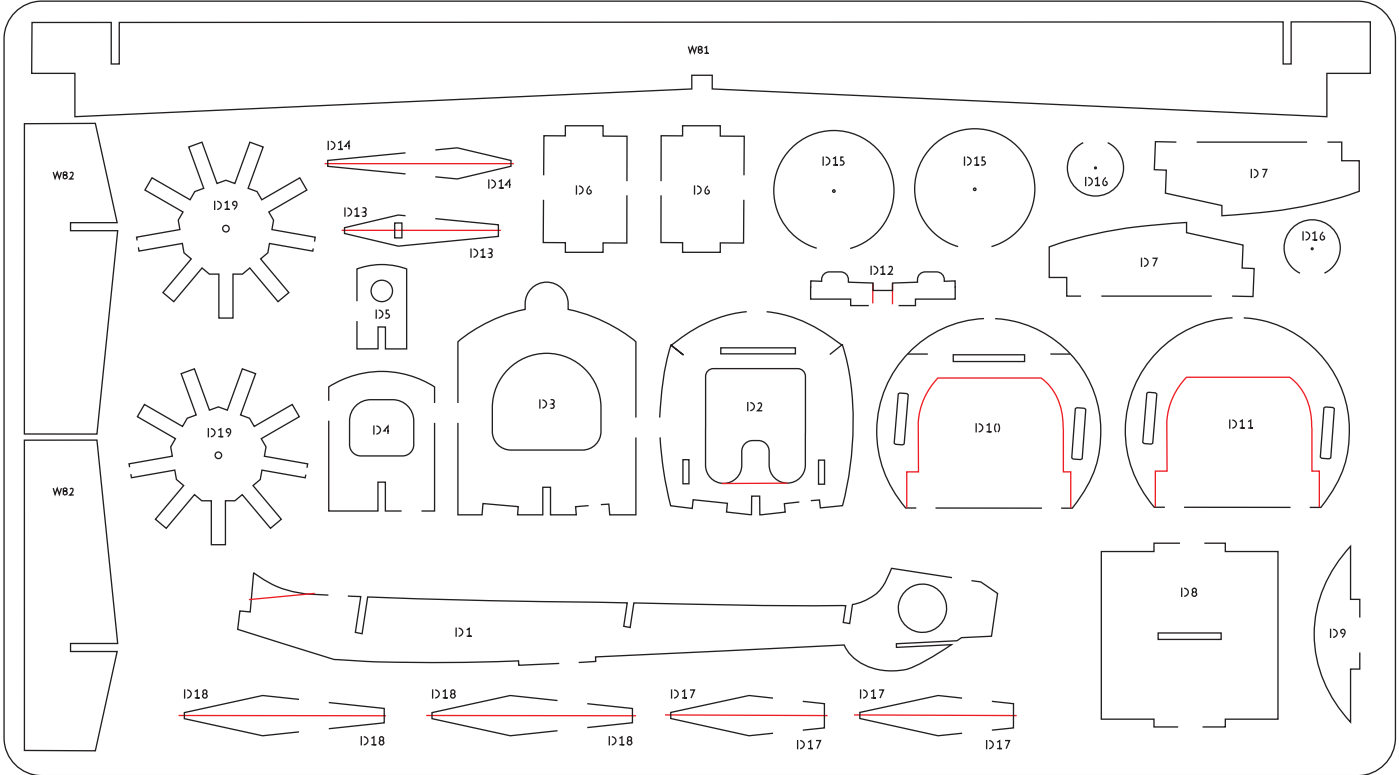

PLASTIC PARTS

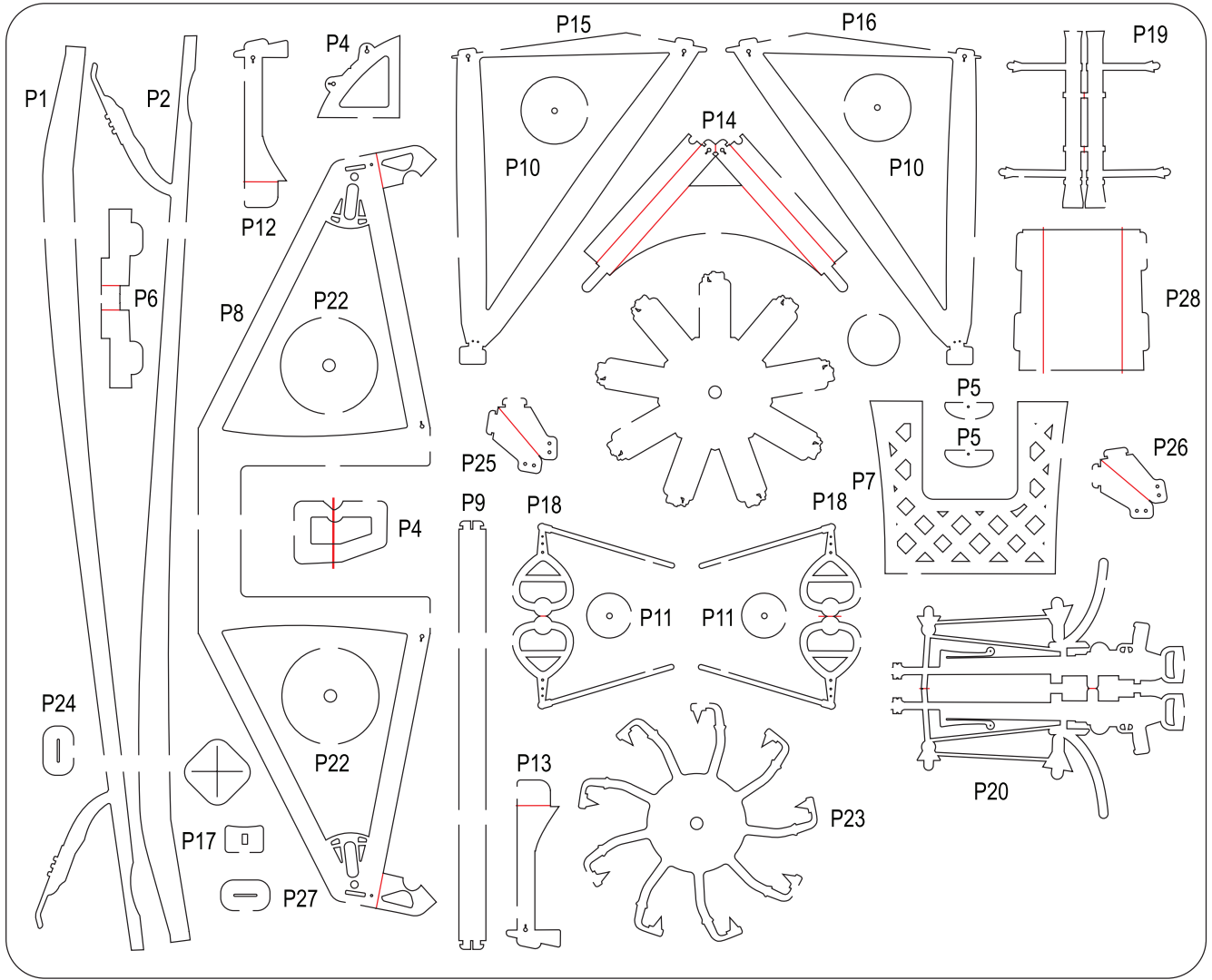

1mm FOAM

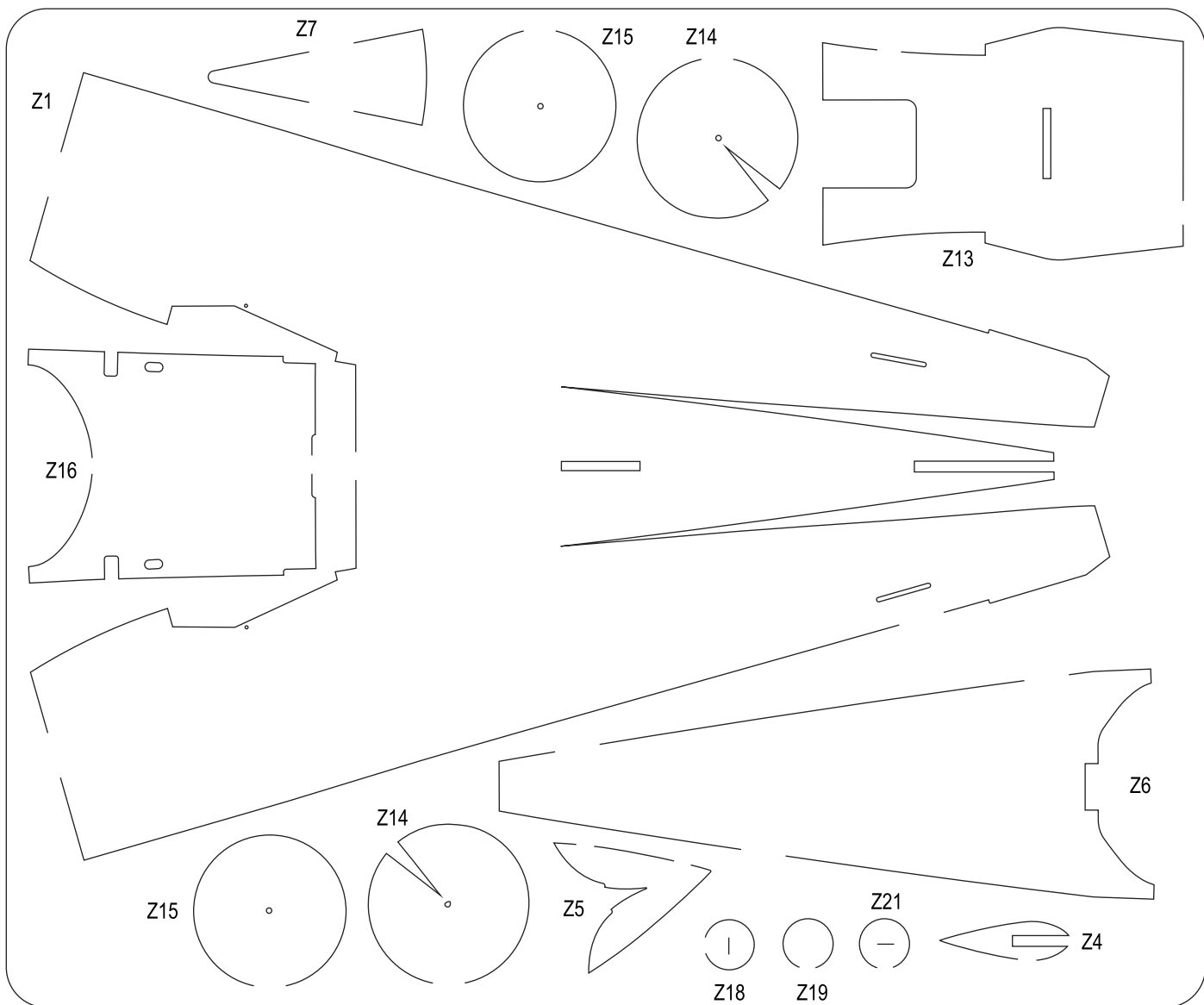

0.8mm PLYWOOD

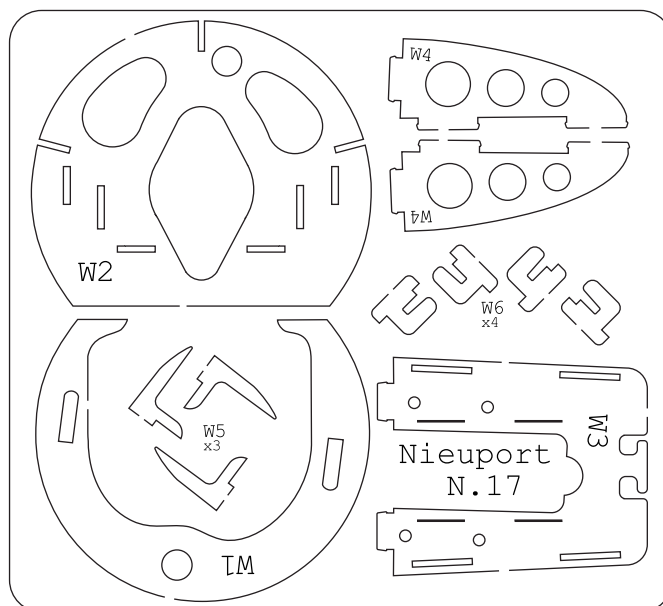

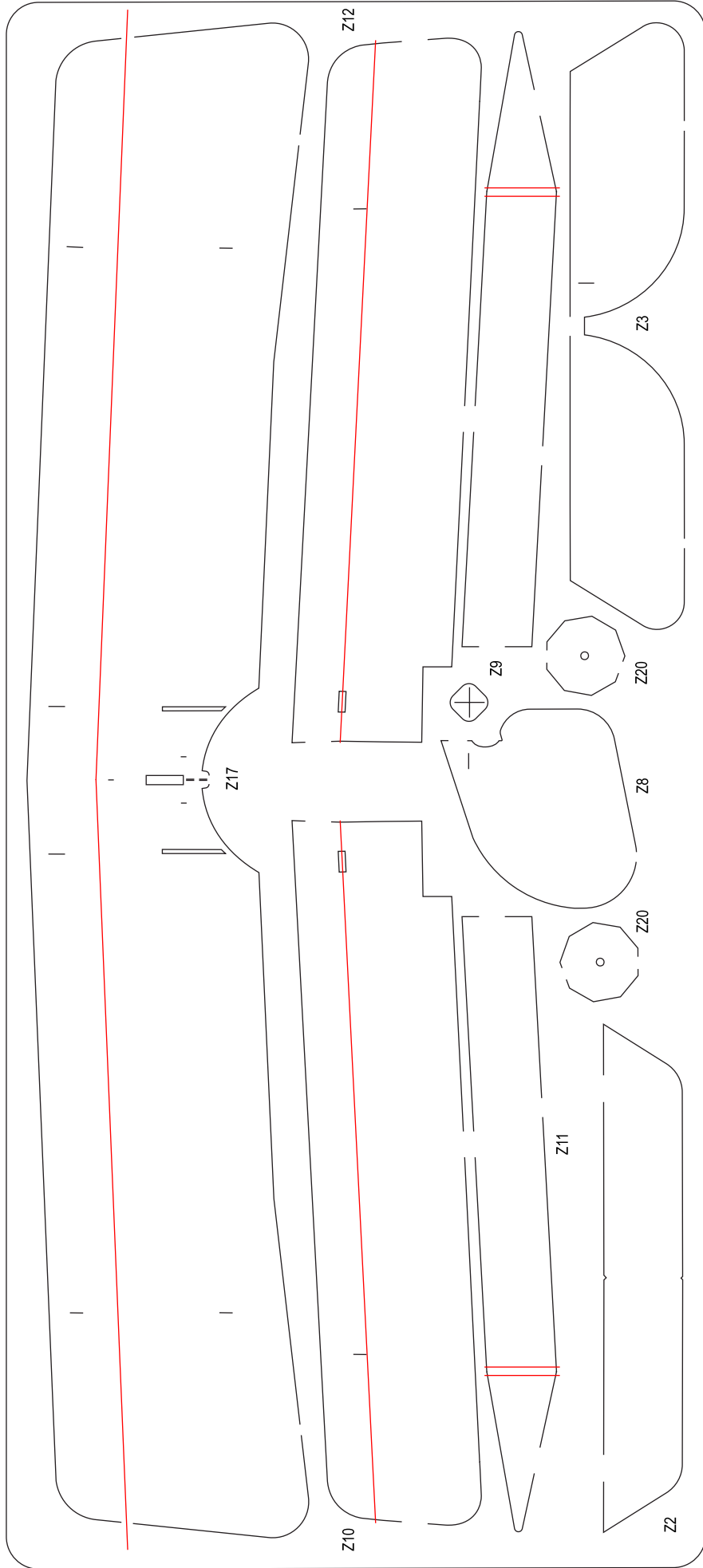

STICKERS

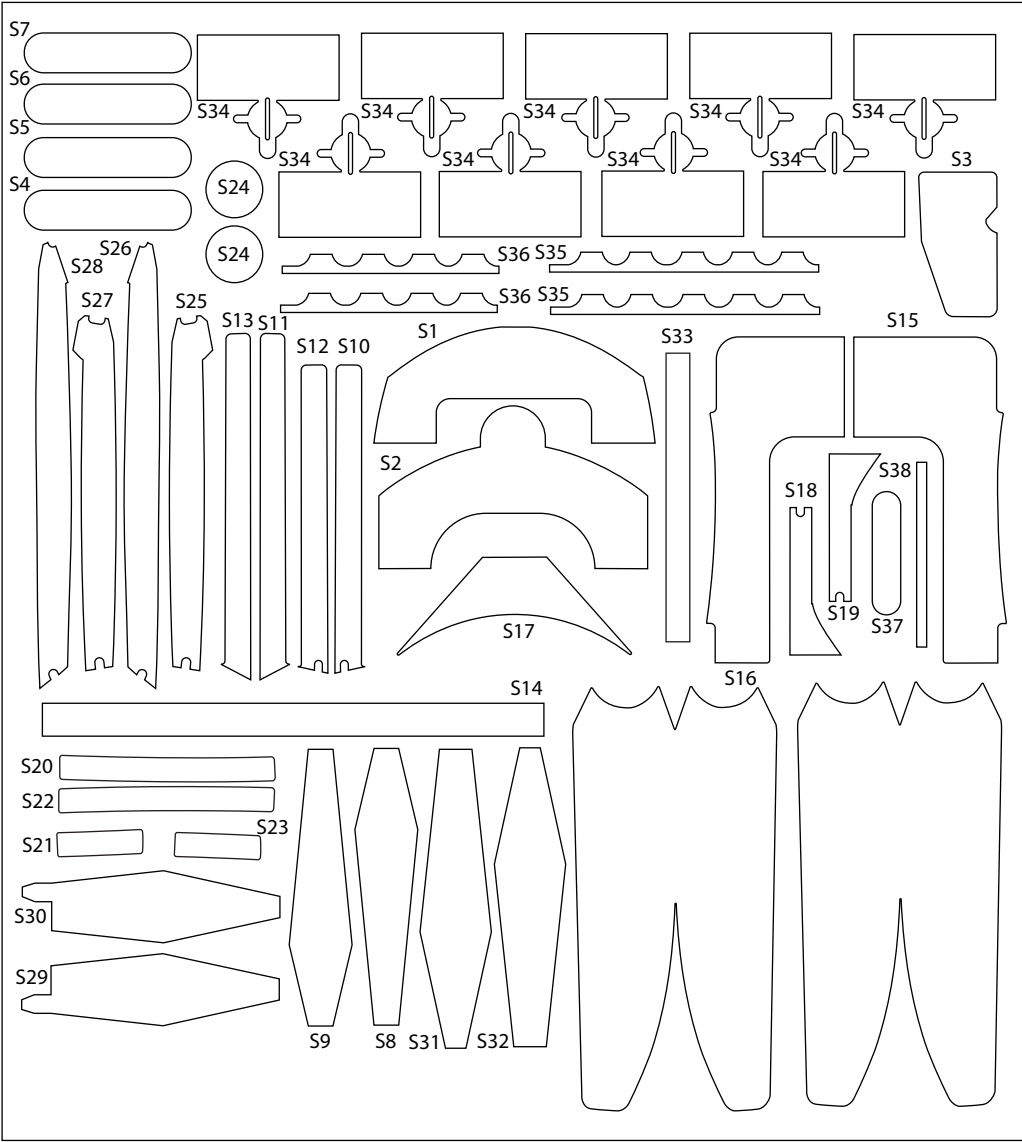

PILOT

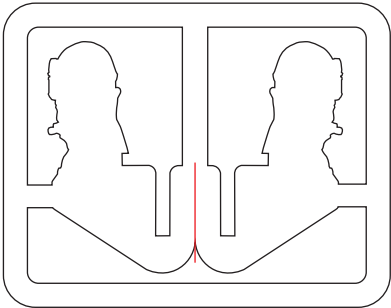

SCORING & BEVELING GUIDE #1

Method for scoring 1mm Foam

Using a straight edge as a guide, score the depron with the reverse side of a craft knife or a ball point pen.

If you haven't used this technique before it is essential that you practice using a scrap or spare piece of 1mm Depron prior to processing any kit components.

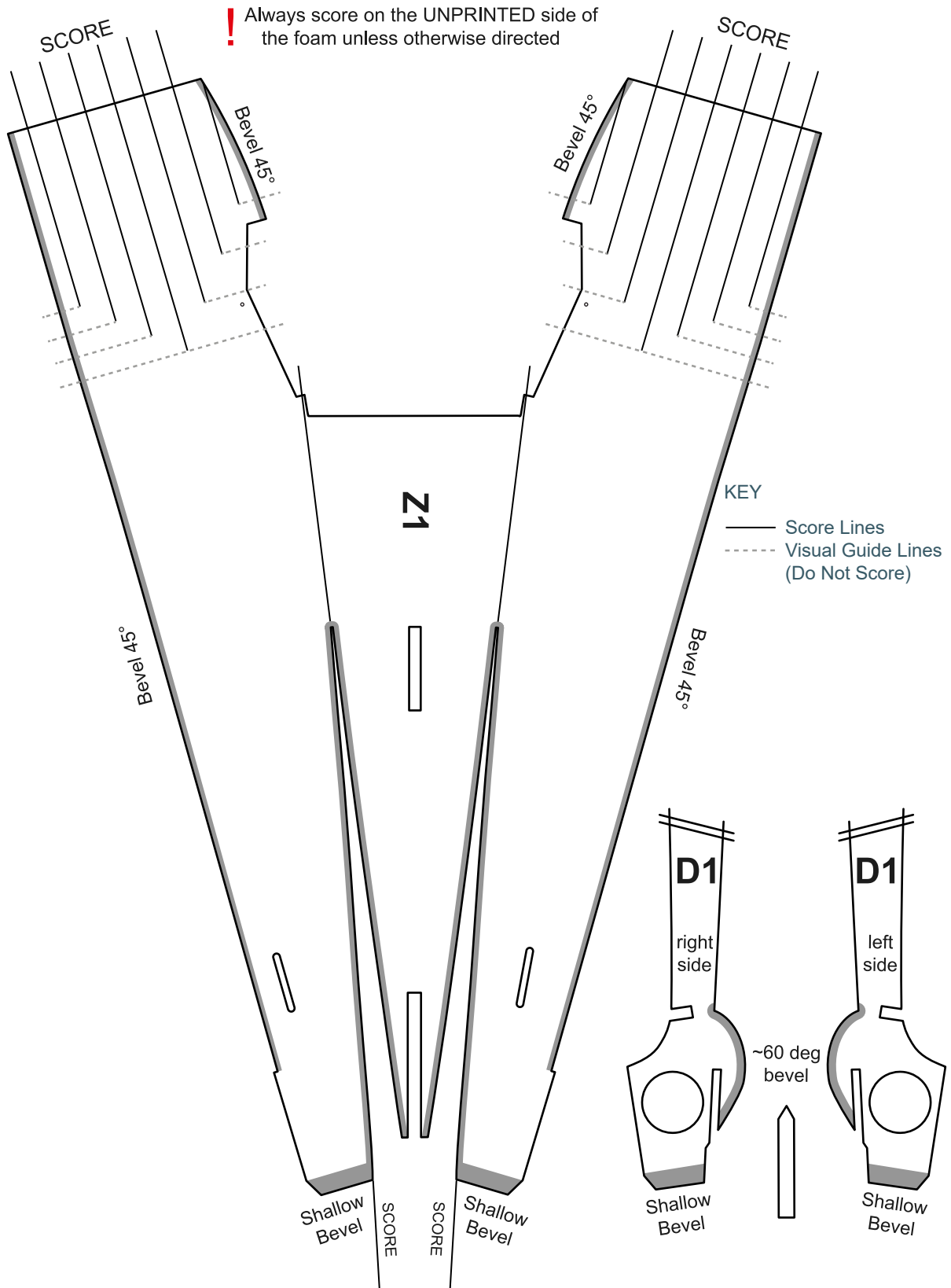

Drawn to scale: Print without scaling and use for scoring parts indicated

SCORING & BEVELING GUIDE #2

Method for scoring 1mm Foam

Using a straight edge as a guide, score the depron with the reverse side of a craft knife or a ball point pen.

If you haven't used this technique before it is essential that you practice using a scrap or spare piece of 1mm Depron prior to processing any kit components.

! Always score on the UNPRINTED side of the foam unless otherwise directed

KEY

— Score Lines

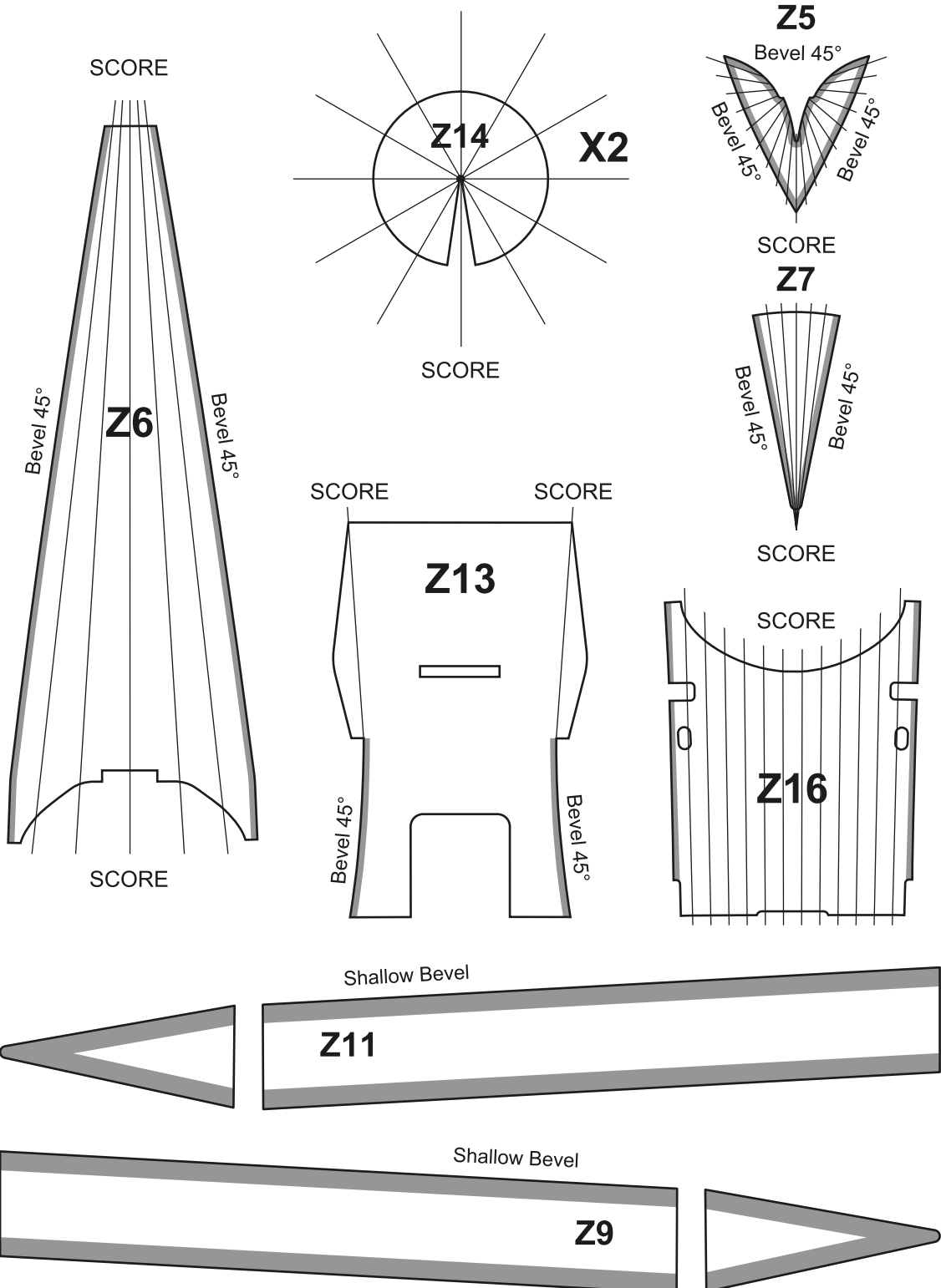

STAGE 1 AIRFRAME



The plastic parts used in the airframe are there to increase the strength of the structure in vital areas whilst still providing some flexibility.



Apply a thin layer of adhesive to the plastic part and attach immediately to allow some wiggle time to get the parts lined up. Set aside to cure.



Scan for Video Guide

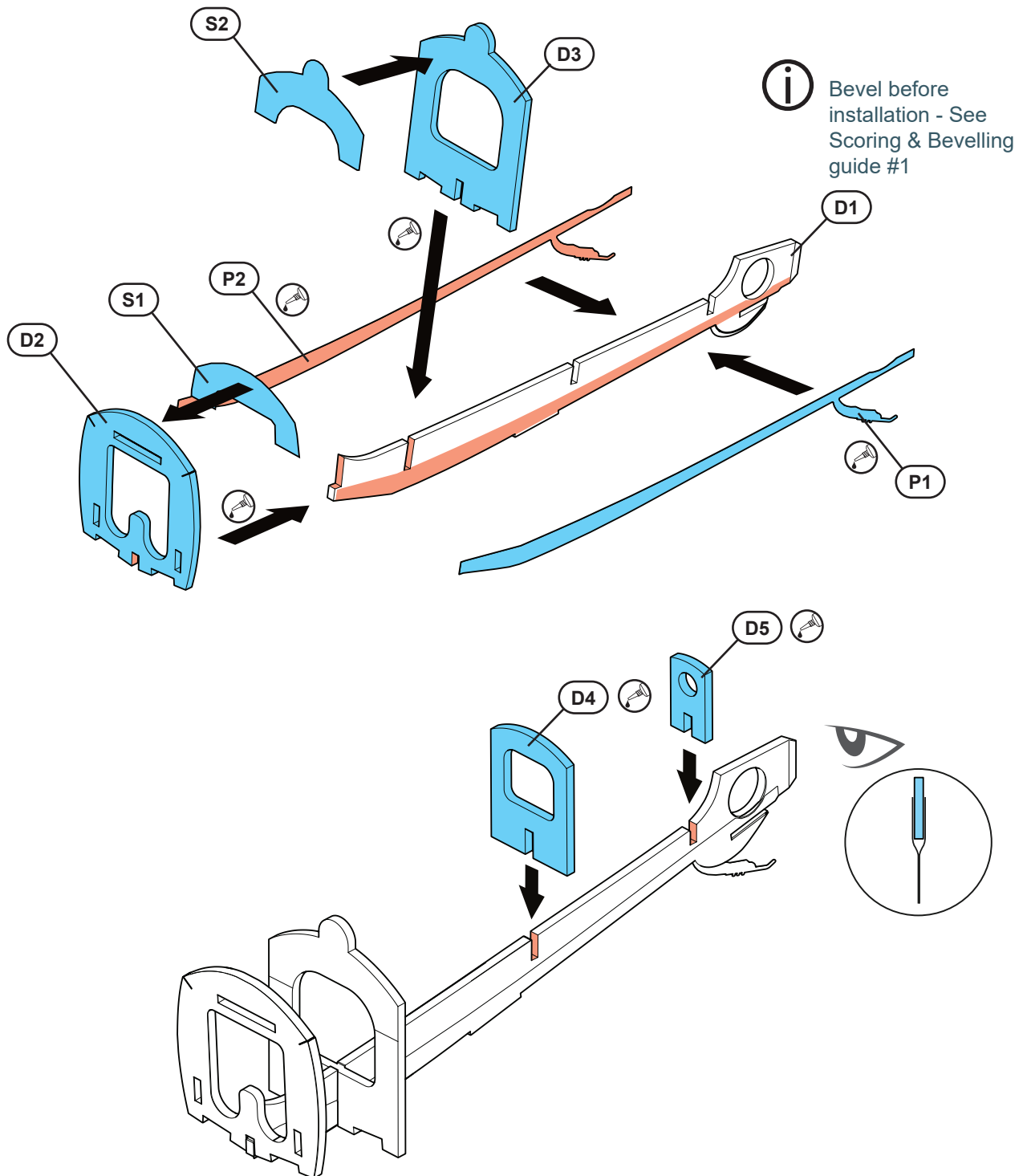

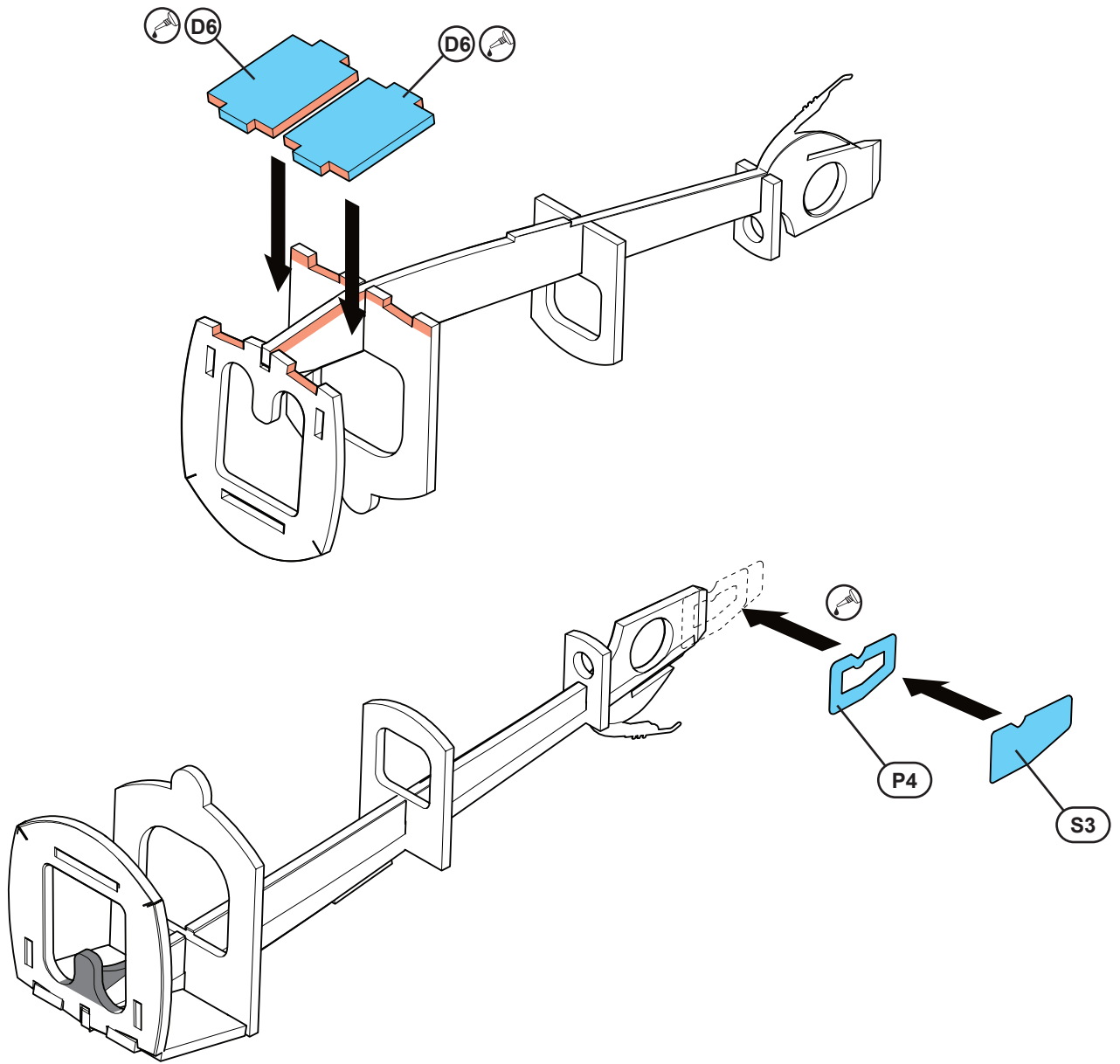

i Remove shaded area for better battery positioning

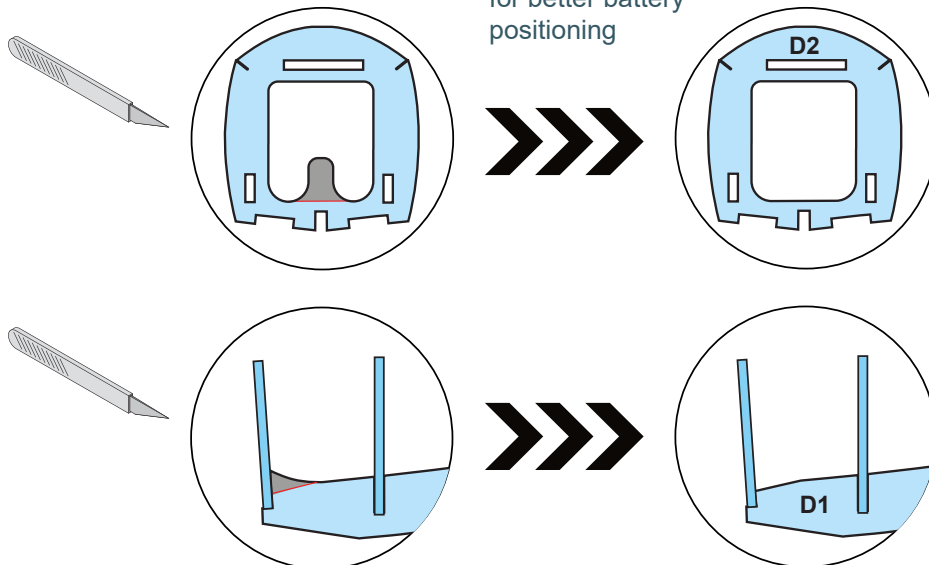

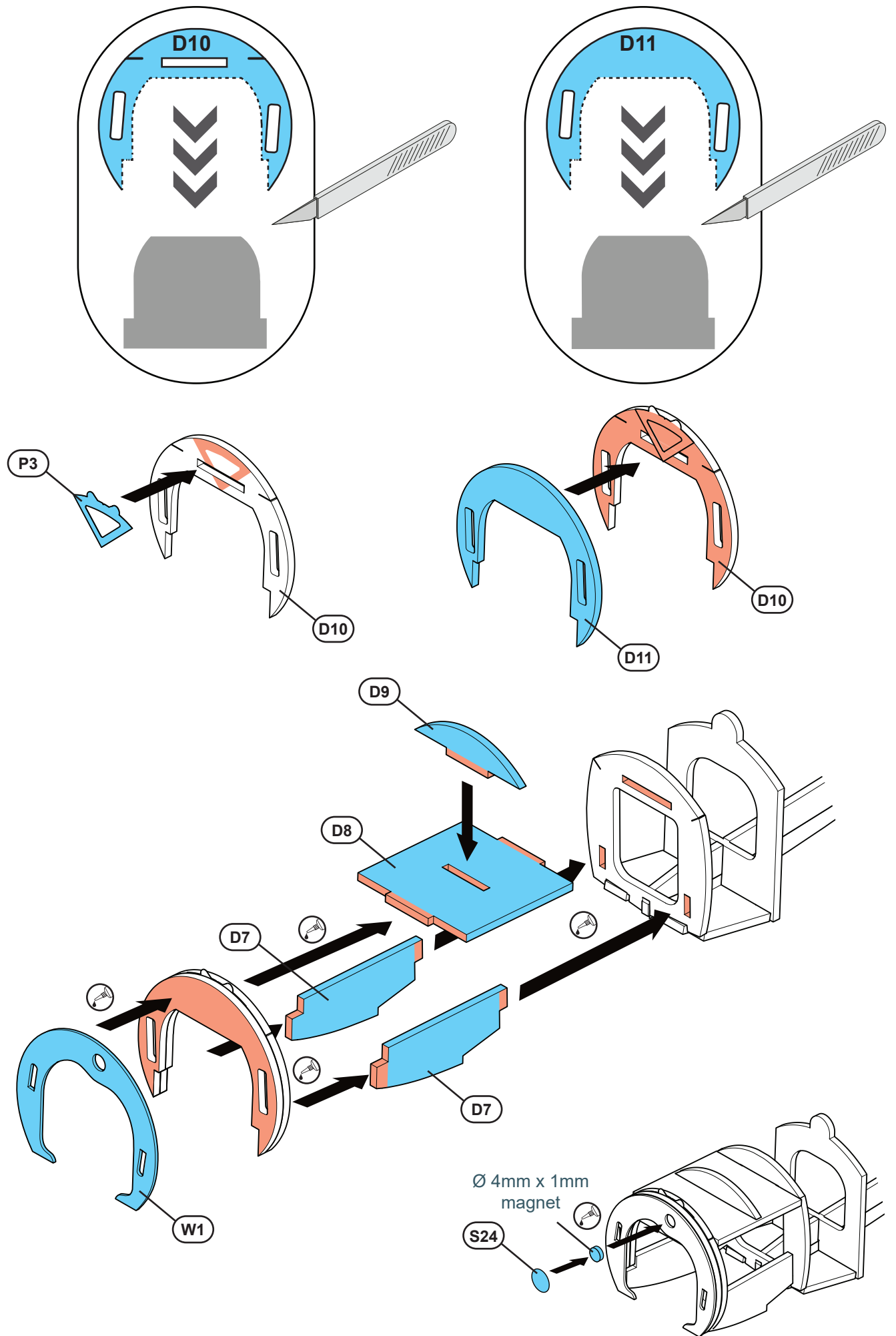

STAGE 2 FUSELAGE

⚠ Dry fit before gluing



Scan for Video Guide

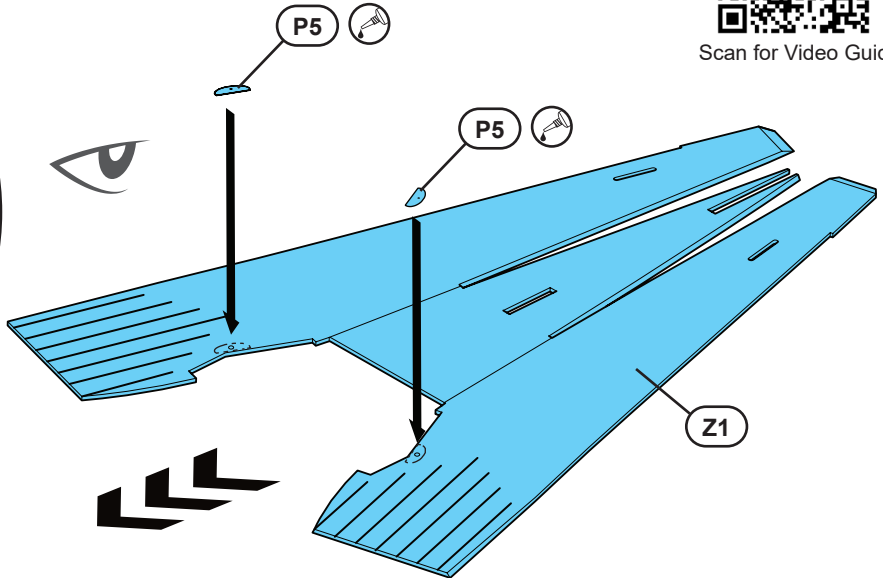
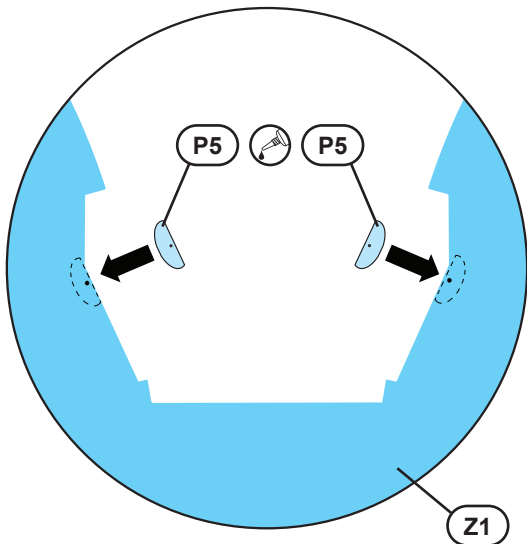

500mm length of rigging wire

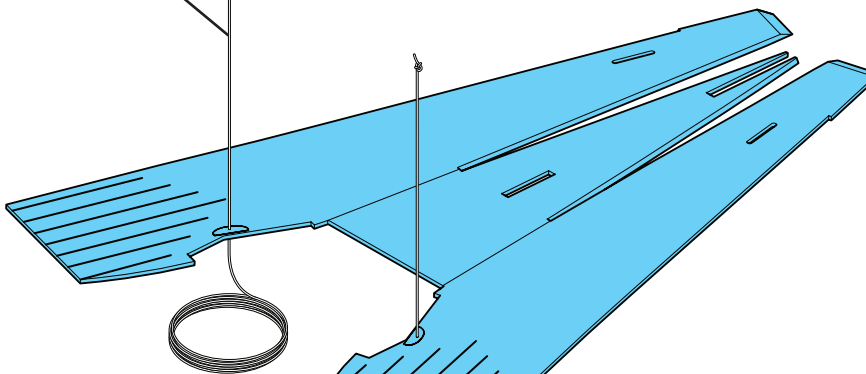

i Bevel & Score before installation - See Scoring & Bevelling guide #1



i Pre-bend scored areas on part prior to installation to make fitting easier.

i Attach 500mm of Rigging wire to each side of the fuselage skin as illustrated. Ensure the rigging is installed BEFORE Z1 is attached to the airframe.

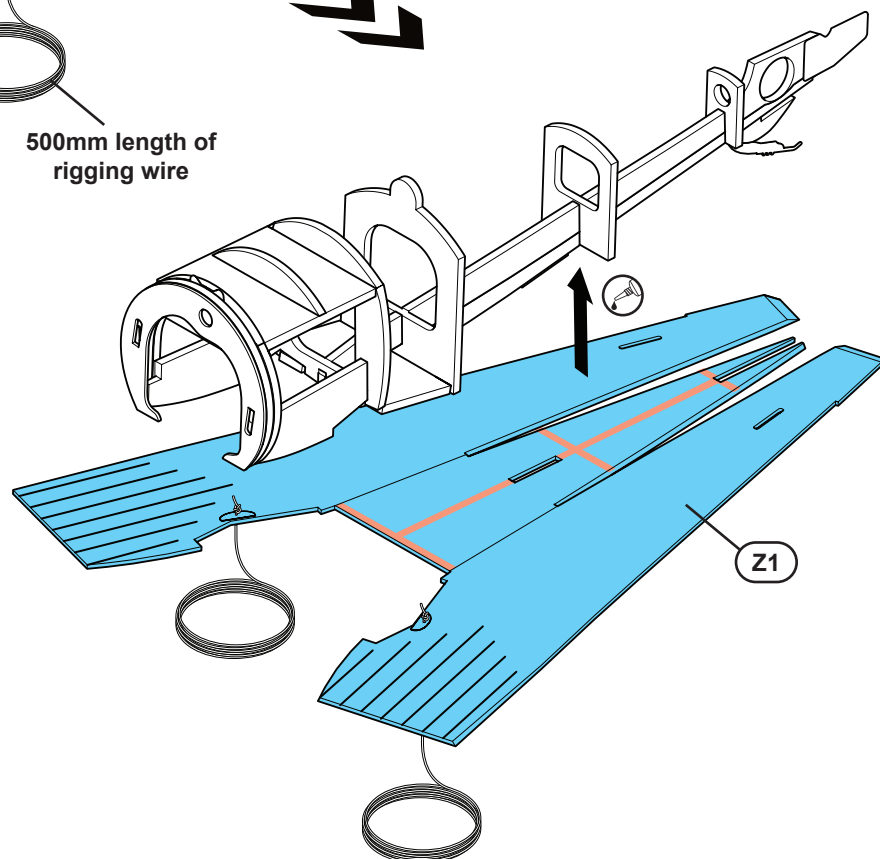
500mm length of rigging wire



STAGE 2 FUSELAGE

-  Bevel & Score before installation - See Scoring & Beveling guide #2
-  Pre-bend scored areas on part prior to installation to make fitting easier.

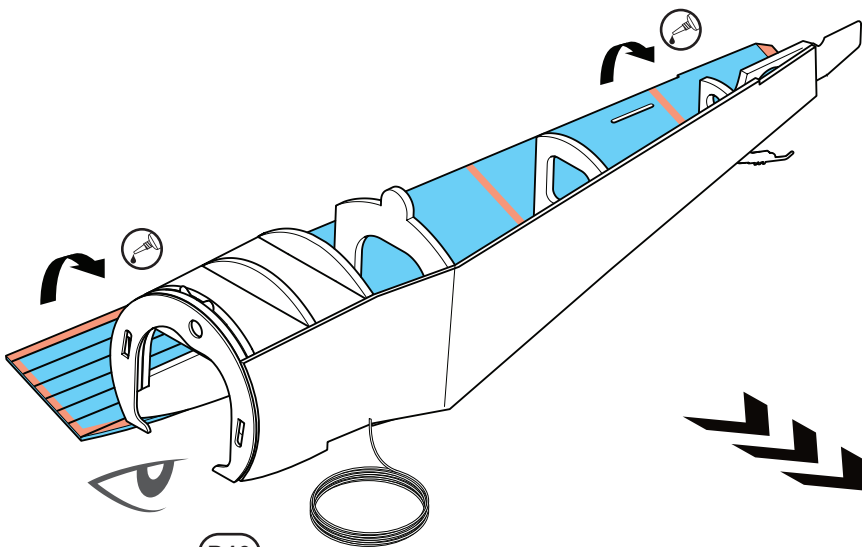
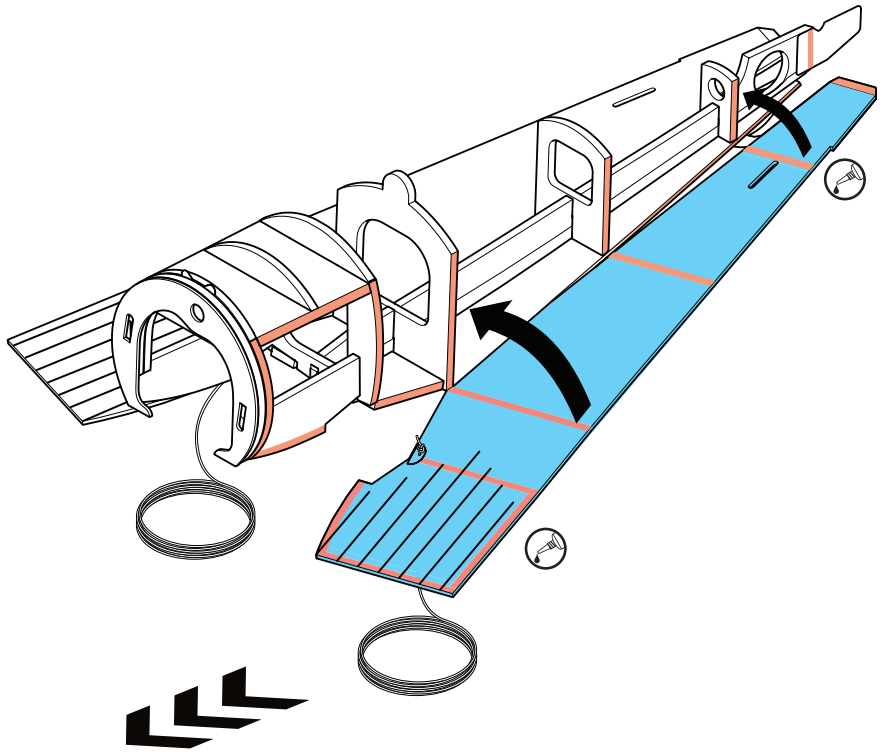

 Dry fit before gluing

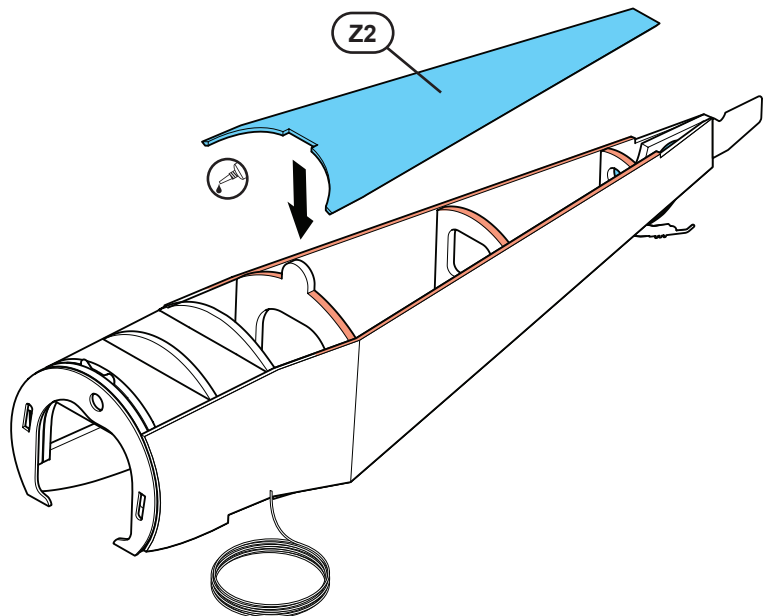
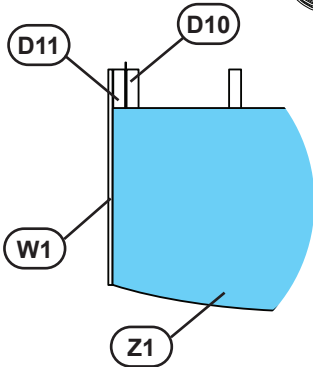

STAGE 3 TAIL



Scan for Video Guide

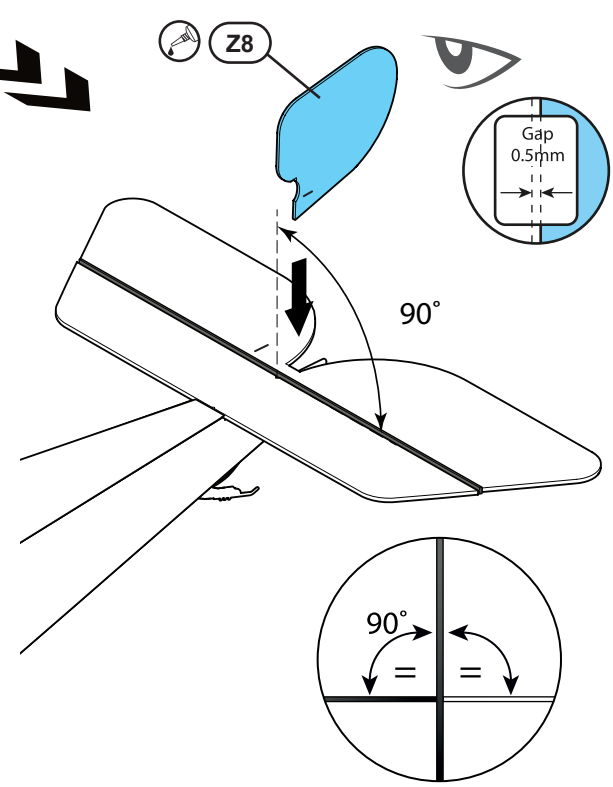
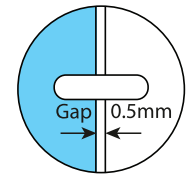
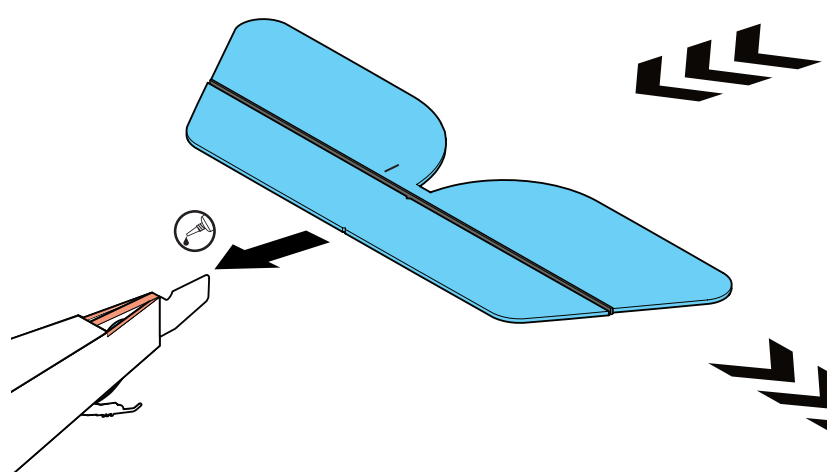
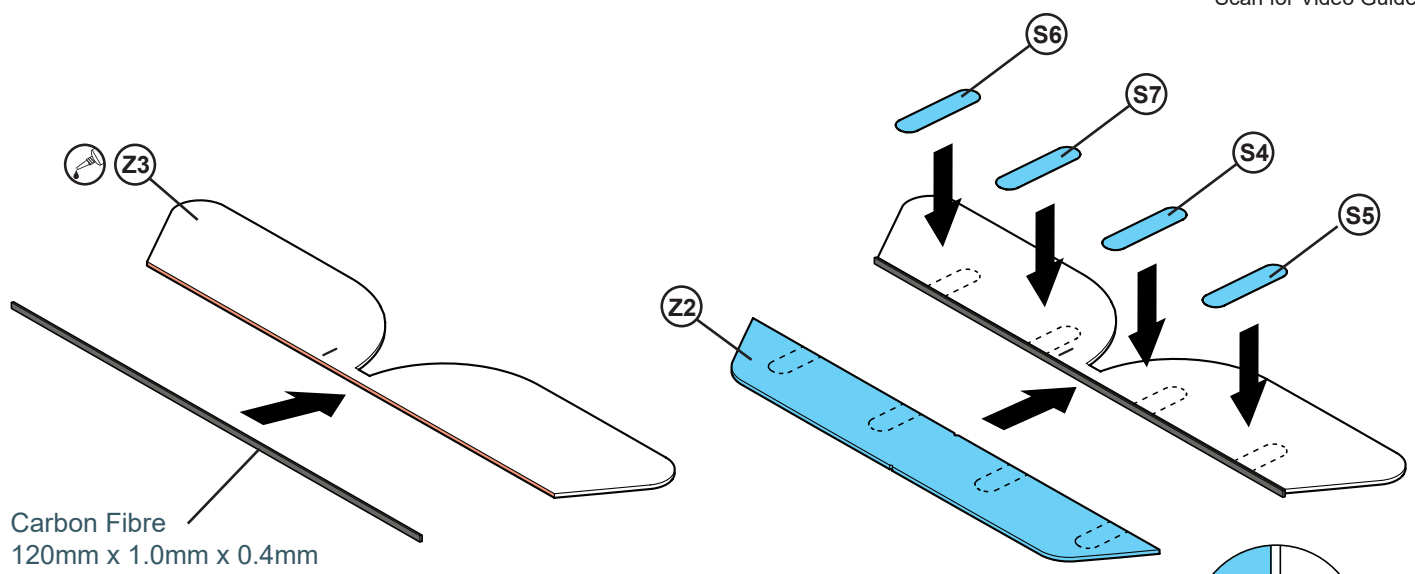

i To attach rudder, glue to plastic hinge P4 and sticker S3

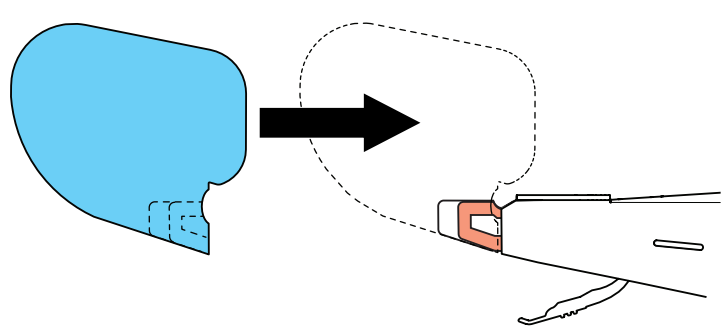

STAGE 3 TAIL

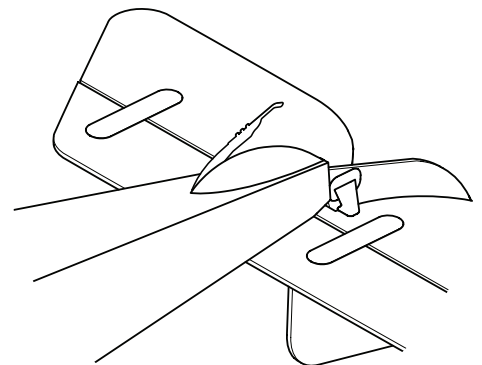
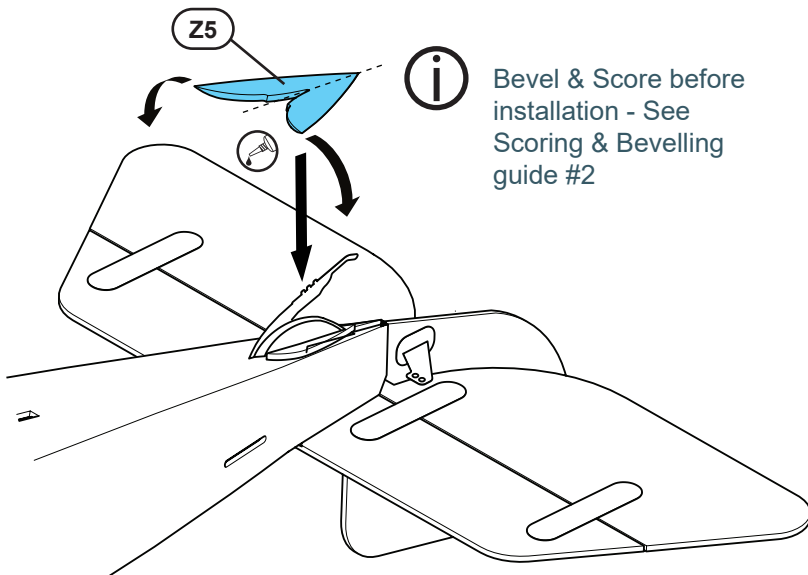
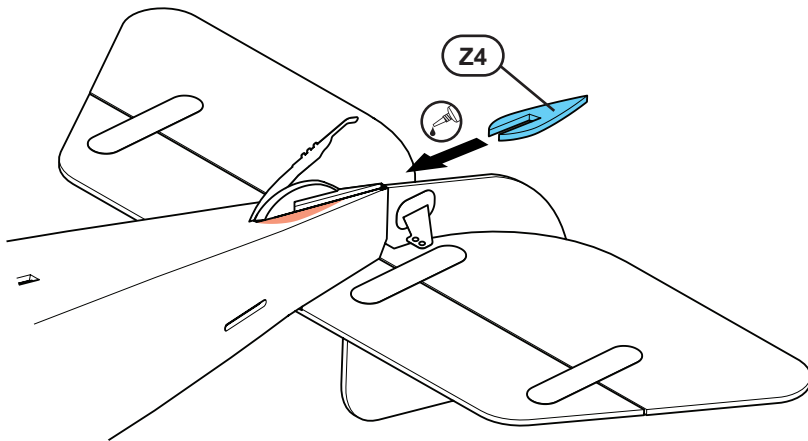
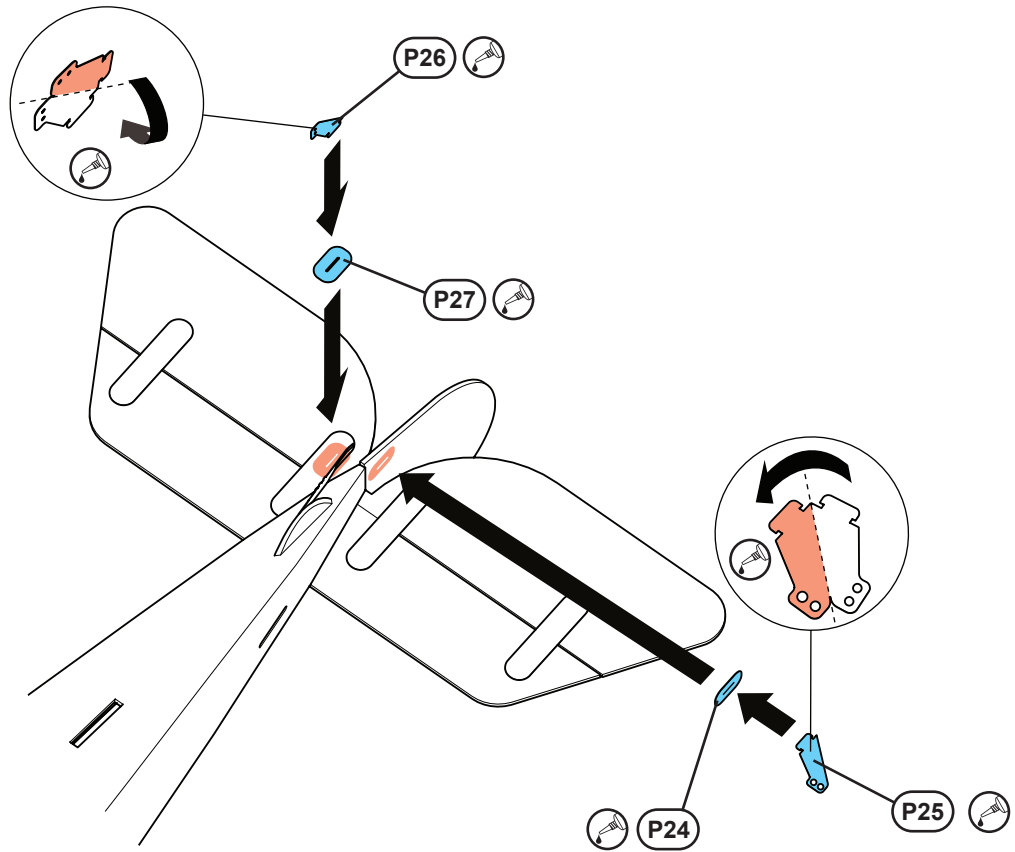

STAGE 4 LOWER WING



Scan for Video Guide

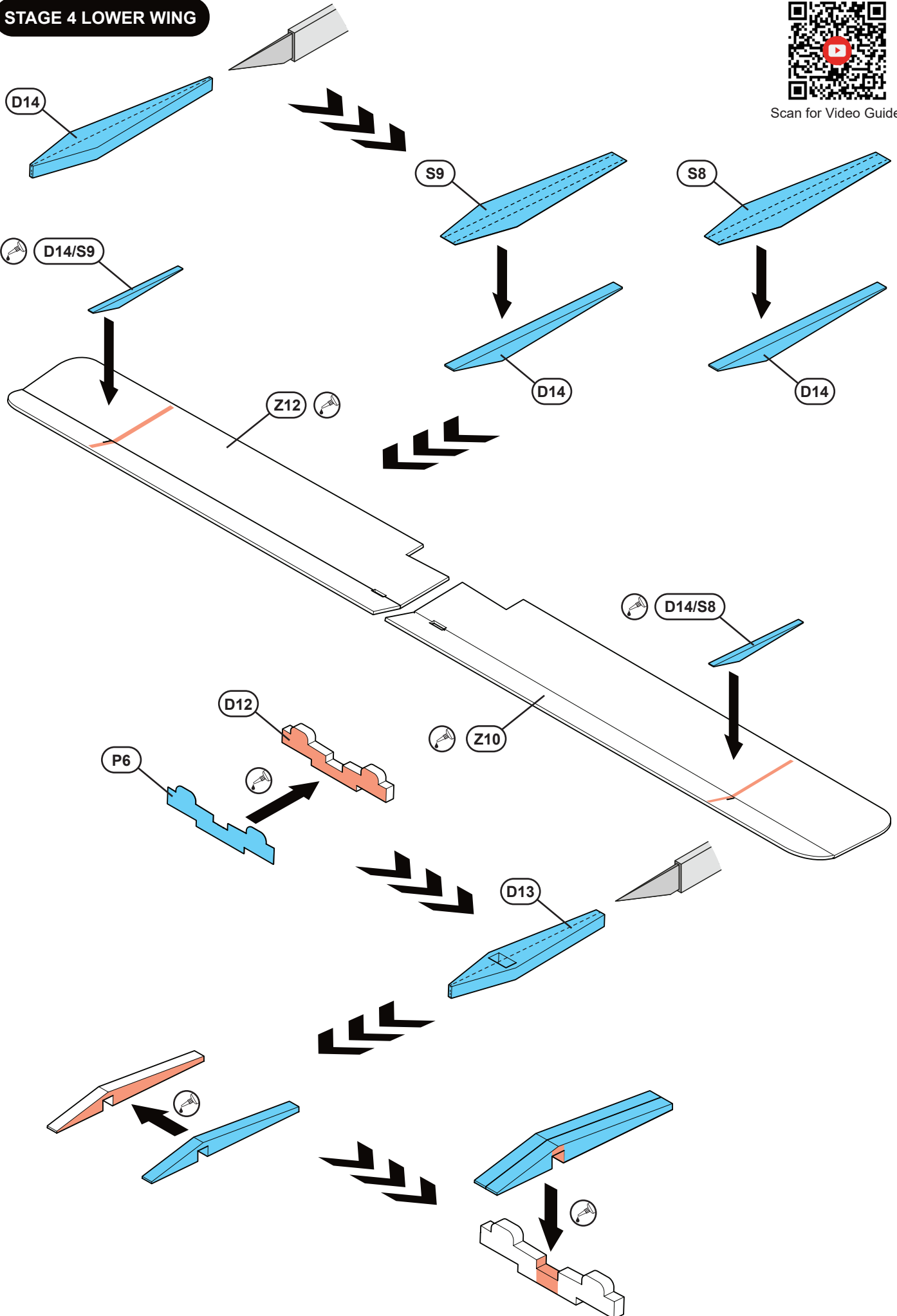

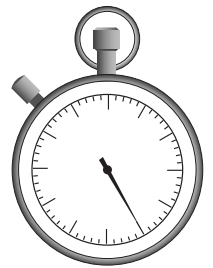
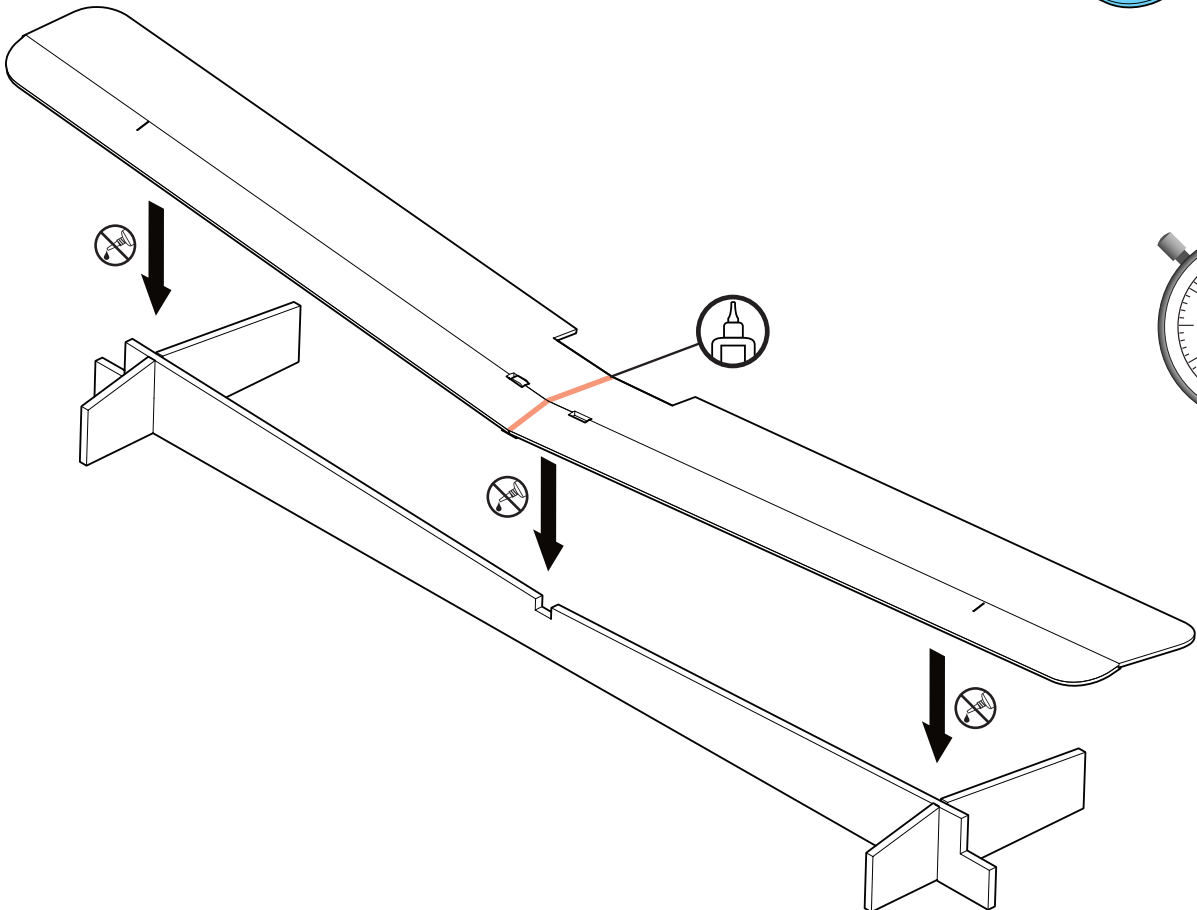
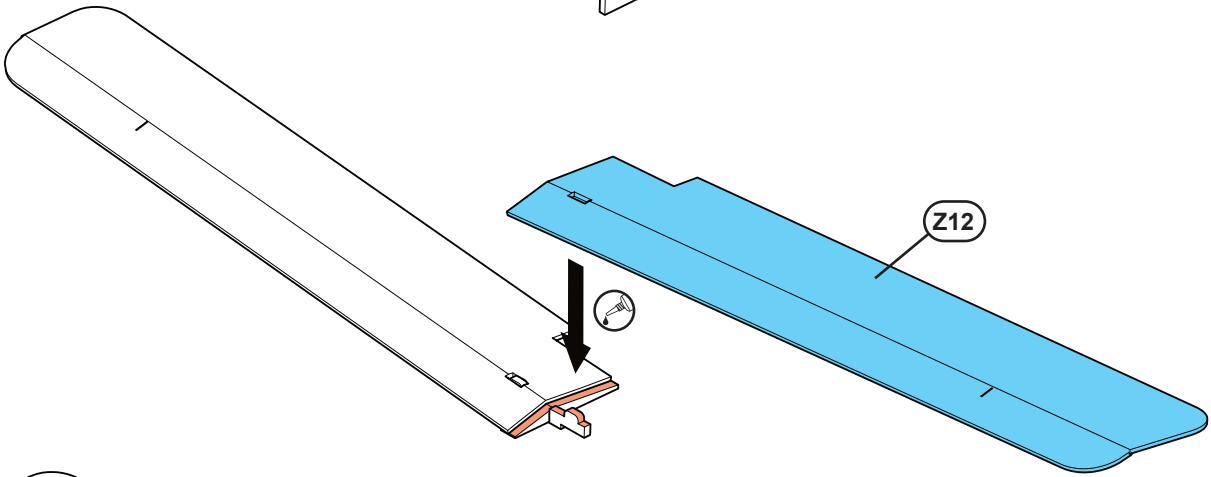
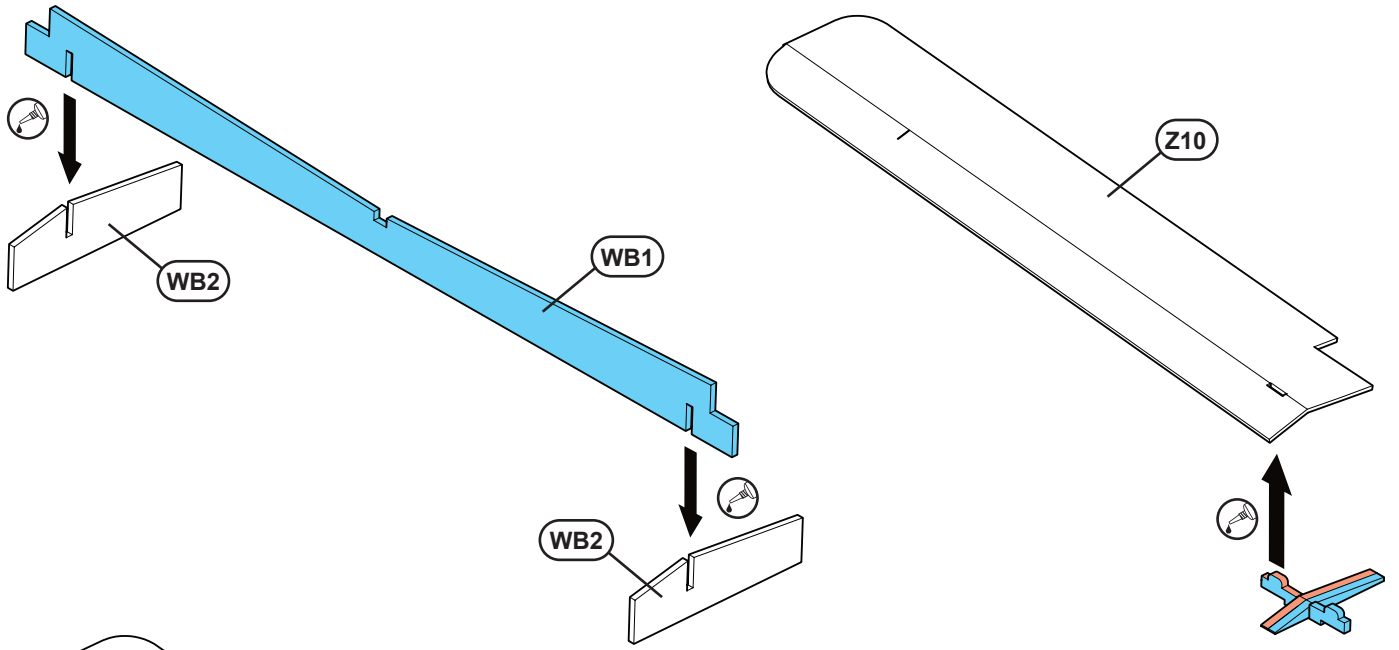

Time
1 Hour

STAGE 4 LOWER WING

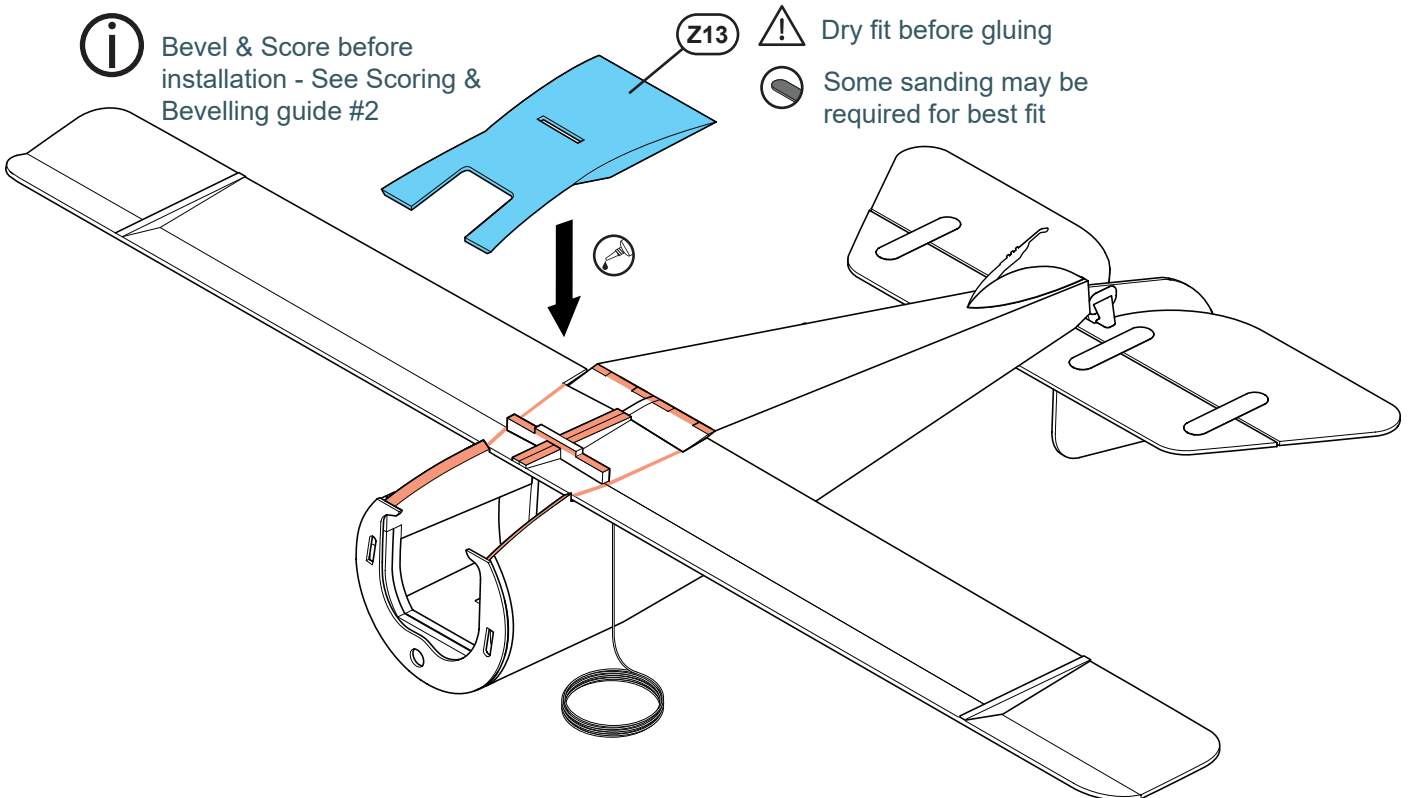
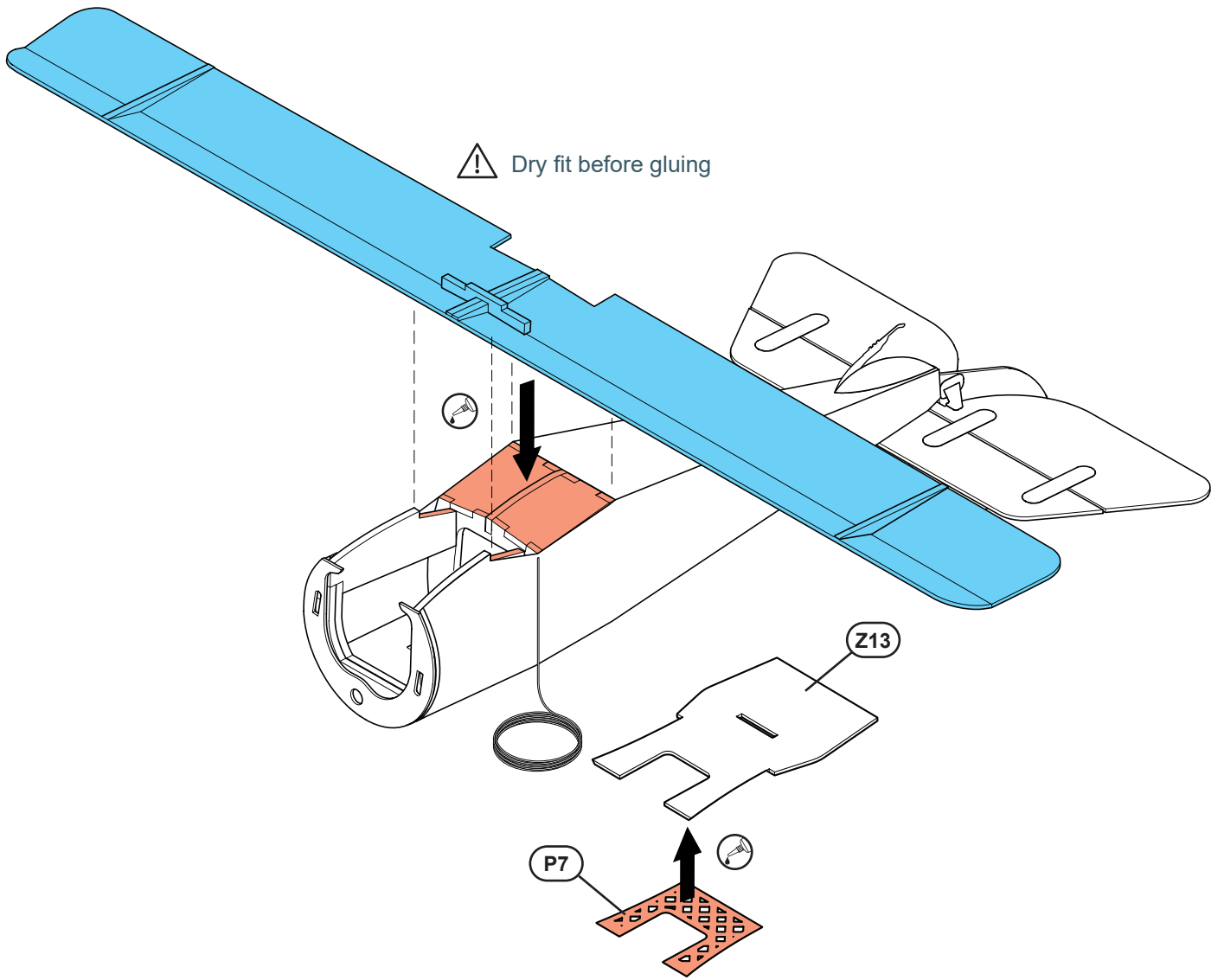

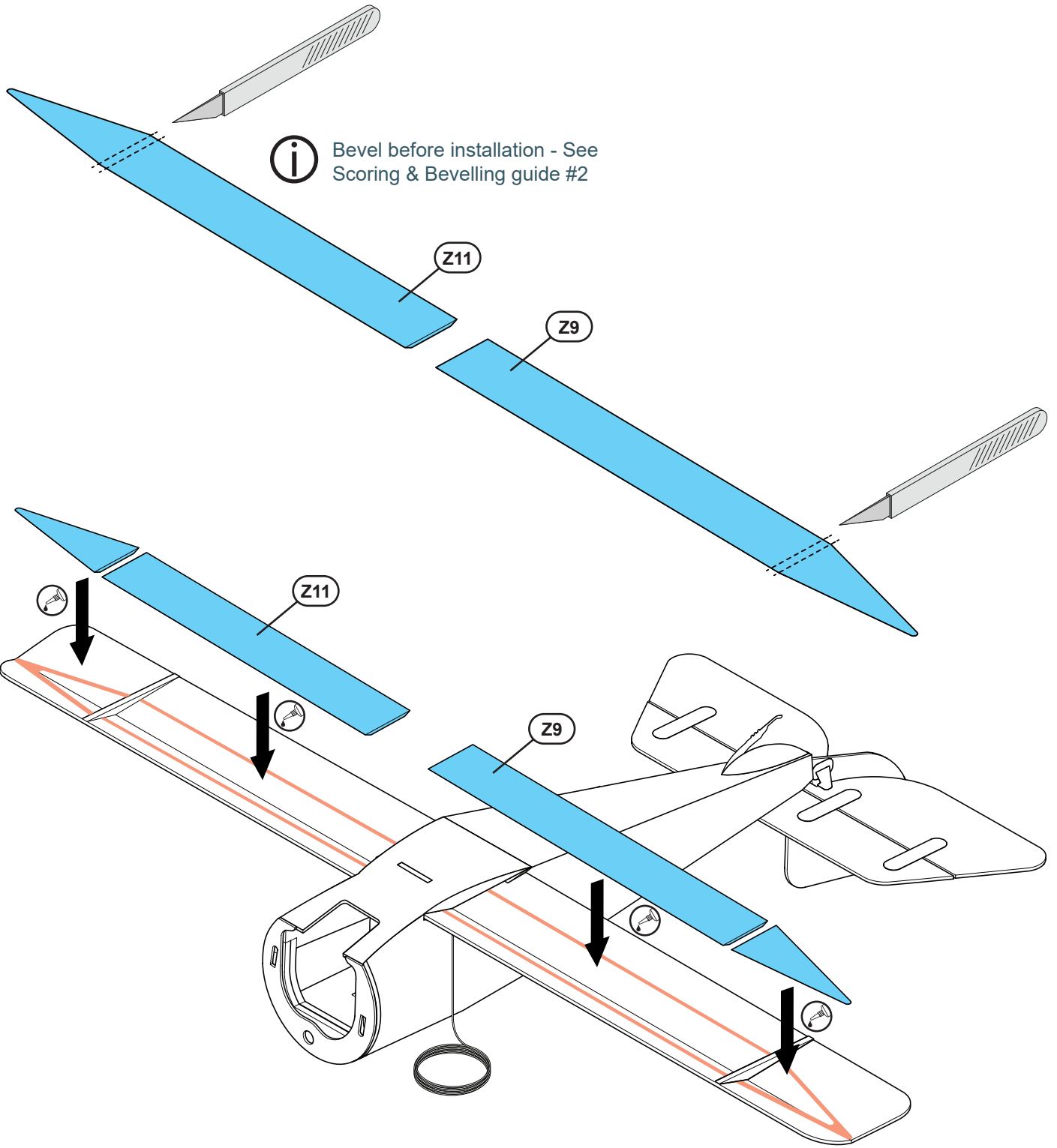

STAGE 5 UNDERCARRIAGE



Scan for Video Guide

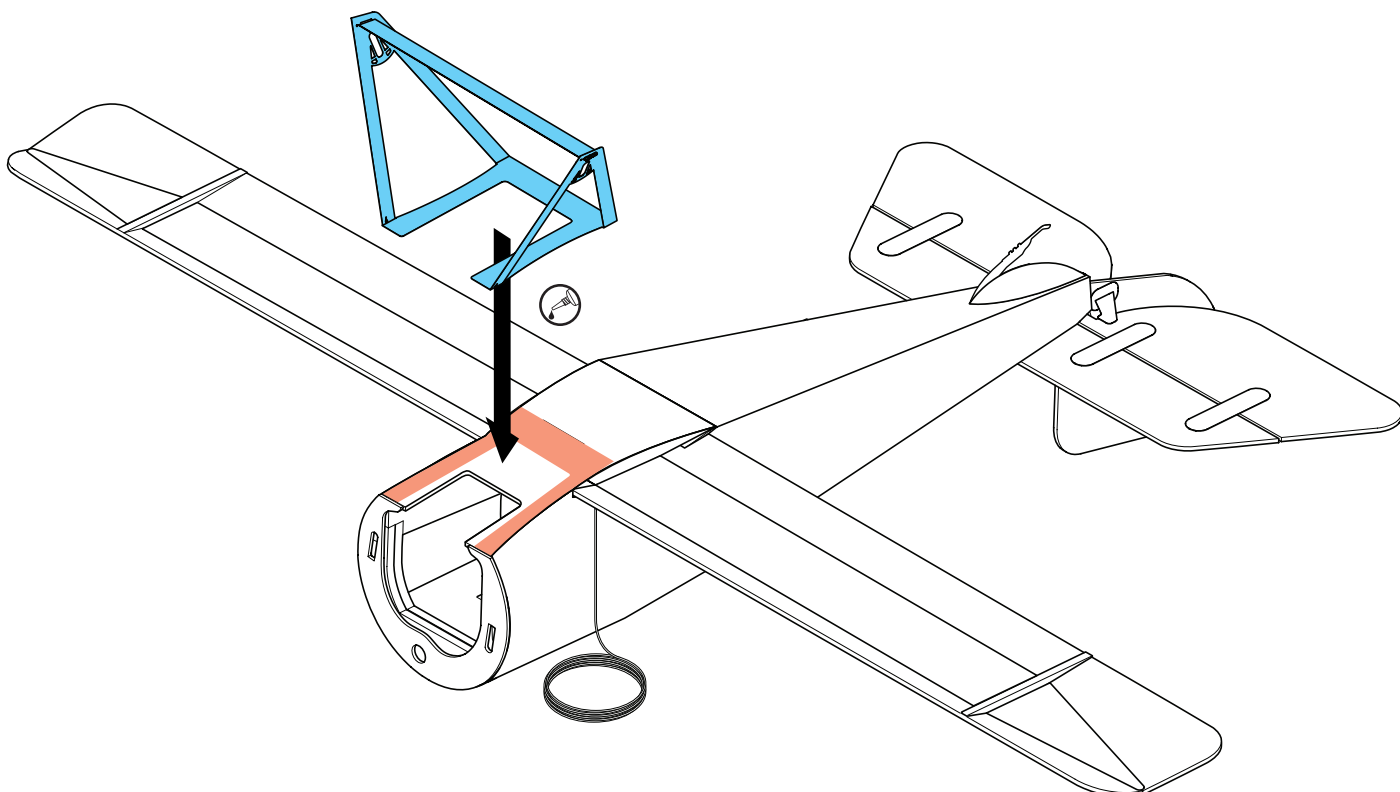
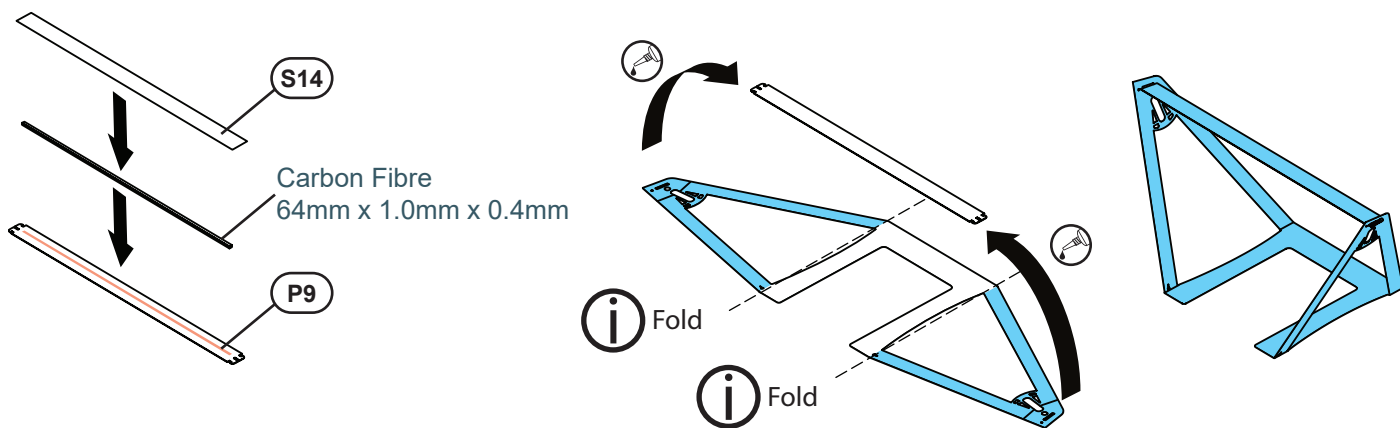
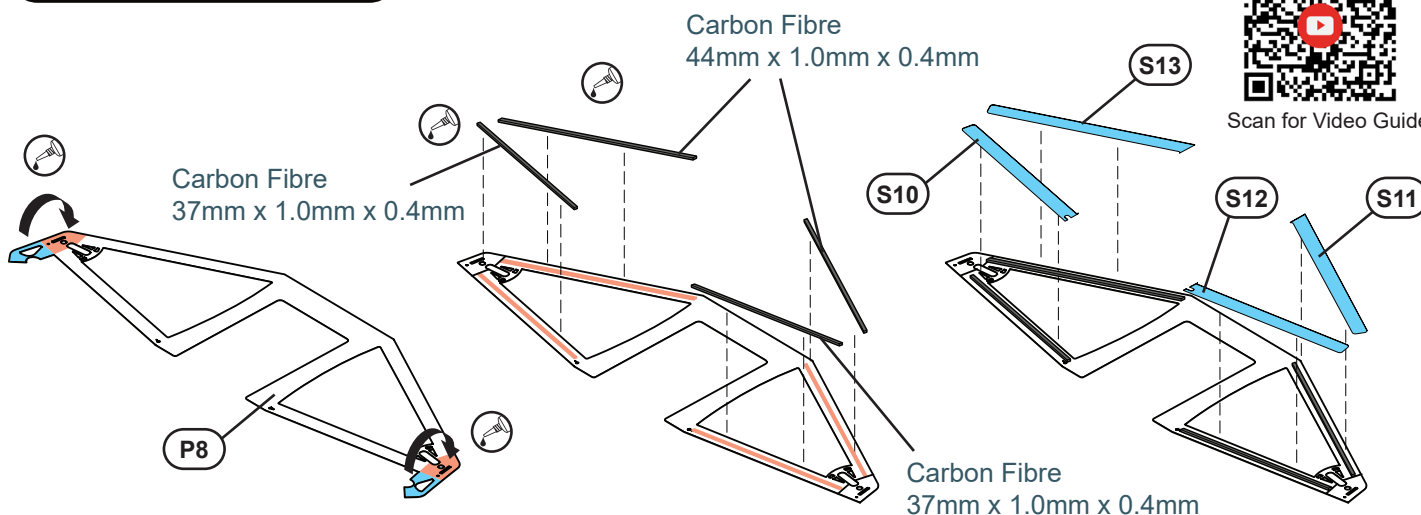

STAGE 5 UNDERCARRIAGE

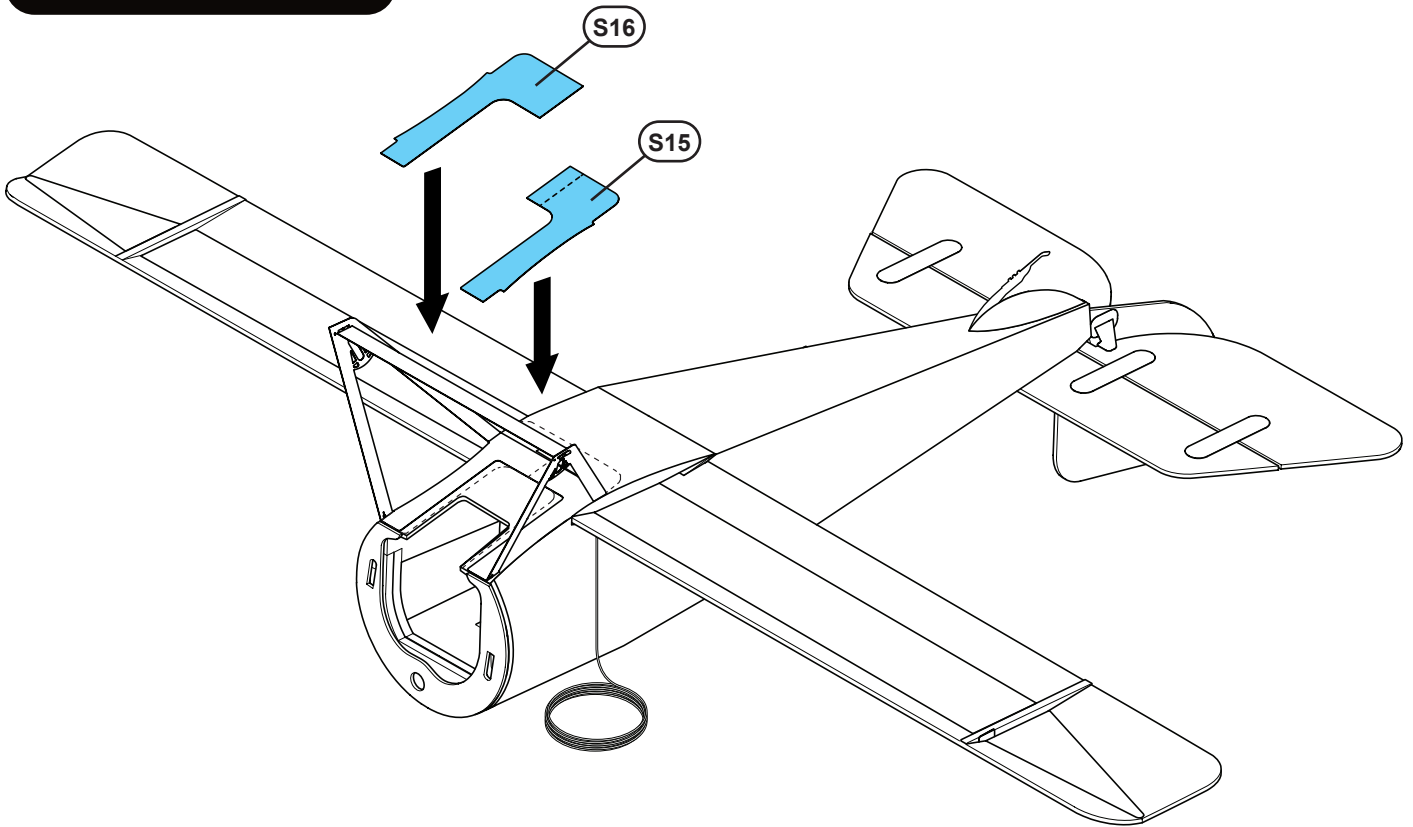

STAGE 6 STRUTS



Scan for Video Guide

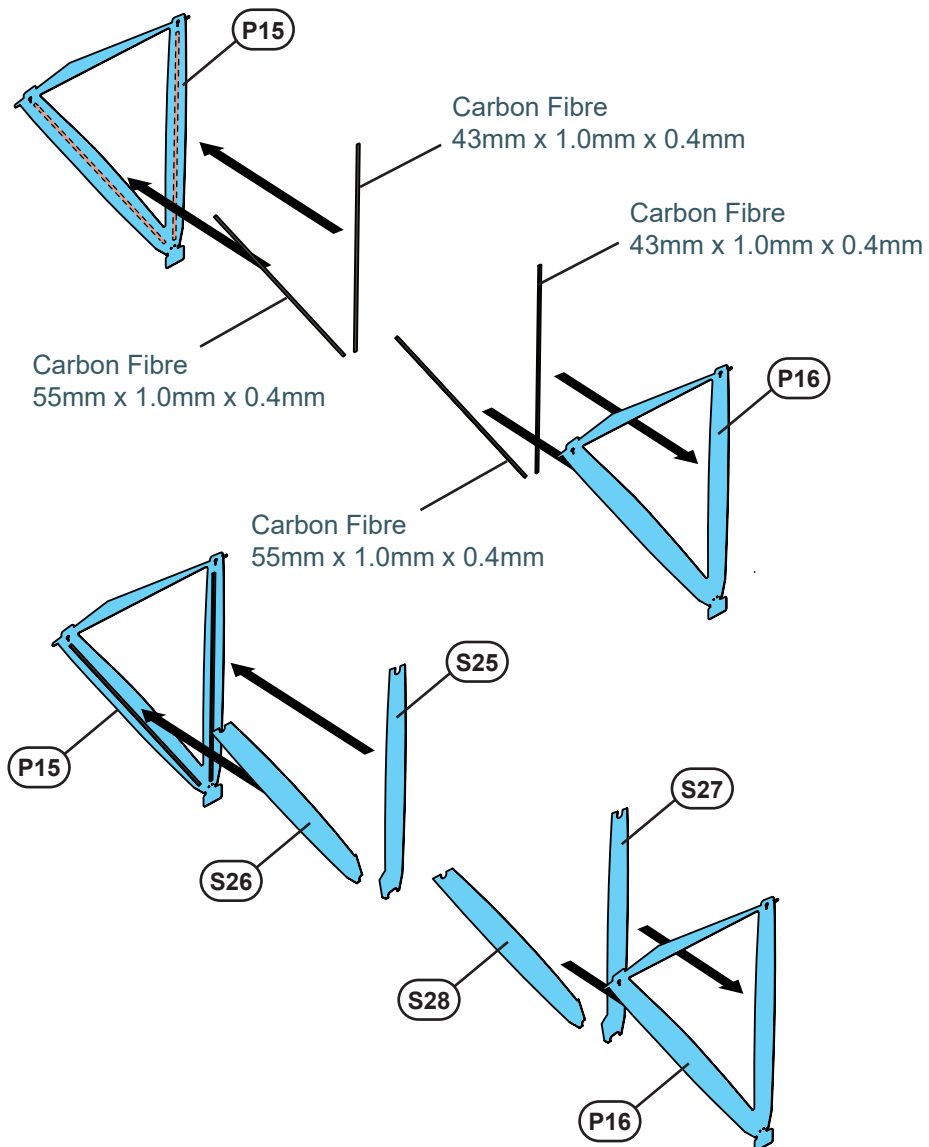

STAGE 6 STRUTS

Carbon Fibre
17mm x 1.0mm x 0.4mm

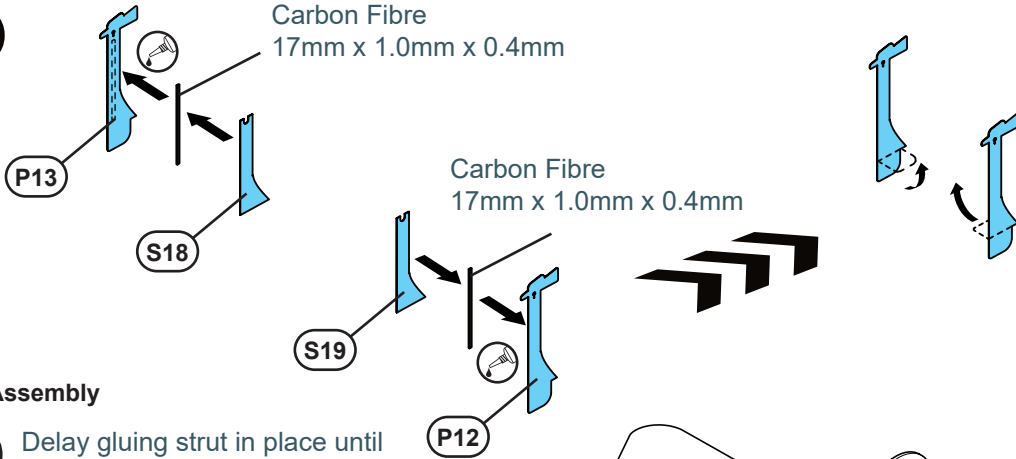

P15 Assembly



Delay gluing strut in place until rigging has been installed. See stage 11.

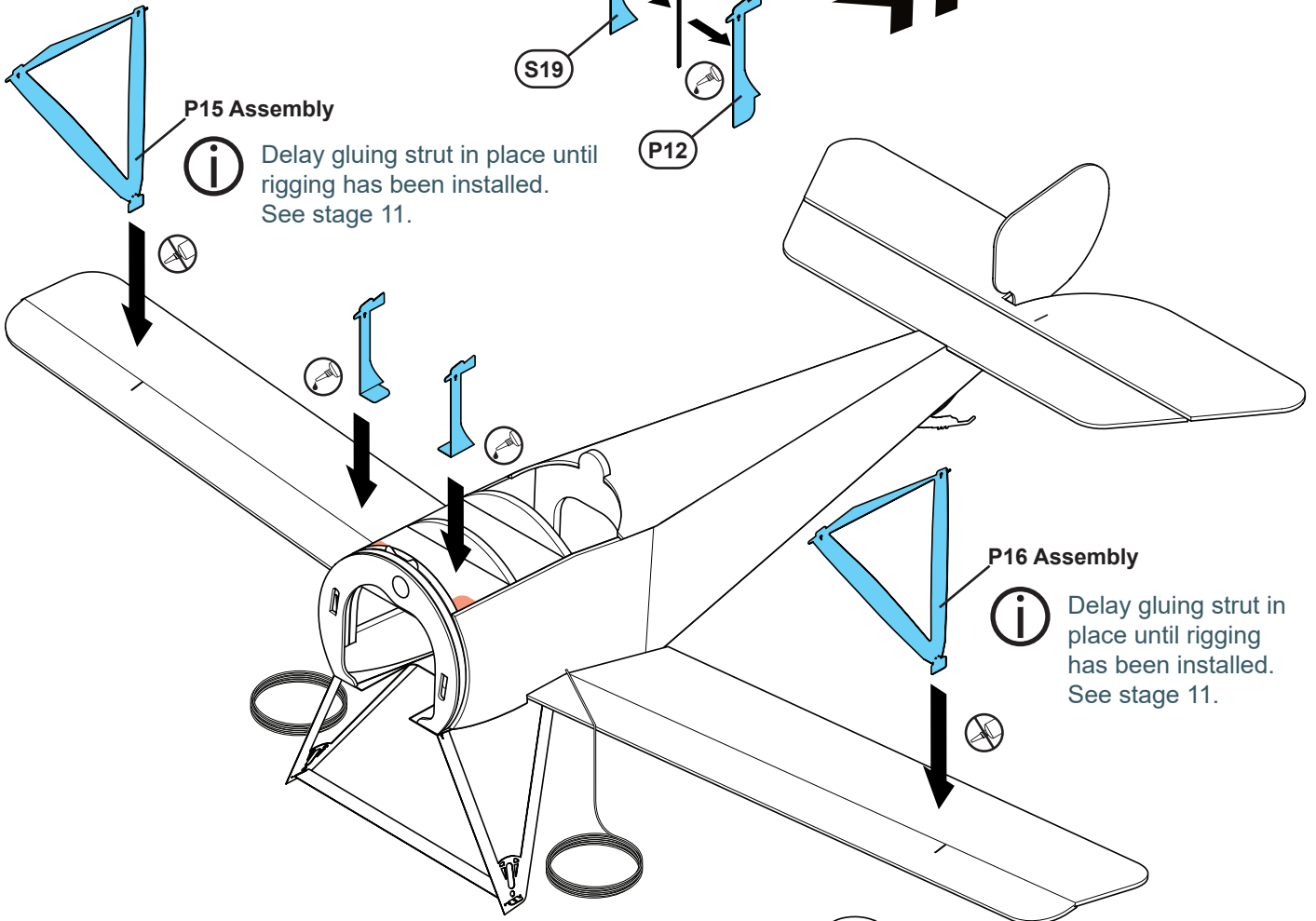

P16 Assembly



Delay gluing strut in place until rigging has been installed. See stage 11.



Score & Bevel before installation - See Scoring & Bevelling guide #2

Z16



Dry fit before gluing

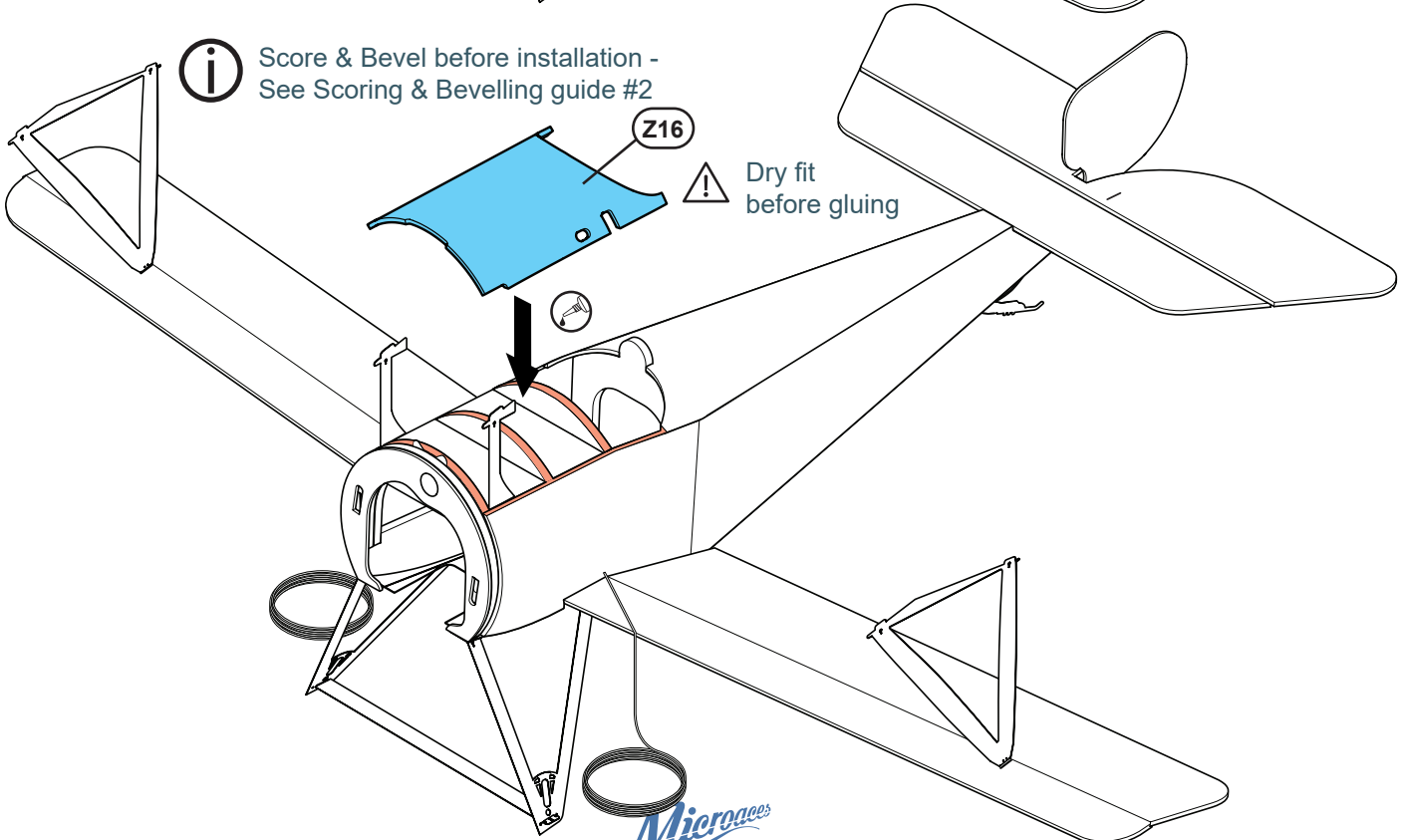

STAGE 7 DETAIL

i Score & Bevel before installation -
See Scoring & Beveling guide #2



Scan for Video Guide

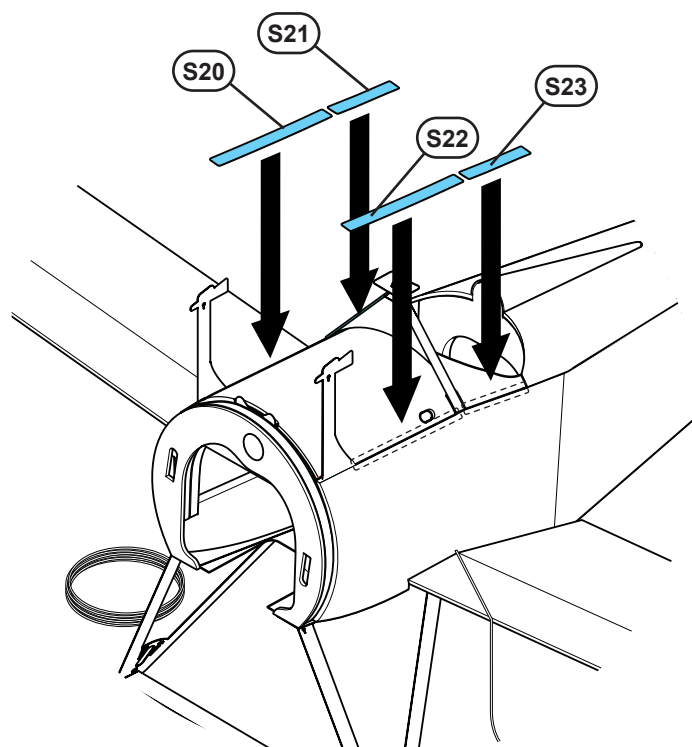
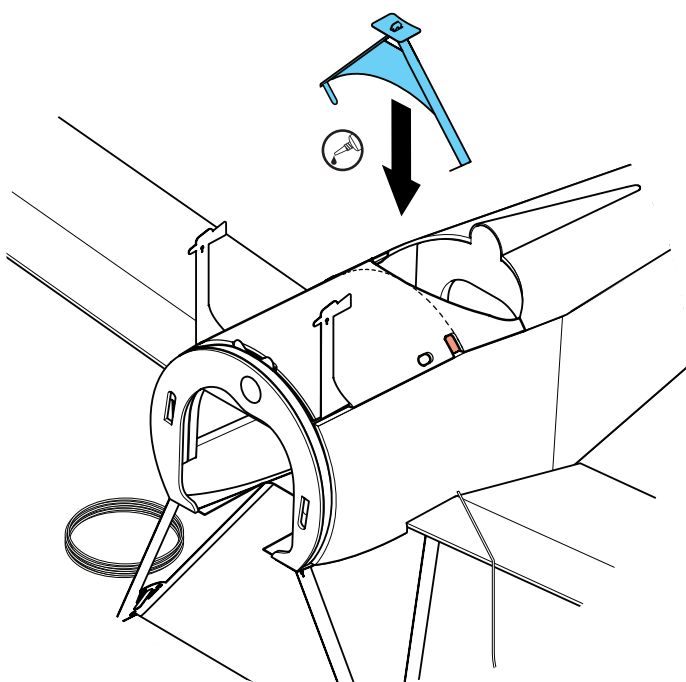
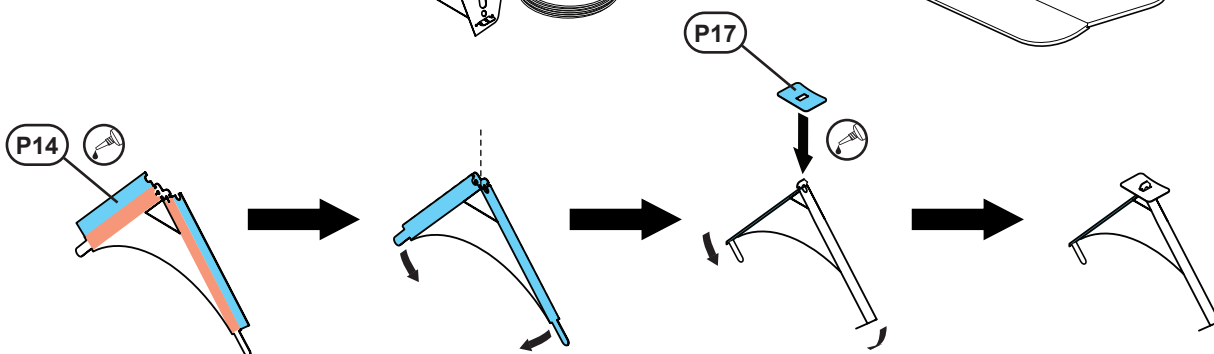
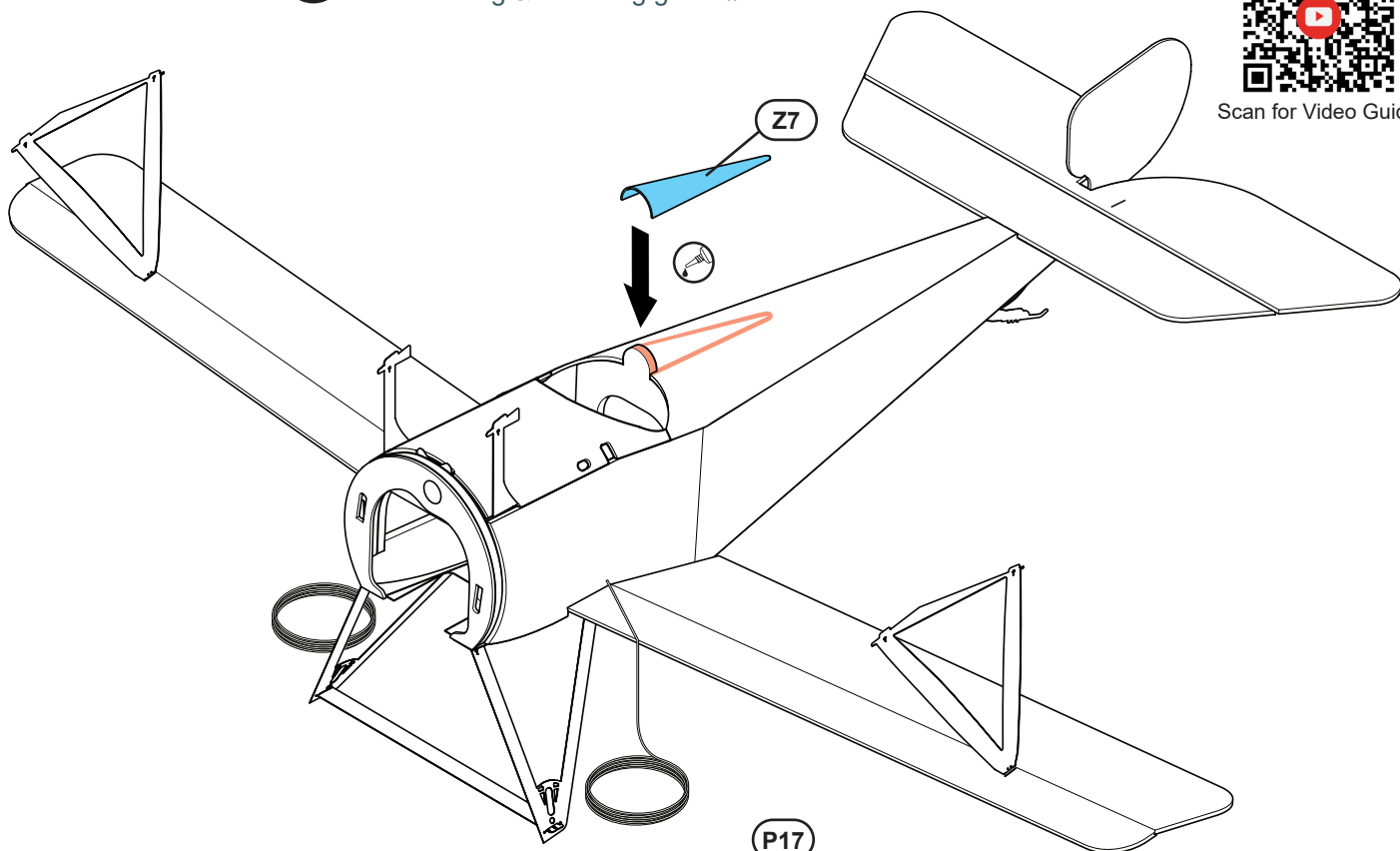

STAGE 8 UPPER WING



Scan for Video Guide

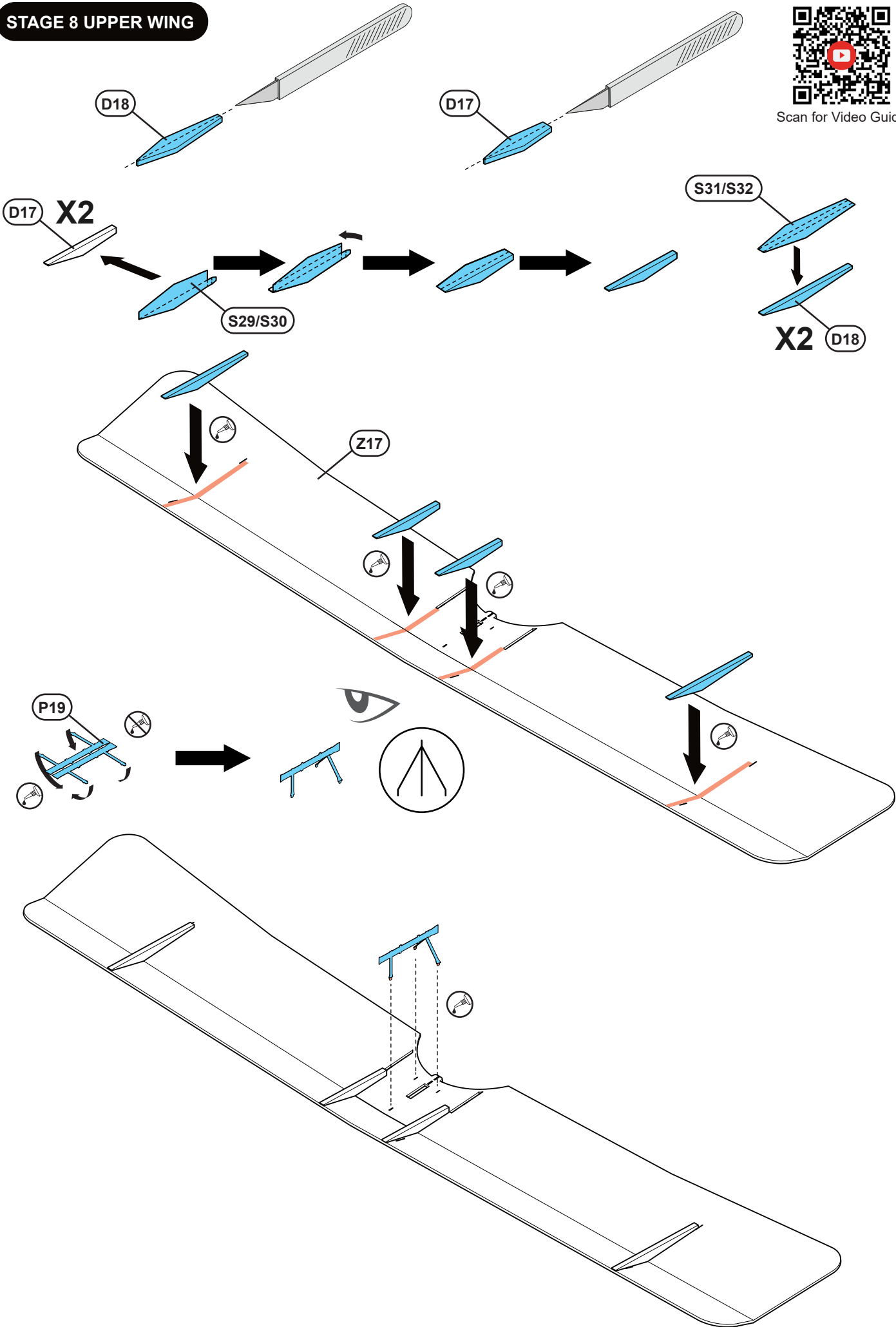

STAGE 9 RIGGING



Scan for Video Guide



Rig the aircraft loosely until the top wing is attached. Only tension after the top wing is in place.

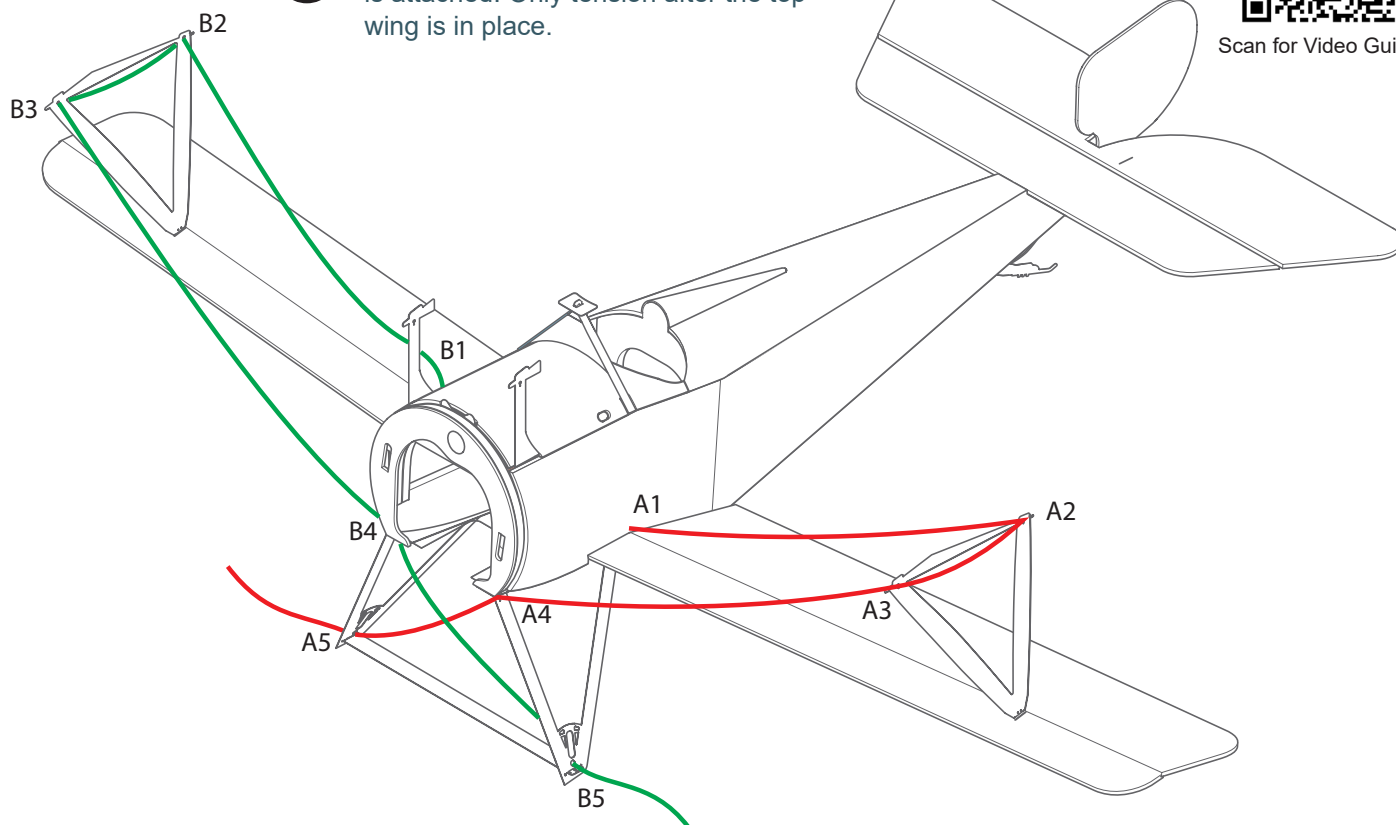

Rig the aircraft loosely until the top wing is attached. Only tension after the top wing is in place.

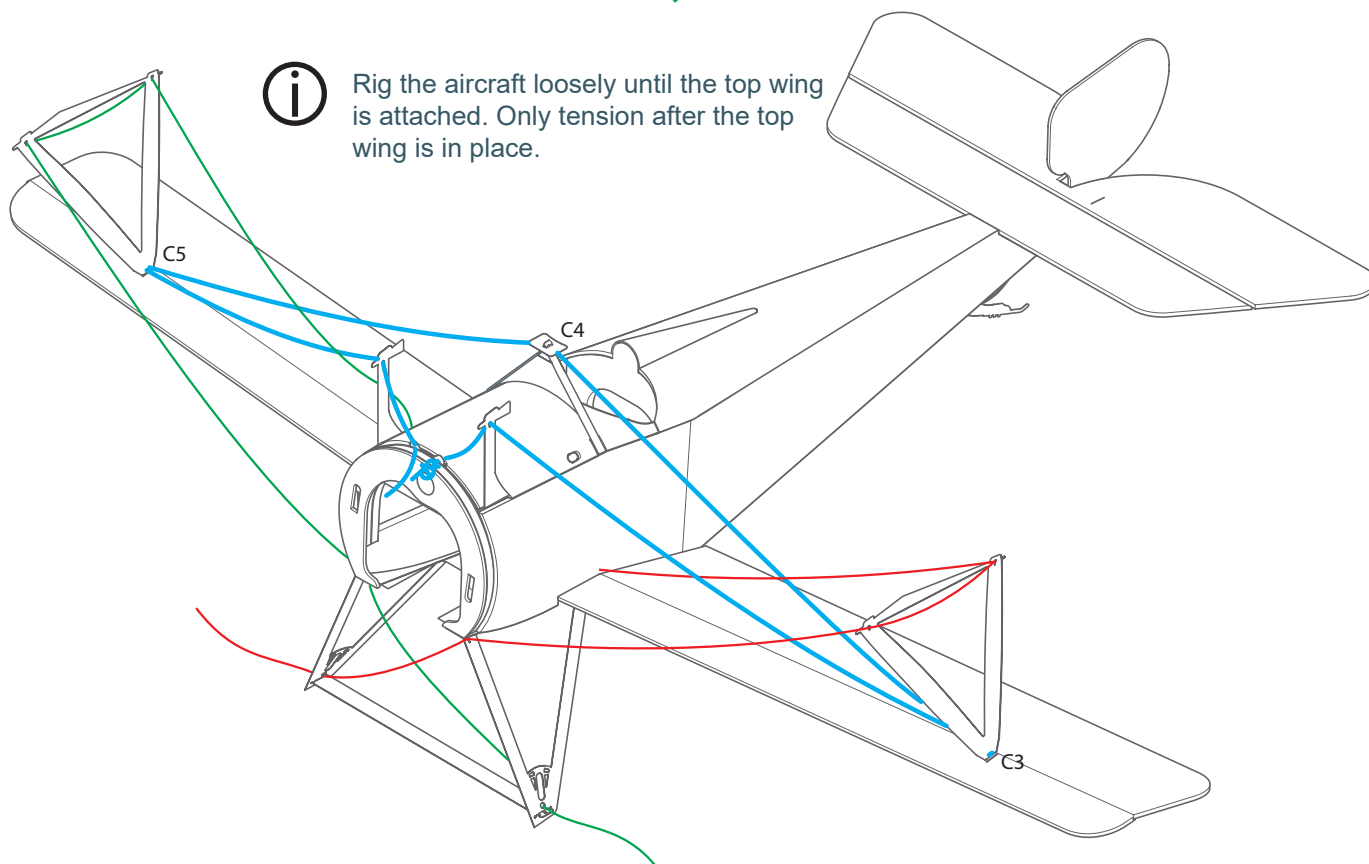

STAGE 10 MOUNTING WING



Ensure the tabs on the top of the strutwork insert fully into the corresponding slots in the wing. Secure and allow adhesive to set.



Dry fit before gluing



Scan for Video Guide

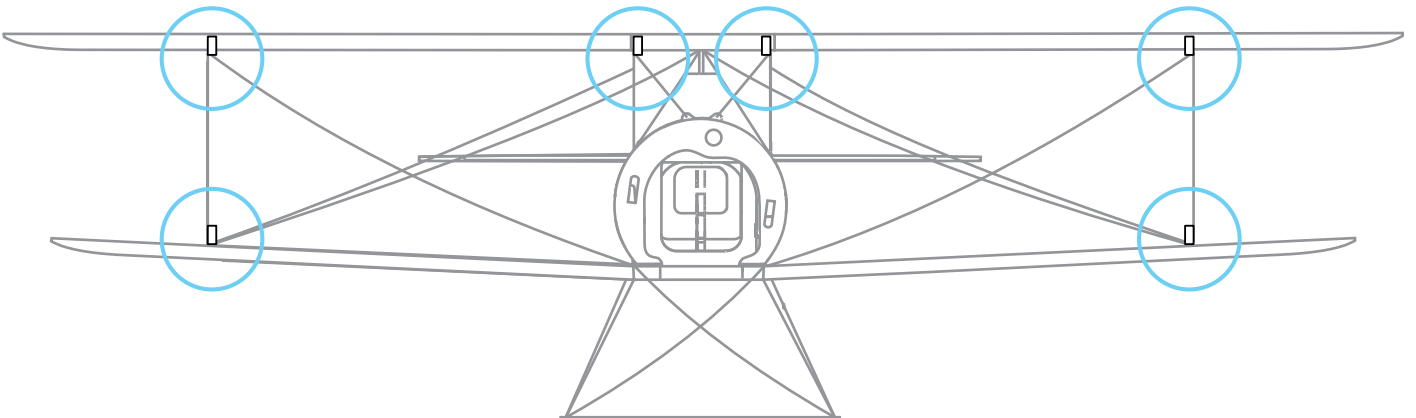
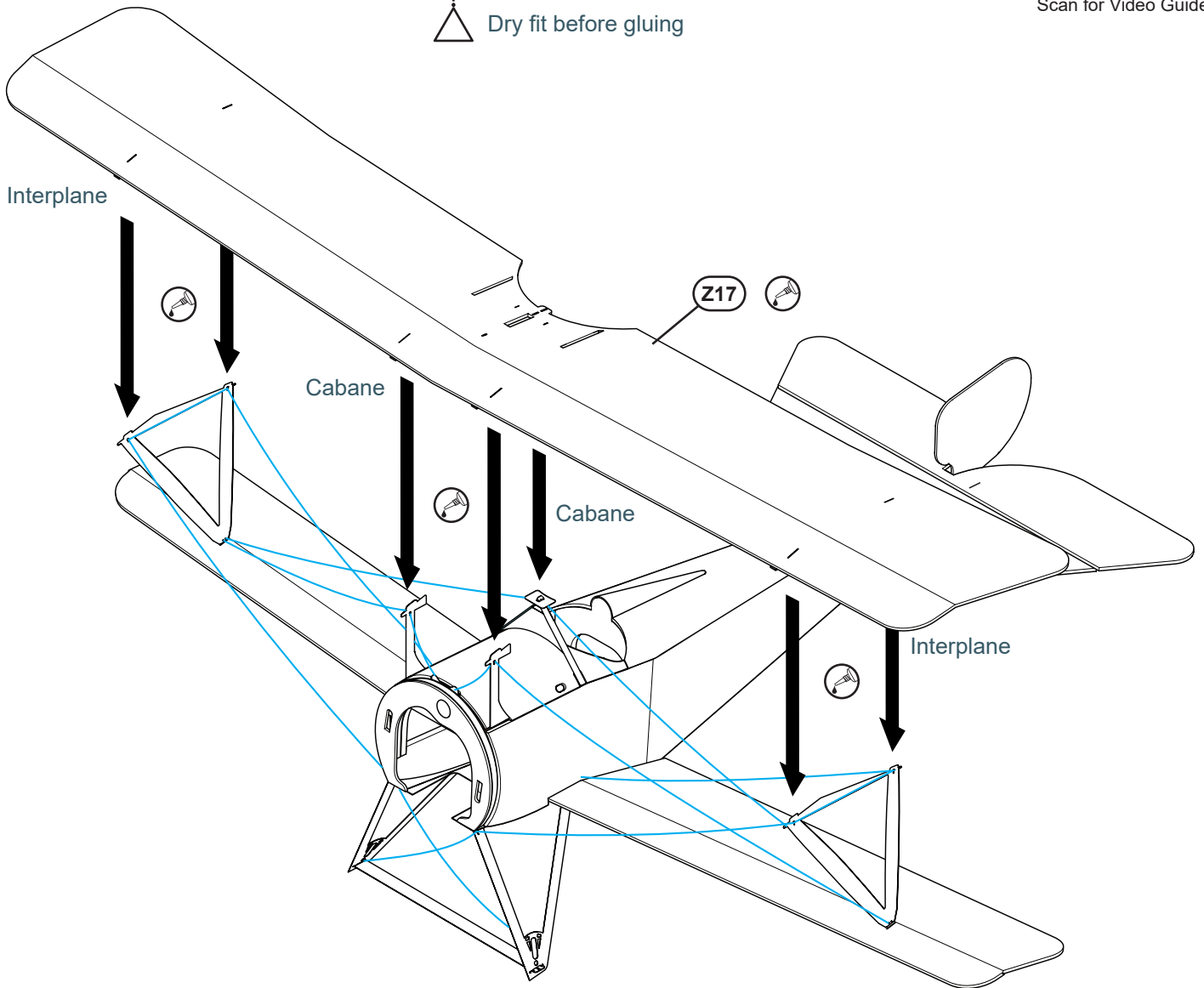



Scan for Video Guide

FRONT VIEW

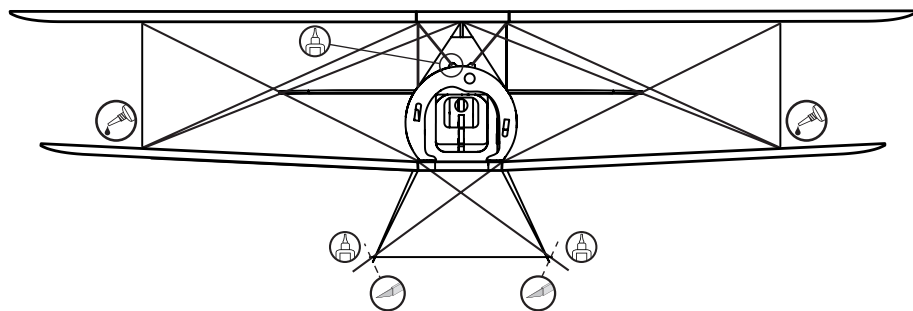
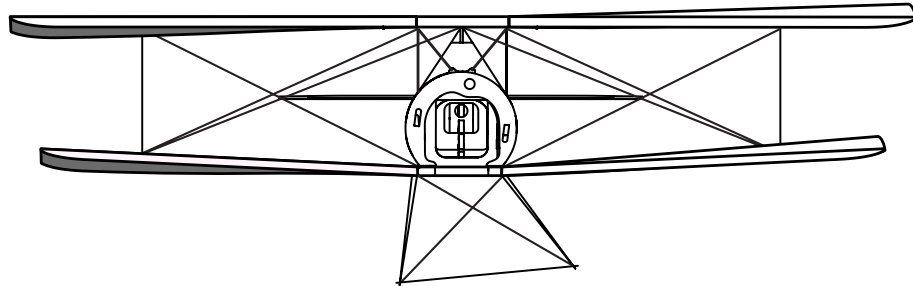
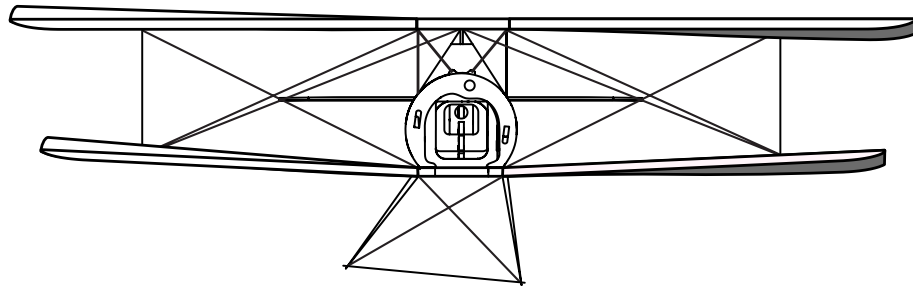

Ensure correct alignment when tensioning the rigging

The rigging on the Nieuport 17 is functional. It strengthens and stabilises the wings to provide predictable flight characteristics so is important to get right!

Tension the wire between struts. Because of the shape of the laser cut holes in the struts, you can lock the thread at each point that it passes through a rigging hole.

Work on tensioning the wire on both sides of the aircraft simultaneously to help maintain symmetry. Secure the end points of the rigging to the underside of the wing once happy with the tension using foam safe CA or Aliphatic resin.

Check alignment visually then add a small amount of adhesive to each point where the rigging passes through strut work.

Trim excess rigging with a fresh blade.

Glue bottom of both Interplane struts to lower wing ribs.

STAGE 12 MOTOR MOUNT



Scan for Video Guide

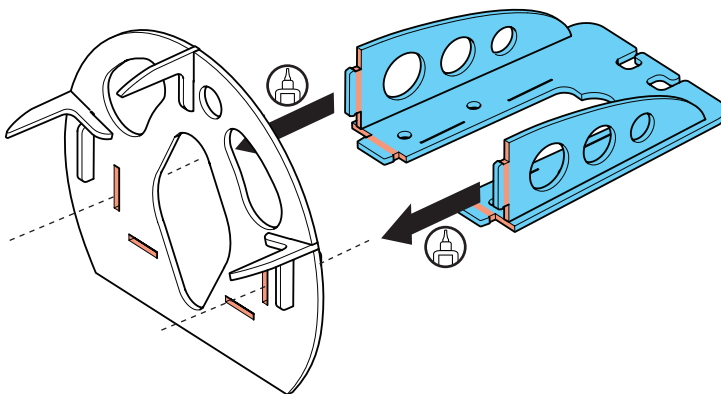
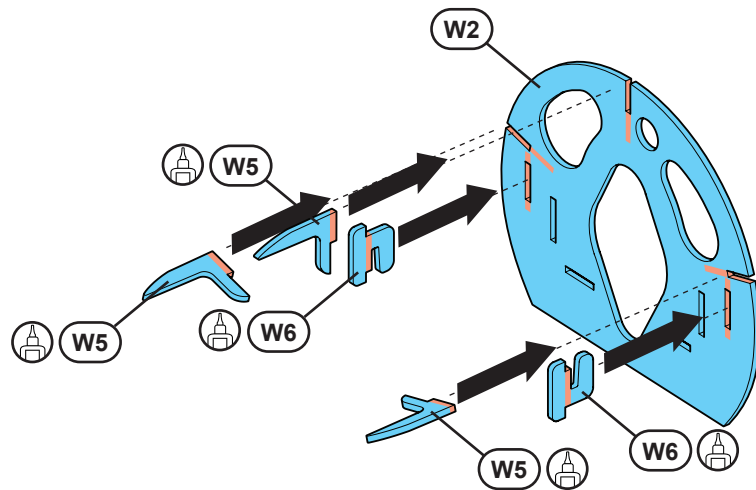
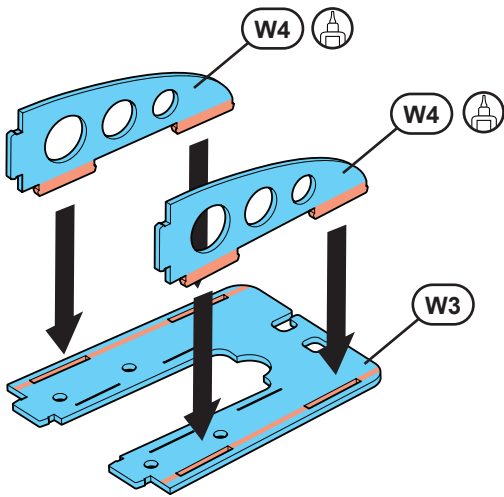

Ensure the magnet is correctly oriented before installation. Do this by matching it to the magnet installed in the fuselage firewall before installing it here.

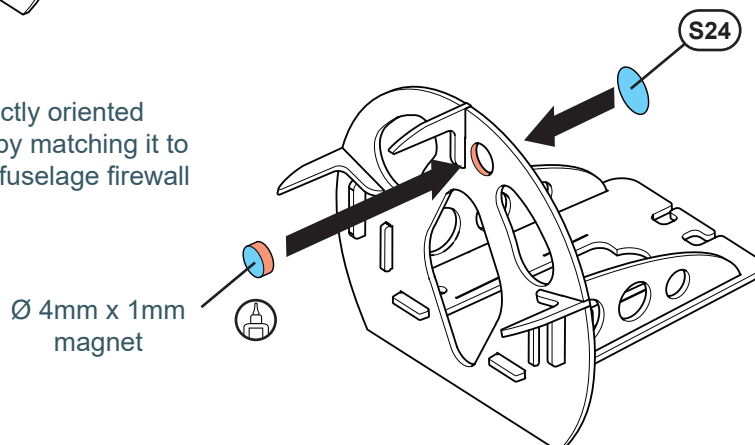

STAGE 13 ROTARY ENGINE



Scan for Video Guide

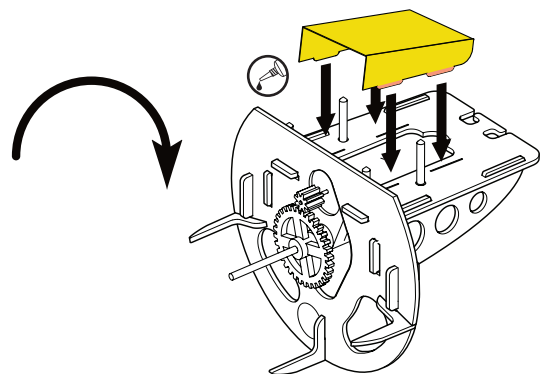
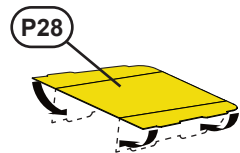
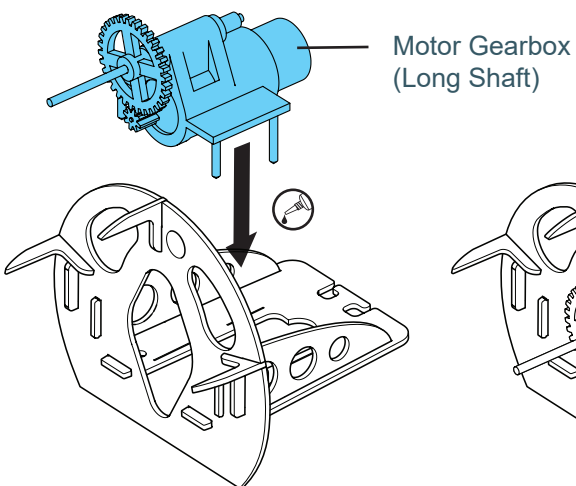
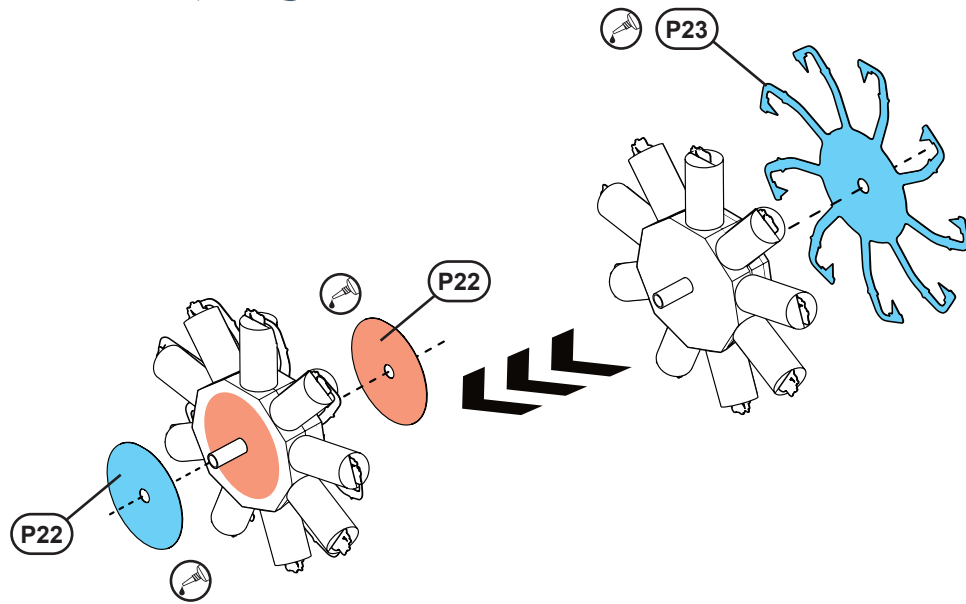
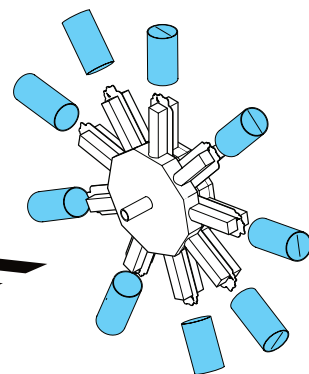
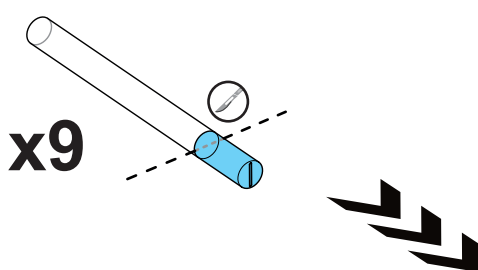
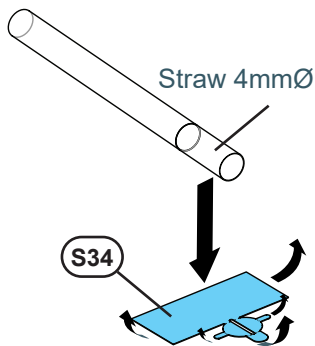
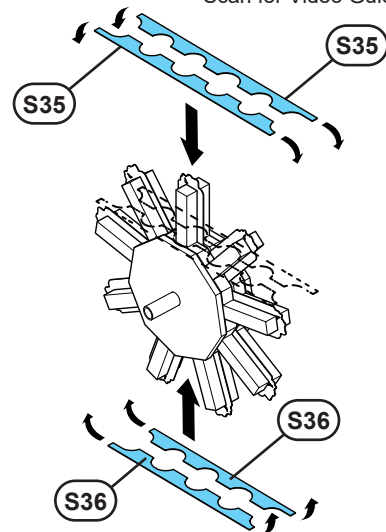
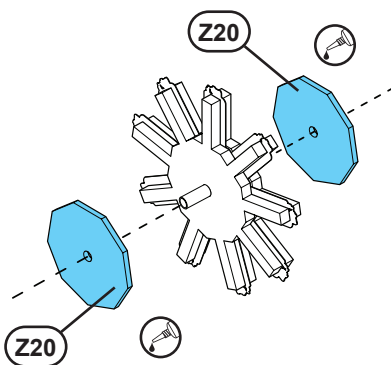
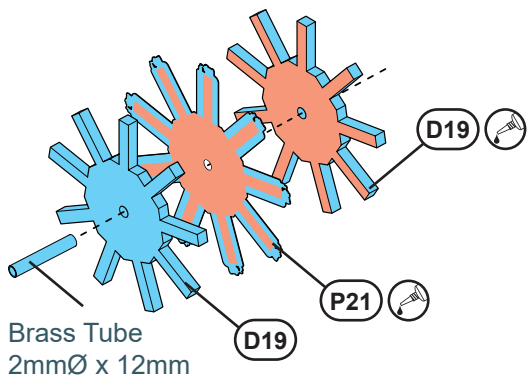

STAGE 14 COWL

Vac Formed Plastic Cowl

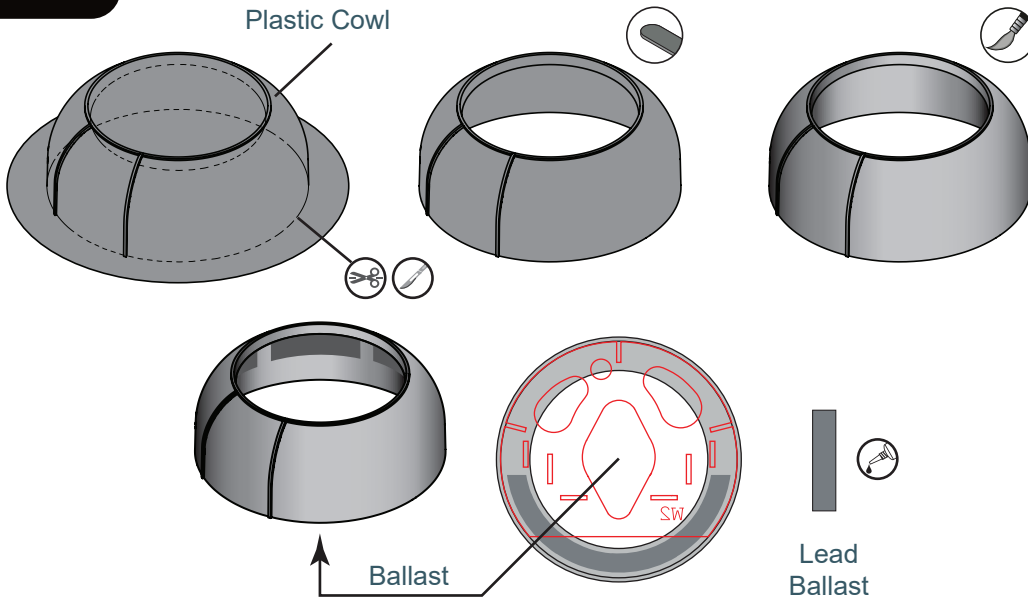

Scan for Video Guide

Ballast

Lead Ballast

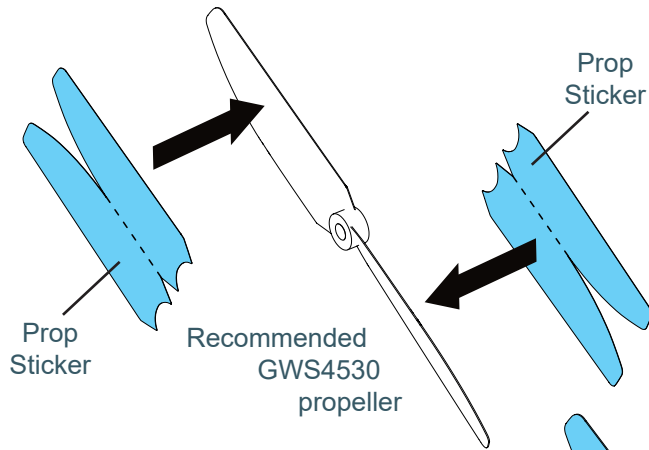

Complex Stickers can be applied by wetting the adhesive side to aid positioning

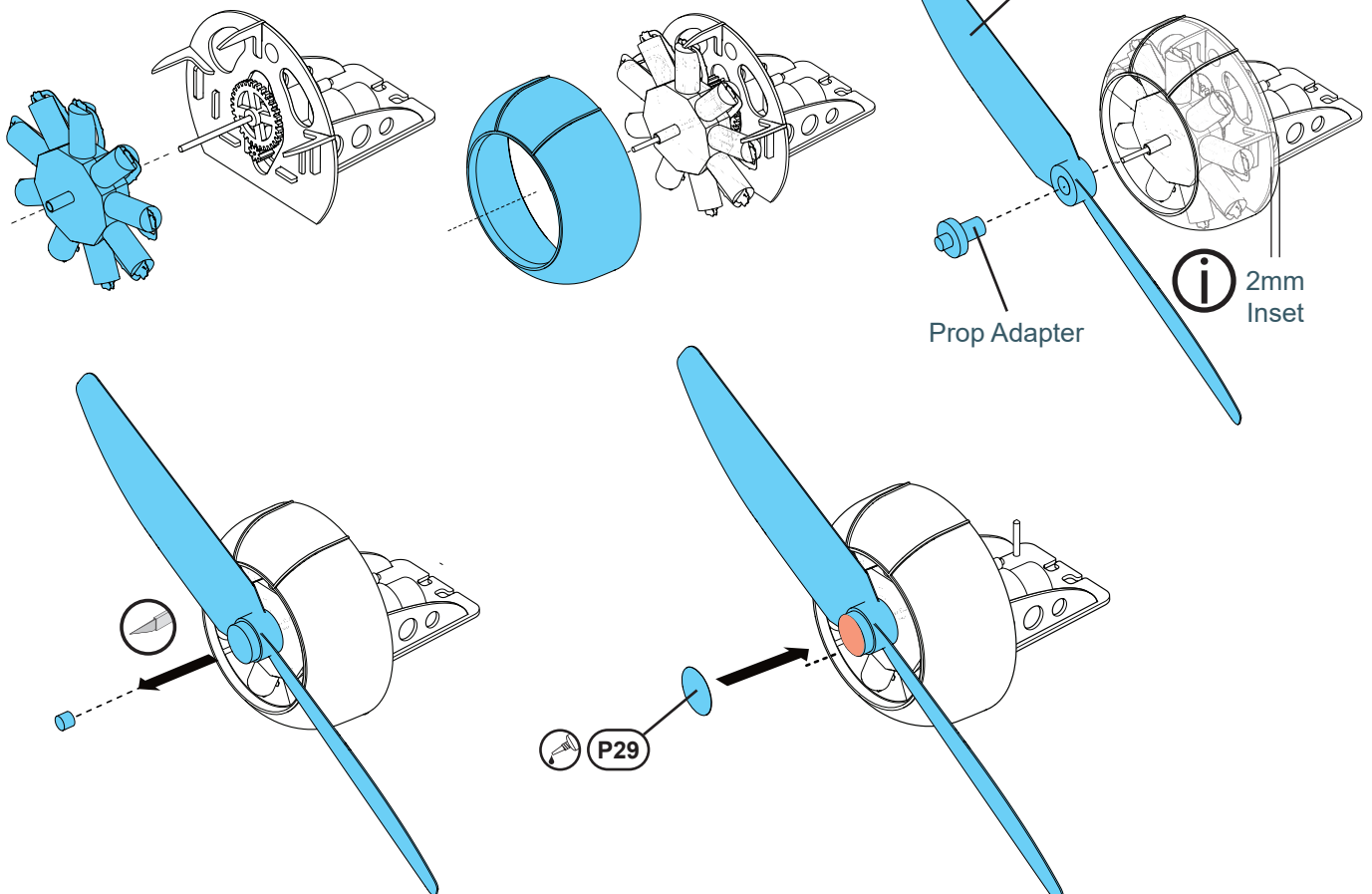

2mm Inset

P29

STAGE 15 WHEEL ASSEMBLY



Scan for Video Guide

i Bevel & Score Z14 before installation - See Scoring & Beveling guide #2

i Assemble each wheel onto the axle temporarily to ensure good alignment.

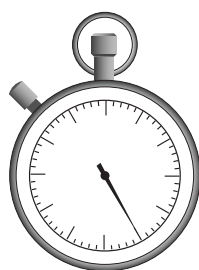
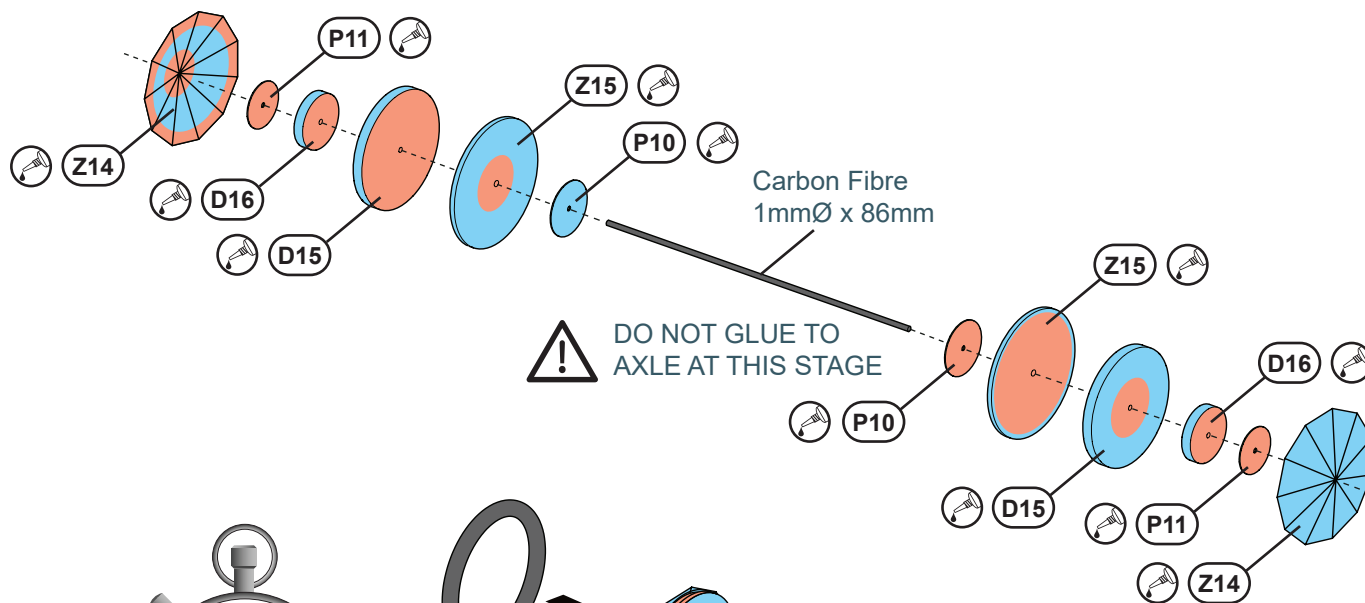

Time
2 Hour

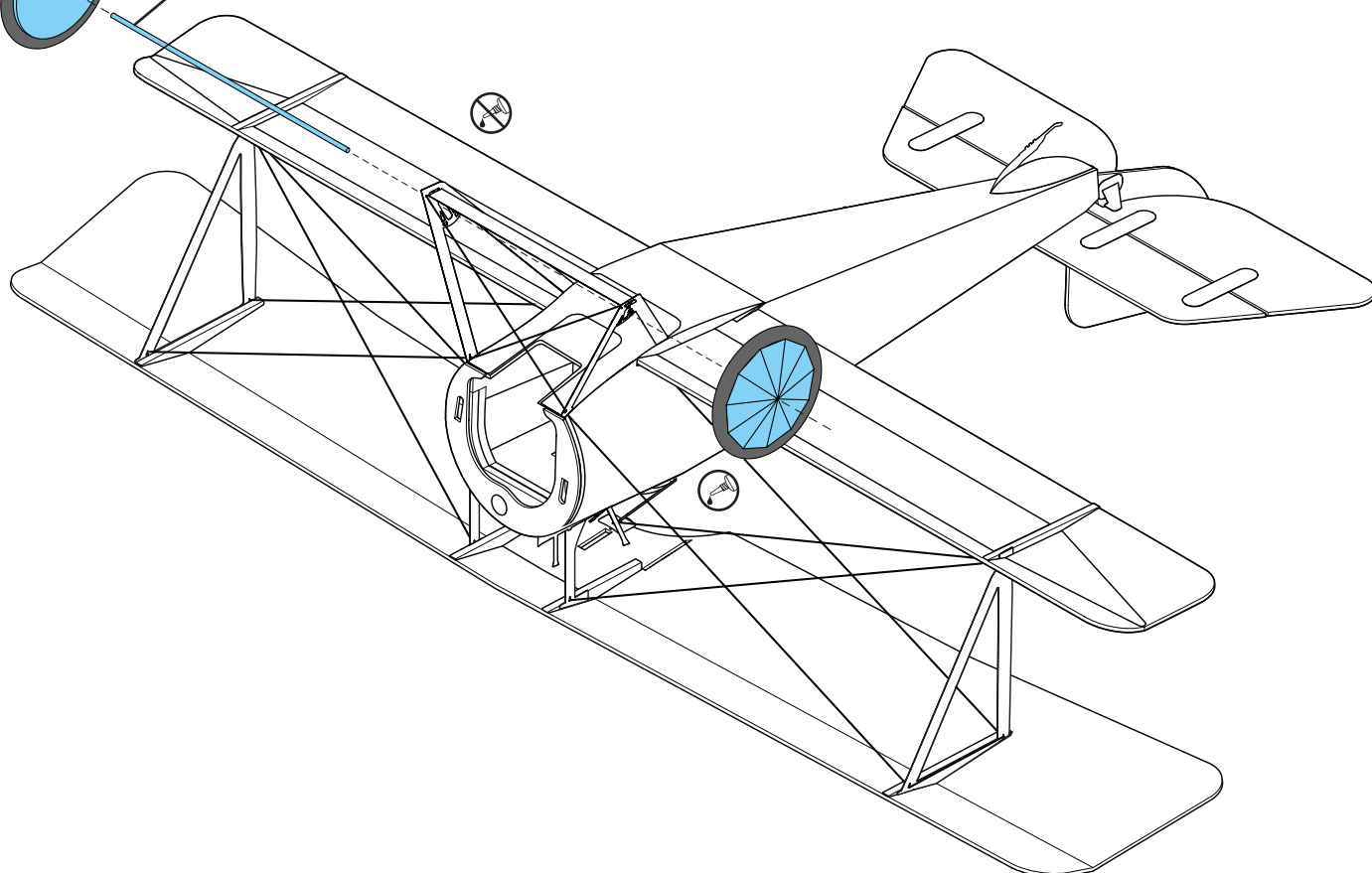
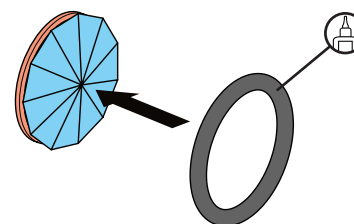
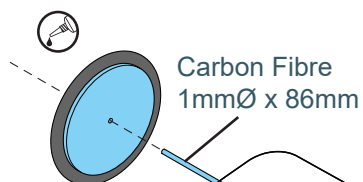

STAGE 16 ELECTRONICS



Ensure receiver servos are centered before installing. To do this, bind to transmitter and center trims on Elevator, Ailerons & Rudder (on transmitter).



Scan for Video Guide

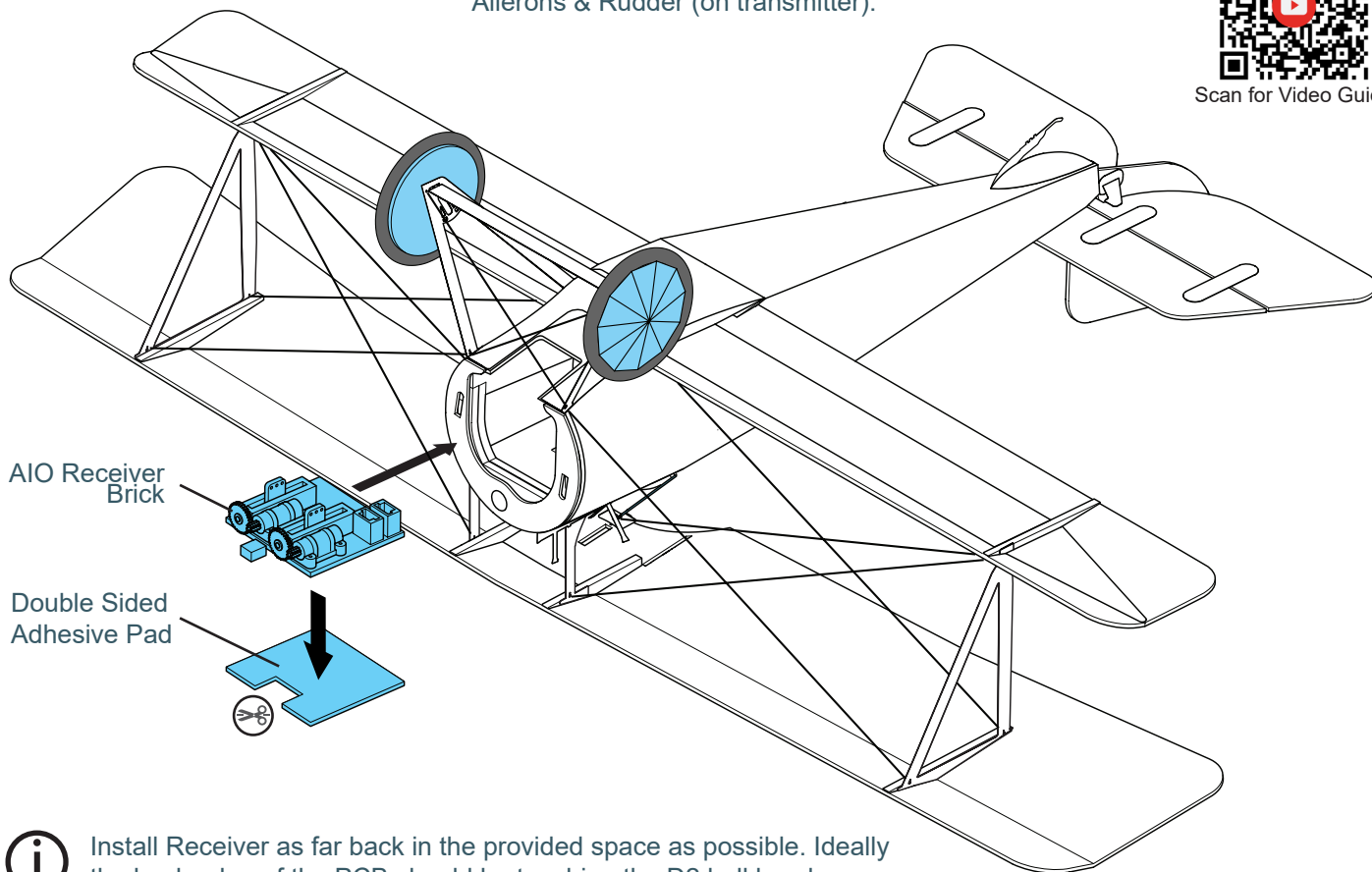

Install Receiver as far back in the provided space as possible. Ideally the back edge of the PCB should be touching the D2 bulkhead.

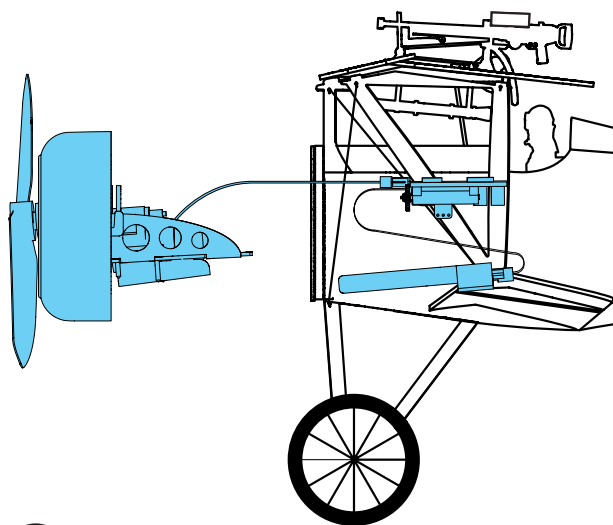

Correct position of battery

STAGE 17 PILOT

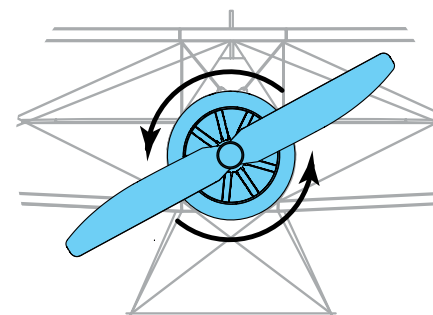
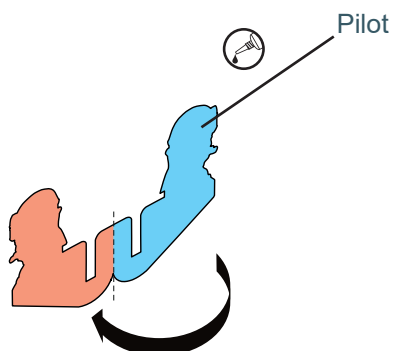

Attach motor assembly by inserting lugs into slots and rotating until magnets align

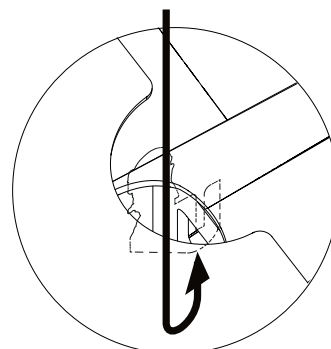

STAGE 18 CONTROL RODS



Insert individual control wire from the rear and attach to appropriate control horn. Set control surface to neutral then, using slim or needle nose pliers, bend the end of the control wire at the point it will need to attach to the servo arm. Un-hook the control wire from the control horn, pull out of the fuselage and complete the hook bend for the servo arm. Trim hook to 4mm in length.



Scan for Video Guide

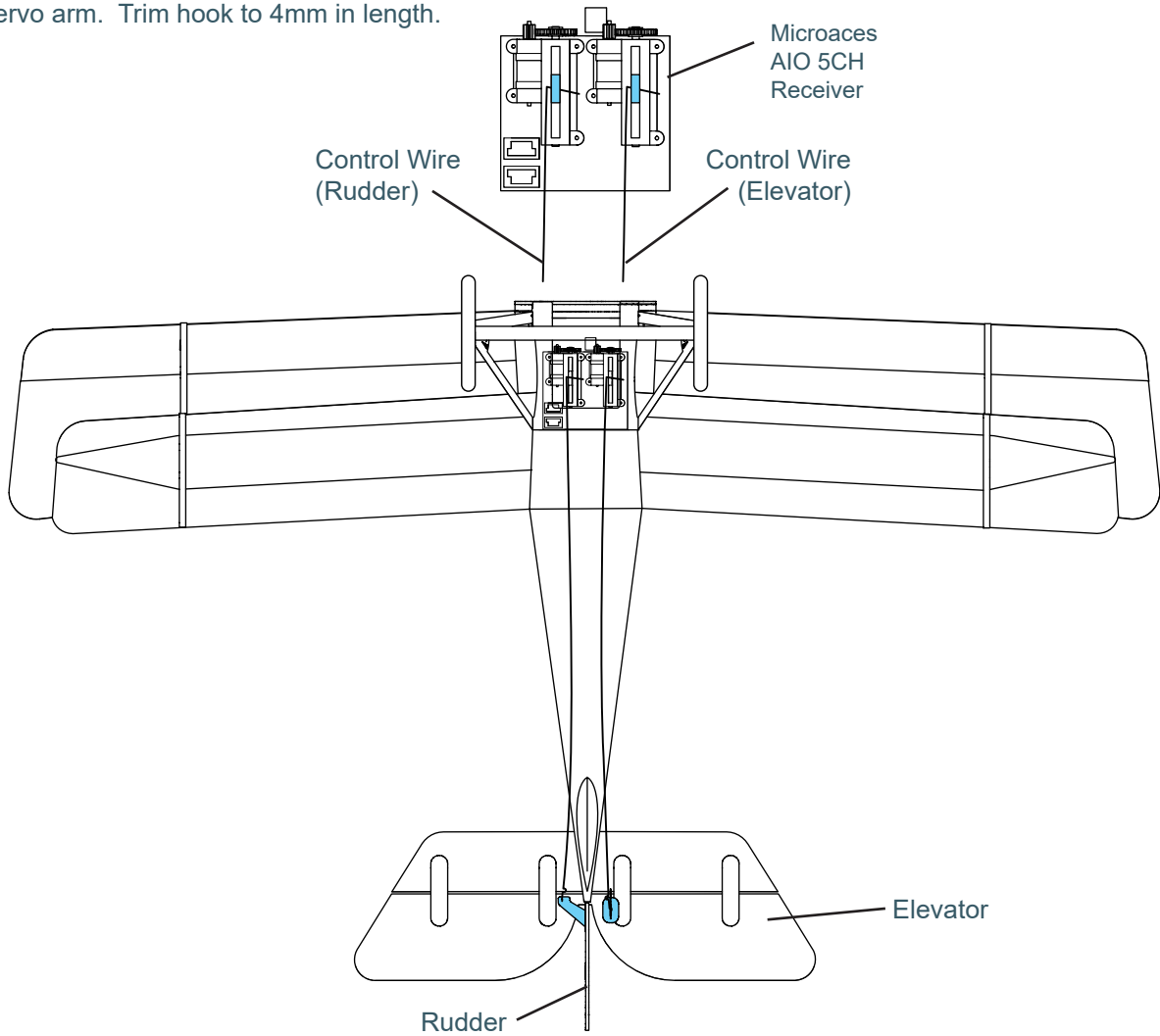

View from Below

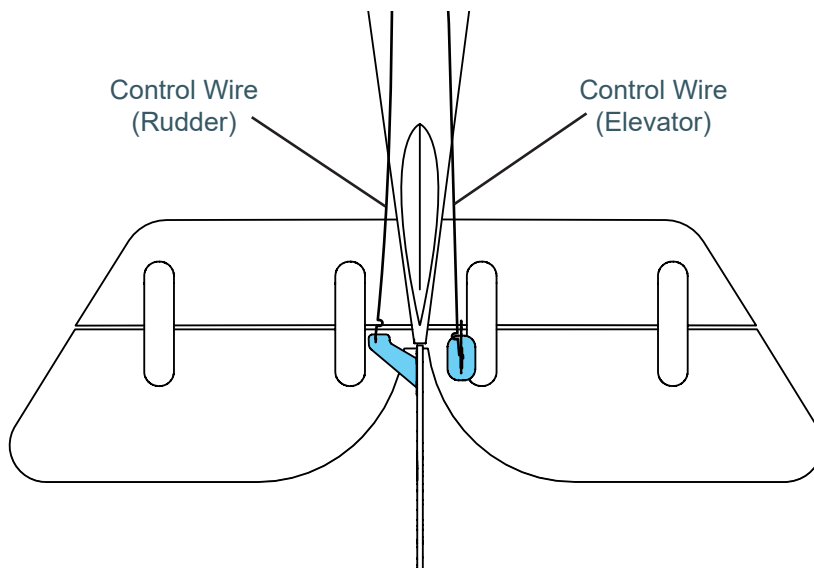

The Control Horns for the rudder and elevator are flexible. Install the control wires for each and use tweezers to bend the horns to insert the 'Z' bend into the hole.

Use the outer hole of the control horns for more gentle control of your aircraft!

STAGE 19 FINISHING TOUCHES



Scan for Video Guide

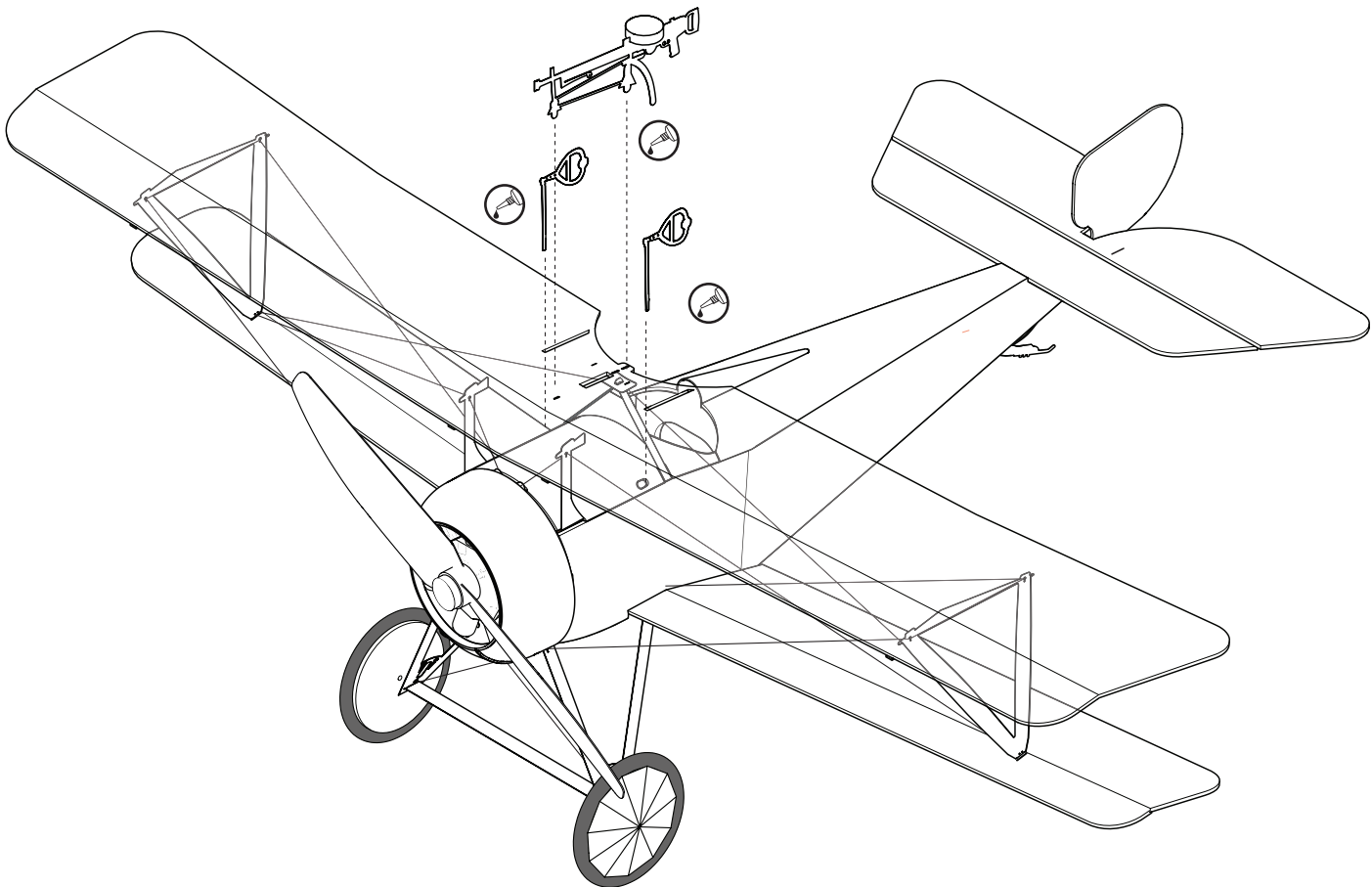
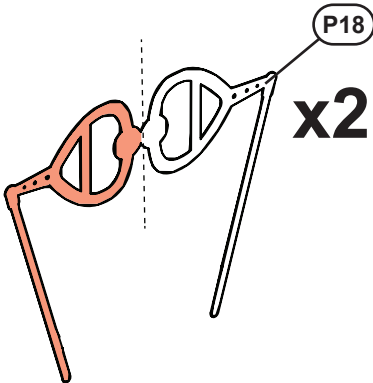
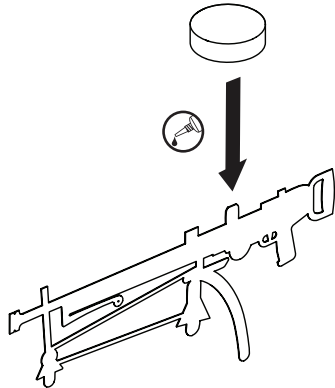
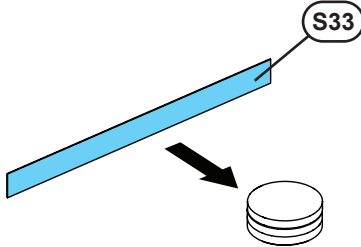
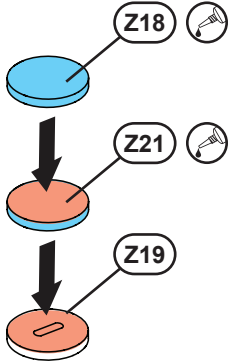
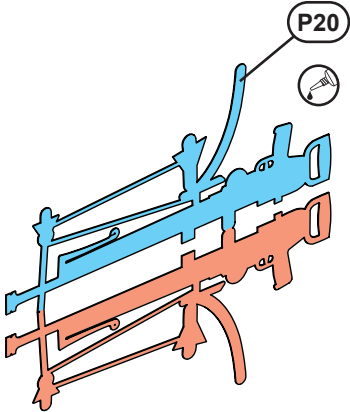

STAGE 20 PREPARATION FOR FLIGHT

Centre of Gravity (CoG)

With all the electronics installed including the battery, the CoG should be around the apex of the top wing as shown on the diagram below.

Balance on finger tips to see if the aircraft balances at this point. Before adding any weight it is advisable to perform a glide test. Add weight accordingly to obtain a smooth glide.

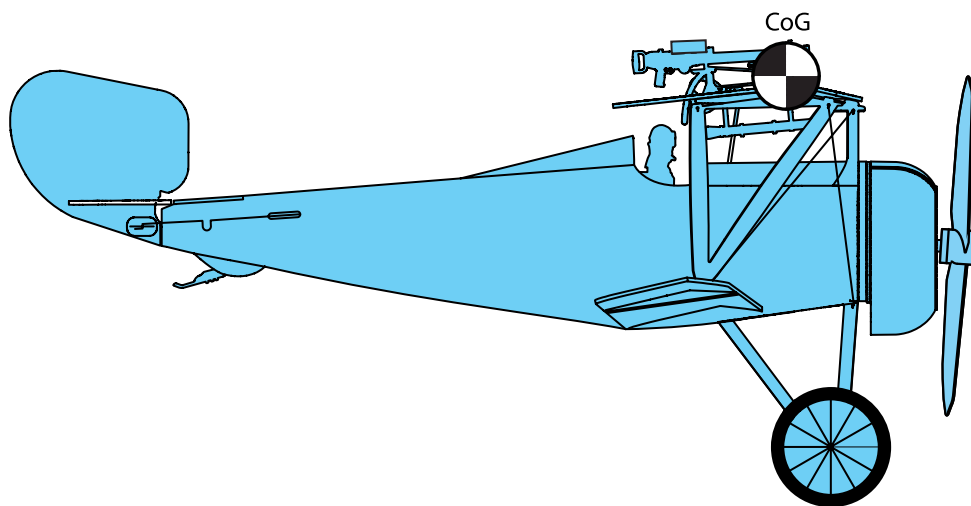

Glide Test - How to!

Find a suitable test space with a forgiving landing area, e.g. over long grass or onto soft furnishing. Ensure all control surfaces are in the neutral position. Gently toss the model straight and level. Observe the results and add balancing weight if required.

*Tail Heavy
Add weight to Nose!*

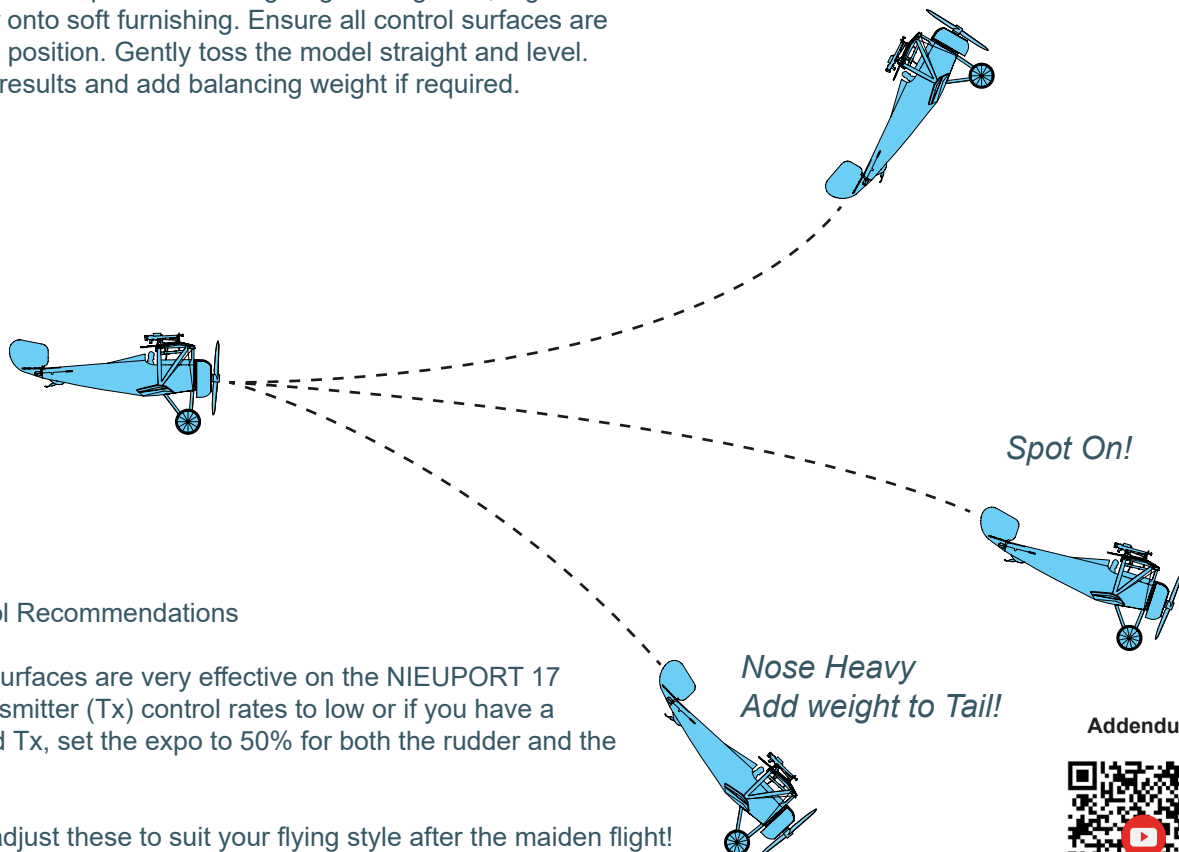

Radio Control Recommendations

The control surfaces are very effective on the NIEUPORT 17. Set your transmitter (Tx) control rates to low or if you have a computerised Tx, set the expo to 50% for both the rudder and the elevator.

Feel free to adjust these to suit your flying style after the maiden flight!

*Nose Heavy
Add weight to Tail!*

Addendum



Scan for Video Guide
Ball's Spinner