

1. Door Prep

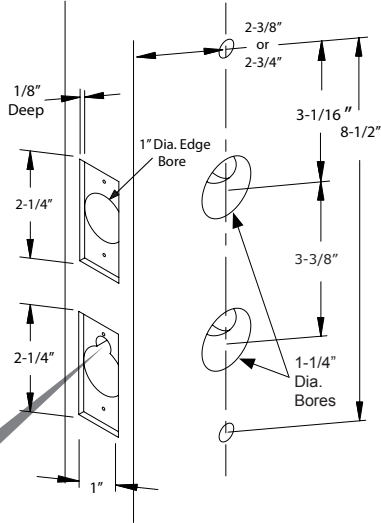

Important:
3/8" to be drilled before 1" bore.

See template for door prep specifications.

2. Door Jamb Prep

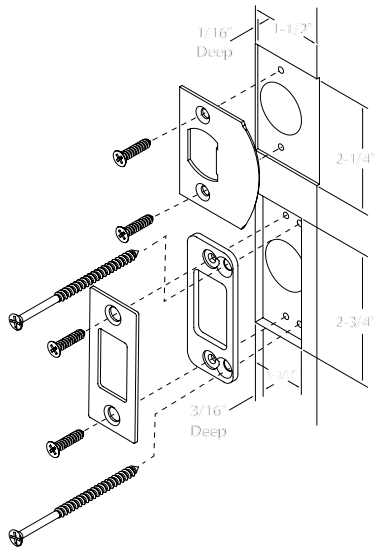

3. Install Latch & Deadbolt

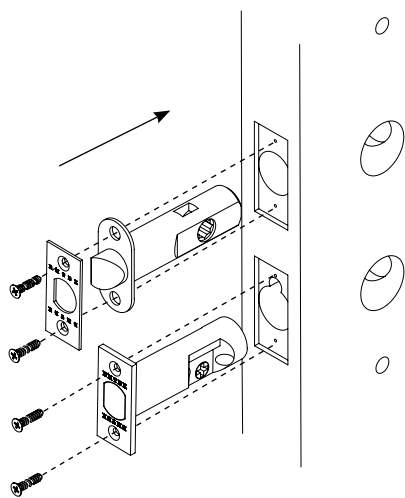

4. Outside Installation

Step 1. Position the outside trim through the bore hole.

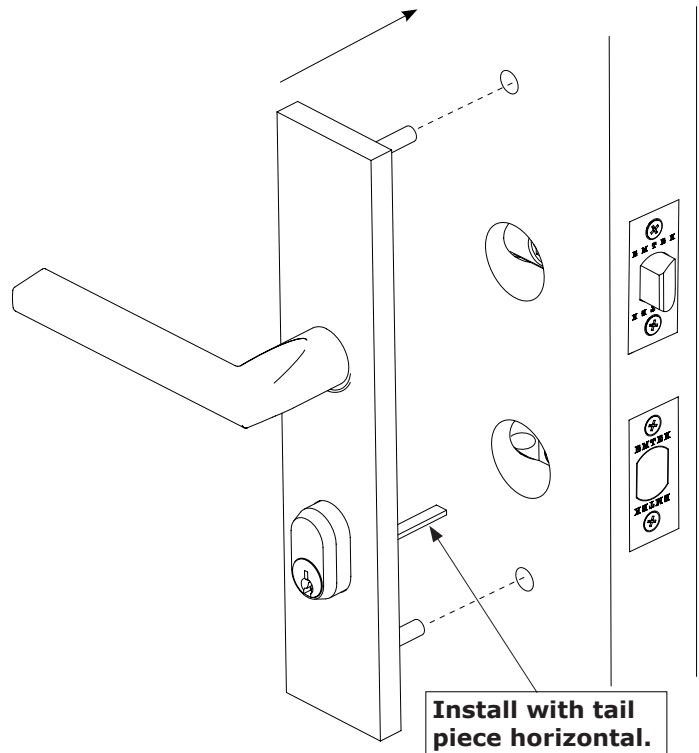

5. Inside Installation

Step 2. Fasten Inside Trim using two #8 machine screws (provided).

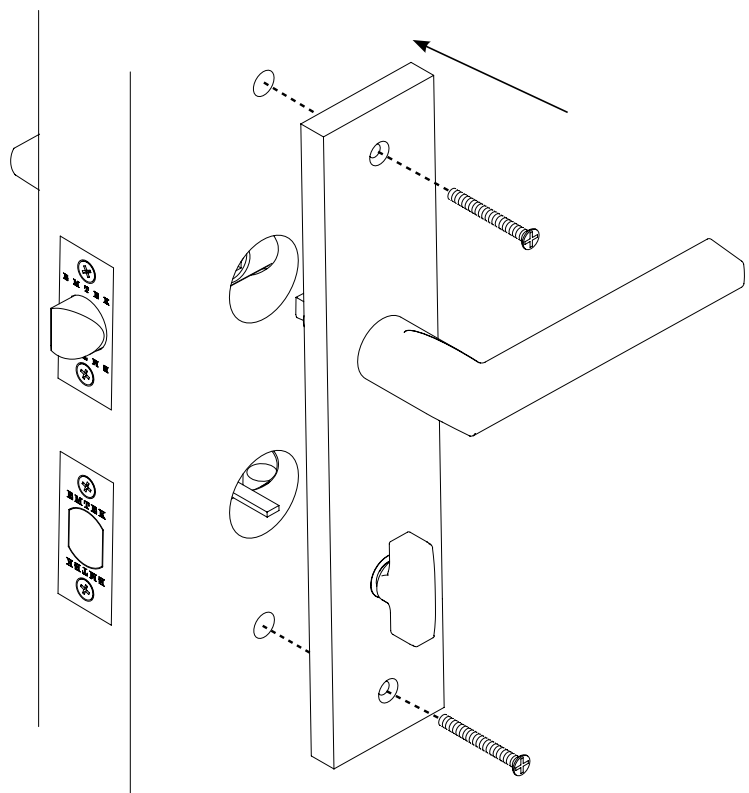

1. Door Prep

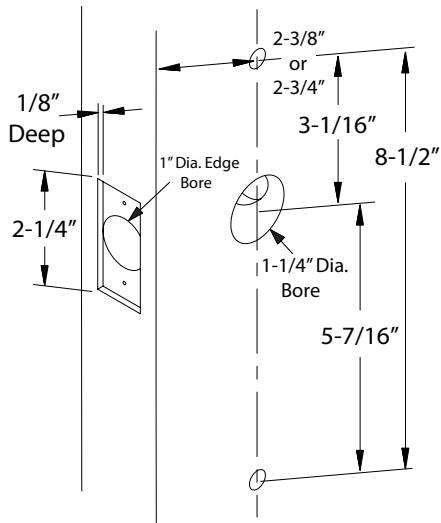

See template for door prep specifications.

2. Door Jamb Prep

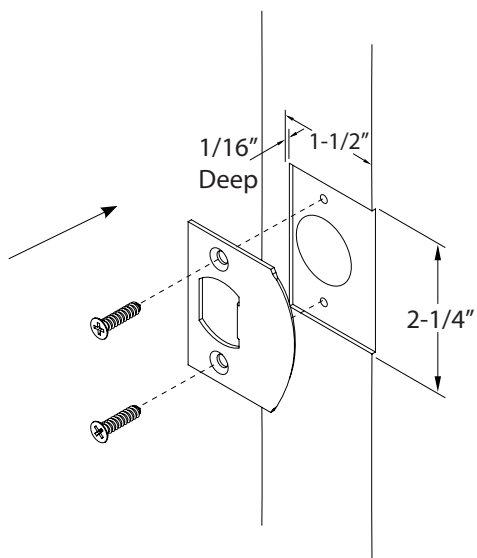

3. Install Latch

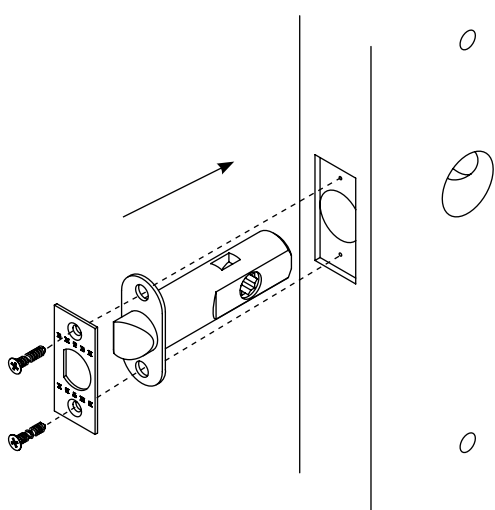

4. Outside Installation

Step 1. Position the outside trim through the bore hole.

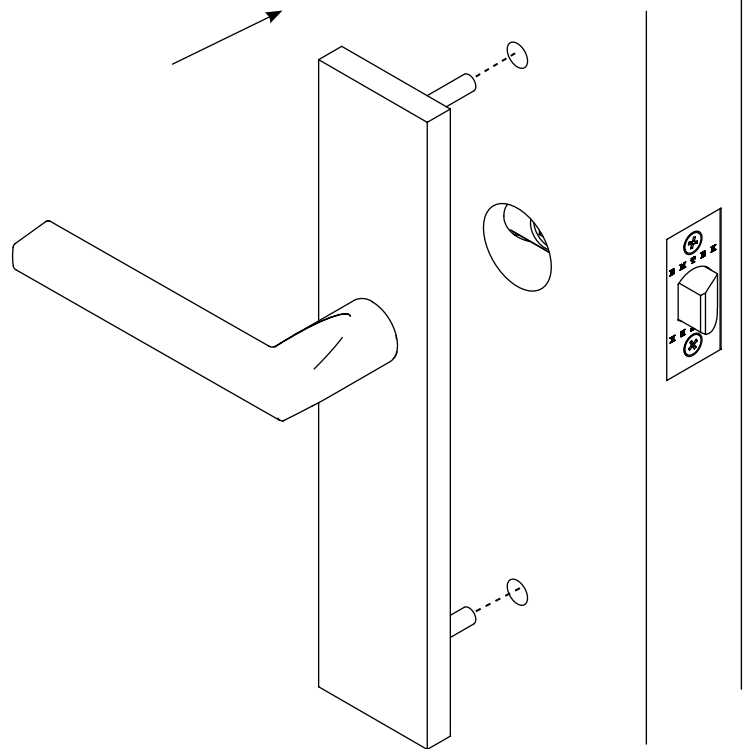

5. Inside Installation

Step 2. Fasten Inside Trim using two #8 machine screws (provided).

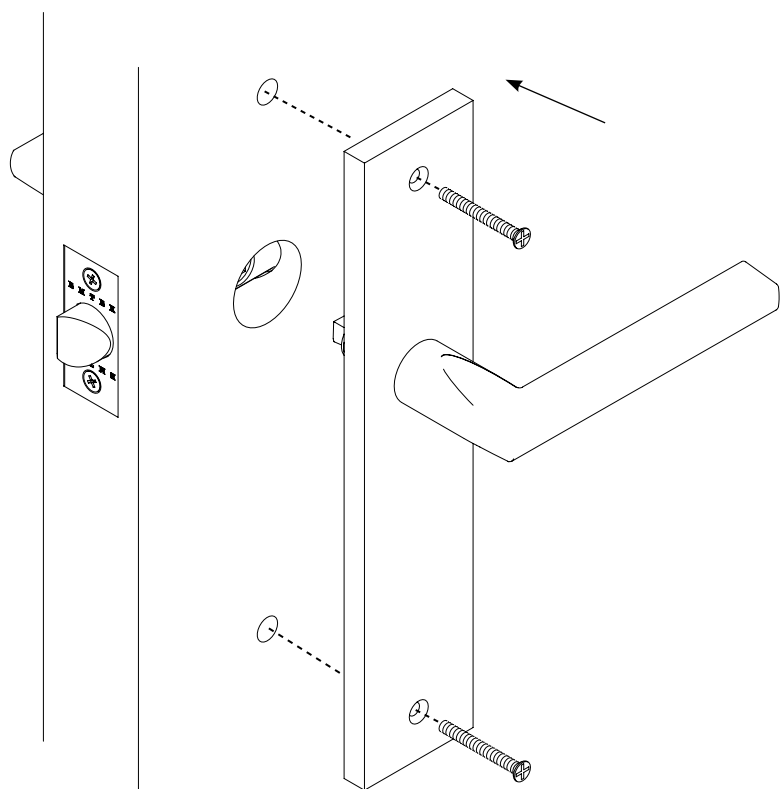

1. Door Prep

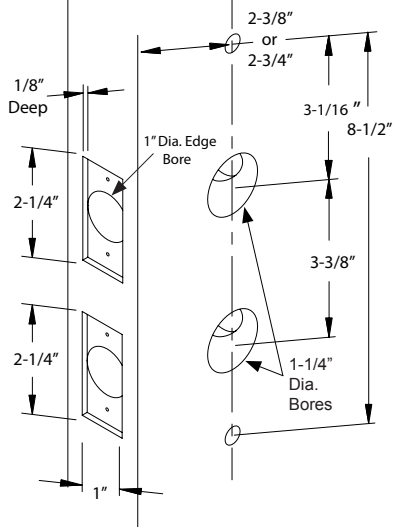

See template for door prep specifications.

2. Door Jamb Prep

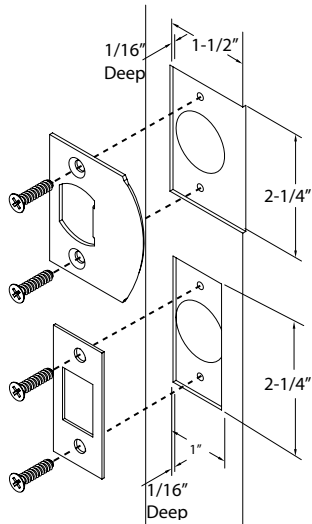

3. Install Latch & Dead Bolt

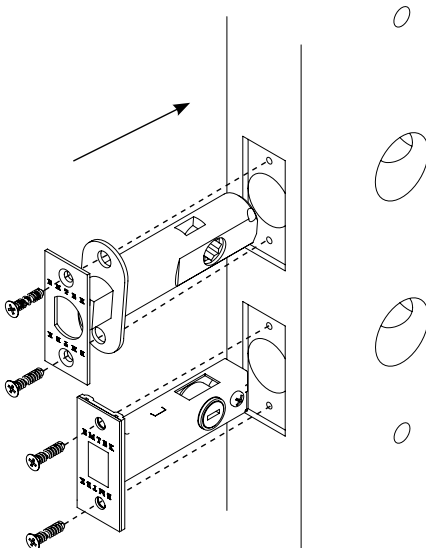

4. Outside Installation.

Step 1. Position the outside trim through the bore hole.

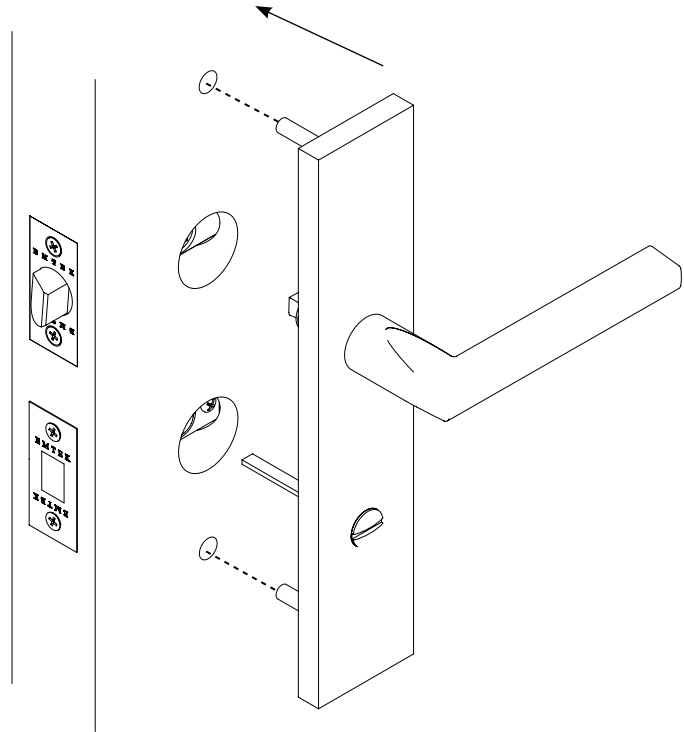

5. Inside Installation

Step 2. Fasten Inside Trim using two #8 machine screws (provided).

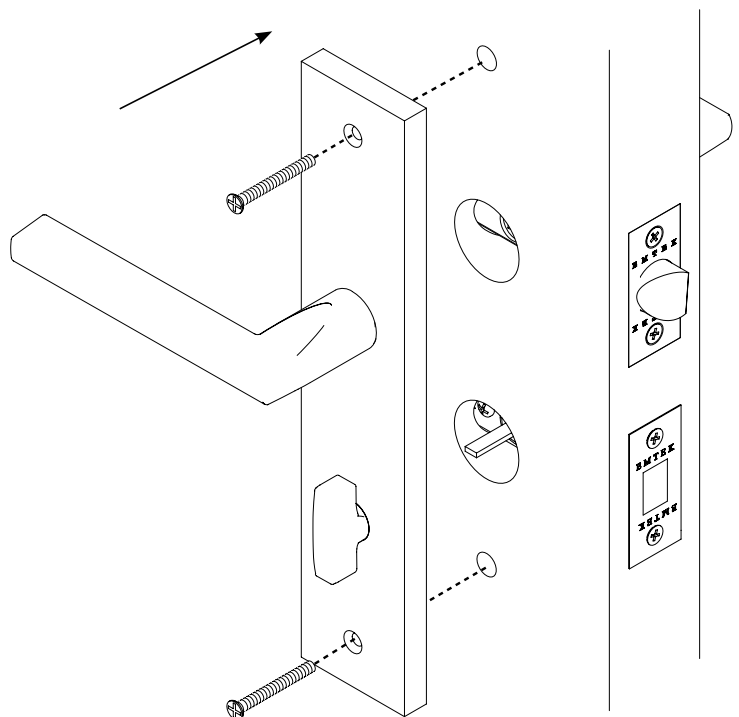

Installation Guide - Narrow Style Dummy Sideplates (Pair)

1. Door Prep For Pair Dummy

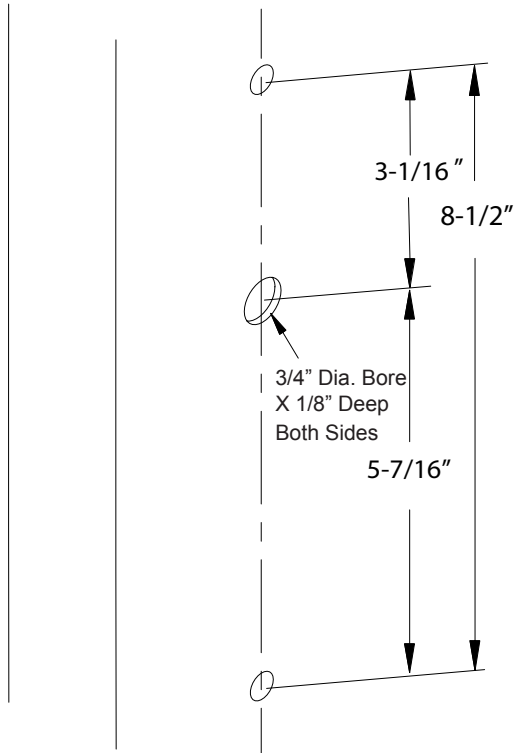

See template for door prep specifications.

2. Pair Dummy Installation

Step 1. Position trim through the bore holes and tighten with #8 machine screws (provided).

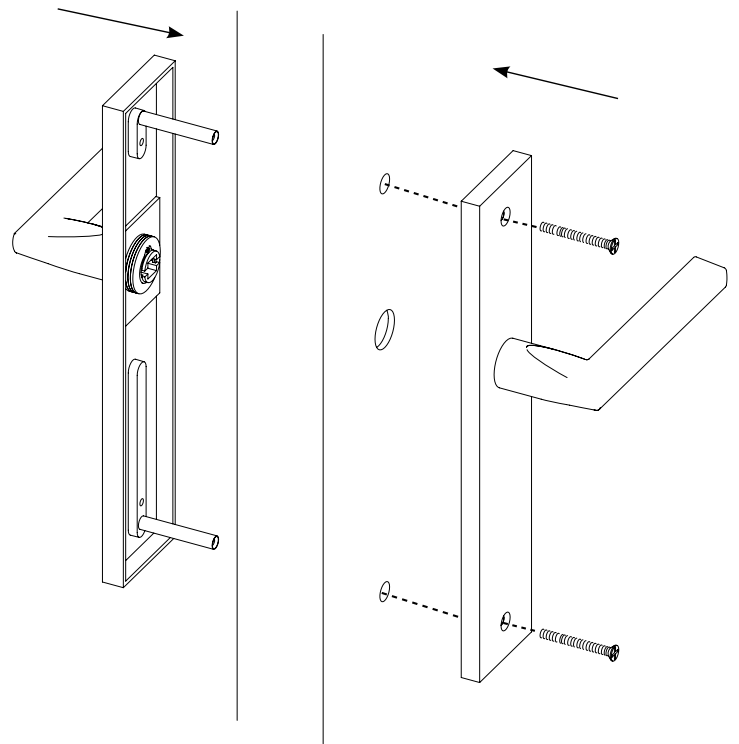

Installation Guide - Narrow Style Dummy Sideplate (Single Sided)

1. Door Prep For Single Sided Dummy

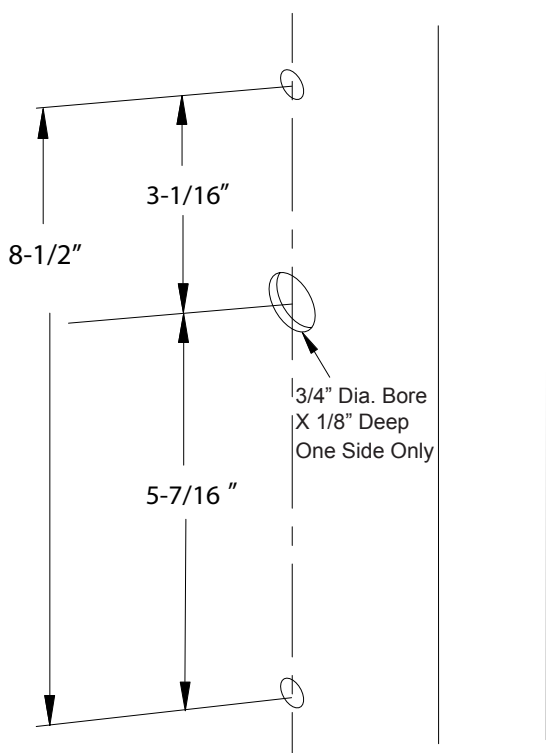

See template for door prep specifications.

2. Single Sided Dummy Installation

Step 1. Position trim through the bore holes and tighten with #8 machine screws (provided).

