

HUBBELL-PRO 50A LOCKING PLUGS

KEY FEATURES:

- Screw-less strain relief
- Ratcheting strain relief nut
- Socket head termination screws
- Cable compatible layout
- Stainless steel shroud



DIMENSIONS

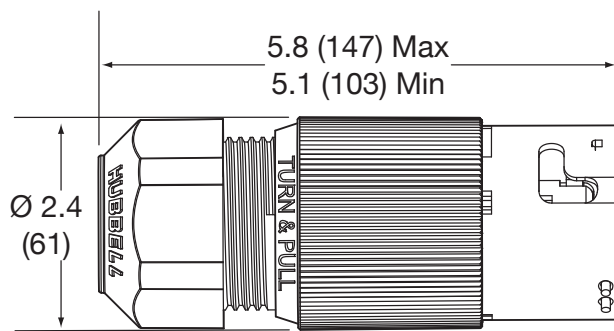

CS6365L

LISTINGS

- UL Standard 498
- CSA Standard C22.2 No. 42
- PSE (CS8365LCR)
- RoHS Compliant

CORD RANGE

- #8 AWG. - #4 AWG
.830 in. - 1.250 in. (21.08 mm - 31.75 mm)

PERFORMANCE

- Flammability: V2 or better
- Operating Temperature:
 - Max. continuous 60°C;
 - Min. -40°C without impact

ENVIRONMENTAL

- NEMA Type 1
- IP20

MATERIALS

Part	Description
Housing	Nylon, black
Assembly Screws	Steel, Zinc
Terminal Screw	Steel, Tin Plate
Terminal Box	Aluminum, Tin Plate
Blades	Brass

ACCESSORIES

- Boot **HBL7716L**

Config.	Rating	Pole/Wire	Catalog Number
	50A 125/250V AC	3P 4W Grounding	CS6365L
	50A 3Ø 250V AC	3P 4W Grounding	CS8365L CS8365LCR (Corrosion Resistant)
	50A 250V AC	2P 3W Grounding	CS8265L