

## Protector® Series

## PROTECTOR® SERIES Standby Generators Liquid-Cooled Gaseous Engine

### INCLUDES:

- Two-Line LCD Multilingual Digital Evolution™ Controller (English/Spanish/French/Portuguese)
- Isochronous Electronic Governor
- Sound Attenuated Enclosure
- Closed Coolant Recovery System
- Smart Battery Charger
- UV/Ozone Resistant Hoses
- Voltage and Frequency Regulation Designed for Sensitive Electronics
- 5 Year Limited Warranty
- UL 2200 Listed

### Standby Power Rating

Model RG10090 (Aluminum - Bisque) - 100 kW 60 Hz  
Model RG13090 (Aluminum - Bisque) - 130 kW 60 Hz  
Model RG15090 (Aluminum - Bisque) - 150 kW 60 Hz



\*Assembled in the USA using domestic and foreign parts

QUIET-TEST



Meets EPA Emission Regulations  
CA / MA Emission Compliant

## FEATURES

- **INNOVATIVE DESIGN & PROTOTYPE TESTING** are key components of GENERAC'S success in "IMPROVING POWER BY DESIGN." But it doesn't stop there. Total commitment to component testing, reliability testing, environmental testing, destruction and life testing, plus testing to applicable CSA, NEMA, EGSA, and other standards, allows you to choose GENERAC POWER SYSTEMS with the confidence that these systems will provide superior performance.
- **TEST CRITERIA:**
  - ✓ **PROTOTYPE TESTED**
  - ✓ **SYSTEM TORSIONAL TESTED**
  - ✓ **NEMA MG1-22 EVALUATION**
  - ✓ **MOTOR STARTING ABILITY**
- **MOBILE LINK® CONNECTIVITY:** Free with select Protector Series standby generator sets, Mobile Link Wi-Fi allows users to monitor the generator set status from anywhere in the world using a smartphone, tablet, or PC. Easily access information such as the current operating status and maintenance alerts. Users can connect an account to an authorized service dealer for fast, friendly, and proactive service. With Mobile Link, users are taken care of before the next power outage.
- **SOLID-STATE, FREQUENCY COMPENSATED VOLTAGE REGULATION.** This state-of-the-art power maximizing regulation system is standard on all Generac models. It provides optimized FAST RESPONSE to changing load conditions and MAXIMUM MOTOR STARTING CAPABILITY by electronically torque-matching the surge loads to the engine.
- **SINGLE SOURCE SERVICE RESPONSE** from Generac's extensive dealer network provides parts and service know-how for the entire unit, from the engine to the smallest electronic component.
- **GENERAC TRANSFER SWITCHES.** Long life and reliability are synonymous with GENERAC POWER SYSTEMS. One reason for this confidence is the GENERAC product line is offered with its own transfer systems and controls for total system compatibility.

### 100 / 130 / 150 kW

#### GENERATOR SPECIFICATIONS

	100 kW	130 / 150 kW
Type	Synchronous	Synchronous
Rotor Insulation Class	H	H
Stator Insulation Class	H	H
Telephone Interference Factor (TIF)	<50	<50
Alternator Output Leads 1-Phase	4 wire	4 wire
Alternator Output Leads 3-Phase	12 wire	12 wire
Bearings	Sealed Ball	Sealed Ball
Coupling	Flexible Disc	Flexible Disc
Excitation System	Synchronous Brushless	Synchronous Brushless
Total Harmonic Distortion	<5%	<5%

#### VOLTAGE REGULATION

Type	Full Digital
Sensing	All
Regulation	Designed for Sensitive Electronics

#### GOVERNOR SPECIFICATIONS

Type	Electronic
Frequency Regulation	Isochronous
Steady State Regulation	Designed for Sensitive Electronics

#### ELECTRICAL SYSTEM

Battery Charger Alternator	40 Amp
Static Battery Charger	2.5 Amp
Recommended Battery (battery included)	Group 31, 925 CCA
System Voltage	12 Volts

#### GENERATOR FEATURES

<p>Revolving field heavy duty generator                      Directly connected to the engine                      Operating temperature rise 135° C above 25° C ambient                      Class H insulation is NEMA rated                      All models fully prototyped tested</p>
--

#### ENCLOSURE FEATURES

Aluminum weather protective enclosure	Ensures protection against mother nature. Electrostatically applied textured epoxy paint for added durability.
Enclosed critical grade muffler	Quiet, critical grade muffler is mounted inside the unit to prevent injuries.
Small, compact, attractive	Makes for an easy, eye appealing installation.
SAE	Sound attenuated enclosure ensures quiet operation.

(All ratings in accordance with BS5514, ISO3046, ISO8528, SAE J1349 and DIN6271)

#### ENGINE SPECIFICATIONS

	100 kW	130 / 150 kW
Make	Generac	Generac
Type	V	V
Cylinders	8	8
Displacement - In <sup>3</sup> (L)	540 (8.86)	540 (8.86)
Bore (in / mm)	4.5 / 114.3	4.5 / 114.3
Stroke (in / mm)	4.25 / 107.95	4.25 / 107.95
Compression Ratio	9.9:1	9.1:1
Intake Air System	Naturally Aspirated	Turbocharged and Aftercooled
Lifter Type	Hydraulic Roller	Hydraulic Roller

#### ENGINE LUBRICATION SYSTEM

Oil Pump Type	Gear
Oil Filter Type	Full Flow Spin-On Cartridge
Crankcase Capacity (qt / L)	10.5 / 9.9

#### ENGINE COOLING SYSTEM

Type	Pressurized Closed
Water Pump	Belt-Driven
Fan Speed (rpm)	2,330
Fan Diameter (in / cm)	22 (55.9)
Fan Mode	Pusher

#### FUEL SYSTEM

Fuel Type	Natural Gas, Propane Vapor
Carburetor	Down Draft
Secondary Fuel Regulator	Standard
Fuel Shut Off Solenoid	Standard
LP Fuel Pressure	11 - 14 in Water Column (100kW) 7 - 11 in Water Column (130 kW and 150 kW)
NG Fuel Pressure	11 - 14 in Water Column (100 kW) 7 - 11 in Water Column (130 kW and 150 kW)

### 100 / 130 / 150 kW

#### GENERATOR OUTPUT VOLTAGE/kW - 60 Hz

		kW LPG	Amp LPG	kW Nat. Gas	Amp Nat. Gas	CB Size (Both)
RG10090	120/240 V, 1Ø, 1.0 pf	96	400	96	400	400
	120/208 V, 3Ø, 0.8 pf	100	347	96	333	400
	120/240 V, 3Ø, 0.8 pf	100	300	96	288	350
	277/480 V, 3Ø, 0.8 pf	100	150	96	144	175
RG13090	120/240 V, 1Ø, 1.0 pf	130	542	130	542	600
	120/208 V, 3Ø, 0.8 pf	130	451	130	451	500
	120/240 V, 3Ø, 0.8 pf	130	391	130	391	400
	277/480 V, 3Ø, 0.8 pf	130	195	130	195	225
RG15090	120/240 V, 1Ø, 1.0 pf	140	583	144	600	700
	120/208 V, 3Ø, 0.8 pf	140	486	150	520	600
	120/240 V, 3Ø, 0.8 pf	140	421	150	451	500
	277/480 V, 3Ø, 0.8 pf	140	210	150	226	250

#### SURGE CAPACITY IN AMPS

		Voltage Dip 30%
RG10090	120 / 240 V, 1Ø	Contact Factory
	120 / 208 V, 3Ø	Contact Factory
	120 / 240 V, 3Ø	Contact Factory
	277 / 480 V, 3Ø	Contact Factory
RG13090	120 / 240 V, 1Ø	Contact Factory
	120 / 208 V, 3Ø	Contact Factory
	120 / 240 V, 3Ø	Contact Factory
	277 / 480 V, 3Ø	Contact Factory
RG15090	120 / 240 V, 1Ø	Contact Factory
	120 / 208 V, 3Ø	Contact Factory
	120 / 240 V, 3Ø	Contact Factory
	277 / 480 V, 3Ø	Contact Factory

#### ENGINE FUEL CONSUMPTION

		Natural Gas		Propane	
		(ft <sup>3</sup> / hr)	(m <sup>3</sup> / hr)	(ft <sup>3</sup> / hr)	(m <sup>3</sup> / hr)
RG10090	25% of rated load	406	11.5	20	0.56
	50% of rated load	655	18.5	294	8.3
	75% of rated load	896	25.4	425	12.0
	100% of rated load	1,128	31.9	528	15.0
RG13090	25% of rated load	635	18	270	7.6
	50% of rated load	1,005	28.4	390	11.0
	75% of rated load	1,401	39.7	516	14.6
	100% of rated load	1,797	50.9	642	18.2
RG15090	25% of rated load	668	18.9	280	7.9
	50% of rated load	1,127	31.9	430	12.2
	75% of rated load	1,583	44.8	573	16.2
	100% of rated load	2,042	57.8	720	20.4

Note: **Fuel pipe must be sized for full load.**

For Btu content, multiply ft<sup>3</sup> / hr x 2,520 (LP) or ft<sup>3</sup> / hr x 1,000 (NG).

For megajoule content, multiply m<sup>3</sup> / hr x 93.15 (LP) or m<sup>3</sup> / hr x 37.26 (NG).

Refer to "Emissions Data Sheets" for maximum fuel flow for EPA and SCAQMD permitting purposes.

STANDBY RATING: Standby ratings apply to installations served by a reliable utility source. The standby rating is applicable to varying loads for the duration of a power outage. There is no overload capability for this rating. Ratings are in accordance with ISO-3046-1. Design and specifications are subject to change without notice.

### 100 / 130 / 150 kW

#### ENGINE COOLING

	100 kW	130 kW	150 kW
Air Flow (Fan Air Flow Across Radiator) - Open Set scfm (m <sup>3</sup> / min)	6,589 (186)	5,415 (153.3)	5,598 (158.5)
System Coolant Capacity (gal / liters)	5.5 (20.8)	6.3 (24.0)	6.3 (24.0)
Heat Rejection to Coolant (BTU per hr / MJ per hr)	Contact Factory	Contact Factory	Contact Factory
Maximum Operation Air Temperature on Radiator (°F / °C)	Contact Factory	Contact Factory	Contact Factory
Maximum Ambient Temperature (°F / °C)	122 (50)	122 (50)	122 (50)

#### COMBUSTION REQUIREMENTS

Flow at Rated Power scfm (m <sup>3</sup> /min)	230 (6.5)	371 (10.5)	343 (9.7)
--	-----------	------------	-----------

#### SOUND EMISSIONS

Sound Output in dB(A) at 23 ft (7 m) With Generator*	71 db	75 db	80 db
--	-------	-------	-------

\*In normal operation

#### EXHAUST

Exhaust Flow at Rated Output scfm (m <sup>3</sup> /min)	771 (21.8)	1,198 (34.0)	1,206 (34.1)
Exhaust Temperature (Rated Output) °F (°C)	1,350 (732)	1,285 (696)	1,440 (782)

#### ENGINE PARAMETERS

Rated Engine Speed (RPM)	1,800	1,800	1,800
--------------------------	-------	-------	-------

#### POWER ADJUSTMENT FOR AMBIENT CONDITIONS

Temperature Deration RG100 / RG130 on NG & LP	77°F before derate	3.3% per 10°F above 77°F
Temperature Deration RG150 on NG	77°F before derate	8% per 5°F above 77°F
Temperature Deration RG150 on LP	77°F before derate	11% per 5°F above 77°F
Altitude Deration (100 kW / 130kW)	3% for every 1,000 ft above 600 ft	
Altitude Deration (150 kW)	2.1% for every 1,000 ft above 600 ft	

#### CONTROLLER FEATURES

Two-Line Plain Text LCD Display .....	Simple user interface for ease of operation.
Mode Switch: AUTO .....	Automatic Start on Utility failure. 7 day exerciser.
OFF .....	Stops unit. Power is removed. Control and charger still operate.
MANUAL .....	Start with starter control, unit stays on. If utility fails, transfer to load takes place.
Programmable Start Delay Between 10-30 Seconds .....	10 sec standard
Engine Start Sequence .....	Cyclic cranking: 16 sec on, 7 rest (90 sec maximum duration)
Engine Warm-up .....	5 sec
Engine Cool-Down .....	1 min
Starter Lock-Out .....	Starter cannot re-engage until 5 sec after engine has stopped.
Smart Battery Charger .....	Standard
Automatic Voltage Regulation With Over and Under Voltage Protection .....	Standard
Automatic Low Oil Pressure Shutdown .....	Standard
Overspeed Shutdown .....	Standard, 72 Hz
High Temperature Shutdown .....	Standard
Overcrank Protection .....	Standard
Safety Fused .....	Standard
Failure to Transfer Protection .....	Standard
Low Battery Protection .....	Standard
50 Event Run Log .....	Standard
Future Set Capable Exerciser .....	Standard
Incorrect Wiring Protection .....	Standard
Internal Fault Protection .....	Standard
Common External Fault Capability .....	Standard
Governor Failure Protection .....	Standard

Model #	Product	Description
G007169-0	Mobile Link® 4G LTE Cellular Accessory	Generac's Mobile Link allows you to check the status of your generator from anywhere that you have access to an Internet connection from a PC or with any smart device. You will even be notified when a change in the generator's status occurs via e-mail or text message. Note: Harness Adapter Kit required. Available in the U.S. only.
G009883-0	Cold Weather Kit	If the temperature regularly falls below 32 °F (0 °C), install a cold weather kit to maintain optimal battery temperature. Kit consists of battery warmer with thermostat built into the wrap.
G009884-0	Extreme Cold Weather Kit	Recommended where the temperature regularly falls below 32 °F (0 °C) for extended periods of time. For liquid cooled units only.
G005651-0	Base Plug Kit	Add base plugs to the base of the generator to keep out debris.
G005703-0 - Bisque	Paint Kit	If the generator enclosure is scratched or damaged, it is important to touch-up the paint to protect from future corrosion. The paint kit includes the necessary paint to properly maintain or touch-up a generator enclosure.
G009882-0	Scheduled Maintenance Kit	The Liquid-Cooled Scheduled Maintenance Kits offer all the hardware necessary to perform complete maintenance on Generac liquid-cooled generators.
G006510-0	E-Stop	E-stop allows for immediate fuel shutoff and generator shutdown in the event of an emergency.
G007005-0	Wi-Fi LP Fuel Level Monitor	The Wi-Fi enabled LP fuel level monitor provides constant monitoring of the connected LP fuel tank. Monitoring the LP tank's fuel level is an important step in making sure your generator is ready to run during an unexpected power failure. Status alerts are available through a free application to notify when your LP tank is in need of a refill.
G007000-0 (50 amp) G007006-0(100 amp)	Smart Management Module	Smart Management Modules (SMM) are used to optimize the performance of a standby generator. They manage large electrical loads upon startup and shed them to aid in recovery when overloaded. In many cases, using SMM's can reduce the overall size and cost of the system.
A0000018981	Ultrasonic Cleaner Solution	An ultra-concentrated anti-corrosive cleaning solution engineered to reach the smallest cavities to clean the toughest contaminants. This water based formula is non-toxic, biodegradable, safe for both metal and plastic surfaces, and is superior in rinsability.
A0000019001	All Surface Protectant	All surface protectant for vinyl, rubber, plastics creates a barrier that seals & protects surfaces from water, UV rays while renewing the look of the surface.

- NOTES:
1. MINIMUM RECOMMENDED CONCRETE PAD SIZE: 6" LARGER PER SIDE THAN FRAME 1269 (50") WIDE 2667 (105") LONG. REFERENCE INSTALLATION GUIDE SUPPLIED WITH UNIT FOR CONCRETE PAD GUIDELINES.
  2. ALLOW SUFFICIENT ROOM ON ALL SIDES OF THE GENERATOR FOR MAINTENANCE AND SERVICING. THIS UNIT MUST BE INSTALLED IN ACCORDANCE WITH CURRENT APPLICABLE NFPA 37 AND NFPA 70 STANDARDS AS WELL AS ANY OTHER FEDERAL, STATE, AND LOCAL CODES.
  3. CONTROL PANEL / CIRCUIT BREAKER INFORMATION:
    - SEE SPECIFICATION SHEET OR OWNERS MANUAL
    - ACCESSIBLE THROUGH CUSTOMER ACCESS ASSEMBLY ON REAR OF GENERATOR
  4. INSIDE STUBUP AREA FOR AC LOAD LEAD CONDUIT CONNECTION, NEUTRAL CONNECTION, BATTERY CHARGER 20 VOLT AC (5 AMP MAX) CONNECTION AND ACCESS TO TRANSFER SWITCH CONTROL WIRES. REMOVE REAR COVER FOR ACCESS.
  5. CENTER OF GRAVITY AND WEIGHT MAY CHANGE DUE TO UNIT OPTIONS.
  6. BOTTOM OF GENERATOR SET MUST BE ENCLOSED TO PREVENT PEST INTRUSION AND RECIRCULATION OF DISCHARGE AIR AND/OR IMPROPER COOLING AIR FLOW.
  7. REFERENCE OWNERS MANUAL FOR LIFTING WARNINGS.
  8. MOUNTING BOLTS OR STUDS TO MOUNTING SURFACE SHALL BE 5/8-11 GRADE 5 USE STANDARD 3/4" TORQUE SPECS!
  9. MUST ALLOW FREE FLOW UP INTAKE AIR, DISCHARGE AIR AND EXHAUST. SEE SPEC SHEET FOR MINIMUM AIR FLOW AND MAXIMUM RESTRICTION REQUIREMENTS.
  10. GENERATOR MUST BE INSTALLED SUCH THAT FRESH COOLING AIR IS AVAILABLE AND THAT DISCHARGE AIR FROM RADIATOR IS NOT RECIRCULATED.
  11. REMOVE FRONT END PANEL TO ACCESS EXHAUST MUFFLER ACCESS AVAILABLE THROUGH DOORS TO FAN BELT.

SERVICE ITEM	9.0L
OIL FILL CAP	EITHER SIDE
OIL DIP STICK	RIGHT SIDE
OIL FILTER	LEFT SIDE
OIL DRAIN HOSE	LEFT SIDE
RADIATOR DRAIN HOSE	LEFT SIDE
COOLANT RECOVERY BOTTLE	RIGHT SIDE
RADIATOR FILL CAP	ROOF TOP
AIR CLEANER ELEMENT	EITHER SIDE
SPARK PLUGS	EITHER SIDE
MUFFLER	SEE NOTE 11
FAN BELT	EITHER SIDE
BATTERY	RIGHT SIDE

REFERENCE OWNERS MANUAL FOR PERIODIC REPLACEMENT PART LISTINGS.

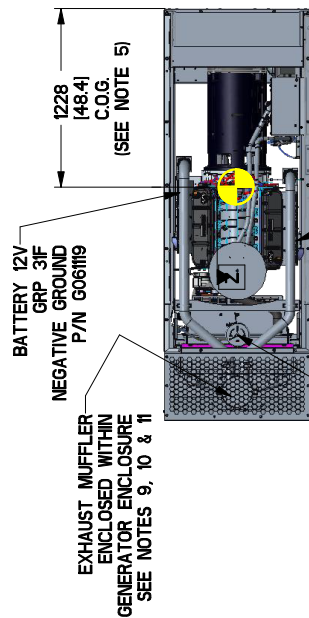

CUSTOMER ACCESS ASSEMBLY, CONTROL PANEL, ACCESS BATTERY CHARGER LOCATED WITHIN SEE NOTE 3 & 4

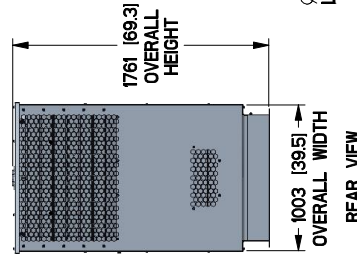
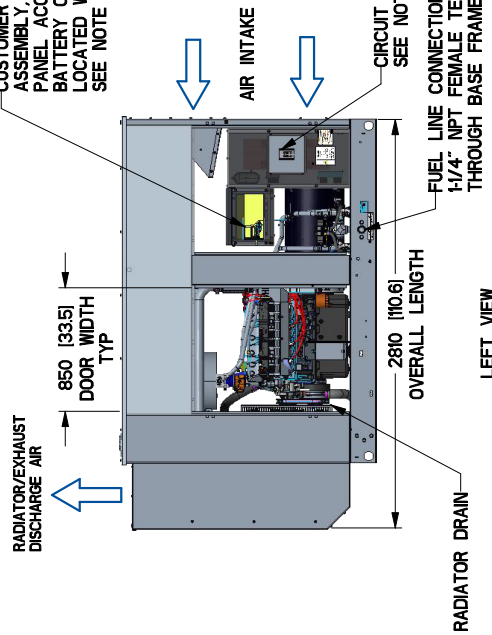

LOCKING VICE ACTION LATCH, ONE PER DOOR TWO LIFT OFF DOORS PER SIDE OF GENERATOR

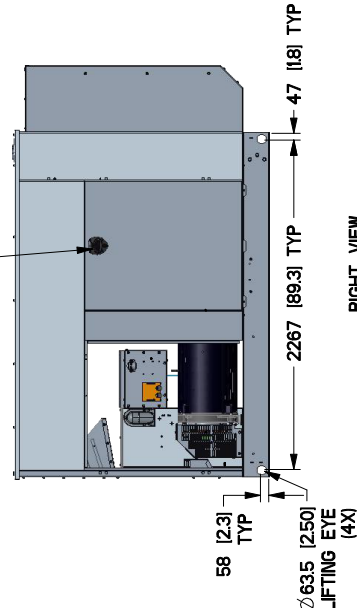

WEIGHT DATA			
ENGINE/KW	ENCLOSURE MATERIAL	WEIGHT GENSET ONLY KG (LBS)	WEIGHT SHIPPING SKID KG (LBS)
9.0L/100KW	AL	1292 [2848]	1371 [3024]

DIMENSIONS: MM (INCH)

# 100 kW

Drawing #A0001453011 (2 of 2)

NOTE:  
STUB-UP AREA FOR HIGH AND LOW  
VOLTAGE CONNECTIONS, CIRCUIT BREAKER,  
NEUTRAL AND CUSTOMER CONNECTION OPENING.

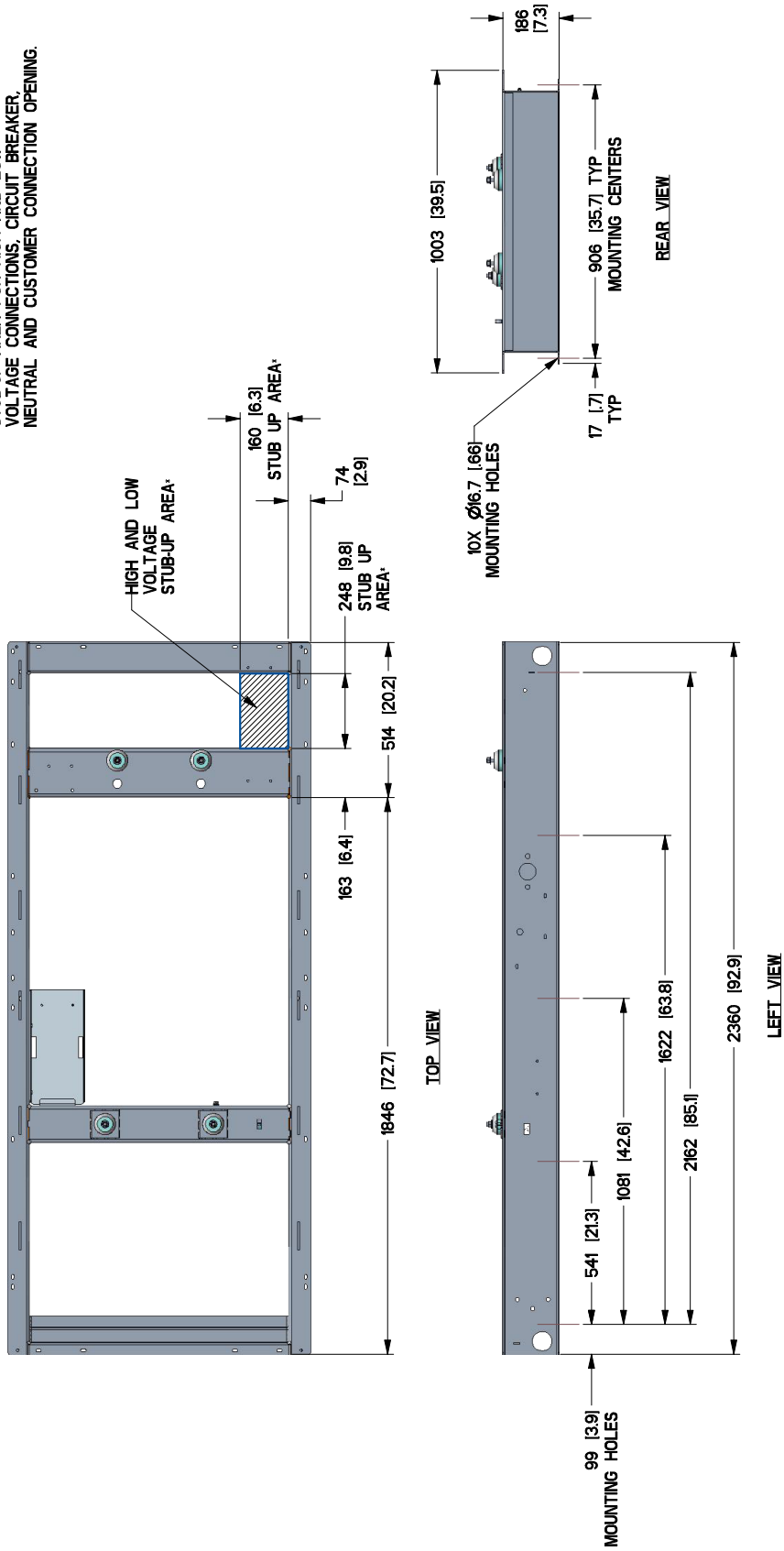

- NOTES:
- MINIMUM RECOMMENDED CONCRETE PAD SIZE: 16" LARGER PER SIDE THAN FRAME
  - 1305 (52) WIDE X 300 (122) LONG
  - REFERENCE INSTALLATION GUIDE SUPPLIED WITH UNIT FOR CONCRETE PAD GUIDELINES.
  - ALLOW SUFFICIENT ROOM ON ALL SIDES OF THE GENERATOR FOR MAINTENANCE ACCESS.
  - APPLICABLE NFPA 70 AND NFPA 70 STANDARDS AS WELL AS ANY OTHER FEDERAL, STATE, AND LOCAL CODES.
  - CONTROL PANEL, 7 CIRCUIT BREAKER INFORMATION
  - SEE SPECIFICATION SHEET OR OWNERS MANUAL
  - ACCESSIBLE THROUGH CUSTOMER ACCESS ASSEMBLY ON LEFT SIDE OF GENERATOR
  - INVERTER/CHARGER BATTERY CHARGER CONNECTION POINTS TO BE INSTALLED ON BATTERY CHARGER 120 VOLT AC (15 AMP MAX) CONNECTION AND ACCESS TO TRANSFER SWITCH CONTROL WIRES REMOVE REAR COVER DUE TO UNIT OPTIONS.
  - CENTER OF GRAVITY AND WEIGHT MAY CHANGE DUE TO UNIT OPTIONS.
  - BOTTOM OF GENERATOR MUST BE ENCLOSED TO PREVENT PEST INTRUSION AND DISCHARGE AIR FROM RADIATOR IS NOT RECIRCULATED.
  - REFERENCE OWNERS MANUAL FOR LIFTING WARNINGS
  - COOLANT RECOVERY BOTTLE COOLING AIR FLOW.
  - MOUNTING BOLTS OR STUDS TO MOUNTING SURFACE SHALL BE 5/8-11 GRADE 5 (USE STANDARD SAE TORQUE SPECS)
  - MUST ALLOW FREE FLOW OF INTAKE AIR, DISCHARGE AIR AND EXHAUST. SEE SPEC FOR MINIMUM CLEARANCE REQUIREMENTS.
  - GENERATOR MUST BE INSTALLED SUCH THAT FRESH COOLING AIR IS AVAILABLE AND THAT DISCHARGE AIR FROM RADIATOR IS NOT RECIRCULATED.
  - REMOVE FRONT END PANEL TO ACCESS EXHAUST IMPELLER ACCESS AVAILABLE THROUGH DOORS TO FAN BELT.

SERVICE ITEM	9.0L
OIL FILL CAP	EITHER SIDE
OIL DIP STICK	RIGHT SIDE
OIL FILTER	LEFT SIDE
OIL DRAIN HOSE	RIGHT SIDE
RADIATOR DRAIN HOSE	LEFT SIDE
COOLANT RECOVERY BOTTLE	RIGHT SIDE
RADIATOR FILL CAP	ROOF TOP
AIR CLEANER ELEMENT	EITHER SIDE
SPARK PLUGS	EITHER SIDE
MAFFLER	SEE NOTE 11
FAN BELT	EITHER SIDE
BATTERY	RIGHT SIDE

REFERENCE OWNERS MANUAL FOR PERIODIC REPLACEMENT PART LISTINGS.

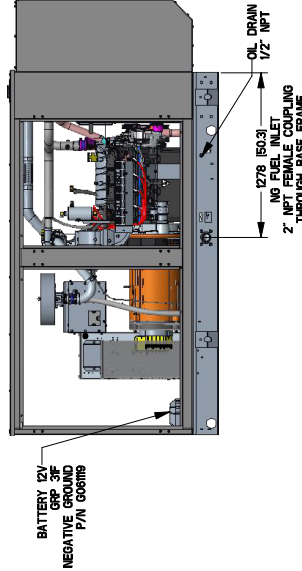
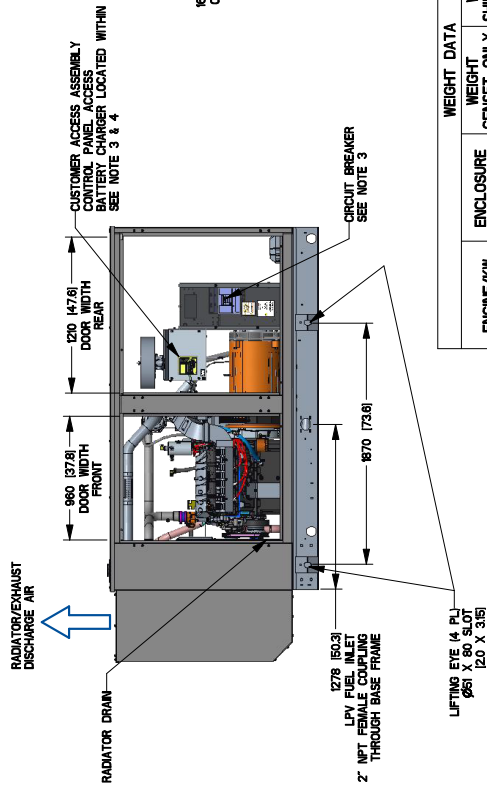
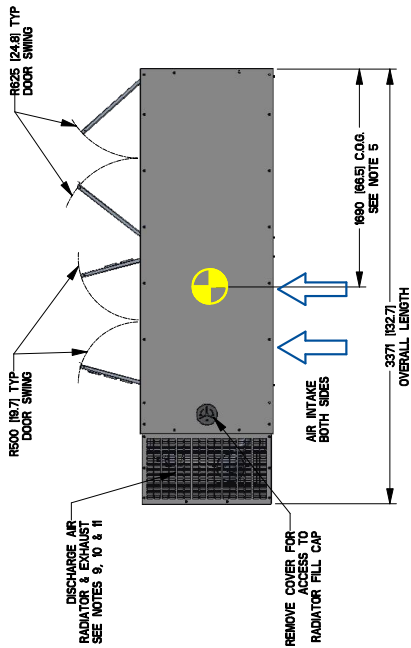

DIMENSIONS: MM (INCH)

ENGINE/KW	WEIGHT DATA		
	WEIGHT GENSET ONLY KG (LBS)	WEIGHT SHIPPING SKID KG (LBS)	WEIGHT SHIPPING WEIGHT KG (LBS)
9.0L/130KW	1385 (3009)	80 (176)	1445 (3185)



# 130 kW

Drawing #A0001618959 (2 of 2)

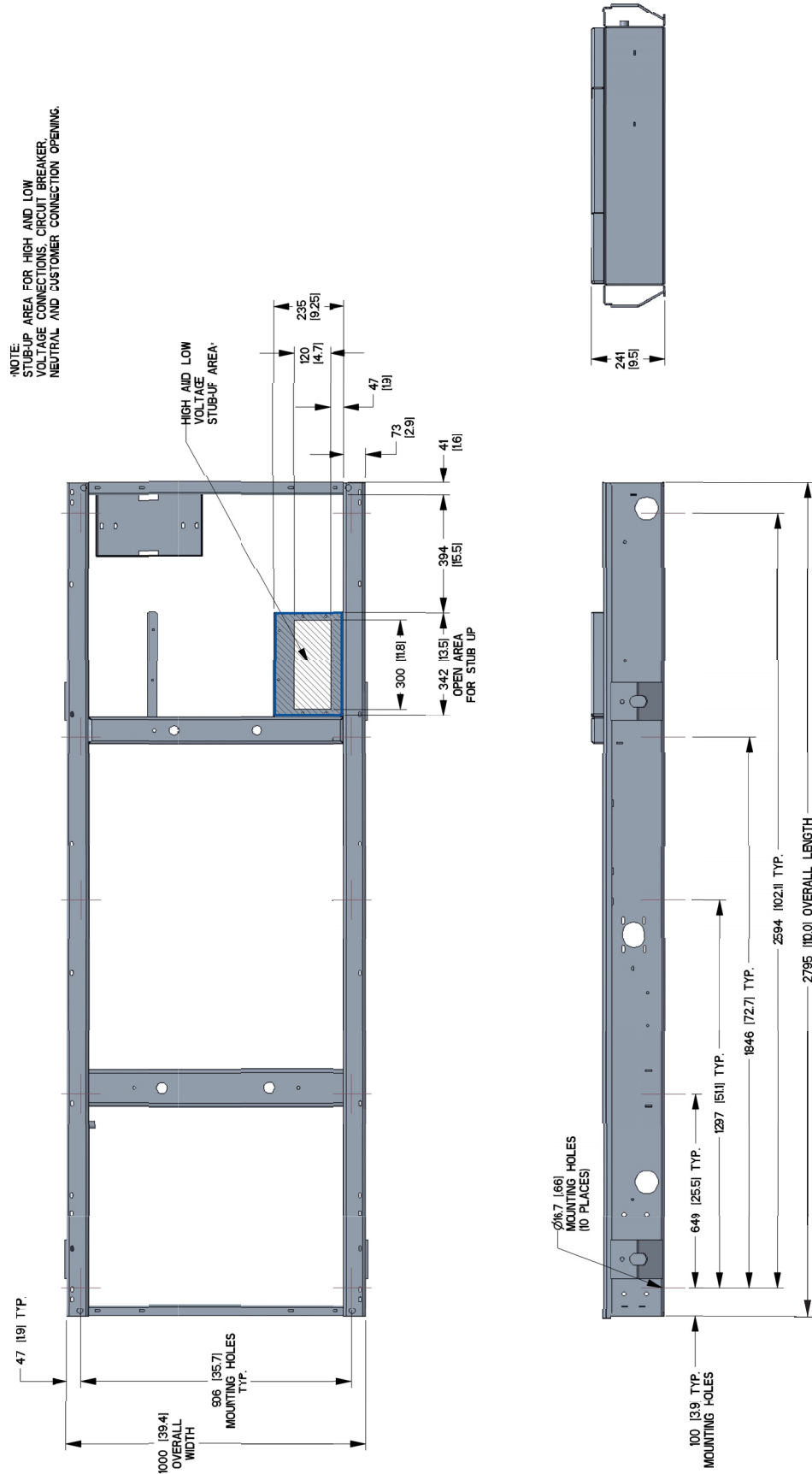

150 kW

Drawing #A0001618957 (1 of 2)

installation layout

NOTES:

- MINIMUM RECOMMENDED CONCRETE PAD SIZE: 16" LARGER PER SIDE THAN FRAME
- 1654 (62.7) IN. 2055 (102.9) IN. LONG SUPPLIED WITH UNIT FOR CONCRETE PAD GUIDELINES.
- INDOOR INSTALLATION ONLY. UNIT MUST BE INSTALLED IN A WELL VENTILATED AREA.
- ALLOW SUFFICIENT ROOM ON ALL SIDES OF THE GENERATOR FOR MAINTENANCE AND SERVICING. THIS UNIT MUST BE INSTALLED IN ACCORDANCE WITH CURRENT APPLICABLE NFPA 37 AND NFPA 70 STANDARDS AS WELL AS ANY OTHER FEDERAL, STATE, AND LOCAL CODES.
- SEE SPECIFICATION SHEET FOR BREAKER INFORMATION.
- SEE SPECIFICATION SHEET FOR OWNERS MANUAL.
- ACCESSIBLE THROUGH CUSTOMER ACCESS ASSEMBLY ON LEFT SIDE OF GENERATOR.
- INSIDE STUBUP AREA FOR AC LOAD LEAD CONDUIT CONNECTION, NEUTRAL CONNECTION, BATTERY CHARGER 120 VOLT AC (5 AMP MAX) CONNECTION AND ACCESS TO TRANSFER SWITCH.
- CENTER OF GRAVITY AND WEIGHT MAY CHANGE DUE TO UNIT OPTIONS.
- BOTTOM OF GENERATOR SET MUST BE ENCLOSED TO PREVENT PEST INTRUSION AND RECIRCULATION OF DISCHARGE AIR AND/OR IMPROPER COOLING AIR FLOW.
- REFERENCE OWNERS MANUAL FOR LIFTING WARNINGS.
- INSIDE STUBUP AREA FOR TROUBLE SHOOTING.
- USE 5/8" DIA. 5" LONG THROUGH HOLES.
- MUST ALLOW FREE FLOW OF INTAKE AIR, DISCHARGE AIR AND EXHAUST. SEE SPEC SHEET FOR MINIMUM AIR FLOW AND MAXIMUM RESTRICTION REQUIREMENTS.
- GENERATOR MUST BE INSTALLED SUCH THAT FRESH COOLING AIR IS AVAILABLE AND THAT DISCHARGE AIR FROM GENERATOR IS NOT RECIRCULATED.
- SEE SPECIFICATION SHEET FOR ACCESS EXHAUST IMPLIFIER, ACCESS AVAILABLE THROUGH DOORS TO FAN BELT.

SERVICE ITEM	9.0L
OIL FILL CAP	EITHER SIDE
OIL DIP STICK	RIGHT SIDE
OIL FILTER	LEFT SIDE
OIL DRAIN HOSE	RIGHT SIDE
RADIATOR DRAIN HOSE	LEFT SIDE
COOLANT RECOVERY BOTTLE	RIGHT SIDE
RADIATOR FILL CAP	ROOF TOP
AIR CLEANER ELEMENT	EITHER SIDE
SPARK PLUGS	EITHER SIDE
MUFFLER	SEE NOTE 11
FAN BELT	EITHER SIDE
BATTERY	RIGHT SIDE

REFERENCE OWNERS MANUAL FOR PERIODIC REPLACEMENT PART LISTINGS.

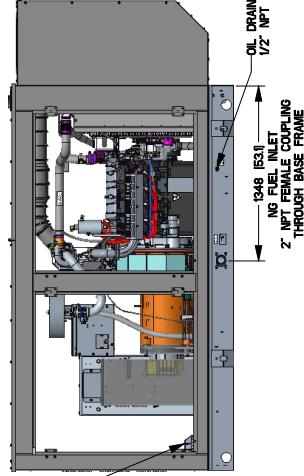
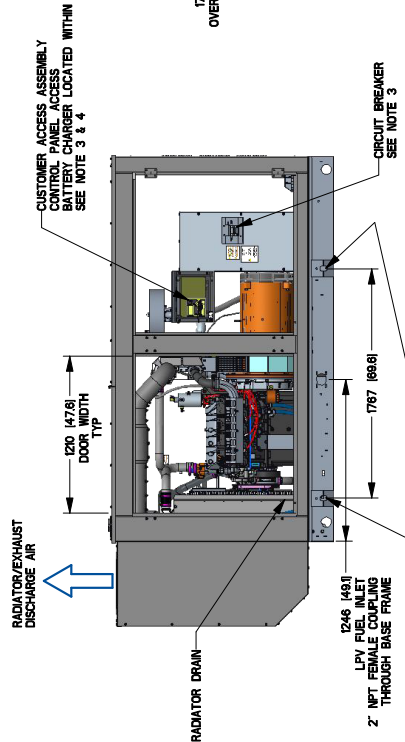
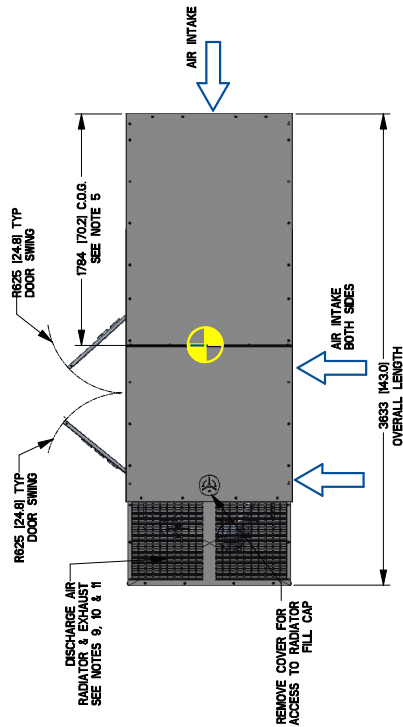

ENGINE/KW	WEIGHT DATA	
	WEIGHT GENSET ONLY	WEIGHT SHIPPING SKID
9.0L/150KW	1487 [327.8] KG [LB]	1618 [356.0] KG [LB]

DIMENSIONS: MM (INCH)

**150 kW**

Drawing #A0001618957 (2 of 2)

