

WP1X - Steel AISI 316L Boiler for heat pumps

WP2X - Steel AISI 316L Boiler for heat and solar pumps



Stainless steel AISI 316L boiler for the production and storage of domestic hot water provided by one or two Internal fixed coil heat exchangers with high heat exchange surface; it can be powered by the heat pump and solar plant.

Rigid factory insulation is supplied as standard. Please enquire should you require removable flexible insulation.



TECHNICAL CHARACTERISTICS

Sanitary	Material:	Inox AISI 316L (1.4404)
	Internal protective processing:	Pickling and passivation
	External protective processing:	Pickling and passivation
	Operation (P max. / T max.):	6 bar / 95°C
	Cathodic protection:	Magnesium anode
Upper exchanger (heat pump)	Material:	Inox AISI 316L (1.4404)
	Internal protective processing:	Pickling and passivation
	External protective processing:	Pickling and passivation
Lower exchanger (solar)	Typology:	Fixed coil with a double parallel spiral
	Operation (P max. / T max.):	12 bar / 95°C
	Capacity:	300 - 2000 Lt
General characteristics	Warranty:	5 years
	Insulation:	- Rigid polyurethane + pvc: <i>Fire resistance class B3 (DIN 4102)</i>
		- Flexible Polyester + pvc: <i>Fire resistance class B2 (DIN4102)</i>
	Reference legislation:	- PED 14/68/UE Art. 4 Par. 3 (Pressure equipment)
		- M.D. of 6th April 2004 N.174 (suitability of materials in contact with SHW) - Directive 2009/125/CE (Energy related Products)

FITTINGS
(pag. 152)



Electronic anode with impressed current



Electronic control unit



Electrical resistance 1 1/2 connection



Thermostat



Thermometer

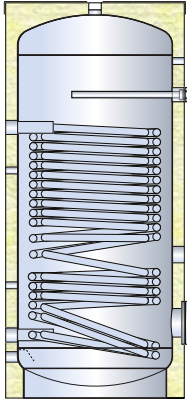

WP1X - Steel AISI 316L Boiler for heat pumps						
Flexible polyester insul. 100 mm thick + pvc			Rigid Polyurethane insulation + pvc			
Code	ErP	€	Code	Thickness (mm)	ErP	€
-	-	-	WP1X 00300 R	50	B	-
-	-	-	WP1X 00400 R	50	B	-
-	-	-	WP1X 00500 R	50	B	-
-	-	-	WP1X 00600 R	50	C	-
WP1X 00800 F	D	-	WP1X 00800 R	100	C	-
WP1X 01000 F	D	-	WP1X 01000 R	100	C	-
WP1X 01500 F	D	-	WP1X 01500 R	100	C	-
WP1X 02000 F	D	-	WP1X 02000 R	100	C	-

For bigger capacities require estimate

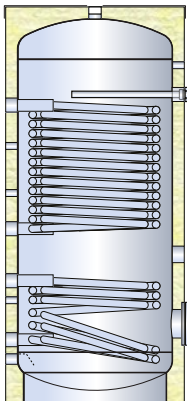

WP2X - Steel AISI 316L Boiler for heat and solar pumps						
Flexible polyester insul. 100 mm thick + pvc			Rigid Polyurethane insulation + pvc			
Code	ErP	€	Code	Thickness (mm)	ErP	€
-	-	-	WP2X 00300 R	50	B	-
-	-	-	WP2X 00400 R	50	B	-
-	-	-	WP2X 00500 R	50	B	-
-	-	-	WP2X 00600 R	50	C	-
WP2X 00800 F	D	-	WP2X 00800 R	100	C	-
WP2X 01000 F	D	-	WP2X 01000 R	100	C	-
WP2X 01500 F	D	-	WP2X 01500 R	100	C	-
WP2X 02000 F	D	-	WP2X 02000 R	70	C	-

For bigger capacities require estimate

Caution: Indicative Schematic diagram, not substitutive for project work.

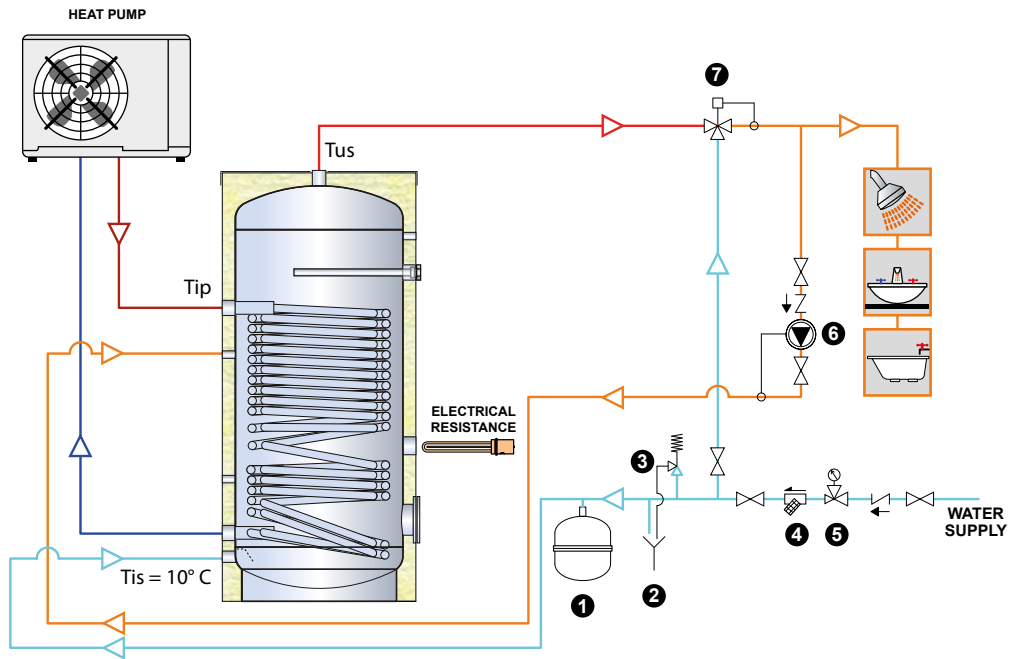

LEGEND

- 1. Expansion vessel
- 2. Sanitary drain
- 3. Sanitary safety valve (6 bar)
- 4. Dirt filter
- 5. Pressure reducer
- 6. Sanitary circulation pump
- 7. Sanitary mixing valve

Model	exchanger						Amount of water in the first 10 min (Lt/10')
	Sq.m. (Lt)	Lt/h (mca)	Tip (°C)	production of Sanitary Hot Water		NL*	
				Tus=45°C			
				Power (kW)	Flow (Lt/h)		
WP1X 00300R	3,5 (24,9)	2000 (0,2)	65	56,2	1380	2,3	568
			55	39,3	966		520
WP1X 00400R	4,5 (32,0)	3000 (0,4)	65	75,2	1848	3,5	728
			55	52,4	1287		672
WP1X 00500R	5,7 (40,5)	3000 (0,5)	65	88,9	2185	5,8	893
			55	62,4	1533		829
WP1X 00600R	5,7 (40,5)	3000 (0,6)	65	88,9	2185	6,1	1018
			55	62,4	1533		957
WP1X 00800_	6 (42,6)	3000 (0,7)	65	92,3	2267	6,6	1282
			55	64,8	1593		1224
WP1X 01000_	6 (42,6)	3000 (0,7)	65	92,3	2267	7,8	1535
			55	64,8	1593		1482
WP1X 01500_	7,5 (53,3)	4000 (1,2)	65	117,0	2876	11,0	2223
			55	82,1	2017		2167
WP1X 02000_	10,4 (73,8)	4000 (1,7)	65	145,3	3570	18,3	2893
			55	103,3	2538		2841

* Efficiency coefficient NL (DIN 4708)

For the purposes of the Directive (ErP) 2009/125/EC Regulation N° 812/2013 and N° 814/2013 the results of the energy measurements are given on page 218

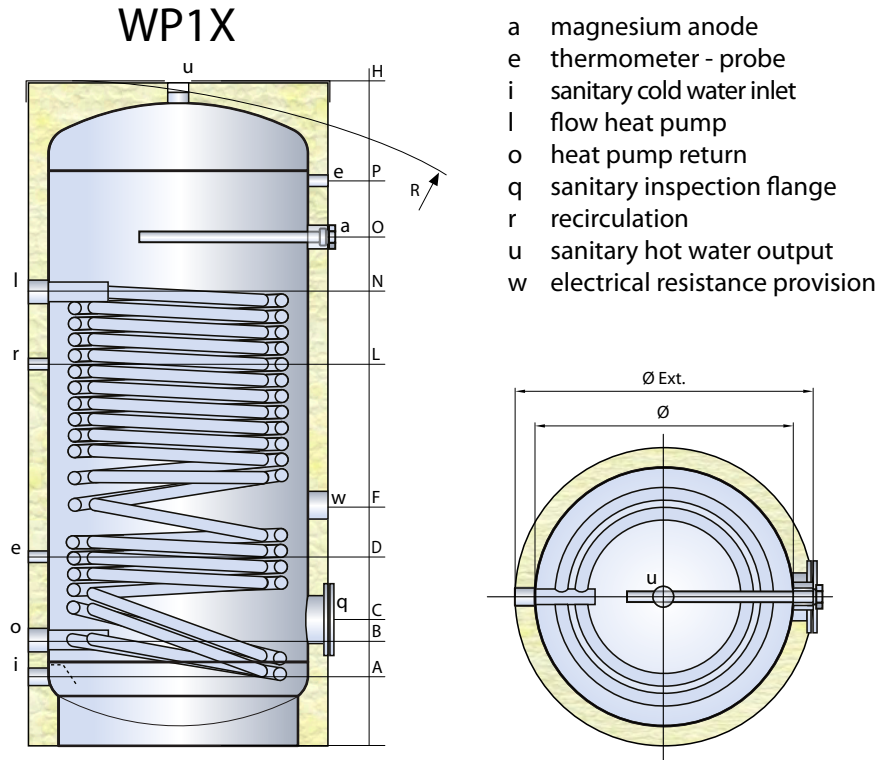

- a magnesium anode
- e thermometer - probe
- i sanitary cold water inlet
- l flow heat pump
- o heat pump return
- q sanitary inspection flange
- r recirculation
- u sanitary hot water output
- w electrical resistance provision

Model	Dimensions (mm)				Exchanger (Sq.m.)	Weight (Kg)
	Ø	H	Ø Ext **	R *		
WP1X 00300R	500	1595	600	1720	3,50	91
WP1X 00400R	650	1395	750	1600	4,50	110
WP1X 00500R	650	1645	750	1820	5,70	131
WP1X 00600R	650	1895	750	2050	5,70	142
WP1X 00800_	790	1750	990	1745	6,00	168
WP1X 01000_	790	2110	990	2095	6,00	188
WP1X 01500_	1000	2115	1200	2145	7,50	271
WP1X 02000_	1100	2435	1300	2465	10,40	362

* For capacities from 300 to 600 Lt the diagonal of rollover is referred to the insulated tank

** All insulations are removable except for models from 300 to 600 LT

Model	Dimensions (mm)									Connections (gas)							
	A	B	C	D	F	L	N	O	P	a	o	e	r	i	u	w	q
WP1X 00300R	120	210	300	320	495	925	1110	1160	1365	1"1/4	1/2"	1/2"	1"	1"1/2	120/180		
WP1X 00400R	145	240	310	340	525	870	1005	1030	1140	1"1/4	1/2"	1/2"	1"	1"1/2	120/180		
WP1X 00500R	145	240	310	350	570	1020	1250	1280	1390	1"1/4	1/2"	1/2"	1"	1"1/2	120/180		
WP1X 00600R	145	240	310	390	605	1070	1250	1510	1640	1"1/4	1/2"	1/2"	1"	1"1/2	120/180		
WP1X 00800_	170	275	345	405	620	1000	1170	1310	1425	1"1/4	1/2"	1"	1"1/2	1"1/2	120/180		
WP1X 01000_	170	275	345	475	750	1120	1275	1615	1770	1"1/4	1/2"	1"	1"1/2	1"1/2	120/180		
WP1X 01500_	230	345	475	535	805	1165	1325	1600	1740	1"1/4	1/2"	1"	2"	1"1/2	220/290		
WP1X 02000_	325	455	585	655	1030	1385	1530	1885	2035	1"1/4	1/2"	1"	2"	1"1/2	220/290		

Caution: Indicative Schematic diagram, not substitutive for project work.

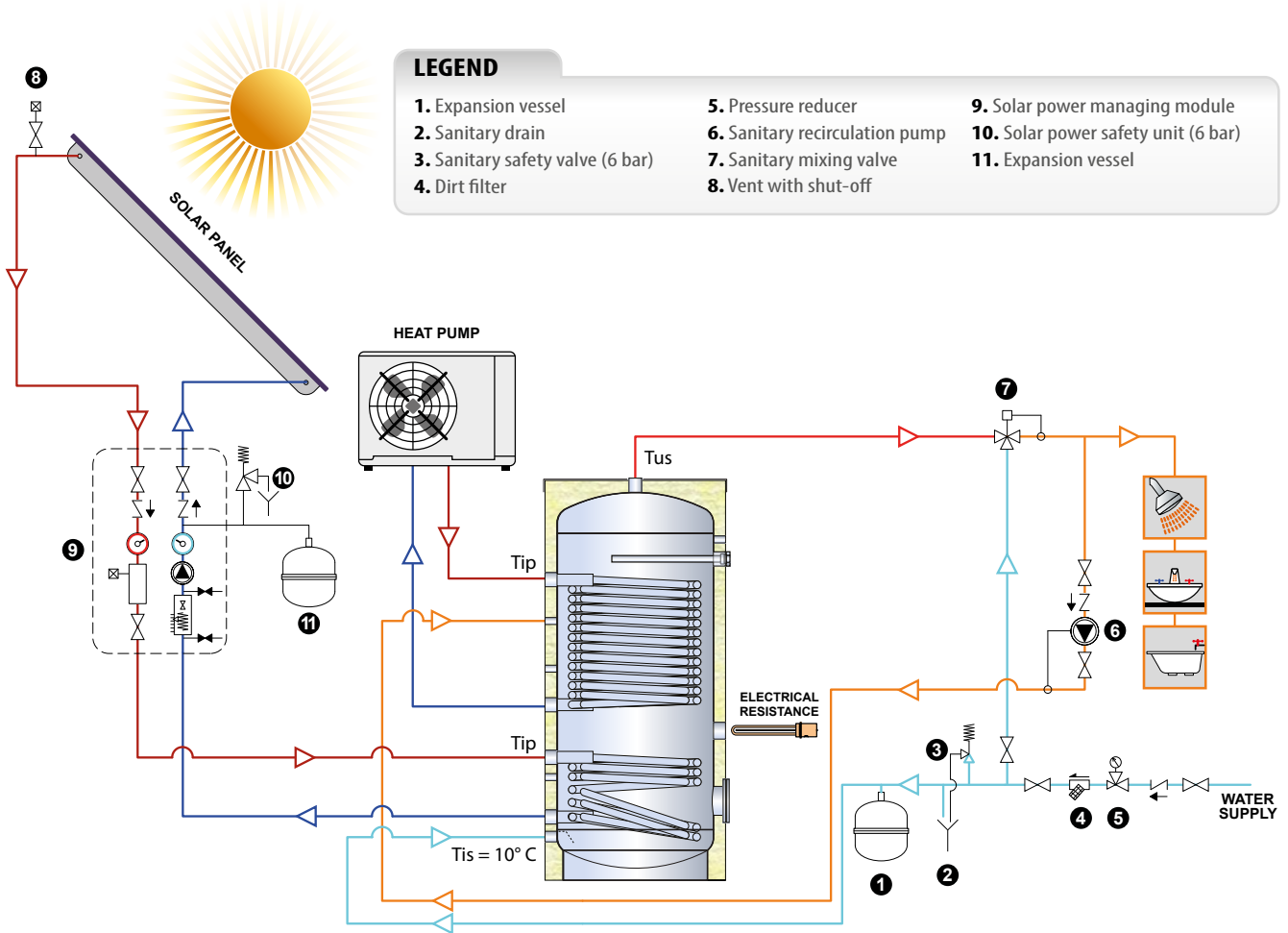

Model	lower exchanger					upper exchanger					Amount of water in the first 10 min (Lt/10')	
	Sq.m. (Lt)	Lt/h (mca)	Tip (°C)	production of Sanitary Hot Water Tus=45°C		Sq.m. (Lt)	Lt/h (mca)	Tip (°C)	production of Sanitary Hot Water Tus=45°C			NL*
				Power (kW)	Flow (Lt/h)				Power (kW)	Flow (Lt/h)		
WP2X 00300R	1 (7,1)	2000 (0,1)	80	29,1	715	2,4 (17,0)	2000 (0,1)	65	42,2	1036	1,6	528
			70	23,1	567			55	29,2	719		491
WP2X 00400R	1,2 (8,5)	3000 (0,1)	80	35,6	875	3 (21,3)	3000 (0,3)	65	54,6	1341	2,4	677
			70	28,3	694			55	37,8	928		636
WP2X 00500R	1,5 (10,6)	3000 (0,2)	80	43,6	1072	4,2 (29,8)	3000 (0,4)	65	71,1	1747	3,0	850
			70	34,6	851			55	49,5	1216		798
WP2X 00600R	2 (14,2)	3000 (0,3)	80	55,8	1370	5 (35,5)	3000 (0,5)	65	81,4	1999	4,9	1001
			70	44,8	1100			55	56,8	1396		945
WP2X 00800_	2 (14,2)	3000 (0,3)	80	55,8	1370	5,2 (36,9)	3000 (0,6)	65	83,5	2051	5,1	1263
			70	44,8	1100			55	58,4	1435		1210
WP2X 01000_	3,3 (23,4)	3000 (0,5)	80	84,8	2082	6 (42,6)	3000 (0,7)	65	92,3	2267	6,5	1535
			70	67,5	1659			55	64,8	1593		1482
WP2X 01500_	3,6 (25,5)	4000 (0,6)	80	95,9	2356	7,5 (53,2)	4000 (1,2)	65	117,0	2876	9,5	2223
			70	77,2	1897			55	82,1	2017		2167
WP2X 02000_	5,5 (39,0)	4000 (0,7)	80	134,1	3294	8,5 (60,3)	4000 (1,4)	65	128,8	3164	12,5	2872
			70	107,0	2630			55	90,6	2227		2826

* Efficiency coefficient NL (DIN 4708)

For the purposes of the Directive (ErP) 2009/125/EC Regulation N° 812/2013 and N° 814/2013 the results of the energy measurements are given on page 218

WP2X

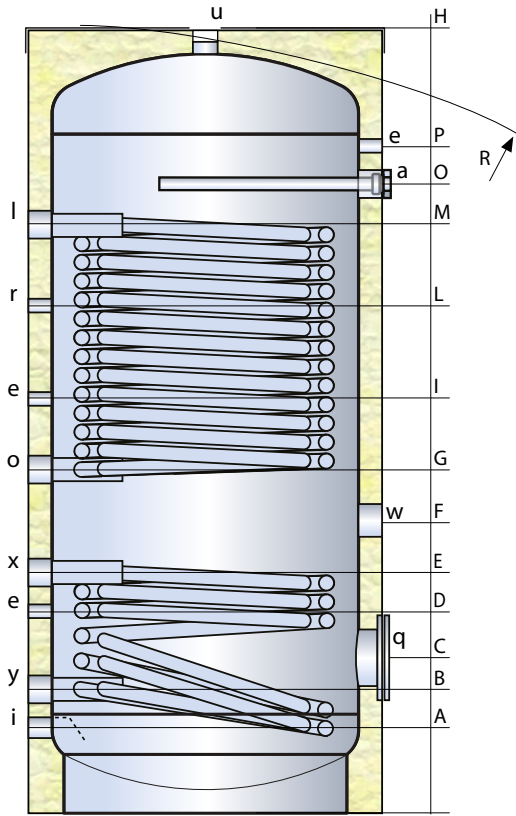

- a magnesium anode
- e thermometer - probe
- i sanitary cold water inlet
- l flow heat pump
- o heat pump return
- q sanitary inspection flange
- r recirculation
- u sanitary hot water output
- w electrical resistance provision
- x solar flow
- y solar return

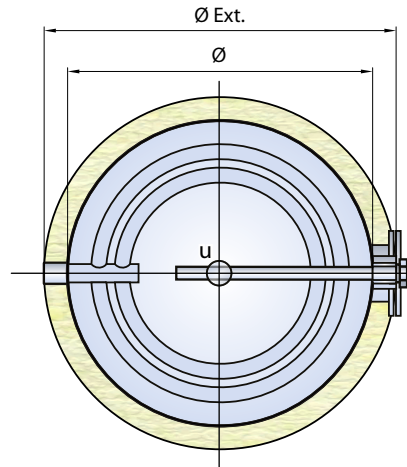

Model	Dimensions (mm)				Exchanger (Sq.m.)		Weight (Kg)
	Ø	H	Ø Ext **	R *	Lower	Upper	
WP2X 00300R	500	1595	600	1720	1,00	2,40	90
WP2X 00400R	650	1395	750	1600	1,20	3,00	107
WP2X 00500R	650	1645	750	1820	1,50	4,20	131
WP2X 00600R	650	1895	750	2050	2,00	5,00	154
WP2X 00800_	790	1750	990	1745	2,00	5,20	179
WP2X 01000_	790	2110	990	2095	3,30	6,00	219
WP2X 01500_	1000	2115	1200	2145	3,60	7,50	305
WP2X 02000_	1100	2435	1300	2465	5,50	8,50	396

* For capacities from 300 to 600 Lt the diagonal of rollover is referred to the insulated tank

** All insulations are removable except for models from 300 to 600 LT

Model	Dimensions (mm)												Connections (gas)						
	A	B	C	D	E	F	G	I	L	M	O	P	ax	yl	o	e	r	iu	w
WP2X 00300R	120	210	300	320	430	495	560	745	925	1110	1160	1365	1"1/4	1/2"	1/2"	1"	1"1/2	120/180	
WP2X 00400R	145	240	310	340	440	525	565	720	870	1005	1030	1140	1"1/4	1/2"	1/2"	1"	1"1/2	120/180	
WP2X 00500R	145	240	310	350	460	570	610	820	1020	1250	1280	1390	1"1/4	1/2"	1/2"	1"	1"1/2	120/180	
WP2X 00600R	145	240	310	390	540	605	670	870	1070	1470	1510	1640	1"1/4	1/2"	1/2"	1"	1"1/2	120/180	
WP2X 00800_	170	275	345	405	535	620	665	835	1000	1270	1310	1425	1"1/4	1/2"	1"	1"1/2	1"1/2	120/180	
WP2X 01000_	170	275	345	475	675	750	825	975	1120	1575	1615	1770	1"1/4	1/2"	1"	1"1/2	1"1/2	120/180	
WP2X 01500_	230	345	475	535	730	805	880	1025	1165	1560	1600	1740	1"1/4	1/2"	1"	2"	1"1/2	220/290	
WP2X 02000_	325	455	585	655	955	1030	1105	1245	1385	1805	1885	2035	1"1/4	1/2"	1"	2"	1"1/2	220/290	