



ST9420C Wireless enabled programmer

DT92E Wireless digital room thermostat

CS92A Wireless cylinder thermostat

Wireless enabled



2 way wireless communication



Sundial RF² Pack 3

Sundial RF² Pack 3 contains a wireless enabled programmer (ST9420C), a wireless thermostat (DT92E), and a wireless cylinder thermostat (CS92A).

For new and existing stored hot water heating systems, using the traditional layout of separate time control and room thermostat.

In a stored hot water heating system which has no room thermostat or cylinder thermostat the existing wiring can be used to provide Boiler Interlock by fitting Sundial RF² Pack 3.

Installation

Simply remove the old programmer and replace with ST9420C. The wireless thermostat (DT92E) and cylinder thermostat (CS92A) are enabled automatically.



ST9420C

Wireless enabled programmer

- Fits on industry standard backplate - no need to re-wire
- Direct replacement for ST9400 and ST6400 models
- Large backlit display - easy to read
- Choice of 3 different built in programmes for energy saving
- Set every day differently with 7 day programming - flexible to suit users lifestyle
- Service mode - set a service reminder with the option of a phone number displayed on screen and/or a service countdown
- Factory set time and date - fast set up
- 2 level battery backup - maintains settings in event of power failure
- Installer mode - allows control to be matched to the system
- Enquiry mode - access temperature information from other system components
- Meets Building Regulations Part L
- Optimisation - Optimum Start, Delayed Start and Optimum Stop energy saving technology
- All the features of the ST9400 models

Specification clauses

- Central heating programmer with large clear high contrast display measuring 57 x 37mm
- Central heating programmer to have built in wireless receiver
- Preset programmes for three typical usage patterns
- Programmer to be adaptable to suit 7 day, 5/2 day and 1 day applications
- Backlighting for display to consume no additional power
- Display to carry text messages to assist installation, set up and use
- All programming actions to be confirmed by a button press with tactile and visual confirmation
- All programme data to be stored permanently in the event of power outage
- Battery backup for lock settings to be two level
- User buttons to extend daily programme periods for up to three hours
- User buttons to allow user to switch off their heating for a variable number of days (1 – 99) when on holiday
- Wireless cylinder thermostat (CS92A)

Options

Sundial RF² Pack 1 - Y9120H

ST9120C and DT92E

Sundial RF² Pack 2 - Y9420H

ST9420C and DT92E

Sundial RF² Pack 3 - Y9420S

ST9420C, DT92E and CS92A

Specification table ST9420C

Switch Rating	: 3(3)A max at 230Vac
Switch Type	: 2x Single pole, double throw (SPDT) relay
Power Supply	: 230VAC 50Hz 10W
RF Communication Range	: Up to 30m in residential buildings, two way short, high rate transmissions to minimise air time and avoid interference
Power Reserve	: All settings and parameters stored in NVRAM will be retained indefinitely
Time Setting Resolution	: Time of day – 1 minute : Programme time changes – 10 minutes
Temperature Setting Range	: 5 to 35°C in 0.5°C steps can be limited between 5 and 35°C
Temperature Control Accuracy	: ± 0.5K at 20°C (50% load, 3k/hr)
Time Display	: 24 hour or 12 hour AM/PM format

Wiring diagram

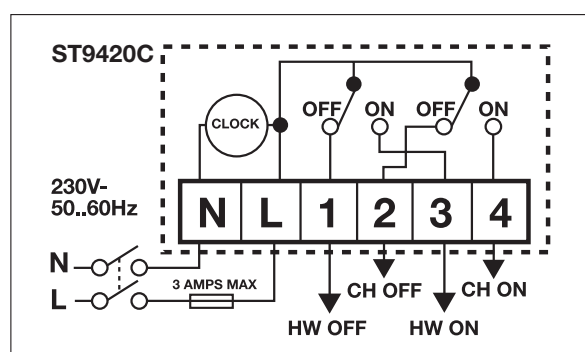

Just replace existing programmer.



DT92E Wireless digital room thermostat

- TPI control - energy saving
- ECO button - gives timed setback or boosts temperatures to reduce energy demand
- 30 metres wireless range - easy to set up
- Two way wireless communication - energy saving
- Heating 'ON' indicator
- Signal strength indicator - easy to set up
- Simple user operation - less call backs
- 5 to 35°C setpoint range - flexible
- Frost protection
- Meets Building Regulations Part L
- Installer mode - allows control to be matched to the system and user requirements
- Wall mounted or free standing - flexible location



CS92A Wireless cylinder thermostat

- Hot water temperature set at programmer
- Pre-bound to programmer and ready to use
- Fits on new or existing systems
- Battery powered

Optimisation

The Sundial RF² Packs have optional features called Optimisation, which aim to save energy while making you as comfortable as possible. Optimisation does not apply to your hot water, only to your heating.

Optimum Start

To save energy, let the controls work out when to come on to suit when you want to be warm. Every day the boiler will start at the latest possible moment depending on the weather.

Delayed Start

Once you have programmed your earliest start time, the controls will delay the boiler firing time on warmer days, when it is possible to save energy.

Optimum Stop

Saves energy and money by switching off before the normal programme time whenever possible.

Schematic layout

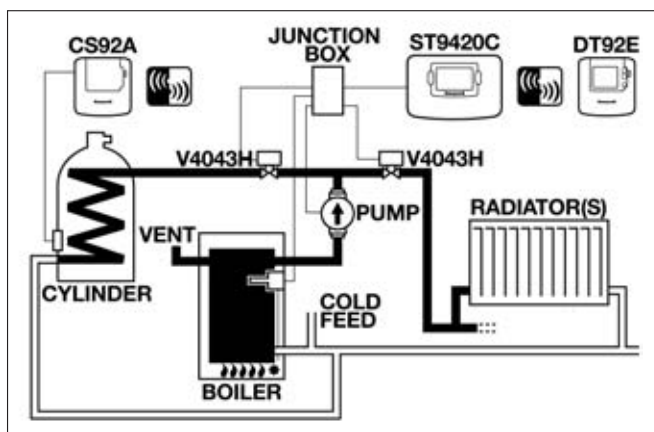

TPI Control

Time Proportional and Integral (TPI) control is a method of calculating the demand from a room thermostat, controlling the boiler so that it fires for shorter periods as the temperature approaches the set point. This can offer savings of up to 10% of energy consumption (in a single cycle steady state test).

On/Off control

Temperature variation with a standard mechanical room thermostat

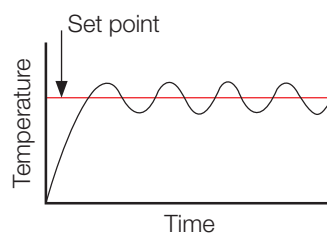

TPI control

Temperature variation with a TPI room thermostat

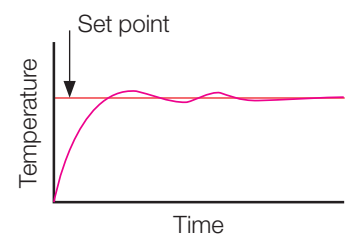

Sundial RF² Pack 3

Sundial RF² Pack 3 offers a wireless solution to new and existing stored hot water heating systems, using the traditional layout of separate time control and room thermostat.

Simply by fitting this new time control, the wireless room thermostat and cylinder thermostat are enabled automatically.

With Sundial RF² Packs there is no need to run new cables, which means no mess, no fuss and no making good. A quick and clean energy saver.

Domestic Energy Consumption

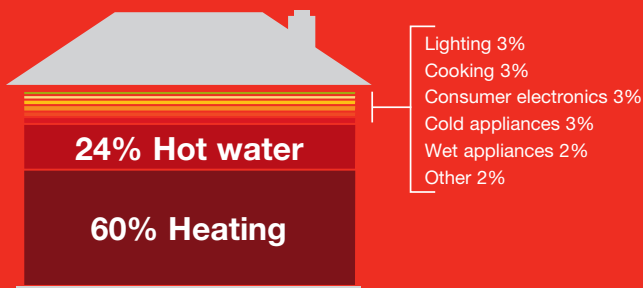

© 2009 Honeywell International Inc.
Source: BERR & Energy Saving Trust

Controlling heating is really important, as 84% of domestic energy consumption is in heating and hot water, which also produce 70% of domestic carbon emissions.

Turning the thermostat down by 1°C will reduce energy consumption by 10%. This will have more effect than turning off all your light bulbs and never using them again. Yet 8½ million homes in the UK have no room thermostat on their heating.

Pack Contents



ST9420C
Wireless enabled programmer

- Fits new or existing systems
- Line of text display with on screen instructions - no need for a user guide
- Large backlit display - easy to read
- Up to 3 on/off periods a day - tailor the programme to suit your lifestyle



DT92E
Wireless digital room thermostat

- TPI control - save energy
- ECO button - save energy
- Large clear display - easy to use
- Heating 'ON' indicator - easy to see when boiler is on



CS92A
Wireless cylinder thermostat

- Hot water temperature set at programmer
- Pre-bound to programmer and ready to use
- Fits on new or existing systems



Honeywell
Honeywell House, Bracknell
Berkshire, RG12 1EB
Tel: 01344 656000
Fax: 01344 656240
E-mail: uk.infocentre@honeywell.com
www.honeywelluk.com

Honeywell

EN3H-2929 UK01 R1209