

Pellet boiler
PRO-Flex

Planning and Installation

PRO-Flex-A-00-00-00-01-IADE



DE-B31-013-V03-1013

GUNTAMATIC

Information on this documentation

Read through this documentation carefully.

It is intended as a reference document and contains important information on the design, safety, operation, maintenance and care of your heating system.

We are always looking to improve our products and documentation. Any ideas and suggestions you may have will be gratefully received.

GUNTAMATIC Heiztechnik GmbH

Bruck 7

A-4722 PEUERBACH

Tel: 0043 (0) 7276 / 2441-0

Fax: 0043 (0) 7276 / 3031

E-mail: office@guntamatic.com



It is important that you pay particular attention to the safety issues highlighted in the text by these symbols.

The entire contents of this document are the property of GUNTAMATIC and therefore protected by copyright. Reproduction of any kind, communication to third parties by any means or use for purposes other than those intended without the written consent of the owner is prohibited.

Subject to printing errors and technical amendments.

Contents

	Page
1 Introduction	4
1.1 Safety instructions	4
1.2 Guarantee	4
1.3 Commissioning	4
1.4 Site requirements	4
2 Planning and Installation	5
2.1 Fire safety (minimum fire safety requirements)	5
2.2 Boiler room requirements	7
2.3 Flue requirements	9
2.4 Fuel store requirements	10
2.5 Planning examples for the fuel store	12
2.6 Delivery	14
2.7 Carrying to installation site	14
2.8 Positioning and aligning the system	14
2.9 Plumbing connections	15
2.10 Filling and bleeding the system	17
2.11 Connecting the flue	18
2.12 Energy saving draught regulator with pressure-surge compensator	19
2.13 Automatic ash extraction system	20
2.14 Installing the fuel outfeed system	22
2.14.1 FLEX system	22
3 Outside-temperature based controller	26
4 Electrical connections	27
4.1 Electrical connections to the heating system	27
4.2 Wiring requirements	28
4.3 Electrical connections	29
5 Final checks/Commissioning	32
6 Standards/Regulations	33
7 Plumbing diagrams	34-45
8 Technical data	46-47
8.1 PRO-Flex 175/250	46
8.2 FLEX outfeed system	47

1 Introduction

1.1 Safety instructions

GUNTAMATIC heating systems represent state-of-the-art technology and meet all applicable safety regulations. Incorrect installation can endanger life and limb. Heating boilers are combustion systems and are potentially dangerous if handled incorrectly. Installation, commissioning and servicing must, therefore, only be carried out by adequately qualified technicians observing all regulations and the manufacturer's instructions.

1.2 Guarantee

The manufacturer's guarantee is subject to correct installation and commissioning of the heating system. Defects and damage caused by incorrect installation, commissioning or operation are not covered by the guarantee. To ensure that the system functions as intended, the manufacturer's instructions must be followed. Furthermore, only genuine replacement parts or parts explicitly approved by the manufacturer may be fitted to the system.

1.3 Commissioning

Commissioning of the boiler must be carried out by an authorised GUNTAMATIC specialist or other qualified persons. They will check whether the system has been installed according to the plans, adjust the system settings as required and explain to the system operator how to use the heating system.

1.4 Site requirements

When establishing the site requirements, it is absolutely essential to take account of the locally applicable planning, building and implementation regulations and the dimensional specifications in the fitting guidelines, installation examples and technical data. Compliance with the locally applicable regulations and the correct implementation of the measures required on site are solely the responsibility of the system owner and are a requirement of the manufacturer's guarantee. GUNTAMATIC provides no guarantee of any kind for any type of site work. Without making any claims as to completeness or non-applicability of official requirements, we recommend the following specifications based on the Austrian Guidelines pr TRVB H 118:

1.5 Quality management

QM for wood-fired heating systems

Experts from Switzerland, Germany and Austria have drawn up a joint set of quality standards for wood-fired heating systems. The aim is to ensure that the required quality standards are specified and tested in projects involving several different companies.

<u>Information:</u>	<u>Austria:</u>	www.qmholzheizwerke.at www.qm-heizwerke.at www.umweltfoerderung.at
	<u>Germany:</u>	www.qmholzheizwerke.de
	<u>Switzerland:</u>	www.qmholzheizwerke.ch www.holzenergie.ch

2 Planning and installation

2.1 Fire safety

Important

The fire safety requirements applicable at the installation site of the heating system must be observed.

Compliance with those requirements is subject only to verification by the operator. Verification during commissioning is not provided for.

National regulations

Austria:

State legislation of the federal states
Technical Directive on Preventative Fire Safety prTRVB H118

Germany:

Standard boiler regulations (M-FeuVO)
Hessen and Saarland – in these states §16 FeuVO Hessen applies

Switzerland:

Fire safety regulations (www.vkf.ch)

Other export countries:

Relevant fire safety authority

Recommendation

Compliance with the applicable local fire safety regulations is compulsory and takes precedence over the GUNTAMATIC minimum fire safety requirements. Where there are no specific local fire safety requirements in force, the GUNTAMATIC minimum fire safety requirements should be precisely followed.

Minimum fire safety requirements

Boiler room

Floor of concrete construction, either bare or tiled. All materials for floor, walls and ceiling must be fire-resistant to F60 rating.

Boiler room door: The boiler room door must be a Class T30 fire door which opens in the direction of escape, is self-closing and lockable. Connecting doors to the fuel storeroom must also be Class T30 fire doors, self-closing and lockable. There must be no direct connection to rooms in which flammable gases or liquids are stored (e.g. garage).

Fuel storeroom The same minimum fire safety requirements apply as for the boiler room.

Storeroom doors/hatches: storeroom doors/hatches must be fire safe to Class T30, self-closing and lockable. There must be a warning sign carrying the message "Do not enter when feeder system is running" attached to the storeroom door/hatch.

Fireproof collars: If the storeroom is not situated directly adjacent to the boiler room, a fireproof collar must be fitted to the extraction and air return pipes at their wall exit points from the boiler room. If the outfeed auger goes directly into the boiler room, it is factory fitted with a special fire safety lining. No additional fireproof collars are required on the air pipes. If the outfeed auger is sited entirely inside the storeroom (i.e. if the outfeed auger does not extend out of the storeroom), fireproof collars must similarly be fitted to the extraction and air return pipes at their wall exit points from the storeroom.

Filler pipes: filler pipes through rooms where there is a fire risk must be provided with Class F90 cladding.



Safety systems

In Austria various safety systems are required according to prTRVB H118 (Technical Directive on Preventative Fire Safety) depending on the system design, heat output, fuel type and fuel store size.

Pellets

Burn-back prevention device

(Rotary feeder, fire-proof laminate in outfeed auger inspection cover)

Burn-back inhibiting facility

(Rotary feeder, fire-proof laminate in outfeed auger inspection cover)

For heating systems with a heat output >150kW or fuel storerooms >50m³, differences from this directive in the form of special designs are permissible if they provide at least the same degree of fire safety as required by this directive.

Any differences are to be examined by a testing agency and documented in an inspection report.

2.2 Boiler room requirements

<u>Combustion air supply</u>	The depression in the boiler room must not be more than 3 Pa (0.3mm H ₂ O). The air vents for boiler rooms where the fuel heat output is 50 kW or more must have a clear, net cross-sectional area of at least 5cm ² per kW of rated output. The air supply ducting must connect directly to the outside and if the ducting passes through other rooms, it must be jacketed to Class F90. On the outside of the building, air vents must be covered by a protective grille with a mesh size of >5mm. The supply of combustion air should, if possible, enter at floor level in order to prevent cooling of the boiler room.													
<u>Electrical installation</u>	The lighting and the electrical wiring in the boiler room must be permanently installed. For every heating system there must be a clearly marked lockable heating master switch and an emergency off switch in an easily accessible position outside the boiler room, close to the boiler-room door.													
<u>Fire extinguisher</u>	A hand-held fire extinguisher (6kg gross weight, EN3) must be mounted outside the boiler room near the boiler-room door.													
<u>Protection against freezing</u>	The boiler room, pipes carrying water and any district heating pipes must be protected against freezing.													
<u>Minimum room size</u>	<table border="0"> <tr> <td style="padding-right: 10px;">1 module</td> <td>min. L* 270 x W* 330cm</td> <td>(accessible on left-hand side)</td> </tr> <tr> <td></td> <td>min. L* 270 x W* 430cm</td> <td>(accessible on one side and at rear)</td> </tr> <tr> <td style="padding-right: 10px;">2 modules</td> <td>min. L* 540 x W* 330cm</td> <td>(each module accessible on left-hand side)</td> </tr> <tr> <td></td> <td>min. L* 440 x W* 430cm</td> <td>(modules accessible on one side and from rear)</td> </tr> </table> <p>L * = Boiler room length from left to right – boiler(s) viewed from the front W * = Boiler room width from front to back – boiler(s) viewed from the side</p>		1 module	min. L* 270 x W* 330cm	(accessible on left-hand side)		min. L* 270 x W* 430cm	(accessible on one side and at rear)	2 modules	min. L* 540 x W* 330cm	(each module accessible on left-hand side)		min. L* 440 x W* 430cm	(modules accessible on one side and from rear)
1 module	min. L* 270 x W* 330cm	(accessible on left-hand side)												
	min. L* 270 x W* 430cm	(accessible on one side and at rear)												
2 modules	min. L* 540 x W* 330cm	(each module accessible on left-hand side)												
	min. L* 440 x W* 430cm	(modules accessible on one side and from rear)												
<u>Minimum room height</u>	H 250cm (ideally 280cm)													
<u>Clear access opening</u>	W 150cm x H 230cm (boiler delivered pre-assembled on pallet) W 125cm x H 200cm (boiler delivered in multiple sections) W 90cm x H 200cm (all attached components must be removed)													
<u>Dimensions w/o packing</u>	Heat exchanger	L 160 x W 90 x H 200cm												
	Base box	L 160 x W 90 x H 70cm												
		(all attached components must be removed)												

Installation site

Plan for positioning the module(s) as close as possible to the flue to avoid having a long flue connecting pipe. For servicing purposes and for emptying the ash box, the module should ideally be accessible from the left or from the rear left. Should it be necessary due to the circumstances of the site to position the module with its left side against the wall, the ash box can only be emptied from the rear. With this arrangement, it must be possible to access the ash box from the right-hand side of the boiler for removal.

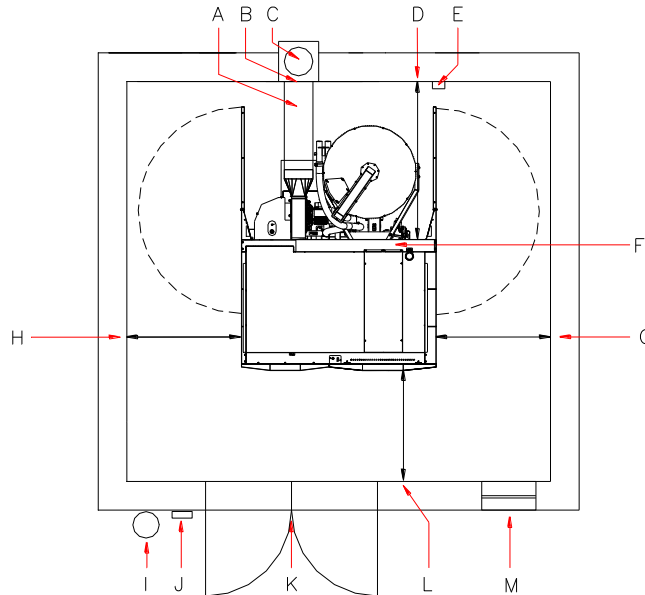

- A** → Installation option with draught regulator/pressure-surge compensator in flue connecting pipe
(As close as possible to junction with flue – observe local regulations – possibility of dust generation)
- B** → Installation option with flue draught regulator/pressure-surge compensator in flue
(Approx. 50cm below junction with flue – observe local regulations)
- C** → Flue (refractory flue that is insusceptible to damp recommended)
- D** → Clearance at rear 1.3m possible (if clearance at left is at least 1m)
 → 2.3m if clearance at left is less than 1m or if several modules
 are placed adjacent to one another
- E** → Drain for safety valves and temperature relief valve
- F** → Mains power connection
- G** → Clearance at right 0cm possible (if clearance at left and at rear is at least 1m)
 → 1m if clearance at left is less than 1m
- H** → Clearance at left 0cm possible (if clearance at right and at rear is at least 1m)
 → 1m if clearance at right is less than 1m
- I** → Fire extinguisher (6 kg gross weight to EN3)
- J** → Emergency off switch
- K** → Fire door (Class T30 lockable and self-closing)
- L** → Wall clearance at front at least 1 m
- M** → Combustion air inlet (5cm² per kW output)

2.3 Flue requirements

The flue must be matched to the system in order to ensure economical and trouble-free operation.

Important



Use only heat-insulated fireclay flues that are insensitive to damp.

The flue gas temperature may be less than 100°C when the boiler is operating at less

The system must only be connected to the flue if the flue meets the legal requirements and the technical specifications. The flue must be matched to the boiler output and dimensioned in accordance with DIN 4705. In order to be able to accurately dimension the flue, the calculations must be based on the flue gas figures. When designing new flues, high thermal insulation chimneys (DIN 18160 T1) or suitable **refractory flues** that are insusceptible to damp and have general building regulation approval should be used.

If two or more heating modules are to be connected to a flue, the flue inspector concerned should always be consulted beforehand. If the flue inspector has no concerns, the flue must be dimensioned and executed according to the legal requirements and the technical specifications based on a calculation by the flue manufacturer.

Note It is always advisable to involve those responsible for approving the flue system early on in the planning phase.

Flue height

The minimum flue height is 5 - 10m depending on boiler output. The flue must terminate at least 0.5m above the highest part of the building. In the case of flat rooves, the flue must terminate at least 1.5m above the surface of the roof.

Flue diameter

The flue must be matched to the boiler output. The following details are guide figures and can be used for planning purposes. However, we recommend that the flue dimensions are calculated precisely by an expert.

PRO 175/250	eff. height over	6m	D=250mm
	eff. height under	6m	D=300mm

Flue dimensioning data

Dimension the flue for rated output.
(Averaged figures with used heat exchanger)

Rated output

Type	Flue gas temp.	CO ₂	Mass flow rate	Required draught
PRO 175	150°C	12.0%	0.136 kg/s	10 pascals
PRO 250	180°C	12.0%	0.177 kg/s	10 pascals

Sub-maximum output

Type	Flue gas temp.	CO ₂	Mass flow rate	Required draught
PRO 175	110°C	10.0%	0.046 kg/s	2 pascals
PRO 250	130°C	10.0%	0.046 kg/s	2 pascals

2.4 Fuel store requirements

Note



Your attention is drawn to the fact that the relevant national regulations (e.g. ÖNORM M7137, VDI 3464, ...) in respect of storeroom safety are to be strictly observed.

Situation

The fuel is delivered by a tanker lorry. The storeroom and/or the filler-pipe connections must be arranged so that they can be reached by a hose no longer than 30m from the tanker lorry.

Estimating annual requirement

Calculation is based on the following annual fuel requirements per kilowatt of building heat demand:

→ Per kW/year approx. 0.65 m³ = approx. 450kg pellets

Storeroom configuration

The store room should ideally be rectangular and no wider than 3.5m. The narrower the storeroom, the less dead space there is. With a fuel outfeed system, the usable storeroom volume is approx. 2/3 of the total storeroom volume.

Storeroom ventilation

Storerooms and bunkers/hoppers must be ventilated to prevent the build-up of potentially fatal concentrations of CO. The air vents must connect to the outside and ensure that there is circulation of air between the storeroom and the outside. If the natural convection is insufficient, adequate technical means must be provided.

If the filler pipes do not open to the outside, ventilation via a separate air vent must be provided. Measures must be taken to ensure that rainwater cannot enter the storeroom through the air vents.

Rooms containing fuel storage hoppers made of air-permeable fabric must have an air vent opening to the outside. An air vent cross-sectional area of 200cm² is sufficient in this case.

For storerooms under 30t capacity, the requirements are satisfied if:

- the filler pipes open to the outside and ventilation can be achieved by means of at least 2 vented filler caps;
- the clear diameter of 2 vent pipes is at least 90mm each;
- the net clear cross-sectional area of the air vents of both filler/vent pipes up to 2m in length is at least 40cm² and for pipes over 2m long at least 60cm².

The total vent cross-sectional area of 2 filler caps in our filler set is 60cm².

For storerooms over 30t capacity, the requirements are satisfied if:

- either a combination of natural and mechanically assisted ventilation based on CO sensing is used or a state-of-the-art forced ventilation system for elimination of the CO hazard is installed. If the natural ventilation is insufficient, a forced ventilation system that is activated when the CO concentration becomes too high must be installed.

<u>Power outlet box</u>	A 230V/16A power socket for the tanker lorry's extractor fan should be provided in the immediate vicinity of the filler pipe connections. There is a power outlet box available from the GUNTAMATIC accessories range (Art. no.: H00-061). It includes a power socket which must be wired to a 16A circuit-breaker on site. The door contact switch included is to be wired to the boiler circuit board enabling switch (terminals 22-23) and shuts off the heating system as soon as the power outlet box is opened.
<u>Access doors/hatches</u>	Above-ground fuel stores must be provided with a door or hatch that opens outwards. So that the fuel cannot run out if the fuel store is opened by mistake, the inside of the access door/hatch opening must be covered with boarding (which must be removable from the outside). Due to the risk of injury when the system is in operation, access doors/hatches must be lockable and kept locked when the system is in operation. There must be a warning sign carrying the message "Do not enter when feeder system is running" attached to the access door/hatch.
<u>Electrical equipment</u>	Electrical equipment is prohibited in the fuel storeroom.
<u>Filler set</u>	<p>The filler pipes must be earthed.</p> <p>At least 2 filler pipes must be installed – minimum separation 0.5m – maximum separation 1.5m.</p>
<u>Installation in cold areas</u>	<p>If installed in cold areas, vacuum pipes and outfeed unit must be adequately insulated (frost-proof).</p> <p>Risk of condensation formation</p>
<u>Structural requirements</u>	The enclosing walls must be capable of withstanding the possible static loads created by the stored fuel and the pressure when filling the fuel store.
<u>Wall penetration</u>	If there is an auger conveyor passing through the storeroom wall, the gap in the wall must be filled with mineral wool and sealed by means of the non-contact (sound insulation) finishing plates provided.
<u>Filling the fuel store</u>	When pressure-filling the fuel store from a tanker truck, the air pumped in must be drawn out of the fuel store. Extraction is the responsibility of the supplier.
<u>Damp-proofing</u>	The fuel must be protected against contact with water or damp floors/walls. The storeroom must remain dry all year round. If there is a risk of temporarily damp walls, fitting a back-ventilated facing to the walls and lining them with wooden material may be required.

2.5 Planning examples for the fuel store

Information Every heating system is supplied with 2 fuel outfeed augers and a vacuum hose changeover unit. The only additional requirement is to run 2 vacuum hoses from the changeover unit to the fuel hopper on the boiler.

Planning guide:

- Provide one filler set with rubber deflector guard per outfeed auger
- Maximum distance between filler pipe connections 1.0m
- Maximum storeroom width 3.5m per outfeed auger
- Maximum outfeed auger length 5.0m
- Plan storeroom ventilation

Recommended fuel store size:

- The store should be large enough for at least one lorry load (approx. 20t) + 20% spare capacity
- Rule of thumb: approx. 2/3 of the total storeroom volume can be utilised for pellet storage

Example calculation for minimum fuel store size:

Lorry load + 20% spare capacity: $20t + 20\% = 24 \text{ tonnes}$
Pellets volume = Lorry load + 20% spare capacity / 0.65 t/m³ = 37m³
Required storeroom volume: = Pellets volume / 0.66 = 56m³
Equates to a storeroom with e.g. the following dimensions: (W) 5.5 x (L) 3.5 x (H) 2.9 m

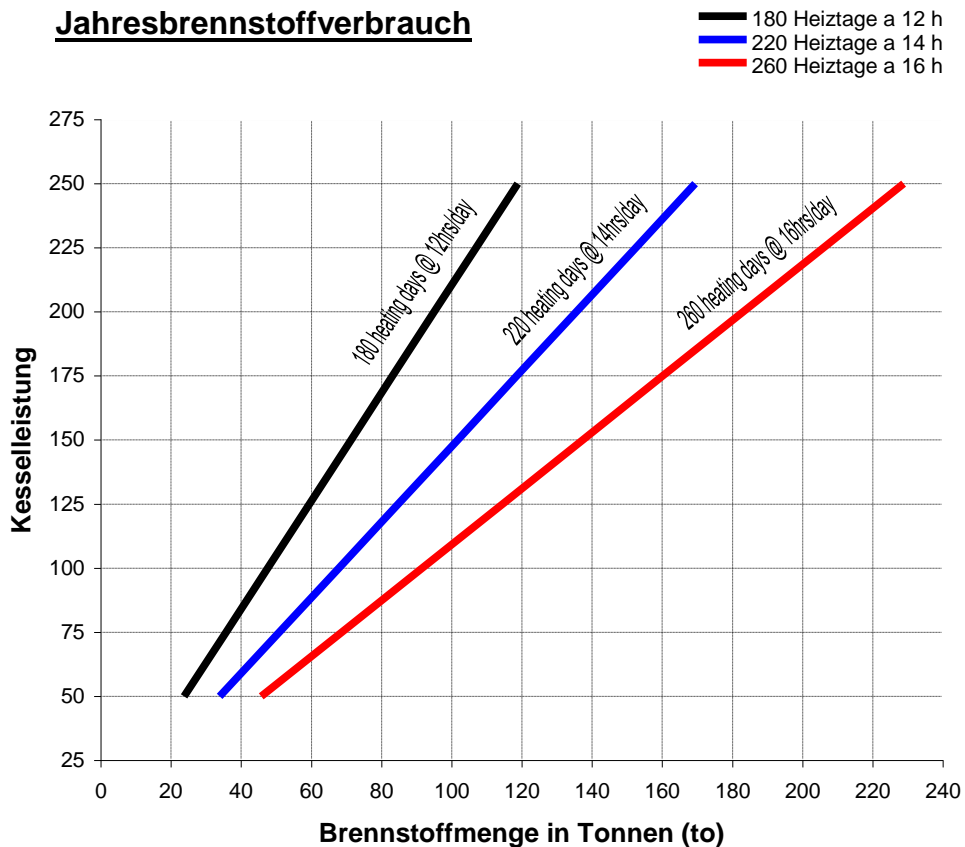

Planning example 1 The fuel store is directly adjacent to the boiler room. The maximum length of the outfeed auger is 5m. The maximum vacuum pipe length is 25m. Vacuum pipe installed only in boiler room. No fireproof collars are required.

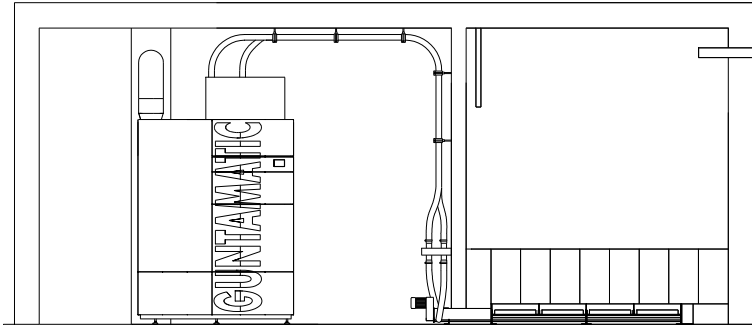

Planning example 2 The fuel store is in another part of the building. The maximum length of the outfeed auger is 5m. The maximum vacuum pipe length is 25m. Where the vacuum pipes pass through the wall, a fireproof collar must be fitted to each vacuum pipe on the boiler-room side.

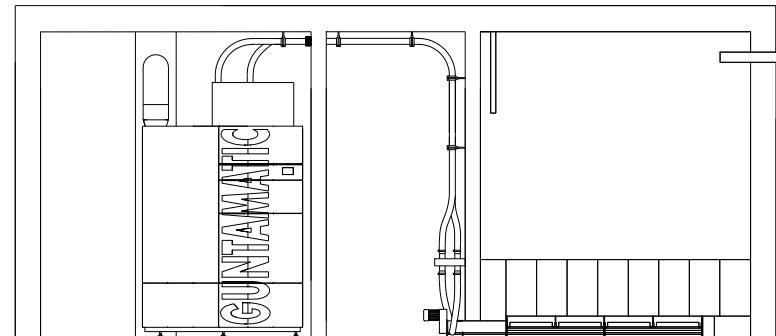

Planning example 3 The fuel store is one floor higher than boiler room. The maximum length of the outfeed auger is 5m. The maximum vacuum pipe length is 25m.



Caution: Have the building checked by a structural engineer to make sure it is capable of supporting the static loads involved.

Where the vacuum pipes pass through the wall, a fireproof collar must be fitted to each vacuum pipe on the boiler-room side.

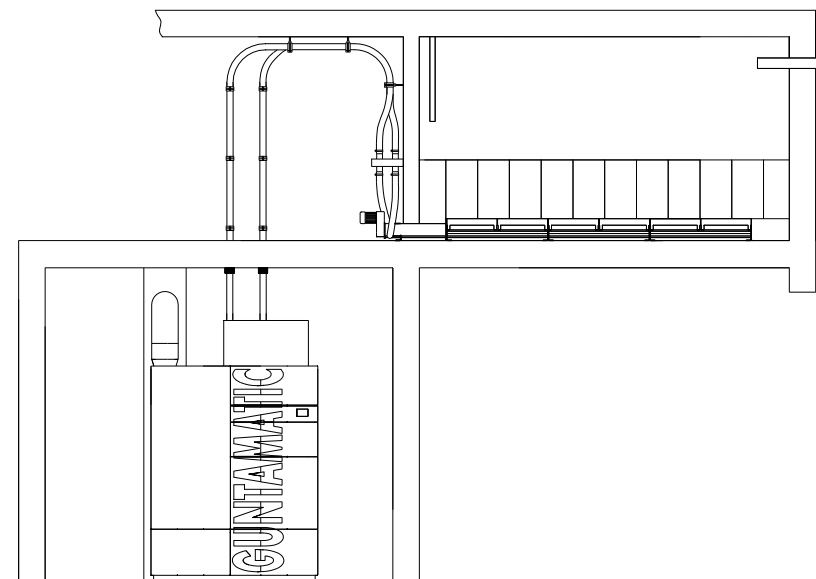

2.6 Delivery

The boiler system is delivered packed in multiple sections wrapped in foil. Please check that the delivery is complete according to the delivery note and in perfect condition.

Deficiencies

Please make a note of the deficiencies identified directly on the delivery note and contact the supplier, heating installer or our Customer Service.

2.7 Carrying to installation site

The individual system components are delivered on wooden pallets and can be lifted and carried to the installation site using a pallet truck.

2.8 Positioning and aligning the boiler

Keep to the minimum wall clearances specified by the system planner and manufacturer. If important details are missing, please ask our Technical Support. Position the system as close as possible to the flue to avoid having a long flue connecting pipe. The system must be accessible from the left or right side.

Clearance at left

- 0cm possible if clearance at right and at rear is at least 1m
- 1m if clearance at right is less than 1m

Clearance at right

- 0cm possible if clearance at left and at rear is at least 1m
- 1m if clearance at left is less than 1m

Clearance at front

- at least 1 m

Clearance at rear

- 0cm possible if clearance at left is at least 1m
- 1m if clearance at left is less than 1m or if several modules are placed adjacent to one another

Floor clearance Set the clearance between the boiler base and the floor to the required minimum of 35mm by unscrewing the adjustable feet on the boiler base.

Set the boiler at a slant

Unscrew the rear adjustable feet slightly further so that the boiler is slightly **higher at the rear**. That will allow the air inside the boiler to escape easily when the system is filled.

2.9 Plumbing connections

- A** → Temperature-relief heat exchanger, 3/4"
- B** → Boiler sensor, STL
- C** → Heating flow, 2"
- D** → Sensor for temp. relief valve, 1/2"
- E** → Heating return, 2" (run pipe upwards)
- F** → Drain, 2"

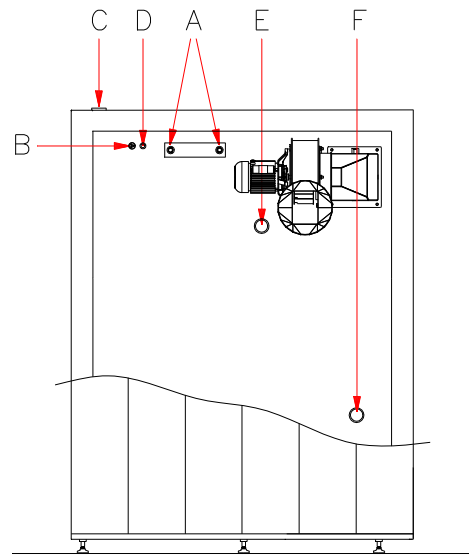

Temperature-relief heat exchanger

The maximum permissible boiler operating temperature is 110°C. In order to prevent the maximum allowable operating temperature being exceeded, connection of a temperature-relief valve conforming to Austrian standard ÖNORM 8131 and DIN 4751 and with a response temperature of 95°C is required. The supply pressure must be at least 2 bar but no more than 6 bar.

- A** → Cold water inlet
- B** → Sensor for temp. relief valve, 1/2"
- C** → Temp. relief valve, 95°C

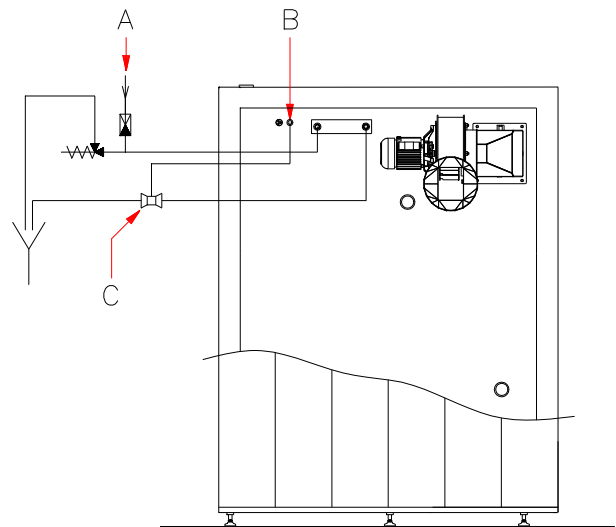

Thermal store Installing a thermal store is absolutely imperative as it helps to balance the load within the system so that the boiler can be operated with a substantial degree of modulation. In larger systems with multiple modules, a sufficiently large thermal store must be used in order to balance out heating load spikes and to assist sequential boiler control. The minimum thermal store size is stated on the plumbing diagram in each case.

Note If 5-sensor thermal store management is activated, it is imperative that a return mixer valve controlled by the boiler controller is used.

Important Compliance with Stage 2 BIMSCHV (Germany) requires a thermal store capacity of at least 20 litres/kW.

Return boost The boiler return temperature must be at least 55°C and must be guaranteed by a return boost set as per the system plumbing diagram. If this requirement is not complied with, there is an increased risk of corrosion and guarantee entitlement will be lost as a result. Connect the return boost set precisely as specified in our plumbing diagrams.



Important:

The dimensioning of the return boost set is designed for the configurations shown in GUNTAMATIC plumbing diagrams. If additional components such as heat meters are incorporated in the system plumbing, or if the overall thermal store pipe run (flow and return) is more than 25m, re-dimensioning of the boiler charging pump (HP0) may be necessary.

Important Use the 2" piping shown in the plumbing diagrams as a minimum or large-sized components with the lowest possible flow resistances.

Expansion vessel The boiler operates in a sealed heating system and must be provided with an automatic pressure maintenance system or an expansion vessel for pressure compensation. To calculate the expansion volume, the volume of the system when cold must be known. Please select the expansion vessel on the basis of the manufacturer's specifications. The expansion volume is calculated as follows:

System volume x Expansion factor x Additional allowance factor

- Expansion factor for wood-fired boilers = 0.03
- Additional allowance factor = 1.5 for systems over 150 kW

Example calculation: 10,000 litres x 0.03 x 1.5 = 450 litres

Plastic piping If plastic piping for underfloor heating or district heating pipes are connected, they must be protected against excessive temperatures by using a limiting thermostat for the circulation pumps.

Pump selection The choice of pump must be made by the installer or building technology planner on the basis of the friction data, the pipe cross-sectional area and the required delivery pressure for the piping system planned.

2.10 Filling and bleeding the system

The system is filled with water from the domestic supply. Please note the guidelines on "Corrosion and boiler protection in heating and domestic water systems".

Water quality

The water quality of hot water systems with flow temperatures of max. 100°C is subject to VDI 2035. According to VDI 2035 Part 1, "Avoiding damage to hot water systems", which comply with EN12828, the first-fill and replenishment water, must be conditioned (preferably softened) if the following overall hardness limits [°dH] according to total heat output (kW) are exceeded:

- < 50kW: with circulating flow heaters, if °dH > 16.8
- 50 to 200 kW: if °dH > 11.2
- 200 to 500 kW: if °dH > 8.4
- > 500kW: if °dH > 0.11

Water heater

If a water heater is also used in addition to the GUNTAMATIC boiler, it should be filled according to the installation instructions for it.

Filling the system

- Match the pressure of the system when cold to the air charge pressure of the expansion vessel
- Check the operating pressure on the pressure gauge

Bleeding the system

- Switch off and bleed circulation pumps.
- Bleed boiler by opening the bleed valve on the boiler and allowing air to escape until water runs out.
- Bleed radiator heating system (if present) by opening the bleed valve on every radiator and allowing air to escape until water runs out.
- Bleed underfloor heating system (if present) by opening each heating circuit and flushing through thoroughly until there are no more air bubbles in the heating circuit pipes.
- **Important:** perform sequence in the correct order!
Start bleeding in the cellar or on the ground floor and finish in the attic.
- Check the system operating pressure on the pressure gauge and add more water if necessary.
- Restart circulation pumps.



**Only systems that have been properly bled
guarantee effective conveyance of heat.**

2.11 Connecting the flue

The boiler is connected to the flue by means of a flue connecting pipe which must be gas-tight and insulated between the heating boiler and the chimney (insulation thickness 50mm).

Flue connecting pipe

The following diameters should be used:

- PRO 175/250 dia. = 250mm

Flue connecting pipes longer than 4m or with more than 3 bends:

- PRO 175/250 dia. = 300mm

The hole in the wall for connecting the flue pipe must be lined with a built-in double-skinned lining tube or fireproof material. The flue connecting pipe must rise upwards from the boiler to the flue at an angle of at least 6° and be connected with gas-tight joints. An inspection cover must be provided for cleaning the flue connecting pipe.

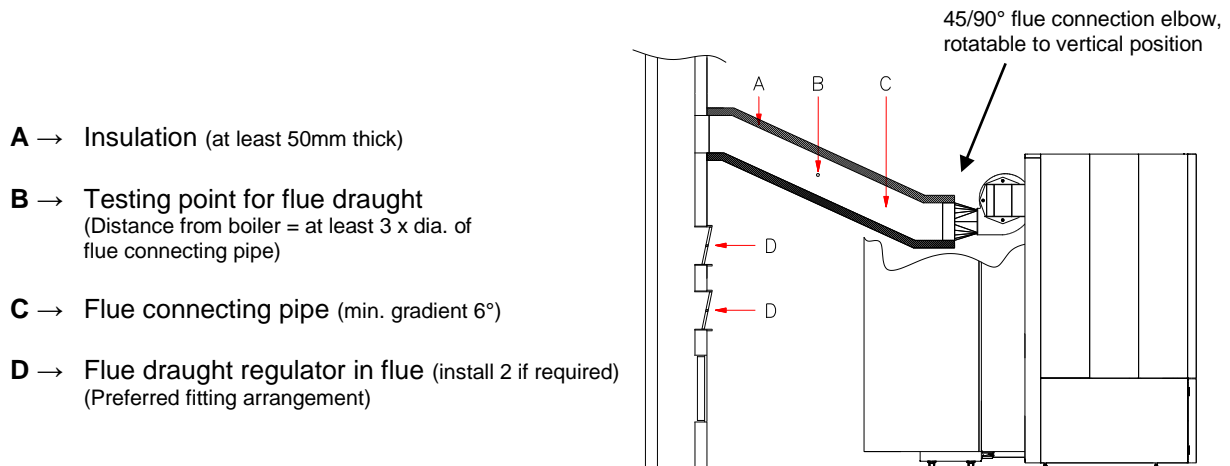

Note:

- The flue connecting pipe must be gas-tight
- A flue draught regulator with pressure-surge compensator must be fitted
- Insulate the flue connecting pipe
- Do not brick in the flue connecting pipe (noise transmission)
- The flue connecting pipe must not extend into the flue

2.12 Energy-saving flue draught regulator/pressure-surge compensator



Fitting an energy-saving flue draught regulator/pressure-surge compensator is absolutely imperative.

Fit 2 if necessary!

Purpose

- To ventilate the flue when the system is not in operation
- To compensate for pressure surges
- To regulate and limit the flue draught

Fitting requirement

The energy-saving flue draught regulator must be fitted in accordance with the local regulations, preferably in the flue approx. 0.5m below the point where the flue connecting pipe joins or alternatively in the flue connecting pipe close to its junction with the flue.

Flue draught setting:

- Adjusting the flue draught is only of any use at outside temperatures below +5°C.
- The system must have been in operation for at least an hour
- Ensure there is sufficient demand for heat for the boiler to be run at rated output for at least 15 minutes
- Measure the flue draught between the boiler and the flue draught regulator (distance of measuring point from boiler ideally 3 x flue diameter from connection between boiler and flue connecting pipe).

Flue draught

The flue draught should not differ by more than +/- 3 pascals from the figure specified in the flue dimensioning data. If the flue draught cannot be reduced to the required figure, either a larger draught regulator should be fitted or an additional flue draught regulator installed.

Too much flue draught

May cause the flue gas temperature to increase and accelerate combustion as a result. Poor boiler output adjustability, increased dust discharge and malfunctions can result.

Too little flue draught

Performance problems, incomplete combustion and malfunctions when operating below rated output can result.

2.13 Automatic ash extraction system



The information below is provided primarily for system planning purposes. Full details of installing the automatic ash extraction system are provided in the separate installation and operating instructions supplied with the system.

An optional automatic ash extraction system is available. The extraction system is built into the boiler and conveys the accumulated ash via flexible metal vacuum pipes (maximum length of 20m vacuum pipe and 20m air return pipe) to a large-capacity wheeled ash bin. Ash removal is fully automatic.

Retrofitting

The automatic ash extraction system can also be retrofitted at a later date.

Ash bin dimensions

- A** → 1530mm
- B** → 590mm
- C** → 720mm
- D** → 1070mm

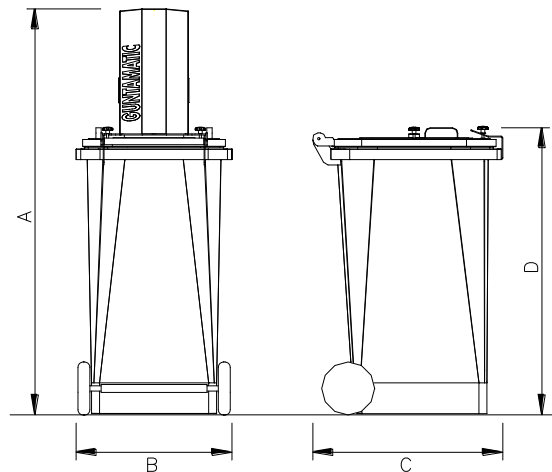

Siting the ash bin

If possible, plan for placing the ash bin at ground level in the boiler room near the boiler. A fundamental requirement for the siting of the ash bin is good ventilation of the room in which it is placed. The ash bin must be sited permanently with a minimum clearance of 25cm from combustible materials and on a non-combustible base that extends at least 5cm beyond the bin on all sides.

Locations where the ash bin must not be installed

- Garages
- Outdoors (unless protected from frost and ventilated)
- Rooms used for living purposes
- Storerooms for flammable liquids and gases

Locations where the ash bin may be installed

→ In the boiler room

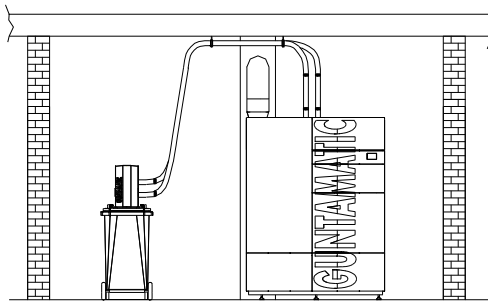

→ In an adjoining room

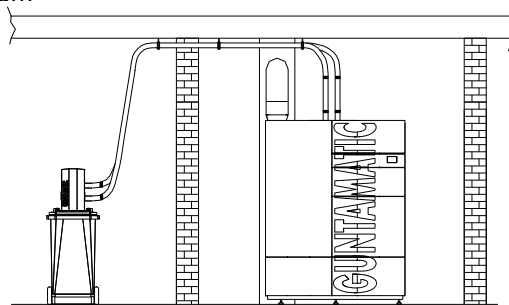

→ In a room separated by an adjoining room

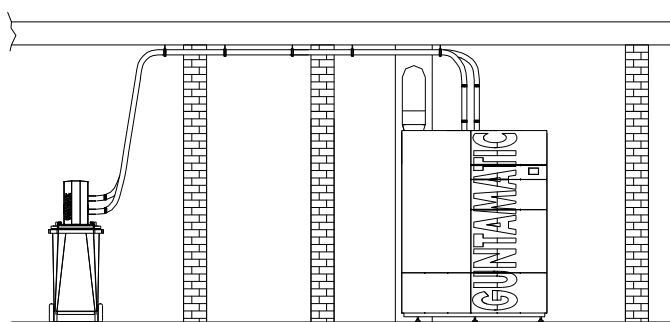

Vacuum pipe routing through fire containment zones

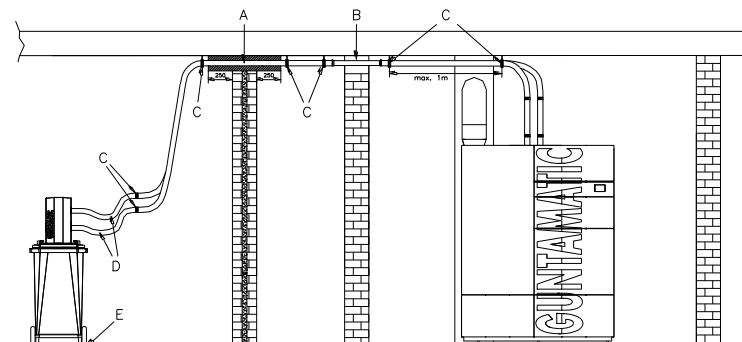

- A** → Passage through wall using mineral wool sleeves
- B** → Passage through wall using steel tube built into wall
- C** → Fireproof pipe bracket 54-60 ZUS (maximum spacing 1m)
- D** → Metal vacuum hoses (spacing at least 10cm)
- E** → Non-combustible base

2.14 Fuel outfeed installation

2.14.1 FLEX system



Important → Ensure the inlet opening is on the correct side.

A → Conveying direction

B → Inlet opening always this side

C → Direction of rotation

D → Scraper

E → Floor mounting plate

F → Check dimension 56mm

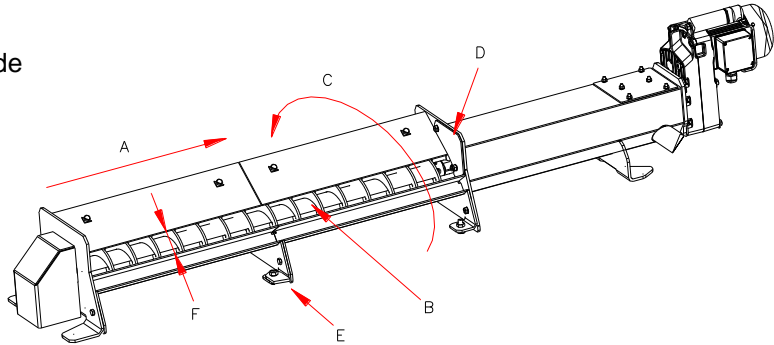

Fig. 1

Installing the outfeed augers

1. Feed the drive unit (5, Fig. 2) of the fuel outfeed auger through the hole (W 330mm x H 250mm) in the storeroom wall.
2. Depending on the auger length, join the required auger sections complete with conveyor trough (9, Fig. 2) to the drive unit (5, Fig. 2) from the storeroom end.

Important: join the auger sections together so that the auger slope continues evenly.

Afterwards securely fix the auger trough flange joint using the M08 x 30 bolts supplied (8, Fig. 2) and locking washers. Make sure that the auger troughs are joined together so as to be perfectly flush on the inside. Screw the flange plate (10, Fig. 2) and bearing on the end of the outfeed auger (if not pre-fitted).

3. Unscrew the grub screws (11, Fig. 2) on the bearing and attempt to push the auger towards the drive unit as far as it will go. Then re-tighten the grub screws.
4. **After assembly:** rotate the auger to check that it is running true (maximum allowable auger run-out in the centre is 3mm).
5. Position the assembled outfeed auger so that the drive unit extends at least 42cm (see Fig. 2) out of the storeroom wall.
6. Screw the conveyor trough securely to the storeroom floor.

Important: the conveyor trough must be aligned flush using the floor mounting plates (E, Fig. 1) and screwed securely to the floor so that it is straight and has no sags or humps.

7. Fill the gap (6, Fig. 2) in the wall around the conveyor with mineral wool. Cover the hole on both sides of the wall with the masking plates supplied (7, Fig. 2), fitting them so that they do not touch the conveyor.

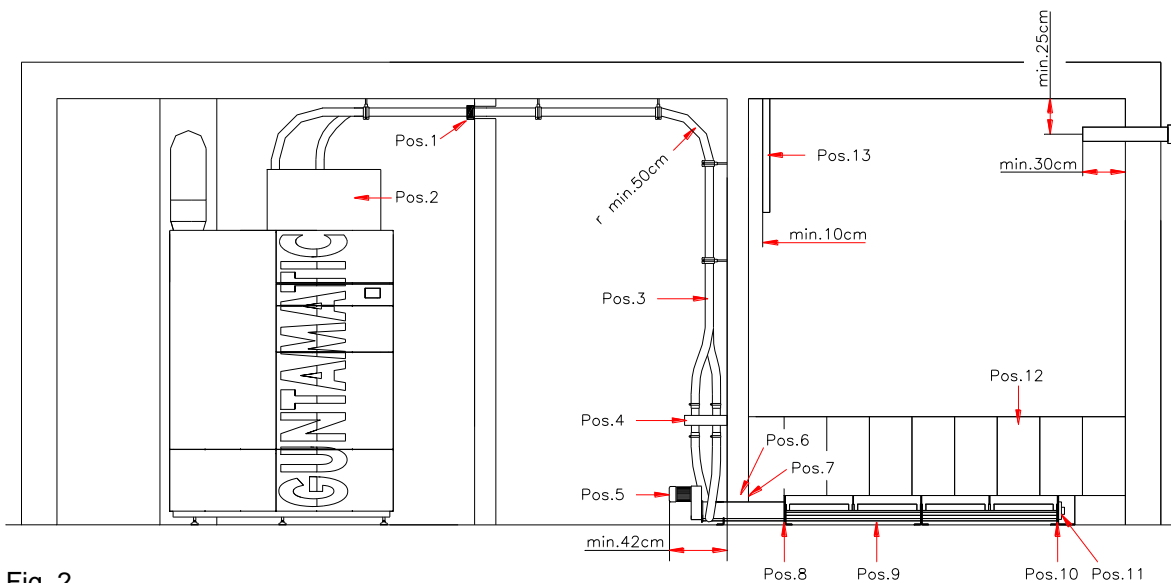

Fig. 2

Fitting the vacuum extraction and air return pipes

1. The vacuum extraction and air return pipes (3, Fig. 2) between the heater module (2) and the hose changeover unit (4) should be routed so that the bends are as gradual as possible (minimum curvature radius 50cm) and connected to the hose changeover unit. There should also be a vacuum extraction and air return pipe – similarly routed with gradual bends – running from each outfeed auger to the hose changeover unit and connected to it.

Important: Hose bends with a curvature radius of under 50cm can cause obstructions in the fuel supply system. In addition, the vacuum hoses should not sag. An adequate number of fixings should be used.

2. The vacuum and air return hoses as shown in Fig. 2 must be secured to the cyclonic separator (2), the hose changeover unit (4) and the drive unit (5) and made air-tight using the pipe clips supplied.

Important: Air leaks from the hose connections can cause problems in the fuel supply system.

3. The air hoses for the fuel delivery system should not be routed outdoors or through cold rooms.

(Possibility of condensation formation – insulate the vacuum hoses adequately.)

Important: Condensation in the vacuum hoses can cause problems in the fuel supply system.



Important →

All vacuum hose and air return pipe ends must be earthed.

To do so, expose approx. 7cm of the copper wire at the end of the hose and fold over the earthing wire into the hose by approx. 3cm. Fit the hose over the connection spigot in that way and screw it firmly in place. Make sure there is good contact between the earthing wire and the connection spigot. If necessary file the paint off the connection spigot.



Important →

The fuel outfeed augers must be completely emptied and vacuumed out every 3 years at least.



Important → For large-scale pellet stores, a specially solid substructure for the boarding in the storeroom must be constructed.

Please follow our recommendations as shown in Fig. 3 or else have a sufficiently strong structure installed by a specialist. 1m³ of pellets weighs approx. 0.65 tonnes!

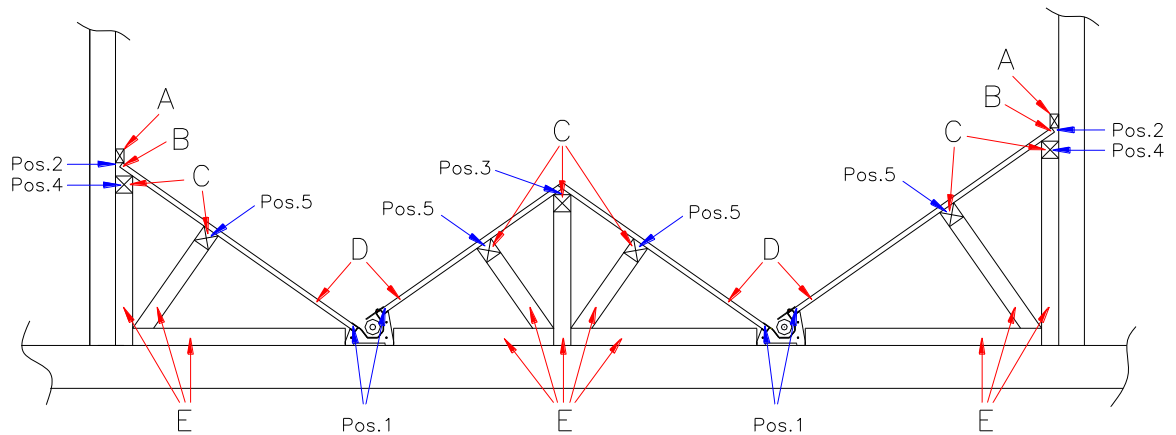

Fig. 3 → Viewed from auger drive unit facing towards storeroom

- A** → Cross-batten (e.g. planed roof batten) **D** → Planned timber boards or blockboard panels (3cm thick)
B → Cut timber boards/blockboard panels 3cm short **E** → Substructure supporting timbers (10cm x 10cm battens)
C → Horizontal reinforcing timber (10cm x 10cm batten)

Fitting the boarding in the storeroom

1. Insert a length of batten or similar into the slot for the boarding (1, Fig. 3) in order to mark the line for the 35° slope. Mark off the resulting height for the substructure on the side walls (2, Fig. 3) of the storeroom. Measure the necessary height for the substructure between the outfeed augers (3, Fig. 3) by inserting a length of batten on the left and right respectively.
2. Screw the horizontal supporting timbers (4, Fig. 3) on the left and right to the storeroom wall approx. 3cm below the slope height previously marked.
3. Support the horizontal timbers (4, Fig. 3) with vertical battens spaced at no more than 1.5m apart. If the distance between the auger and the wall is greater than 1.5 m, additional supporting battens and substructure (5, Fig. 3) must be provided.
4. Cut the boards (D, Fig. 3) from the outfeed augers to the wall on the left and right about 3cm short and fit them so that there is a small gap (2, Fig. 3) between the boards and the wall. Fit the boards between the augers as shown in our suggested structure in Fig. 3.
5. Do not screw every board in place and instead screw a horizontal batten (A, Fig. 3) to the wall across all the boards.
6. If the augers do not extend to the end of the storeroom, a 35° slope should also be constructed from the end wall to the conveyors.
7. If the conveyor sections do not reach up to the exit point through the wall, an additional substructure must be used up to the wall.

Installing the filler set

For storerooms up to a maximum width of 3.5m, installation of a single filler set with a blast guard fitted opposite is sufficient.

For wider storerooms, installation of additional filler pipes is advisable so that the fuel supplier can change over the filler hoses from the lorry. This will enable better filling of the storeroom.

Note: There must be a blast guard opposite each filler pipe on the facing wall fixed at a distance of 10cm from the wall unless the pipe concerned only extracts air from the storeroom during the filling process.

Recommendation:

Storeroom width up to 4.5m → 3 filler pipes and 2 blast guards

Storeroom width up to 5.5m → 4 filler pipes and 2 blast guards

Storeroom width up to 6.5m → 5 filler pipes and 3 blast guards

Notes on installation:

- Minimum distance from ceiling and walls 25cm.
- Required hole diameter in wall 130-150mm.
- Ensure the filler pipes are fixed firmly in place and tightly sealed. (E.g. fill gap with waterproof expanding foam filler.)
- The filler pipes must be earthed (at least 1.5mm²).
- If installed in a shaft, make sure that no water can enter the pellet storeroom via the filler pipes.

- A → PVC pipe, 150mm dia.
- B → Filler set, straight
- C → Pipe
- D → Filler set, 45° elbow

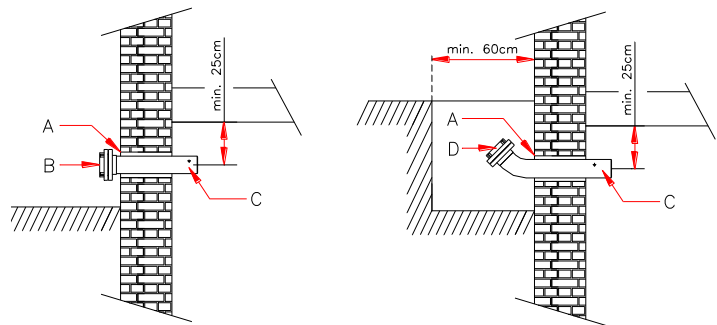

Access doors/hatches

Above-ground fuel stores must be provided with a door or hatch that opens outwards. So that the fuel cannot run out if the door/hatch is opened by mistake, the inside of the access door/hatch opening must be covered with boarding (which must be removable from the outside). Due to the risk of injury when the system is in operation, access doors/hatches must be lockable. There must be a warning sign carrying the message "Do not enter when feeder system is running" attached to the access door/hatch. The door/hatch opening must be provided with a (dust-proof) seal around its perimeter.

- A → Perimeter seal
- B → Fire door (hatch), Class T30
- C → U or Z-section framing
- D → Wooden boards (at least 3cm thick)

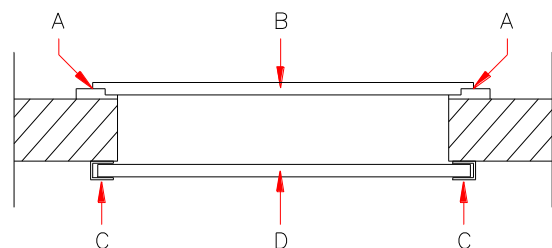

3 Outside-temperature based controller

PRO-03-00-00-01-1ADE

Only one of the options "Network system control" **OR** "Heating system control" can be activated.

Network system control Network system control is outside-temperature based and integrated in every system. Heating water can be delivered to various heating network components via supply or district heating pipes by means of "network system pumps" or "network system pumps with network mixer valves". A maximum of 3 network system pumps or 2 network mixer valves with 2 twin pumps each can be operated. Depending on the system configuration, "supplementary function" (ZU) outputs can be also used to control up to 2 hot water cylinders and a peak load boiler.

Key:

- NKP 0 = Network sys. pump 0
- NKP 1 = Network sys. pump 1
- NKP 1a = Network sys. twin pump 1a
- NKP 1b = Network sys. twin pump 1b
- MI 1 = Network mixer valve 1
- NKP 2 = Network sys. pump 2
- NKP 2a = Network sys. twin pump 2a
- NKP 2b = Network sys. twin pump 2b
- MI 2 = Network mixer valve 2
- SLP = Hot water cylinder
- ZU → WWP = Supp. HW cylinder
- ZU → EXTERN = Peak load boiler

<u>Configuration variations</u>	NKP 0 NKP 1b ZU	NKP 1 (a)	MI 1	NKP 2 (a)	MI 2	SLP NKP 2b
Diagram no. PRO-01-02-01						
Pumped network system 0 Pumped network system 1 Pumped network system 2 Hot water cylinder 0	●	●		●		●
Pumped network system 1 Pumped network system 2 Hot water cylinder 0 X = Optional item	X	●		●		●
Diagram no. PRO-01-02-02						
Network system 1 <u>mixer-valve system with twin pump</u> Network system 2 <u>mixer-valve system with twin pump</u>	●	●	●	●	●	●
Network system 1 <u>mixer-valve system with twin pump</u> Network system 2 <u>mixer-valve system with twin pump</u> X = Optional item	X	●	●	●	●	●
Network system 1 <u>mixer-valve system</u> Network system 2 <u>mixer-valve system</u> Hot water cylinder 0 X = Optional item	X	●	●	●	●	●

Heating system control (max. 3 MK261 wall controller sets per boiler possible)

One DHW cylinder, one pumped heating circuit and 2 mixer-valve circuits can be controlled. Selecting the Supplementary option allows heat to be requested from a 2nd DHW cylinder or a peak load boiler per wall controller. The option District heating mode allows the district heating functions CP or TSP to be selected.

Note If the Supplementary and District heating functions are not used, Heating circuit 0 can be used in each case as a third mixer-valve heating circuit.

Key:

- HKP 0 = Heating circuit pump 0
- HKP 1 = Heating circuit pump 1
- HKP 2 = Heating circuit pump 2
- MI 1 = Mixer valve 1
- MI 2 = Mixer valve 2
- ZU → MI 0 = Mixer valve 0 (CLOSED Command)
- ZU → WWP = Supp. HW cylinder
- ZU → EXTERN = Peak load boiler
- FL → MI 0 = Mixer valve 0 (OPEN command)
- FL → LAP = District heating function
- FL → PUP = District heating function
- FL → ERW = Heating circuit extension

<u>Configuration variations</u>	ZU	FL	SLP	HKP 0	HKP 1	MI 1	HKP 2	MI 2
Heating circuit 0 <u>pumped circuit</u> Heating circuit 1 <u>mixer-valve circuit</u> Heating circuit 2 <u>mixer-valve circuit</u> Hot water cylinder 0 X = Optional item	X	X	●	●	●	●	●	●
Heating circuit 0 <u>mixer-valve circuit</u> Heating circuit 1 <u>mixer-valve circuit</u> Heating circuit 2 <u>mixer-valve circuit</u> Hot water cylinder 0	●	●	●	●	●	●	●	●

4 Electrical connections

4.1 Heating system electrical connections

Mains connection: 400V, 50Hz, 20A (surge protector recommended)

Standard specifications:

- **BCE** Boiler control panel
- **KP** Boiler circuit board (230VAC)
- **TPM** Conveyor module (400VAC)
- **SMA** Fault signal output (24VDC 200mA)
- **STB** Safety temperature limiter
- **T1** Boiler sensor (KVT20)
- **STF** Stoker sensor (PT1000)
- **RGT** Flue gas sensor (thermocouple)
- **T-WTR** Cleaner sensor (thermocouple)
- **FW** Combustion chamber photo sensor
- **Rein-Pos** Door switch, cleaning position (15VDC)
- **TKS 1** Combustion chamber door monitor (24VDC)
- **TKS-Box** Ash box monitor (230VAC)
- **Lambda** Oxygen sensor (12VDC)
- **LFK** Air flap (24VDC)
- **BRW** Fuel valve motor (24VDC)
- Inputs for up to 5 thermal store sensors (KFT20)
- **A3** Ash extractor motor (230VAC)
- **A3 Hall** (speed monitor)
- **Rein** Cleaner motor (230VAC)
- **SZ** Flue draught fan (230VAC)
- **SZ Hall** (speed monitor)
- **Rost** Grate motor (230VAC)
- **Rost Hall** (speed monitor)
- **FÜS** Fill level (storeroom monitor)
- **A1a/A1b** Auger motor (230VAC)
- **G1** Stoker motor (230VAC)
- **ZG** Ignition fan (230VAC)
- **HP0** Boiler charging pump (230VAC)
- **RLM** Return mixer valve (230VAC)
- **RLF** Return sensor (KVT20)
- **SI-LR** Storeroom safety switch (230VAC)
- **KFR** Boiler enabling switch (230VAC)

Optional equipment:

- **VF** Flow temp. sensor (KVT20)
- **RF** Return temp. sensor (KVT20)
- **SF** Cylinder sensor (KVT20)
- **AF** Outside temp. sensor (KVT20)
- **NKP** Network system pumps (230VAC)
- **HKP** Heating circuit pumps (230VAC)
- **MI** Mixer valve (230VAC)
- **A4** Ash extractor fan (230VAC)
- **ATF** Ash bin sensor (KVT20)
- **TKS-AT** Ash bin monitor
- **A2** Feed auger (400VAC)
- **NKFR** Network system clearance (0-10V)

Resistances:

Temperature	KVT20	Temperature	PT1000
-16°C	1.434 kΩ	0°C	1.000 kΩ
-8°C	1.537 kΩ	10°C	1.039 kΩ
0°C	1.644 kΩ	30°C	1.117 kΩ
10°C	1.783 kΩ	40°C	1.155 kΩ
20°C	1.928 kΩ	50°C	1.194 kΩ
30°C	2.078 kΩ	60°C	1.232 kΩ
40°C	2.234 kΩ	70°C	1.271 kΩ
50°C	2.395 kΩ	80°C	1.309 kΩ
60°C	2.563 kΩ	100°C	1.385 kΩ
70°C	2.735 kΩ	125°C	1.480 kΩ

4.2 Wiring requirements

Surge protection

Where CAN bus cables run between different buildings, the earthing conductors of the buildings must be connected to each other for potential equalisation purposes. If the earthing conductors cannot be interconnected, a 10mm ring earth must be laid along with the CAN bus cable in the ground. The earthing conductors and ring earth must then be connected to one another.

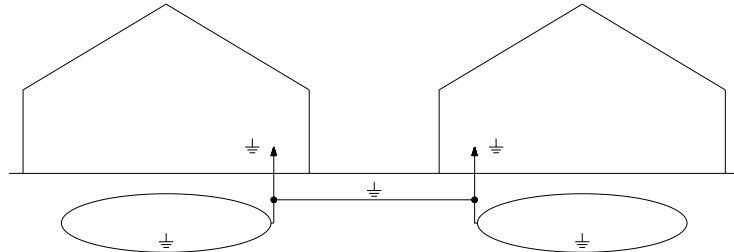

Sensor 2 x 1mm²

Analogue room stat RFF 2 x 1mm²

CAN bus connecting cable 2 x 2 x 0.5mm² twisted pair, shielded

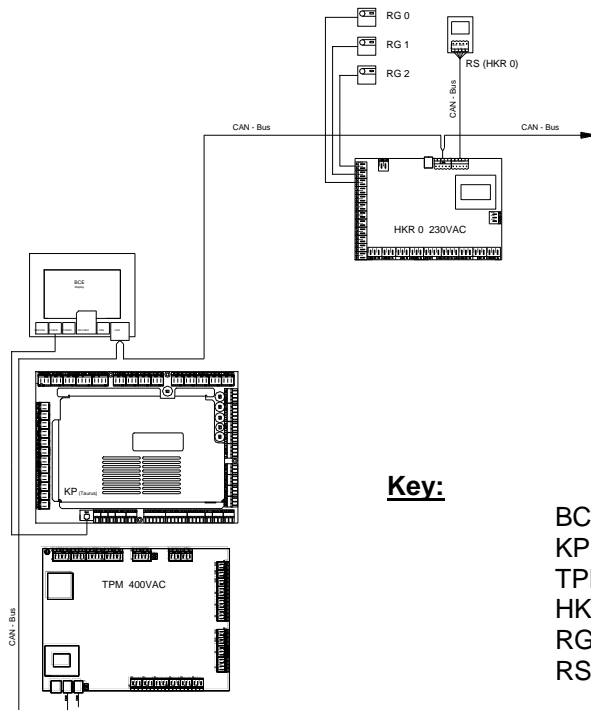

More outside-temp. based controllers can be connected via CAN bus

Key:

- BCE → Control panel
- KP → Boiler PCB
- TPM → Conveyor module
- HKR → Heating circuit controller
- RG → Analogue room stat
- RS → Digital room controller

Wiring CAN bus in line

Whenever possible, always wire the CAN bus "in line", i.e. from the display and control unit to heating circuit controller 0 then from there to heating circuit controller 1, and so on. If wired in a star pattern, the overall length of the CAN bus must not exceed 100 metres. Wire the CAN bus +/- and H/L connections with twisted-pair cable in each case.

4.3 Electrical connections

The electrical connections to the boiler system on site may only be made by an approved electrical installer observing all the applicable regulations. In addition, it is essential that electrical system components are protected against damage from heat radiation.

All boiler system internal wiring is wired up at the factory ready for use. The work required on site by the electrical installer consists only of connecting the mains power and wiring up and connecting the system components such as thermal store, CAN bus, heating circuit pumps, mixer valve motors, etc.

Mains connection 400V, 50Hz, 20A (surge protector recommended)

The mains power must be connected by means of the standard non-reversible power socket on the rear panel of the boiler. It must be possible to isolate the system entirely from the mains – either by means of the master switch outside the boiler room door, an automatic circuit-breaker in the control cabinet or the power plug on the rear of the boiler – without opening the switch panel cover.

Pay attention to correct connection of phases!

Master switch (heating system)

The heating system must be capable of being fully isolated from the mains power supply by means of a master switch mounted outside the boiler room door which can be secured in the 0/OFF position by locking and removing the key so as to prevent it being switched on by unauthorised persons.

Emergency off switch (heating system)

According to prTRVB H 118, it must be possible to switch off the system using an emergency off switch fitted outside the boiler room door. The burner must then shut down but the heating controller and all safety equipment must remain functional. Connected to the boiler enabling switch, terminals 22/23, on the boiler circuit board.

Safety switch (storeroom)

The agitator must be capable of being switched off by means of a safety switch mounted outside the boiler room door which can be secured in the 0/OFF position by locking and removing the key so as to prevent it being switched on by unauthorised persons.

Opening switch panel

Before the switch panel is opened, the boiler must be completely isolated from the power supply. **The system must not be live.**



Caution: If the boiler is only switched off at the power switch, numerous components remain connected to the power supply.

The switch panel must not be opened in those circumstances.

- Release the switch panel catch and lift open the controller cover panel and secure it.
- The circuit boards with the associated connectors and fuses (see electrical wiring diagram) are located underneath it in an easily accessible position.
- The appropriate cable ducts must be used when connecting electrical leads.

Network system controller The outside-temperature based network system controller is integrated in the boiler circuit board of the system. To prevent overload by powerful pumps or mixer valves, all outputs used must be connected via coupling relays.

Outside-temperature based controller The MK-261 wall controller set outside-temperature based heating circuit controller is mounted on a wall and connected to the boiler control panel via a CAN bus. To prevent overload by powerful pumps or mixer valves, all outputs used must be connected via coupling relays. Operation and configuration of the controller is via the control panel on the boiler.

MK261 wall controller set (max. 3 MK261 wall controller sets per boiler possible)

With an MK261 wall controller set it is possible to control one DHW cylinder, one pumped heating circuit and 2 mixer-valve heating circuits. Selecting the Supplementary option allows heat to be requested from a 2nd DHW cylinder or a peak load boiler per wall controller using the cascade function. The option District heating mode allows the district heating functions CP or TSP to be selected.

Note If the Supplementary and District heating functions are not used on the wall controller, Heating circuit 0 can be used in each case as a third mixer-valve heating circuit connected to the wall controller.

Connect the MK261 wall controller set to the power supply at terminal H35 and to the control panel via the CAN bus.

Analogue room stat Each room stat should be connected internally at terminals 1 and 2 and to the relevant input on the heating circuit controller.

Digital room controller The room controller must be connected via CAN bus to the boiler control panel or the MK261 wall controller set.

3rd mixer-valve heating circuit Heating circuit 0 can only be used as a mixer-valve heating circuit if the Supplementary and District heating functions are not activated on the wall controller. The mixer valve must be connected to terminals H25 and H26 and the heating circuit pump to terminal H33 on the wall controller.

2nd DHW cylinder **Can be activated on the boiler or on the MKR261 wall controller set.**
With the network system controller on the boiler, the function Supplementary (WWP) can be used to connect the 2nd cylinder charging pump to terminal H33 and the 2nd cylinder sensor (ZSF) to terminals H15/H16.

On the MK261 wall controller set the Supplementary 0, 1 or 2 (WWP) function can be used to connect the 2nd cylinder charging pump to terminal H25 and the 2nd cylinder sensor (ZSF) to terminals H15/H16.

Peak load boiler **Can be activated on the boiler or on the MKR261 wall controller set.**
With the network system controller on the boiler, the Supplementary (EXTERNAL) function can be used to connect a peak load boiler to terminal H33.

On the MK261 wall controller set the Supplementary 0, 1 or 2 (EXTERNAL) function can be used to connect a peak load boiler to terminal H25.

Network system pumps Connection of network system pumps (NKP0-NKP2).
NKP 0 = Terminal H33 / NKP 1 = Terminal H28 / NKP 2 = Terminal H27

Network system pumps with mixer valves Connect the network system pumps (NKP1a/b-NKP2a/b) to the following terminals:

NKP 1a = Terminal H28 / NKP 1b = Terminal H33
NKP 2a = Terminal H27 / NKP 2b = Terminal H34

Connect the mixer valves (MI1-MI2) to the following terminals:

MI 1 = Terminal H31-H32 / MI 2 = Terminal H29-H30

Connect the return temperature sensors (RF1 and RF2) to the following terminals:

RF 1 = Terminal H15-H16 / RF 2 = Terminal H13-H14

Boiler cascade Up to four heating boilers can be operated in a cascade system (sequential control system) and must be connected in-line via a CAN bus. **The CAN bus lead must be wired without connecting the + terminal.**



Pay special attention to the section "Wiring requirements, Wiring CAN bus in line".

2-sensor thermal store management **Can be activated on the boiler circuit board.**

On the boiler circuit board the thermal store lower sensor (T2) must be connected to terminals 31/32 and the thermal store upper sensor (T3) to terminals 33/34.

On the wall controller the thermal store lower sensor (T2) must be connected to terminals H17/H18 and the thermal store upper sensor (T3) to terminals H19/H20.

5-sensor thermal store management **Can be activated on the boiler circuit board.**

Three additional thermal store sensors can be connected to terminals H1/H2 (T5), H3/H4 (T6) and H5/H6 (T7).

Note If those inputs are used for 5-sensor thermal store management, the heating circuits can continue to be used without room thermostats.

Note 5-sensor thermal store management is only usable for thermal store HP0.

Surge protection We recommend the installation of a power surge protector in the building's consumer unit.



Pay special attention to the section "Wiring requirements, Surge protection".

Earthing The entire system is to be joined to the earth circuit conductor via the connected piping system according to the regulations.



When connecting the earth circuit conductor pay particular attention to keeping the connecting runs as short as possible.

Emergency power supply Only use regulated generators.

5 Final checks/Commissioning

BS-04-00-00-01-IADE

Final checks

- After completing installation of the system, check again that all joints and pipes are properly tightened and not leaking.
- Check that all covers are fitted and secured.
- Check that the fitting of all connections (water, flue, electrical, ...) has been done correctly.
- Check that all required safety signs and instructions are attached and hand over all documentation (operating and installation instructions) for the system.
- Check that all electrical connections have been properly wired before connecting the system to the power supply.
- Clean the system and clear up the installation site.
- Always leave the boiler room clean.

Initial commissioning

Commissioning must only be carried out by GUNTAMATIC or a qualified specialist. The precondition is that the flue technician, heating installer and electrician have cleared the system for operation. The authorised GUNTAMATIC specialist will carry out the following work during commissioning:

- Check the entire system
- Check the electrical functions
- Adjust the programmer to the system
- Commission the system
- Explain to the user how the system functions and how to operate and clean it
- Record the details of the customer and the system and complete the commissioning log

**Important** →

Any deficiencies identified must be recorded in writing and rectified within the following 4 weeks in order to maintain guarantee entitlement.

The fully completed commissioning check-list must be sent to GUNTAMATIC immediately as otherwise the guarantee will be void.

**Important** →

These installation instructions should not be destroyed after commissioning but kept permanently with the system together with the operating instructions.

6 Standards/Regulations

BS-05-00-00-00-02-IADE

The heating appliance is designed in accordance with Class 3 to EN 303-5 and the agreement of the Austrian Federal States according to Art. 15a BVG relating to safety measures for small combustion heating systems and energy saving. The original type approval certificates are available for inspection at the manufacturer's offices. When connecting the boiler, the following generally applicable standards and safety regulations must be followed in addition to the local fire safety and building control requirements:

- **ÖNORM/DIN EN 303-5**
Boilers for solid fuels, manually and automatically stoked, with outputs up to 300 kW;
Terms, requirements, tests and identification;
- **ÖNORM/DIN EN 12828**
Heating systems inside buildings; planning hot-water circulation heating systems
- **ÖNORM/DIN EN 12831**
Heating systems inside buildings; procedures for calculating rated heat input;
- **ÖNORM M 7137**
Requirements for pellet storage by the end user;
- **ÖNORM M 7510**
Guidelines for the inspection of central heating systems
- **ÖNORM H 5195-1** (Austria)
Preventing damage from corrosion and scale formation in hot-water circulation heating systems with operating temperatures up to 100°C;
- **VDI 2035** (Germany)
Preventing damage in hot-water circulation heating systems; corrosion from heating-system water;
- **SWKI 97-1** (Switzerland)
Limescale and corrosion-proofing in heating systems;
- **TRVB H 118** (for automatically stoked systems in Austria)
Technical directive on preventative fire safety;
- **DIN 1988**
Technical regulations for household-water installations (TRWI);
- **DIN 4751 Part 1-4**
Safety systems for heating systems;
- Swiss Clean Air Regulations (LRV)
- Swiss Regulations on Small Combustion Heating Systems
- VKF Fire Safety Directive for Heating Systems (Switzerland)
- SIA 384 (Switzerland)

PRO175/250
for on-site heating circuit control

minimum thermal store capacity 4,000 litres

Tel. 07276 / 2441-0

office@guntamatic.com

www.guntamatic.com

GUNTAMATIC

Diagram no. PRO-01-01

Electrical connections as per operating and installation instructions

Note:

If network system controller is used, heating system controller cannot be activated.

- | | |
|--|-------------------|
| 1. PRO 175/250 (1 module) | As price list |
| 2. Flue draught regulator RE (size to suit flue diameter) | As price list |
| 3. Return boost set | |
| Pump HP0 - 230V (e.g. Wilo-Stratos 50/1-12) | Not supplied |
| Mixer valve - 2" (DN50), Kvs>=60 (e.g. ESBE) | Not supplied |
| 4. Thermal store Akkutherm 2000/2PS | As price list |
| 5. GSM module | Art. no.: S15-002 |
| 6. Fault indicator lamp Important: follow wiring diagram! | Not supplied |
| 7. Pipe size 2" | Not supplied |
| 8. If pipe length exceeds 2 x 25m for thermal store flow and return, use 3" pipe | Not supplied |
| 9. Order 5 thermal store sensors | Art. no.: S70-003 |
| 10. T-joints, minimum size 4" | Not supplied |
| 11. For network system control order outside temp. sensor | Art. no.: S70-001 |

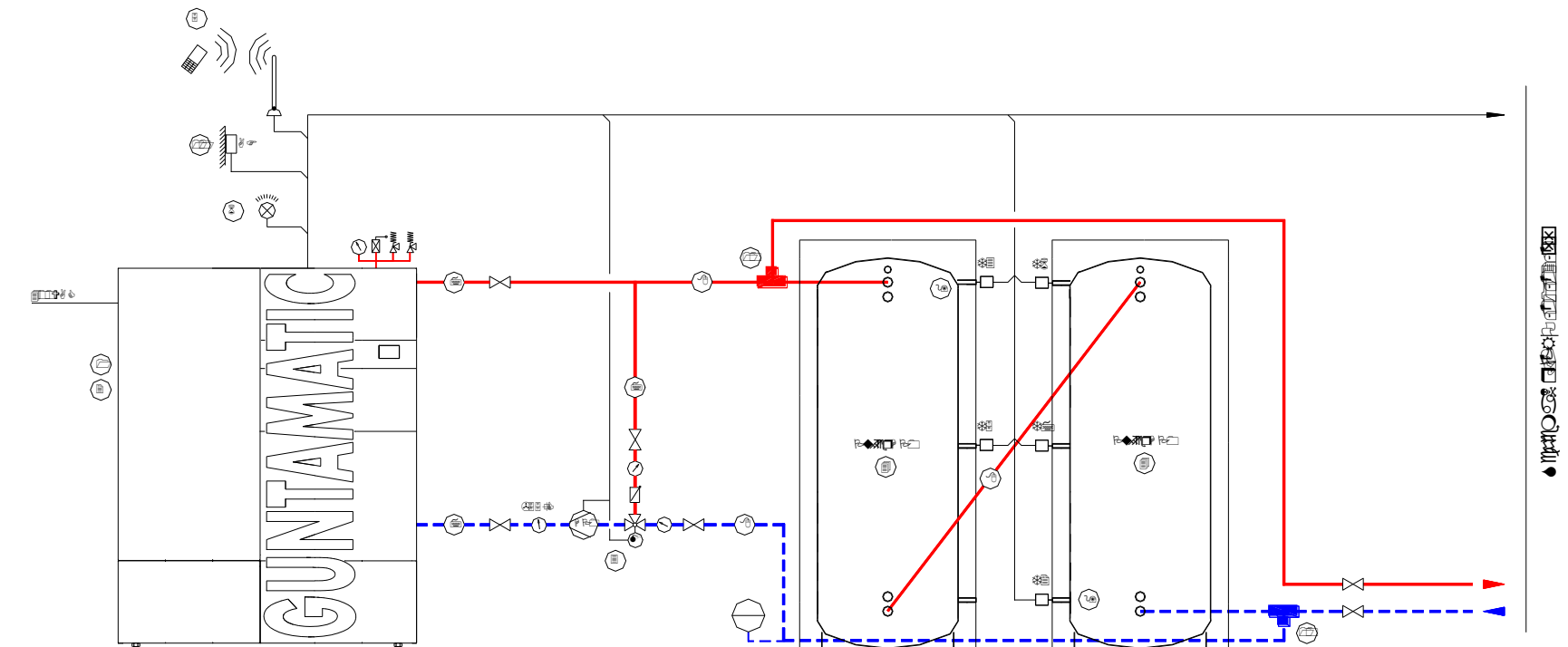

PRO 350/425/500
for on-site heating circuit control

minimum thermal store capacity 10,000 litres

Tel. 07276 / 2441-0

office@guntamatic.com

www.guntamatic.com

GUNTAMATIC

Diagram no. PRO-01-02

Electrical connections as per operating and installation instructions

Note:

If network system controller is used, heating system controller cannot be activated.

1. PRO 350/425/500 (2 modules) As price list
2. Flue draught regulator RE (size to suit flue diameter) As price list
3. Return boost set
Pump HP0 - 230V (e.g. Wilo-Stratos 50/1-12) Not supplied
Mixer valve - 2" (DN50), Kvs>=60 (e.g. ESBE) Not supplied
4. Thermal store min. capacity 10,000 litres Not supplied
5. GSM module Art. no.: S15-002
6. Fault indicator lamp **Important: follow wiring diagram!** Not supplied
7. Pipe size 2" Not supplied
8. If pipe length exceeds 2 x 25m for thermal store flow and return, use 3" pipe Not supplied
9. Order 5 thermal store sensors per module Art. no.: S70-003
10. For network system control order outside temp. sensor Art. no.: S70-001
11. **Note:** Make sure the distribution piping in the area of the flow and return connections is adequately dimensioned.

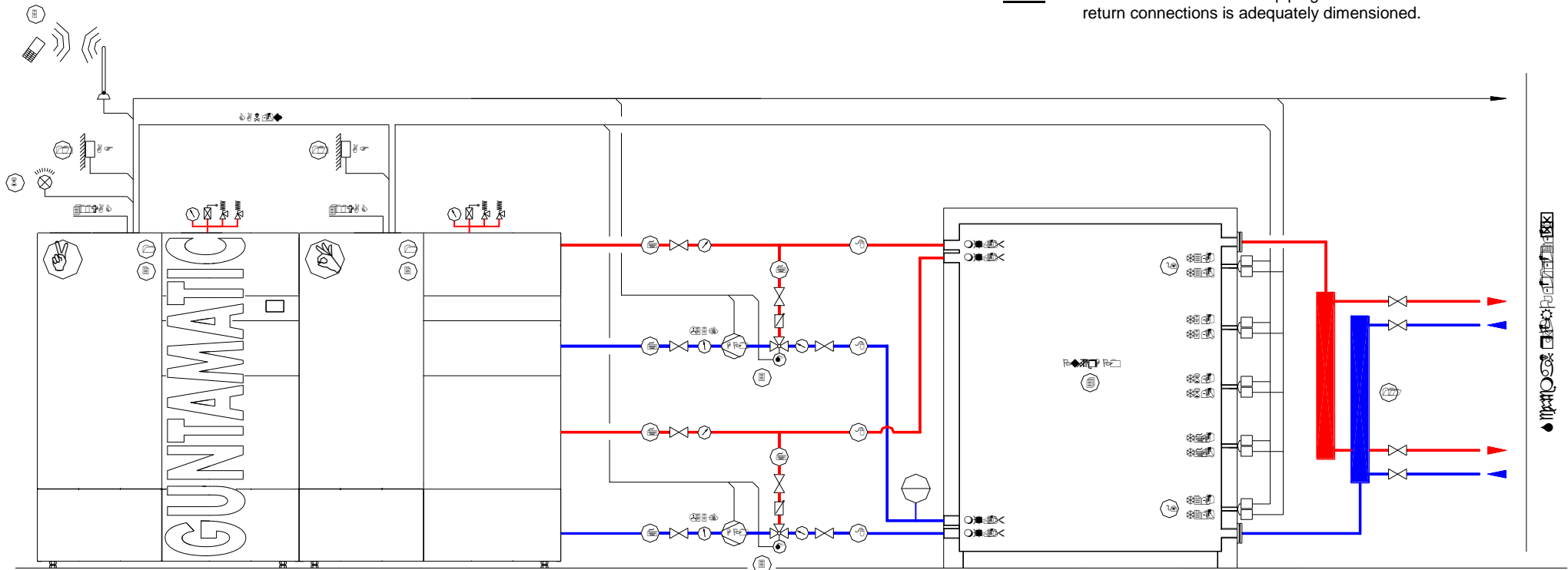

HP0 setting = Thermal store pump

Heat from biomass 35

PRO
Function of network system pump
max. 3 network system pumps possible

Tel. 07276 / 2441-0

office@guntamatic.com

www.guntamatic.com

GUNTAMATIC

Diagram no. PRO-01-02-01

Electrical connections as per operating and installation instructions

1. Network system pumps 0-2
2. Order outside temp. sensor

Not supplied
Art. no.: S70-001

Information:

- Each network system pump can be timer-controlled by its own timer programme and also controlled on the basis of outside temperature by means of the functions Night OFF OT and OT Off.
- Network system 1 and Network system 2 can also be operated by means of mixer valves.
- A DHW cylinder can be charged.
- If Network system 0 is not used, the Supplementary function can be used to control a 2nd DHW cylinder or a peak load boiler.
- 0-10 volt input for network system pumps ON/OFF

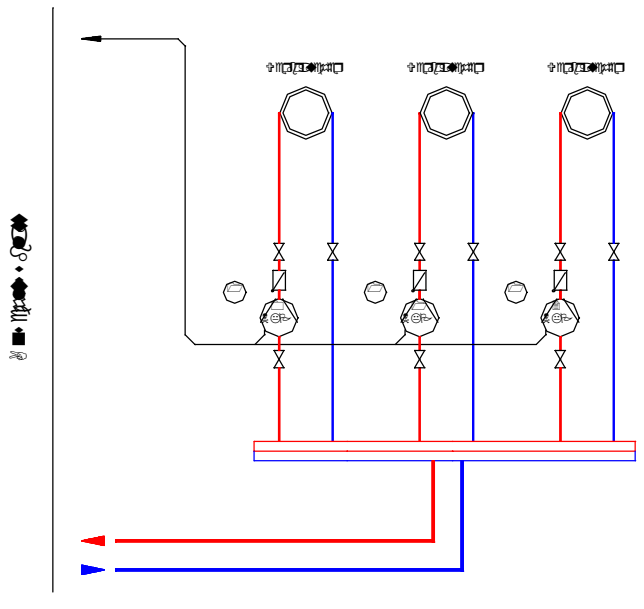

Note:

The network system pumps can be switched ON/OFF via a 0-10 volt input.

PRO
Function of network system pump with mixer valve
 max. 4 network system pumps and 2 mixer valves possible

Tel. 07276 / 2441-0

office@guntamatic.com

www.guntamatic.com

GUNTAMATIC

Diagram no. PRO-01-02-02

Electrical connections as per operating and installation instructions

1. Network system pumps 1a/1b and 2a/2b
2. Mixer valves 1-2
3. 2 sensors per network system required
4. Order outside temp. sensor

Not supplied
 Not supplied
 Art. no.: S70-002
 Art. no.: S70-001

Information:

- Each network system can be timer-controlled by its own timer programme and also controlled on the basis of outside temperature by means of the functions Night OFF OT and OT Off.
- Each network system can be assigned a second network pump which can be automatically activated to boost the delivery rate according to the spread between network flow and return temperatures.
- If Network system 1 is operated with only 1 network system pump, the Supplementary function can be used to control a DHW cylinder (HWP) or a peak load boiler (EXTERNAL).
- 0-10 volt input for network system ON/OFF

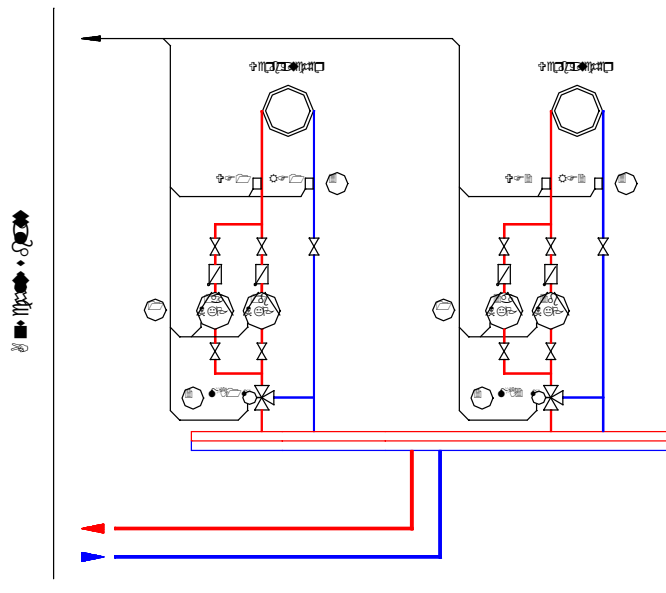

Note:

The network systems can be switched ON/OFF via a 0-10 volt input.

PRO 175/250
with heating circuit controller – no district heating
 max. 9 mixer-valve circuits and 3 DHW cylinders

minimum thermal store capacity 4,000 litres

Tel. 07276 / 2441-0

office@guntamatic.com

www.guntamatic.com

GUNTAMATIC

Diagram no. PRO-01-03

Electrical connections as per operating and installation instructions

- | | | |
|-----|---|-------------------|
| 1. | 175/250 (1 module) | As price list |
| 2. | Flue draught regulator RE (size to suit flue diameter) | As price list |
| 3. | Return boost set | |
| | Pump HP0 - 230V (e.g. Wilo-Stratos 50/1-12) | Not supplied |
| | Mixer valve - 2" (DN50), Kvs>=60 (e.g. ESBE) | Not supplied |
| 4. | Thermal store Akkutherm 2000/2PS | As price list |
| 5. | GSM module | Art. no.: S15-002 |
| 6. | Fault indicator lamp Important: follow wiring diagram! | Not supplied |
| 7. | Pipe size 2" | Not supplied |
| 8. | If pipe length exceeds 2 x 25m for thermal store flow and return, use 3" pipe | Not supplied |
| 9. | Order 5 thermal store sensors | Art. no.: S70-003 |
| 10. | T-joints, minimum size 4" | Not supplied |

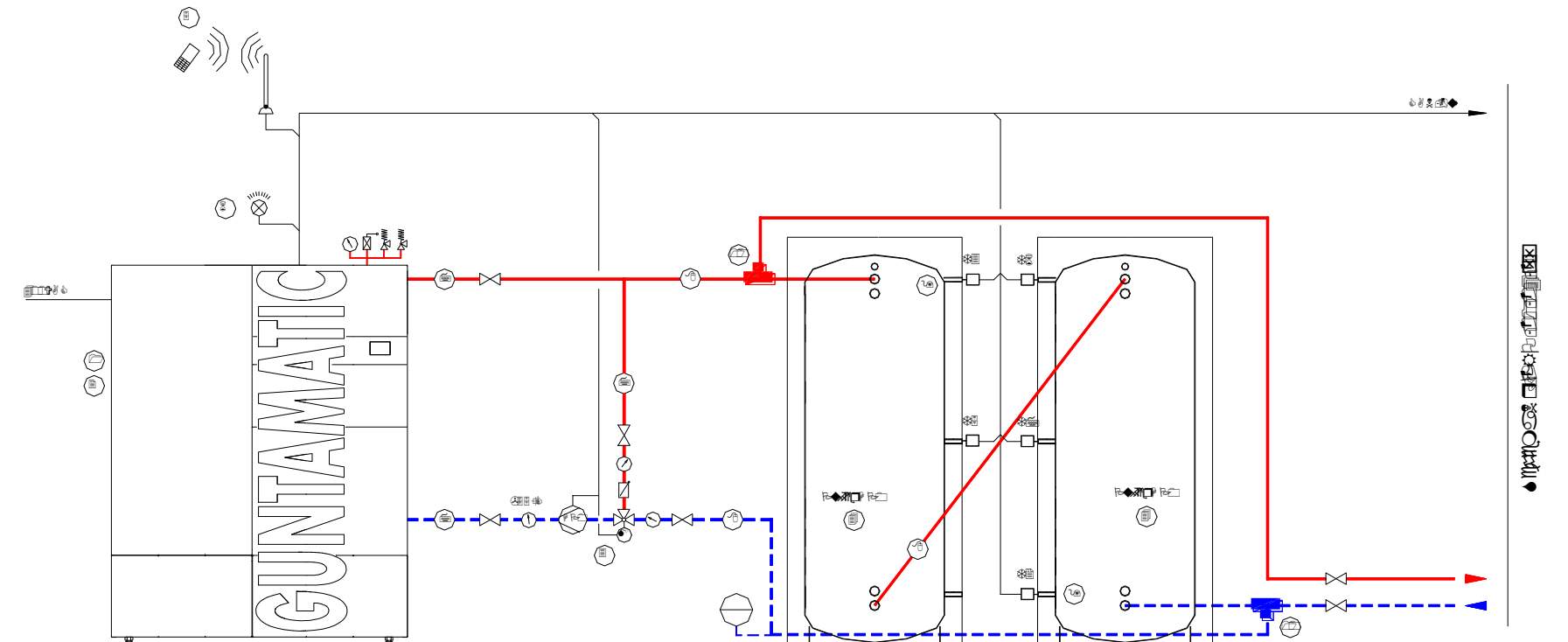

PRO 350/425/500
with heating circuit controller – no district heating
 max. 18 mixer-valve circuits and 6 DHW cylinders

minimum thermal store capacity 4,000 litres

Tel. 07276 / 2441-0

office@guntamatic.com

www.guntamatic.com

GUNTAMATIC

Diagram no. PRO-01-04

Electrical connections as per operating and installation instructions

- | | |
|--|-------------------|
| 1. PRO 350/425/500 (2 modules) | As price list |
| 2. Flue draught regulator RE (size to suit flue diameter) | As price list |
| 3. Return boost set | |
| Pump HP0 - 230V (e.g. Wilo-Stratos 50/1-12) | Not supplied |
| Mixer valve - 2" (DN50), Kvs>=60 (e.g. ESBE) | Not supplied |
| 4. Thermal store AK2000/2PS | As price list |
| 5. GSM module | Art. no.: S15-002 |
| 6. Fault indicator lamp Important: follow wiring diagram! | Not supplied |
| 7. Pipe size 2" | Not supplied |
| 8. If pipe length exceeds 2 x 25m for thermal store flow and return, use 3" pipe | Not supplied |
| 9. Order 2 special flanges, DN80 (3"), per thermal store | As price list |
| 10. Order 5 thermal store sensors per module | Art. no.: S70-003 |
| 11. Note: Make sure the distribution piping in the area of the flow and return connections is adequately dimensioned. | |

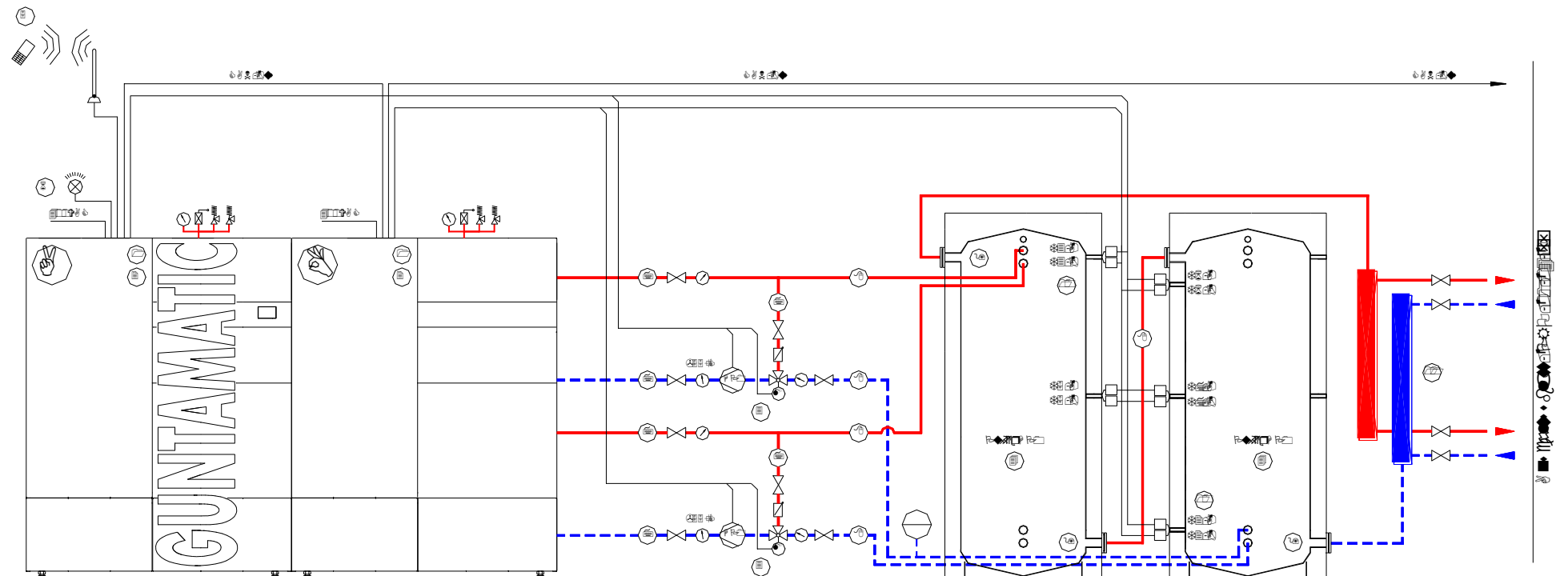

HP0 setting = Thermal store pump

Heat from biomass 39

PRO
Outside-temperature based controller
 max. 3 heating circuit controllers per boiler possible

Tel. 07276 / 2441-0

office@guntamatic.com

www.guntamatic.com

GUNTAMATIC

Diagram no. PRO-01-04-01

Electrical connections as per operating and installation instructions

- | | |
|--|-------------------|
| 1. Outside temp. based wall controller set MKR261 | Art. no.: S30-030 |
| Important: observe the maximum load capacity of the wall controller. | |
| 2. Analogue room stat | Art. no.: S70-006 |
| Digital room controller | Art. no.: S60-004 |
| 3. Mixer-valve motor | Art. no.: S50-501 |

Information:

- Always connect outside temp. sensor (AF) to HKR-0
- A maximum of 3 MK261 wall controller sets can be connected to each boiler (A, B, ...); the heating circuit controllers are then designated HKR-A0, HKR-B1, etc., for example.
- One analogue room stat (RFF) can be connected to each heating circuit.
- A maximum of 3 digital room controllers (RS) can be connected to each boiler.

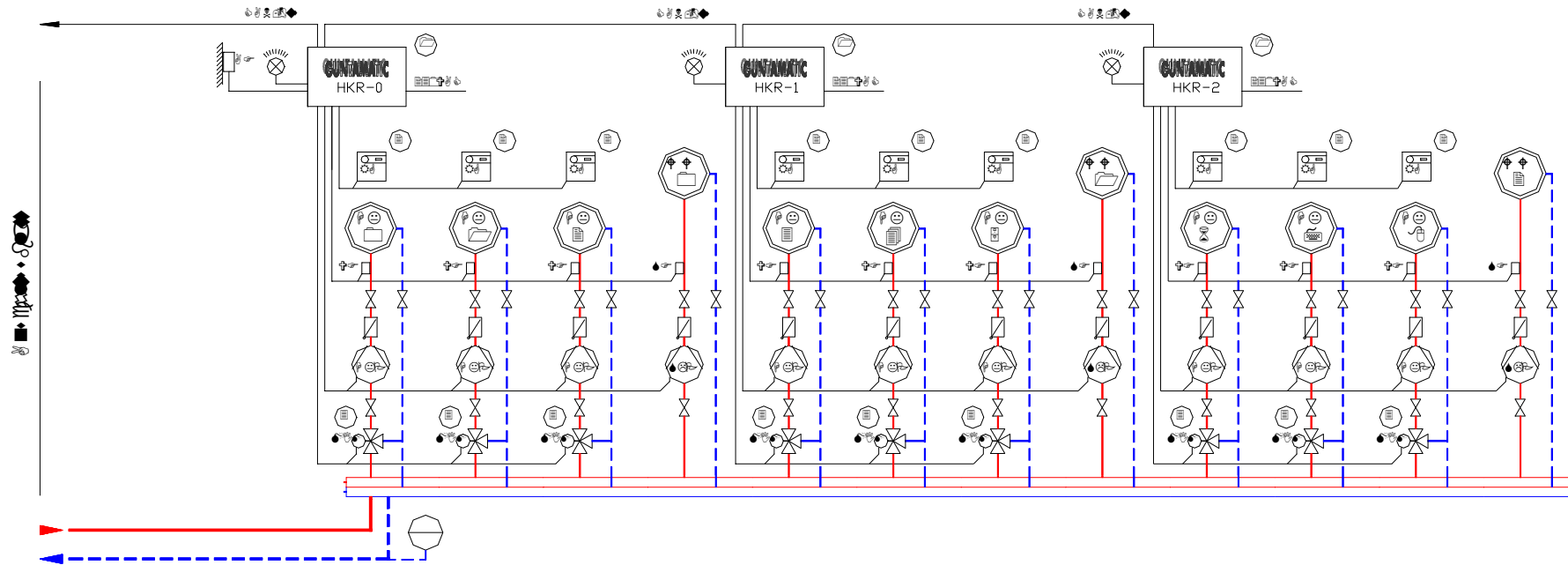

PRO 175/250**Building supply using heating circuit controller and district heating**

max. 3 buildings – max. 3 heating circuit controllers per boiler possible

minimum thermal store capacity 4,000 litres

Tel. 07276 / 2441-0

office@guntamatic.com

www.guntamatic.com

GUNTAMATIC**Diagram no. PRO-01-05**

Electrical connections as per operating and installation instructions

1. PRO 175/250 (1 module) As price list
2. Flue draught regulator RE (size to suit flue diameter) As price list
3. Return boost set
Pump HP0 - 230V (e.g. Wilo-Stratos 50/1-12) Not supplied
Mixer valve - 2" (DN50), Kvs>=60 (e.g. ESBE) Not supplied
4. Thermal store AK2000/2PS As price list
5. GSM module Art. no.: S15-002
6. Fault indicator lamp **Important: follow wiring diagram!** Not supplied
7. Pipe size 2" Not supplied
8. If pipe length exceeds 2 x 25m for thermal store flow and return, use 3" pipe Not supplied
9. Order 2 special flanges, DN80 (3"), per thermal store As price list
10. Order 5 thermal store sensors per module Art. no.: S70-003
11. **Important:** always wire the CAN bus "in line"; if wired in a star pattern, the maximum cable length is 100 m
12. T-joints, minimum size 4"
13. **Note:** Make sure the distribution piping in the area of the flow and return connections is adequately dimensioned.

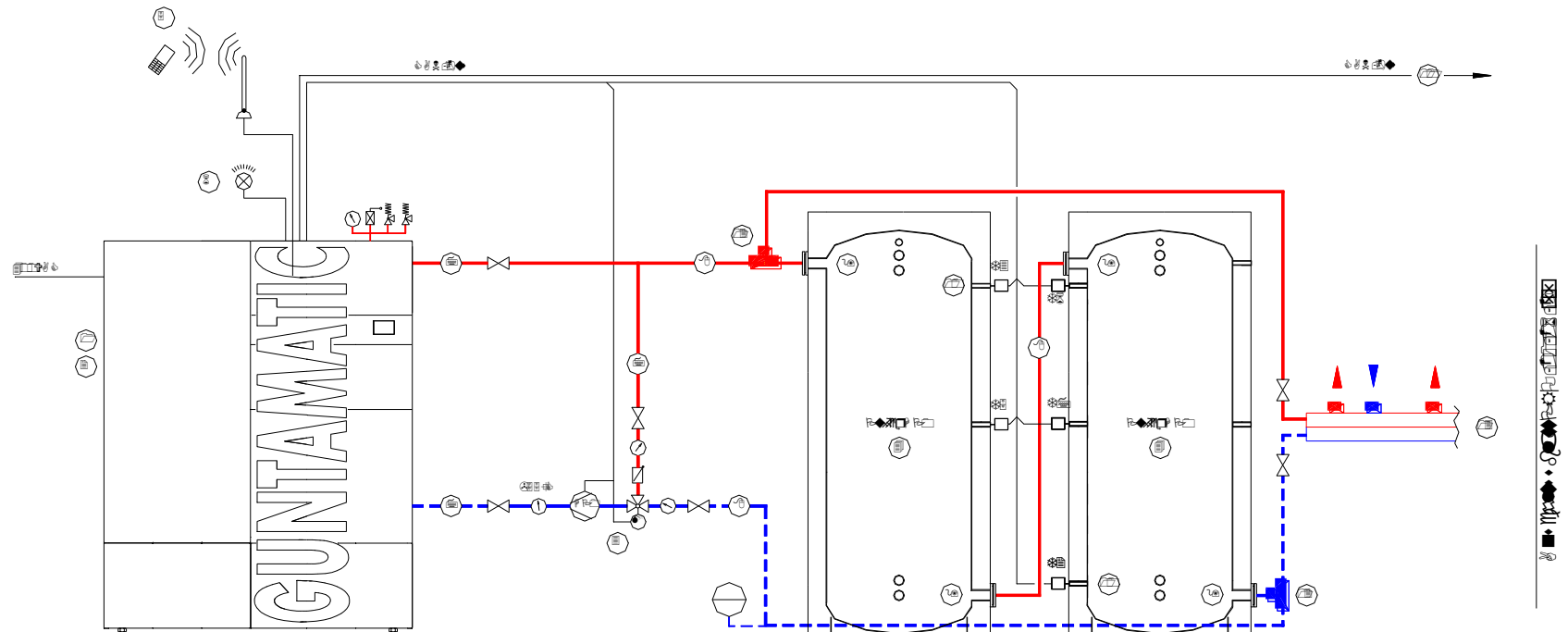

PRO 350/425/500**Building supply using heating circuit controller and district heating**

max. 6 buildings – max. 3 heating circuit controllers per boiler possible

minimum thermal store capacity 4,000 litres

Tel. 07276 / 2441-0

office@guntamatic.com

www.guntamatic.com

GUNTAMATIC**Diagram no. PRO-01-06**

Electrical connections as per operating and installation instructions

1. PRO 350/425/500 (2 modules) As price list
2. Flue draught regulator RE (size to suit flue diameter) As price list
3. Return boost set
Pump HP0 - 230V (e.g. Wilo-Stratos 50/1-12) Not supplied
Mixer valve - 2" (DN50), Kvs>=60 (e.g. ESBE) Not supplied
4. Thermal store AK2000/2PS As price list
5. GSM module Art. no.: S15-002
6. Fault indicator lamp **Important: follow wiring diagram!** Not supplied
7. Pipe size 2" Not supplied
8. If pipe length exceeds 2 x 25m for thermal store flow and return, use 3" pipe Not supplied
9. Order 2 special flanges, DN80 (3"), per thermal store As price list
10. **Important:** always wire the CAN bus "in line"; if wired in a star pattern, the maximum cable length is 100 m
11. Order 5 sensors per module Art. no.: 70-003
12. **Note:** Make sure the distribution piping in the area of the flow and return connections is adequately dimensioned.

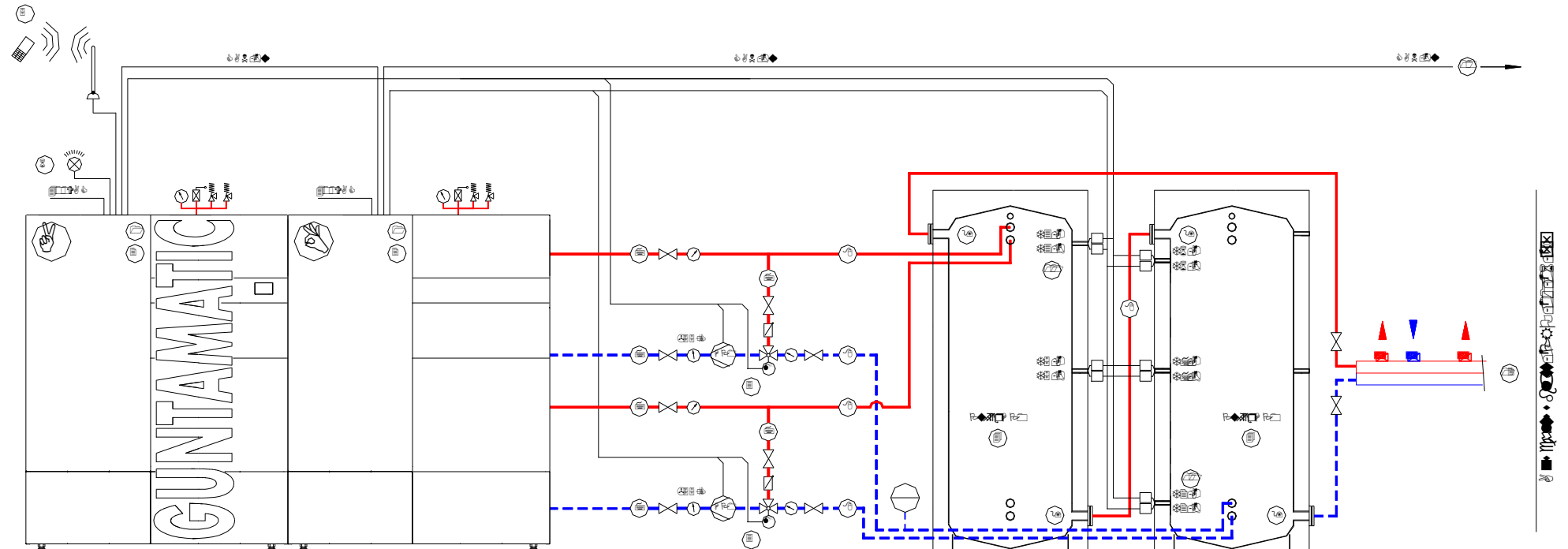

HP0 setting = Thermal store pump

Heat from biomass 42

PRO
Building supply using heating circuit controller and district heating function FP
 max. 3 heating circuit controllers per boiler possible

Tel. 07276 / 2441-0

office@guntamatic.com

www.guntamatic.com

GUNTAMATIC

Diagram no. PRO-01-06-01

Electrical connections as per operating and installation instructions

Information:

- Always connect outside temp. sensor (AF) to HKR-0 – configure HKR-1 and HKR-2 without outside temp. sensor; in the case of multiple boilers, an outside temp. sensor must be connected to each of HKR-A0, HKR-B0, etc.
- Each heating circuit controller with district heating function activated can be extended by two additional heating circuit controllers using the function ERW (max. 3 heating circuit controllers per boiler).

- | | |
|--|-------------------|
| 1. Outside temp. based wall controller set MKR261 | Art. no.: S30-030 |
| Important: observe the maximum load capacity of the wall controller. | |
| 2. Analogue room stat | Art. no.: S70-006 |
| Digital room controller | Art. no.: S60-004 |
| 3. Mixer-valve motor | Art. no.: S50-501 |
| 4. District heating pipe and dimensioning | Not supplied |
| 5. Pump and dimensioning | Not supplied |
| Important: observe the maximum load capacity of the output. | |
| 6. Flow equaliser and dimensioning | Not supplied |

Important:

- If the district heating function (FP, CP, ...) is used on a heating circuit controller, heating circuit 0 can only be operated as a pumped circuit without mixer valve.
- Heating circuit 0 can be used with a fixed-setting controller for a low-temperature heating system or can be room-temperature controlled using a room stat for a radiator heating system.

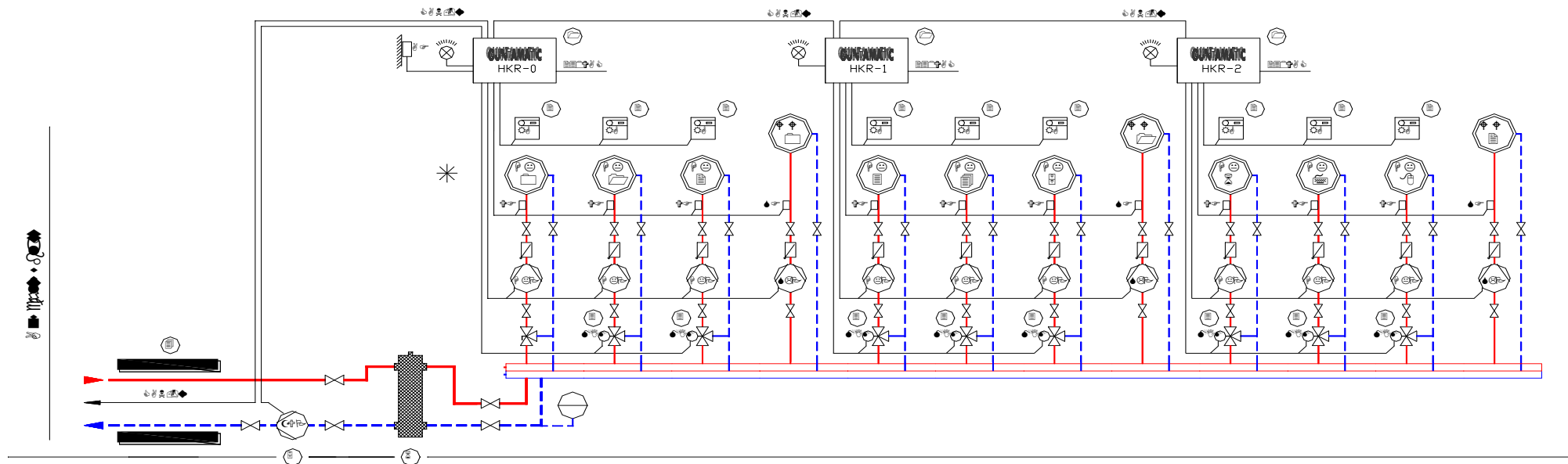

PRO
Building supply using heating circuit controller and district heating function FP
 max. 3 heating circuit controllers per boiler possible

Tel. 07276 / 2441-0

office@guntamatic.com

www.guntamatic.com

GUNTAMATIC

Diagram no. PRO-01-06-02

Electrical connections as per operating and installation instructions

Information:

- Always connect outside temp. sensor (AF) to HKR-0 – configure HKR-1 and HKR-2 without outside temp. sensor; in the case of multiple boilers, an outside temp. sensor must be connected to each of HKR-A0, HKR-B0, etc.

Important:

- If the district heating function (FP, CP, ...) is used on a heating circuit controller, heating circuit 0 can only be operated as a pumped circuit without mixer valve.
- Heating circuit 0 can be used with a fixed-setting controller for a low-temperature heating system or can be room-temperature controlled using a room stat for a radiator heating system.

- | | |
|--|-------------------|
| 1. Outside temp. based wall controller set MKR261 | Art. no.: S30-030 |
| Important: observe the maximum load capacity of the wall controller. | |
| 2. Analogue room stat | Art. no.: S70-006 |
| Digital room controller | Art. no.: S60-004 |
| 3. Mixer-valve motor | Art. no.: S50-501 |
| 4. DHW cylinder ECO | As price list |
| 5. District heating pipe and dimensioning | Not supplied |
| 6. Pump and dimensioning | Not supplied |
| Important: observe the maximum load capacity of the output. | |
| 7. Flow equaliser and dimensioning | Not supplied |

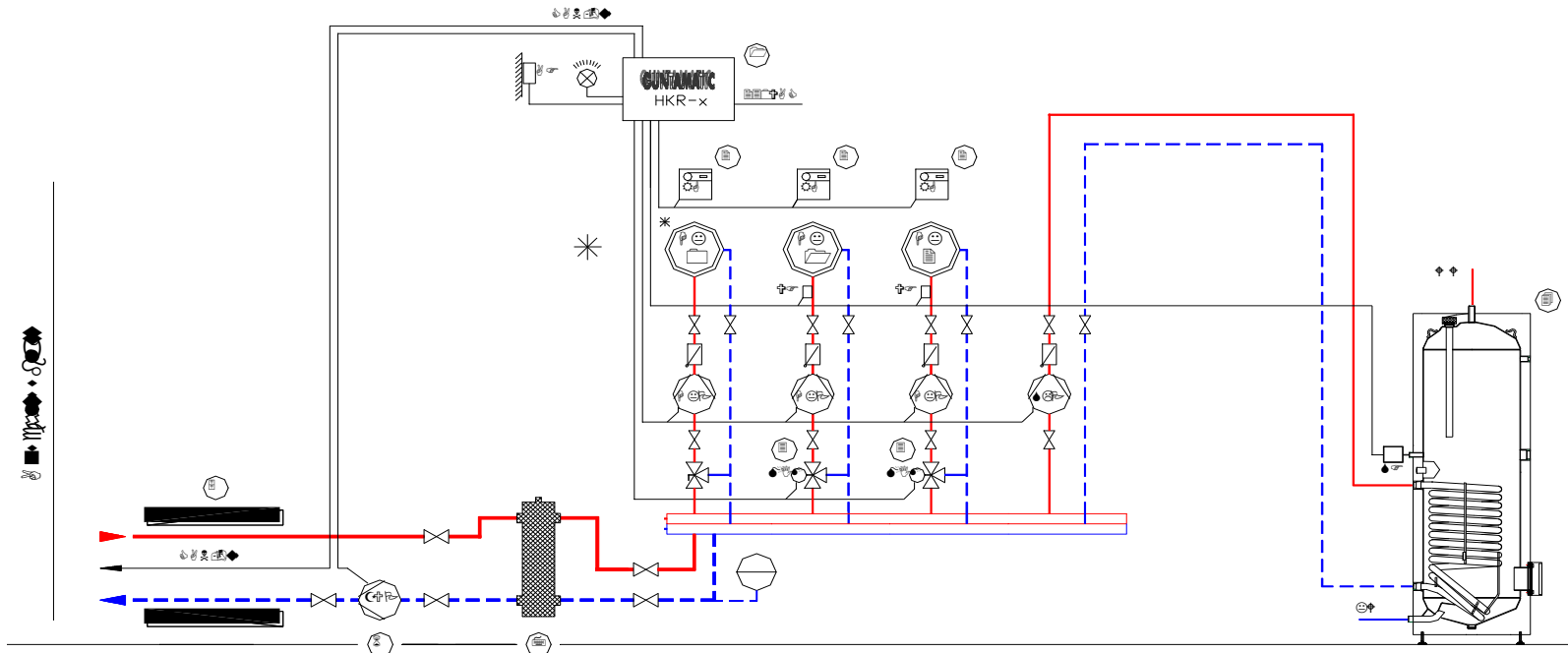

PRO
Building supply using heating circuit controller and district heating function CP
 max. 3 heating circuit controllers per boiler possible

Tel. 07276 / 2441-0

office@guntamatic.com

www.guntamatic.com

GUNTAMATIC

Diagram no. PRO-01-06-03

Electrical connections as per operating and installation instructions

Information:

- Always connect outside temp. sensor (AF) to HKR-0 – configure HKR-1 and HKR-2 without outside temp. sensor; in the case of multiple boilers, an outside temp. sensor must be connected to each of HKR-A0, HKR-B0, etc.

Important:

- If the district heating function (FP, CP, ...) is used on a heating circuit controller, heating circuit 0 can only be operated as a pumped circuit without mixer valve.
- Heating circuit 0 can be used with a fixed-setting controller for a low-temperature heating system or can be room-temperature controlled using a room stat for a radiator heating system.

- Outside temp. based wall controller set MKR261 Art. no.: S30-030
Important: observe the maximum load capacity of the wall controller.
- Analogue room stat Art. no.: S70-006
Digital room controller Art. no.: S60-004
- Mixer-valve motor Art. no.: S50-501
- Thermal store PSF As price list
- Pump and dimensioning Not supplied
Important: observe the maximum load capacity of the output.
- Order 2 thermal store sensors Art. no.: S70-003
- Option:** Secondary return pump Art. no.: 045-250
- Option:** 12-hole flange and heat exchanger As price list
- District heating pipe and dimensioning Not supplied

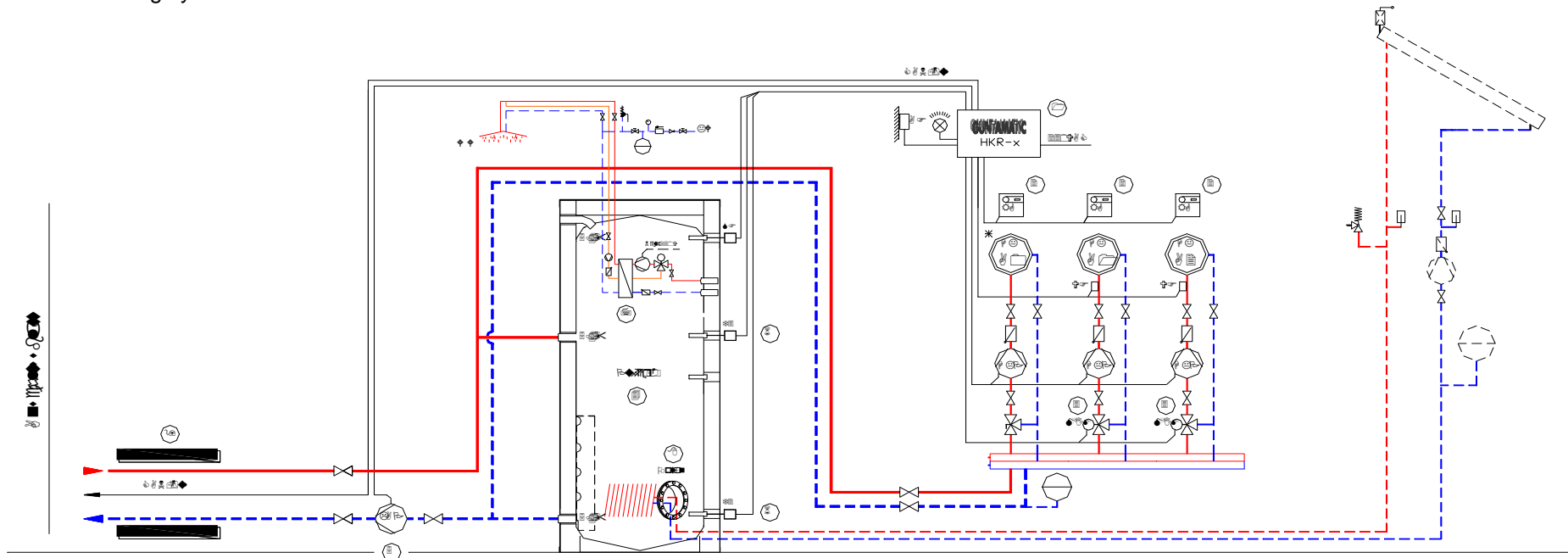

8 Technical data

PRO-Flex-08-00-00-00-01-IADE

8.1 PRO-Flex

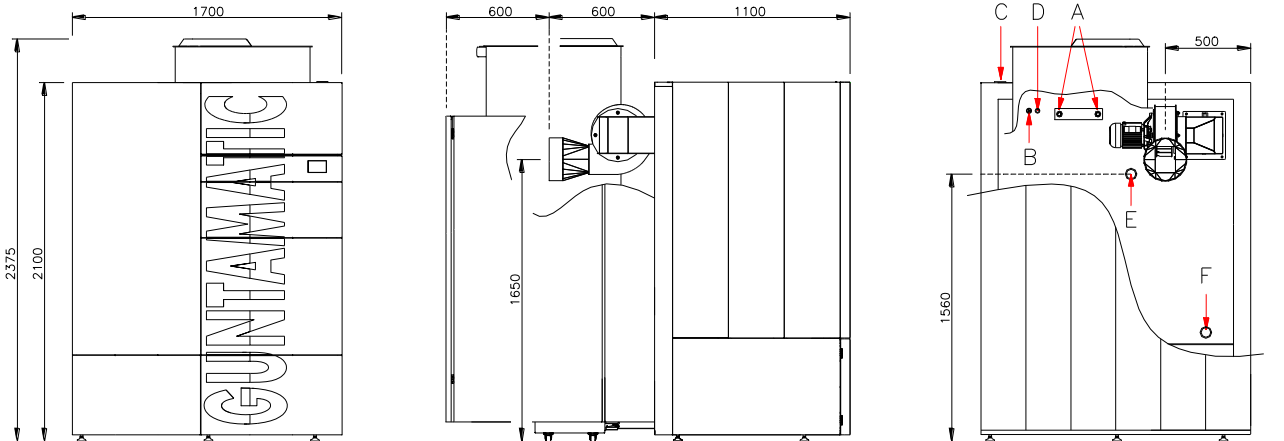

	Type PRO 175 Type PRO 250	Set PRO 350 Set PRO 425 Set PRO 500	Set PRO 600 Set PRO 750	Set PRO 850 Set PRO 1000	
PRO-Flex fuel	Wood pellets grade ENplus A1 and A2 (EN 14961-2)				
PRO 175 boiler output PRO 250 boiler output	188 199.5*/250**	Total output is combined output of the modules concerned			kW
Required flue draught	10	10	10	10	Pa
Boiler temperature	60 - 85	60 - 85	60 - 85	60 - 85	°C
Return temperature	55	55	55	55	°C
Water capacity (total)	600	1200	1800	2400	litres
Operating pressure	max. 3	max. 3	max. 3	max. 3	bar
PRO 175	Flow rate 8084	-	-	-	kg/h
Water system resistance	Temp. 16.9	-	-	-	°C
Temperature difference 20K	Diff. pressure 20.7	-	-	-	mbar
PRO 175	Flow rate 16168	-	-	-	kg/h
Water system resistance	Temp. 16.9	-	-	-	°C
Temperature difference 10K	Diff. pressure 80.3	-	-	-	mbar
PRO 250	Flow rate 10750	-	-	-	kg/h
Water system resistance	Temp. 18.3	-	-	-	°C
Temperature difference 20K	Diff. pressure 36.7	-	-	-	mbar
PRO 250	Flow rate 21500	-	-	-	kg/h
Water system resistance	Temp. 18.1	-	-	-	°C
Temperature difference 10K	Diff. pressure 142.6	-	-	-	mbar
Ash capacity	max. 240	max. 480	max. 720	max. 960	litres
Flue connecting pipe dia.	250	2 x 250	3 x 250	4 x 250	mm
A = Temp.-relief heat exch.	3/4"	-	-	-	Inches
B = Boiler sensor, STL	-	-	-	-	Inches
C = Flow	2"	-	-	-	Inches
D = Sensor for item A	1/2"	-	-	-	Inches
E = Return	2"	-	-	-	Inches
F = Drain	2"	-	-	-	Inches
Overall weight	Approx. 2200	Approx. 4400	Approx. 6600	Approx. 8800	kg
Weight of bottom box	Approx. 600	-	-	-	kg
Weight of heat exchanger	Approx. 1000	-	-	-	kg
Weight of stoker unit	Approx. 130	-	-	-	kg
Weight of drive unit	Approx. 70	-	-	-	kg
Weight per m of outfeed auger	Approx. 26	-	-	-	kg
Temperature-relief heat exchanger	Yes	Yes	Yes	Yes	
Power supply	400 V 20 A	400 V 20 A	400 V 20 A	400 V 20 A	

* Specified rated output for module output < 400 kW / ** maximum possible boiler output

8.2 FLEX fuel outfeed system

Bulk storage height:

Pellets → max. 2.5m

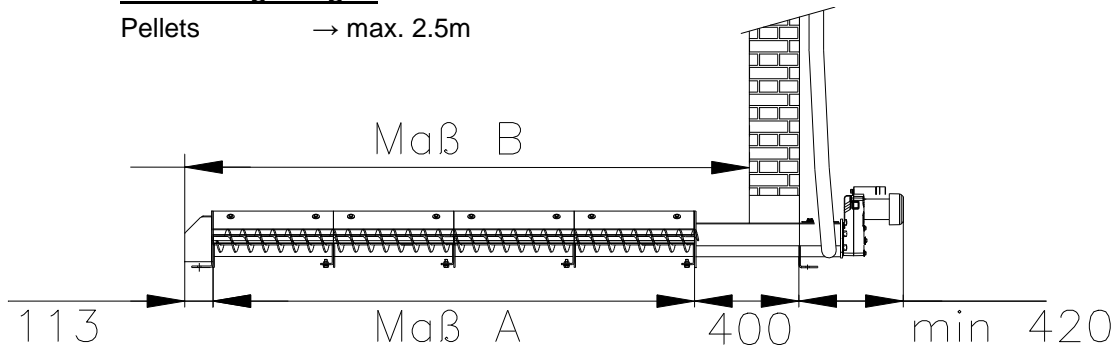

Dimension A > Auger length	Dimension B > Storeroom internal clear length
FLEX 3.0 m	3000mm – 3479mm
FLEX 3.5 m	3480mm – 3959mm
FLEX 4.0 m	3960mm – 4439mm
FLEX 4.5 m	4440mm – 4919mm
FLEX 5.0 m	4920mm - .

Wall opening for auger: Width 330mm
Height 250mm

GUNTAMATIC

GUNTAMATIC Heiztechnik GmbH

A – 4722 PEUERBACH Bruck 7

Tel: 0043 (0) 7276 / 2441-0

Fax: 0043 (0)7276 / 3031

E-mail: office@guntamatic.com

Subject to printing errors and technical amendments.