

MANUALS
USERS

Instruction booklet and
warning **IE**

 **IMMERGAS**

HYDRO FS

1.041956ENG



We would first of all like to thank you for having chosen one of our products.

We are sure you will be happy with it because it represents the state of the art in the technology of home air conditioning.

By following the suggestions contained in this manual, the product you have purchased will operate without problems, giving you optimum room temperatures with minimum energy costs.

Symbols

The pictograms in the next chapter provide the necessary information for correct, safe use of the appliance in a rapid, unmistakable way.

Safety pictograms

- | | |
|---|---|
|  Warning
The operation described may cause physical harm if not carried out in accordance with safety regulations. |  High temperature danger
Of safety regulations, the risk of burns caused by contact with components with high temperatures. |
|  Dangerous electrical current
Make personnel aware that the operation described may lead to electrical shocks if not carried out in accordance with safety regulations. |  Prohibition
Refers to prohibited actions. |







Summary

1. General.....	5	8.3 Identification	28
1.1 General warnings	5	8.4 Charts of Water flow - Pressure drop.....	29
2. Modulating temperature controller kit ..	6	8.5 Dimensions	30
2.1 Assembly, set-up and connection	6	8.6 Product delivery	31
2.2 Assembly.....	6	8.7 Handling and transportation	31
2.3 Set-up of auxiliary dip-switch functions B and C7		8.8 Access to inner parts.....	31
2.4 CP presence contact input connection.....	7	8.9 Installation	32
2.5 Air temperature probe assembly.....	8	8.10 Minimum installation distances	32
2.6 Connections	9	8.11 Vertically mounted	33
3. 4-speed temperature controller kit	10	8.12 Hydraulic connections	34
3.1 Assembly and connections.....	10	8.13 Condensation discharge.....	35
3.2 Assembly.....	10	8.14 Electrical connections.....	36
3.3 Air temperature probe assembly.....	11	8.15 Filling the system.....	36
3.4 Connections	11	8.16 Evacuation of air when filling system.....	37
3.5 Water probe kit management.....	11	8.17 First commissioning.....	37
4. Universal card kit for commercial temperature controller	12	9. Modulating temperature controller kit. 38	
4.1 Assembly and connections.....	12	9.1 SMART TOUCH electronic control panel.....	38
4.2 Assembly.....	12	9.2 Display	38
4.3 Connection diagram with 3-speed thermostat	13	9.3 Key function.....	38
4.4 Connections with 3-speed thermostats	13	9.4 General On Switch	39
4.5 LED signals.....	14	9.5 Activation	39
4.6 Water probe management with 3-speed thermostat	14	9.6 Heating/cooling operation modes setting.....	39
5. 0-10 V demand board kit	15	9.7 Stand By.....	39
5.1 Assembly and connections.....	15	9.8 Temperature selection	40
5.2 Assembly.....	15	9.9 Automatic operation	40
5.3 LED signals.....	15	9.10 Silent operation	40
5.4 Connection diagram with 0-10V DC thermostats / signals	16	9.11 Night-time operation	40
5.5 Connections with 0-10V thermostats.....	16	9.12 Operation at maximum ventilation speed	40
6. Feet kit	17	9.13 Key lock.....	41
6.1 Assembly.....	17	9.14 Reduce brightness to minimum.....	41
7. 2-way/3-way valve unit kit.....	18	9.15 Deactivation	41
7.1 List of hydraulic accessories	18	9.16 Room temperature probe regulation offset.....	41
7.2 Pipeline diameter	18	9.17 Switching off for long periods.....	41
7.3 Access to inner parts.....	18	9.18 Error signals	42
7.4 Mounting the thermostatic head.....	19	10. 4-speed temperature controller kit	43
7.5 Lockshield adjustment.....	19	10.1 LCD electronic control panel	43
7.6 Way valve with thermo-electric head kit	21	10.2 LED indications	43
7.7 Way valve with thermo-electric head deviator valve kit.....	22	10.3 Key function.....	43
7.8 Connections	24	10.4 General On Switch	43
7.9 2-way valve unit kit	25	10.5 Activation	44
7.10 3-way valve unit kit	26	10.6 Heating/cooling operation modes setting.....	44
8. Cooler-convactor, heating, cooling and dehumidification	27	10.7 Stand By.....	44
8.1 Fundamental safety rules	27	10.8 Temperature selection	44
8.2 Description	27	10.9 Ventilation speed regulation.....	44
		10.10Key lock.....	45
		10.11Reduce brightness to minimum.....	45
		10.12Deactivation	45
		10.13Switching off for long periods.....	45
		10.14Error signals	45
		11. Maintenance	46
		11.1 Cleaning the outside.....	46
		11.2 Cleaning air suction filter	46
		11.3 Energy saving tips	47

12. Troubleshooting 48
12.1 Table of anomalies and remedies 48

1. GENERAL

1.1 General warnings

-  This instruction is an integral part of the booklet of the appliance on which the kit is installed. Please consult this booklet for general warnings and fundamental safety rules.
-  This manual is designed only for the qualified and authorised installation technician, who must be sufficiently trained and in possession of all psycho-physical requirements as per the law.
- All operations must be carried out with care and according to best practices, and in compliance with workplace safety regulations.
-  After unpacking, check that the contents are intact and that all parts are included. If not, contact the agent who sold the appliance to you.
-  It is forbidden to modify the safety or adjustment devices without authorisation from and indications of the manufacturer.
-  It is forbidden to dispose of, or leave in the reach of children, the packaging materials which could become a source of danger.
-  Repairs or maintenance must be performed by the Technical Assistance Service or by qualified personnel in accordance with this manual. Do not modify or tamper with the appliance as this could create dangerous situations and the manufacturer will not be liable for any damage caused.

2. MODULATING TEMPERATURE CONTROLLER KIT

2.1 Assembly, set-up and connection

The controllers have two independent clean contacts for controlling a refrigerator unit, a boiler and a presence input. The 2 tube versions have a 230V output to power the summer and winter solenoid valve.

The 10 k Ω water temperature probe positioned in the

compartment on the battery regulates the minimum level when heating (30°C) and the maximum level when cooling (20°C).

The board also has a function when there is no water probe, in such cases the fan stop thresholds are ignored.

2.2 Assembly

Slide the control panel into its housing in the upper part of the device and fix it with the two fixing screws (ref. A).

To install the connection box:

- open the box (ref. B);
- lock the lower tooth into its hole (ref. C) on the side of the device;
- hook the upper part of the box to the side (ref. D);
- fix it with the two fixing screws (ref. E);
- connect the grounding cable to the fan coil body (ref. M) using the fixing screws (the minimum force that must be applied for tightening screws must be around 2N);
- connect the fast connector of the MOTOR to the other on the board (ref. I) *;
- on the two GRID block terminals (ref. L) there is a bridge which must not be removed.
- For other versions, remove the bridge and connect the two terminals originating on the grill safety microswitch*;

- connect the water probe to the H2 connector on the device.

The water temperature probe controls the temperature inside the batteries and determines when the fan starts according to pre-set parameters (minimum operation in winter and maximum in summer).** Check that they are correctly inserted into the compartment on the battery.

- Connect the electrics, tidy cables and fix them with the three clevises supplied (ref. G);
- close the box with the 4 screws (ref. H);
- refit the vanity plate on the side of the unit;
- tighten the upper screws on the control panel;
- place the screw head covers in their housing on the control panel;

* For versions with hydraulic connections on the right, refer to the relevant paragraph

** The regulation also works without a water probe connected

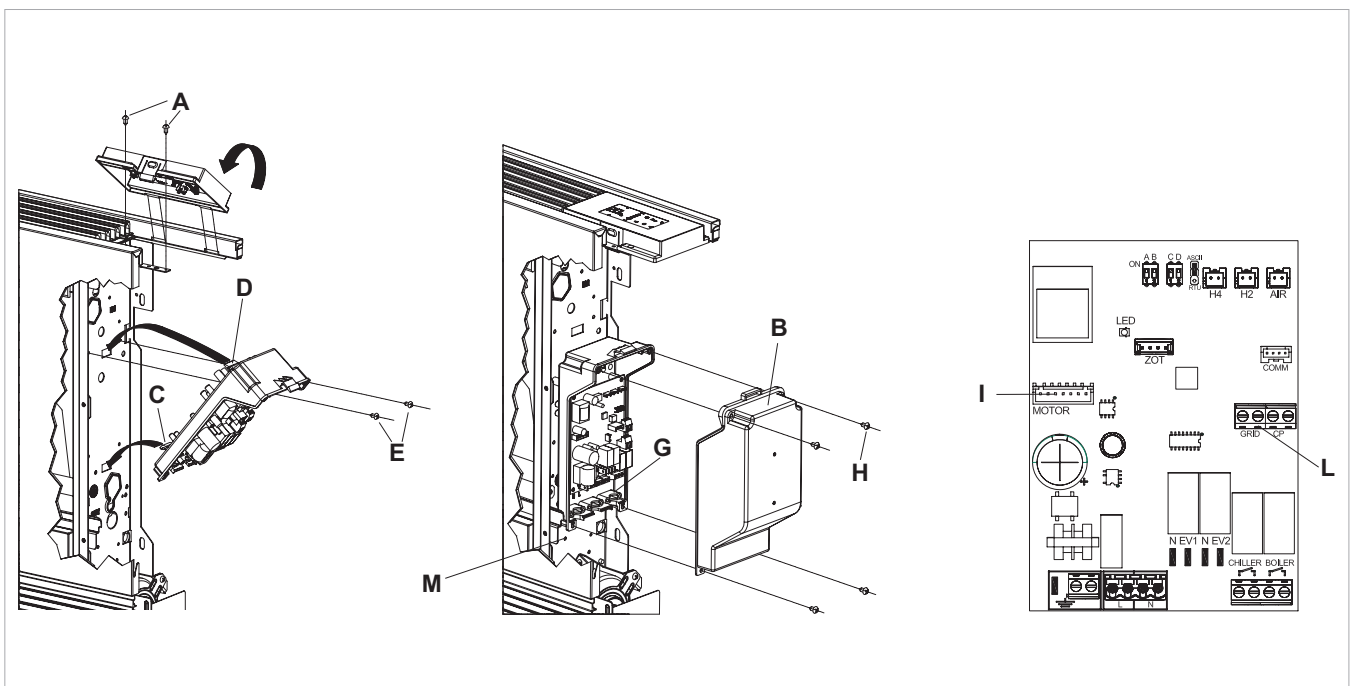

2.3 Set-up of auxiliary dip-switch functions B and C

There are two dip switches on the controller circuit board for configuring unit operation as per requirements.

- The night-time heating operation logic is modified by using dip switch C:
- in the ON position, the fan is always off, and heats the room using radiation and natural convection, as with traditional radiators; in the off position it operates as a normal fan.
- By positioning dip switch B to ON, when cooling, the fan operates at the minimum speed even after having

reached the set point, to allow for more uniform operation of the temperature probe and to avoid layering in the air. With the cursor in the OFF position, the functions are cycled (4 minutes ON, 10 minutes OFF).

2.4 CP presence contact input connection

On closing the contact connected to the CP input (ref. A) the panel is placed in stand-by mode.

If the contact is open the unit is active, if the contact is closed it is deactivated when a key is pressed the symbol flashes. ⚠

The input cannot be connected in parallel to that of other electronic boards (use separate contacts).

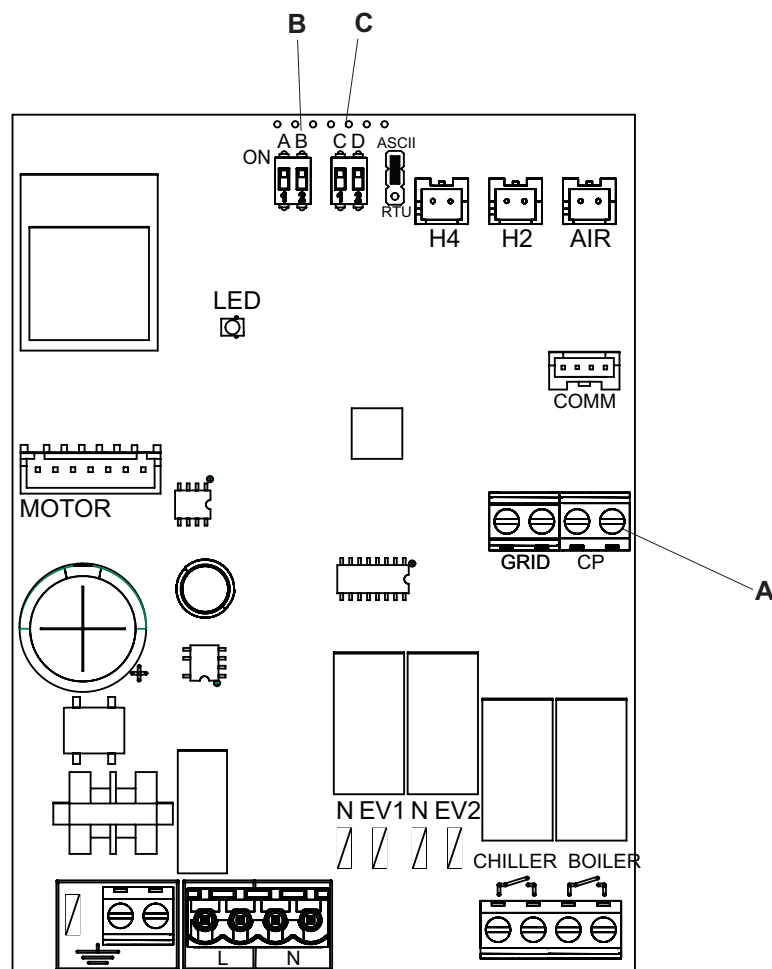

2.5 Air temperature probe assembly

- To position the temperature probe (ref. A):
- pass the probe through the hole on the shoulder (ref. B)
- insert the probe into the lower hole (ref. C)
- fix the probe on the relevant hook (ref. D)

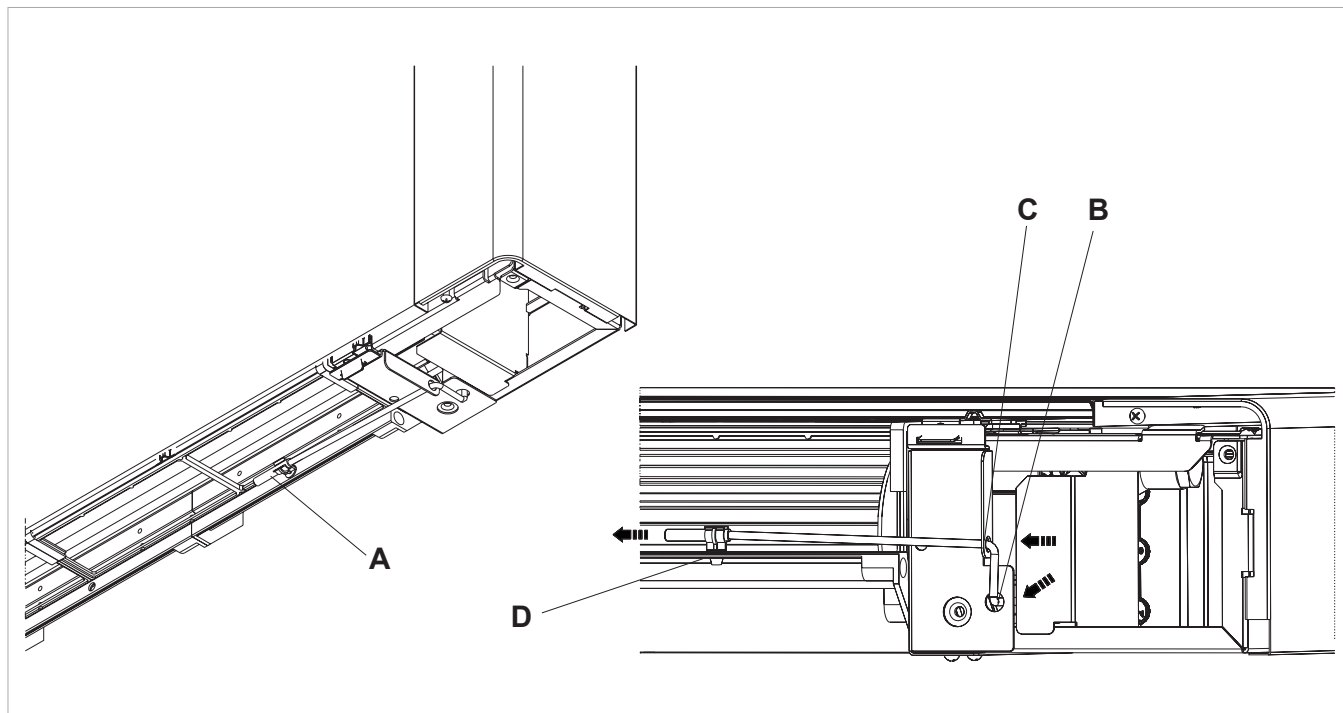

2.6 Connections

H2*	water temperature probe 10 k Ω
AIR	air temperature probe 10 k Ω
M1	DC inverter fan motor
S1	grill safety micro-switch
Y1	water solenoid valve (230V/ 50Hz 1A output voltage)
L-N	electrical power supply 230V/50Hz

BO	boiler consent output (free contact max 1A)
CH	chiller consent output (free contact max 1A)
CP	presence input sensor (if closed, the fan coil unit is placed in standby)
*	If after switching the power on the board detects the probe, start-up occurs in normal conditions with the minimum water temperature when heating (30°C) and maximum when cooling (20°C). The board also has a function when there is no probe, in such cases the fan stop minimum and maximum thresholds are ignored.

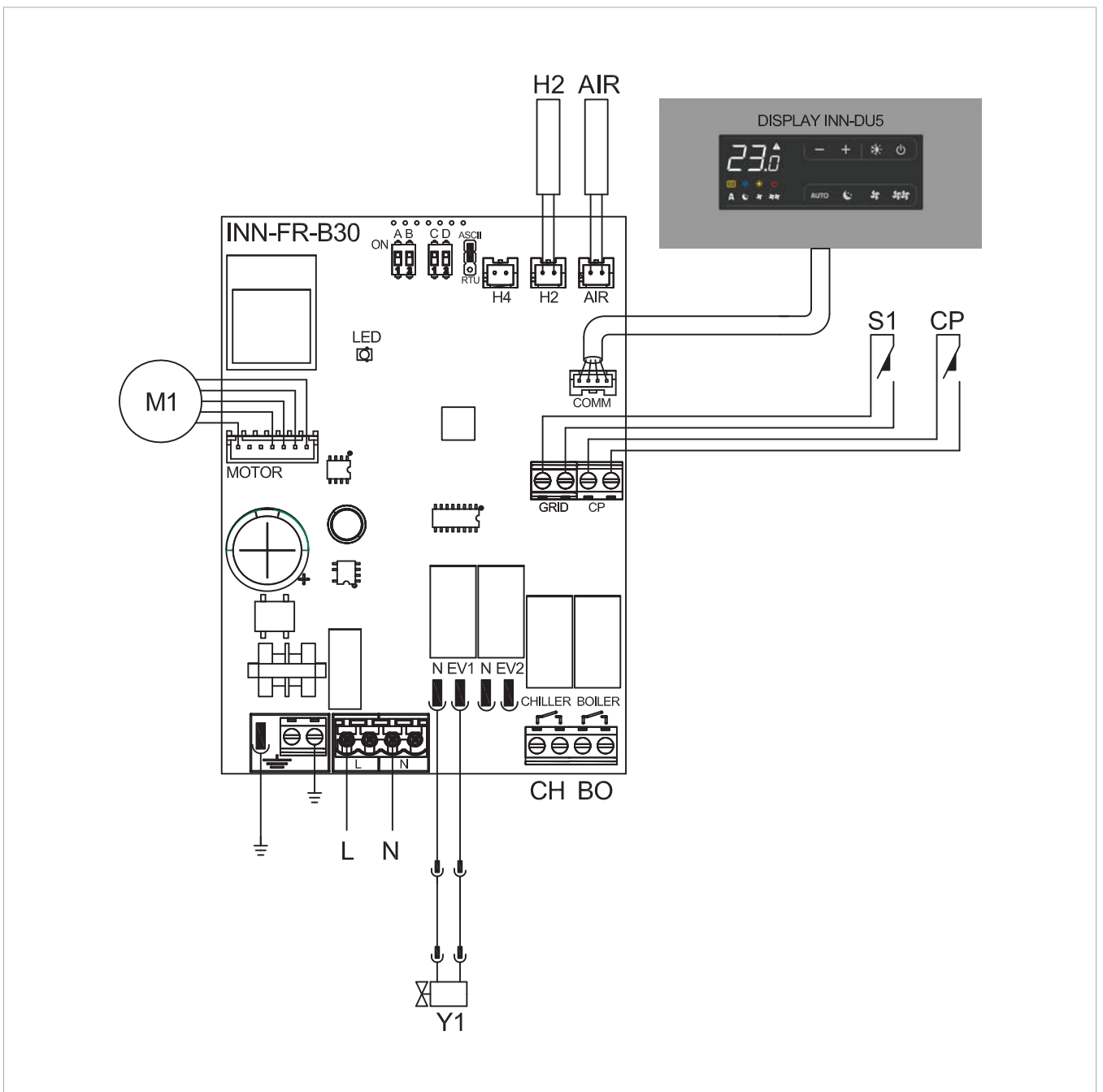

3. 4-SPEED TEMPERATURE CONTROLLER KIT

3.1 Assembly and connections

The on-board controller with speed selector and ON/OFF key, room thermostat adjustable from 5 to 40°C, winter summer selector and minimum winter temperature function

(30°C) and maximum summer temperature (20°C) is suitable for fitting on board the unit and has a 230V - 1A output for controlling a solenoid valve.

3.2 Assembly

Slide the control panel into its housing in the upper part of the device and fix it with the two fixing screws (ref. A). To install the board:

- connect the grounding cable to the unit structure (ref. M) using the fixing screws (the minimum force that must be applied for tightening screws must be around 2N);
- connect the fast connector of the MOTOR to the other on the board (ref. I) *;
- N.B.:** should the board not be fitted in the factory, the fan motor must be rotated 180° due to the length of the standard fan coil cable.
- on the two GRID block terminals (ref. L) there is a bridge which must not be removed.
- For other versions, remove the bridge and connect the two terminals originating on the grill safety microswitch;
- N.B.:** should the two brown terminals on the unit be too short, replace them with those included in the kit packaging.
- connect the water probe connector H2 (ref. F) on the

unit.

The water temperature probe controls the temperature inside the batteries and determines when the fan starts according to pre-set parameters (minimum operation in winter and maximum in summer). Check that they are correctly inserted into the compartment on the battery.

- make the electrical connections, tidy the cabling;
- refit the vanity plate on the side of the unit;
- tighten the upper screws on the control panel;
- place the screw head covers in their housing on the control panel;
- * For versions with hydraulic connections on the right, refer to the relevant paragraph.

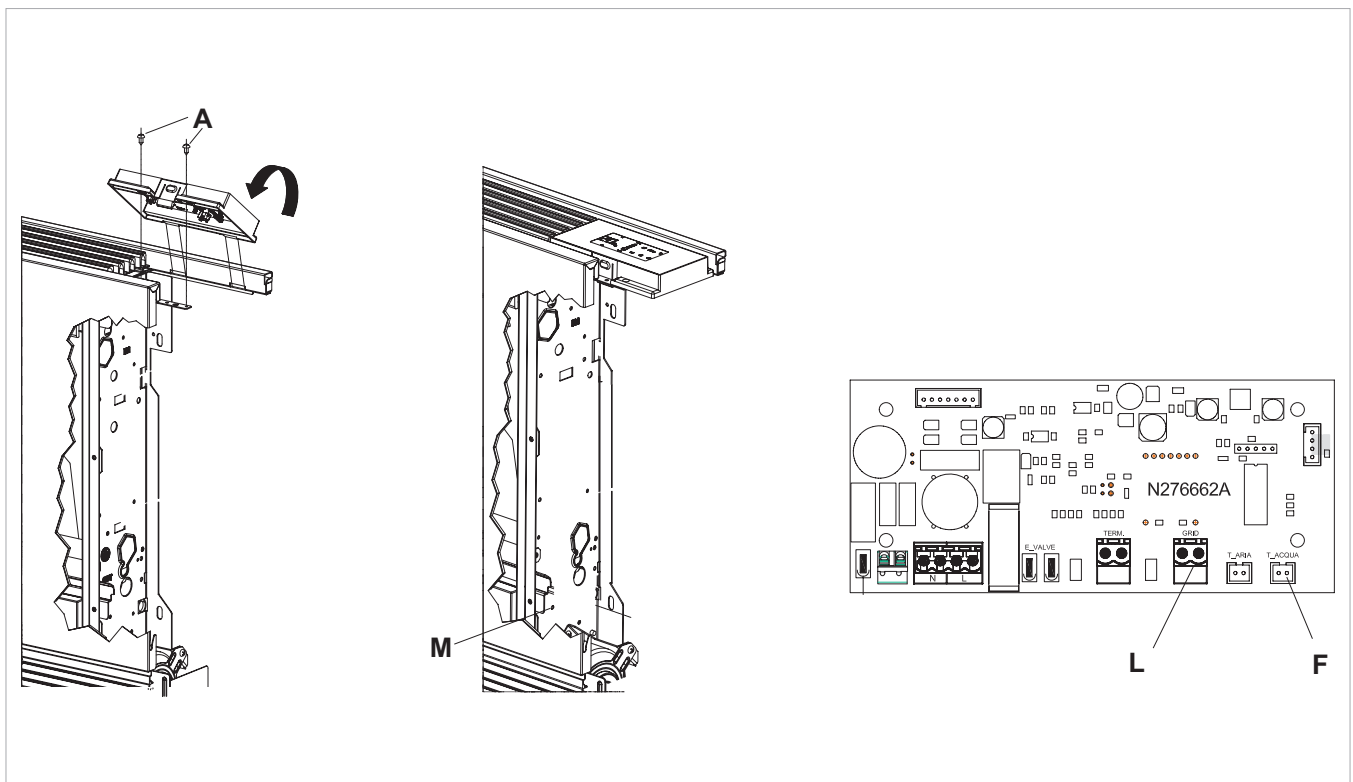

3.3 Air temperature probe assembly

- To position the temperature probe (ref. A):
- pass the probe through the hole on the shoulder (ref. B)
- insert the probe into the lower hole (ref. C)
- fix the probe on the relevant hook (ref. D)

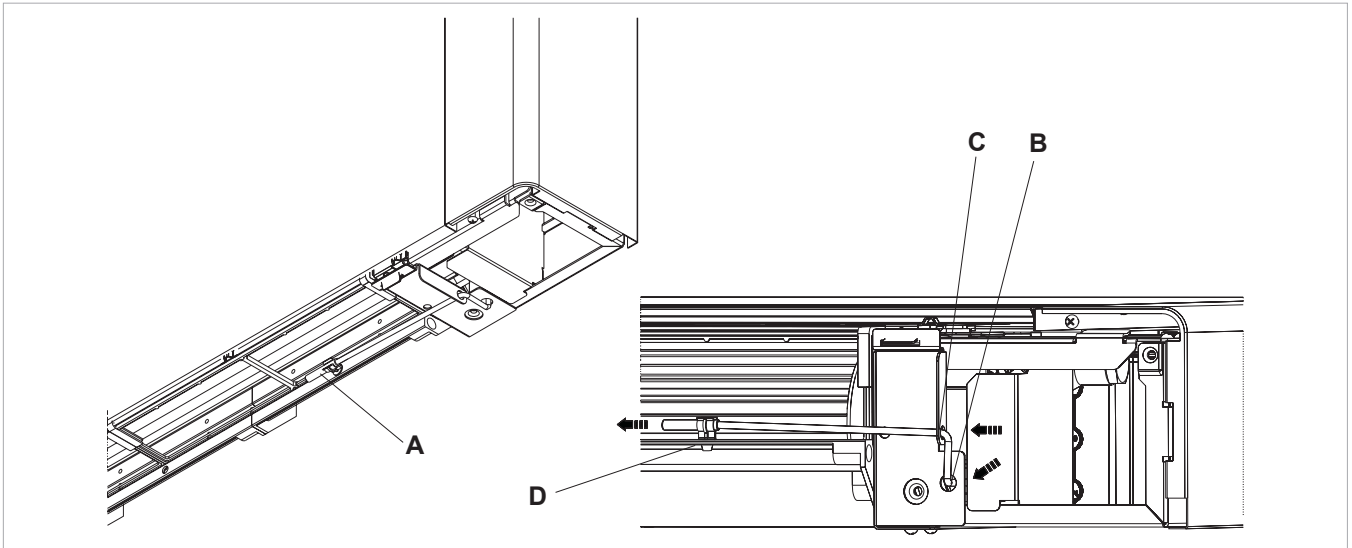

3.4 Connections

H2	water temperature probe 10 kΩ
M1	DC inverter fan motor
S1	grill safety micro-switch

Y1	water solenoid valve (230V/ 50Hz 1A output voltage)
L-N	230V/50Hz electrical power supply
AIR	air temperature probe 10 kΩ

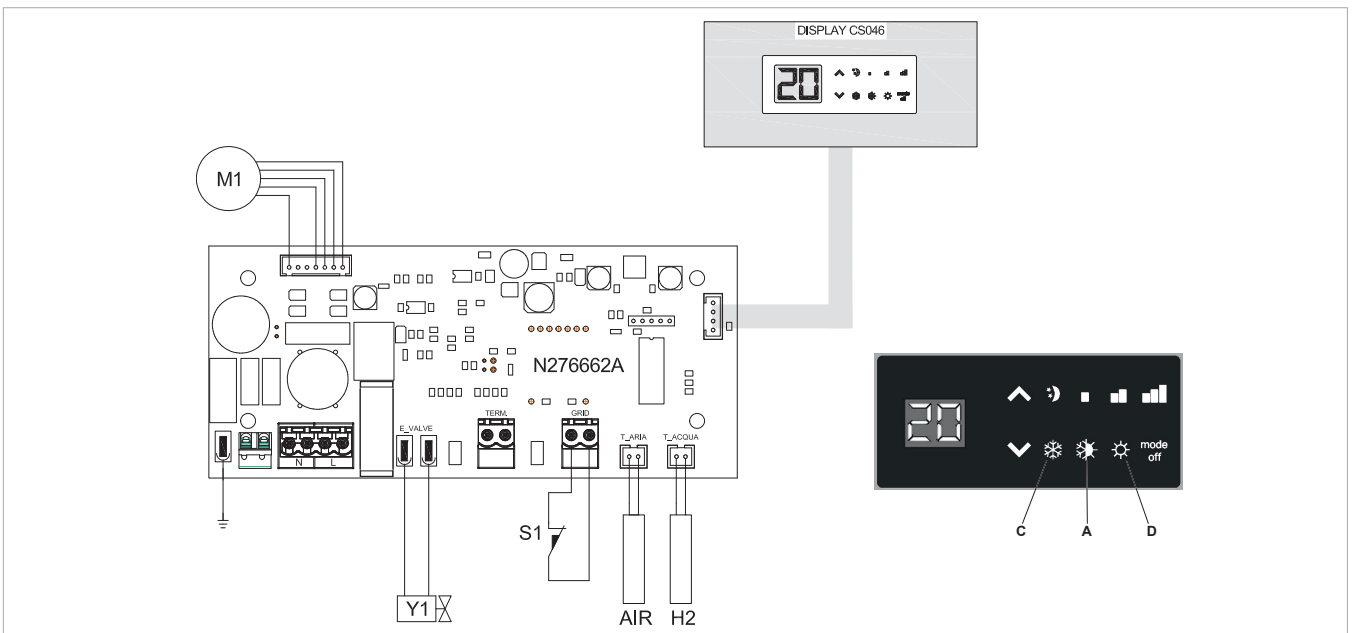

3.5 Water probe kit management

If the board detects the water temperature detecting probe on the device positioned in the relevant compartment of the battery, it starts in normal conditions. If the probe is not connected, its absence is indicated by the blue and red LEDs flashing together, and operation stops.

To confirm operation without the probe, press and hold the summer/winter button for 5 seconds (ref. A).

This condition is saved by the board for future start-ups.

In any case, as and when the probe is connected, the unit returns to normal operation with temperature thresholds.

If the unit operates with the probe connected and the water temperature is not suitable for active functioning (over 20°C when cooling, under 30°C when heating) the fan will stop and the anomaly will be indicated by the corresponding LED flashing (cooling: blue C or heating: red D).

4. UNIVERSAL CARD KIT FOR COMMERCIAL TEMPERATURE CONTROLLER

4.1 Assembly and connections

Assembled on-board the unit, this card allows the regulation of the motor with fixed speeds; it can be combined with control panels with thermostat and with all control panels

available in the market.

It has a 230 V output to pilot the summer and winter solenoid valve.

4.2 Assembly

Slide the blanking panel into its housing in the upper part of the device and fix it with the two fixing screws (ref. A).

To install the connection box:

- open the box (ref. B);
- lock the lower tooth into its hole (ref. C) on the side of the device;
- hook the upper part of the box to the side (ref. D);
- fix it with the two fixing screws (ref. E);
- connect the grounding cable to the unit body (ref. M) using the fixing screws (the minimum force that must be applied for tightening screws must be around 2N);
- on the two SW GRL block terminals (ref. L) there is a bridge which must not be removed.

- For other versions, remove the bridge and connect the two terminals originating on the grill safety microswitch*;
 - connect the fast connector of the MOTOR to the other on the board (ref. I);
 - Connect the electrics, tidy cables and fix them with the three clevises supplied (ref. G);
 - close the box with the 4 screws (ref. H);
 - refit the vanity plate on the side of the unit;
 - tighten the upper screws on the blanking panel;
 - place the screw head covers in their housing on the blanking panel;
- * For versions with hydraulic connections on the right, refer to the relevant paragraph.

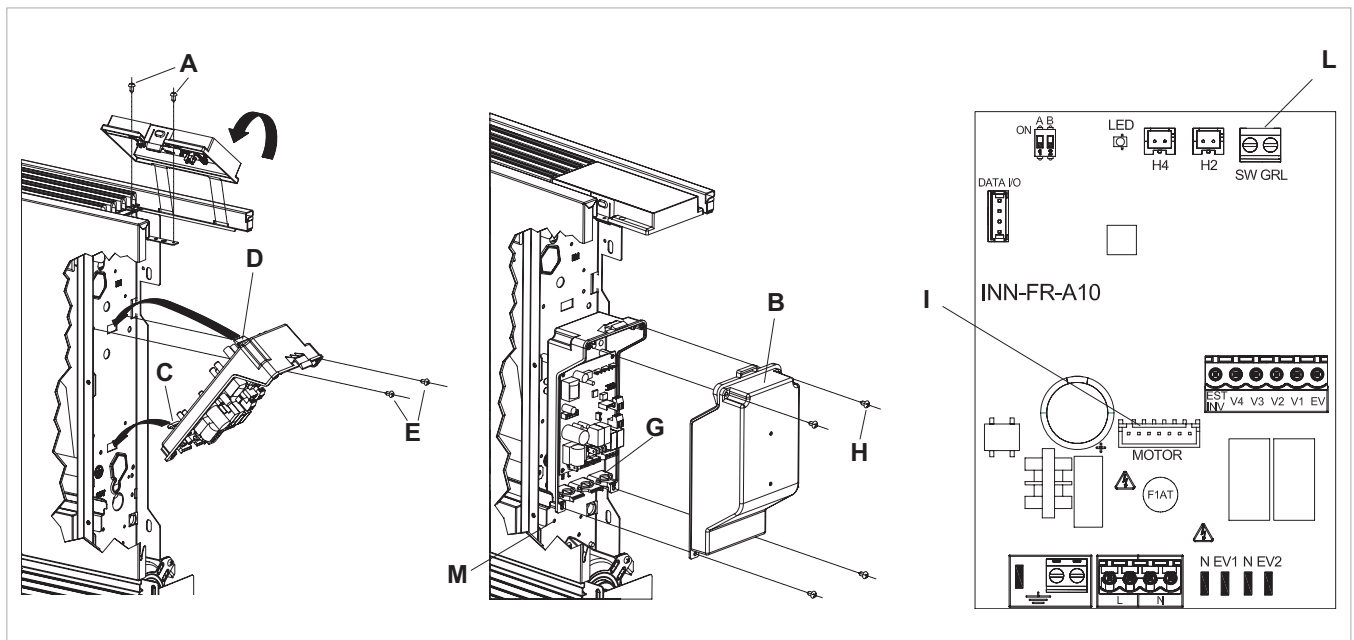

4.3 Connection diagram with 3-speed thermostat

Make the electrical connections to a thermostat fit for use according to the diagram.

L-N	electrical supply 230V-50Hz
EV	solenoid valve permission input
V1	maximum fan speed
V2	medium fan speed
V3	minimum fan speed
V4	supersilent speed
E	heating selection input, cooling See paragraph on Water Probe Management
Y2	output for mobile suction panel servo (power output 230V/ 50Hz 1A)
Y1	water solenoid valve (230 V/ 50 Hz 1A output voltage)

M1	DC inverter fan motor
S1	safety micro-switch for grill
TA	3-speed room thermostat (to be purchased, installation and connection to be made by installer)
CV	thermostat permission
SV	speed selector
H2*	water temperature probe (10 k Ω)
*	positioned in the on-board battery. See paragraph on Water Probe Management

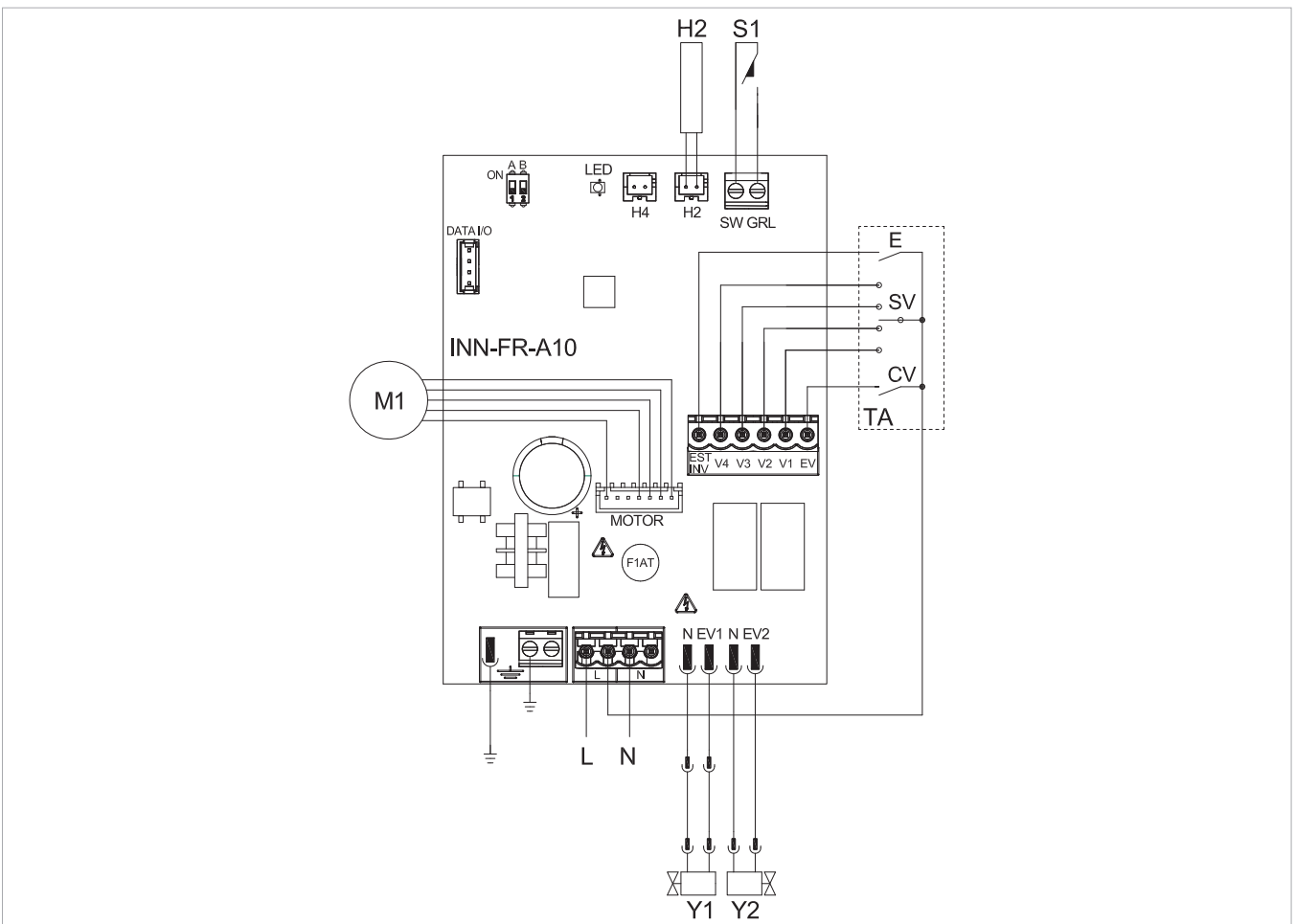

4.4 Connections with 3-speed thermostats

The CV input is the board ON/OFF which when open puts the board in stand-by. It must be bridged to the L terminal on the 230V power supply to activate solenoid valve Y1. The 4 speed inputs V1, V2, V3 and V4, when bridged to the L terminal on the 230V power supply, activate the fan if the S1 input to which the grill safety microswitch is connected is closed. The sequence is: maximum speed (1400 rpm on terminal V1), medium speed (1100 rpm on terminal V2), minimum speed (680 rpm on terminal V3) and supersilent speed (400 rpm on terminal V4). Connect the three thermostat speeds to 3 out of the 4 available inputs as per the characteristics and use of the

room: connect, for example, medium speed V2, minimum V3 and supersilent V4 for residential applications, when greater silence is required, whereas V1, V2 and V3 can be connected for commercial applications where the thermal yield is more important. If multiple inputs are simultaneously closed, the motor will run at a number of revs equal to that of the connection with the highest speed. Multiple cards can be connected in parallel to a single thermostat, also using different speeds.

4.5 LED signals

The LED (ref. A) is off if the CV input is not closed (stand-by condition).

It turns on when the CV contact is closed and indicates normal operation.

- Flashes frequently if the grille microswitch S1 is activated due to the filter cleaning operation
- 1 flash + pause indicates a fan stoppage alarm due to unsuitable water (with H2 water probe connected).
- 2 flashes + pause due to a motor alarm (e.g. blockage caused by foreign objects, faulty rotation sensor).

- 3 flashes + pause indicates a disconnected or faulty water probe alarm.

4.6 Water probe management with 3-speed thermostat

If the board is used with electromechanical thermostats, or with other commercial controllers with water probe, the on-board probe H2 should not be connected and the fan is controlled by the remote control.

If on the other hand the controller is not set up for managing the water probe, this function can be performed by the board, by connecting the 10 k Ω probe on the battery to the H2 connector on the board (ref. B).

In this case the board carries out the minimum temperature function for heating operations and maximum temperature function for cooling. Therefore, if the water temperature is not suitable for active operation (above 20°C when cooling, under 30°C when heating) the fan is stopped and the anomaly is signalled by a single flash + pause of the LED (ref. A).

The discrimination between heating/cooling is actuated via the Summer-Winter (ref. C) input of the board: leaving it open the board activates heating, closed activates cooling.

If after having connected the probe it is disconnected or measures incorrect values (e.g. installation of 2 k Ω probe in the place of the 10 k Ω probe) the anomaly is signalled by 3 flashes + pause of the LED (ref. A) and operation is stopped.

To confirm operation without a probe, turn the power to the board off and then on again.

This condition is saved by the board for future start-ups.

In any case, as and when the probe is connected, the unit returns to normal operation with temperature thresholds.

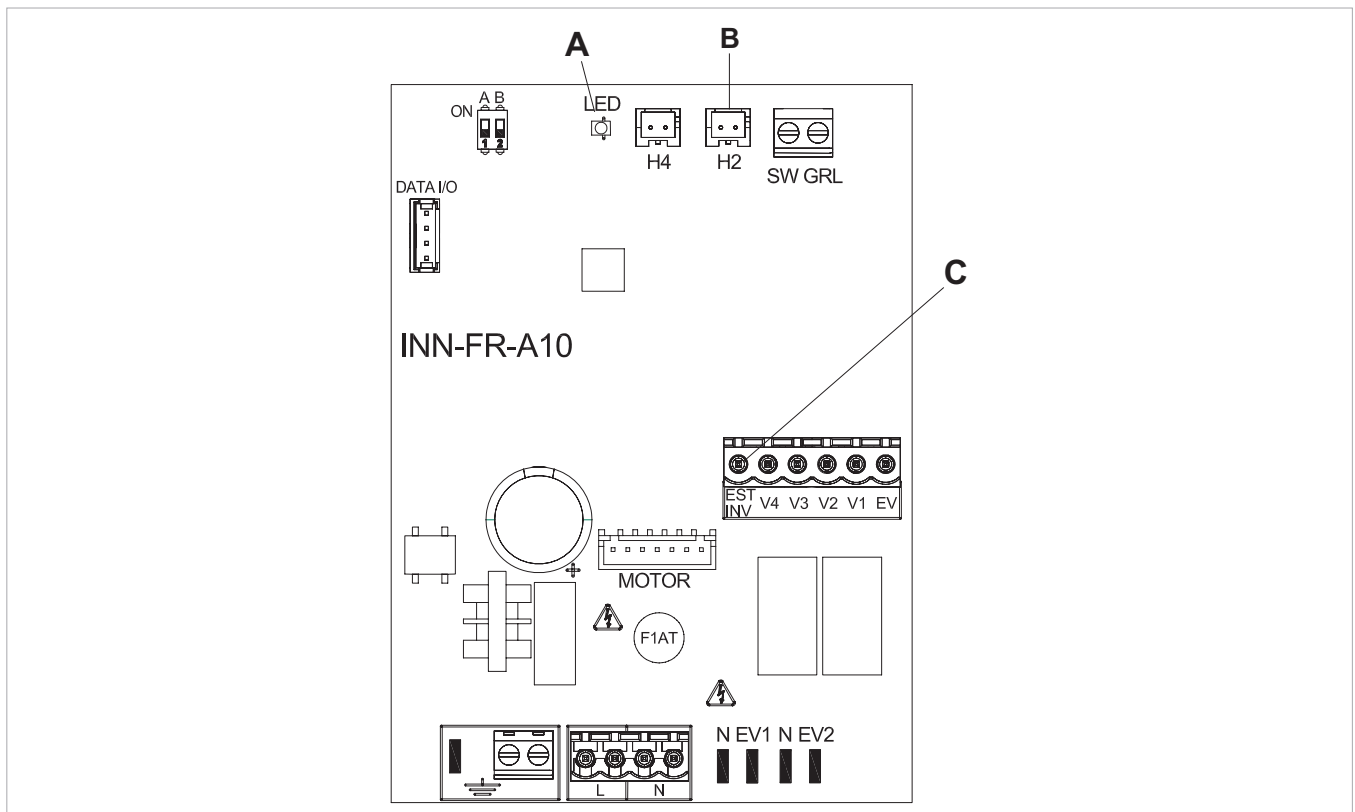

5. 0-10 V DEMAND BOARD KIT

5.1 Assembly and connections

When fitted on board the machine it allows for managing the motor, with modulated speed; motor regulation can be made using an analogue 0-10V DC input with 25 k Ω impedance.

For board control outputs these impedance values must be considered, especially when controlling more than one unit in parallel.

It has a 230 V output to pilot the solenoid valve.

5.2 Assembly

Slide the blanking panel into its housing in the upper part of the device and fix it with the two fixing screws (ref. A).

To install the connection box:

- open the box (ref. B);
- lock the lower tooth into its hole (ref. C) on the side of the device;
- hook the upper part of the box to the side (ref. D);
- fix it with the two fixing screws (ref. E);
- connect the grounding cable to the unit structure using the fixing screws (the minimum force that must be applied for tightening screws must be around 2N);
- on the two GRID block terminals (ref. I) there is a bridge which must not be removed.

- For other versions, remove the bridge and connect the two terminals originating on the grill safety microswitch;* connect the fast connector of the MOTOR to the other on the board (ref. H);
- Connect the electricians, tidy cables and fix them with the three clevises supplied (ref. F);
- close the box with the 4 screws (ref. G);
- refit the vanity plate on the side of the unit;
- tighten the upper screws on the blanking panel;
- place the screw head covers in their housing on the blanking panel;

* For versions with hydraulic connections on the right, refer to the relevant paragraph.

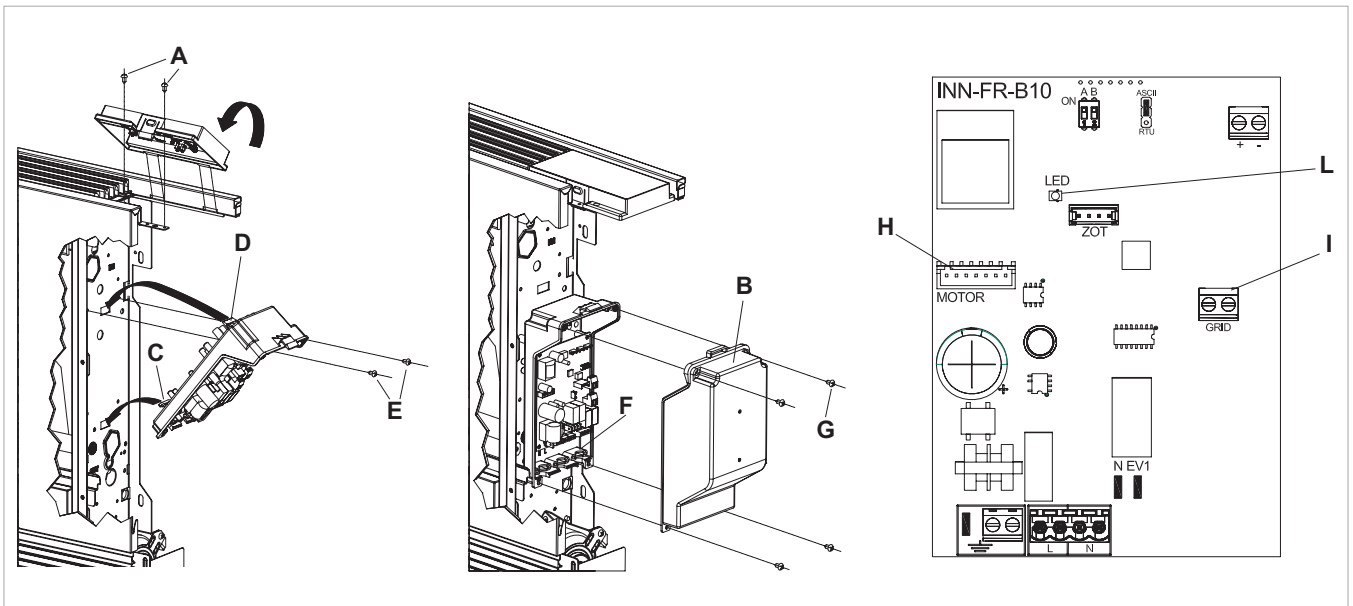

5.3 LED signals

The LED (ref. L) is off if the input signal is less than 0.9V. It turns on with values greater than 1V and indicates normal operation.

- Flashes frequently if the grille microswitch S1 is activated due to the filter cleaning operation
- 2 flashes + pause due to a motor alarm (e.g. blockage caused by foreign objects, faulty rotation sensor).

5.4 Connection diagram with 0-10V DC thermostats / signals

Make the electrical connections to a thermostat fit for use according to the diagram

L-N	Electrical power supply 230V-50 Hz
10V	Appliance piloting input 0÷10 V
Y1	water solenoid valve (230V/ 50Hz 1A output voltage)

Y2	output for mobile suction panel servo (power output 230 V/ 50Hz 1A)
M1	DC inverter fan motor
S1	safety micro-switch for grill

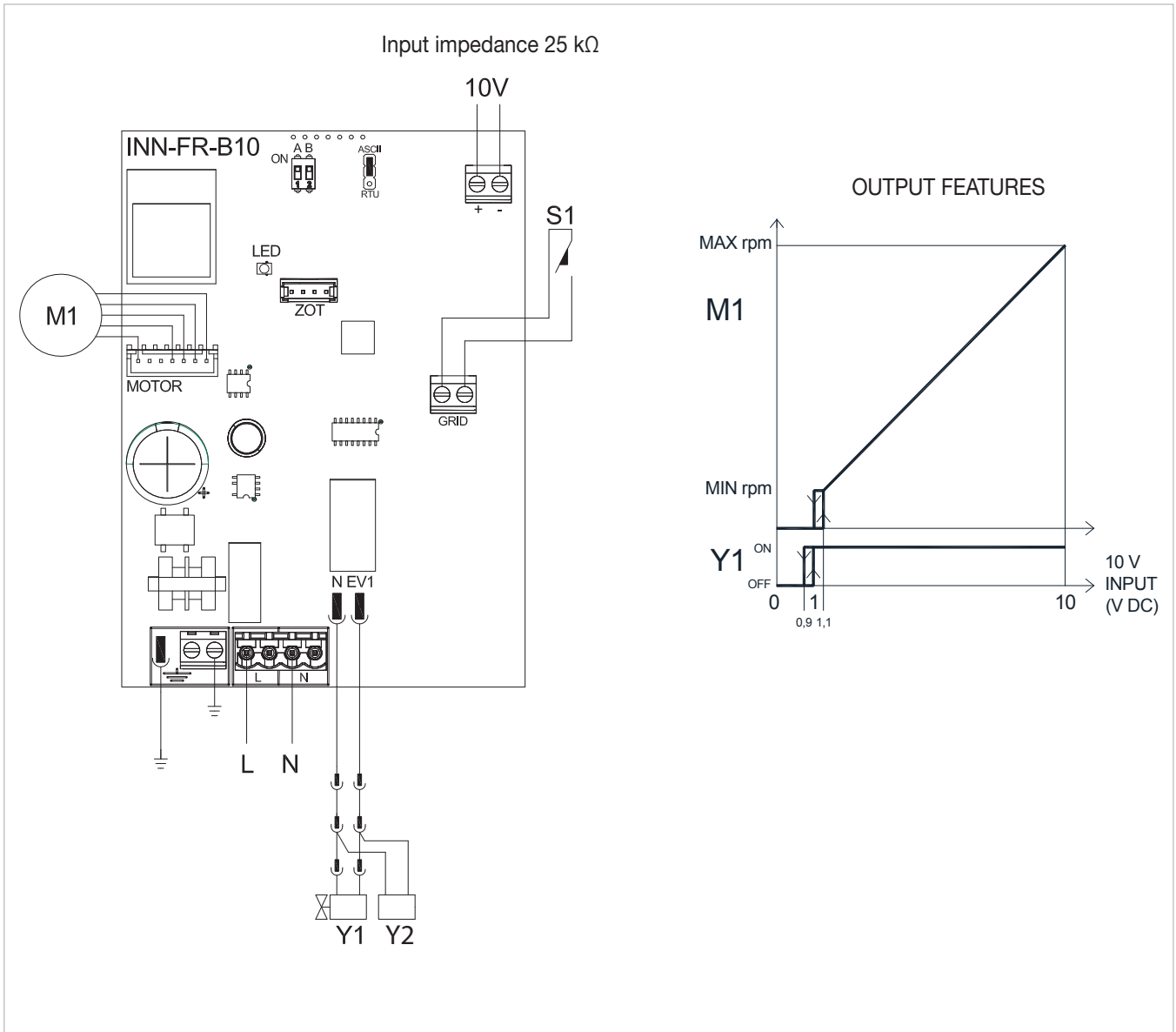

5.5 Connections with 0-10V thermostats

The 10V input, if the S1 input which the grill safety micro switch is connected to is closed, activates solenoid valve Y1 and regulations fan revolutions.

The speed "ramp" provides for linear regulation from the minimum value (400 rpm) to the maximum value (1,400 rpm)

for voltage values $\geq 1.1V \div 10 V DC$.

The motor is off when values are lower than 1V DC.

The Y1 solenoid valve is activated for power values $> 1V DC$ and switches off then the power drops below 0.9V DC.

6. FEET KIT

6.1 Assembly

⚠ This instruction is an integral part of the booklet of the appliance on which the kit is installed. Please consult this booklet for general warnings and fundamental safety rules.

These accessories cover the hydraulic pipes coming up through the floor. They should be fitted on Hydro FS appliances anchored to the back wall.

They have a sleek design and are also easy to remove for maintenance or cleaning.

These Feet should not be used to anchor the terminal to the ground.

- Rest the back of the appliance on a horizontal surface;
- screw the four threaded supports provided to the structure;
- stand the appliance up again and fasten it to the wall;
- fit the two covers to the supports.

A threaded supports

B supports cover

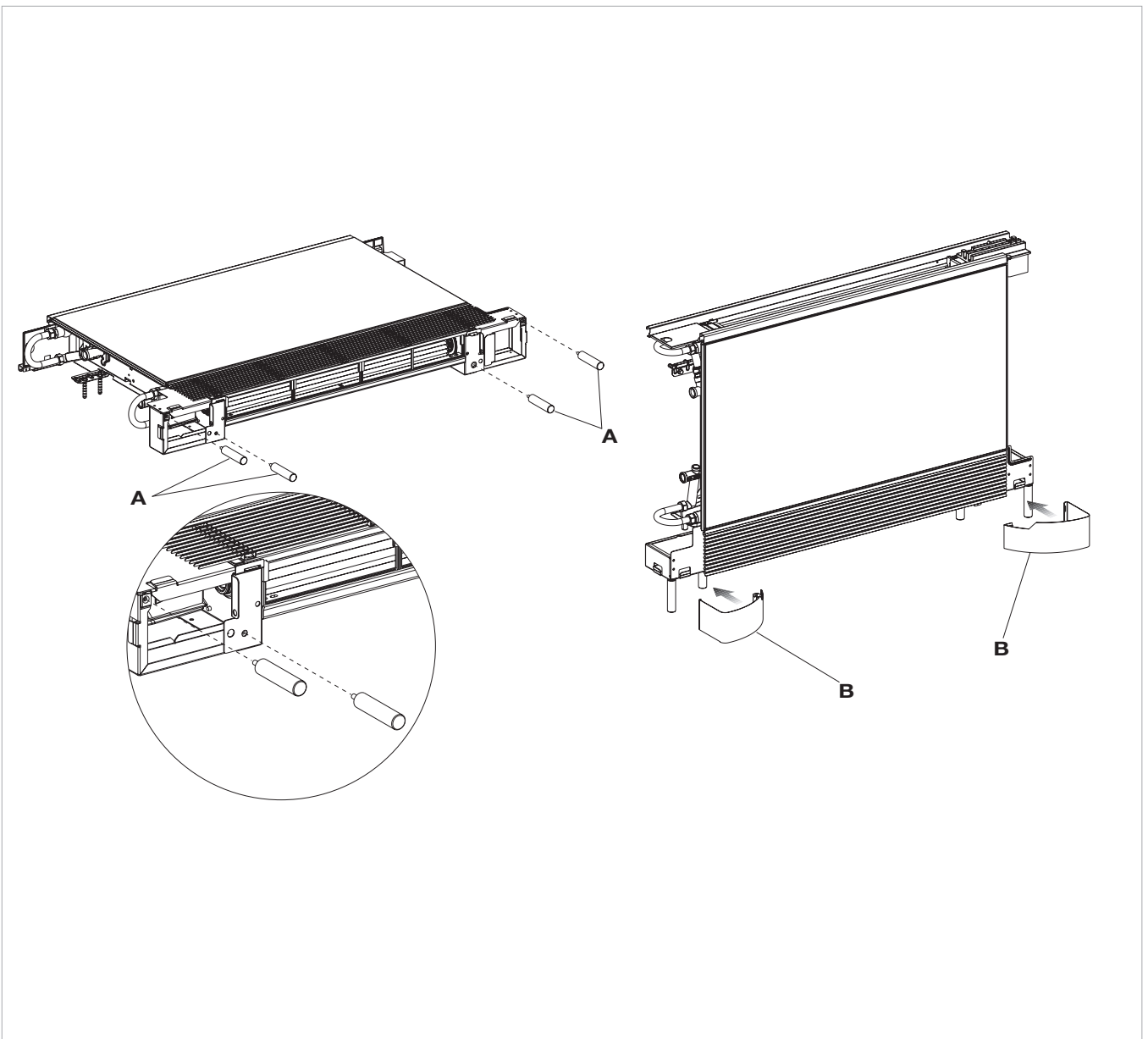

7. 2-WAY/3-WAY VALVE UNIT KIT

⚠ To avoid penalising the performance of the system the water inlet and outlet must be as indicated in the various figures.

⚠ For a rapid and correct assembly of the components follow carefully the sequences described in the various sections.

⚠ This instruction is an integral part of the booklet of the appliance on which the kit is installed. Please consult this booklet for general warnings and fundamental safety rules.

7.1 List of hydraulic accessories

- 2-way valve unit with thermo-electric head kit.
- 3-way deviator valve unit with thermo-electric head deviator valve kit.

7.2 Pipeline diameter

The minimum internal diameter that must be respected for the pipelines of the hydraulic connections varies according

to the model:

	U.M.	200	400	600	800	1000
support covers	mm	12	14	16	18	20

7.3 Access to inner parts

- Lift it up the side panels.
- Move orizontally to remove.

A	Left panel
B	Right panel

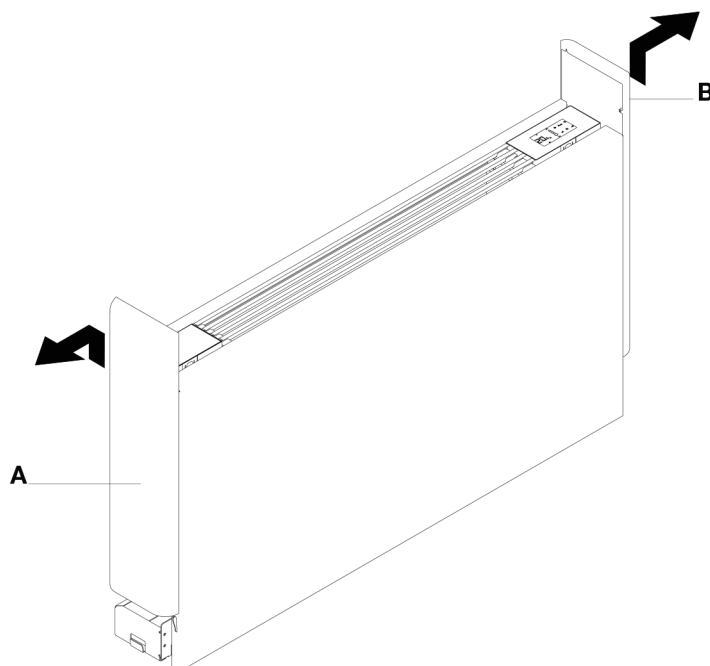

7.4 Mounting the thermostatic head

Tighten the plastic disc to the valve body. Attach the head to the valve body.

To facilitate the system mounting, filling and venting operations, even without electric power, the thermostatic head is supplied with a tool that keep it open.

⚠ Remove the tool from the thermostatic head before starting the system.

A	plastic tool
B	valve body

C	thermostatic head
----------	-------------------

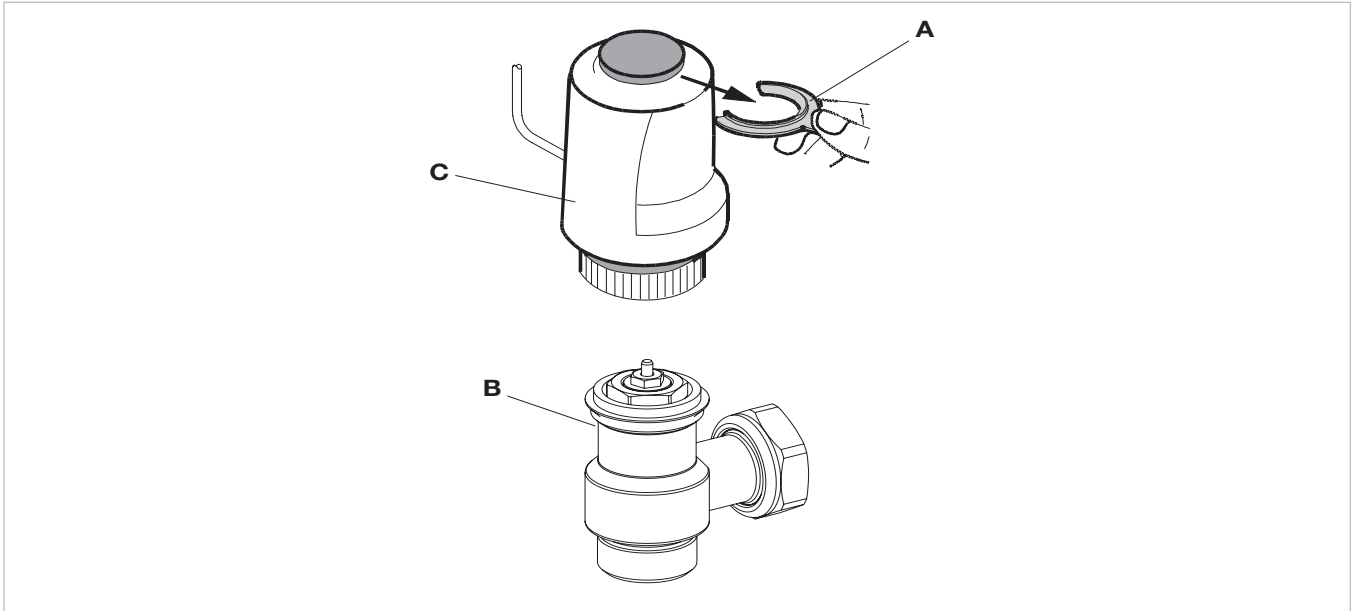

7.5 Lockshield adjustment

The lockshields supplied with the hydraulic kits provide an adjustment that balances the system load losses. To ensure a correct adjustment and balancing of the circuit, follow the procedure indicated below:

- With a screwdriver, loosen and remove the slotted grub screw inside the hexagonal head.
- Close the adjustment screw using a 5 mm Allen key (A)
- Re-tighten the slotted grub screw then mark the reference point for the adjustment with an "x" (B).

- Align the screwdriver with the "x", then open with a number of turns (C) according to diagram Äp-Q shown on page 22.

⚠ The number of turns refers to the micrometric screw

Then fully open the screw (D). Now the pre-adjustment has been set and will not change if there are repeated openings or closings with the Allen key.

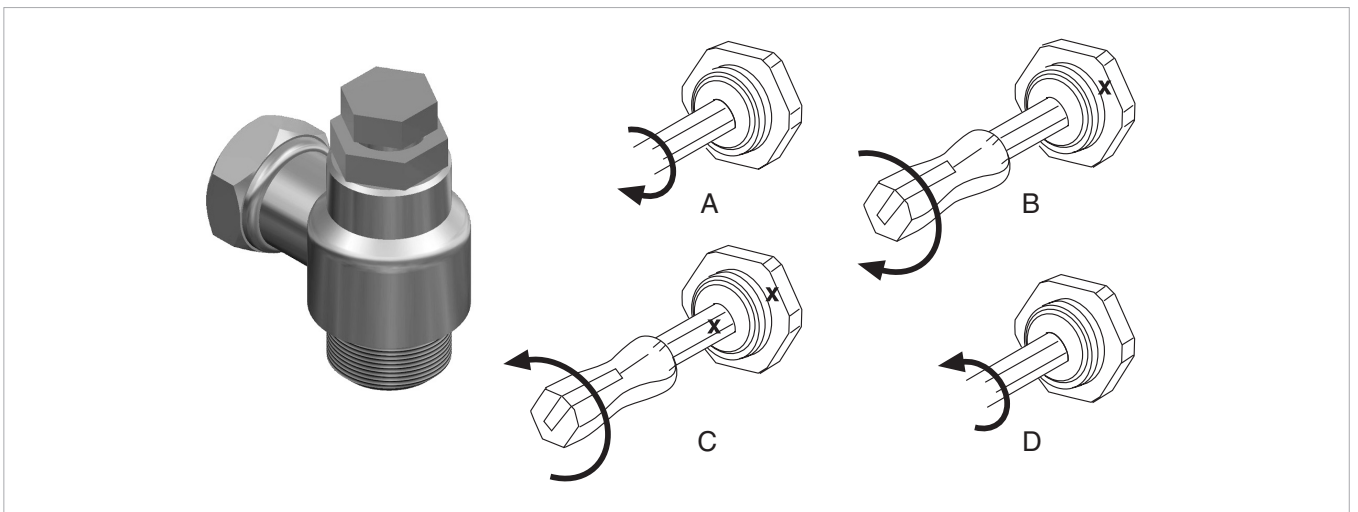

Load losses based on the adjustment of the lockshield present in all kits.

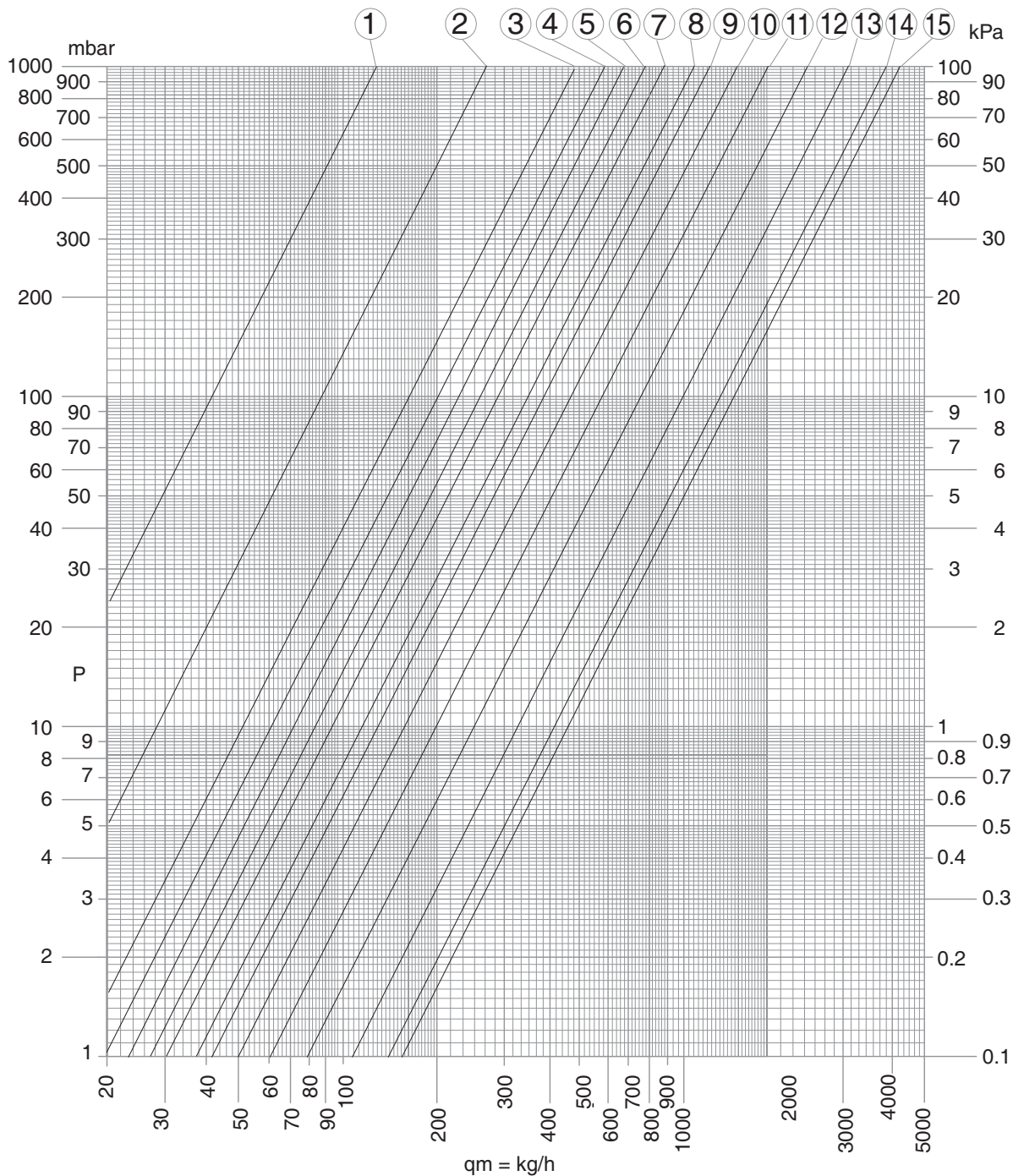

POS.	1	2	3	4	5	6	7	8	10	11	12	13	14	15
ADJ	1 ^{2/4}	2	2 ^{1/4}	2 ^{1/2}	2 ^{3/4}	3	3 ^{1/4}	3 ^{2/4}	4	4 ^{1/2}	5	6	8	T.A.
Kv	0.13	0.28	0.49	0.62	0.70	0.82	0.95	1.33	1.57	1.95	2.47	3.34	4.18	4.52

7.6 Way valve with thermo-electric head kit

Consists of an automatic valve with thermo-electric head and a lockshield, fitted with micrometric adjustment, capable of balancing the system load losses.

The kit contains the insulation to be mounted on the valve and on the lockshield.



load losses in completely open position of 2-way valve present in kits.

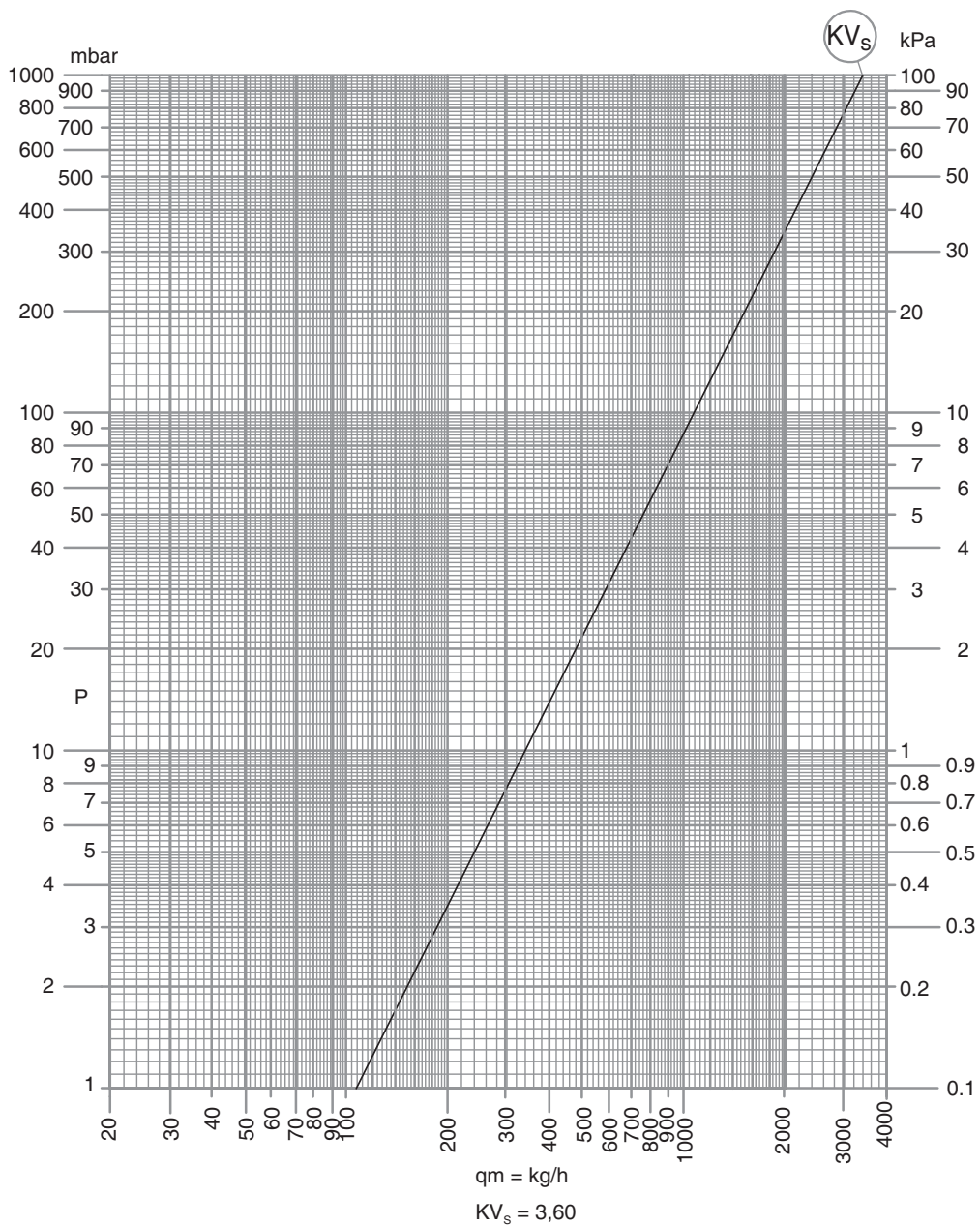

7.7 Way valve with thermo-electric head deviator valve kit

Consists of a 3-way deviator valve with thermo-electric head and a lockshield, fitted with micrometric adjustment, capable of balancing the system load losses).

The kit contains the insulation to be mounted on the valve and on the lockshield.

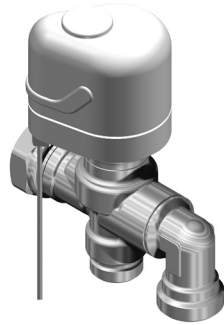

Diagram of load losses of deviator valve, present in kit, in completely open position.

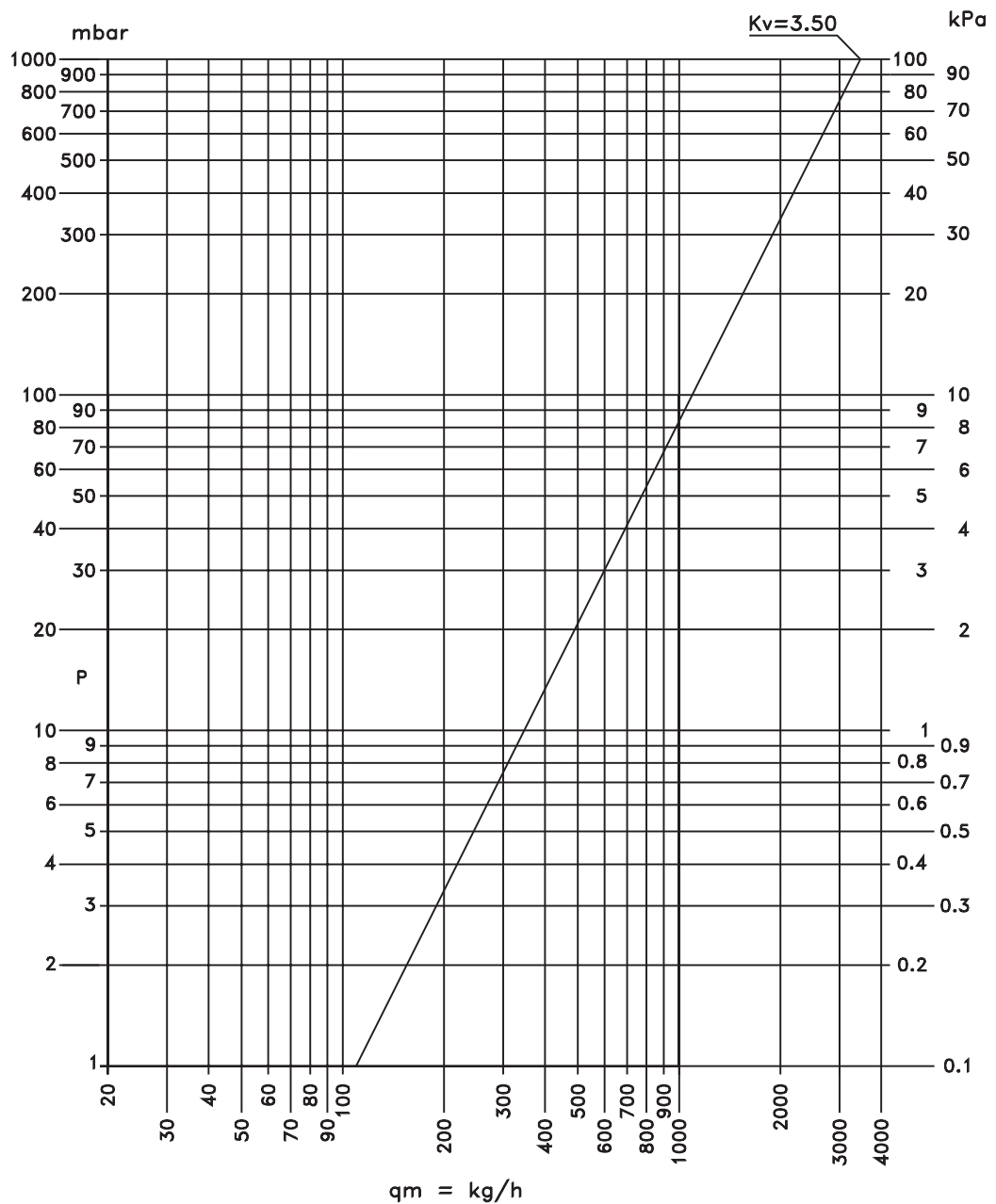
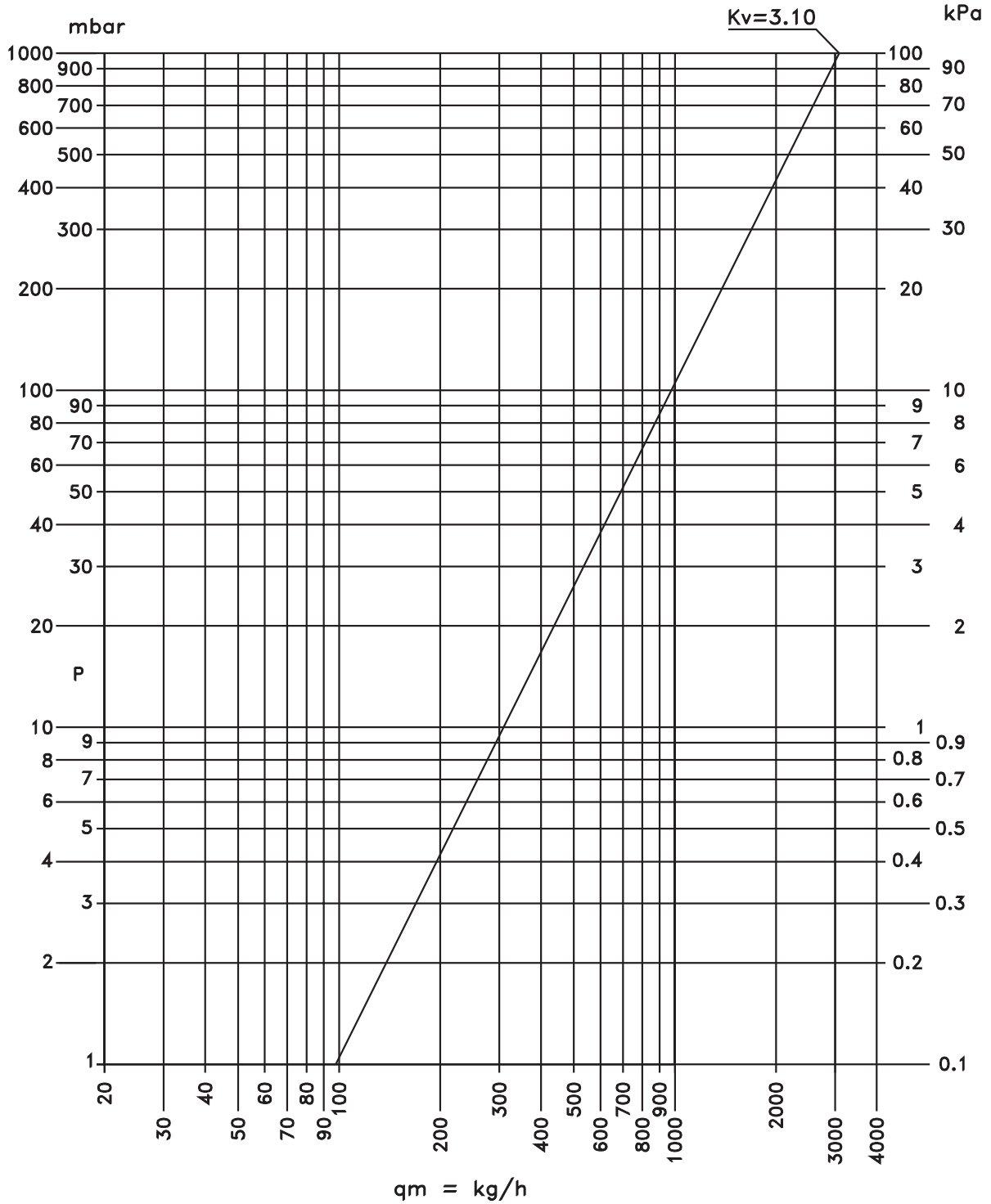

Diagram of load losses of deviator valve, present in kit, in completely closed position.



7.8 Connections

The choice and sizing of the hydraulic lines must be made by an expert who must operate according to the rules of good technique and the laws in force.

To make the connections:

- position the hydraulic lines
- tighten the connections using the "spanner and counter spanner" method
- check for any leaks of liquid
- coat the connections with insulating material

The hydraulic lines and joints must be thermally insulated.

Avoid partially insulating the pipes.

Do not over-tighten to avoid damaging the insulation.

Use hemp and green paste to seal the threaded connections; the use of Teflon is advised when there is anti-freeze in the hydraulic circuit.

A	Eurokonus adapter
B	Spanner and counter spanner

C	Coat the connections with insulating material
----------	---

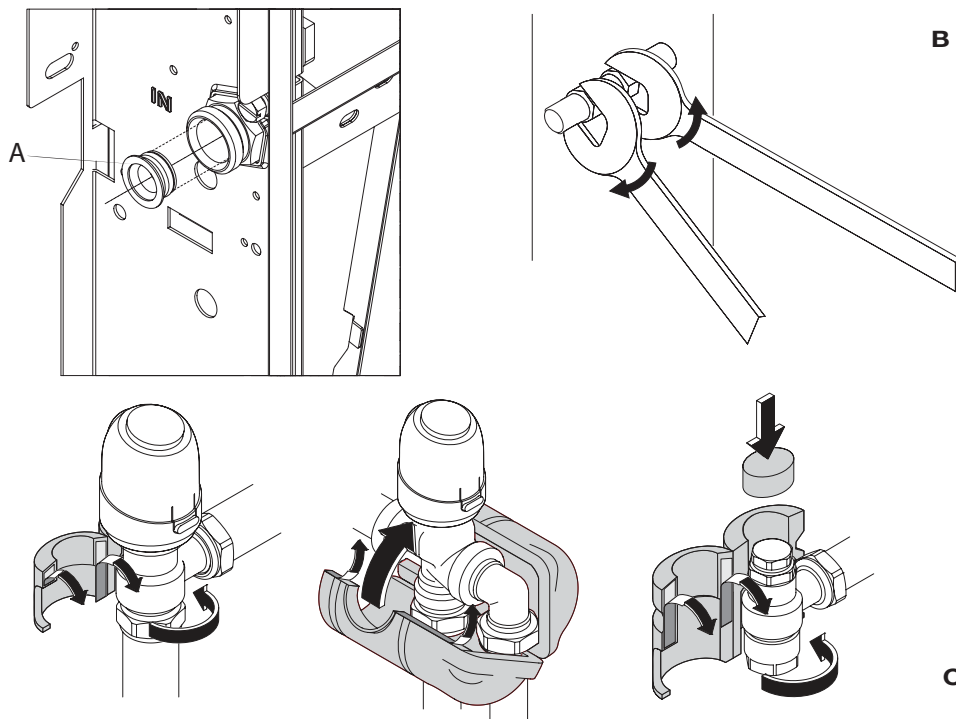

7.9 2-way valve unit kit

Consists of an automatic valve with thermo-electric head and a lockshield, fitted with micrometric adjustment, capable of balancing the system load losses.

- Remove the side panel as indicated in paragraph Side opening.
- Assemble the components as indicated in figure
- Apply the supplied insulation.

1	thermo-electric head (n.1)
2	lockshield (n.1)
3	2-way valve (n.1)

The kit contains the insulation to be mounted on the valve and on the lockshield.

⚠ When the hydraulic components have been mounted, connect the thermo-electric head connectors with the wiring connectors on the machine.

X	thermo-electric head connectors
Y	wiring connectors

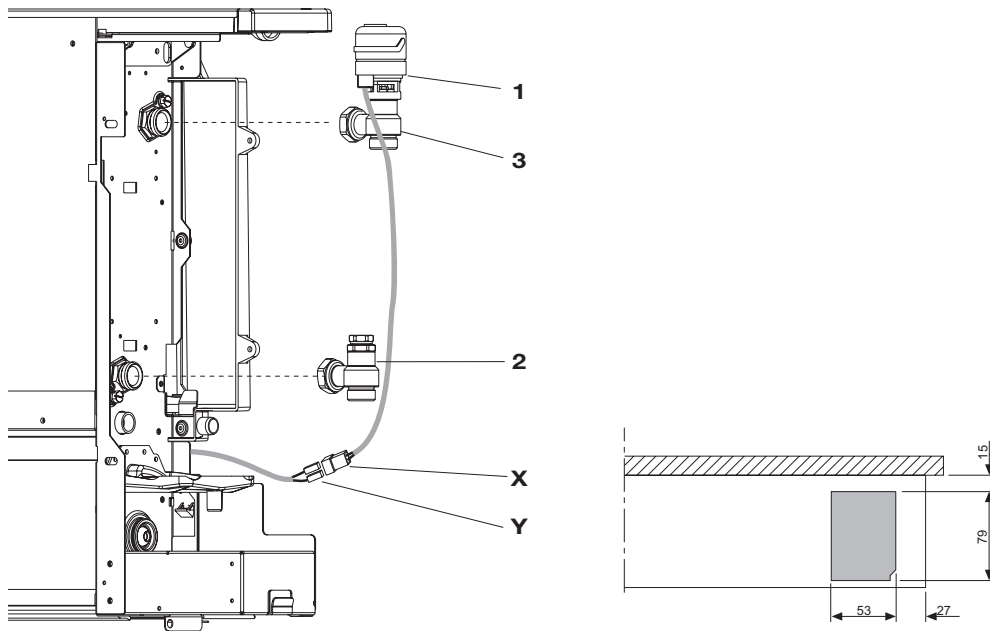

7.10 3-way valve unit kit

Consists of an automatic 3-way diverter valve with thermo-electric head and a lockshield, fitted with micrometric adjustment, capable of balancing the system load losses. The kit contains the insulation to be mounted on the valve and on the lockshield.

- Remove the side panel as indicated in paragraph Side opening.

- Assemble the components as indicated in figure
- Apply the supplied insulation.

⚠ When the hydraulic components have been mounted, connect the thermo-electric head connectors with the wiring connectors on the machine.

Floor mounted version

1	thermo-electric head (n.1)
2	lockshield (n.1)
3	3-way valve (n.1)
4	outlet union (n.1)

5	1/2" flexible tube 230 (n.1)
X	thermo-electric head connectors
Y	wiring connectors

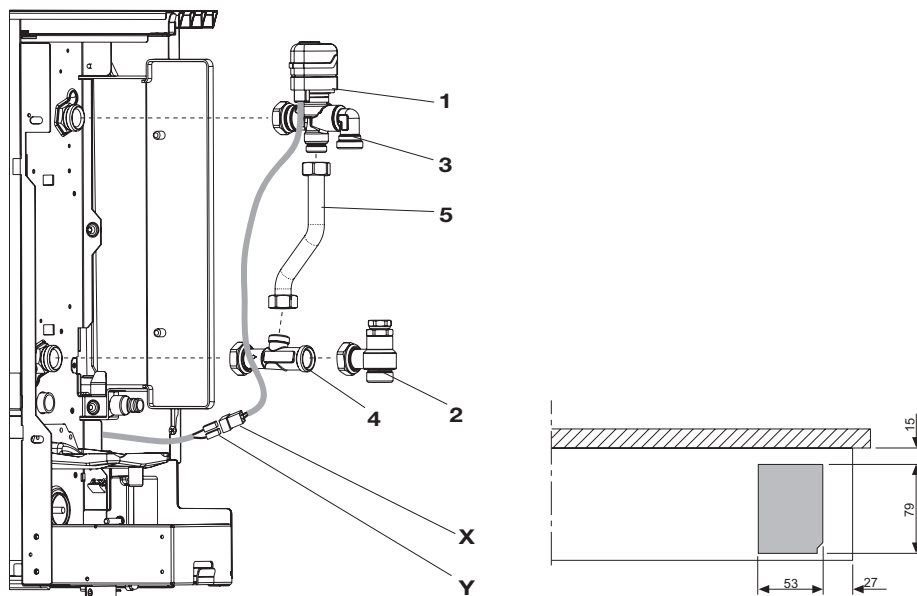

8. COOLER-CONVECTOR, DEUMIDIFICATION

HEATING,

COOLING

AND

8.1 Fundamental safety rules

- ⊖ Do not allow children or unassisted disabled people to use the unit.
- ⊖ Do not open the access covers and carry out technical or cleaning activities before disconnecting the unit from the power grid by positioning the system's main switch in the "off" position.
- ⊖ It is forbidden to modify the safety or regulation devices without the authorisation and directions of the manufacturer.
- ⊖ Do not stand, sit and/or place objects on the unit.
- ⊖ Do not pull, detach or twist the electrical wires coming out of the unit, even when the unit is disconnected from the power grid.
- ⊖ Do not spray or throw water directly on the unit.
- ⊖ Do not dispose of, abandon or leave the potentially hazardous packaging materials within the reach of children.
- ⊖ It is strictly forbidden to touch any moving parts, interfere with them or introduce pointed objects through the grids.
- ⊖ Do not touch the unit while barefoot and/or partially wet.

8.2 Description

The device is a terminal facility that contains in a single device the best solution for the heating, cooling and dehumidification. Allows you to achieve energy efficiency very high for the possibility of being coupled with generators of heat at low temperature such as: heat pumps, condensing boilers integrated systems with solar collectors. Thanks to a sophisticated temperature controller, the device, providing excellent thermal comfort in every season. Heats and cools very rapidly and once it reaches the desired temperature, keeps it very precisely in utter silence. In heating mode, the device develops

an effective natural convective effect (similar to that of a radiator) which greatly reduces the need to activate the ventilation. Its harmonious design and exceptionally low depth of only 15 cm make it integrated into any type of environment for all furnishing needs.

- ⊖ The unit combined with different control panels on board have the factory settings with parameters for maximum speed to 1700 rpm. To modify these parameters follow the procedures contained in instructions supplied with the control panel.

8.3 Identification

Technical Tag

⚠ The technical tag shows all technical and performance data of the unit. Should the tag get lost, please ask for a duplicate tag from the Technical Service.

⚠ Any tampering with, the removal or the lack of the Technical Tag or of any other element whose absence prevents certain identification of the product makes it more difficult to install and maintain the product.

Main components:

A	Structure
B	Heat exchanger
D	Fan unit
E	Electric motor controlled by INVERTER
F	Supply air grille reversible
H	Drain pan
I	Back structural
L	Front cover
M	Removable side panels
N	Air filter
P	R version micro-fan

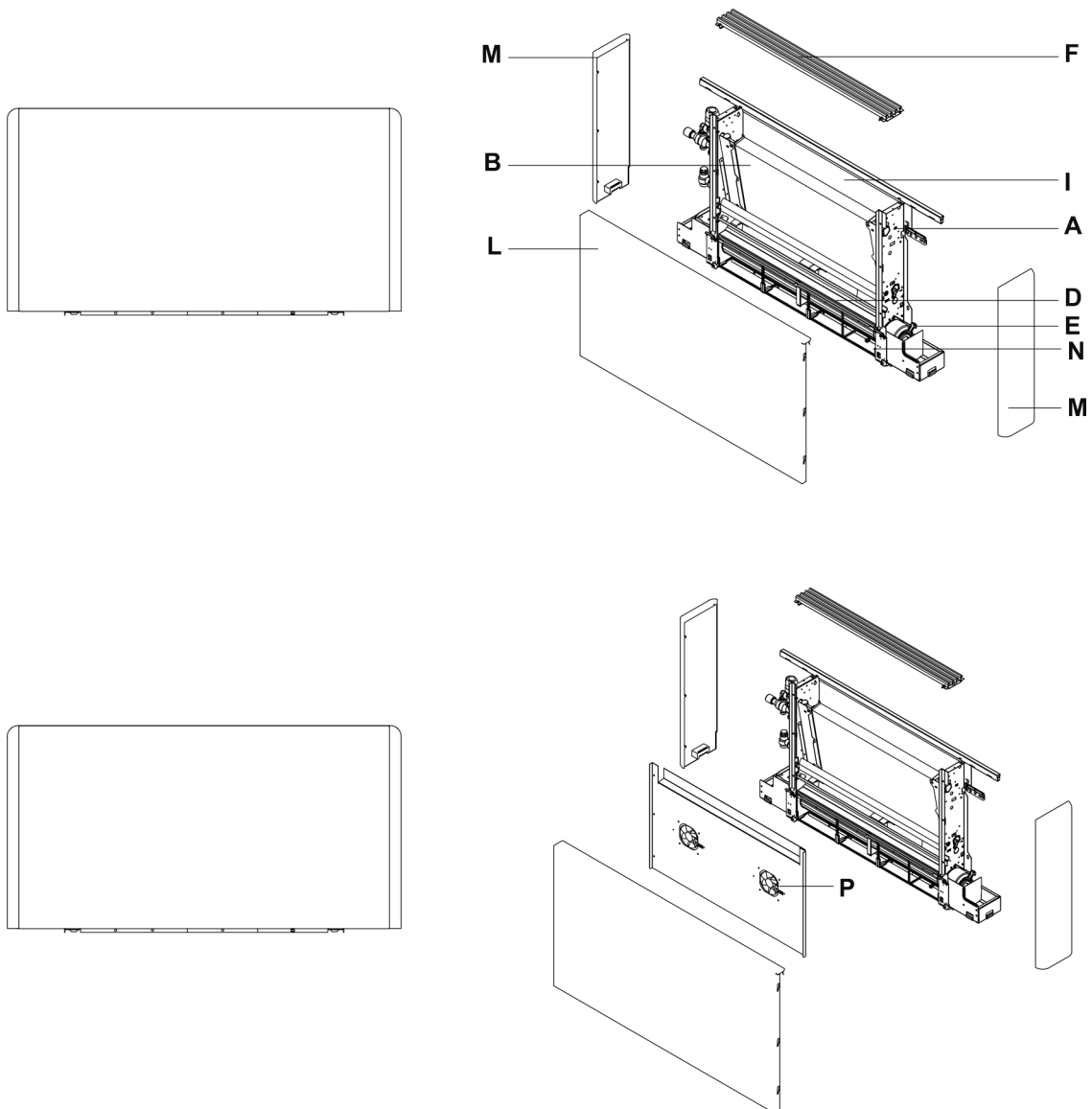

8.4 Charts of Water flow - Pressure drop

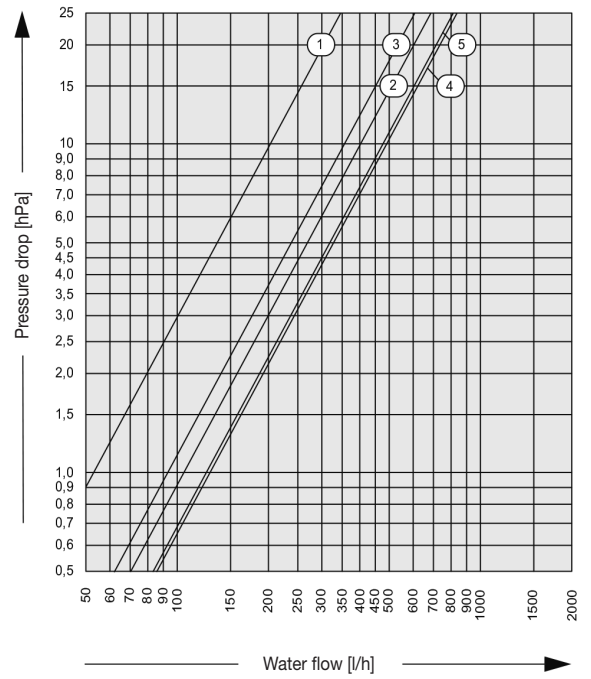
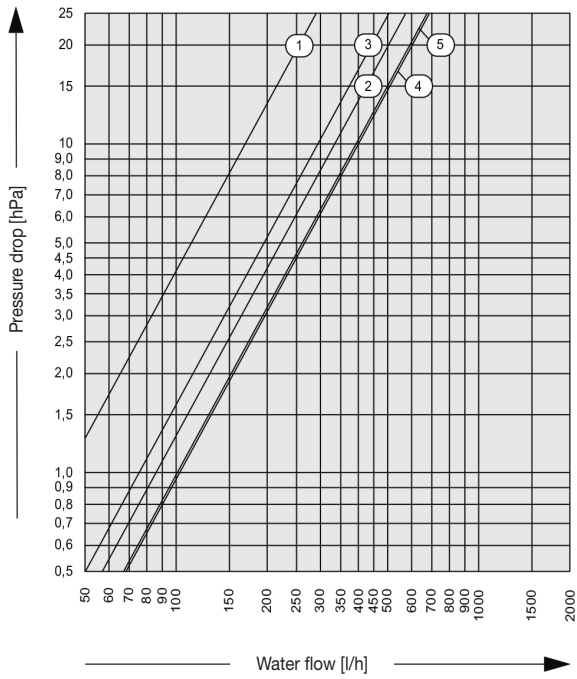

8.5 Dimensions

Size		23	45	64	76	94
Dimensions						
A	mm			140		
B	mm			80		
C	mm			20		
D	mm			20		
E	mm			400		
Dimensions: Tivano - Tivano R						
L	mm	723	923	1123	1323	1523
Net weight						
	Kg	17	20	23	26	29

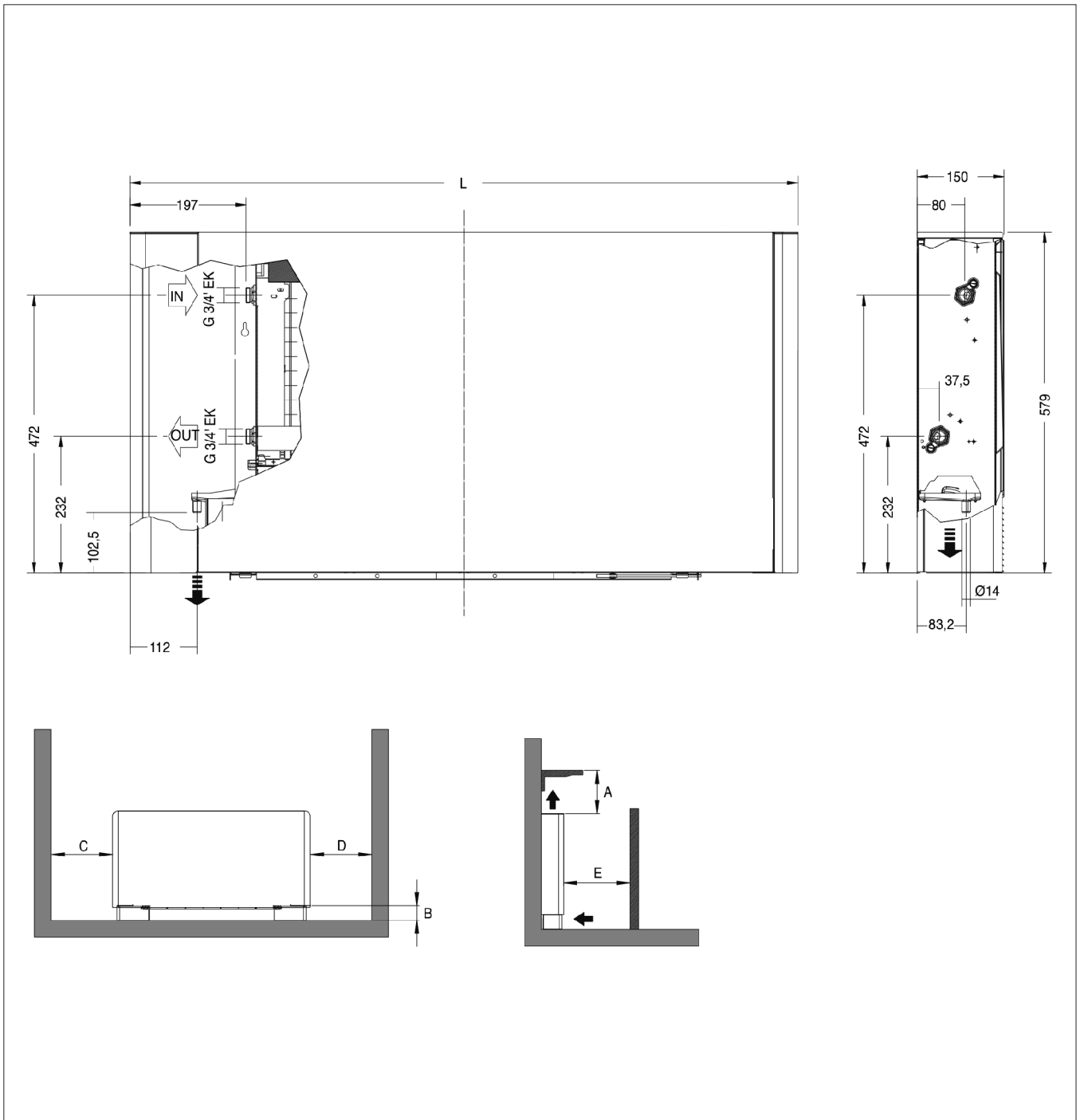

8.6 Product delivery

Preliminary instructions

⚠ We suggest to take the equipment out of its packaging only when it has been placed in position at the installation point.

⚠ Carefully remove any adhesive strips positioned on the unit.

Scope of supply

Also supplied:

Do not dispose of, abandon or leave the potentially hazardous packaging materials within the reach of children.

8.7 Handling and transportation

⚠ The unit must be handled by skilled technicians, appropriately equipped and with the appropriate tools to manage the unit's weight in compliance with the accident prevention regulations.

8.8 Access to inner parts

- Lift it up the side panels.
- Move orizzontally to remove.

A	Left panel
B	Right panel

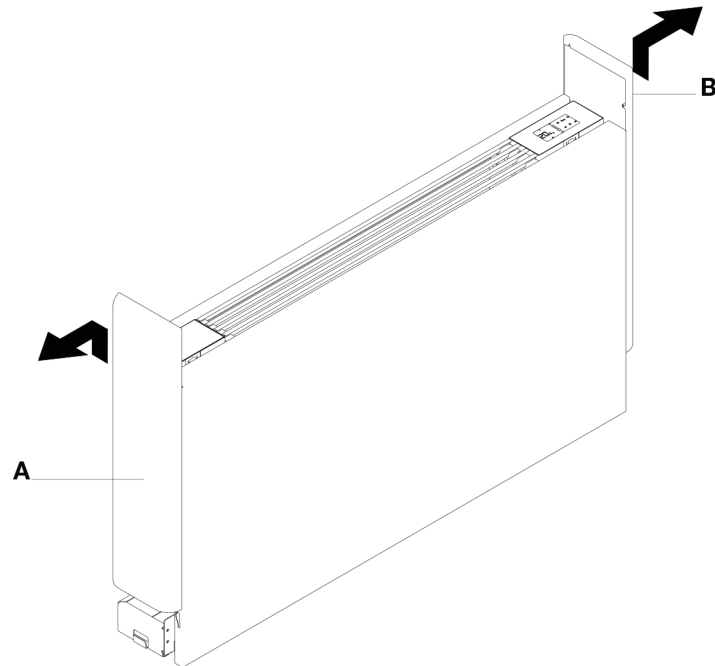

8.9 Installation

Preliminary instructions

⚠ The place of installation must be determined by the system's designer or by an expert in the field and must take into account the technical requirements and the current standards and legislation.

⚠ Before starting installation, decide the placement of the unit taking into account the minimum required distances.

⚠ Detailed information on the unit (measurements, dimensions, fastenings, required distances, etc.) are shown in the "Technical Data" chapter.

⚠ The unit is designed for vertical installation on the floor.

⚠ In order to guarantee the correct operation of the equipment, the units must be installed so that the air outlet and inlet shall remain unobstructed.

⚠ In case of concealed installation a detachable section cut into the suspended ceiling is required in order to access the unit.

⚠ The unit must be mounted so as to guarantee the circulation of the processed air throughout the whole environment.

⚠ Check that:

- The support wall can support the weight of the unit.
- The wall section does not include bearing elements, pipes or electric lines.

⚠ We suggest to avoid:

- Sunbeams and nearness to heat sources.
- Damp environments and locations where the unit might come into contact with water.
- Environment containing oil vapours
- Environment contaminated by high frequencies

⚠ The following descriptions of the various phases of assembly and the related drawings refer to a version of the machine with connections on the left.

8.10 Minimum installation distances

Figure indicates the minimum mounting distances between the wall-mounted cooler-convactor and furniture present in the room.

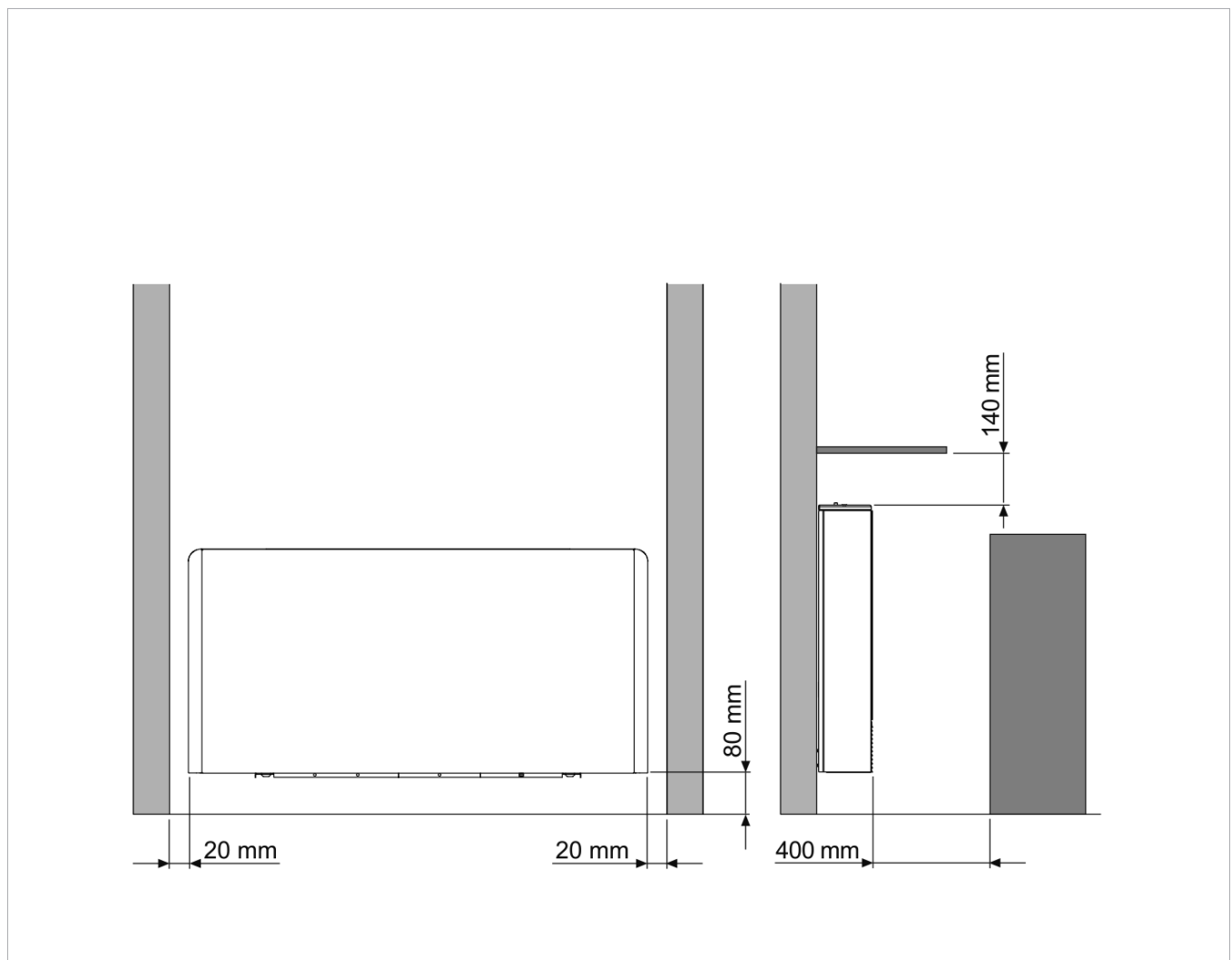

8.11 Vertically mounted

⚠ When mounting on the floor with support feet, refer to the individual instructions leaflets supplied and the relative manual for the mounting of the feet.

- Using the paper template, trace the position of the two fixing brackets on the wall.
- Use a suitable drill to make the holes with and insert the toggle bolts (2 for each bracket); fix the two brackets. Do not over-tighten the screws so that the brackets can be adjusted with a spirit level.

- Fully tighten the four screws to block the two brackets.
- Check the stability by manually moving the brackets to the right and to the left, up and down.
- Mount the unit, checking that it fits correctly onto the brackets and checking that it is stable.

A Toggle bolts

B Brackets

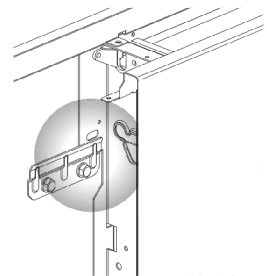
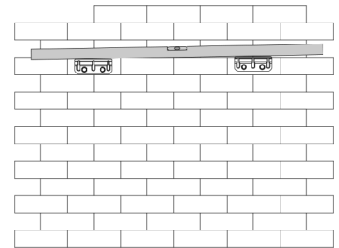
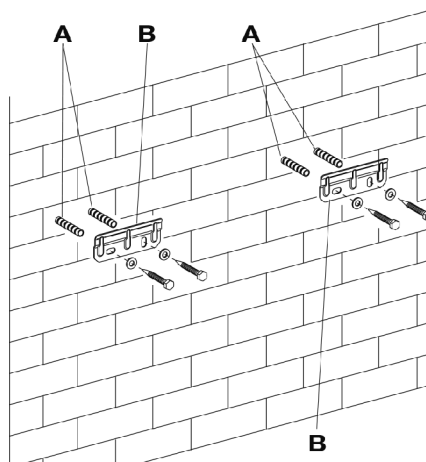
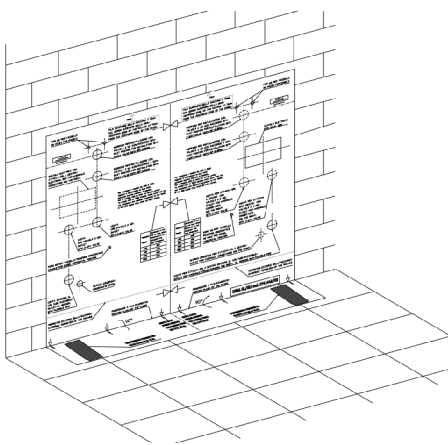

8.12 Hydraulic connections

Size		23	45	64	76	94
Pipes						
Diameter	mm	12	14	16	18	20

The choice and sizing of the hydraulic lines must be made by an expert who must operate according to the rules of good technique and the laws in force.

To make the connections:

- Position the hydraulic lines
- Tighten the connections using the “spanner and counter spanner” method
- Check for any leaks of liquid
- Coat the connections with insulating material.

Accompanying this unit there are two adapters to transform

the 3/4” Eurokonus connections in 3/4” BSP. In this case use hemp and green paste or similar to seal the threaded connections; the use of Teflon is advised when there is anti-freeze in the hydraulic circuit.

⚠ The hydraulic lines and joints must be thermally insulated.

⚠ Avoid partially insulating the pipes.

⚠ Do not over-tighten to avoid damaging the insulation.

A Eurokonus adapter

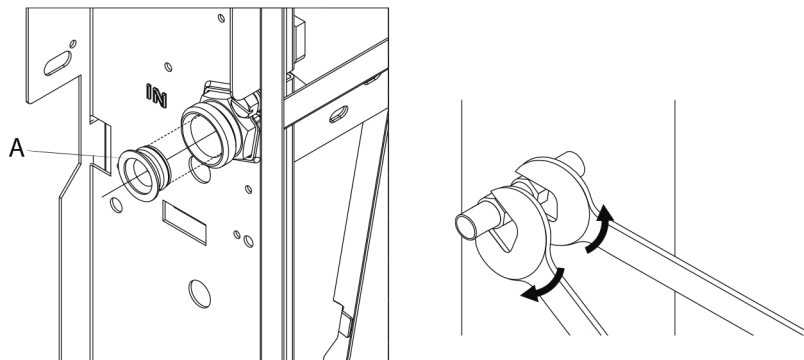

8.13 Condensation discharge

The condensation discharge network must be suitably sized and the pipeline positioned so that it keeps a constant inclination, never less than 1%.

In the vertical installation, the discharge pipe (16 mm diameter) is connected directly to the discharge tray, positioned at the bottom of the side shoulder underneath the hydraulic fixtures.

- If possible, make the condensation liquid flow directly in a gutter or a "rainwaters" discharge.
- When discharging directly into the main drains, it is advisable to make a siphon to prevent bad smells returning up the pipe towards the room. The curve of the siphon must be lower than the condensation collection bowl.
- If the condensation needs to be discharged into a container, it must be open to the atmosphere and the tube must not be immersed in water to avoid problems of adhesiveness and counter-pressure that would interfere with the normal outflow.
- If there is a height difference that could interfere with the outflow of the condensation, a pump must be mounted:
- In a vertical installation mount the pump under the lateral drainage tray;

Such pumps are commonly found in commerce.

However, on completion of the installation it is advisable to check the correct outflow of the condensation liquid by slowly pouring about ½ l of water into the collection tray in about 5-10 minutes.

Mounting the condensation discharge pipe in the vertical version

Connect to the condensation collection tray discharge union a pipe for the outflow of the liquid blocking it adequately. Check that the drip-collector extension is present and correctly installed.

⚠ Make sure that the machine is installed perfectly level or with a slight inclination towards the condensation discharge;

⚠ Insulate carefully the inflow and outflow pipes up to the machine union to prevent any drops of condensation outside the same collection bowl;

⚠ Insulate the bowl condensation discharge pipe along all of its length.

A	Discharge fitting
B	Pipe for the flow of liquid

C	Extension drip
----------	----------------

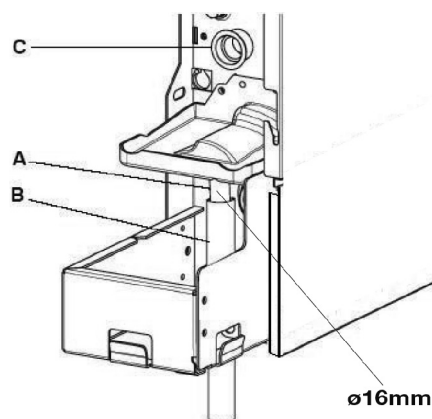

8.14 Electrical connections

Preliminary instructions

 Detailed information on the unit (measurements, dimensions, fastenings, required distances, etc.) are shown in the "Technical Data" chapter.

 The manufacturer waives all liability for damages caused by lack of grounding or departure from the electrical diagrams.

 Check that:

- The characteristics of the power supply network shall be appropriate for the unit's power requirements, taking into account also other equipment which might be operated in parallel.
- Electrical voltage shall be equal to the nominal value +/- 10%, with a maximum phase unbalance of 3%.

 Mandatory items:

- The use of an omnipolar magnetothermic switch, lockable line disconnecter, compliant with CEI-EN

standards (contacts open by at least 3 mm), with adequate disconnection power and differential protection in compliance with the electrical data table below, installed next to the unit.

- Ground the unit thoroughly.

 Do not use gas and water pipes to ground the unit.

Connection

 Make electrical connections according to the requirements set out in sections General Warnings and Fundamental Safety Rules by reference to the patterns present in the installation and accessories manuals.

 Before doing any work, make sure the power is switched off.

8.15 Filling the system

When starting up the system, make sure that the hydraulic unit lockshield is open. If there is no electric power and the thermo-valve has already been powered use the special cap to press the valve stopper to open it.

8.16 Evacuation of air when filling system

- Open all the system interception devices (manual or automatic);
 - Start the filling by slowly opening the system water filling tap;
 - For the installed in a vertical position, take a screwdriver and act on the highest breather of the battery.
 - When water starts coming out of the breather valves of the appliance, close them and continue filling until reaching the nominal value for the system.
- ⚠ Check the hydraulic seal of the gaskets.
- ⚠ It is advisable to repeat these operations after the appliance has been running for a few hours and periodically check the pressure of the system.

8.17 First commissioning

Preliminary instructions

Check that:

- All safety conditions have been fulfilled
- All connections have been made correctly
- The hydraulic test of the circuit and condensate discharge has been done successfully.
- Grounding has been done correctly.
- All connections have been fastened well.

Start

- Position the unit's main switch in the "on" position.
 - Turn the unit on with the control.
 - Check performance in the various modes.
- ⚠ Please consult the instructions for information on how to use the control.

A Venting of the battery

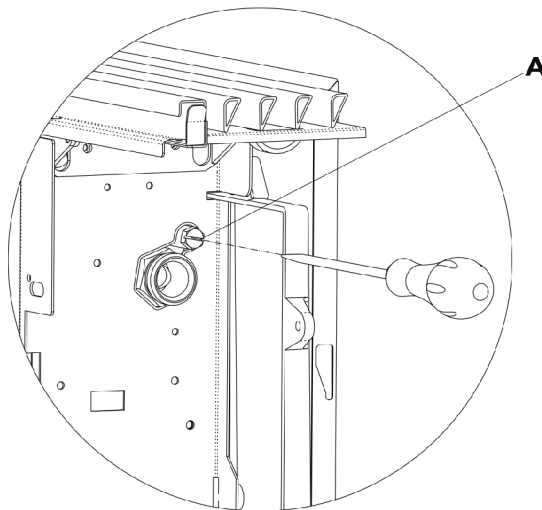

9. MODULATING TEMPERATURE CONTROLLER KIT

9.1 SMART TOUCH electronic control panel

These controls make room temperature adjustment (with offset settable from the keyboard) completely autonomous through the AUTO, SILENT, NIGHT and MAX programmes by means of a probe located in the lower part of the device, ensuring anti-freeze safety even when set to stand-by. The control panel has a memory, so settings will not be lost if the appliance is switched off or in the power supply is cut.

⚠ After 20 seconds from the last action the panel brightness will be reduced for improved night-time comfort, and the room temperature will appear on the display. Press any key to restore maximum brightness. The 10 kΩ water temperature probe positioned in the device battery regulations the minimum level when heating (30°C) and the maximum level when cooling (20°C).

A	Display
B	Keys

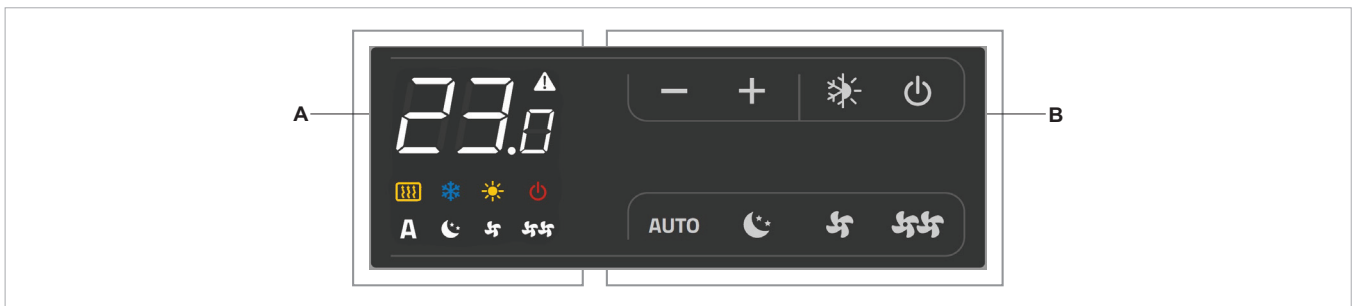

9.2 Display

Any statuses and alarms are also shown on the display by using 8 specific symbols:

A	Automatic operation
	Silent operation
	Maximum ventilation speed
	Night-time operation
	Heating on

	Cooling on
	Supervision on Flashing with presence switch CP closed.
	Alarm indicator (solid light)
	Panel off indicator
	Resistance active indicator

9.3 Key function

The various functions are set using 8 backlit keys:

	Temp + is for increasing the set temperature
	Temp - is for decreasing the set temperature
	Heating / Cooling: for changing the operation mode between heating and cooling
AUTO	Sets the regulation ventilation speed between a minimum and maximum value to an entirely automatic mode

	Night-time operation: limits ventilation speed to a contained level and the set temperature is adjusted automatically.
	Maximum speed operation: Allows for the maximum ventilation speed to be set
	ON/Stand-By: for activating the device or for putting it in stand-by.
	Silent: limits ventilation speed to a more contained value

9.4 General On Switch









In order to manage the device via the control panel, this must be connected to the mains electricity.
If a general switch is installed on the power line, this must

also be switched on.





- Turn the device on by activating the general switch.

9.5 Activation

- To activate the device

Key	Operation	Display
	Press the ON Stand-by key	From off to on
AUTO   	Select one of the 4 operating modes by pressing the relative key.	  A  

9.6 Heating/cooling operation modes setting

Key	Operation	Display
	Keep the Heating / Cooling key pressed for approx. 2 seconds to change the mode between heating and cooling, which is indicated by the 2 symbols that appear if heating or cooling is active.	 
	When heating, the symbol displays when the set point is higher than ambient temperature, both are off when the set point is lower.	
	When cooling, the symbol displays when the set point is lower than ambient temperature, both are off when the set point is higher.	

One of the two symbols flashing means that the water temperature (hot or cold) is not sufficient, and stops the fan until the temperature reaches a level suitable for reaching the required temperature.
If after switching the power on the board detects the

H2 probe, start-up occurs in normal conditions with the minimum and maximum thresholds.

The board also has a function when there is no H2 probe, in such cases the fan stop thresholds are ignored.



9.7 Stand By

Key	Operation	Display
	Press and hold the ON Stand-By key for approx. 2 seconds. No illuminated signals on the display at all means that the system is in stand-by (no operation).	Off

When the control is in this operating mode, anti freezing is in any case guaranteed. If the ambient temperature drops

below 5°C, the solenoid valves on the hot water output and the boilers are opened.

9.8 Temperature selection

Key	Operation	Display
	Set the required room temperature using the two increase/decrease keys to set the temperature value on the 3-digit display.	20.5
		

The adjustment range is from 16 to 28°C in intervals of 0.5°C, but out-of-range values are also accepted, from 5°C to 40°C (unless in auto mode). Only set these values for brief periods, and then set a

intermediate value.

The controller is very precise - set it to the required value and wait for the controller to regulate itself according to the actual room temperature detected.



9.9 Automatic operation

Key	Operation	Display
AUTO	Press and hold the AUTO key. The function being activated is indicated by the relevant symbol appearing on the display.	A

Ventilation speed adjustment is carried out automatically between the minimum and maximum values, according to



the distance of the actual room temperature from the set point, according to a PI-type algorithm.

9.10 Silent operation

Key	Operation	Display
	Press and hold the Silent key. The function being activated is indicated by the relevant symbol appearing on the display.	

Ventilation speed is limited to a contained maximum value.

9.11 Night-time operation

Key	Operation	Display
	Press and hold the Night-time operation key. The function being activated is indicated by the relevant symbol appearing on the display.	



By selecting this mode, ventilation speed is limited to a very contained level and the set temperature is adjusted automatically, as follows:

- decreases by 1°C after one hour and by another

degree after two hours in heating mode;

- increases by 1°C after one hour and by another degree after two hours in cooling mode;

9.12 Operation at maximum ventilation speed



Key	Operation	Display
	Press and hold the Max Operation key. The function being activated is indicated by the relevant symbol appearing on the display.	

In this operation mode, the maximum possible power level is activated whether heating or cooling.

Once the desired room temperature is reached, we

recommend selecting one of the other 3 operation modes for increased comfort and sound levels.



9.13 Key lock

Key	Operation	Display
	By pressing both the + and - keys for 3 seconds, all keys are locked locally, and this is indicated by "bL" appearing on the display. All actions are disabled to the user and whenever any key is pressed, "bL" will appear. To unlock the keys, repeat the sequence.	
		

9.14 Reduce brightness to minimum

After 20 seconds from the last action, the panel brightness will be reduced for improved night-time comfort, and the room temperature will appear on the display.

If this brightness is still disturbing, the display can be switched off completely.

Key	Operation	Display
	With the display off, press and hold the + key for 5 seconds until "01" is displayed. Use the - key to change the value to 00 and wait 20 seconds to check the setting has been accepted.	

9.15 Deactivation

Key	Operation	Display
	Press and hold the ON Stand-By key for approx. 2 seconds. No illuminated signals on the display at all means that the system is in stand-by (no operation).	Off

The controller also ensures anti freezing when in stand-by.



9.16 Room temperature probe regulation offset

As the detection probe is towards the bottom of the device, the temperature detected may at times differ from the actual room temperature.

By using this function, the value displayed can be adjusted

in a range from -9/+12 K in intervals of 0.1°C.

Use this adjustment with care, and only after having actually detected a discrepancy compared with the actual room temperature using a reliable device!

Key	Operation	Display
	With the display off, press and hold the - key for 5 seconds to access the menu which allows adjustment (using the + and - keys) of the AIR probe offset displayed, from -9 to +12 K in 0.1 K intervals. After 20 seconds from the last action, the panel switches off and the setting is stored.	

9.17 Switching off for long periods





When switching off for a season or for holidays, proceed as follows:

- Deactivate the device

- Turn the general unit switch to off.

-  The antifreeze function is not active.

9.18 Error signals

Error	Display
Faulty room temperature (AIR) probe	 E1
Problem with fan motor (e.g. blockage caused by foreign objects, faulty rotation sensor).	 E2
Water temperature probe fault for 2-tube versions (H2). <u>In this case, ensure that the probe installed is 10 kΩ.</u>	 E3
Engaging of grill microswitch S1 due to filter cleaning operation	 Gr

10. 4-SPEED TEMPERATURE CONTROLLER KIT

10.1 LCD electronic control panel

The controller makes the regulation of room temperature entirely automatic using the set point setting which can be adjusted between 5°C and 40°C, to one of the 4 speeds and the summer/winter setting.

As it is connected to the water temperature probe, in the battery it has the function of detecting the minimum temperature in winter (30°C) and maximum temperature in summer (20°C).

The control panel has a memory, so settings will not be lost if the appliance is switched off or in the power supply is cut.

⚠ After 20 seconds from the last action, the panel brightness will be reduced for improved night-time comfort, and the room temperature will appear on the display. Press any key to restore maximum brightness.

A	Display
B	Keys and LEDs

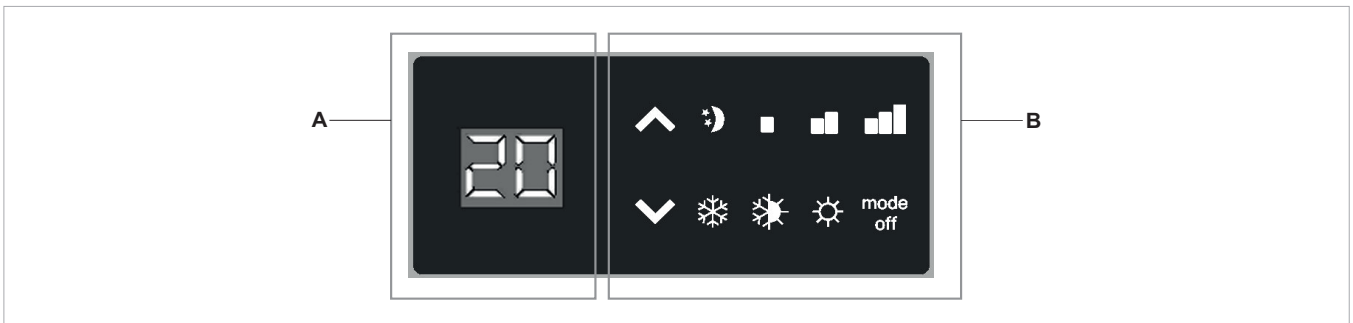

10.2 LED indications

The 6 LEDs display the operational states:

	Green symbol minimum speed
	Green symbol medium speed
	Green symbol maximum speed

	Green symbol Super silent function
	Red symbol heating
	Blue symbol cooling

10.3 Key function

The various functions are set using 4 keys:

	Temp + is for increasing the set temperature
	Temp - is for increasing the set temperature

	Heating / Cooling: for changing the operation mode between heating and cooling (2 seconds)
mode off	For activating the device, for selecting one of the 4 speeds or for placing in stand-by (2 seconds).

10.4 General On Switch

In order to manage the fan coil via the control panel, this must be connected to the mains electricity.

If a general switch is installed on the power line, this must

also be switched on.



- Turn the device on by activating the general switch.

10.5 Activation

To activate the device

Key	Operation	Display
mode off	Press the mode/off key	Off → On
mode off	Select one of the 4 operating speeds by pressing the relative mode/off key. When heating, the symbol displays when the set point is higher than ambient temperature, both are off when the set point is lower. When cooling, the symbol displays when the set point is lower than ambient temperature, both are off when the set point is higher.	

10.6 Heating/cooling operation modes setting

Key	Operation	Display
	Keep the Heating / Cooling key pressed for approx. 2 seconds to change the mode between heating and cooling, which is indicated by the 2 symbols that appear if heating or cooling is active.	



One of the two symbols flashing means that the water temperature (hot or cold) is not sufficient, and stops

the fan until the temperature reaches a level suitable for reaching the required temperature.

10.7 Stand By

Key	Operation	Display
mode off	Press and hold the mode/off key for approx. 2 seconds. No illuminated signals on the display at all means that the system is in stand-by (no operation).	On → Off

10.8 Temperature selection

Key	Operation	Display
	Set the required room temperature using the two increase/decrease keys to set the temperature value on the 2-digit display.	

The adjustment range is from 15 to 30°C in intervals of 1°C, but out-of-range values are also accepted, from 5°C (Lo) to 40°C (Hi).

Only set these values for brief periods, and then set a

intermediate value.

The controller is very precise - set it to the required value and wait for the controller to regulate itself according to the actual room temperature detected.

10.9 Ventilation speed regulation



Key	Operation	Display
mode off	Each time the mode/off button is pressed the fan speed moves between supersilent, minimum, medium and maximum. The function being activated is indicated by the relevant symbol appearing on the display.	

The super silent setting activates powerful dehumidifying when cooling and only radiation (with the fan off, and solenoid valve activated) when heating.

By setting the highest speed, the maximum possible power level is activated immediately whether heating or cooling.

Once the desired room temperature is reached, we recommend selecting one of the other 3 operation modes for increased comfort and sound levels.

10.10 Key lock

Key	Operation	Display
	When the increase and decrease keys are pressed simultaneously for 5 seconds, all keys are locally locked; this is indicated by bL appearing on the display.	
	All actions are disabled to the user and whenever any key is pressed, "bL" will appear. To unlock the keys, repeat the sequence.	

10.11 Reduce brightness to minimum

After 20 seconds from the last action, the panel brightness will be reduced for improved night-time comfort, and the room temperature will appear on the display. If this brightness is still deemed to be disturbing, the display can be switched off completely by pressing the Heating/

Cooling key for 20 seconds until the display shows **LO**. To return to normal minimum brightness, press the Heating/Cooling button for 20 seconds until the display shows **HI**.

10.12 Deactivation





Key	Operation	Display
mode off	Press and hold the mode/off key for approx. 2 seconds. No illuminated signals on the display at all means that the system is in stand-by (no operation).	Off → On

10.13 Switching off for long periods

When switching off for a season or for holidays, proceed as follows:

- Deactivate the device
- Turn the general unit switch to off.

10.14 Error signals

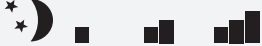
Error	Led	Display
Faulty room temperature (AIR) probe 6 LEDs flashing (alarm with automatic reset).		E1
Water temperature probe (H2) positioned in the main battery fault 2 LEDs flashing (possible manual reset)*.		E1
Problem with fan motor (e.g. blockage caused by foreign objects, faulty rotation sensor). 4 LEDs flashing simultaneously (alarm with automatic reset).		E1
Water demand (hot or cold) insufficient (above 20°C when cooling, below 30°C when heating). The LED of the selected function flashes and the fan is stopped until the water temperature reaches a suitable level to satisfy the demand.		
Grill protection micro switch tripped due to accidental opening of the grill or when filter cleaning is operating.		Gr

* If the board detects the water temperature probe on the device, it starts in normal conditions. If the probe is not

connected, operation can be confirmed without the probe by pressing the Heating/Cooling key for 5 seconds.

11. MAINTENANCE

Periodic maintenance is essential to keep the fan coil always efficient, safe and reliable over time. It must be

done at least once a year by a qualified service engineer Service.

11.1 Cleaning the outside

⚠ Before every cleaning and maintenance intervention, disconnect the appliance from the mains by switching off the master switch.

⚠ Wait until the parts have cooled down to avoid the risk of burns.

⚠ Do not use abrasive sponges or abrasive or corrosive detergents to avoid damaging the painted surfaces.

When necessary, clean the outer surfaces of the cooler-convector with a soft cloth damp cloth.

11.2 Cleaning air suction filter

After a period of continuous operation and in consideration of the concentration of impurities in the air, or when he intends to restart the plant after a period of inactivity, proceed as described. The periodicity is twice yearly in normally clean environment.

Extraction of filter cells

- Extract the filter, pulling it horizontally outwards.

A	Filter
B	Lower edge

C	Filter housing
----------	----------------

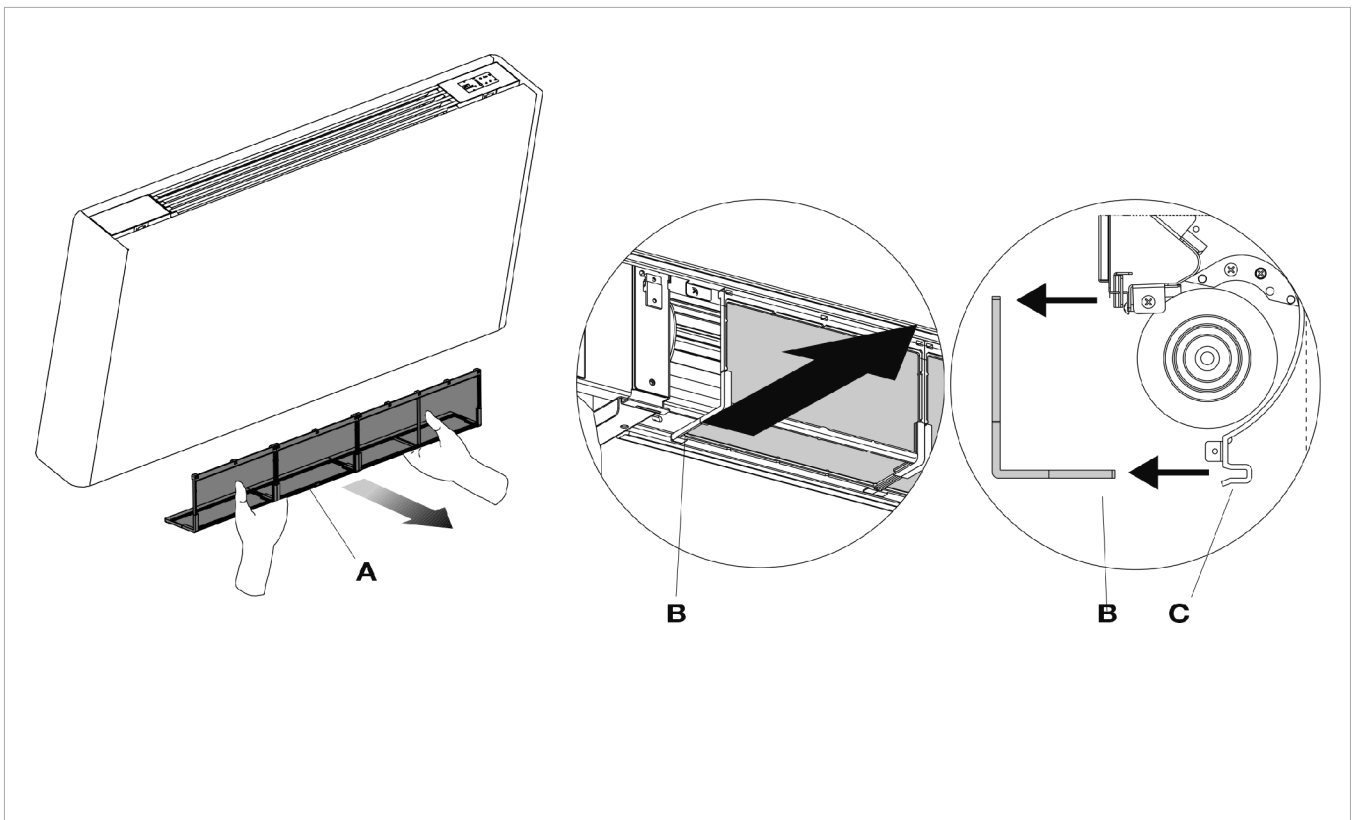

Cleaning filtering seats

- Suck up the powder with a vacuum cleaner
- Wash the filter with running water without using detergents or solvents, and leave to dry.
- Remount the filter on the cooler-convactor, taking care to insert the lower flap into its seat.

- ⊘ It is forbidden to use the unit without the net filters.
- ⚠ After finishing the cleaning of the filter, check that the panel is mounted correctly.

A	Filter
B	Lower edge

C	Filter housing
----------	----------------

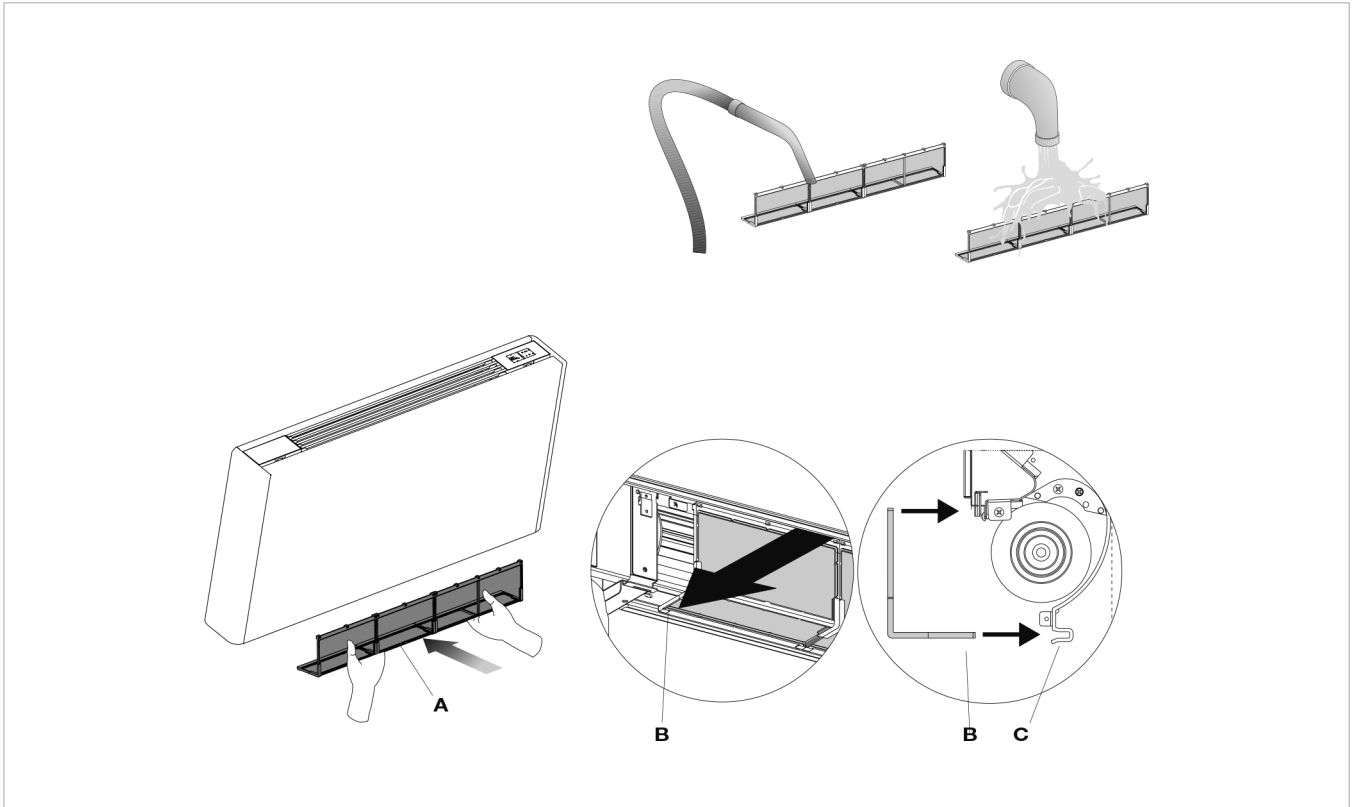

11.3 Energy saving tips

- Always keep the filters clean;
- When far possible, keep the doors and windows closed in the room being conditioned;
- Limit where possible the effect of direct sun rays in the rooms being conditioned (use curtains, shutters etc.)

12. TROUBLESHOOTING

⚠ In case of water leaks or anomalous functioning immediately cut off the power supply and close the water taps.

⚠ Should one of the following anomalies occur, contact Technical Service Assitant or an authorised qualified person, but do not intervene personally.

- The ventilation does not activate even if there is hot or cold water in the hydraulic circuit.
- The appliance leaks water during the heating function.
- The appliance leaks water only during the cooling function.
- The appliance makes an excessive noise.
- There are formations of dew on the front panel.

12.1 Table of anomalies and remedies

Out of warranty repairs and maintenance can be performed by Technical Service Assitant or by qualified personnel.

EFFECT	CAUSE	REMEDY
A delayed activation of the ventilation respect to the new temperature or function settings.	The circuit valve needs some time to open and as a result the hot or cold water takes time to circulate in the appliance.	Wait for 2 or 3 minutes to open the circuit valve.
The appliance does not activate the ventilation.	No hot or cold water in the system.	Check that the water boiler or cooler are functioning correctly.
The ventilation does not activate even if there is hot or cold water in the hydraulic circuit.	The hydraulic valve remains closed	Dismount the valve body and check if the water circulation is restored. Check the working efficiency of the valve by powering it separately with 230V. If it activates the problem could be the electronic control.
	The fan motor is blocked or burnt out.	Check the windings of the motor and the free rotation of the fan.
	The micro-switch that stops the ventilation when the filter grill is opened does not close correctly.	Check that by closing the grill the micro-switch contact is activated.
	The electrical connections are not correct.	Check the electrical connections.
The appliance leaks water during the heating function.	Leaks in the hydraulic connections of the system.	Check the leak and fully tighten the connections.
	Leaks in the valve unit.	Check the state of the gaskets.
There are formations of dew on the front panel.	Thermal insulation unstuck.	Check the correct positioning of the thermoacoustic insulation paying attention to that in the front above the finned battery.
There are drops of water on the air outlet grill.	In situations of high humidity (>60%) condensation could form, especially at the minimum ventilation speeds.	As soon as the humidity starts falling the phenomenon disappears. In any case the presence of a few drops of water in the appliance does not indicate a malfunction.
The appliance leaks water only during the cooling function.	The condensation bowl is blocked.	Slowly pour a bottle of water in the low part of the battery to check the drainage; if necessary, clean the bowl and/or increase the inclination of the drainage pipe.
	The condensation discharge does not need an inclination for correct drainage.	
	The connection pipes and the valve unit are not insulated well.	Check the insulation of the pipes.
The appliance makes a strange noise.	The fan touches the structure.	Check the clogging of filters and clean them if necessary.
	The fan is unbalanced.	The unbalancing causes excessive vibrations of the machine; replace the fan.
	Check the clogging of filters and clean them if necessary.	Clean the filters.



immergas.com

Immergas S.p.A.
42041 Brescello (RE) - Italy
Tel. 0522.689011
Fax 0522.680617

Certified company ISO 9001

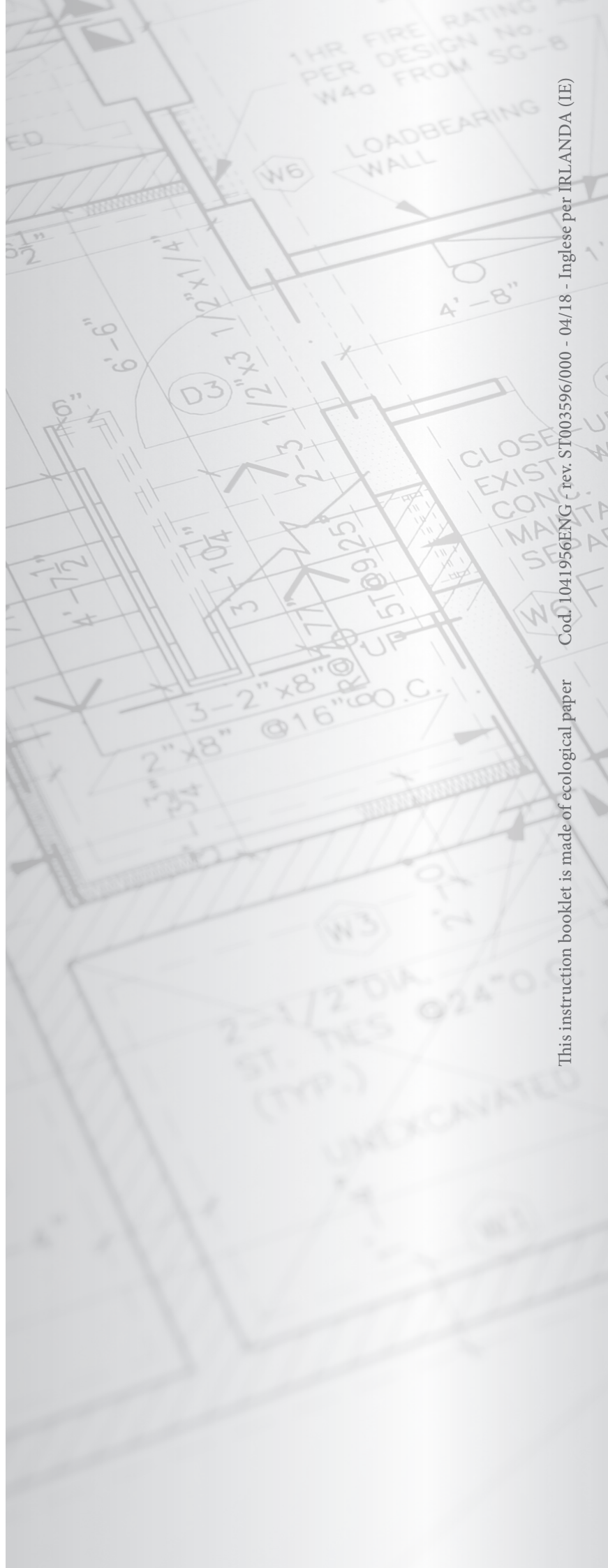

This instruction booklet is made of ecological paper

Cod. 1041956ENG - rev. ST003596/000 - 04/18 - Inglese per IRLANDA (IE)