



HEAT PUMPS

Monobloc solutions
Split type solutions
DHW solutions



HEAT PUMPS

HEAT PUMPS RANGE p. 3

MONOBLOC SOLUTIONS

AUDAX	p. 4
ADVANTAGES	p. 5
TECHNICAL DATA	p. 7
ACCESSORIES	p. 15

SPLIT TYPE SOLUTIONS

MAGIS PRO ErP	p. 16
ADVANTAGES	p. 17
TECHNICAL DATA	p. 18
ACCESSORIES	p. 25

MONOBLOC AND SPLIT TYPE SOLUTIONS RECESSED AND IN-HOUSE

TRIO V2/TRIO MONO V2	p. 26
ADVANTAGES	p. 27
BASE SYSTEM hydronic group + electric resistances for heating system and DHW	
+ AUDAX single-phase	p. 30
PRO SYSTEM hydronic group + electric resistances for heating system and DHW	
+ MAGIS PRO ERP	p. 32
COMBI SYSTEM hydronic group + combi gas boiler	
+ AUDAX single-phase	p. 34
PLUS SYSTEM hydronic group + only heating gas boiler + AUDAX single-phase	p. 36
ACCESSORIES	p. 42

DOMESTIC HOT WATER SOLUTIONS

RAPAX V2	p. 44
ADVANTAGES	p. 45
TECHNICAL DATA	p. 49
OPTION KITS	p. 51

ACCESSORIES

THERMOREGULATION	p. 52
OPTION KITS	p. 54

During the life of a product, performance is influenced by external factors, e.g. water hardness, atmospheric agents, system limiting, etc. The published data refers to new products correctly installed and used, in accordance with local regulations. N.B. we recommend regular periodic maintenance of the appliance.

Heat pumps range

Clean, safe energy for heating and cooling

Heat pumps are one of the best environment-friendly solutions for housing and office buildings climatization, both in the summer and in the winter period.

Immergas range is **dedicated to professionals who are looking for renewable-energies-powered solutions and integrated or hybrid systems so as to achieve high quality in indoor living conditions while complying the new EU regulation provisions.**

Immergas offers a wide range of solutions for heating, cooling (both mono-bloc and split type air-to-water heat pumps) and for domestic hot water production (heat pump water heater).

AUDAX is the name of our **new mono-bloc type, air-to-water units, suitable for any system solutions.** The range includes:

- **4 single-phase versions**, designed for home applications (6, 8, 12 or 16 kW)
- **3 three-phase version**, ideal for commercial facilities and offices (16, 18 or 21 kW)

MAGIS PRO ErP is the name of the new-born split-type, reversible air-to-water heat pump products, including dedicated external unit and an indoor hydronic unit, designed for housing solutions.

MAGIS PRO ErP can be also combined with electric resistance or a boiler for integrated systems.

RAPAX V2, heat pump water heater, can eliminate gas consumption for the production of domestic hot water. RAPAX V2 range is especially indicated to realize heating systems in single houses.



AUDAX

Air/water inverter heat pumps





WIDE RANGE OF PRODUCTS

Heat pumps are among the best solutions for environment-friendly climate control in homes and offices, summer and winter. The new Immergas range **is dedicated to professionals who are looking for systems with a strong use of renewable energy, integrated or hybrid systems that can provide great comfort while complying with regulations.**

AUDAX is the name of our **new self-contained air/water units**. Inverter technology modulates power, reduces power absorption and delivers high performance. It features a low-consumption circulator and a control panel that can be installed inside the home to control the unit remotely. AUDAX units are **suitable for any system solution** and can be combined with a separate storage tank for production of domestic hot water. Available in a range of powers from 6 to 21 kW. AUDAX 6, 8 and 12 could be connected to hydronic groups in order to realize recessed or in-house solutions TRIO V2/TRIO MONO V2 BASE (see page 30).

OPTIMAL OPERATION WITH FAN COIL AND RADIANT PANELS

With primary heating flow up to 60 °C, AUDAX units can work on low or medium temperature heating systems; in the summer cooling phase, they are ideal combined with a fan coil or radiant panels in association with a dehumidifier (see page 57).

FAST, EASY INSTALLATION

Featuring standard low-consumption circulator, expansion vessel, vibration dampers (option for 18 and 21 kW), 1" Y-shaped water filter and condensate drain fitting, our AUDAX heat pumps are also easy to install.

LOW ABSORPTION AND REDUCED NOISE LEVEL

Thanks to the use of inverter technology, power consumption is lower but heating and cooling performance remain high, especially during the in-between seasons when the heat load is reduced. Thanks to special technical features, sound emissions have also been reduced.





INTEGRATED SYSTEMS

Air-water heat pumps can be used as single components but also in an **integrated system** (such as boiler - solar thermal - heat pumps): these system solutions allow obtaining the maximum benefit from the different energy production systems.

For a correct functioning of the entire system, Immergas proposes an “intelligent” **system controller, able to determine the more convenient energy source in that moment** and therefore choose the appliance to be activated.

Moreover, the system controller allows:

- **maintaining the system performance high** in any circumstances
- **containing to the maximum the pollutant emissions** in the atmosphere
- **managing all the technological system** with a single device
- **controlling up to 4 AUDAX** in cascade

USER-FRIENDLY INTERFACE

The **standard control** panel not only displays operation diagnostics but also serves as weekly thermostat for **managing heating/cooling** with room temperature/humidity sensor in stand-alone applications. Easy connections by only 2 BUS cables and 2 power supply cables to connect it to AUDAX. The control panel doesn't need battery.

The control panel lets you:

- set room temperature (comfort/economy)
- set time and climate curve (in heating and cooling mode)
- view error codes for the heat pump



MAIN FEATURES AUDAX

- **"Free defrost" function** and hydrophilic coating on finned coil for improved water drainage (for versions up to 16 kW)
- **Inverter twin-rotary** (PAM and PWM) for all models
- **R410A refrigerant gas**
- **Variable speed fan** (modulating) with low turbulence blades and **Low loss Front grill**
- **Water/gas steel heat exchanger**
- Electronic **expansion valve**
- Electronic expansion valve and 4 way valve (for **reversible operation**)
- **Hot/cold** (reversible) **functioning**
- **Outdoor** installation
- **Expansion vessel as standard**
- **Low consumption system circulation pump**
- Heat pump setting and regulation (stand alone) through **control panel**, autodiagnostic with error code visualization
- Possible installation at **D.H.W. storage tank**
- **External probe as standard**



AUDAX 6 model

Technical characteristics	Unit of measurement	AUDAX 6	AUDAX 8	AUDAX 12	AUDAX 16 MONO
Code heat pump		3.027809	3.027810	3.027811	3.028238
Refrigerant quantity (R410A)*	g	1.100	1.600	2.800	2.800
Heating capacity (system water 35 °C)	kW	5,10	7,15	11,25	15,10
Heating capacity (system water 45 °C)	kW	4,85	6,80	11,30	13,40
Flow temperature range (CH)	°C	20 - 60	20 - 60	20 - 60	20 - 60
Outside air temperature range (CH)	°C	-20/35	-20/35	-20/35	-20/35
COP (system water 35 °C)		4,40	4,10	4,70	4,25
COP (system water 45 °C)		3,40	3,20	3,60	3,40
Heating min/max (system water 35 °C)	kW	0,82 / 5,27	1,36 / 8,77	3,73 / 13,67	3,73 / 15,92
Heating min/max (system water 45 °C)	kW	0,74 / 4,99	1,31 / 7,96	3,58 / 12,64	3,58 / 15,31
Cooling capacity (system water 18 °C)	kW	4,85	8,00	13,70	16,00
Cooling capacity (system water 7 °C)	kW	4,00	5,55	11,20	12,80
Flow temperature range (cooling)	°C	4 - 18	4 - 18	4 - 18	4 - 18
Outside air temperature range (cooling)	°C	10/46	0/46	0/46	0/46
EER (system water 18 °C)		4,35	4,00	4,60	4,10
EER (system water 7 °C)		3,10	3,10	3,40	3,10
Cooling min/max (system water 18 °C)	kW	1,40 / 5,50	0,97 / 8,72	4,74 / 18,46	4,74 / 18,46
Cooling min/max (system water 7 °C)	kW	0,89 / 4,09	0,50 / 5,95	2,61 / 13,70	2,61 / 13,70
System circuit max pressure	bar	3	3	3	3
Expansion vessel	l	2	2	3	3
Power supply	V - Hz	230 - 50	230 - 50	230 - 50	230 - 50
Maximum power absorbed	W	1.800	3.380	4.730	5.180
Nominal absorbed current	A	8	15	21	23
Electric protection index	IP	44	44	44	44
Weight	kg	57	69	115	115

* Hermetically sealed system.

Refer to the following conditions :

Environment	Heating [°C]	Cooling [°C]
T system water (R/M) - air (bs/bu)	30/35 - 7/6	23/18 - 35 (bs)
T system water (R/M) - air (bs/bu)	40/45 - 7/6	12/7 - 35 (bs)

AUDAX 6		
AUDAX 8		
AUDAX 12		
AUDAX 16 MONO		

Note: The labels are shown in the documentation accompanying the units as well as on the immergas.com website in each product's page.

Caratteristiche tecniche pompe di calore trifase	Unità di misura	AUDAX 16	AUDAX TOP 18 ErP	AUDAX TOP 21 ErP
Code heat pump		3.027812	3.025563	3.026940
Refrigerant quantity (R410A)*	g	3.000	8.000	8.000
Heating capacity (system water 35 °C)	kW	15,00	17,10	21,00
Heating capacity (system water 45 °C)	kW	13,50	16,16	19,97
Flow temperature range (CH)	°C	20 - 60	20 - 60	20 - 57
Outside air temperature range (CH)	°C	-20/35	- 20/30	- 20/30
COP (system water 35 °C)		4,35	4,10	4,10
COP (system water 45 °C)		3,50	3,40	3,30
Heating min/max (system water 35 °C)	kW	3,80 / 16,52	3,35 / 24,65	8,90 / 30,45
Heating min/max (system water 45 °C)	kW	3,65 / 15,88	3,20 / 23,15	8,48 / 29,59
Cooling capacity (system water 18 °C)	kW	17,00	19,38	25,80
Cooling capacity (system water 7 °C)	kW	13,00	14,88	18,58
Flow temperature range (cooling)	°C	4 - 18	5 - 18	5 - 18
Outside air temperature range (cooling)	°C	0/46	0/46	0/46
EER (system water 18 °C)		4,15	3,87	3,80
EER (system water 7 °C)		3,20	3,00	3,10
Cooling min/max (system water 18 °C)	kW	4,79 / 18,64	4,52 / 21,17	11,97 / 30,67
Cooling min/max (system water 7 °C)	kW	2,64 / 13,84	3,13 / 15,45	8,67 / 23,08
System circuit max pressure	bar	3	3	3
Expansion vessel	l	3	8	8
Power supply	V - Hz	400 - 50	400 - 50	400 - 50
Maximum power absorbed	W	10.320	10.800	12.400
Nominal absorbed current	A	15,2	16,7	19,1
Electric protection index	IP	44	44	44
Weight	kg	121	190,9	199,4

* Hermetically sealed system.

Refer to the following conditions :

Environment	Heating (°C)	Cooling (°C)
T system water (R/M) - air (bs/bu)	30/35 - 7/6	23/18 - 35 (bs)
T system water (R/M) - air (bs/bu)	40/45 - 7/6	12/7 - 35 (bs)

AUDAX 16		
AUDAX TOP 18 ErP		
AUDAX TOP 21 ErP		

Note: The labels are shown in the documentation accompanying the units as well as on the immergas.com website in each product's page.



AUDAX 6/8

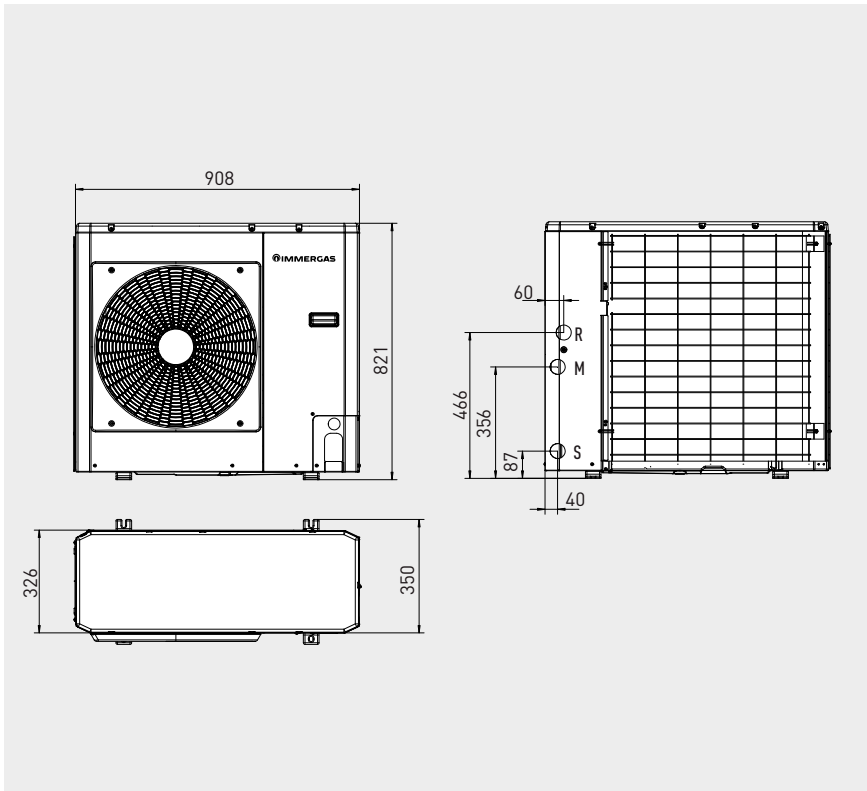

Key

- R Water inlet
- M Water outlet
- S Water drain

Connections

Water inlet	Water outlet	Drain
R	M	S
1" M	1" M	16 mm

AUDAX 12/16/16 MONO

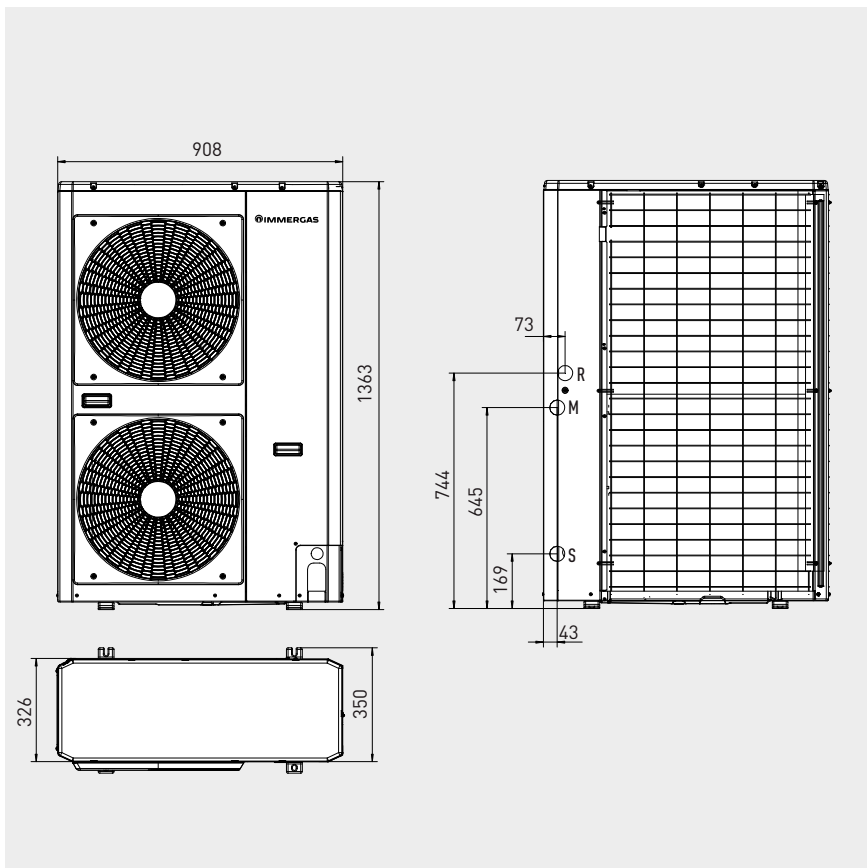

Key

- R Water inlet
- M Water outlet
- S Water drain

Connections

Water inlet	Water outlet	Drain
R	M	S
1" M	1" M	16 mm

AUDAX TOP 18/21 ErP

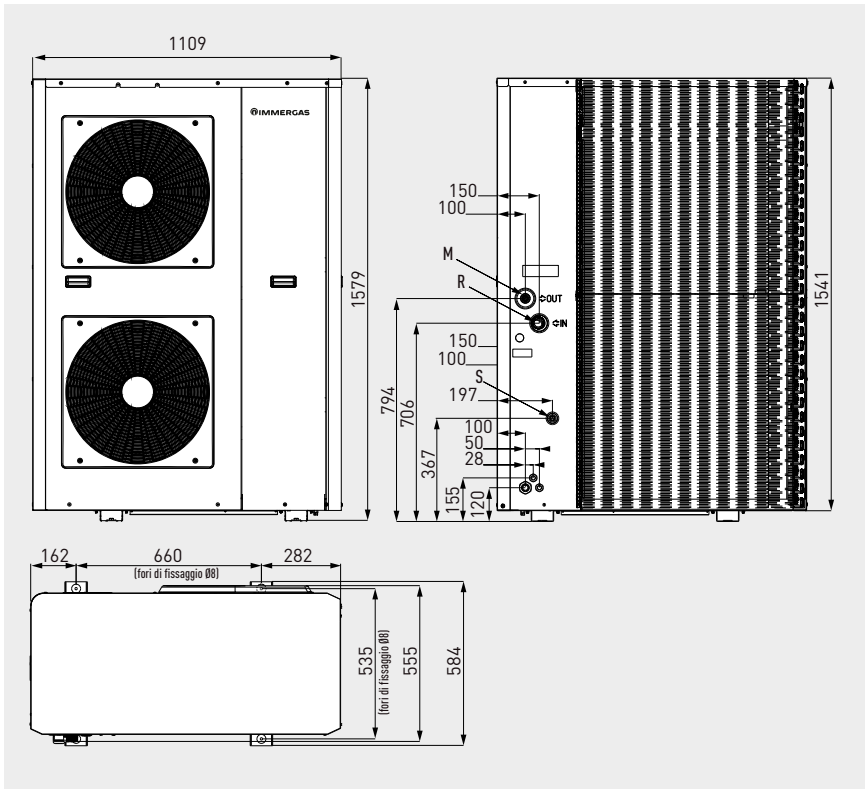

Key

- R Water inlet
- M Water outlet
- S Water drain

Connections

Water inlet	Water outlet	Drain
R	M	S
1 1/4" M*	1" M	16 mm

* 1" M Reduction standard supplied.



Flow rate/head graph
AUDAX 6

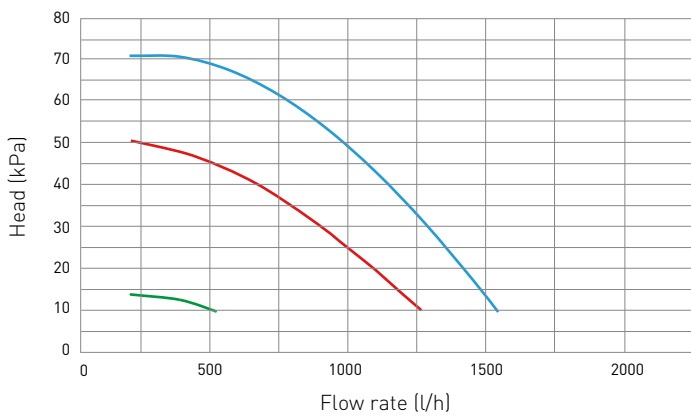

Available head in the system:

- minimum
- medium
- maximum

Flow rate/head graph
AUDAX 8

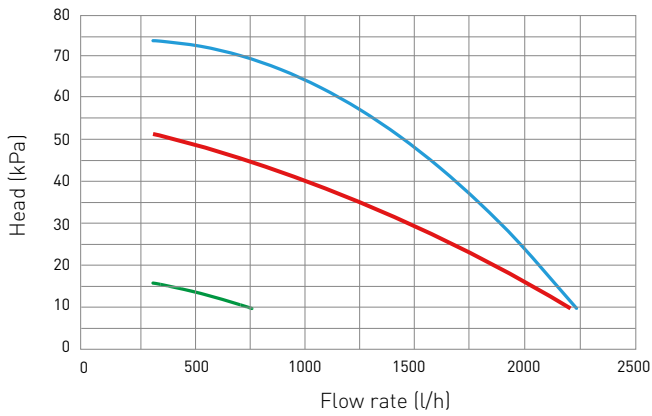

Flow rate/head graph
AUDAX 12/16/16 MONO

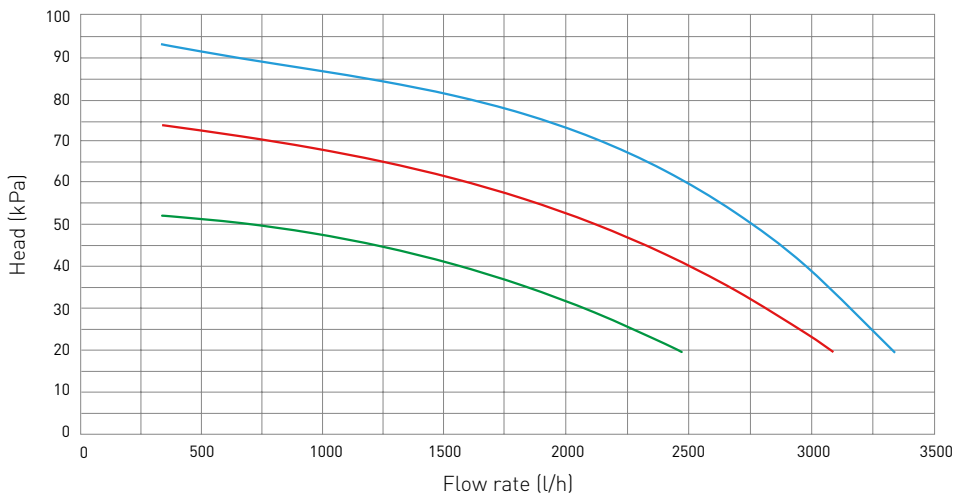

Flow rate/head graph
AUDAX TOP 18 ErP

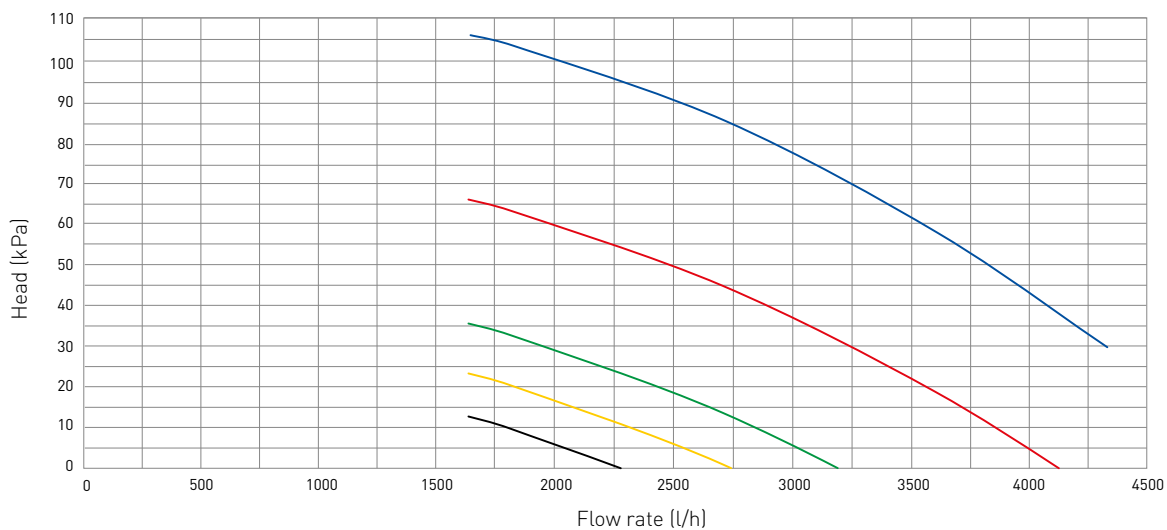

Flow rate/head graph
AUDAX TOP 21 ErP

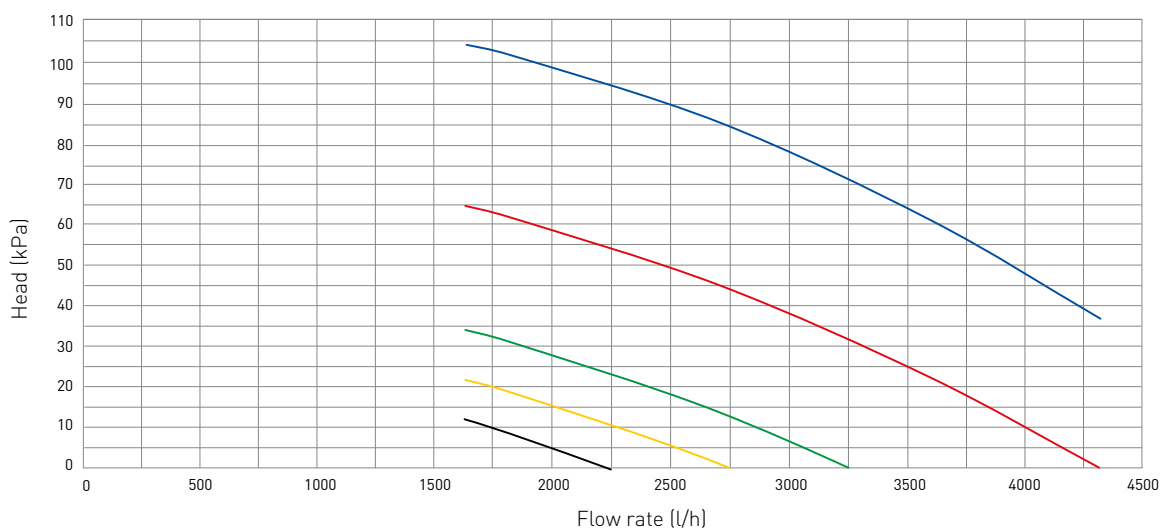

Available head in the system:

- pump speed 100%
- pump speed 75%
- pump speed 50%
- pump speed 38%
- pump speed 25%



Minimum distances for AUDAX 6/8/12/16/16 MONO installation

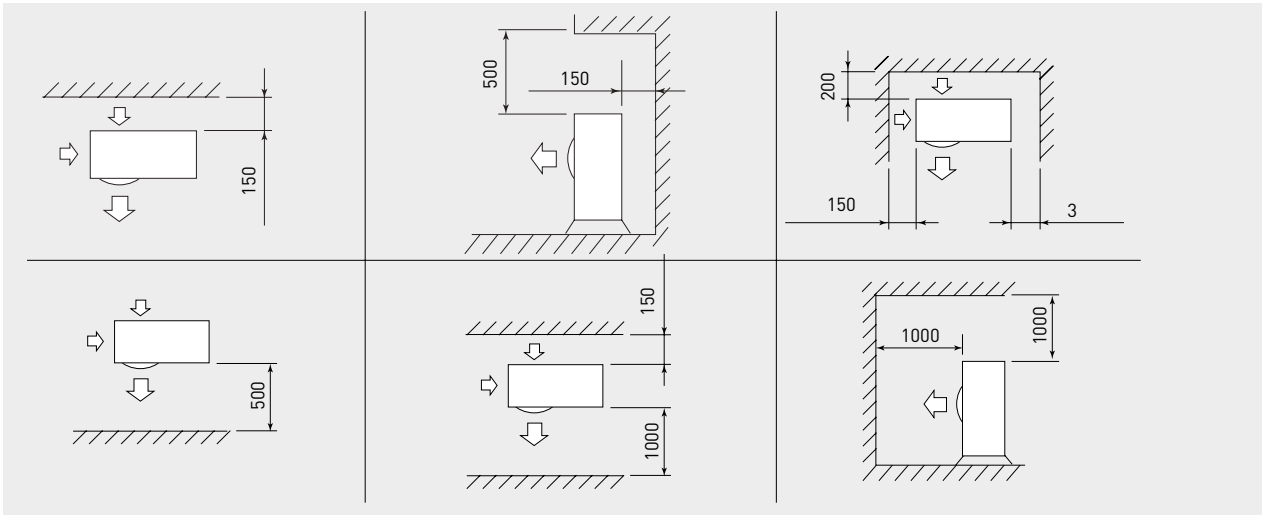

Minimum distances installation for AUDAX 6/8/12/16/16 MONO in cascade

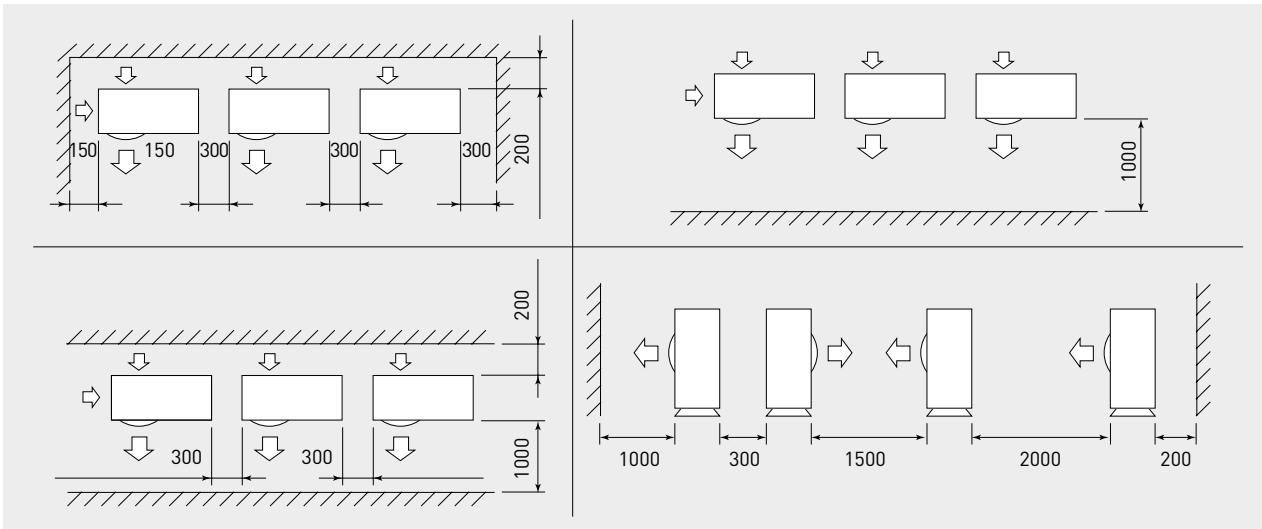

Minimum distances for AUDAX TOP 18/21 ErP installation

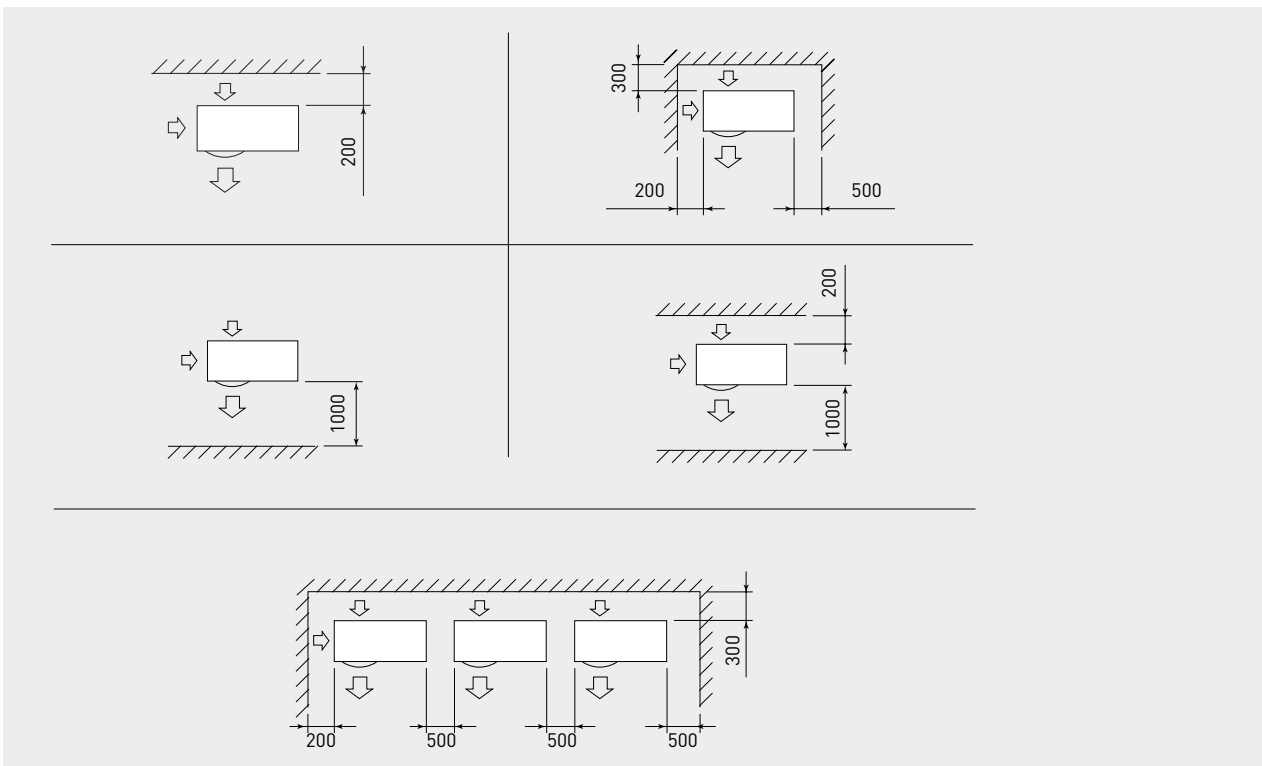

THERMOREGULATION

Type	Code	See page
System controller	3.021522	52
System controller expansion kit *	3.021547	52
Remote control kit	3.023364	52
Temperature/humidity active sensor kit	3.021524	53
Room hygrostat**	3.023302	53
CRONO 7 (weekly digital chronothermostat)	3.021622	52
CRONO 7 WIRELESS (wireless weekly digital chronothermostat)	3.021624	52
Storage tank NTC probe *	3.019375	53
Solar collector probe	3.019374	53
EMR 12 VDC relay kit	3.023945	53
SSR 6 VDC relay kit	3.023946	53
External probe kit	3.015266	52
Low temperature safety kit	3.019229	53
Low temperature safety kit (for kits code 3.021527 and 3.021528)	3.013794	53

* Standard accessory in the hydraulic kits code 3.021527 and 3.021528.

** To be used with radiant systems that also work in cooling mode.

OPTION KITS

Distribution manifold kit for 1 direct and 2 mixed temperature zones **	3.021527	56
Distribution manifold kit for 2 mixed temperature zones	3.021528	56
Horizontal buffer tank with capacity of 25 litres	3.027842	58
Horizontal buffer tank with capacity of 75 litres	3.027843	58
Horizontal buffer tank with capacity of 100 litres	3.027844	58
Horizontal buffer tank with capacity of 200 litres	3.027845	58
Dehumidifier kit (only for recessed installation with codes 3.022146 and 3.022147)*	3.021529	57
Dehumidifier back frame kit*	3.022146	57
Dehumidifier front grille kit*	3.022147	57
Return temperature increase 3-way valve kit	3.020632	56
12 litres system expansion vessel kit	3.011679	56
Integration electric resistance kit 2, 4 or 6 kW for heating system	3.021525	56
Additional 5 kW electric resistance kit for UB 1000/1500 V2 and UB 750 V2 (Thermal solar system)	3.020862	57
Additional 2 kW electric resistance kit for INOXSTOR 200/300/500 V2 and UB 550/750 V2 (Thermal solar system)	3.020861	57
Wall mounting brackets for AUDAX 6/8	3.022154	57
Connection kit 1" with anti-vibration flexible pipes and shut-off knobs	3.025954	56
HYDRO 3 water wall hung split	3.027918	54
HYDRO 4 water wall hung split	3.027919	54
UB INOX 120 V2	3.027818	55
UB INOX 200 V2	3.027819	55
UB INOX SOLAR 200 V2	3.027820	55
INOXSTOR 200 V2	3.027746	55
INOXSTOR 300 V2	3.027747	55
INOXSTOR 500 V2	3.027748	55
Vertical Buffer tank 50 litres	3.027539	58
Buffer tank 75 litres	3.027288	58
Wall-hung bracket kit for Buffer tank 75 litres	3.027290	58
Condensate anti-freeze heating cable kit for AUDAX 6/8/12	3.027385	57
Vibration-dampening feet kit AUDAX TOP 18 /21 ErP	3.027654	56

* Useful for radiant systems that work also in cooling.

** Direct zone means a zone operating at maximum temperature of AUDAX that is 60°C [57°C vers.21].



MAGIS PRO ErP

Split type reversible air/water heat pumps composed by an external unit and an indoor hydronic unit





IDEAL SOLUTIONS FOR NEW HOME

Available in **three versions (5, 8 and 10 kW)**, these system solutions **are ideal for new residential buildings with very high energy class even in areas with extremely low external temperature.**

IDEAL PROTECTION FROM FREEZING

The water circuit is completely protected from freezing, as it can be installed inside the building; MAGIS PRO ErP is the ideal application for cold regions.

COMPACT SOLUTION

The separate hydronic module houses the main parts of the hydraulic system, such as: supplementary resistance kit for the system (optional), expansion vessel, 3-way diverter valve for DHW.

LOW AESTHETIC IMPACT

The external unit is smaller than regular hydronic heat pumps, providing greater installation flexibility outside the building or on a balcony.

EASY INSTALLATION

Designers can use MAGIS PRO ErP in stand-alone heating, cooling and DHW solutions or connected to hydronic groups in order to realize recessed or in-house solutions TRIO V2/TRIO MONO V2 PRO (see page 32).





MAIN FEATURES OUTDOOR UNIT (AUDAX PRO)

- **Inverter technology rotative compressor** for all models
- Preloaded **refrigerant GAS R410A**
- **Shut off knobs R410A** as standard
- **Air finned heat exchanger** (with single fan)
- **Electronic lamination valve**
- **4-way valve for cycle inversion**
- Reversible **heating and cooling function**
- Possible **installation outdoor without protection**

MAIN FEATURES INDOOR HYDRONIC UNIT

- 48 plates **R410A / water exchanger**
- 12 litres **expansion vessel**
- **Flowmeter and water manifold** prearranged for additional 3 kW electric resistance kit (optional)
- **Hydraulic group - 7 mwc low consumption circulator**
- **3-ways divert valve** for connection at DHW storage tank
- **PCB prearranged to manage 2 zones (without System controller)**, 1 direct and 1 mixed (heating and cooling)
- **System Controller** (optional) to manage an integrated system with a gas boiler
- Standard **shut off knobs with 3/4" filter** for water circuit



Key

1	MAGIS PRO ErP
2	3 kW integration electric resistance kit (option)
3	DHW storage tank INOXSTOR ErP
4	Storage tank NTC probe
5	Integration electric resistance kit (option)
6	Safety inlet kit (not included)
7	Distribution manifold kit
8	Buffer tank (to be dimensioned)
9	Thermostatic mixing valve
10	CAR ^{V2}
11	Temperature / humidity active sensor kit

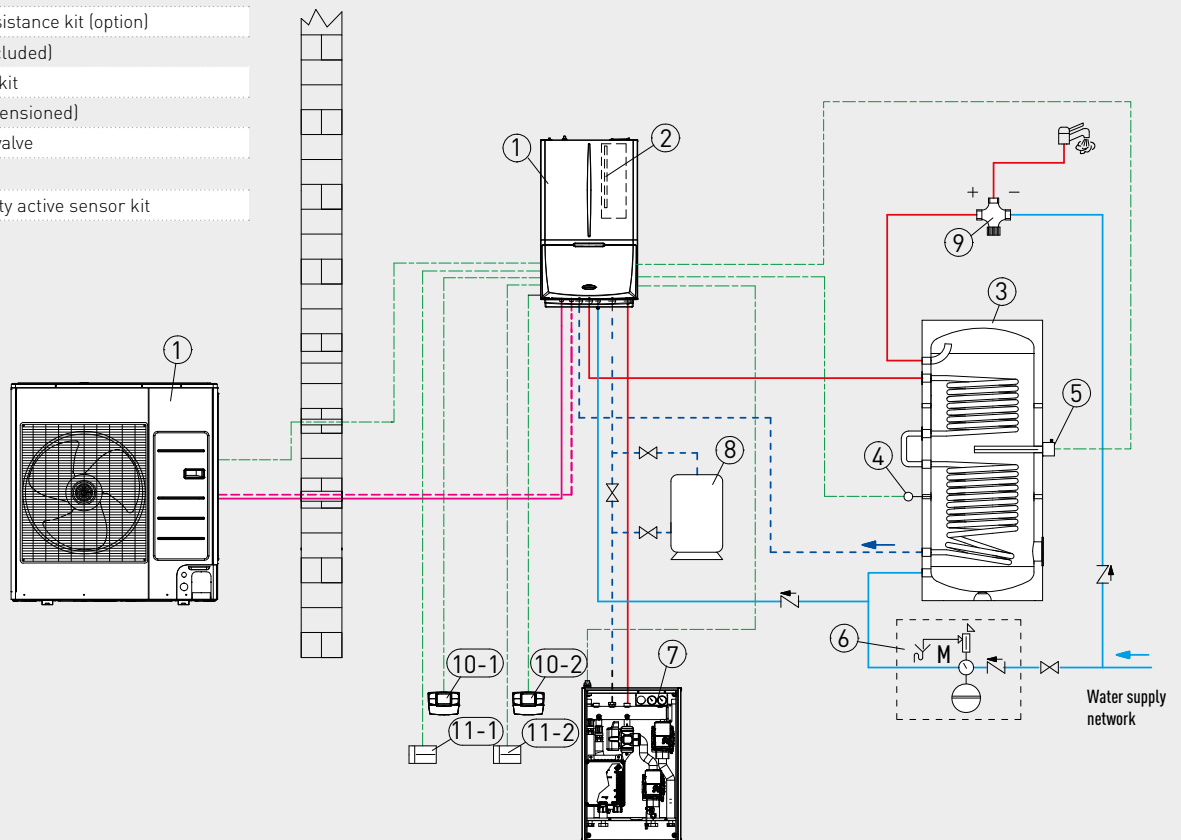

PLANT IN HEAT PUMP ALONE WITH MAGIS PRO ERP, IN-FLOOR HEATING AND COOLING, DEHUMIDIFICATION AND DHW WITH STORAGE TANK.

Heating mode

MAGIS PRO ErP is switched on by a request from one of the two system zones. The 3 kW resistance is activated if it does not reach the temperature set in the maximum time or, under a settable external temperature, I can switch on the resistance immediately.

Cooling mode

MAGIS PRO ErP is switched on by a request from one of the two system zones. The dehumidifiers are switched on by 2 relays board kit (option) located inside the hydronic units.

Domestic hot water mode

When the water temperature drops below the set point, the 3-way diverter valve located in the hydronic module switches to the storage tank and MAGIS PRO ErP starts producing DHW; the supplementary electric resistance of the boiler is switched on only in anti-legionella bacteria mode or with temperature set points above 55 °C.

NOTE: The inclusion and sizing of buffer tank will have to be decided based on the quantity of water in the heating system.

Technical characteristics	Unit of measurement	MAGIS PRO 5 ErP	MAGIS PRO 8 ErP	MAGIS PRO 10 ErP
Code		3.025694	3.025695	3.025696
Refrigerant quantity (R410A)	g	1.200	2.000	2.000
Liquid connection pipes R410A	mm-inch	6,35 - 1/4"	9,52-3/8"	9,52-3/8"
Gas connection pipes R410A	mm-inch	15,88 - 5/8"	15,88 - 5/8"	15,88 - 5/8"
Max length refrigerant pipes*	m	30	50	50
Max difference in height (with hydronic unit lower than external unit)	m	20	30	30
Max difference in height (with hydronic unit higher than external unit)	m	20	15	15
Heating capacity (system water 35 °C)	kW	5,80	7,71	9,70
Heating capacity (system water 45 °C)	kW	5,30	7,26	9,27
Heating capacity (system water 55 °C)	kW	4,80	6,17	8,45
Flow temperature range (CH)	°C	25-55	25-55	25-55
Outside air temperature range (CH)	°C	-20/35	-20/35	-20/35
COP (system water 35 °C)		4,53	4,08	4,09
COP (system water 45 °C)		3,42	3,13	3,11
COP (system water 55 °C)		2,64	2,34	2,35
Cooling capacity (system water 18 °C)	kW	6,03	7,58	7,58
Cooling capacity (system water 7 °C)	kW	4,90	5,33	7,31
Flow temperature range (cooling)	°C	7 - 25	7 - 25	7 - 25
Outside air temperature range (cooling)	°C	10/46	10/46	10/46
EER (system water 18 °C)		3,61	3,77	3,77
EER (system water 7 °C)		2,62	2,41	2,38
Maximum power absorbed condensate unit + Hydronic unit	kW	3,20	4,13	5,20
Power supply	V - Hz	230 - 50	230 - 50	230 - 50
Outdoor unit weight (empty)	kg	47,5	74,0	74,0
HYDRONIC UNIT TECHNICAL DATA				
Expansion vessel	l		12	
System circuit max pressure	bar		3	
Electric protection index	IP		X4D	
DHW range temperature (with resistance optional)	°C		10 - 50 (10 - 65)	
Weight (empty)	kg		33,50	

* If the distances are longer than 5 m (MAGIS PRO 5 ErP) or 15 m (MAGIS PRO 8 and 10 ErP), R410A have to be added.

Refer to the following conditions :

Environment	Heating [°C]	Cooling [°C]
T system water (R/M) - air (bs/bu)	30/35 - 7/6	23/18 - 35 (bs)
T system water (R/M) - air (bs/bu)	40/45 - 7/6	12/7 - 35 (bs)



Hydronic indoor unit

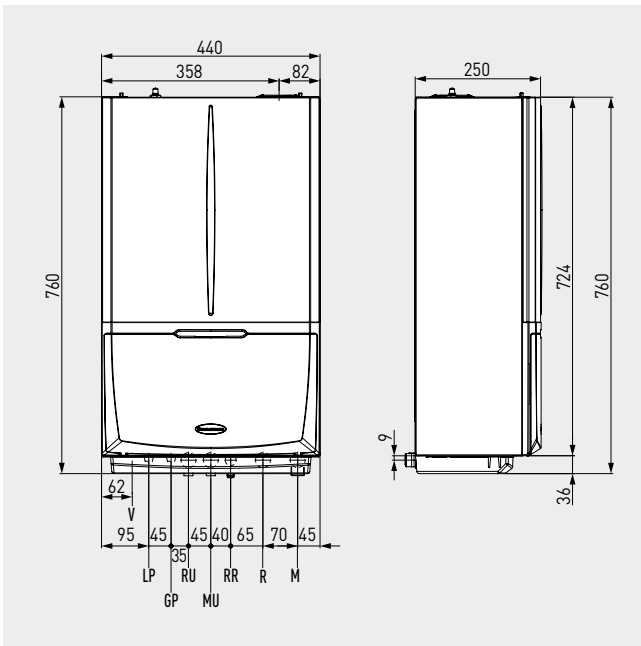

Key

LP	Liquid refrigerant
GP	Gas refrigerant
MU	Flow storage tank
RU	Return storage tank
R	System return
M	System flow
RR	Filling system

Connections

R410A		DHW		System
GP	LP	RR	RU-MU	R-M
5/8" (15,88 mm)	3/8" (9,52 mm)	1/2"	3/4"	3/4"

External unit AUDAX PRO 5

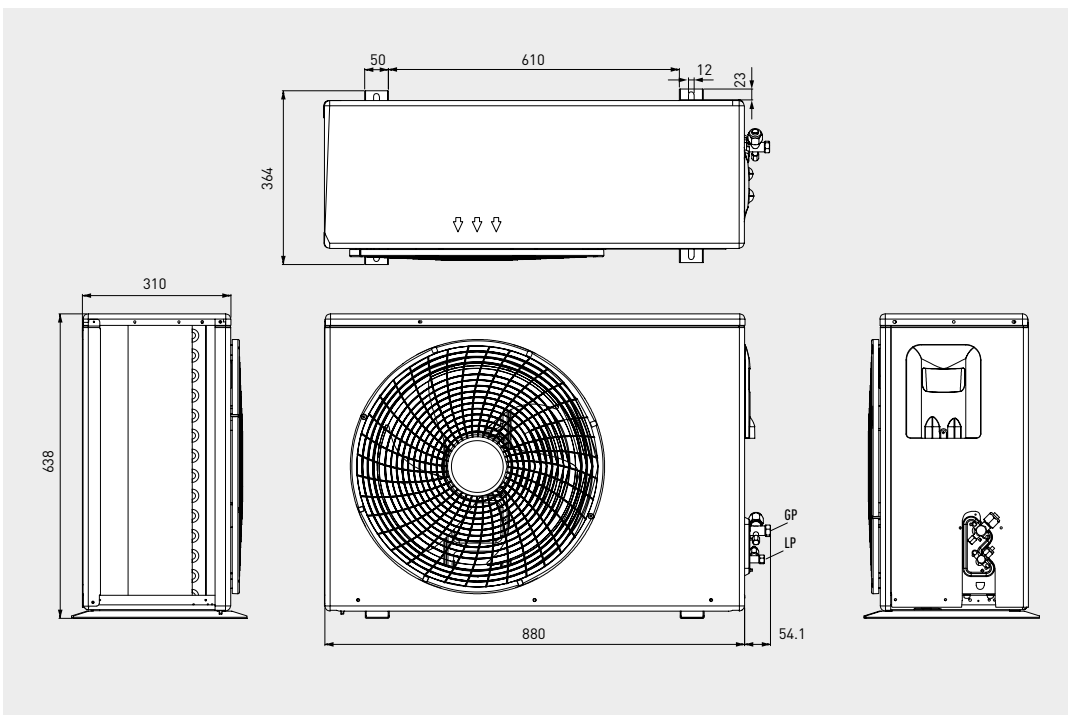

Connections

R410A	
GP (Gas refrigerant)	LP (Liquid refrigerant)
5/8" (15,88 mm)	1/4" (6,35 mm)

External unit AUDAX PRO 8/10

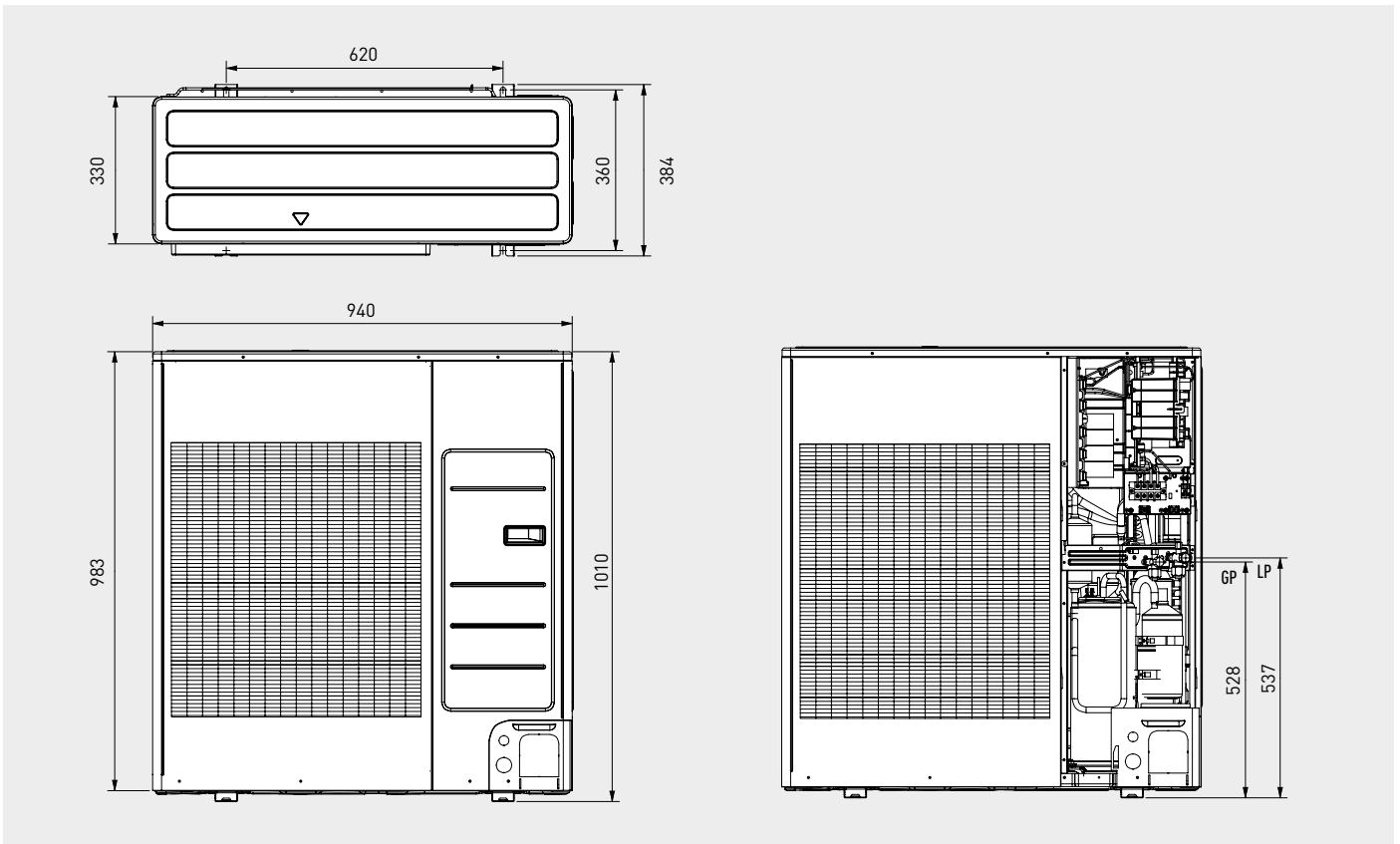

Connections

R410A

GP (gas refrigerant)	LP (liquid refrigerant)
5/8" [15,88 mm]	3/8" [9,52 mm]

Minimum distances for AUDAX PRO installation

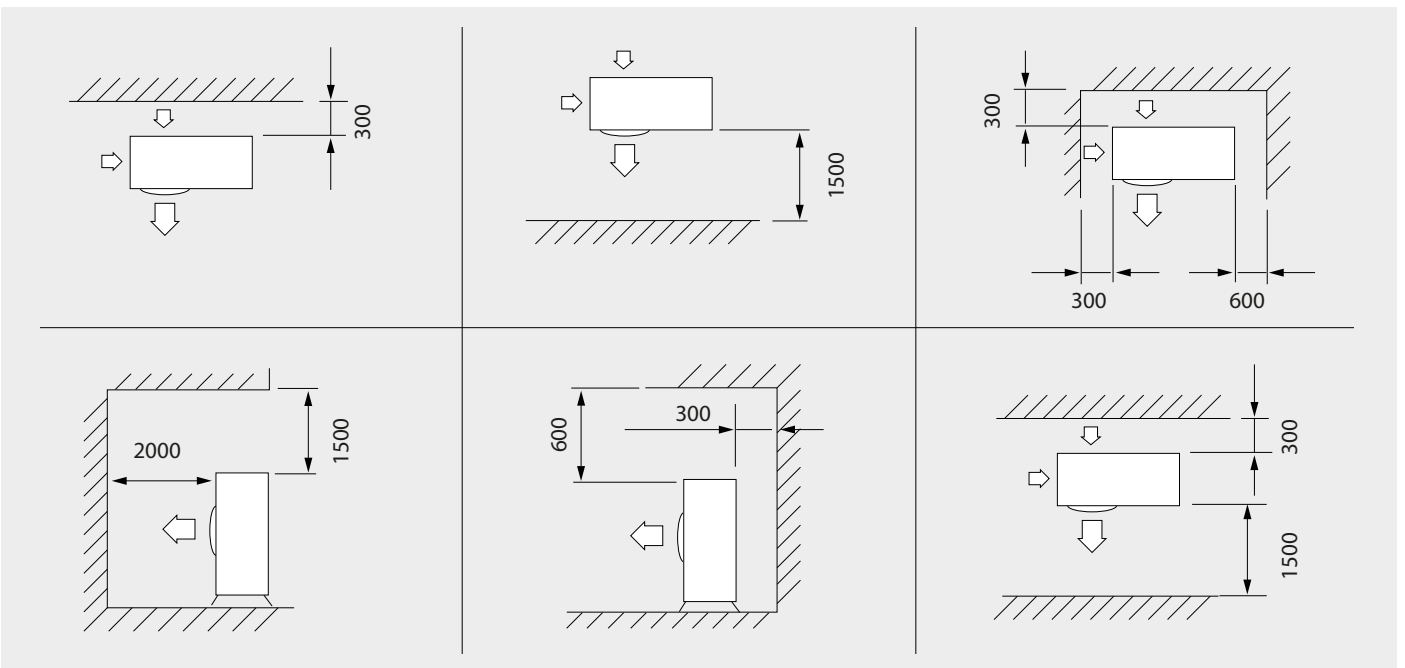

Internal unit circulator
flow rate/head graph

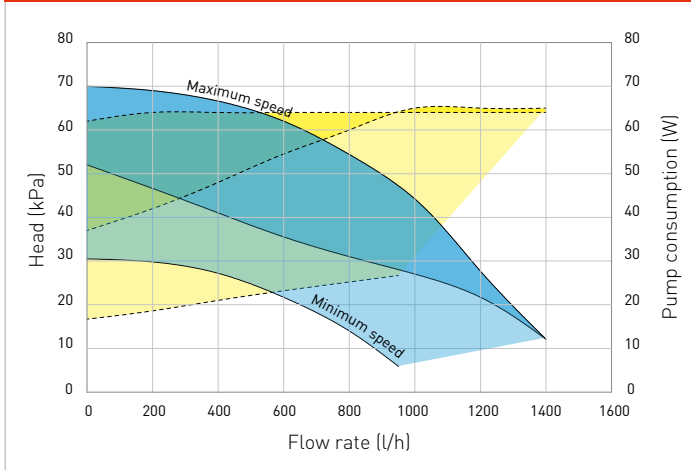

Key

- Available head in the system with excluded by-pass
- Available head in the system with inserted by-pass
- Pump consumption with excluded by-pass
- Pump consumption with inserted by-pass

MAGIS PRO 5 ErP	A+	A++
MAGIS PRO 8 ErP	A+	A++
MAGIS PRO 10 ErP	A+	A++

Note: The labels are shown in the documentation accompanying the units as well as on the immergas.com website in each product's page.

THERMOREGULATION

Type	Code	See page
Temperature/humidity active sensor kit**	3.021524	53
Room hygostat	3.023302	53
CAR ^{v2} (modulating remote control)	3.021395	53
CRONO 7 (weekly digital chronothermostat)	3.021622	52
CRONO 7 WIRELESS (wireless weekly digital chronothermostat)	3.021624	52
Storage tank NTC probe *	3.019375	53
Solar collector probe	3.019374	53
EMR 12 VDC relay kit	3.023945	53
SSR 6 VDC relay kit	3.023946	53
2 relays board kit to manage the dehumidifiers	3.026302	53
External probe kit	3.015266	52
Low temperature safety kit	3.019229	53
Low temperature safety kit (for kit code 3.026301)	3.013794	53
Relay board kit	3.015350	53

* Standard accessory in the hydraulic kit code 3.026301

** To be used with radiant systems that also work in cooling mode.

OPTION KITS

Distribution manifold kit for 1 direct and 1 mixed temperature zones (direct connection)	3.026301	56
Connection kit for R410A circuit	3.026089	57
Dehumidifier kit**	3.021529	57
Dehumidifier back frame kit**	3.022146	57
Dehumidifier front grille kit**	3.022147	57
Return temperature increase 3-way valve kit	3.020632	56
12 litres expansion vessel kit	3.011679	56
3 kW integration electric resistance kit	3.026300	56
Additional 5 kW electric resistance kit for UB 1000/1500 V2 and UB 750 V2	3.020862	57
Additional 2 kW electric resistance kit for INOXSTOR 200/300/500 V2 and UB 550/750 V2	3.020861	57
Anti freeze protection kit -15 °C	3.017324	57
HYDRO 3 water wall hung split	3.027918	54
HYDRO 4 water wall hung split	3.027919	54
UB INOX 120 V2	3.027818	55
UB INOX 200 V2	3.027819	55
UB INOX SOLAR 200 V2	3.027820	55
INOXSTOR 200 V2	3.027746	55
INOXSTOR 300 V2	3.027747	55
INOXSTOR 500 V2	3.027748	55
Vertical Buffer tank 50 litres	3.027539	58
Buffer tank 75 litres	3.027288	58
Wall-hung bracket kit for Buffer tank 75 litres	3.027290	58
Condensate anti-freeze heating cable kit	3.027385	57
Wall mounting brackets for external unit	3.022154	57

* To be used with radiant systems that also work in cooling mode.

** Only for recessed installation with codes 3.022146 and 3.022147.



TRIO V2/TRIO MONO V2

Great versatility to set up 4 different solutions





COMPLETE SYSTEM WITH RENEWABLES

Heating in winter, cooling in summer and domestic hot water all year round. TRIO V2/TRIO MONO V2 are the hydronic units designed to combine different energy sources: renewable and conventional.

GREAT VERSATILITY

Thanks to the versatility of TRIO, professionals can set up different systems, choosing the one that best suits the building. It is designed to combine with condensing boilers, air-water heat pumps, solar thermal and electrical resistances: this makes it possible to create 4 different system solutions and to adapt to the energy sources that are available.

REDUCED SPACE REQUIREMENTS

The TRIO V2/TRIO MONO V2 solutions offer complete units in a limited space: they can be installed in the recessed frame SOLAR CONTAINER or directly inside the home in the special technical box DOMUS CONTAINER.

STANDARD REMOTE PANEL

TRIO comes with a wide-display panel for easy reading of parameter settings to let you control the system from a remote location, manage the various configurations of the system and check temperature and humidity in an area.

COST SAVINGS

Thanks to TRIO COMBI and PLUS versions it is possible to save on gas consumptions as the electronic switch on the appliance more advantageous according to external temperature and delivery temperature. With TRIO BASE and PRO versions it is possible to save on costs to realize gas plant (as it does not need a gas system installing induction hobs too) and to place chimney.





REMOTE CONTROL PANEL AS STANDARD

With huge and friendly display the control panel can be used not only as main device for the settlement of the parameters but also as weekly thermostat for managing heating/cooling with room temperature/humidity sensor.

Main functions:

- **Identification of each single zone:** heating only, cooling/heating, cooling/heating with dehumidification, cooling only, cooling only with dehumidification
- **possibility to set the climatic curve** for each single zone
- **adjustment of the cut-off temperature or the COP calculation** for AUDAX functioning
- **possibility of keeping AUDAX in operation** even during the gas boiler functioning (PLUS and COMBI systems)

.01 SOLAR CONTAINER (code 3.020166)

Our SOLAR CONTAINER recessed frame is the first of the main components of TRIO V2/TRIO MONO V2 systems. It allows the housing of the main components (except for the AUDAX heat pump and the external unit of MAGIS PRO ErP).

It can be ordered and installed during the building planning stage and provides the installer with all the system features for subsequent installation of generators, hydraulic parts and flues (if any). Front access enables total maintenance of the system.

.02 DOMUS CONTAINER (code 3.022167)

The DOMUS CONTAINER technical box is the first of the main components of TRIO V2/TRIO MONO V2 systems for indoor installations. It allows the housing of the main components (except for the AUDAX heat pump and the external unit of MAGIS PRO ErP).

It blends easily into any room and does not require no brickwork for subsequent installation of generators, hydraulic components and flues (if any). Front opening enables total system maintenance.

.01**.02**

BASE SYSTEM

Only monobloc heat pump solution ideal for designing in locations with mild winter temperatures



ESSENTIAL COMPONENTS

BOX

Depending on the installation needs, it is possible to choose between:

- SOLAR CONTAINER (code 3.020166) for recessed installation
- DOMUS CONTAINER (code 3.022167) for indoor installation

TRIO V2 (code 3.027830) - TRIO MONO V2 (code 3.027831)

Including:

- DHW storage tank in stainless steel with double coil 160 litres of capacity (class C), with 2 magnesium anodes, insulation and inspection flange
- system controller integrated. Remote panel control supplied as standard suitable also as thermoregulator (class VI)
- hydraulic distribution unit that includes:
 - 2 zones (one direct and one mixed) with low consumption pumps for TRIO V2
 - 1 zone (direct) with low consumption pump for TRIO MONO V2
 - hydraulic manifold
 - 1 three-way valve,
 - 1 mixing valve (for TRIO V2)
 - DHW expansion vessel 8 litres
 - DHW safety valve 8 bar
 - thermostatic mixing valve
 - 2 thermometers for TRIO V2 and 1 for TRIO MONO V2

AUDAX CONNECTION KIT (code 3.024713)

Including: hydraulic fittings, expansion vessel and manometer.

MONOBLOC HEAT PUMP

It is possible to choose between:

- AUDAX 6 (code 3.027809)
- AUDAX 8 (code 3.027810)
- AUDAX 12 (code 3.027811)

CONNECTION KIT

- Bottom connection kit (code 3.020575)
- Lateral connection kit (code 3.020574)
- Rear connection kit (code 3.020630)



PRO SYSTEM

Only split type heat pump solution with outdoor unit and indoor hydronic unit



ESSENTIAL COMPONENTS

BOX

Depending on the installation needs, it is possible to choose between:

- SOLAR CONTAINER (code 3.020166) for recessed installation
- DOMUS CONTAINER (code 3.022167) for indoor installation

TRIO V2 (code 3.027830) - TRIO MONO V2 (code 3.027831)

Including:

- DHW storage tank in stainless steel with double coil 160 litres of capacity (class C), with 2 magnesium anodes, insulation and inspection flange
- system controller integrated. Remote panel control supplied as standard suitable also as thermoregulator (class VI)
- hydraulic distribution unit that includes:
 - 2 zones (one direct and one mixed) with low consumption pumps for TRIO V2
 - 1 zone (direct) with low consumption pump for TRIO MONO V2
 - hydraulic manifold
 - 1 three-way valve,
 - 1 mixing valve (for TRIO V2)
 - DHW expansion vessel 8 litres
 - DHW safety valve 8 bar
 - thermostatic mixing valve
 - 2 thermometers for TRIO V2 and 1 for TRIO MONO V2

MAGIS PRO ERP CONNECTION KIT (code 3.026303)

Including: hydraulic and gas R410A fittings, support bracket for indoor unit of MAGIS PRO ErP and NTC probe for storage tank.

SPLIT TYPE HEAT PUMP

It is possible to choose between:

- MAGIS PRO 5 ErP (code 3.025694)
- MAGIS PRO 8 ErP (code 3.025695)
- MAGIS PRO 10 ErP (code 3.025696)

CONNECTION KIT

- Bottom connection kit (code 3.020575)
- Lateral connection kit (code 3.020574)
- Rear connection kit (code 3.020630)



PLUS SYSTEM

Hybrid solution with heat pump and condensing gas boiler
ideal for housing units with high DHW needs



ESSENTIAL COMPONENTS

BOX

Depending on the installation needs, it is possible to choose between:

- SOLAR CONTAINER (code 3.020166) for recessed installation
- DOMUS CONTAINER (code 3.022167) for indoor installation

TRIO V2 (code 3.027830) - TRIO MONO V2 (code 3.027831)

Including:

- DHW storage tank in stainless steel with double coil 160 litres of capacity (class C), with 2 magnesium anodes, insulation and inspection flange
- system controller integrated. Remote panel control supplied as standard suitable also as thermoregulator (class VI)
- hydraulic distribution unit that includes:
 - 2 zones (one direct and one mixed) with low consumption pumps for TRIO V2
 - 1 zone (direct) with low consumption pump for TRIO MONO V2
 - hydraulic manifold
 - 1 three-way valve,
 - 1 mixing valve (for TRIO V2)
 - DHW expansion vessel 8 litres
 - DHW safety valve 8 bar
 - thermostatic mixing valve
 - 2 thermometers for TRIO V2 and 1 for TRIO MONO V2

BOILER PLUS CONNECTION KIT (code 3.024711)

Including: support bracket for only heating gas boiler, NTC probe for storage tank and hydraulic fitting

CONDENSING GAS BOILER

VICTRIX TERA 24 PLUS (code 3.027373)

MONOBLOC HEAT PUMP

It is possible to choose between:

- AUDAX 6 (code 3.027809)
- AUDAX 8 (code 3.027810)
- AUDAX 12 (code 3.027811)

CONNECTION KIT

- Bottom connection kit (code 3.020575)
- Lateral connection kit (code 3.020574)
- Rear connection kit (code 3.020630)



COMBI SYSTEM

Hybrid solution with heat pump and condensing gas boiler
ideal up to three-roomed housing units



ESSENTIAL COMPONENTS

BOX

A seconda dell'esigenza installativa, è possibile scegliere fra:

- SOLAR CONTAINER (code 3.020166) per installazione ad incasso sulle pareti esterne dell'edificio
- DOMUS CONTAINER (code 3.022167) per installazione in armadio tecnico all'interno degli ambienti

TRIO V2 (code 3.027830) - TRIO MONO V2 (code 3.027831)

Including:

- DHW storage tank in stainless steel with double coil 160 litres of capacity (class C), with 2 magnesium anodes, insulation and inspection flange
- system controller integrated. Remote panel control supplied as standard suitable also as thermoregulator (class VI)
- hydraulic distribution unit that includes:
 - 2 zones (one direct and one mixed) with low consumption pumps for TRIO V2
 - 1 zone (direct) with low consumption pump for TRIO MONO V2
 - hydraulic manifold
 - 1 three-way valve,
 - 1 mixing valve (for TRIO V2)
 - DHW expansion vessel 8 litres
 - DHW safety valve 8 bar
 - thermostatic mixing valve
 - 2 thermometers for TRIO V2 and 1 for TRIO MONO V2

BOILER COMBI CONNECTION KIT (code 3.024712)

Including: support bracket for combi gas boiler and hydraulic fitting

CONDENSING GAS BOILER

It is possible to choose between:

- VICTRIX TERA 28 (code 3.027370)
- VICTRIX TERA 32 (code 3.027371)

MONOBLOC HEAT PUMP

It is possible to choose between:

- AUDAX 6 (code 3.027809)
- AUDAX 8 (code 3.027810)
- AUDAX 12 (code 3.027811)

CONNECTION KIT

- Bottom connection kit (code 3.020575)
- Lateral connection kit (code 3.020574)
- Rear connection kit (code 3.020630)



Recessed frame SOLAR CONTAINER

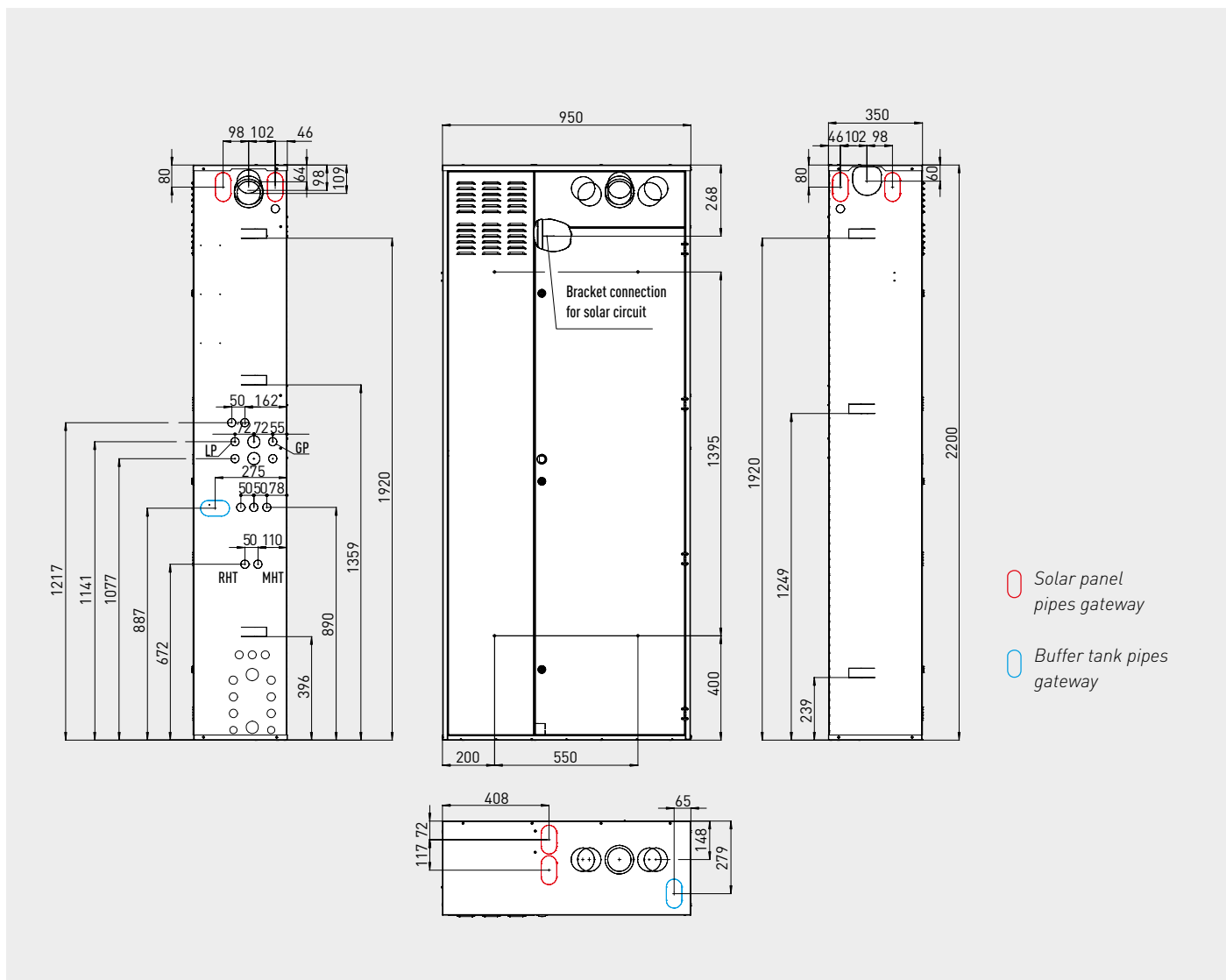

Pay attention: Gateway for hydraulic connections to AUDAX (MHT e RHT) and for gas R410A connections in TRIO PRO versions (GP e LP) is only on the right side of SOLAR CONTAINER.

VICTRIX TERA/PLUS

FRONT AND REAR EXHAUST PIPE CONNECTION

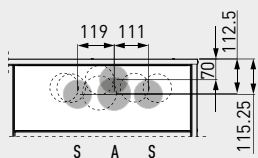

SUPERIOR EXHAUST PIPE CONNECTION

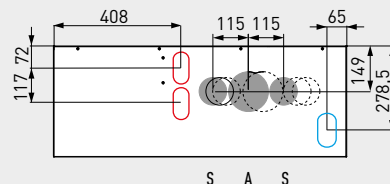

A Inlet/outlet - S Inlet

Pay attention: With \varnothing 60/100 horizontal concentric flue kit it is always necessary to use the Flanged stub-pipe kit \varnothing 60/100 (code 3.012086), 90° bend \varnothing 60/100 kit (code 3.012093) and Extension pipe kit \varnothing 60/100 0,5 m long (code 3.014643).

Recessed frame SOLAR CONTAINER

REAR HYDRAULIC CONNECTION

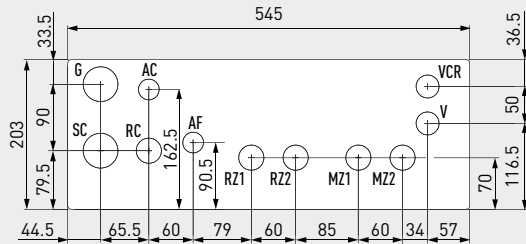

BOTTOM HYDRAULIC CONNECTION

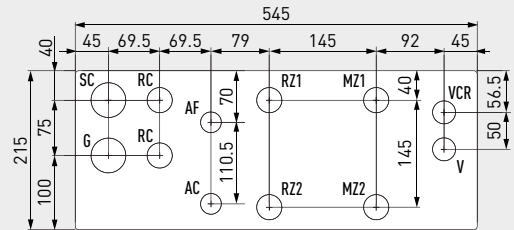

RIGHT LATERAL HYDRAULIC CONNECTION

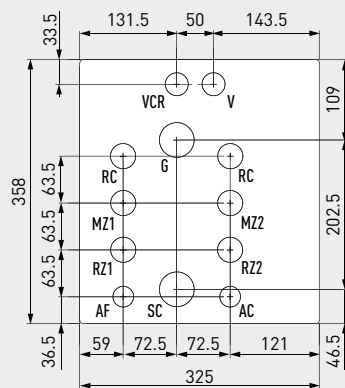

Key

G	Gas supply
AC	Domestic hot water outlet
AF	Domestic cold water inlet
MHT	Heat pump delivery (only for AUDAX)
RHT	Heat pump return (only for AUDAX)
GP	Gas refrigerant (only for TRIO V2/TRIO MONO V2 PRO)
LP	Liquid refrigerant (only for TRIO V2/TRIO MONO V2 PRO)
MZ1	System delivery zone 1
RZ1	System return zone 1
MZ2	System delivery zone 2
RZ2	System return zone 2
RC	Recirculation kit 1/2" (except COMBI version)
SC	Condensate drain
V	Electrical connection
VCR	Modulating remote control

Pay attention: Dimensions refer to the stickers applied inside the SOLAR CONTAINER

	Zone 1	Zone 2
TRIO V2	Low temperature zone (mixed zone)	High temperature zone (direct zone)
TRIO MONO V2	Not provided	Direct zone

Hydraulic connection

Gas	D.H.W.		System			
G	AC	AF	RZ1	MZ1	RZ2	MZ2
1/2"	1/2"	1/2"	3/4"	3/4"	3/4"	3/4"

Note: SOLAR CONTAINER presents further gateways on the right side (indicatively in a central position). In case of use of this arrangement, no connection groups is provided.



Technical box DOMUS CONTAINER

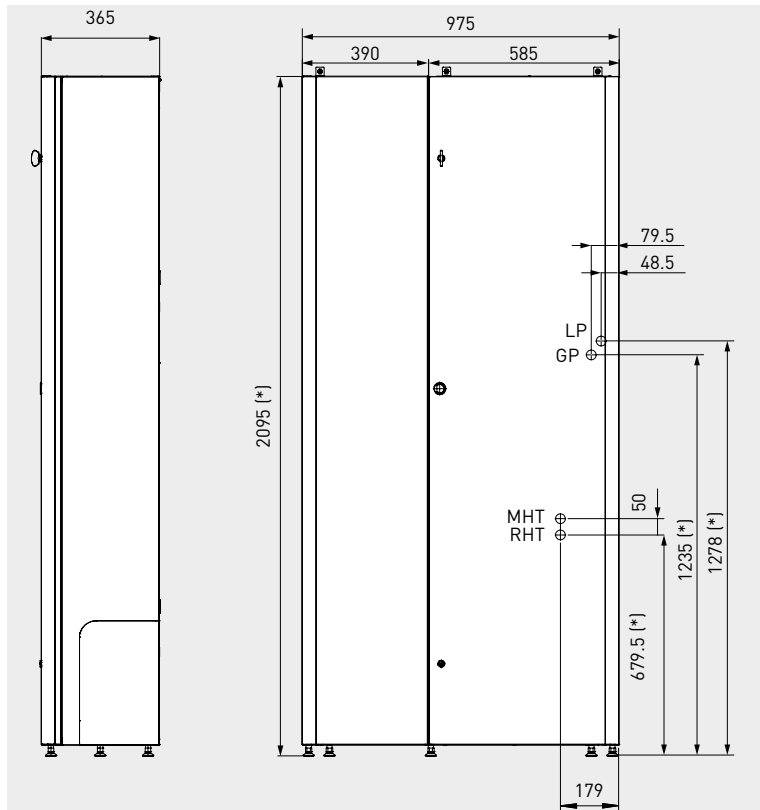

(*) Dimensions with feet at the minimum adjustment. Feet Adjustment from 35 to 55 mm, therefore the dimension shown can increase + 15 mm

Pay attention: Gateway for hydraulic connections to AUDAX (MHT e RHT) and for gas R410A connections in TRIO PRO versions (GP e LP) is only on the rear side of DOMUS CONTAINER.

To cover the upper part of the DOMUS CONTAINER and all the additional components it is necessary to use the **aesthetic upper cover kite** code 3.027175

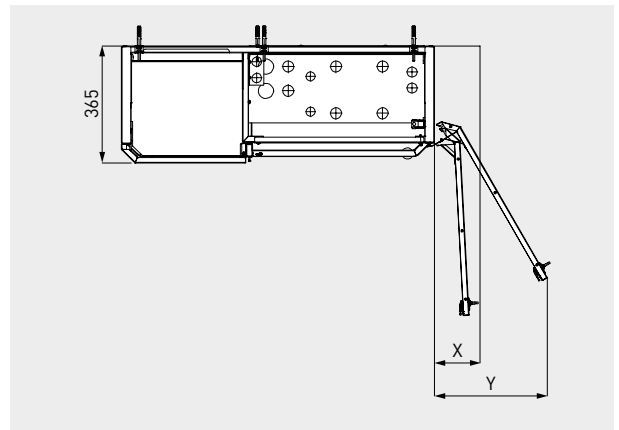

X = 140 cm Minimum dimension in order to open and disassembly the door
Y = 350 cm Maximum door opening - not essential -

Key

G	Gas supply
AC	Domestic hot water outlet
AF	Domestic cold water inlet
MHT	Heat pump delivery (only for AUDAX)
RHT	Heat pump return (only for AUDAX)
GP	Gas refrigerant (only for TRIO V2/TRIO MONO V2 PRO)
LP	Liquid refrigerant (only for TRIO V2/TRIO MONO V2 PRO)
MZ1	System delivery zone 1
RZ1	System return zone 1
MZ2	System delivery zone 2
RZ2	System return zone 2
RC	Recirculation kit 1/2" (except COMBI version)
SC	Condensate drain
V	Electrical connection
VCR	Modulating remote control1

	Zone 1	Zone 2
TRIO V2	Low temperature zone (mixed zone)	High temperature zone (direct zone)
TRIO MONO V2	Not provided	Direct zone

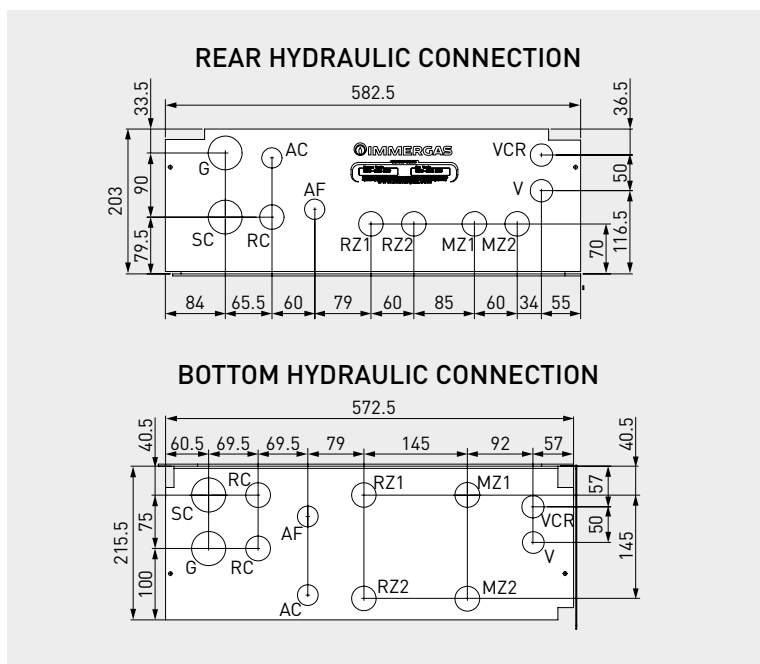

Pay attention: Dimensions refer to the stickers applied inside the DOMUS CONTAINER.

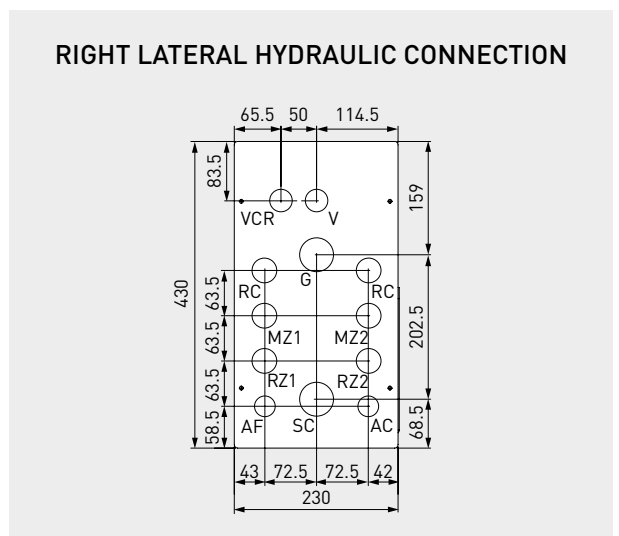

Connection

Gas	D.H.W		System				AUDAX		MAGIS PRO ErP	
G	AC	AF	MZ1	RZ1	MZ2	RZ2	MHT	RHT	LP	GP
1/2"	1/2"	1/2"	3/4"	3/4"	3/4"	3/4"	3/4"	3/4"	3/8" [9,52 mm]	5/8" [15,88 mm]

FLUE KIT for DOMUS CONTAINER

VICTRIX TERA/PLUS

CONFIGURATION WITH HORIZONTAL CONCENTRIC KIT Ø 60/100

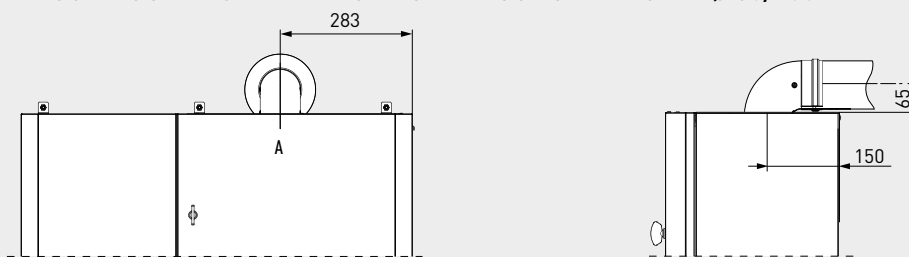

Flanged stub-pipe kit Ø 60/100 code 3.012086
 90° bend Ø 60/100 kit code 3.012093
 Extension pipe kit Ø 60/100 0,5m long code 3.014643

CONFIGURATION WITH TWIN PIPE KIT Ø 80

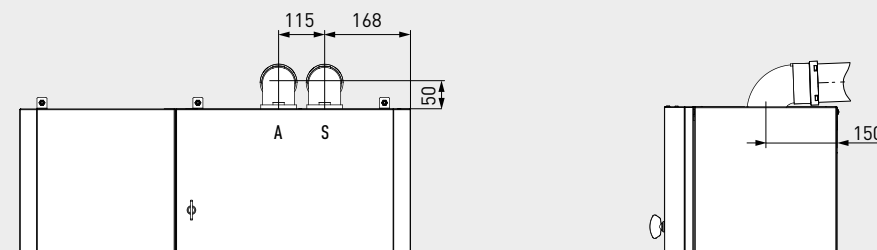

Twin pipe kit Ø 80 code 3.012002

A Inlet/outlet - S Inlet

FLOW RATE/HEAD GRAPHS TRIO SYSTEMS

Direct zone

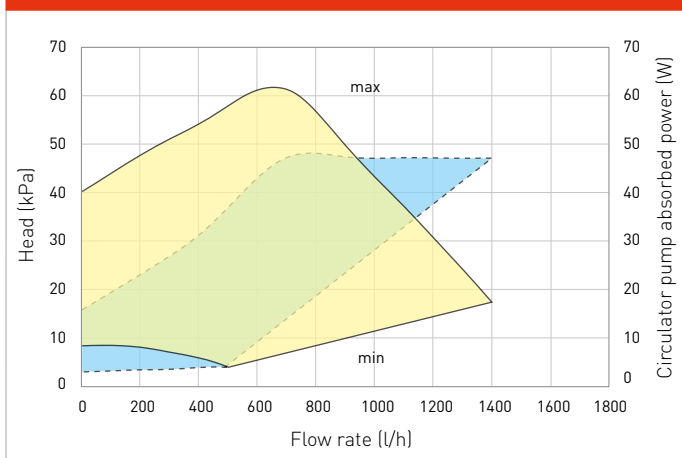

Mixed zone (only for TRIO V2)

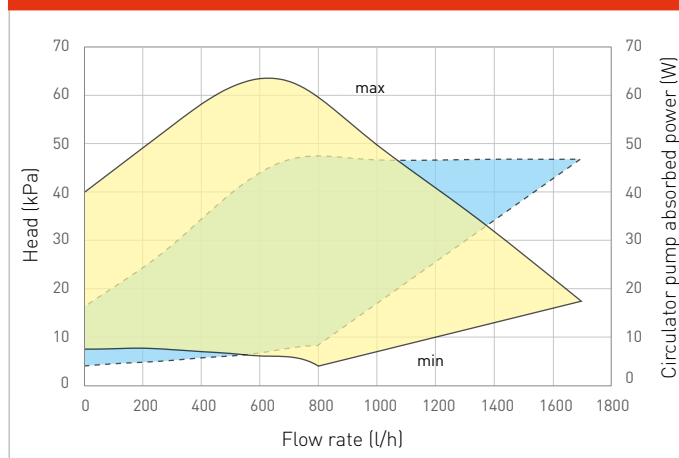

Key

- Available head
- Power absorbed by the pump (dotted area)





.03



.03 SOLAR KIT (CODE 3.024719)

Special option kit designed to take advantage of solar thermal energy for domestic hot water production. Including:

- single solar low consumption pump
- solar central unit
- 16 plates heat exchanger
- fitting and pipes
- 12 litres solar expansion vessel
- temperature probes (for storage tank and solar collector)

The kit can be completely installed inside the SOLAR CONTAINER or DOMUS CONTAINER and can be used with TRIO V2/TRIO MONO V2 (BASE, PRO, COMBI and PLUS).

In order to complete solar thermal system it is necessary to add:

- 1 or 2 **flat-plate** collectors CP4 M or 1 CP4 XL and hydraulic connections
- support frame and relative fixing system for **flat-plate** collectors to be chosen based on the roof (with brackets, recessed or free-standing).
- premixed glycol
- connection pipes between solar collector and storage tank

The list provided is to be considered approximative; for design and setup of plants it is always necessary to refer to qualified professionals, who will ensure the correct sizing of solar systems. For this component, refer to the specific documentation.

THERMOREGULATION

Type	Code
CAR v2 (modulating remote control) only for TRIO PRO	3.021395
CAR v2 WIRELESS (wireless modulating remote control) only for TRIO PRO	3.021623
Remote control kit (modulating remote control) only for TRIO PRO	3.023364
External probe kit (for TRIO COMBI e PLUS)	3.014083
External probe kit (for TRIO PRO)	3.015266
CRONO 7 (weekly digital chronothermostat)	3.021622
CRONO 7 WIRELESS (wireless weekly digital chronothermostat)	3.021624
Temperature/humidity active sensor kit* (not suitable for TRIO MONO V2)	3.021524
Room hygostat*	3.023302
Solar probe kit for TRIO COMBI	3.021452
Low temperature safety kit	3.013794

FLUE KITS FOR TRIO/TRIO MONO V2 COMBI AND PLUS

Intake-exhaust kit "Green Series" for configuration type C

Twin pipe complete kit Ø 80	3.012002
Vertical concentric complete kit Ø 60/100 (red ochre colour)	3.016833
Horizontal excentric exhaust kit Ø 60/100: 1 flanged stub-pipe kit Ø 60/100	3.012086
1 90° bend Ø 60/100 kit	3.012093
1 extension pipe kit Ø 60/100 0.5 m long	3.014643

Note: flue systems are PPS manufactured therefore suitable exclusively for condensing boilers

Exhaust kit "Green Series" for outdoor installation in solar container with direct air intake

Flanged stub-pipe + bend + extension pipe Ø 80 for flue discharge	3.016365
Flanged stub-pipe kit Ø 80 (use only the air flange)	3.012087
4 x 90° bends Ø 80 kit (use only the 1 bend)	3.012091

Note: flue systems are PPS manufactured therefore suitable exclusively for condensing boilers

OPTION KITS

Anti scale kit	3.020628
Horizontal buffer tank with capacity of 25 litres	3.027842
Horizontal buffer tank with capacity of 75 litres	3.027843
Horizontal buffer tank with capacity of 100 litres	3.027844
Horizontal buffer tank with capacity of 200 litres	3.027845
Recessed buffer tank 50 litres (for installations in SOLAR CONTAINER)	3.027709
Connection kit for AUDAX and buffer tank 3.027709 (when buffer tank is installed at the side of SOLAR CONTAINER)	3.028171
Dehumidifier kit*	3.021529
Dehumidifier back frame kit*	3.022146
Dehumidifier front grille kit*	3.022147
Vertical Buffer tank 50 litres (suitable for AUDAX 6 and 8)	3.027539
Buffer tank 15 litres for TRIO PRO	3.026304
Buffer tank 75 litres	3.027288
Wall-hung bracket kit for buffer tank 75 litres code 3.027288	3.027290
HYDRO 3 water wall hung split	3.027918
HYDRO 4 water wall hung split	3.027919
3 kW integration electric resistance kit for TRIO PRO	3.026300
Integration electric resistance kit 2, 4 or 6 kW for heating system for TRIO BASE	3.021525
Integration electric resistance kit 1,5 kW for D.H.W. for TRIO BASE and PRO	3.024897
Recirculation kit without pump	3.026169
Anti-freeze protection kit	3.017324

* To be used with radiant systems that also work in cooling mode.



RAPAX V2

Heat pump water heaters





REDUCED CONSUMPTION AND RESPECT FOR THE ENVIRONMENT

RAPAX V2 range water heaters significantly reduce polluting emissions compared to traditional gas water heaters. Thanks to a heat pump, they use the heat in the air as a source of free, renewable energy for heating water. Through an electrical contact, they can also store the heat produced with the photovoltaic system in the boiler. The RAPAX 300 SOL V2 version can be combined with a forced-circulation solar heating system to further reduce power consumption.

SILENT OPERATION

RAPAX V2 have the lowest sound impact in the field so they are suitable for installation in living areas.

EASE OF INSTALLATION

These water heaters can also be installed in non-heated areas such as a garage, laundry or storeroom; they do not require extensive work apart from holes for air discharge in solutions that call for suction and external exhaustion of air.

SIMPLICITY AND EASE OF USE

RANGE FOR ALL NEEDS

RAPAX V2 range offers 2 floor standing models with 270 liters vitrified steel storage (RAPAX 300 V2 and RAPAX 300 SOL V2 with solar coil) and 1 wall hung model with 100 liters storage, in vitrified steel (RAPAX 100 V2). The whole range represents an excellent alternative to solar energy; it can be used in systems built to work without gas for the production of domestic hot water and in combination with a heat pump for heating/cooling.





USER INTERFACE AND FUNCTIONS

New integrated interface allows an easier use. The control lets you view measured temperature, operation times of heat pump or electrical supplement energy consumption in kWh, activation of the solar heating circuit (only in the RAPAX 300 SOL V2 version) as well as setting of **anti-legionella function**. The operation modes as AUTO, ECO and BOOST are always present, but there are two new functions (see below).

Operation modes	Description
MANUAL	Heat pump operation has priority; in case of problems/error signal or temperature outside the normal range (- 5 + 43 °C), the electrical resistance is switched on (manual adjustment range 50 - 62 °C)
ABSENCE	It allows you to indicate a permanent absence or a scheduled absence (set the start and the end date). In this period, the water temperature is kept above 15°C.



SOLAR HEATING COMBINATION

The RAPAX 300 SOL V2 version has been designed to supplement DHW production with a forced-circulation solar heating system* connected to the special fittings of the bottom coil**. The solar heating system is completed by addition of:

- Flat Plate Collector CP4 M or CP4 XL
- Connection kit for Flat Plate Collector (including vent kit and fittings)
- Frame and brackets for Flat Plate Collector
- Glycol and connections pipes storage tank and Flat Plate Collector
- Central solar unit and Solar pump station
- Solar expansion vessel

** It is available a specific documentation for solar thermal solutions.*

*** Alternative at the solar heating system, it is possible to connect a boiler. For more information contact the presales-dept.*



.04 INSTALLATION WITHOUT DUCTS IN UNHEATED SPACES (volume > 20 m³)

Very useful in a laundry, garage or utility room. In the laundry the advantage is the room dehumidification and the recovery of the wasted heat from washing machines and dryers.

.04

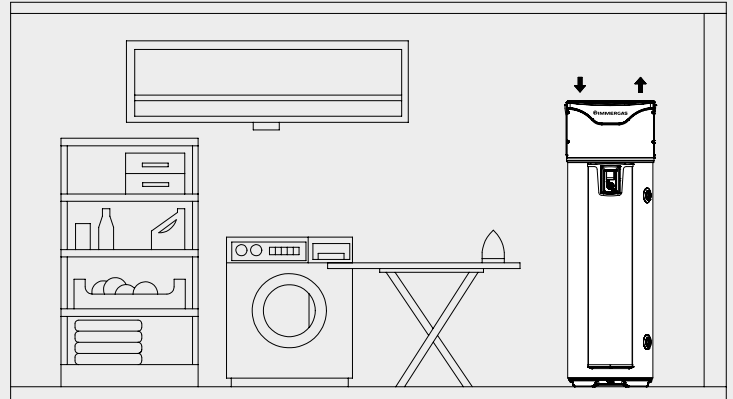

.05 INSTALLATION IN UNHEATED SPACES (volume > 20 m³), WITH 1 EXPULSION DUCT

In this case, a ventilation opening must be done.

.05

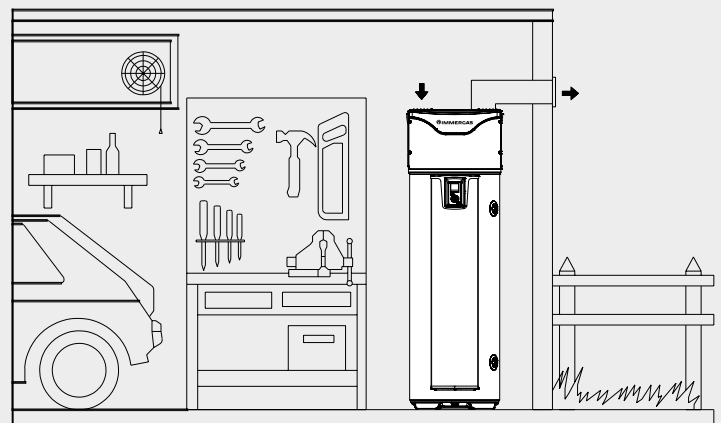

.06 INSTALLATION IN HEATED OR UNHEATED ROOMS, WITH 2 DUCTS FOR THE AIR (INTAKE AND EXPULSION)

Comply the maximum ducts lengths (rif. Instruction manual). It's important to use insulated ducts, to avoid condense in a wet room and use grilles on air-intake and expulsion in order to avoid the entry of foreign bodies.

.06

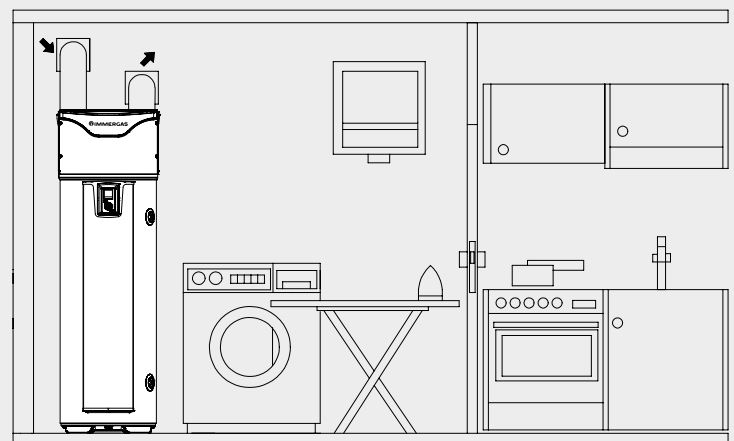

The installation of the heat pump water heater requires a omni-polar circuit-breaker of 16 A and a earth leakage trip of 30 mA not given as standard with RAPAX V2.

Technical characteristics	Unit of measurement	RAPAX 100 V2	RAPAX 300 V2	RAPAX 300 SOL V2
Code		3.028366	3.027346	3.027347
Empty weight (model without coil)	kg	57,0	93,0	108,0
Enamelled steel storage tank capacity	l	100	270	270
Polyurethan insulation tickness	mm	31	40	40
Daily electrical power consumption	kW/h	2,260	6,170	7,160
Domestic hot and cold water hydraulic connections		¾" M	¾" M	¾" M
Coil's heating surface	m ²			1,2
COP (air temperature 15 °C)*		2,75	3,41	3,41
Mixing water maximum quantity (delivery 54 °C)	l	127	341	333
Anticorrosion protection		Magnesium anode	Magnesium anode	Magnesium anode
Water maximum operating pressure	bar	8	8	8
Electrical connection (voltage/frequency)	V/Hz	230/50	230/50	230/50
Maximum total power absorbed by the device	W	1550	2465	2465
Average power absorbed by heat pump	W	250	525	525
Maximum power absorbed by heat pump	W	350	665	665
Power absorbed by auxiliary electrical unit	W	1200	1800	1800
Domestic hot water range by heating pump (52 °C default value)	°C	from 50 to 62	from 40 to 62	from 40 to 62
Heating pump air temperature working range	°C	from - 5 to + 43	from - 5 to + 43	from - 5 to + 43
Heating pump nominal power output (nominal condition 15 °C)	W	870	1650	1650
Air flow (no air ducting)				
Speed 1	m ³ /h	160	300	300
Speed 2	m ³ /h	180	390	390
Load losses acceptable on ventilation circuit, without decrease performance	Pa	25	25	25
Refrigerant gas		R134A	R134A	R134A
Gas refrigerant capacity	kg	0,6	1,35	1,35
Sound pressure at 2 m (no air ducting)	dB(A)	45	47	47
Heating time with heat pump (from 15°C to 51°C - air temperature 15°C)		6h 25'	7h 32'	7h 32'

RAPAX V2 is keeping with 2014/30/UE electromagnetic compatibility directive, 2014/35/UE low tension directive and 2011/65/UE ROHS directive.

* According to EN 16147, water from 10 to 54 °C

RAPAX 300 V2



RAPAX 300 SOL V2



RAPAX 100 V2



Note: The labels are shown in the documentation accompanying the units as well as on the immergas.com website in each product's page.



RAPAX 300 V2/300 SOL V2

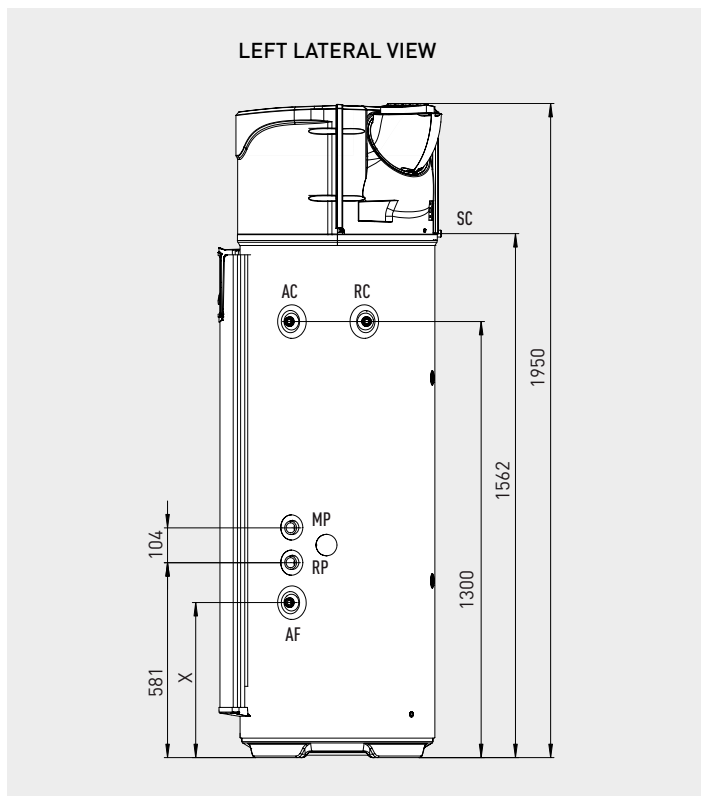

Key

AC	Domestic hot water outlet 3/4" M
AF	Domestic cold water inlet 3/4" M
MP	Delivery solar collector (only RAPAX 300 SOL V2) 1" F
RP	Return solar collector (only RAPAX 300 SOL V2) 1" F
SC	Condensate drain Ø 20
RC	Recirculation 3/4" M (only RAPAX 300 SOL V2)
X	304 mm RAPAX 300 V2; 462 mm RAPAX 300 SOL V2

The use of RAPAX 300 V2/300 SOL V2 involves the installation of an appropriately sized DHW expansion vessel and safety valve, not included in the supply (Immergas supplies a specific option kit, see on the previous page).

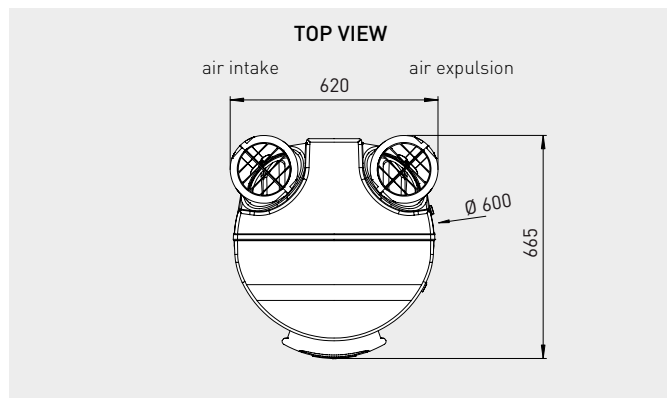

RAPAX 100 V2

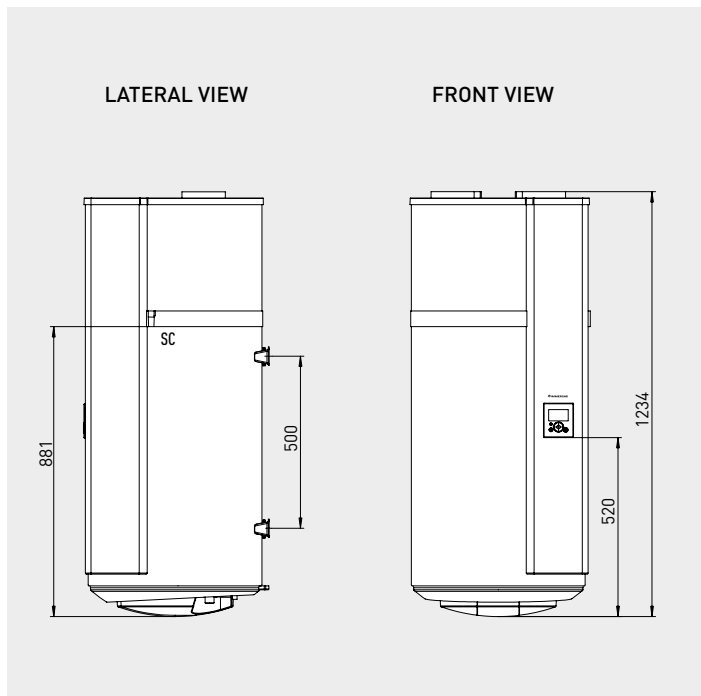

Key

AC	Domestic hot water outlet 3/4" M
AF	Domestic cold water inlet 3/4" M
SC	Condensate drain Ø 20

The use of RAPAX 100 V2 involves the installation of an appropriately sized DHW expansion vessel and safety valve, not included in the supply (Immergas supplies a specific option kit, see on the previous page).

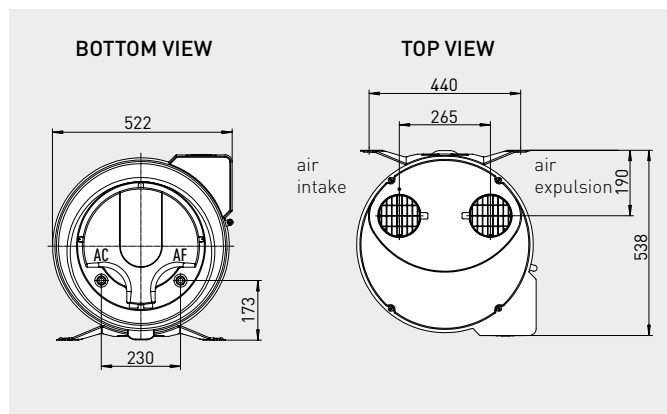

RAPAX 300 V2/300 SOL V2 OPTION KITS

Type	Code
Safety valve 7 bar and 12 litres expansion vessel kit	3.025231
Duct adapter* Ø 160	3.025232
Extension pipe kit Ø 160 0,5 m long *	3.024659
Extension pipe kit Ø 160 1 m long*	3.024516
87° bend kit Ø 160*	3.024517
2 x 45° bend kit Ø 160*	3.024518
Inlet/exhaust pipes insulation kit	3.027545

RAPAX 100 V2 OPTION KITS

Safety valve 7 bar and 5 litres expansion vessel	3.028368
Extension pipe kit Ø 125 0,5 long*	3.016370
Extension tube kit Ø 125 1 m long*	3.016371
Extension tube kit Ø 125 2 m long*	3.015250
Elbow kit Ø 125 to 87 ° *	3.016179
2 x 45° bend kit Ø 125 *	3.016180
Inlet / exhaust pipes insulation kit	3.028371

* The ducts are required to intake and espulsion air on external. Its are not insulated.



Combining the AUDAX and MAGIS PRO ErP range with a heat regulation device is an excellent investment because it improves the seasonal energy efficiency of the heating system. For each of the following heat regulation devices we therefore indicate a class, which gives you the percentage value of increased efficiency.

System controller

Type		Code
<p>Electronic control with microprocessor for integrated systems management. It manages complex systems, for example a boiler, an heat pump and a solar thermal system.</p> <p>Temperature control class VI* o VIII Contribution to seasonal space heating energy efficiency 4%* or 5%</p>	 <p>Dimensions (H x W x D) mm 110 x 105 x 60</p>	3.021522

System controller expansion kit

<p>Connected to system controller, It manages pumps, three way valve, dehumidifier etc. This kit is standard on kit code 3.021527 and 3.021528</p>	 <p>Dimensions (H x L x D) mm 110 x 70 x 60</p>	3.021547
--	--	----------

Remote control kit

<p>Connected to system controller, It manages temperature, humidity and set time.</p> <p>Temperature control class V o VI* Contribution to seasonal space heating energy efficiency 3% or 4%*</p>	 <p>Dimensions (H x W x D) mm 143 x 86 x 36</p>	3.023364
---	--	----------

CRONO 7

<p>Weekly digital chronothermostat</p> <p>Temperature control class IV* or VII Contribution to seasonal space heating energy efficiency 2%* or 3,5%</p>	 <p>Dimensions (H x W x D) mm 103 x 142 x 31</p>	3.021622
---	---	----------

CRONO 7 WIRELESS

<p>Wireless weekly digital chronothermostat</p> <p>Temperature control class IV* or VII Contribution to seasonal space heating energy efficiency 2%* or 3,5%</p>	 <p>Dimensions (H x W x D) mm 103 x 142 x 31</p> <p>Dimensions (H x W x D) mm 82 x 105 x 26</p>	3.021624
--	---	----------

EXTERNAL PROBE KIT

<p>To be connected to MAGIS PRO ErP or system controller code 3.021522 when external probe as standard in outdoor unit is not correctly exposed</p> <p>Temperature control class II*, VI or VII Contribution to seasonal space heating energy efficiency 2%*, 4 or 3,5%</p>		3.015266
---	---	----------

* Temperature control class with default settings. Some heat regulation device can change class depending on the settings and operation modes that can be changed, for example Modulating or ON/OFF. The use of these devices contributes, in percentage, to the seasonal energy efficiency of the heating system.

Temperature/humidity active sensor kit

Type		Code
<p>Connected to system controller, It manages temperature and humidity.</p> <p>Temperature control class V o V*</p> <p>Contribution to seasonal space heating energy efficiency 3% or 4%*</p>	 <p>Dimensions (H x W x D) mm 80 x 127 x 30</p>	3.021524

Room hygrostat

<p>It manages humidity in radiant panel's system</p>	 <p>Dimensions (H x W x D) mm 70 x 115 x 40</p>	3.023302
--	--	----------

CAR^{V2} (modulating remote control)

<p>Modulating thermostat back-light with remote MAGIS PRO ErP controls; can be used also to manage the 2nd zone)</p> <p>Temperature control class V* or VI</p> <p>Contribution to seasonal space heating energy efficiency 3% or 4%*</p>	 <p>Dimensions (H x W x D) mm 103 x 142 x 31</p>	3.021395
---	---	----------

EMR 12 VDC relay kit

<p>Useful to the system controller, to connect DHW resistance/ manage boiler or to activate dehumidifier.</p>		3.023945
---	--	----------

SSR 6 VDC relay kit

<p>Useful to the system controller, to connect heating system resistance</p>		3.023946
--	--	----------

Storage tank NTC probe

<p>Connected to system controller, It manages single zone's flow temperature, and D.H.W. storage tank's temperature. This kit is standard on kit code 3.021527 and 3.021528 and on all Immergas storage tanks except UB 550/750 V2</p>		3.019375
--	--	----------

Solar collector probe

<p>Connected to system controller, It manages solar system</p>		3.019374
--	--	----------

Low temperature safety kit

<p>Low temperature safety kit</p>		3.019229
<p>Low temperature safety kit for kits code 3.021527, 3.021528 and 3.026301</p>		3.013794

2 Relays board kit MAGIS PRO ErP

<p>To manage the dehumidifier</p>		3.026302
-----------------------------------	--	----------

Relay board kit

<p>To be installed inside internal unit, allows interface between zone valves and CAR^{V2}</p>		3.015350
--	--	----------

* Temperature control class with default settings. Some heat regulation device can change class depending on the settings and operation modes that can be changed, for example Modulating or ON/OFF. The use of these devices contributes, in percentage, to the seasonal energy efficiency of the heating system.



HYDRO: Water wall hung split

Through HYDRO it is possible to offer a complete system in all its parts, from the production to the distribution of energy for heating and cooling.



Standard LCD Remote Control

3-way valve as standard, with micro switch for transmitting the request to the hybrid system or the heat pump

Water heat exchanger with a large exchange surface with **condensate drain** and **air vent valve**

Water probe and air probe supplied as standard

Horizontal and vertical directional wind deflectors

Adjustment in cooling and heating with **3 fan speeds plus Auto mode**

Units made of ABS with high mechanical characteristics

Multi-directional piping: left / right / back to satisfy the needs of the different rooms

Technical characteristics	Unit of measurement	HYDRO 3	HYDRO 4
Code		3.027918	3.027919
Dimensions (H x W x D)	mm	290 x 915 x 230	290 x 915 x 230
Weight	kg	13,0	13,3
Heating capacity (Fan speed High/Medium/Low)	kW	3,36 / 3,10 / 2,79	4,37 / 3,73 / 3,17
Cooling capacity (Fan speed High/Medium/Low)	kW	2,63 / 2,41 / 2,16	3,28 / 2,83 / 2,41
Power input (Fan speed High/Medium/Low)	W	24 / 19 / 17	40 / 32 / 28
Water flow rate	l/h	452	564
Water pressure drop heating	kPa	27,3	40,8
Water pressure drop cooling	kPa	29,4	43,5
Air flow (Fan speed High/Medium/Low)	m³/h	425 / 390 / 350	680 / 550 / 460



Note: To know the maximum number of water wall hung splits it is necessary to value the power of the appliance, the flow/rate and pressure losses of the pipes. For further information contact Immegas Customer Service

Stainless steel storage tank units for DHW

Type		Code
UB INOX 120 V2 Equipped with double coil		3.027818
UB INOX 200 V2 Equipped with double coil		3.027819
UB INOX SOLAR 200 V2 Equipped with double coil and built-in solar circuit		3.027820
INOXSTOR 200 V2 Equipped with double coil		3.027748
INOXSTOR 300 V2 Equipped with double coil		3.027746
INOXSTOR 500 V2 Equipped with double coil		3.027747



Zones kit

Type		Code
Distribution manifold kit for 1 direct and 2 mixed temperature zones* (the kit includes an expansion for the system controller for each zone, a 24 vac transformer and an NTC probe for each mixed delivery). Wall-hung or recessed installation		3.021527
Distribution manifold kit for 2 mixed temperature zones (the kit includes an expansion for the system controller for each zone, a 24 Vac transformer and an NTC probe for each delivery. Wall-hung or recessed installation		3.021528
Distribution manifold kit for 1 direct and 1 mixed temperature zones for MAGIS PRO ErP (direct connection, without system controller)		3.026301

* Direct zone means a zone operating at maximum temperature of AUDAX or MAGIS PRO ErP set.

Return temperature increase 3-way valve kit

For system where is necessary to change function (DHW, Heating, etc.)		3.020632
---	---	----------

Expansion vessel kit

12 litres capacity		3.011679
--------------------	--	----------

Connection kit 1"

Connection kit 1" with anti-vibration flexible pipes and shut-off knobs, only for AUDAX		3.025954
---	--	----------

Antivibration support kit

For AUDAX TOP 18/21 ErP		3.027654
-------------------------	--	----------

Integration electric resistance kit for heating system

Integration electric resistance kit for heating system with AUDAX, adjustable on 2, 4 or 6 kW. (only for internal installation). Power supply 230 or 400 Vac		3.021525
Integration electric resistance kit 3 kW for heating system with MAGIS PRO ErP (only to put inside the MAGIS PRO ErP Hydronic unit). Power supply 230 or 400 Vac		3.026300

Additional sanitary electric resistance

Type		Code
Additional sanitary electric resistance 5 kW for UB 1000/1500 V2 and UB 750 V2. Power supply 230 or 400 Vac		3.020862
Additional sanitary electric resistance 2 kW for INOXSTOR 200/300/500 V2 and UB 550/750 V2. Power supply 230 or 400 Vac		3.020861

Wall mounting brackets

For AUDAX or external unit MAGIS PRO ErP		3.022154
--	--	----------

Anti freeze protection kit -15 °C

To protect hydronic unit MAGIS PRO ErP		3.017324
--	--	----------

Connection kit for R410A circuit

The purpose of this kit is to allow an easy connection of the refrigerant circuit, even in the case of pipes coming out from the wall on the hydronic unit MAGIS PRO ErP		3.026089
--	--	----------

Condensate antifreeze heating cable kit

For AUDAX 6/8/12 and external unit MAGIS PRO ErP		3.027385
--	--	----------

Dehumidifier kit



Dehumidifier kit* (only for recessed installation with codes 3.022146 and 3.022147)		3.021529
Dehumidifier back frame kit*		3.022146
Dehumidifier front grille kit*		3.022147

* Useful for radiant systems that work also in cooling.



Buffer tank

The minimum water volume is important mostly for correct defrost cycle functioning. For this reason, the minimum water volumes to ensure are: AUDAX 6 l/kW and MAGIS PRO ErP 7 l/kW for all heating systems. Furthermore it is good to check that the dehumidifiers have at least 3 l/kW (water content in the dehumidifier system circuit).

Type		Code
Horizontal buffer tank with capacity of 25 litres** Dimensions (H x W x D) mm 425 x 910 x 450		3.027842
Horizontal buffer tank with capacity of 75 litres** Dimensions (H x W x D) mm 425 x 910 x 450		3.027843
Horizontal buffer tank with capacity of 100 litres** Dimensions (H x W x D) mm 425 x 1240 x 450		3.027844
Horizontal buffer tank with capacity of 200 litres** Dimensions (H x W x D) mm 821 x 1240 x 450		3.027845
Vertical Buffer tank 50 litres ideal for outdoor installation for coupling with AUDAX 6/8		Dimensions (H x W x D) mm 820 x 360 x 360 3.027539
Buffer tank 75 litres wall-hung or floor-standing installation		Dimensions (Ø x H) mm 512 x 717 3.027288
Wall-hung bracket kit for Buffer tank 75 litres		3.027290

** Is pre-arranged for AUDAX installation on the top of the casing (except 18 and 21 models).



 **IMMERGAS**





App Immergas TOOLBOX



immergas.com

Immergas S.p.A.
42041 Brescello (RE) - Italy
T. 0522.689011
F. 0522.689178

	IMMERGAS IMMERGAS SPA - ITALY CERTIFIED COMPANY UNI EN ISO 9001:2015
Design, manufacture and post-sale assistance of gas boilers, gas water heaters and related accessories	