

GTD Series

Installation, Operation, Maintenance and Parts Manual

CE Certified 230V-50Hz. Infrared Tube Heater.



The GTD Series Infrared Tube Heater is a positive pressure, dual-stage radiant heater system. All persons involved with the installation, operation and maintenance of the heater system must read and understand the information in this manual.

⚠ WARNING



This heater *must* be installed and serviced by a Gas Safe Registered Gas Engineer only! Conversion of the heater for use with other gases must be carried out by a Gas Safe Registered Gas Engineer. Read these instructions carefully before attempting to install, operate or service the heater.



This heater is not approved for use in indoor residential applications and must never be installed indoor in the home. This heater may only be used in outdoor residential applications or indoor/outdoor commercial (or industrial) applications. Installation in residential indoor spaces may result in property damage, asphyxiation, serious injury or death.

In locations used for the storage of combustible materials, signs must be posted to specify the maximum permissible stacking height to maintain the required clearances from the heater to the combustibles. Signs must either be posted adjacent to the heater thermostats or in the absence of such thermostats, in a conspicuous location.

Failure to comply with these warnings and instructions, and those on the heater, could result in personal injury or death.

For Your Safety

If you smell gas:

- Do not try to light any appliance.
- Do not touch any electrical switch.
- Do not use any phone in your building.
- Immediately call your gas supplier from a neighbor's phone.
- Follow the gas supplier's instructions.
- If you cannot reach your gas supplier, call the fire department.

Keep these instructions for future reference.

LIOGTD-Rev. 4809
Print: 2/09-r4_11/7/12(DRP)
Replaces: LIOGTD-2/09(DRP)

Contents

1.0	GTD SERIES TECHNICAL SPECIFICATIONS	3
2.0	SAFETY	4
2.1	Warning Symbols.....	4
2.2	Applications	4
2.3	Codes and Regulations	5
2.4	Clearance to Combustibles.....	6
3.0	INSTALLATION	8
3.1	Design Considerations and Prechecks.....	8
3.2	Recommended Mounting Heights	10
3.3	Hanger Placement and Suspension	11
3.4	Optional U-Bend or Elbow Accessory Configuration	14
3.5	Radiant Tube Assembly	15
3.6	Burner Control Box Suspension	18
3.7	Reflector Assembly.....	19
3.8	Baffle Assembly and Placement.....	21
3.9	Flueing.....	23
3.10	Combustion Air Requirements.....	27
3.11	Gas Supply	29
3.12	Electrical Requirements.....	33
4.0	OPERATION	35
5.0	MAINTENANCE	36
5.1	Troubleshooting Guide.....	37
6.0	PARTS	38
6.1	Burner Assembly Components.....	38
6.1	Tube and Reflector Components.....	39
7.0	GTD Series Kit Contents	40

AVAILABLE MODELS

Model Number	High Fire Rate	Low Fire Rate	Length (Install Kit)			Combustion Chamber	Radiant Tubes
			6M (20-kit)	9M (30-kit)	12M (40-kit)		
GTD-20	20 kW	15 kW	6M (20-kit)	9M (30-kit)	12M (40-kit)	Aluminized	Aluminized or HRT
GTD-25	25 kW	15 kW	6M (20-kit)	9M (30-kit)	12M (40-kit)	Aluminized	Aluminized or HRT
GTD-30	30 kW	20 kW	9M (30-kit)	12M (40-kit)	15M (50-kit)	Aluminized	Aluminized or HRT
GTD-35	35 kW	30 kW	X	12M (40-kit)	15M (50-kit)	Aluminized	Aluminized or HRT
GTD-40	40 kW	30 kW	12M (40-kit)	15M (50-kit)	18M (60-kit)	Aluminized	Aluminized or HRT
GTD-45	45 kW	30 kW	12M (40-kit)	15M (50-kit)	18M (60-kit)	Titanium & Aluminized	Aluminized or HRT
GTD-50	50 kW	35 kW	12M (40-kit)	15M (50-kit)	18M (60-kit)	Titanium & Aluminized	Aluminized or HRT
GTD-55	55 kW	40 kW	15M (50-kit)	18M (60-kit)	21M (70-kit)	Titanium & Aluminized	Aluminized or HRT
GTD-60	60 kW	45 kW	15M (50-kit)	18M (60-kit)	21M (70-kit)	Titanium & Aluminized	Aluminized or HRT

1.0 GTD Series Technical Specifications

Model (Input)	Gas Type	Injector (mm)	Injector Markings (DMS)	Air Inlet Orifice (mm)	Air Inlet Marking	Min. Gas Pressure (mbar)	Max. Gas Pressure (mbar)	High Rate Burner Pressure (mbar)	Low Rate Burner Pressure (mbar)	Baffle Length by Model Length (mm)						Air Proving Set Point (mbar)
										6	9	12	15	18	21	
GTD 20 (20 kW)	G20	3.98	22	36.5	1 7/16	11.5	20	9.0	5.5	3353	3353	2515				0.50
	G25	3.98	22	36.5	1 7/16	15.5	25	13.0	9.0	3353	3353	2515				
	G31	2.48	40	36.5	1 7/16	27.5	37	25.0	15.0	3353	3353	2515				
GTD 25 (25 kW)	G20	4.39	17	39.7	1 9/16	11.5	20	9.0	5.5	4217	3353	2515				0.50
	G25	4.39	17	39.7	1 9/16	15.5	25	13.0	9.0	4217	3353	2515				
	G31	2.70	36	39.7	1 9/16	27.5	37	25.0	15.0	4217	3353	2515				
GTD 30 (30 kW)	G20	4.85	11	41.3	1 5/8	11.5	20	9.0	5.5		4217	2515	1677			0.63
	G25	4.85	11	41.3	1 5/8	15.5	25	13.0	9.0		4217	2515	1677			
	G31	2.94	32	41.6	1 7/8	27.5	37	25.0	15.0		4217	2515	1677			
GTD 35 (35 kW)	G20	5.21	5	44.5	1 3/4	11.5	20	9.0	5.5		4217	3353	1677			0.63
	G25	5.21	5	44.5	1 3/4	15.5	25	13.0	9.0		4217	3353	1677			
	G31	3.04	31	47.6	1 7/8	27.5	37	25.0	15.0		4217	3353	1677			
GTD 40 (40 kW)	G20	5.30	4	44.5	1 3/4	11.5	20	9.0	5.5			3353	2515	1677		0.75
	G25	5.30	4	44.5	1 3/4	15.5	25	13.0	9.0			3353	2515	1677		
	G31	3.45	29	50.8	2	27.5	37	25.0	15.0			3353	2515	1677		
GTD 45 (45 kW)	G20	5.79	1	46.0	1 13/16	11.5	20	9.0	5.5			2515	1677	1677		0.83
	G25	5.79	1	46.0	1 13/16	15.5	25	13.0	9.0			2515	1677	1677		
	G31	3.65	27	50.8	2	27.5	37	25.0	15.0			2515	1677	1677		
GTD 50 (50 kW)	G20	6.14	C	57.2	2 1/4	11.5	20	9.0	5.5			2515	1677	1677	838	1.00
	G25	6.14	C	57.2	2 1/4	15.5	25	13.0	9.0			2515	1677	1677	838	
	G31	3.86	24	57.2	2 1/4	27.5	37	25.0	15.0			2515	1677	1677	838	
GTD 55 (55 kW)	G20	6.75	H	61.9	2 7/16	11.5	20	9.0	5.5				1677	838	838	1.00
	G25	6.75	H	61.9	2 7/16	15.5	25	13.0	9.0				1677	838	838	
	G31	4.08	20	61.9	2 7/16	27.5	37	25.0	15.0				1677	838	838	
GTD 60 (60 kW)	G20	7.03	J	63.5	2 1/2	11.5	20	9.0	5.5				838	838	838	1.13
	G25	7.03	J	63.5	2 1/2	15.5	25	13.0	9.0				838	838	838	
	G31	4.21	19	66.7	2 5/8	27.5	37	25.0	15.0				838	838	838	

All Models:

Gas Connection: ISO-7 BSP

Flue Diameter: 100 mm.

2.0 Safety

The intent of this manual is to provide information regarding general safety, installation, operation and maintenance of this tube heater. You must read and understand all instructions and safety warnings before installing or servicing the tube heater.

⚠ WARNING



Improper installation, adjustment, alteration, service or maintenance can cause property damage, serious injury or death. Read and understand, the installation, operating and maintenance instructions thoroughly before installing or servicing this equipment. Only competent and authorized persons may install or service this equipment and in accordance with relevant clauses of applicable standards and recommendations.

2.1 Warning Symbols

Safety is the most important consideration during installation, operation and maintenance of the tube heater. You will see the following symbols and signal words when there is a hazard related to safety or property damage.

⚠ WARNING

Warning indicates a potentially hazardous situation which, if not avoided, could result in death or injury.

⚠ CAUTION

Caution indicates a potentially hazardous situation which, if not avoided, could result in minor or moderate injury.

NOTICE

Notice indicates a potentially hazardous situation which, if not avoided, could result in property damage.

2.2 Applications

This is not an explosion-proof heater. Consult the local Fire Marshall, fire insurance carrier and other authorities for approval if the proposed installation is in question.

Commercial and Industrial

This tube heater is designed and certified for use in industrial and commercial buildings such as, warehouses, manufacturing plants, aircraft hangars and vehicle maintenance shops.

⚠ WARNING



Not for residential use!

Do not use this heater in the home, sleeping quarters, attached garages, etc.

2.3 Codes and Regulations

The following must be reviewed before installing this heater:

- Check the heater rating label on the heater to verify the proper gas to be used. Check other labels on the heater to verify proper mounting and clearance to combustibles.
- Signs must be posted in storage areas to specify maximum stacking heights allowed in order to maintain published clearances to combustibles.
- Notwithstanding their limited scope, this appliance must be installed in accordance with relevant provisions of the following regulations:

GB - United Kingdom:

Gas Safety (Installation and Use) Regulations 1998 and BS6891:1998. Due account should be taken of any obligations arising from the Health and Safety at Work etc. Act 1974, the current Building Regulations, the current I.E.E. Regulations and other relevant codes of practice.

BS EN 13410:2001

Gas fired overhead radiant heaters “Ventilation requirements for non-domestic premises” should be observed.

IE - Ireland:

I.S.3212:1987, ICP 4, I.S.327. Due account should be taken of any obligations arising for the current Building Regulations, the current I.E.E. Regulations and other relevant codes of practice.

- Under no circumstance is either the gas supply line or the electrical supply line to the heater to provide any assistance in the suspension of the heater.
- The weight of the heater must be entirely suspended from a permanent part of the building structure having adequate load characteristics.
- Neither the gas supply line, electrical supply line or sprinkler heads shall be located within the minimum published clearance to combustibles as shown on page 7.

2.4 Clearance to Combustibles

⚠ WARNING



This is not an explosion-proof heater. Do not store or use flammable objects, liquids or vapor in the vicinity of the heater. Where there is the possibility of exposure to flammable vapors or highly combustible materials, consult the local fire marshal, fire insurance carrier and other authorities for approval of the proposed installation.

⚠ WARNING



This heater should be installed so that the minimum clearances to combustibles, as marked on the heater, will be maintained from vehicles parked below. If vehicle lifts are present, ensure that these clearances will be maintained from the highest raised vehicle.

⚠ WARNING



Fire Hazard. Always maintain published clearance to combustibles. Failure to comply with the stated clearances to combustibles could result in personal injury, death and/or property damage.

Hazards

For maximum safety, the building must be evaluated for hazards before installing this heating system. A critical safety factor before installation is the clearance to combustibles.

Clearances to combustibles is defined as the minimum distance that **must** be maintained between the tube surface or reflector and combustible materials. It also pertains to the distance that must be maintained from moving objects (e.g. overhead doors, cranes, vehicle lifts, etc.) around the tube heater.

The following is a partial list of items to maintain clearances from:

- Gas and electrical lines
- Combustible and explosive materials
- Chemical storage areas
- Areas of high chemical fume concentrations
- Vehicle parking areas
- Vehicle lifts
- Hoists or cranes
- Storage areas with stacked materials
- Lighting
- Sprinkler heads
- Overhead doors and tracks
- Dirty, contaminated areas

If you are unsure about the proposed installation, consult your local fire marshal, fire insurance carrier or other qualified authorities for the approval of the proposed installation.

Safety Signs and Labels

It is important to provide warnings to alert individuals to potential hazards and safety actions. Local codes may require you to post a sign “specifying the maximum permissible stacking height to maintain the required published clearances from the heater to combustibles” near the heater’s thermostat or, in the absence of such thermostats, in a conspicuous location.

All safety labels must be maintained on this appliance. Contact your distributor if replacement labels are needed.

Clearance to Combustibles

IMPORTANT:

For the safe installation of this unit, the clearance to combustibles data below contains clearances that **must** be maintained.

Check the rating plate on the heater to verify the minimum clearance to combustibles and gas type for your model heater.

GTD Series Clearance to Combustibles Data (mm)

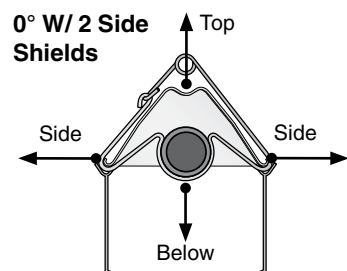
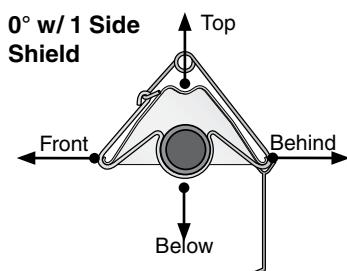
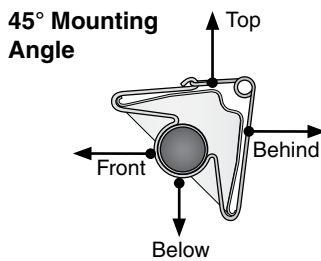
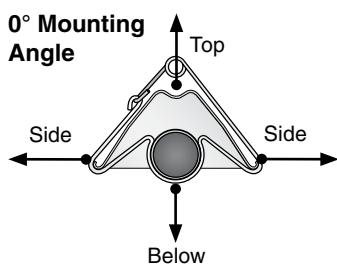

Model No. (kW)	Mounting Angle*	Side		Top	Below	
		Front	Behind			
GTD 20	0°	229	229	152	1524	
	45°	991	203	254	1524	
	w/ 1 side shield	0°	737	203	152	1524
	w/ 2 side shields	0°	229	229	152	1524
6.1m downstream of burner	0°	178	178	152	762	
GTD 25, GTD 30	0°	356	356	152	1676	
	45°	991	203	254	1676	
	w/ 1 side shield	0°	737	203	152	1676
	w/ 2 side shields	0°	406	406	152	1676
6.1m downstream of burner	0°	178	178	152	762	
GTD 35	0°	508	508	152	1930	
	45°	1473	203	254	1930	
	w/ 1 side shield	0°	1067	203	152	1930
	w/ 2 side shields	0°	508	508	152	1930
6.1m downstream of burner	0°	178	178	152	762	
GTD 40, GTD 45	0°	610	610	152	2057	
	45°	1473	203	254	2057	
	w/ 1 side shield	0°	1067	203	152	2057
	w/ 2 side shields	0°	584	584	152	2057
6.1m downstream of burner	0°	279	279	152	1118	
GTD 50	0°	864	864	152	2237	
	45°	1600	203	254	2237	
	w/ 1 side shield	0°	1270	203	152	2237
	w/ 2 side shields	0°	762	762	152	2237
6.1m downstream of burner	0°	279	279	152	1118	
GTD 55, GTD 60	0°	1041	1041	152	2388	
	45°	1600	203	254	2388	
	w/ 1 side shield	0°	1372	203	152	2388
	w/ 2 side shields	0°	762	762	152	2388
6.1m downstream of burner	0°	279	279	152	1118	

* Heaters mounted on an angle between 0° to 45° must maintain clearances posted for 0° or 45° mounting angles; whichever is greater.

3.0 Installation

3.1 Design Considerations and Prechecks

Placement of infra-red tube heaters is influenced by many factors. Aside from safety factors, considerations such as the number of elbows that are allowed, maximum vent lengths, ducting of combustion air and combining vents are a few examples. It is critical that all guidelines and instructions are followed.

To ensure a properly designed heating system, a heating layout should be developed for the correct placement of the burner control box, radiant tubing, venting and combustion air intake ducts. Inspect and evaluate the mounting conditions, vent locations, gas supply and electrical wiring. Refer to the chart below for the recommended distances for the model being installed.

When designing an infrared radiant heating system, consider the following:

- Has the building's heat loss been evaluated?
- Does the design meet the needs of the space?
- Have all clearance to combustible situations been observed?
- Have recommended mounting heights been observed?
- Is the supply (burner) end of the heater located where more heat is required?
- Is it best to offset the heaters and/or rotate the reflectors towards the heat zone?
- Are protective guards, side shields, 'U' or 'L' reflector covers needed?
- Does the heater require outside fresh air for combustion?
- Is the environment harsh or contaminated (requiring outside air for combustion)?
- Are chemicals or vapor a concern (requiring outside air for combustion)?

NOTE: The effective infrared surface temperature of a person or object may be diminished with wind above 8 km/h. The use of adequate wind barrier(s) may be required.

NOTE: When heated, materials high in hydrocarbons (solvents, paint thinner, mineral spirits, formaldehydes, etc.) can evaporate. This may result in odors or fumes being emitted into the environment. To correct this problem, clean the area and/or introduce additional ventilation.

Heaters installed and serviced in accordance with the installation manual do not emit odors into the environment. See notice on page 28 for additional information.

Design Scenario

A tube heater system is being installed in 27.4m (L) x 15.2m (W) space with 4.3m ceilings. Two overhead doors are located at one end and an equipment storage area exists on one side. The calculated heat load is 110 kw.

Figure 3.1 - Poor Design

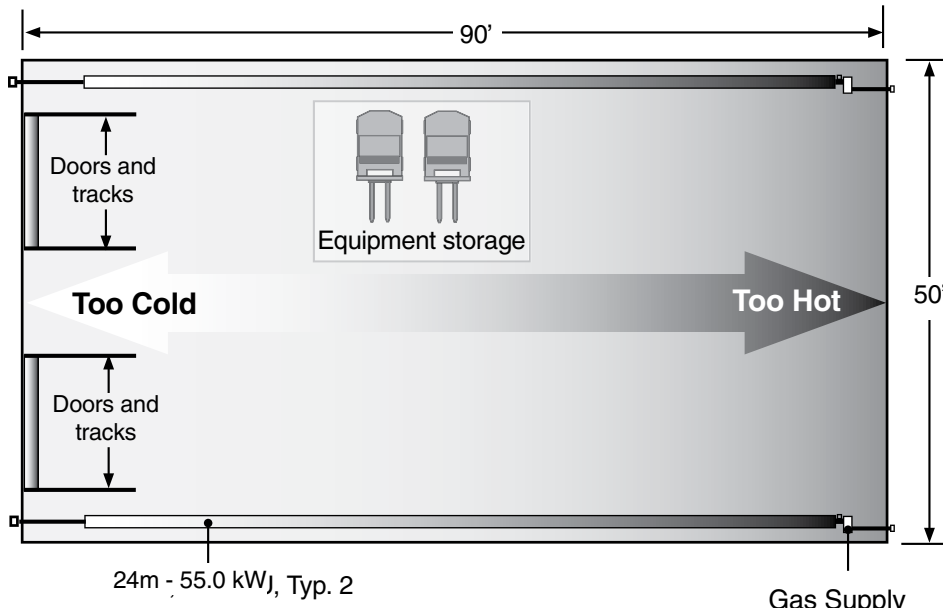

- Two burners (55 kw each) are placed at one end, opposite the area of highest demand (overhead doors).
- Recommended mounting heights are not observed.
- Produces an uneven heat distribution.

Figure 3.2 - Good Design

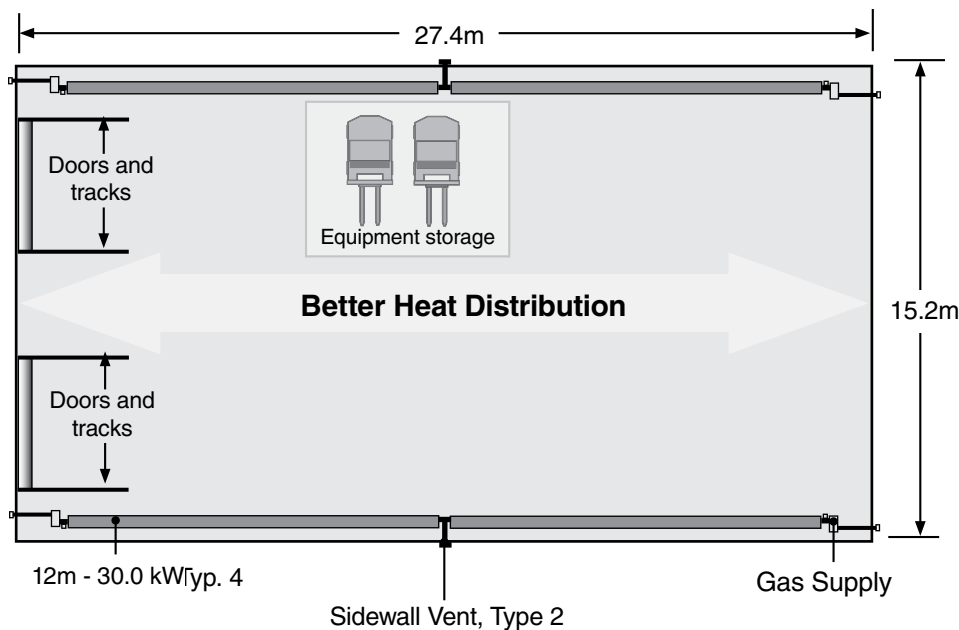

- Four burners (30 kw each) are placed in each corner. Burner (hotter) ends direct heat to areas of highest heat demand.
- Recommended mounting heights observed.
- Distributes heat more evenly.

Design Criteria

3.2 Recommended Mounting Heights

GTD Model Length (M)	kW Range	Recommended Mounting Heights (M)	Coverage Straight Config. (LxW) (M)	Coverage U-Tube Config. (LxW)	Distance Between Heater Rows (M) Dim. A	Distance Between Heater Rows (M) Dim. B	Max. Distance Between Heaters and Wall (M) Dim. C
6M	15 kW	3.0 to 4.6	6.1 x 3.7	3.7 x 3.7	3.0 to 6.1	6.1 to 12.2	4.9
	20-25 kW	3.3 to 6.1	6.7 x 4.6	N/A	6.1 to 9.1	9.1 to 15.2	5.5
9M	15 kW	3.0 to 5.5	9.2 x 4.3	5.2 x 4.0	3.0 to 6.1	6.1 to 12.2	5.2
	20-30 kW	3.7 to 7.0	10.0 x 5.5	5.5 x 4.6	6.1 to 9.1	9.1 to 15.2	6.1
12M	15 kW	3.3 to 5.5	12.2 x 4.9	6.7 x 4.3	3.0 to 6.1	6.1 to 12.2	6.1
	20-35 kW	3.7 to 7.6	13.4 x 6.4	7.0 x 5.2	6.1 to 9.1	9.1 to 15.2	6.1
	40-50 kW	4.6 to 9.2	13.7 x 7.9	7.3 x 6.1	9.1 to 12.2	12.2 to 18.3	7.6
15M	30-35 kW	4.6 to 8.2	16.8 x 7.3	8.5 x 5.8	6.1 to 9.1	9.1 to 15.2	7.6
	40-60 kW	4.9 to 12.2	17.0 x 9.2	8.8 x 7.0	9.1 to 12.2	12.2 to 18.3	7.6
18M	40-60 kW	4.9 to 12.2	20.4 x 10.4	10.4 x 7.9	9.1 to 12.2	12.2 to 18.3	7.6

NOTE: Factory recommended mounting heights are listed as a guideline. If infrared heaters are mounted too low or too high, they may result in heat discomfort or lack of heat. It is generally recommended to observe the recommended mounting heights to optimize comfort conditions. However, certain applications such as spot heating, freeze protection, outdoor patio heating or very high ceilings may result in the heaters being mounted outside of the factory recommended mounting heights. Clearances to combustibles **must** always be maintained.

Figure 3.3 • Recommended Mounting Heights and Distances - see chart 3.2 for dimensions.

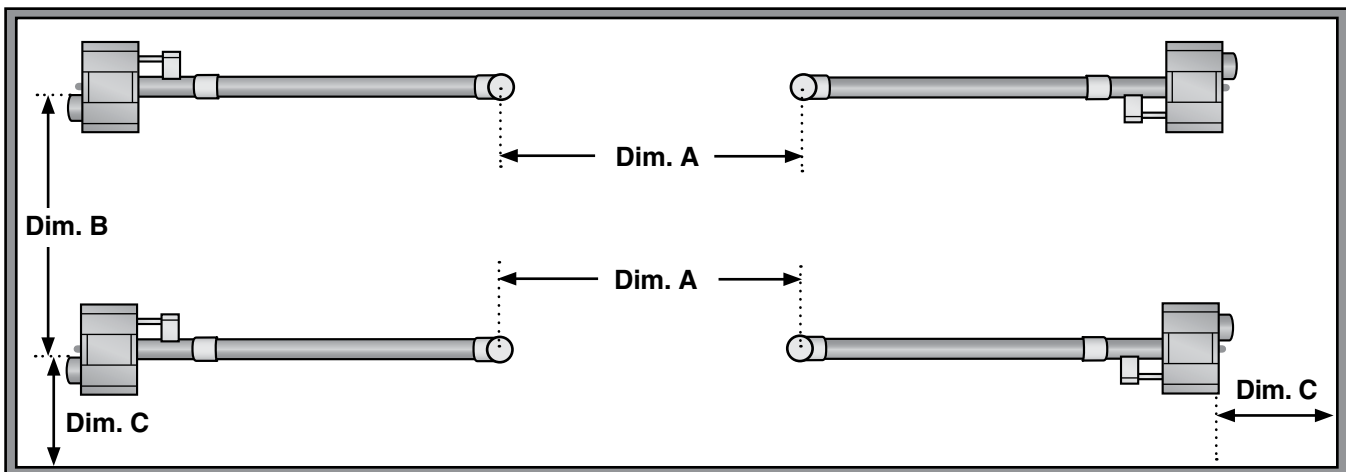

Note: Dimensions A, B & C are based upon heaters hung at the factory recommended mounting height.

3.3 Hanger Placement and Suspension

⚠ WARNING



Improper suspension of the heater may result in collapse and being crushed. Always suspend the appliance from a permanent part of the building structure that can support the total weight and force of the heater.

⚠ WARNING



Failure to maintain the published clearance to combustibles may result in fire and/or explosion, property damage, serious injury or death. Always maintain clearances and post signs where needed.

Suspension of the heater must conform to applicable codes referenced in the Safety section and these instructions.

❶ Lay radiant tubing out in the following order. Position tubes in their approximate locations. Figure 3.4.

- Primary combustion chamber.
- Radiant emitter tubes.

IMPORTANT! 45-60 kW models must use the titanium alloy treated steel combustion chamber as the first tube connected to the burner control box. The combustion chamber has an orange identification sticker located on the swaged end of the tube.

❷ Mark locations for hanging points. Figure 3.4.

NOTE: If the available hanging points do not allow for the recommended spacing (or if an alternative hanging method is utilized) then additional hangers may be necessary.

- The spacing between the burner control box mounting brackets and the first hanger should be approximately 711mm.
- The space between the first two hangers placed on the first tube should be approximately 2692mm.
- The space between hangers thereafter, one per tube, should be approximately 2946mm.

Hanger Placement and Suspension

Figure 3.4 • Heater Suspension Layout

NOTE:

A sticker identifying the combustion chamber(s) is located on the swaged end of the tube(s).

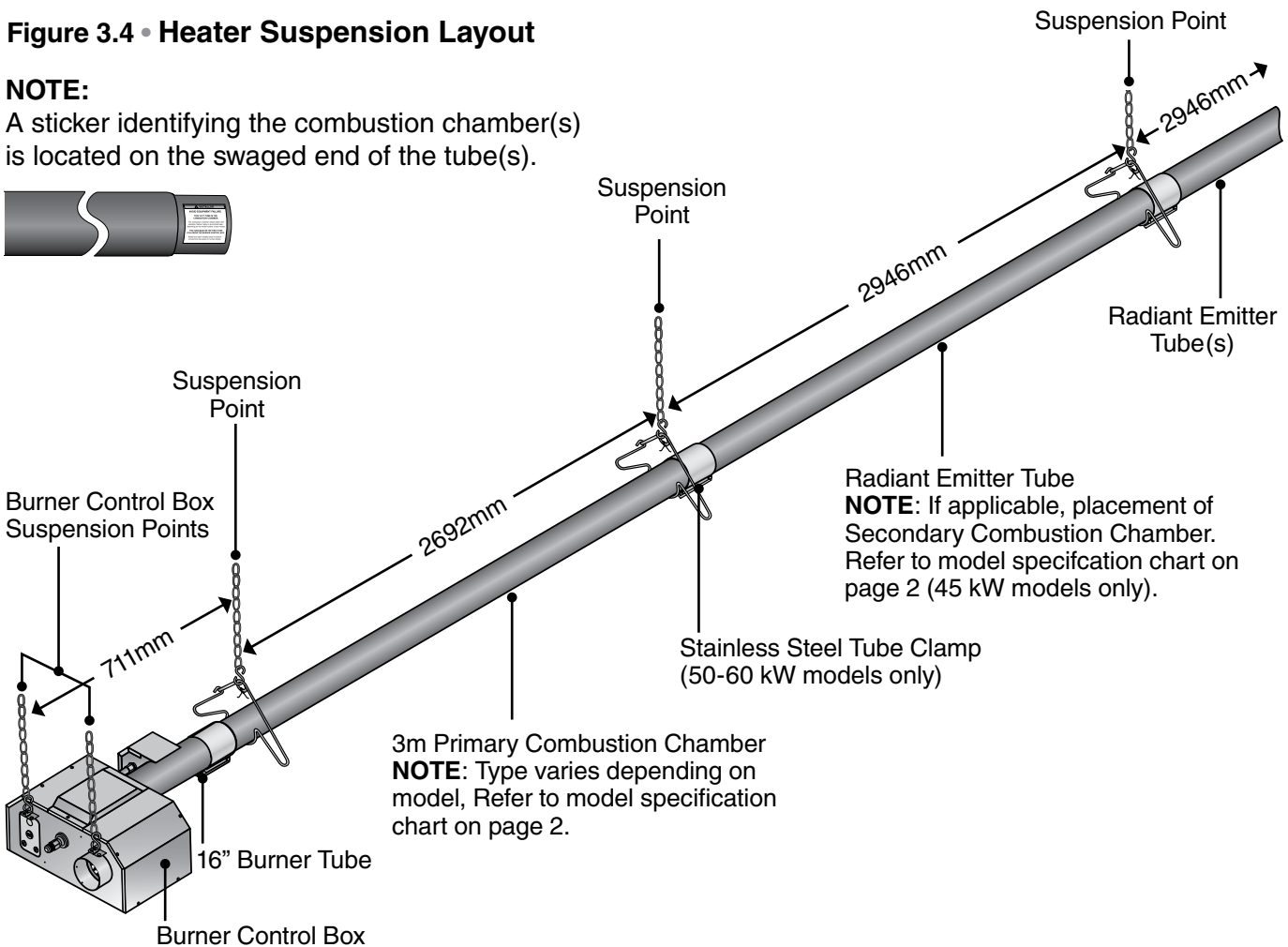

Heater Mounting Requirements and Weights

GTD Model Length (M)	Dimension Straight Config. (mm)	Tube & Reflector Suspension Points	Control Box Stabilizer	Shipping Weight (kg)	Stainless Steel Ship Weight (kg)	Chain Set Qty. Straight Config.	Chain Set Qty. U-Tube Config.	Optional Brass Knuckles (P/N: BK)	Optional Single Mount Bracket (P/N: SMB) U Config. Only.
6M	6580	3	2	54.5	66.0	5	6	3	2
9M	9530	4	2	73.0	88.5	6	7	4	3
12M	12470	5	2	86.5	107.0	7	8	5	3
15M	15420	6	2	107.0	132.0	8	9	6	4
18M	18360	7	2	102.5	150.0	9	10	7	4

Hanger Placement and Suspension

Suspension of the heater must conform to applicable codes referenced in the Safety section and these instructions.

- ③ Prepare the mounting surface, if necessary, such as: weld blocks, drill holes. Figure 3.5.
NOTE: The burner control box and radiant tubes should be in straight alignment and level.
- ④ Fasten beam clamp, screw hook or other type of suspension anchor to hanging point.
- ⑤ Attach and close S-hook and #1 double-loop chain to anchor. Check that it is securely attached.
NOTE: Threaded rod and turnbuckles may be used.
- ⑥ Attach hangers to chains. Adjust chain lengths until radiant tubing is level and equal weight distribution is achieved. **NOTE:** Chains must be straight up and down. Do not install chains at an angle as this can result in tube warpage or separation.

Figure 3.5 • Mounting the Hangers

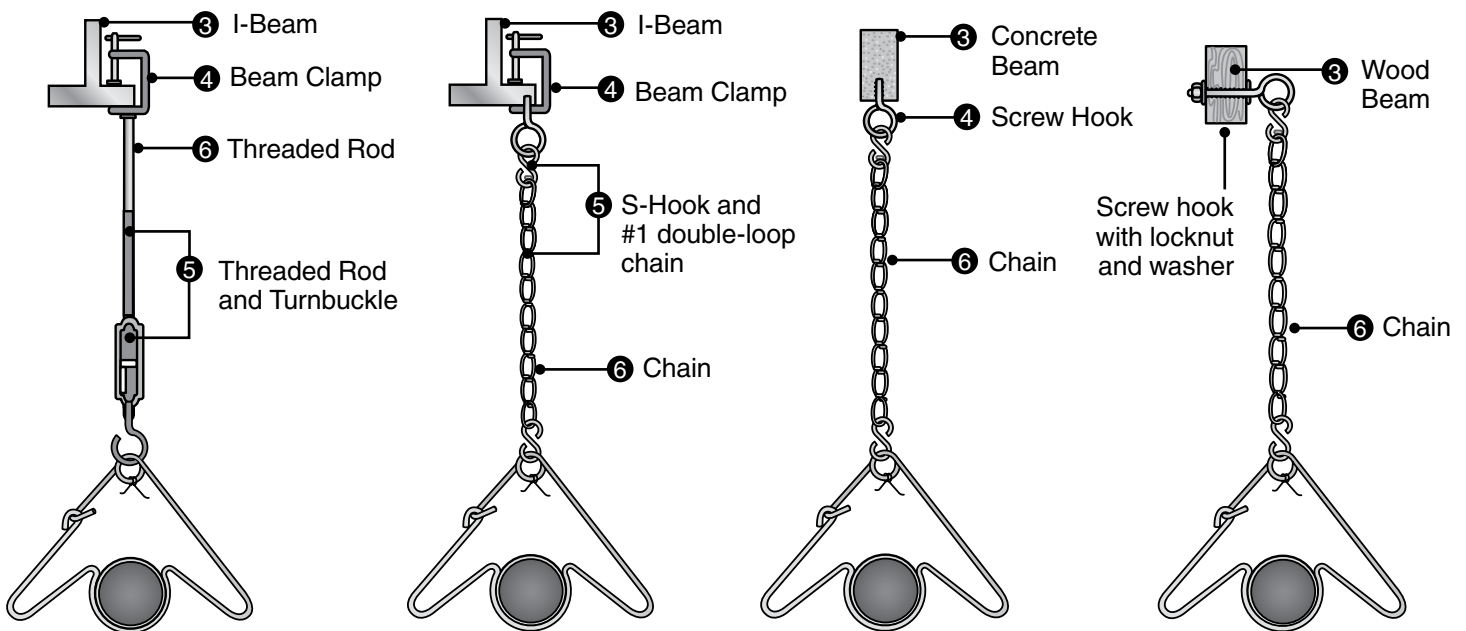

3.4 Optional U-Bend or Elbow Accessory Configuration

Figure 3.6 • U-Tube Hanger Mounting Options

NOTE: 9M and 15M models require 5EA-SUB accessory package when installing in a 'U' configuration

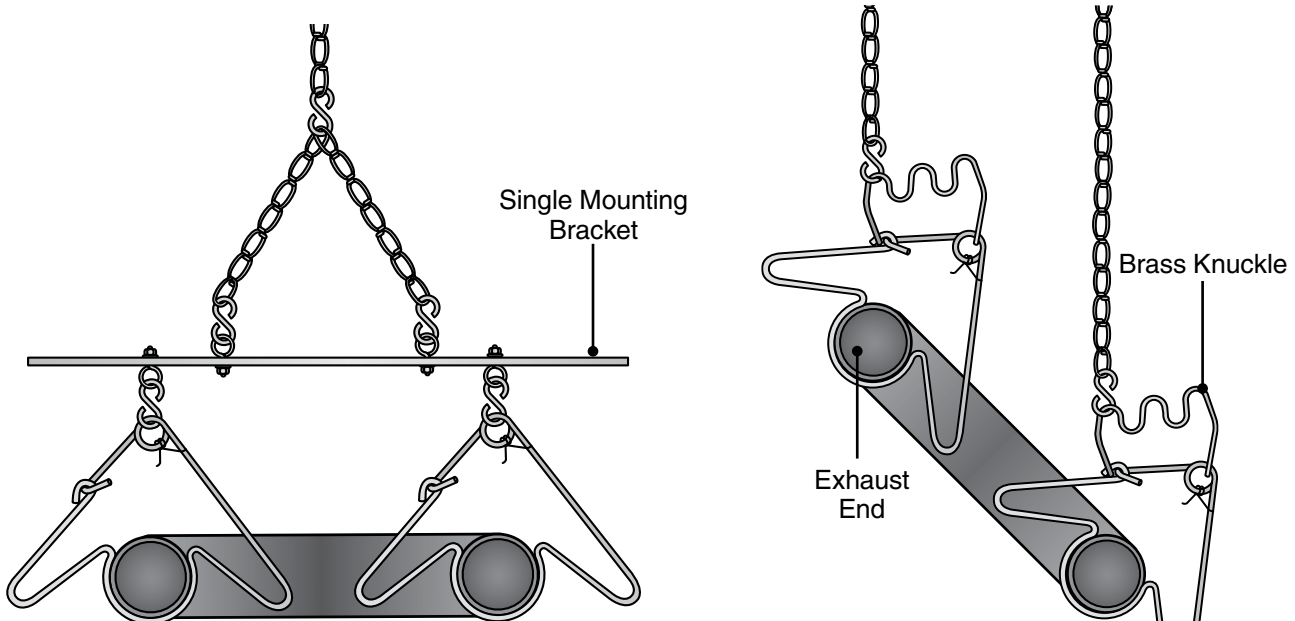

U-Tubes can be mounted from a single suspension point using a Single Mounting Bracket (P/N: SMB) with five S-hooks and #1 double-loop chains.

U-Tubes can be mounted at a 15, 30 or 45 degree angle with two suspension points, using two Brass Knuckle (P/N: BK) fittings, #1 double-loop chains and S-hooks.

Figure 3.7 • Angled Hanger Mounting Options

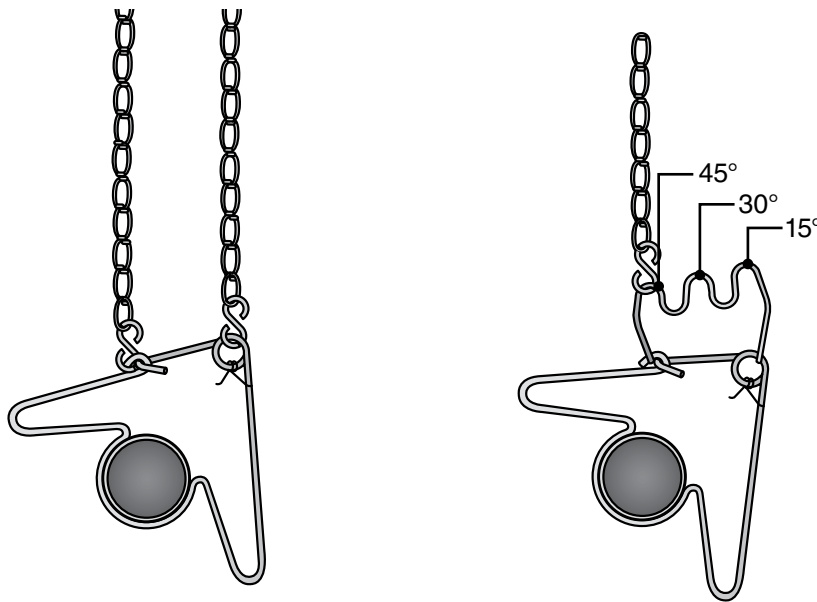

For 45 degree hanging angle use two S-hooks and two #1 double-loop chains.

For variety of hanging angles, use the Brass Knuckle (P/N: BK) fitting with a #1 double-loop chain and S-hook.

3.5 Radiant Tube Assembly

To install the radiant tubes:

- 1 Place tubes in hangers with the welded seam facing downward and the swaged end of the tube towards the exhaust end of the heater system (see Figure 3.8).

Refer to section 3.8 on page 21 for tube installation sequence.

Figure 3.8 • Attach Hangers

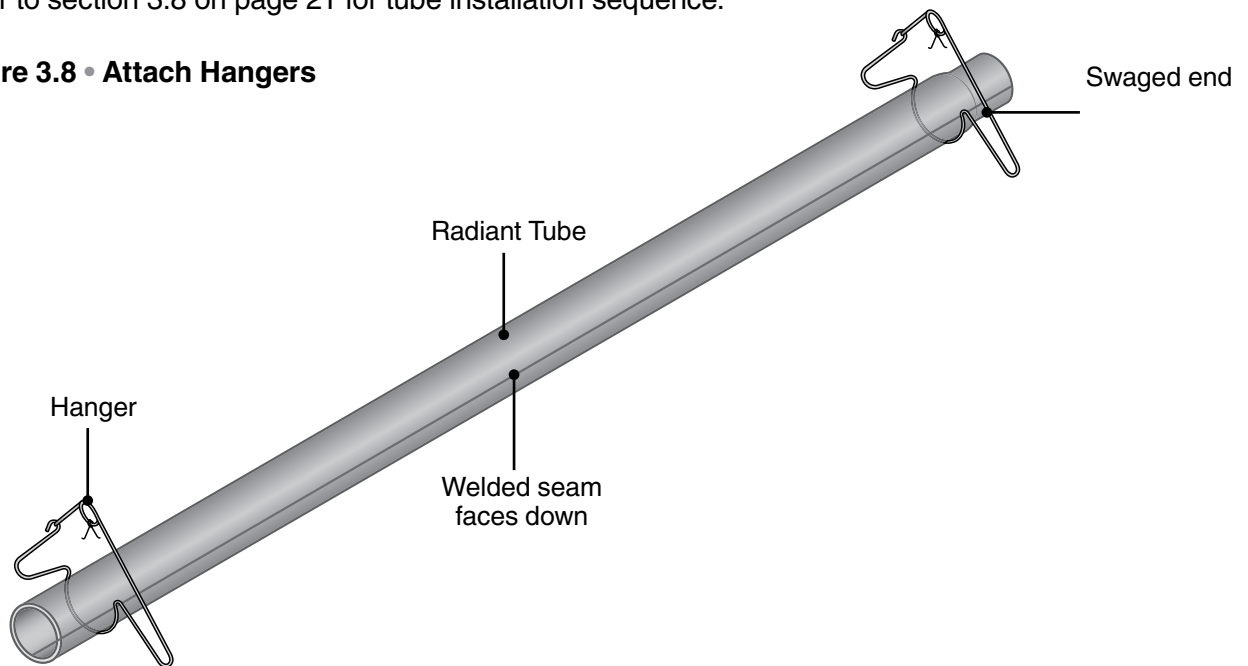

- 2 Slide tube clamps onto radiant tubes (see Figure 3.9).

Figure 3.9 • Attach Tube Clamps

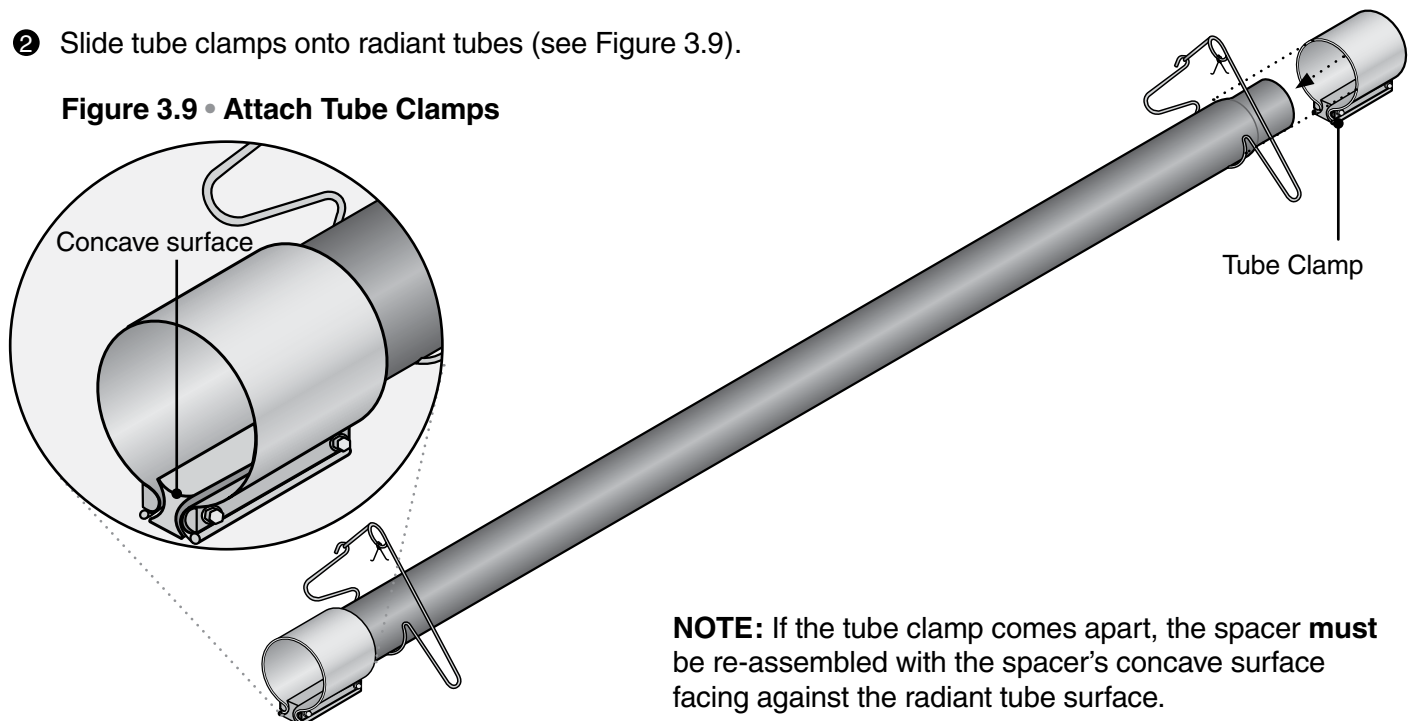

Radiant Tube Assembly

- ③ Slip-fit the radiant tube sections together until tightly connected (install swaged end of each tube towards exhaust end). **NOTE:** If it is difficult to mate the tubes, they may be installed incorrectly.
- ④ Center tube clamps over the seams where two radiant tube sections connect. If necessary, rotate tube clamps so they will not interfere with the reflector end caps during expansion and contraction of the heater while operating.
- ⑤ Tighten tube clamp bolts to secure. When proper compression is obtained (30-44 Nm), the tube seam will create a visible mark on the tube clamp. **NOTE:** Excessive torque may damage the tube clamp.
- ⑥ Determine the location of the burner control box and note the placement of the mounting chains.

Figure 3.10 • Tube Connections

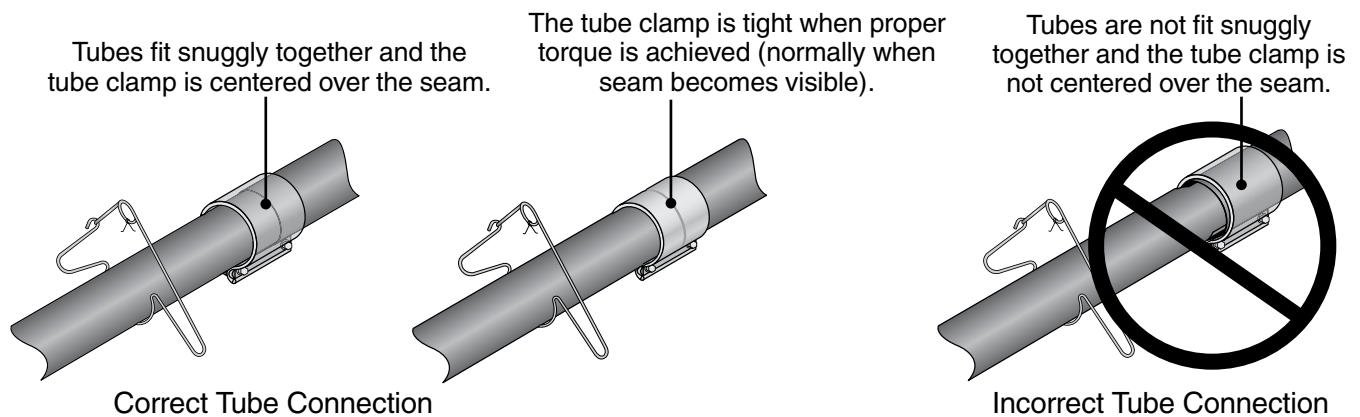

Optional U-Bend or Elbow Accessory Configurations

A 180 degree U-bend or 90 degree accessory fitting may be installed in the radiant tube heater system. Refer to page 17 for minimum distance requirements from the burner control box.

When installing a U-bend or Elbow Accessory Fitting:

- The top clearance of an uncovered (no reflector) U-bend or elbow accessory fitting to combustibles is 458mm.
- If operating the heater un-vented, separate the intake air to the heater from its exhaust products a minimum of 1220mm; further separation may be necessary (see figure 3.12). Outside combustion air may also be supplied.
- A maximum of one 180° U-bend or two 90° elbows can be installed on a heater.
- Omit one 840mm section of turbulator baffle. Refer to Baffle Assembly on pages 21 & 22.

Figure 3.11 • Optional Tube Connections

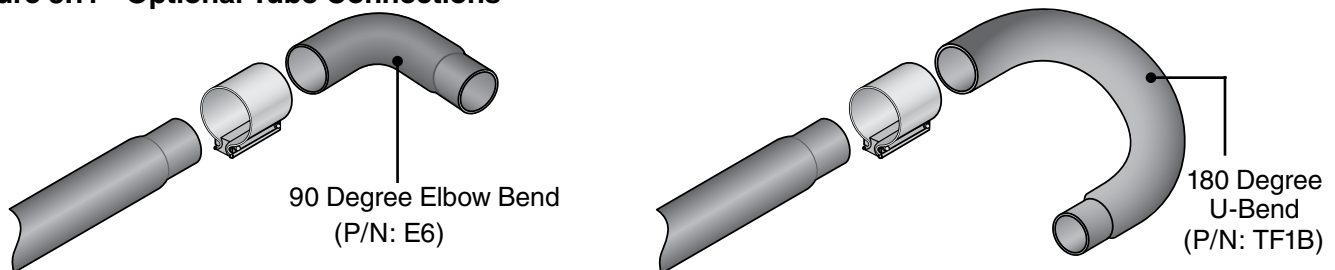

Radiant Tube Assembly

Figure 3.12 • Elbow and U-Bend Clearances

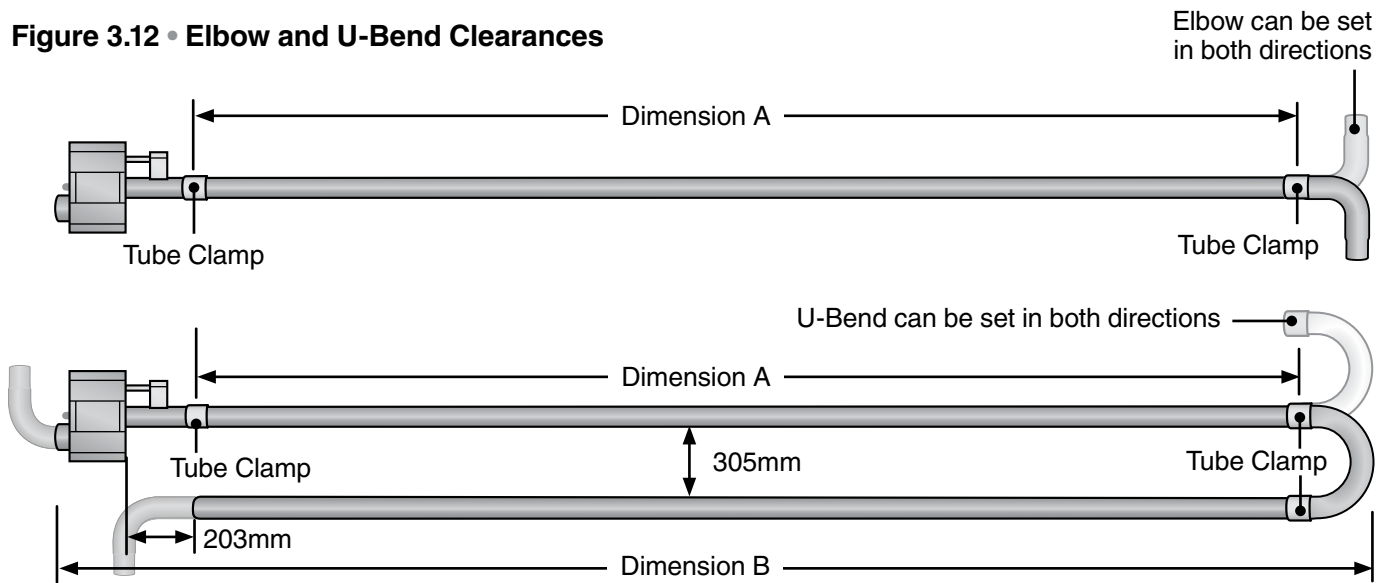
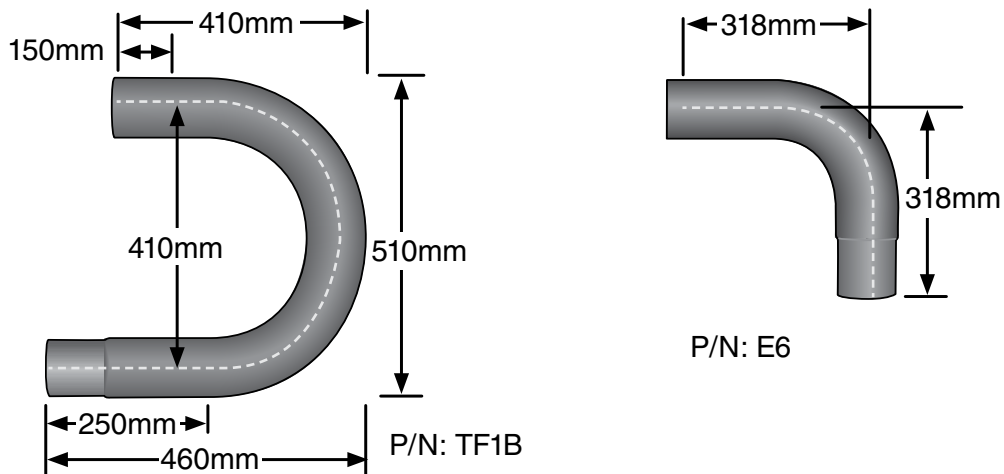

Figure 3.13 • U-Bend and Elbow Dimensions



Minimum Distance from Burner Control Box to U-Bend or Elbow Accessory

GTD Model Input (kW)	Dimension A (mm)
GTD 20	3050
GTD 25, 30	3050
GTD 35	4570
GTD 40, 45	6100
GTD 50	7620
GTD 55, 60	7620

Overall Dimensions for Heaters Configured with U-Bend (P/N: TF1B)

GTD Model Length	Dimension B (mm)
6M	3963
9M	5385
12M	6909
15M	8332
18M	9856

3.6 Burner Control Box Suspension

Suspending the burner control box must be done in accordance with applicable codes listed in the Safety section and these instructions.

The burner control box must be in straight alignment with radiant tubes and level. Contact your local distributor or the factory to see if your application allows for the rotation of the burner control box.

- ❶ Determine the mounting chain locations for hanging the burner control box.
- ❷ Fasten beam clamp, screw hook or other type of suspension anchor to hanging point.
- ❸ Attach S-Hook and #1 double loop chain (P/N: THCS) to anchor. Check that it is securely connected.
- ❹ Attach chain assemblies and S-Hooks to mounting brackets on the burner control box. Adjust chain lengths until level and in straight alignment with radiant tubes. Burner sight glass will be visible from the floor.

Figure 3.14 • Burner Control Box Assembly • Side View

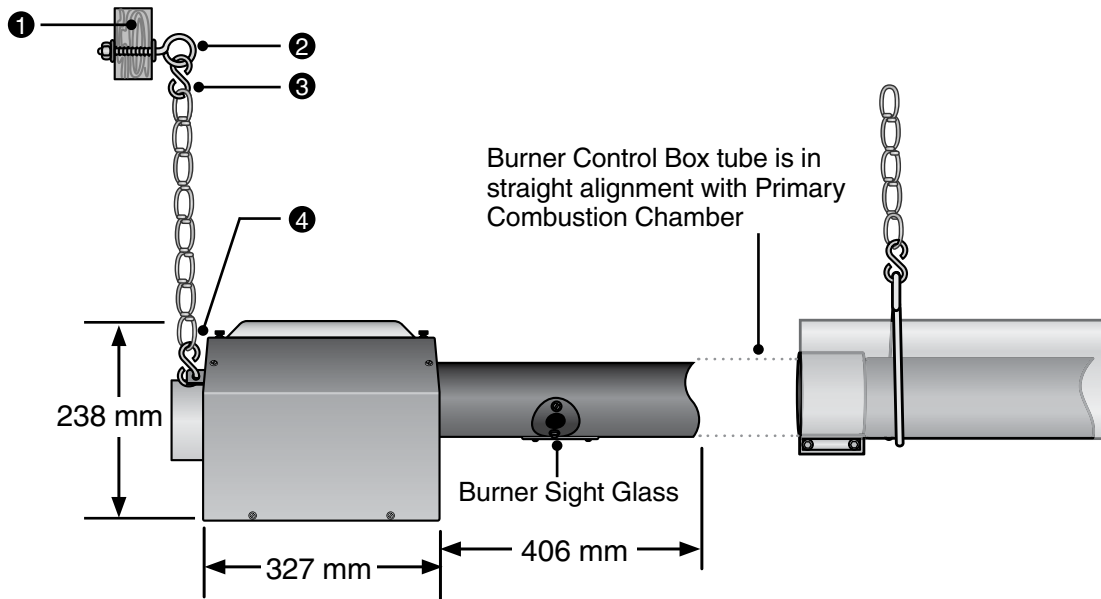
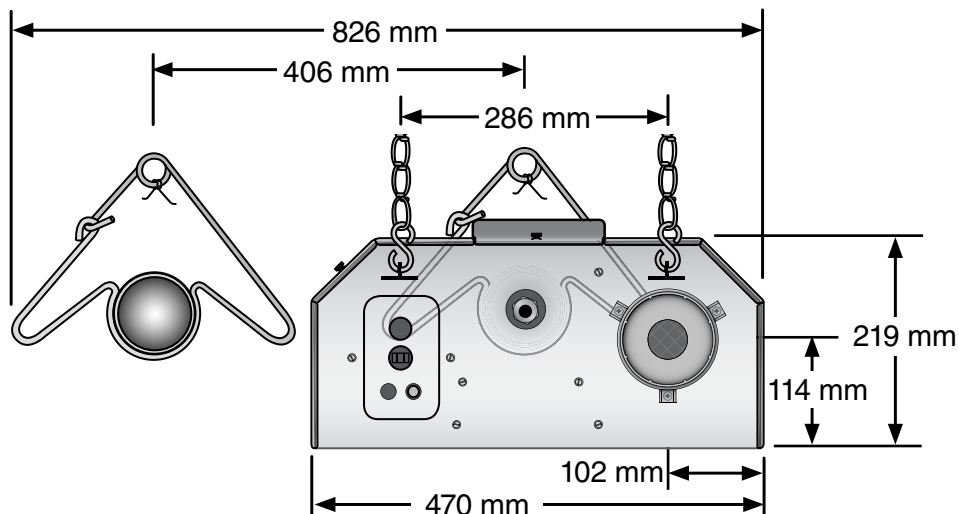

Figure 3.15 • Burner Control Box with U-Bend • End View



3.7 Reflector Assembly

To install the reflectors:

- ❶ Attach reflector center supports onto radiant tubes.
- ❷ Slide each reflector section through the hangers and adjust the reflector tension spring into the V-groove on the top of the reflector. The reflectors should overlap approximately 102mm.
- ❸ To prevent the reflectors from shifting, secure the reflector sections together using sheet metal screws except at the expansion joint (see page 21). **NOTE:** Installer to provide sheet metal screws.
- ❹ Attach reflector end caps, with polished side inward, to each end of the reflector run.

Reflectors, and reflector accessories, direct infrared energy to the floor level. The reflector assembly depends on the heater configuration, proximity to combustibles and the space surrounding the heater. Before you begin assembly, determine if the use of reflector accessories are necessary (see page 20).

Figure 3.16 • Reflector Assembly

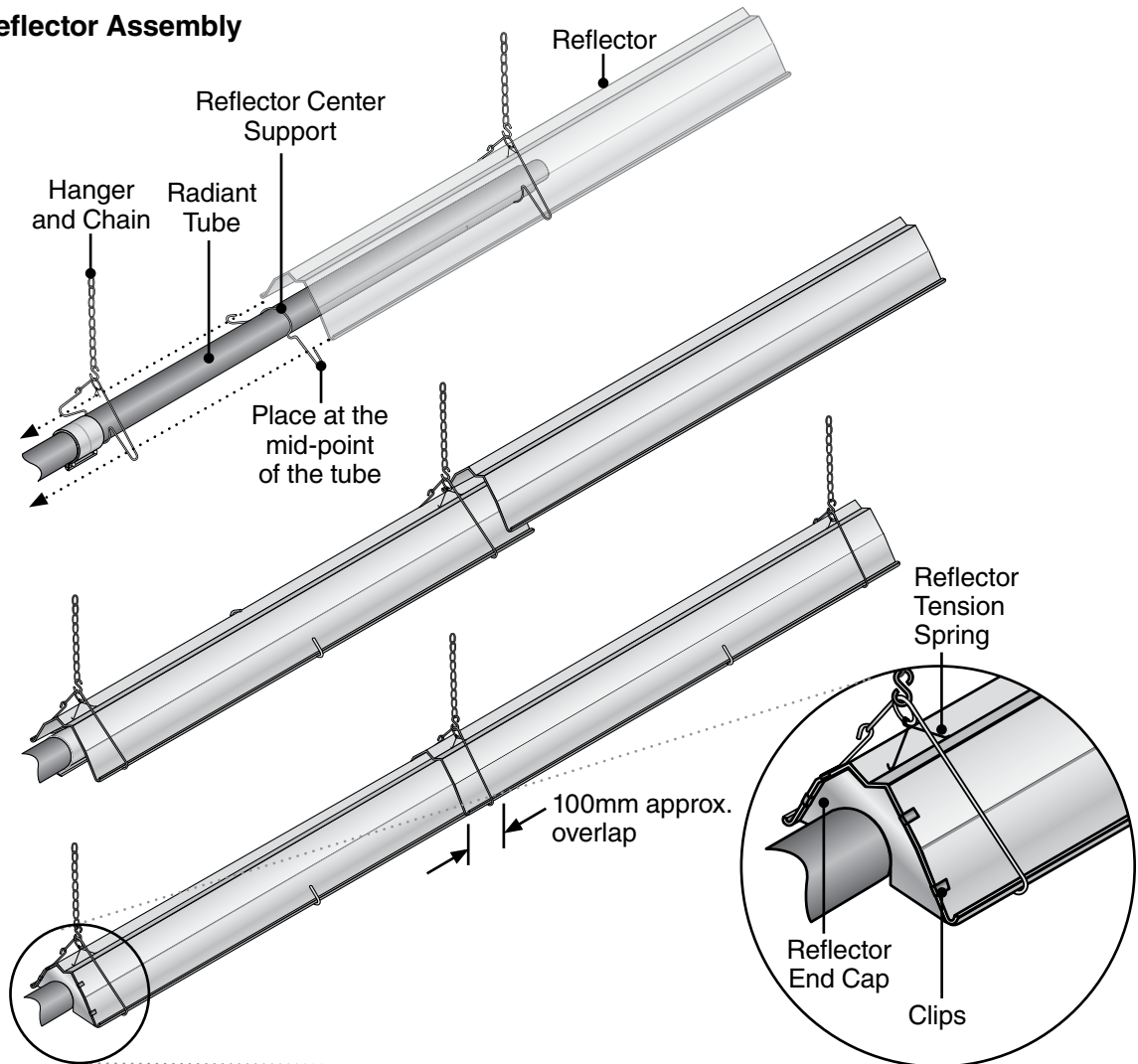

Reflector Assembly

Common Optional Accessories

Reflector Accessories	Description	Part #
Elbow Reflector*	90° bend, highly polished aluminum reflector elbow. Designed to fit atop one elbow accessory fitting.	RE
U-Reflector*	180° bend, highly polished aluminum reflector U-bend. Designed to fit atop one U-bend accessory fitting.	RU
Side Shield Reflector *^	Highly polished side shield extension used to direct infrared rays downward, away from side walls and combustibles.	SSE
Protective Guard	Used to prevent debris or objects from becoming lodged between the radiant tube and reflector. Required when mounting below 2438 mm.	PG

* Reflectors cannot be rotated when used with this accessory.

^ Refer to the Clearance to Combustibles chart on page 7 for minimum distances to combustibles when side shield extension(s) are used.

Figure 3.17 • Reflector Shield Accessories

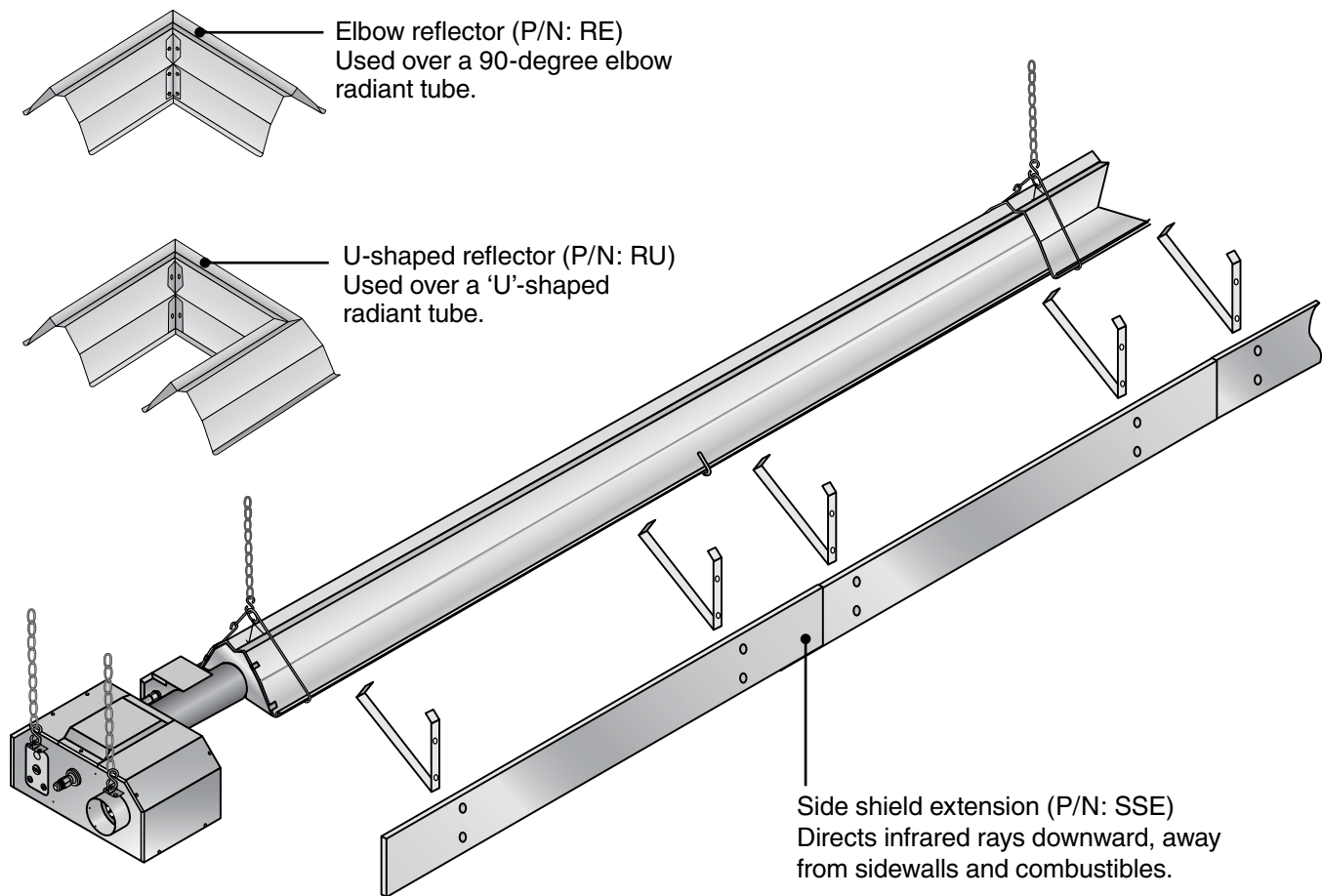







3.8 Baffle Assembly and Placement

Secured Joints and Baffle Location for Reflectors

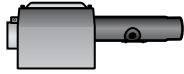
NOTICE

Different inputs and models utilize different baffle lengths. Remove all enclosed baffle sections from box and retain with applicable heater. Reference shipping label for proper baffle size.

Each 840mm baffle section must be assembled with other baffles and placed in the radiant tube section furthest from the burner. **Important:** Omit one section of baffle if heater is configured with a U-bend or Elbow accessory fitting.

Key	
	Burner Control Box with Burner Tube
	Expansion joint on Reflectors
	Secured joint on Reflectors [^]
	Primary Combustion Chamber Tube with clamp
	Radiant Tube with clamp
	Baffle location

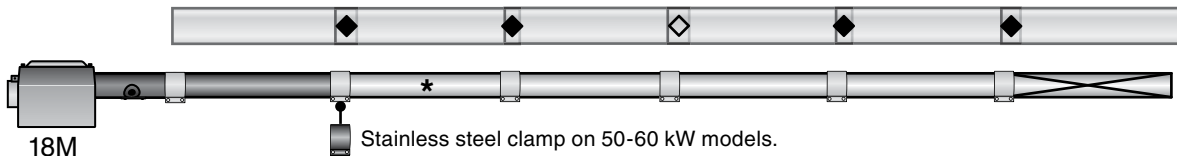
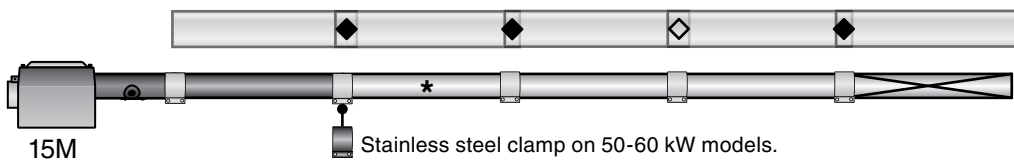
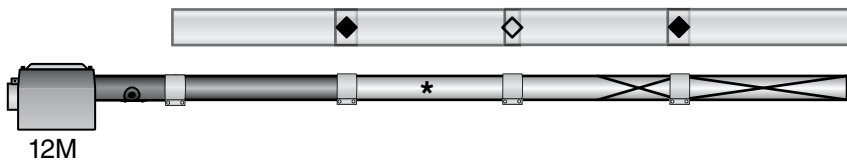
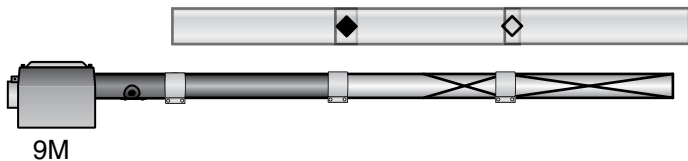
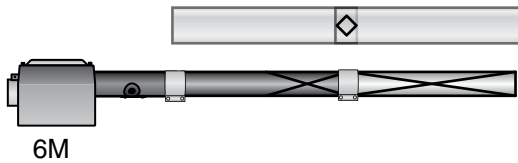

* 45 to 60 kW models utilize a secondary aluminized steel combustion chamber placed immediately downstream of the primary combustion tube.

[^] When heaters configured with a U-shaped accessory fitting (TF1B), the location of the reflector expansion joint differs from that shown at left. Ensure allowance for expansion on the primary leg of the U-tube installation.

Baffle Assembly and Placement

To assemble the baffles: **NOTE:** Baffles may be inserted into the tube while being assembled.

- 1 Determine the number of baffles needed for your model number. Remove one 840mm baffle section if heater is installed with an elbow or U-bend accessory.
- 2 Install the baffle tabs at a 90° angle to the baffle keyhole (see Figure 3.18).
- 3 Insert one baffle tab into keyhole and slide completely to one side until both baffle tabs appear in the keyhole.
- 4 Adjust the tabs to the center of the keyhole and rotate the baffle 90 degrees to lock the baffle sections together.
- 5 Repeat this process with remaining baffle sections to complete assembly.

Figure 3.18 • Assembling the Baffles

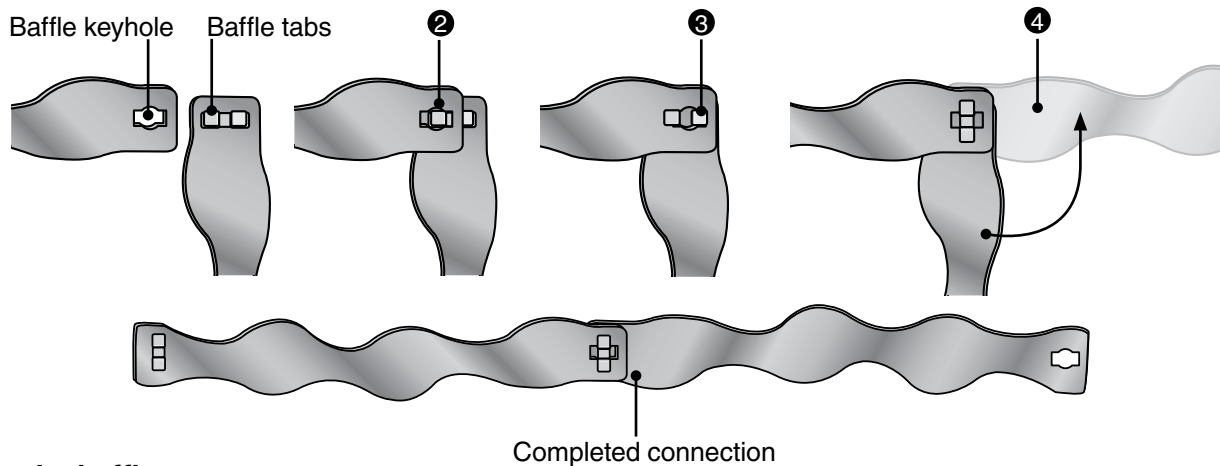

To insert the baffles:

- 1 Insert baffles with the keyhole end first.
- 2 Rotate baffle assembly so that it is in the **vertical position**.
- 3 Slide baffle assembly into the last radiant tube section, furthest from burner control box.
NOTE: Baffle assemblies longer than 3048mm will continue to be fed into next tube section.

Figure 3.19 • Inserting the Baffles

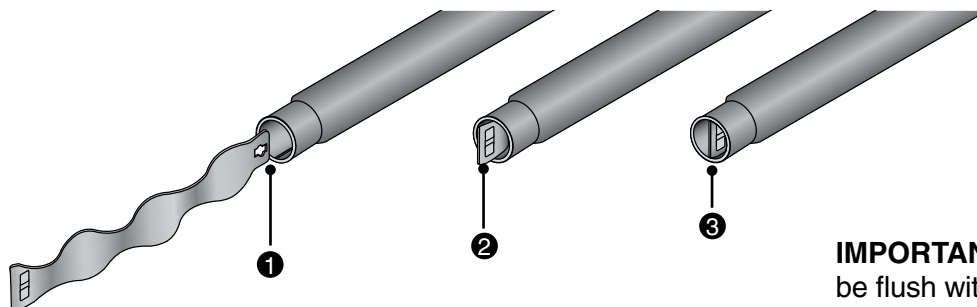

IMPORTANT: Baffle assembly must be flush with the end of the last tube section and in the vertical position.

3.9 Flueing

WARNING



Insufficient flueing and/or improperly sealed flues may release gas into the building which could result in health problems, carbon monoxide poisoning or death.

Improper flueing may result in fire, explosion, injury or death.



Seal flue pipes with high temperature sealant and three (3) sheet metal screws. Flue enclosed spaces and buildings according to the guidelines in this manual and applicable national, state, provincial and local codes.

The heating system may operate either flued or un-flued (see page 27). Flueing can terminate through the sidewall (horizontal) or the roof (vertical) and be individually or commonly flued.

Follow these guidelines and all applicable codes for all models, prior to installing flue material. Local codes may vary. Refer to current I.E.E. Regulations and other relevant codes of practice.

Flueing Requirements

- Seal single skin flue with high temperature sealant and three (3) sheet metal screws.
- Single skin galvanized flue pipe must be insulated in cold environments.
- Do not use more than two 90 degree elbows in the exhaust flue.
- To maintain clearances to combustibles, the use of an approved wall or roof thimble and twin skin flue is required for the portion of flue pipe that runs through combustible material in the building wall or roof (see Figures 3.20 & 3.21).
- The maximum flue length is 6100mm.

Flue Assembly

Figure 3.20 • Flue Requirements:

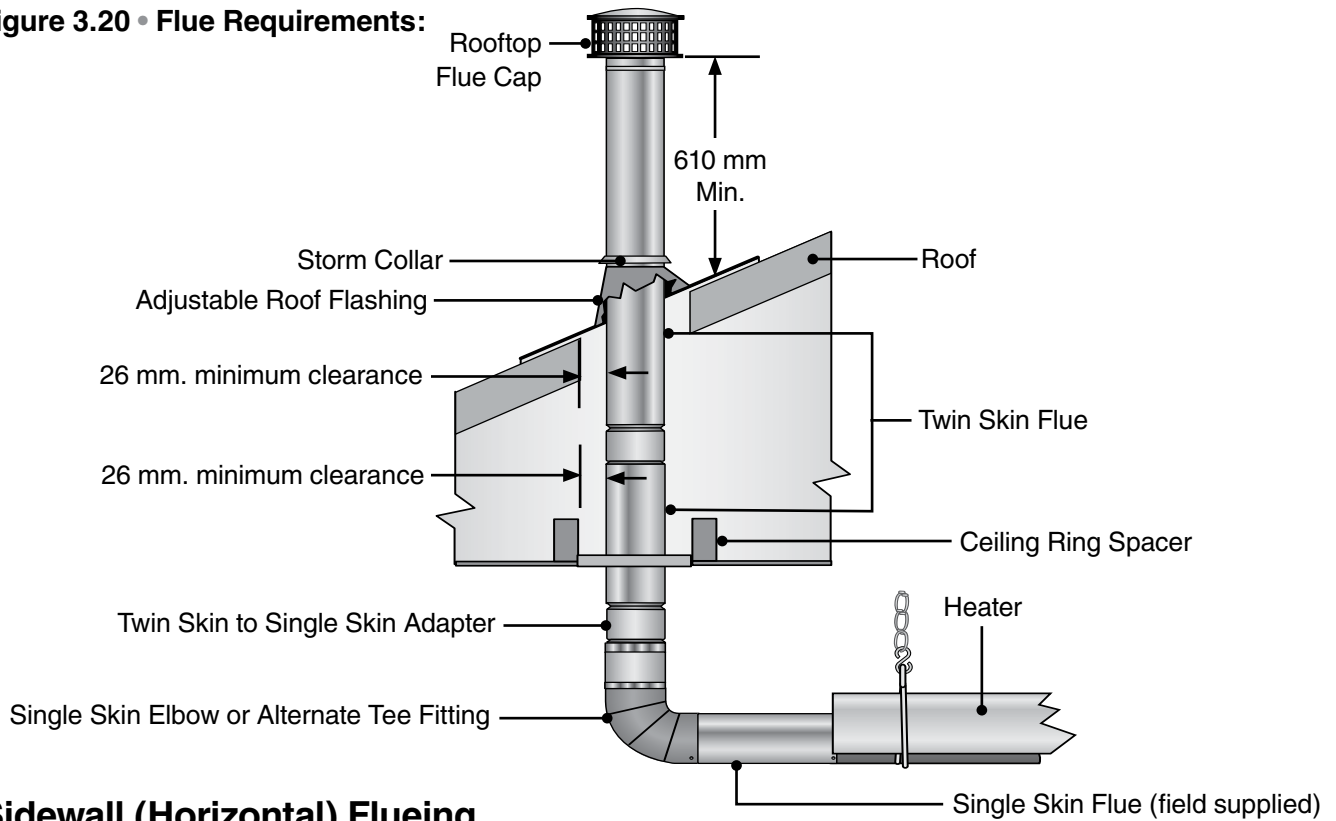

Sidewall (Horizontal) Flueing

Guidelines:

- To prevent moisture from entering the heater system, slope the flue pipe down toward the outlet 20mm. per meter of flue length. **Do not** pitch the heater.
- Flue must extend beyond any combustible overhang.

Figure 3.21 • Vent Slope - Side View

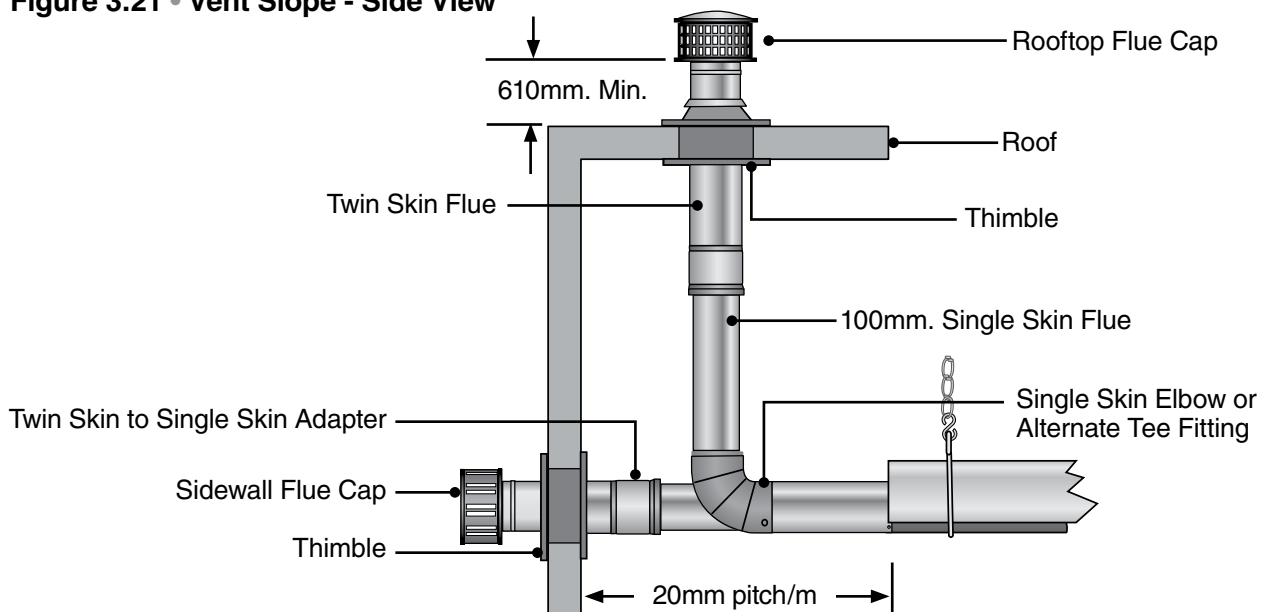

Flue Assembly

Flue Termination

- Flue must terminate a minimum of 1200mm below, 1200mm horizontally from or 300mm above any window or door that may be opened and gravity air inlet into the building.
- Flue must terminate a minimum of 900mm above any forced air inlet that is located within 3100mm.
- The bottom of the flue terminal must be located a minimum of 300mm above grade level and must extend beyond any combustible overhang. Vents adjacent to public walkways must terminate a minimum a 2100mm above grade level.
- The flue terminal must be installed to prevent blockage by snow and protect building materials from degradation by flue gases.
- The flue cap must be a minimum of 152mm from the sidewall of the building.
- Flues must extend beyond any combustible or be a minimum of 915mm below a combustible overhang.

Roof (vertical) Flueing

Guidelines:

- Separate air intake duct from flue pipe a minimum of 1200mm by placing flues pipes higher than adjacent air intake duct.
- Flueing may utilize standard twin skin cap.
- The flue terminal must extend a minimum of 610mm above the roof.

Figure 3.22 • Vertical Flueing - Side View

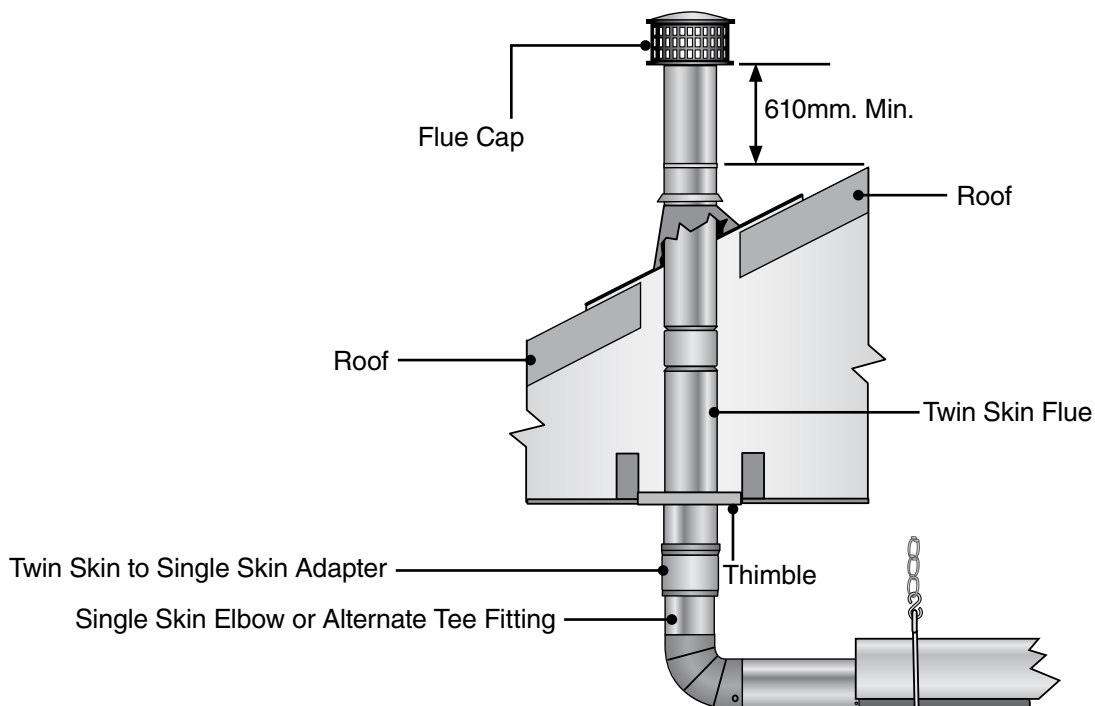

Flue Requirements

Figure 3.23 • Sidewall Flueing - Side View

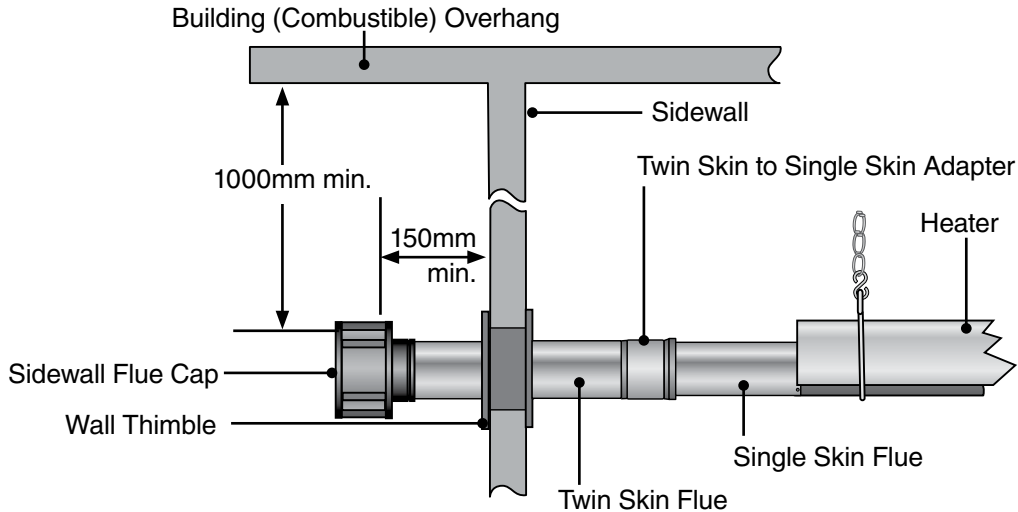

Optional Unflued Operation

⚠ WARNING



Not for residential use. The use of unflued tube heaters in residential indoor spaces may result in property damage, serious injury or death. Use unflued operation in commercial and industrial installations with proper ventilation rates only.

When installing in an un-vented configuration:

- A factory supplied flue cap/diffuser (P/N: WVE-GALV) must be used.
- Flueing of the space is required to dilute the by-products of combustion. Sufficient displacement of fresh air intake and exhaust by-product must be provided.
- The minimum clearance between the air intake and the exhaust terminal is 1220mm. **NOTE:** When installing in a U-bend configuration, use caution to separate flue gases from heater intake.
- A minimum positive air displacement (movement) for **I2H and I2L gas:** 2m³/hr per kW is required.
- A minimum positive air displacement (movement) for **I3P Gas:** 2.3m³/hr per kW is required.

NOTE: Gravity or mechanical means may be used to accomplish the air displacement. Local codes may require that the mechanical exhaust system be interlocked with the electrical supply line to the heaters, enabling both to function simultaneously.

- The use of outside combustion air intake is recommended.

Figure 3.24 • Minimum end clearance for unflued heater

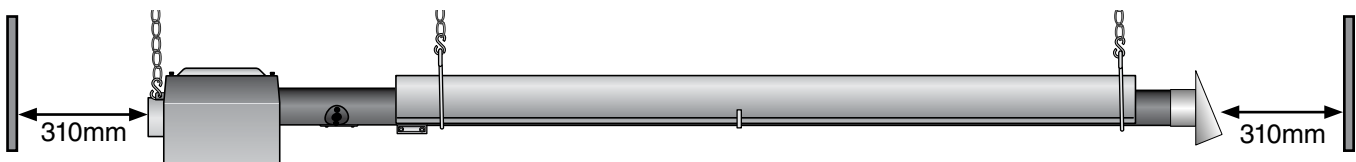

Combustion Air Requirements

NOTICE

This heater has a factory preset air orifice for proper combustion air supply. If combustion air is to be provided for a tightly closed area, 440 sq. mm of free air opening must be provided for each kW of heater input.

Non-contaminated air for combustion must be ducted to the heater if chlorinated or fluorinated contaminants, high humidity and other contaminants such as sawdust or welding smoke are present in the area where the heater is installed, or if the building has a negative pressure.

Combustion air intake may be located on either the sidewall or the roof. Figures 3.25 - 3.27.

Figure 3.25
Vertical Outside Air Supply
for Single Heater • Side View

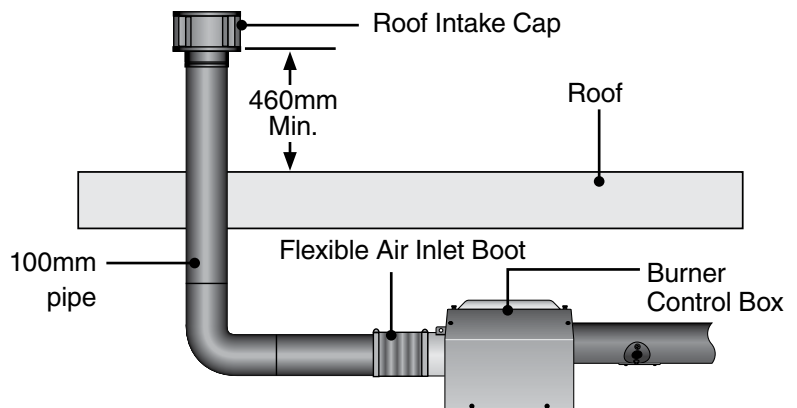

Figure 3.26
Horizontal Outside Air Supply
for Single Heater • Side View

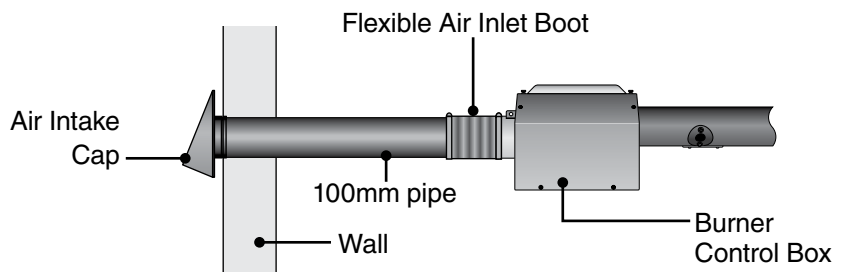
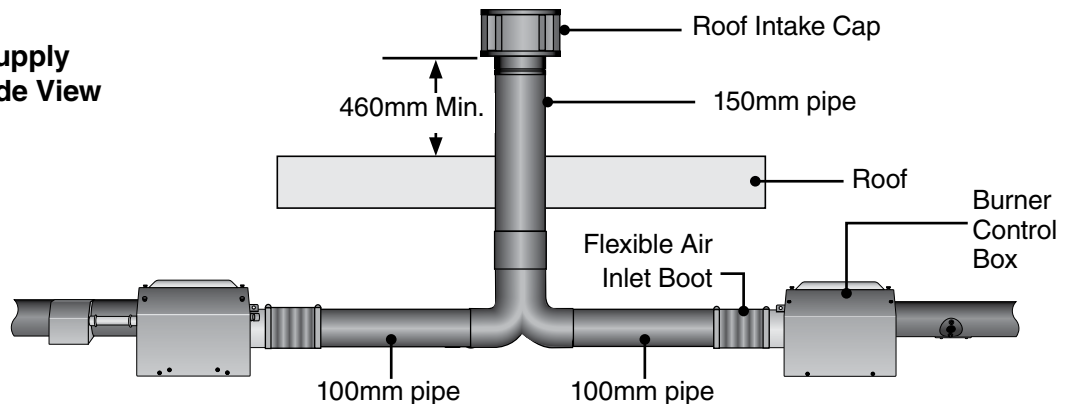

Figure 3.27
Vertical Outside Air Supply
for Double Heater • Side View

Note: Common intake heaters must share the same thermostat.



Combustion Air Requirements

Guidelines:

Limitations for length and size of combustion air intake duct

Single Heater Intake		Dual Heater Intake	
Air Intake Duct Size	Max. Intake Length	Duct Size	Max. Intake Length
100mm	6100mm	100mm.(single)/150mm.(dual)	6100mm
130mm	9140mm	100mm.(single)/200mm.(dual)	9145mm
150mm	12200mm	Consult factory for longer intake lengths.	

General Requirements:

- No more than two 90 degree elbows are allowed.
- Allow for expansion. Use a 100mm diameter flexible hose to connect the duct to the burner control box.
- In humid environments, use insulated duct, PVC pipe or DWV (drain waste vent) to prevent condensation on the outer surface.
- Do not draw combustion air from attic space or other negatively pressured areas.
- A factory approved wall intake cap (P/N: WIV-4) must be used with horizontal outside air intake ducts. The wall intake cap must be installed to prevent blockage. Locate the intake where dirt, steam, snow, etc. will not contaminate or clog the intake screen.
- Separate air intake duct from flue pipe a minimum of 100mm. Also, place pipe higher than adjacent air intake duct.

Figure 3.28 • Wall Intake Cap

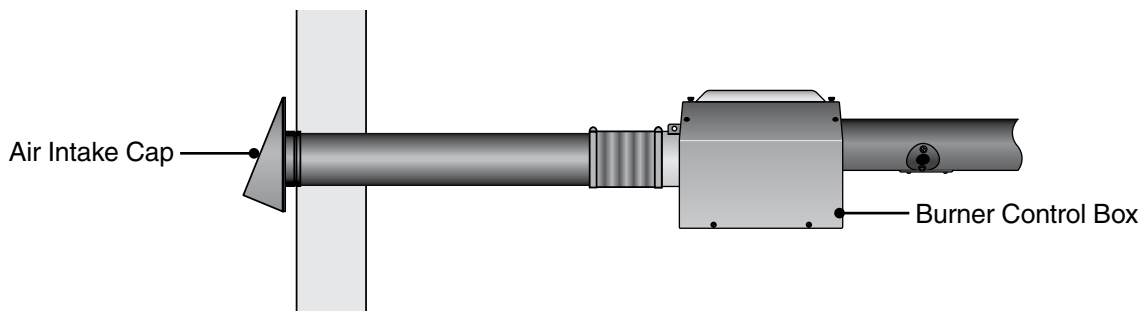

Gas Supply

⚠ WARNING



Improperly connected gas lines may result in fire, explosion, poisonous fumes, toxic gases, asphyxiation or death. Connect gas lines in accordance to national, state, provincial and local codes.

Important! Before connecting the gas supply to the burner control box:

- Verify that the heater's gas type (as listed on the rating plate) matches that of your application.
- Check that the gas piping and service has the capacity to handle the total gas consumption of all heaters being installed, as well as any other gas appliances being connected to the supply line.
- Check that the main gas supply line is of proper diameter to supply the required fuel pressures.
- If utilizing used pipe, verify that its condition is clean and comparable to a new pipe. Test all gas supply lines in accordance with local codes.
- Test and confirm that inlet pressures are correct. Refer to the rating plate on the burner control box for required minimum and maximum pressures. The gas supply pipe must be of sufficient size to provide the required capacity and inlet pressure to the heater (if necessary, consult the local gas company). Do not exceed the maximum allowed pressure for the heater, the space or the gas piping system.

Gas Supply and Pressure Chart

Type of Gas	Chart	Composition	Calorific Value	Required Burner Pressure	Minimum Supply Pressure*	Maximum Supply Pressure
I2H (G20-Natural)	5	CH ₄ = 100 [methane]	37.78MJ/m ³	9-10 Mbar <small>(reference chart on page 40 for your model)</small>	11.5-12.5 Mbar <small>(reference chart on page 40 for your model)</small>	50 Mbar
I2L (G25-Derated Natural)	6	CH ₄ = 86 N ₂ = 14 [methane]	32.49MJ/m ³	13-15 Mbar <small>(reference chart on page 40 for your model)</small>	15.5-17.5 Mbar <small>(reference chart on page 40 for your model)</small>	50 Mbar
I3P (G31-Liquified Petroleum)	7	C ₃ H ₈ = 100 [petroleum]	95.65MJ/m ³	25 Mbar	27.5 Mbar	50 Mbar

* For purpose of adjustment

NOTE: Check manifold pressure at the tap on the gas valve. Readings will be above atmospheric pressure.

Gas Supply

Adjusting Burner Pressure:

- ❶ Remove the lid to the valve compartment.
- ❷ Open the pressure nipple (Figure 3.29-A) and connect pressure meter tube.
- ❸ Remove the cap over the adjusting screws on the gas valve pressure regulator. Place a 10mm spanner (wrench) on the outer adjusting nut and a screwdriver on the black inner adjusting screw. The outer adjusting nut (Figure 3.29-C) regulates the high fire; whereas the black inner screw (Figure 3.29-B) regulates the low fire. **NOTE:** During adjustment of the nut (C), the screw (B) must be kept in position otherwise it will turn together with the nut (C).
- ❹ Adjust high fire first by turning the nut (C). Pressure is increased by turning clockwise.
- ❺ Replace the burner control box lid, then operate the heater to check high fire burner pressure.
- ❻ Repeat this procedure from point 4 until proper burner pressure is achieved. Also, repeat this procedure to adjust low fire burner pressure by turning screw (B).
- ❼ After low fire adjustment, confirm that the high fire pressure value did not change.
- ❽ Replace all caps and plugs, close the pressure nipple carefully and secure the burner control box lid.

Figure 3.29 • Burner Pressure Adjustment

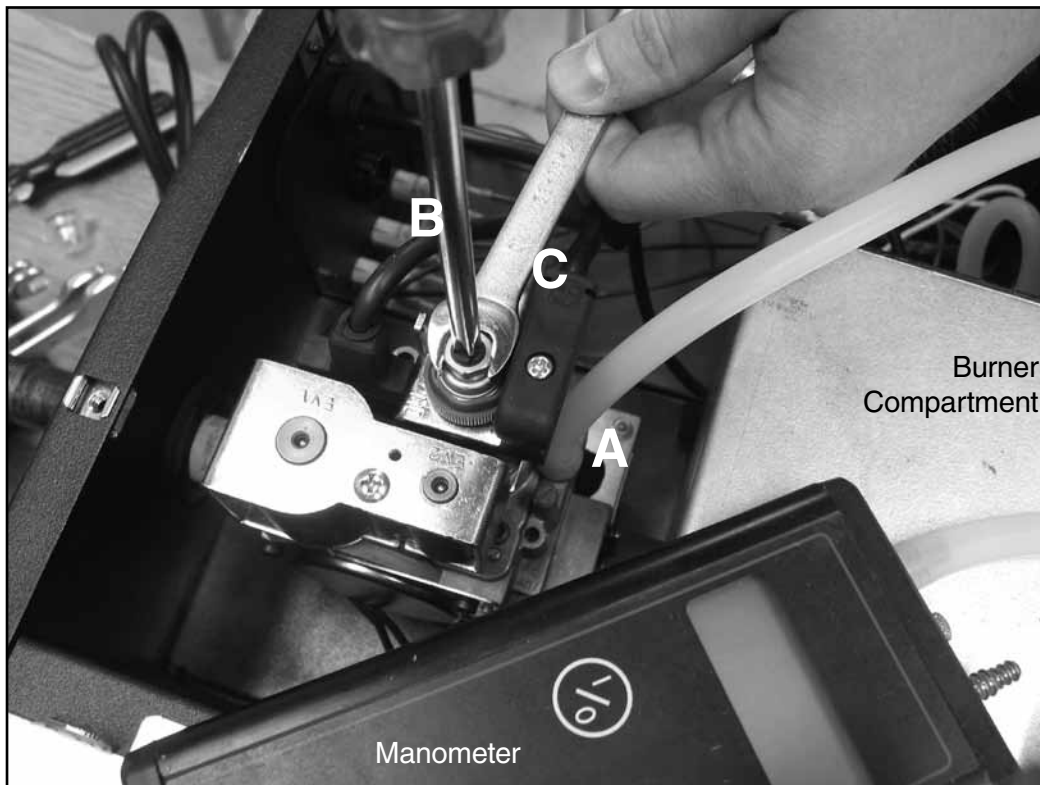

Gas Connection

WARNING



Failure to install, operate or service this appliance in the approved manner may result in property damage, injury or death. Only trained, qualified gas installation and service personnel may install or service this equipment.

To connect the gas:

This heater must be installed and service by trained gas installation and service personnel only.

The installation must conform with local building codes and regulations.

IMPORTANT! The heating system will expand and contract during operation. Allowances for expansion must be made between the connection to the heater and the gas supply. Excessive bending, kinks, twists or vibration must be avoided. A flexible gas connection of approved type is required. Flexible stainless steel gas connectors installed in one plane, and without sharp bends, kinks or twists is recommended.

The gas pipe and connection **must** be supported independently. Do not install gas supply line in a manner that bears the weight of the heater. Connect the main gas supply line with an approved flexible connector (Figure 3.30-3.31) or, if national or local codes require rigid piping, a swing joint. See the safety messages at the beginning of this section.

The gas outlet must be in the same room as the appliance and accessible. It may not be concealed within or run through any wall, floor or partition. When installing the heater in a corrosive environment (or near corrosive substances), use a gas connector suitable for the environment. Do not use the gas piping system to electrically ground the heater.

- ❶ Install a sediment trap / drip leg for condensation which may occur at any point of the gas supply line. This will decrease the possibility of loose scale or dirt in the supply line entering the heater's control system and causing a malfunction. **NOTE:** High pressure gas above 50 Mbar requires a high pressure regulator and ball valve.
- ❷ Form the stainless steel flexible connector into a smooth C-shape allowing 305mm between the flexible connector's end nuts (see Figure 3.30).
- ❸ Attach the ball valve to the gas supply pipe. Apply pipe compound to adapter threads to seal the joint. Use only a pipe compound resistant to LP (I3P-G31).

NOTE: Provide a 3.2mm BSP plugged tapping accessible for test gauge connection immediately upstream of gas connection to the heater (provided on ball valve). An isolation valve shall be fitted immediately adjacent to the appliance which, when closed, allows the complete burner assembly to be disconnected for maintenance or repair.

Gas Supply

⚠ CAUTION

When using a stainless steel flexible connector, **do not** attach the connector nuts directly to the gas pipe supply. Connector nuts must be installed to an approved adapter.

- ④ Attach the flexible connector to the adapter and burner control box inlet. Seal the joints.
NOTE: Excessive torque on the manifold may misalign the orifice. **Always** use two wrenches to tighten mating pipe connections.
- ⑤ Final assembly must be tested for gas leaks according to current I.E.E. Regulations and other relevant codes of practice.

IMPORTANT: Before installation, check that local distribution conditions, nature of gas and pressure, and the adjustment of the appliance are compatible.

⚠ WARNING



Testing for gas leaks with an open flame or other sources of ignition may lead to a fire or explosion and cause serious injury or death. Test in accordance with I.E.E and other relevant codes of practice.

Figure 3.30 • Gas Connection (Flexible Gas Connection shown) • Side View

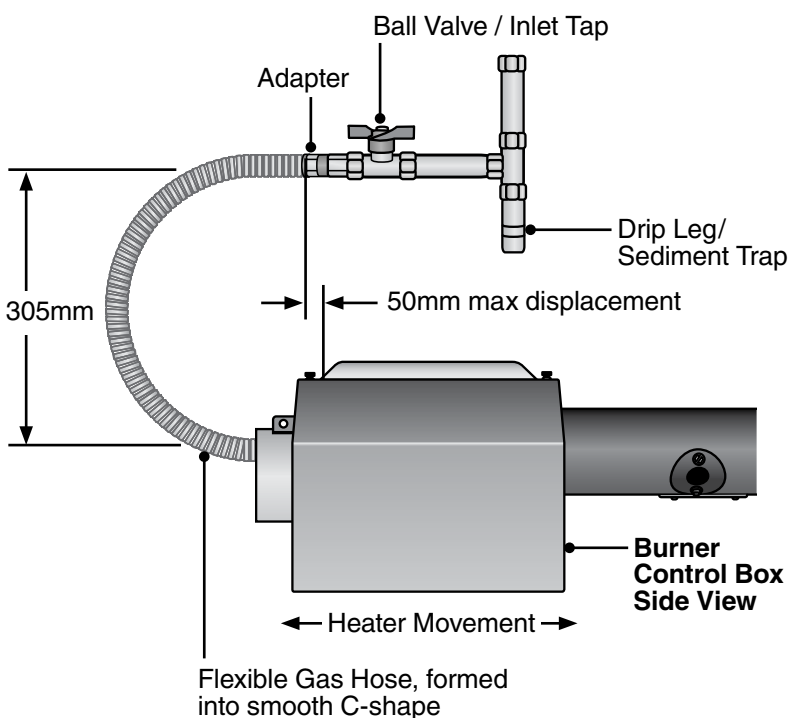
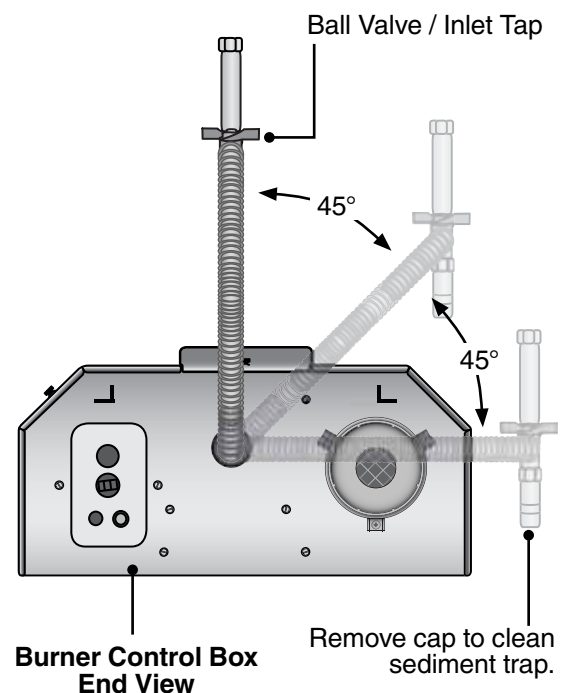

Figure 3.31 • Gas Connection (Flexible Gas Connection shown) • End View



3.12 Electrical Requirements

- Verify that the heater's voltage (as listed on the rating plate) matches that of your application.
- Heaters operate on 230 volts, 50Hz., single phase. The amperage requirement is 0.6 Amps running current per heater.
- The heater must be grounded in accordance with the I.E.E. Regulations and local codes.
- Observe proper electrical polarity.
- The method of connection to the electrical supply must facilitate complete isolation and should preferably be made via a fuse isolator having a contact separation of at least 3mm in all poles and supplying the appliance only.
- Clearance to combustibles must be maintained between electrical apparatus and wiring (see page 7).
- Wiring must not be run above or below the heater or exposed to the radiant output.
- Installations utilizing a 24-volt thermostat require a relay transformer.

Figure 3.32 - Field Wiring Diagram

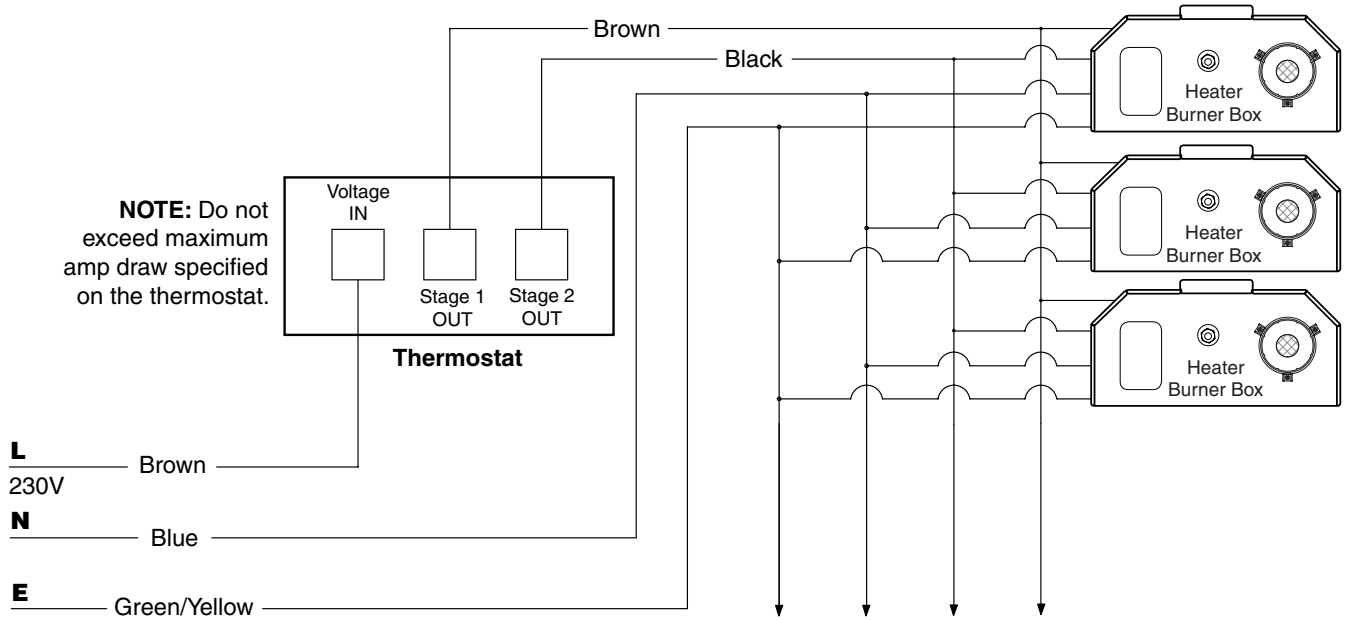

Internal Wiring Diagrams

If any of the original wire as supplied with this appliance must be replaced, it must be replaced with wiring material having a temperature rating of at least 105°C.

Figure 3.33 - Internal Wiring Diagram

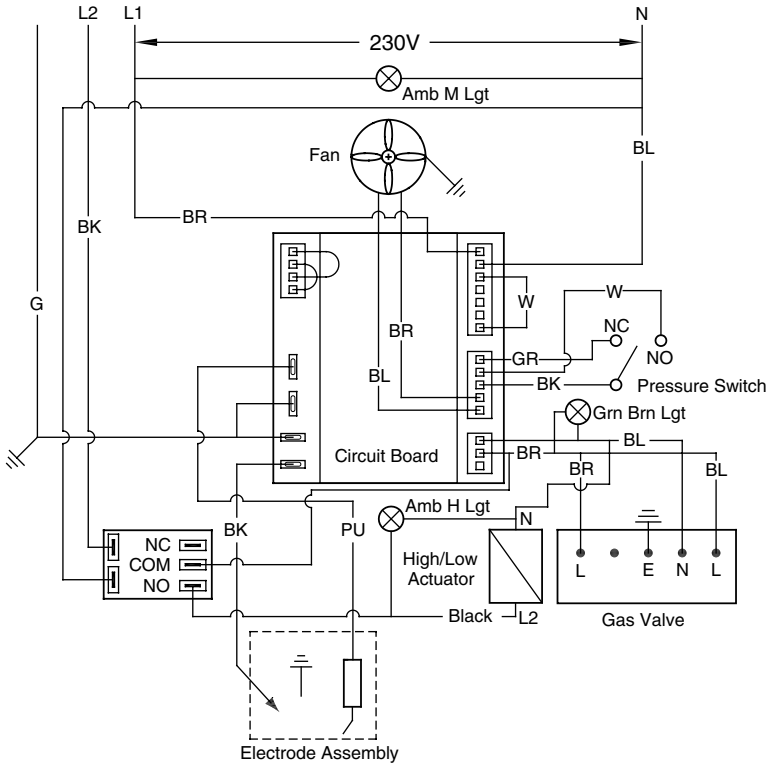
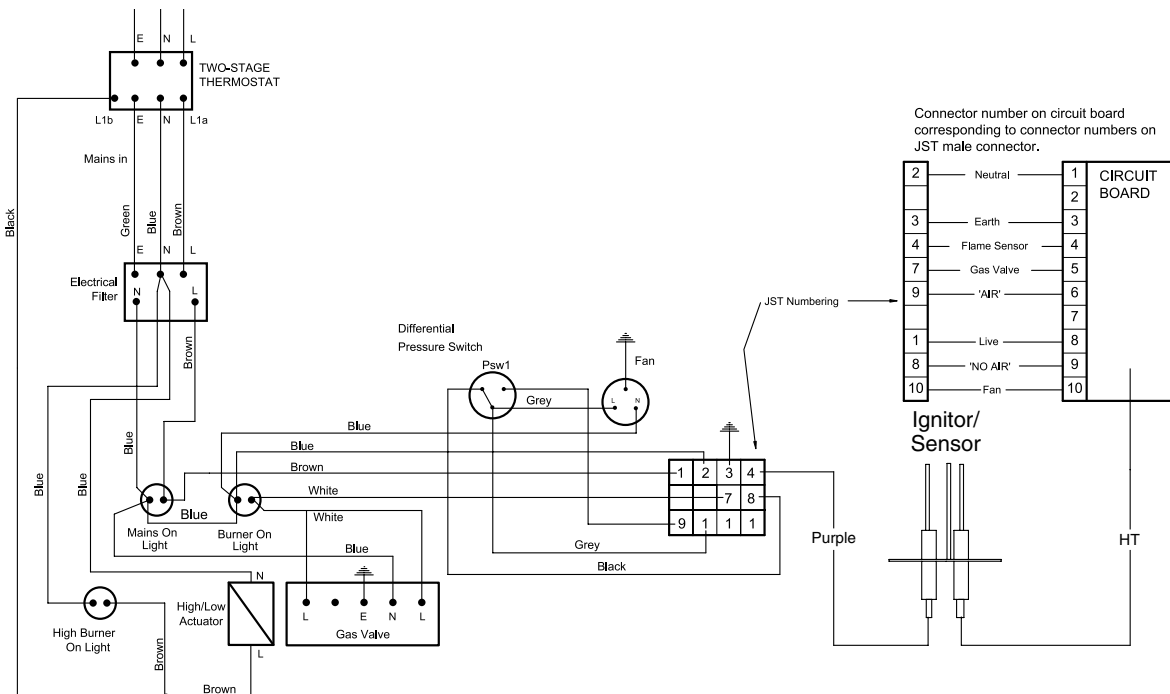

Figure 3.34 - Internal Wiring Diagram



4.0 Operation

⚠ WARNING



This heater is not equipped with a pilot ignition system.
Do not attempt to light the system manually.

Commissioning Procedures:

- 1 Ensure that ball valve to the heater is turned “OFF”.
- 2 Purge air from the gas supply line and test for gas soundness in accordance with relevant Standards.
- 3 Check that all electrical connections are made to the heater and that the unit has a sound earth connection.
- 4 Remove operating pressure test point screw and connect the pressure gauge.
- 5 Switch on power to the heater. After a purge period, the gas valve is energized and will attempt to ignite for 5-10 seconds. (If ignition fails, the heater will lock out). To reset the heater, briefly interrupt power to the heater.
- 6 With the heater running, test operating pressure. Refer to the Technical Specifications chart on page 3 for details on your particular gas type.

Lighting Procedures:

- 1 Verify that service lid is secured.
- 2 Open (turn on) gas supply to the heater.
- 3 Close (turn on) electrical circuit (typically thermostat).
- 4 If the heater fails to light, turn off gas, open electrical circuit (set thermostat to lowest setting or to off). Wait five (5) minutes before repeating above steps.

Shutdown Procedures:

- 1 Open (turn off) electrical circuit.
- 2 Close (turn off) gas supply to the heater.
- 3 Wait five (5) minutes before relighting heater.

Sequence of Operation

Starting Circuit

Upon a call for heat, the circuit board verifies that the pressure switch is in the proper position (open). The circuit board energizes the blower. Once operational static pressure is achieved, the differential switch will close initiating the ignition sequence. The system is purged for 10 seconds and the circuit board sends a spark through the electrode. The gas valve is opened and an attempt at ignition is made for 10 seconds. If ignition fails, the heater will go into lockout until the electrical supply is interrupted for more than two seconds.

Running Circuit

After ignition, the flame rod monitors the flame. As long as flame is present, the valve is held open. If the flame is lost, the circuit board acts to close the valve within one second and a new trial sequence identical to that at startup is initiated. If proof of flame is not established within 10 seconds, the unit will lock out. If lockout occurs, the control can be reset by briefly interrupting the power source.

5.0 Maintenance

⚠ WARNING



Personal injury or death may result if maintenance is not performed by properly trained gas installer or service personnel. Contact the installing distributor or place of purchase for service. **Do not operate heating system if repairs are necessary.**



Allow heater to cool prior to servicing.
Disconnect power to heater before servicing.
Use protective glasses when maintaining the heater.

Routine Inspection:

At least once per year, the heating system should be inspected and serviced by trained gas installation and service personnel only. This inspection should be performed at the beginning of the heating season to insure that all heater components are in proper working order and that the heating system operates at peak performance. Particular attention should be paid to the following items.

- **Blower Motor:** Annual oiling of the blower motor with SAE 20 oil will extend bearing life significantly. Ensure that the squirrel cage in the blower is kept clean. If dirt becomes a problem, installation of outside air intake ducts for combustion is recommended.
- **Vent pipe system:** Check the outside termination and the connections at the heater. Inspect the vent exhausts for leakage, damage, fatigue, corrosion and obstructions. If dirt becomes a problem, installation of outside air intake ducts for combustion is recommended.
- **Combustion air intake system** (when applicable): Check for blockage and/or leakage. Check the outside termination and the connection at the heater.
- **Heat exchangers:** Check the integrity of the heat exchangers. Replace if there are signs of structural failure. Check for corrosion and/or buildup within the tube exchanger passageways.
- **Burner:** Check for proper ignition, burner flame and flame sense. Flame should extend directly outward from burner without floating or lifting.
- **Wiring:** Check electrical connections for tightness and/or corrosion. Check wires for damage.
- **Gas Connection:** Inspect the integrity of the gas connection to the heater. Check for leaks, damage, fatigue or corrosion. Do not operate if repairs are necessary and turn off gas supply to the heater. Contact service personnel.
- **Reflectors:** Inspect the integrity of the reflectors for damage, separation, missing or misaligned sections. Do not operate if repairs are necessary. Repair or replace as required per the general installation manual.

To maintain effective infrared heating, always keep both sides of the reflector clean. Dirt and dust can be vacuumed up or wiped with a soap and water solution. Use metal polish if the reflectors are severely dirty.

Contact service personnel if repairs are necessary. Do not operate unit.

Troubleshooting Guide

NOTE: Contact appliance manufacturer prior to replacing parts other than those specified in this manual.

Chart 5.1 Troubleshooting Guide

Symptom	Possible Cause	Corrective Action
Thermostat closed, fan doesn't operate.	<ul style="list-style-type: none"> Blown fuse. Faulty thermostat. Loose or disconnected wire. Faulty fan, circuit board or pressure switch. 	<ul style="list-style-type: none"> Replace. Replace. Repair as required. Lubricate, repair or replace.
Thermostat closed. Fan operates. Electrode does not spark.	<ul style="list-style-type: none"> Loose or disconnected wire. Box lid or gasket not in place. Plugged pressure switch lines. Faulty electrode set. Faulty pressure switch. Faulty circuit control. 	<ul style="list-style-type: none"> Repair as required. Put in place. Clean as necessary. Replace. Replace only. Do not adjust. Replace circuit control.
Thermostat closed. Fan and electrode operate. After 10 seconds electrode stops sparking. No ignition.	<ul style="list-style-type: none"> Closed gas supply. Dirty or restricted orifice. Faulty valve or disconnected valve wire. 	<ul style="list-style-type: none"> Open all gas connections. Remove and clean with soft object. Repair or replace.
Thermostat closed. Fan and electrode operate. Ignition occurs. Burner cycles off and will not recycle.	<ul style="list-style-type: none"> No electrical ground. Faulty circuit control. Low gas pressure. Poor circuit control connection. 	<ul style="list-style-type: none"> Connect electrical ground to junction box. Replace. Provide required gas pressure. Repair or replace.
Thermostat closed. Fan and electrode operate. Ignition occurs. Burner cycles off. Burner cycles on.	<ul style="list-style-type: none"> Low gas pressure. Baffle improperly positioned. Faulty pressure switch. Restricted flue. 	<ul style="list-style-type: none"> Provide required gas pressure. Reposition baffle. Replace. Remove foreign matter.
Loss of heater efficiency.	<ul style="list-style-type: none"> Low gas pressure. Dirty or restricted orifice. Foreign matter inside burner. Unit cycles on and off. Reflector is dirty or not in place. Clogged fan blower. 	<ul style="list-style-type: none"> Provide required gas pressure. Remove. Clean with a soft object. Clean as necessary. Check previous symptom. Clean with aluminum cleaner and soft cloth. Clean.
Radiant tube leaking burnt gases.	<ul style="list-style-type: none"> Loose tube connections. Holes or cracks in radiant tubes. 	<ul style="list-style-type: none"> Ensure that tubes are fully connected and clamped properly. Replace.
Condensation.	<ul style="list-style-type: none"> Stack length is too long. Light gauge flue stack used. Contaminated combustion air. 	<ul style="list-style-type: none"> Shorten stack length. Minimum of 26 ga. flue pipe required. Provide fresh air inlet duct.
Tube bowing.	<ul style="list-style-type: none"> Insufficient combustion air. Over fired. Contaminated combustion air. Heater unable to expand properly. Baffle installed incorrectly. 	<ul style="list-style-type: none"> Provide 440 sq. mm. of free air per kW of input. Check gas pressure and orifice size. Provide fresh air inlet duct. Remount with flexible inlet or flue pipe. Move to furthest tube section from burner.
Tube corroding.	<ul style="list-style-type: none"> Contaminated combustion air. 	<ul style="list-style-type: none"> Provide fresh air inlet duct.
Visual inspection of burner operation not possible.	<ul style="list-style-type: none"> Dirty or sooted sight glass. Unit mounted upside-down. 	<ul style="list-style-type: none"> Remove, clean or replace. Mount correctly.
Stack sooting.	<ul style="list-style-type: none"> Insufficient combustion air. Improper gas. Dirty fan or blockage. 	<ul style="list-style-type: none"> Provide 440 sq. mm. of free air per kW of input. Correct with proper gas input (or clean). Clean and/or remove blockage.
Odor or fumes in space (normal during first firing and will subside after initial burn off, approximately 20 minutes).	<ul style="list-style-type: none"> Vaporized solvents decomposing when contacting radiant tubes. Evaporation of oils, solvents at floor level. Fork lifts. Loose tube / flue connections. 	<ul style="list-style-type: none"> Provide proper ventilation. Provide proper ventilation. Tighten tube clamps to 30-44 Nm. Seal flue pipes.

6.0 Parts

Figure 6.1 • Burner Assembly Components

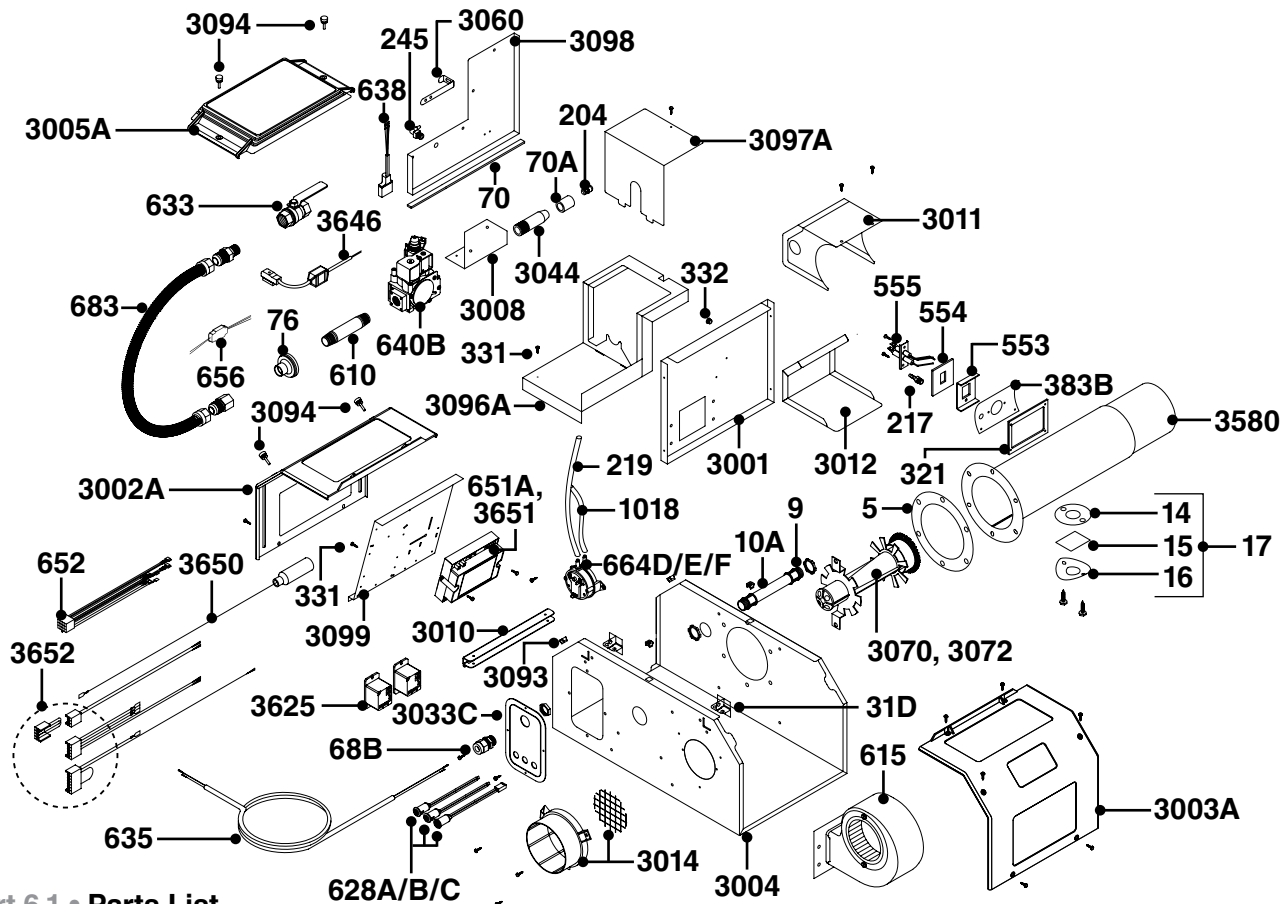

Chart 6.1 • Parts List

Part #	Description	Part #	Description
TP-5	Flange Gasket	TP-70A	25.4 mm Control Box Gasket (0.15 m)
TP-9	Conduit Coupling	TP-76	Rubber Grommet
TP-10A	Conduit	TP-82	Reflector Center Support
TP-14	Sight Glass Gasket	TP-105	Reflector End Cap
TP-15	Sight Glass	TP-106	Reflector End Cap Clips (8)
TP-16	Sight Glass Washer	TP-113	Reflector Tension Spring
TP-17	Sight Glass Kit	TP-204	Gas Orifice - Consult Factory
TP-19B	101mm Wire Hanger with Tension Spring	TP-217	Brass Pressure Switch Barb Fitting
TP-20C	3050mm Aluminum Reflector	TP-219	Differential Vinyl Sensing Tube (Burner)
TP-20D	3050mm Stainless Steel Reflector*	TP-220	101mm Stainless Steel Tube Clamp
TP-21B	101mm Tube Clamp	TP-245	Plastic Gas Valve 90° Vent
TP-26A	3050mm Alum. Combustion/Radiant Tube	TP-321	Ignition Plate Gasket
TP-26B	3050mm Titanium Combustion Tube	TP-331	Green Self-Tap Ground Screw (Qty. 2)
TP-26C	3050mm Uncoated Hot Rolled Radiant Tube	TP-332	Divider Grommet
TP-26D	3050mm Stainless Steel Radiant Tube*	TP-383B	Spark Igniter Plate
TP-26E	3050mm Stainless Steel Combustion Tube*	TP-553	Igniter Mounting Bracket
TP-31D	Control Box Mounting Bracket (Qty. 2)	TP-554	Igniter Mounting Bracket Gasket
TP-65I	Interlocking 838mm Baffle Section	TP-555	Spark Igniter Electrode
TP-68B	Large Strain Relief Bushing	TP-579	101mm Wire Hanger w/o Tension Spring
TP-70	12.7 mm Control Box Gasket (0.26 m)	TP-610	BSP Gas Valve Pipe Nipple

* Optional upgrade or add-on item.

Basic Parts List

Figure 6.2 • Tube & Reflector Components

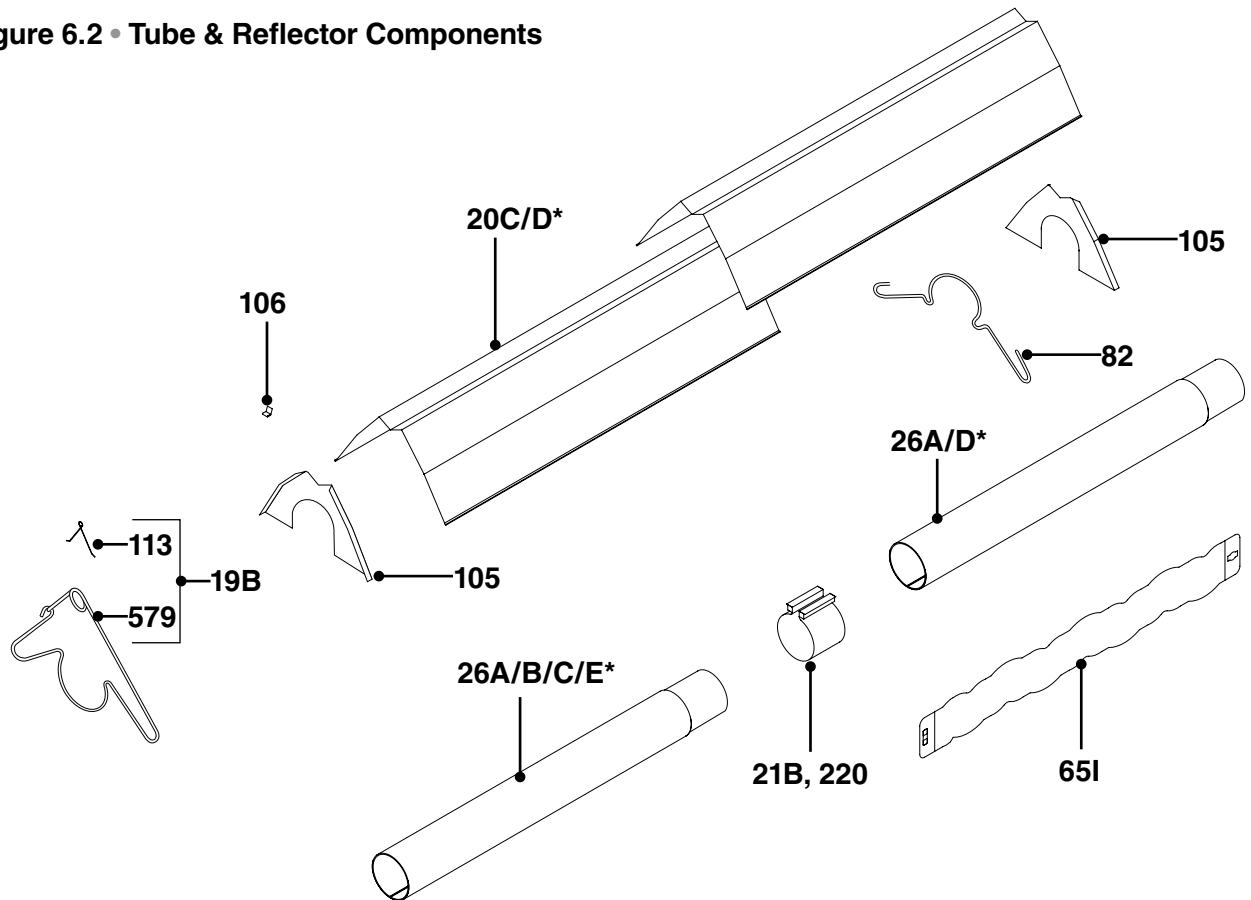





Part #	Description	Part #	Description
TP-615	220-240V 50/60Hz Fan	TP-3010	Service Panel Hinge
TP-628A	Red Indicator Light	TP-3011	Electrode Set Igniter Box
TP-628B	Green Indicator Light	TP-3012	Electrode Set Box Cover
TP-628C	Amber Indicator Light	TP-3014	Plastic Air Orifice Collar - Consult Factory
TP-633	Ball Valve Shut-off	TP-3033C	GTD Power Entry Plate
TP-635	4-Core Cable Wire	TP-3044	Gas Manifold
TP-638	Valve Main Coil Cord	TP-3060	Pressure Switch Mounting Bracket
TP-640B	230V Gas Valve Assembly	TP-3070	Low kW Burner (15-30 kW)
TP-651A	Circuit Control Board 0342G15B	TP-3072	High kW Burner (35-60 kW)
TP-652	JST Wiring Harness	TP-3093	#8-32 Cage Nut (Qty. 4)
TP-656	Ignition Filter	TP-3094	#8-32 x 1/2" Black Nylon Shoulder Screw (Qty. 4)
TP-664D	N.O. Atmospheric Pressure Switch - .10 (25Pa)	TP-3096A	Valve Compartment Bottom Panel
TP-664E	N.O. Atmospheric Pressure Switch - .14 (35Pa)	TP-3097A	Valve Compartment Top Panel
TP-664F	N.O. Atmospheric Pressure Switch - .20 (50Pa)	TP-3098	Valve Compartment Side Panel
TP-683	Stainless Steel Flexible Gas Connector	TP-3099	Controls Mounting Panel
TP-1018	Differential Switch Vinyl Sensing Tube (Exhaust)	TP-3580	Spark Burner Tube with Flange
TP-3001	Divider Panel	TP-3625	Picker Relay (Qty. 2)
TP-3002A	Left End Moulded Plastic Panel	TP-3646	AC Rectifier Voltage Cord
TP-3003A	Right End Moulded Plastic Panel	TP-3650	High Voltage Spark Wire
TP-3004	Main Control Box Panel	TP-3651	230 VAC Pactorl Circuit Board
TP-3005A	Control Box Chamber Moulded Plastic Lid	TP-3652	Wiring Harness
TP-3008	Gas Valve Mounting Bracket		

* Optional upgrade or add-on item.

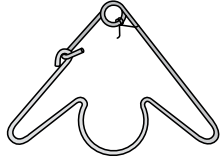
7.0 GTD Series Kit Contents

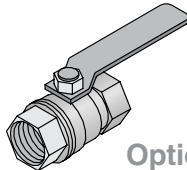
Prior to installation, verify that you have received all heater components included with your tube heater. Refer to the chart below for a list of the kit contents for your model heater. Materials not included in the kit (e.g. sheet metal screws, vent material, terminals, etc.) are the responsibility of the installer.

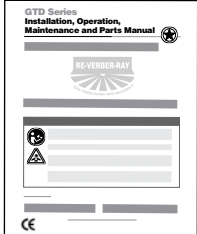
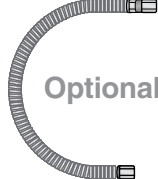
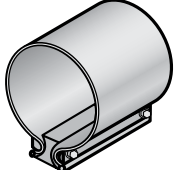
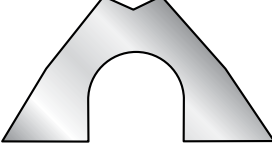
Kit Contents for GTD Series - Reference the column for your model.								
TP-19B Hanger with Reflector Tension Spring 	TP-82 Reflector Center Support (RCS) 	TP-633* Shut-Off Valve  Optional	TP-106 Reflector End Caps Clips 	Installation, Operation and Maintenance Manual F/N: LIOGTD 				
TP-683* Stainless Steel Flexible Gas Connector  Optional	TP-21B Tube Clamps 	TP-105 Reflector End Caps 						
Part No.	Description	Unit Length	6M	9M	12M	15M	18M	21M
TP-19B	Hangers w/ Tension Spring		3	4	5	6	7	8
TP-21B	Tube Clamps		2	3	4	5*	6*	7*
TP-82	Reflector Center Support		2	3	4	5	6	7
TP-105	Reflector End Caps		2	2	2	2	2	2
TP-106	Reflector End Cap Clips		8	8	8	8	8	8
TP-633	Shut-Off Valve*		—	—	—	—	—	—
TP-683	S.S. Flexible Gas Connector*		—	—	—	—	—	—
LIOGTD	GTD IOM		1	1	1	1	1	1
Filled By:								

*Optional Accessory