

MAINTENANCE  
USERS

Instruction and **IE** recommendation booklet



RAPAX 100 V2





## **Dear Customer,**

*Our compliments for having chosen a top-quality Immergas product, able to ensure well-being and safety for a long period of time. As an Immergas Customer, you can also count on a qualified after-sales service, prepared and updated to guarantee constant efficiency of your boiler. Read the following pages carefully: you will be able to draw useful tips on the correct use of the device, compliance of which will confirm your satisfaction with the Immergas product.*

*For assistance and routine maintenance, contact Authorised Service Centres: they have original spare parts and are specifically trained directly by the manufacturer.*

## **General recommendations**

*All Immergas products are protected with suitable transport packaging.*

*The material must be stored in a dry place protected from the weather.*

*The instruction booklet is an integral and essential part of the product and must be given to the new user in the case of transfer or succession of ownership.*

*It must be stored with care and consulted carefully, as all of the warnings provide important safety indications for installation, use and maintenance stages.*

*This instruction booklet provides technical information for installing Immergas boilers. As for the other issues related to boiler installation (e.g. safety in the workplace, environmental protection, accident prevention), it is necessary to comply with the provisions specified in the regulations in force and with the principles of good practice.*

*In compliance with the legislation in force, the systems must be designed by qualified professionals, within the dimensional limits established by the Law. Installation and maintenance must be performed in compliance with the regulations in force, according to the manufacturer's instructions and by an authorised company, which has the specific technical skills in the system sector, as provided for by Law.*

*Improper installation or assembly of the Immergas device and/or components, accessories, kits and devices can cause unexpected problems for people, animals and objects. Read the instructions provided with the product carefully to ensure proper installation.*

*Maintenance must be carried out by an authorised company. The Authorised Service Centre represents a guarantee of qualification and professionalism.*

*The device must only be destined for the use for which it has been expressly declared. Any other use will be considered improper and therefore potentially dangerous.*

*If errors occur during installation, operation and maintenance, due to non-compliance with technical laws in force, standards or instructions contained in this booklet (or however supplied by the manufacturer), the manufacturer is excluded from any contractual and extra-contractual liability for any damages and the device warranty is invalidated.*

## INDEX

1	Important recommendations.....	5	4	Parameter settings / Use.....	15	5	Recommendations - maintenance and repairs.....	17
1.1	Warnings.....	5	4.1	remote panel.....	15	5.1	Advice for the user.....	17
1.2	installation.....	5	4.2	Description of the symbols.....	15	5.2	Household maintenance.....	17
1.3	Hydraulic connection.....	5	4.3	Main menu.....	15	5.3	Maintenance by approved professionals.....	17
1.4	Wiring.....	5	4.4	System settings.....	16	5.4	Troubleshooting support.....	18
2	Introducing the product.....	6	4.5	Parameters to be adjusted upon installation.....	16	5.5	Work on the water heater.....	19
2.1	Important advice.....	6	4.6	Selecting the operating mode.....	16	5.6	Quick fault diagnosis for use carried out by a professional technician.....	20
2.2	Technical specifications.....	6	4.7	Display the information.....	16	5.7	After-sales service.....	20
2.3	Dimensions and components.....	7				5.8	Scope of application of the warranty.....	20
3	Installation.....	9				5.9	Declaration of conformity.....	20
3.1	Choosing the place of installation.....	9				6	Product fiche (in compliance with Regulation 812/2013).....	21
3.2	Product installation.....	11				7	Parameters for filling in the package fiche.....	22
3.3	Hydraulic connection.....	12						
3.4	Air intake connection.....	12						
3.5	Electrical connection.....	12						
3.6	Water heater wiring diagram.....	14						
3.7	Commissioning.....	14						

# 1 IMPORTANT RECOMMENDATIONS.

## 1.1 WARNINGS.

This device may only be used by adult users whose physical, sensory or mental abilities are not impaired.

Before using this device, this instruction booklet (User section) and/or the operating instructions should be ready by skilled technical staff.

Use by incompetent adult staff and especially by children is forbidden for safety reasons and due to issues of correct device operation and warranty. This device has been designed to serve one residential housing unit only (and similar) subject to assessment of the energy requirement for domestic hot water; it is not a heating system pursuant to the legislation in force.

## 1.2 INSTALLATION.

**Warning:** due to its weight (57 kg), this device must be handled with care to avoid injury to persons or damage to property and to the product itself. Installation must therefore be performed taking into account the following instructions:

- Install the device in a frost-free room. The warranty does not cover any device breakdown caused by excessive pressure due to the safety valve blocking because of ice.
- Ensure the wall on which the device is to be installed is suitable to withstand the device's own weight and that of the water content (100 litres approximately). It is recommended to perform a structural assessment by the designer of the dwelling.
- If the storage tank is mounted on a false ceiling, under the roof or above a living area, it is mandatory to install a drip tray to be connected to the drain.
- Suitably aerate the installation room in the event the device is to be installed in a room and/or in a position where the ambient temperature is always higher than 35°C.
- This device is intended for use up to a maximum height of 2000 m.
- Position the device in an accessible area and at such a distance from the wall to permit correct maintenance / accessibility (Paragraph 3.1).
- Refer to the installation diagrams (Paragraph 3.1).

**Caution:** failure to comply with recommended installation procedures, especially a room volume below the 20 m<sup>3</sup> minimum, may significantly reduce system performance.

- It is recommended to provide suitable shut-off valves on the hydraulic connection to allow for any routine and extraordinary maintenance operations which might require emptying/filling the water heater.
- In order to prevent any stability and safety issues, it is obligatory to secure the water heater on the wall using the fastening anchors supplied.

## 1.3 HYDRAULIC CONNECTION.

It is mandatory to install a safety device, set to be triggered at 0.7 MPa (7 bars) (not supplied with the water heater), sized 3/4", compliant with standard EN1487 as amended and added, and in any case compliant with local regulations in force, to be fitted to the cold water inlet of the water heater.

The safety device must be protected from ice.

The safety unit must be fitted with a discharge device (overpressure) to be operated regularly to remove any limestone deposits.

It must also be checked regularly to ensure it is not blocked.

The pressure reducer (not supplied as standard) is required when the water mains pressure exceeds 0.5 MPa (5 bars) and must be mounted on the main water supply line.

The safety unit must also be connected to an open drain pipe, in a frost-free environment, with a permanent downward gradient, to remove any expansion water from the heating process, or drainage water from the water heater. To perform any discharge operations of the water heater, strictly adhere to the following sequence:

- Disconnect the device from the electrical supply voltage.
- Disconnect the device from the mains water supply (cold water).
- Open the hot water tap.
- Actuate the discharge device of the safety unit.

## 1.4 WIRING.

Before removing the cover of the water heater, always ensure the power is dis-

connected, to prevent any risk of injury due to electric shocks.

The following must be provided upstream of the electrical system:

- A circuit breaker or 16A multi-pole fuse with contacts compliant with regulations in force.
- A 30 mA differential circuit breaker.

Should the power cable be found to be damaged for any reason, it must be replaced by the After-sales Support, and/or in any case by skilled and qualified staff.

The water heater must be connected to earth according to the methods set out by the regulations in force.

A special terminal, suitably marked  is provided for the specific purpose.

This manual is supplied jointly with the water heater; in the event of loss it may also be obtained from the Authorised area Support service or be downloaded from the suitable website.

## 2 INTRODUCING THE PRODUCT.

### 2.1 IMPORTANT ADVICE.

**Transport, handling and storage.** The product may be transported upright on a pallet, or rotated by 90° on its side

The appropriate side is shown clearly on an information label on the product packing box. It is forbidden to transport the product lying on its other sides as it could irreparably damage it.

**Note:** follow the transport and maintenance recommendations on the water heater's packaging.

**The product warranty is rendered null and void if the above instructions are not complied with. The manufacturer declines any liability for any faults to the product resulting from transport or handling not complying with the above recommendations.**

Under no circumstances may this product be stacked (Fig. 2-1).

**Safety directives.** The installation work and commissioning of thermodynamic water heaters can be hazardous due to high pressure and live electrical parts.

Thermodynamic water heaters must be installed, commissioned and serviced by trained and qualified staff only.

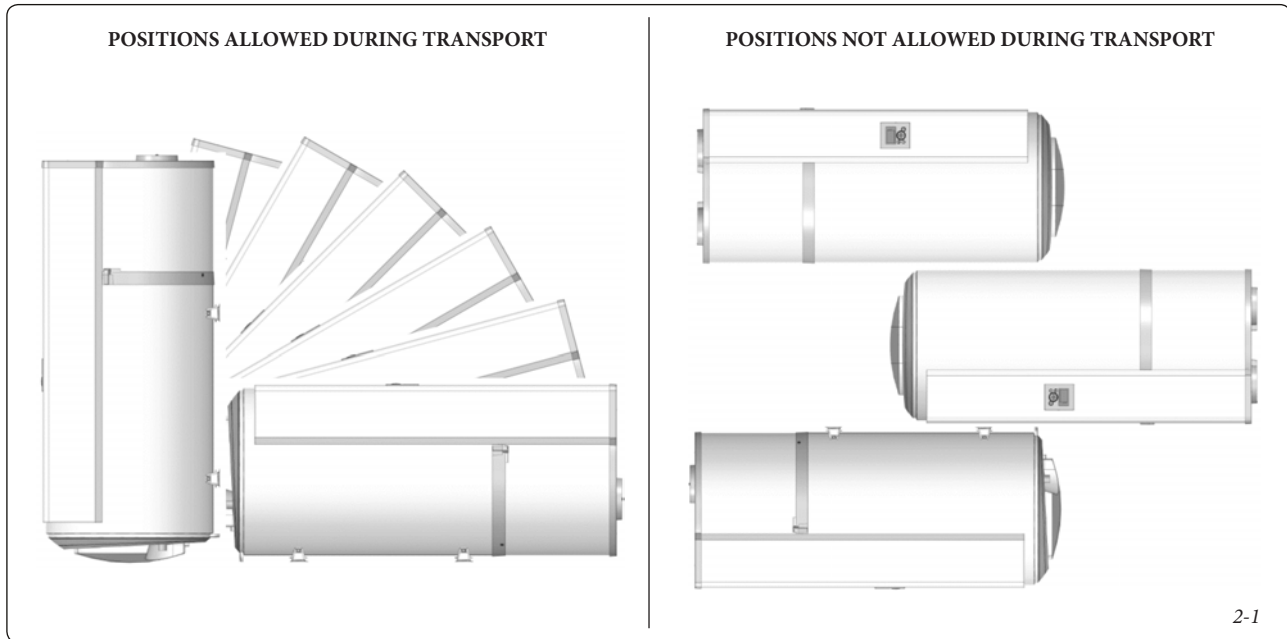

### 2.2 TECHNICAL SPECIFICATIONS.

Dimensions	mm	H 1234 x L 522 x D 538
Empty weight	kg	57
Tank capacity	l	100
Hot + cold water fitting		3/4" M
Anti-corrosion protection		Magnesium anode
Maximum operating pressure	bar	8
Electrical connection (voltage/frequency)		230 V single-phase 50 Hz
Max total power absorbed by the device	W	1550
Max power absorbed by heat pump	W	350
Power absorbed by auxiliary electrical unit	W	1200
Setting range of the water temperature of the heat pump	°C	from 50 to 62 (temperature factory setting 52°C)
Temperature range for using the heat pump (air temperature)	°C	from -5 to +43
Diameter of intake and exhaust ducts	mm	125
Air flow rate without ducts	m <sup>3</sup> /h	160
Load losses acceptable on ventilation circuit, without affecting performance	Pa	25
R134a refrigerant charge	kg	0.6
Coolant		R134a
Coolant mass	kg/l	0.006
Coolant volume	Ton CO <sub>2</sub> Eq.	0.86
Amount of hot water at 40°: V40td in 8h (HC) / 14h (HC+6h)	l	151 / 289
Coefficient of performance (COP)	-	2.47 - M
Power absorbed at steady speed (Pes)	W	20
Heating time(th)	h.min	7 h 27
Reference temperature(Tref)	°C	52.8
Air flow rate	m <sup>3</sup> /h	162.7
Coefficient of performance (COP)	-	2.75 - M
Power absorbed at steady speed (Pes)	W	18
Heating time(th)	h.min	6 h 25
Reference temperature(Tref)	°C	52.5

2.3 DIMENSIONS AND COMPONENTS.

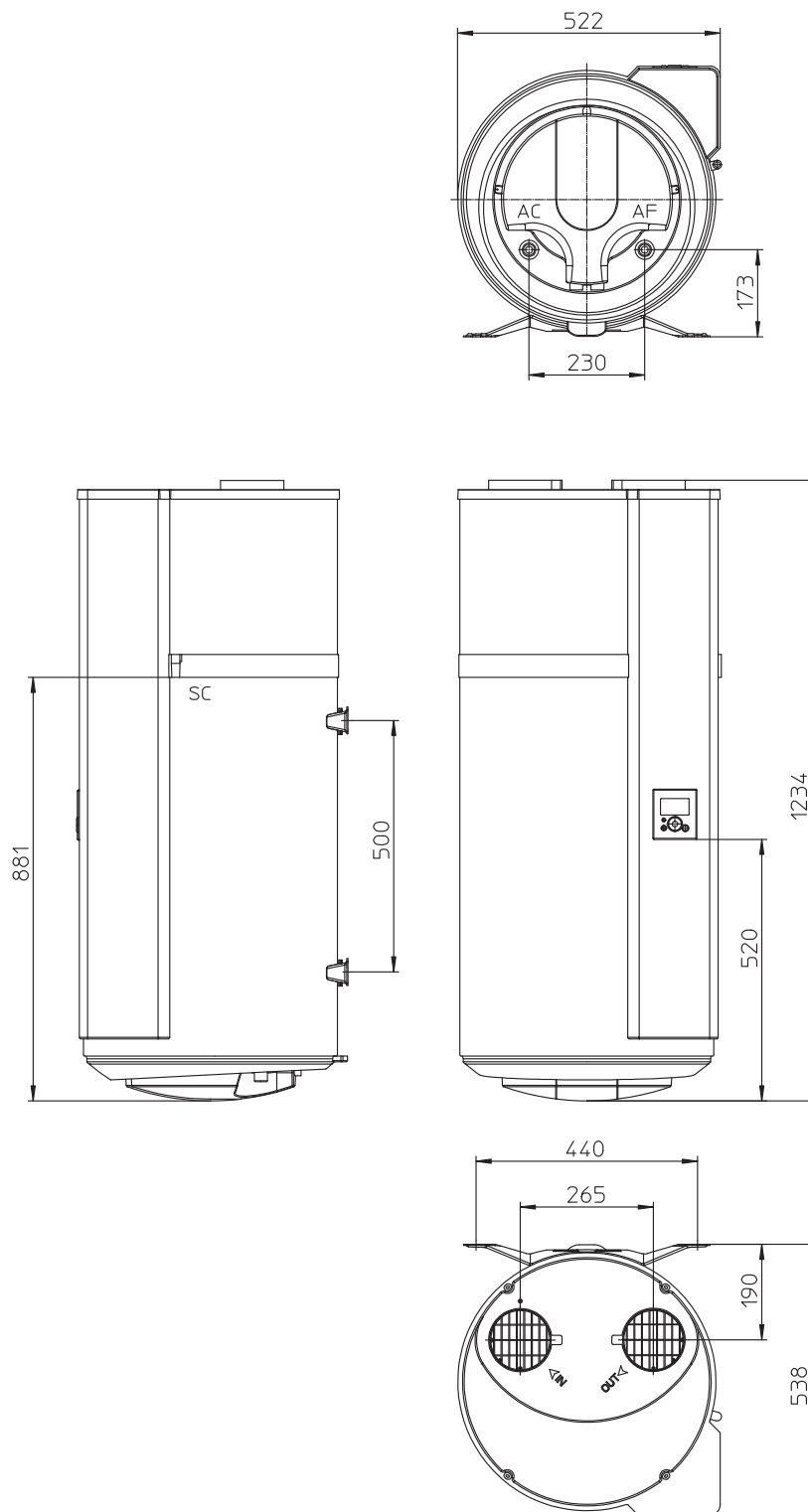

Key:

- AC - Domestic hot water outlet 3/4" M
- AF - Domestic cold water inlet 3/4" M
- SC - Condensate drain Ø 20

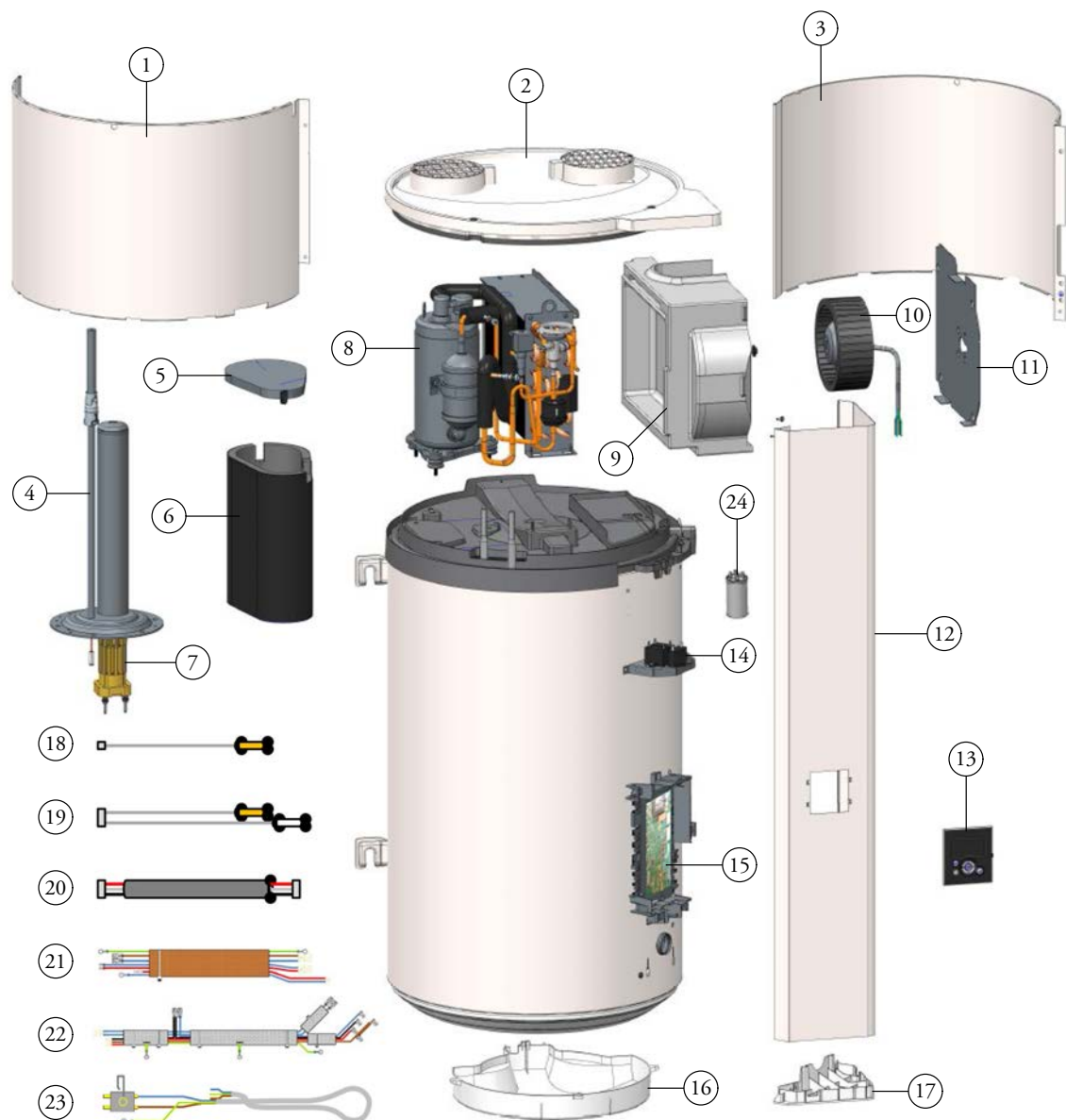

**Key:**

- 1 - Front cover
- 2 - Cover
- 3 - Rear cover
- 4 - Heating unit (Resistance + Anode)
- 5 - Casing cover
- 6 - Compressor casing
- 7 - Electrical resistance
- 8 - Compressor
- 9 - Fan casing
- 10 - Fan
- 11 - Fan support plate
- 12 - Front column
- 13 - Control unit
- 14 - Condenser 1.5-2.5-2.7 $\mu$ F
- 15 - P.C.B.
- 16 - Cap
- 17 - Bottom part cap
- 18 - Water probe wiring 1
- 19 - PDC probe wiring 2
- 20 - Interface wiring
- 21 - Electrical integration
- 22 - Compressor wiring
- 23 - Fan wiring + terminal block
- 24 - Condenser 10 $\mu$ F

**Not shown:** manual, dielectric connection, condensate draining pipe, safety unit.



# 3 INSTALLATION.

## 3.1 CHOOSING THE PLACE OF INSTALLATION.

Resistance of the wall	<ul style="list-style-type: none"> <li>Withstands a load of at least 300 kg (water heater fixing surface)</li> </ul> <p><b>Note:</b> only install a water storage tank under the water heater when this is positioned above in residential buildings.</p>	
<b>The installation area shall be suitable for protection index IPX1B, as set forth in IEC 64-8</b>		
	<b>Non-ducted or semi-ducted configuration</b>	<b>Ducted configuration</b>
Type of installation room	<ul style="list-style-type: none"> <li>Unheated room, characterised by temperature exceeding 5°C and preferably insulated from the home's heated rooms.</li> <li>Recommended room = underground or basement, room where the temperature is higher than 10°C all year round.</li> </ul>	<ul style="list-style-type: none"> <li><b>Room that is at least frost-free.</b></li> <li>Recommended room = living space (the heat loss from the water heater is not wasted), close to the outer walls.</li> <li>Do not install close to sleeping areas because of the noise produced.</li> </ul>
Room examples	<ul style="list-style-type: none"> <li>garage, boiler room (with the exception of rooms where type B generators are installed), basement floor, ironing room, etc.</li> </ul>	<ul style="list-style-type: none"> <li>laundry room, cellar, cupboard in entrance hall, etc.</li> </ul>
Volume of room where air is extracted	<ul style="list-style-type: none"> <li>Volume &gt; 20 m<sup>3</sup></li> </ul>	<ul style="list-style-type: none"> <li>/</li> </ul>
Temperature of water heater installation room	<ul style="list-style-type: none"> <li>from 5°C to 43°C.</li> </ul>	<ul style="list-style-type: none"> <li>&gt; 1°C.</li> </ul>
Air inlet temperature	<ul style="list-style-type: none"> <li>-5°C to 43°C.</li> </ul>	<ul style="list-style-type: none"> <li>-5°C to 43°C.</li> </ul>
Ceiling height	<ul style="list-style-type: none"> <li>&gt; 2.00 m.</li> </ul>	<ul style="list-style-type: none"> <li>&gt; 2.00 m.</li> </ul>
Surface area required	<ul style="list-style-type: none"> <li>2.10 m<sup>2</sup>.</li> <li>The wall must be perpendicular.</li> </ul>	<ul style="list-style-type: none"> <li>2.10 m<sup>2</sup>.</li> <li>The wall must be perpendicular.</li> </ul>

### RECOMMENDED CONFIGURATIONS.

- **1<sup>st</sup> configuration: installation without duct in unheated room (Volume > 20 m<sup>3</sup>) (Fig. 3-1).**

#### INTERNAL/INTERNAL parameter (Paragraph 4.5).

Examples of unheated rooms:

- Garage: Recovery of free calories released by car engine when turned off after running, or other electrical appliances operating.

- Laundry room: dehumidifying the room and recovery of waste calories from washing machines and tumble-dryers.

- Room in basement: recovery of free calories released by the floor and walls of the basement.

**Note:** observe the minimum distance indicated to prevent air recirculation.

**Note:** observe a space of 450 mm in front of the electrical appliance, so that the water heater can be accessed for maintenance work.

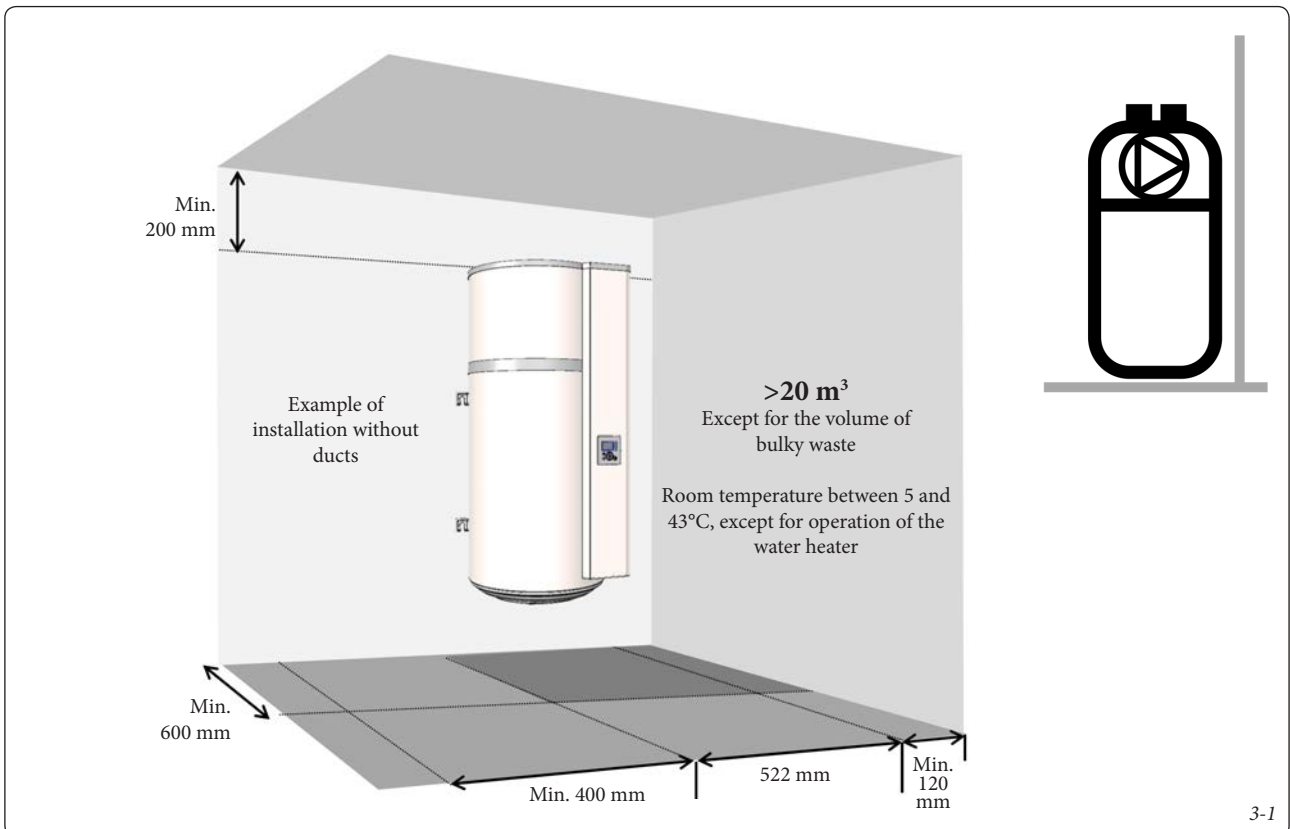

- **2<sup>nd</sup> configuration: installation in a heater or unheated room, with ducts** (Fig. 3-2).

**EXTERNAL/EXTERNAL parameter** (Paragraph 4.5).

Recommendations:

- Comply with maximum duct lengths (Paragraph 3.4).
- Use rigid or semi-rigid pipes.
- Provide air inlet and outlet grids to avoid ingress of foreign bodies. Note: manually shuttered air inlet and outlet grids are forbidden.

**Note:** observe a space of 450 mm in front of the electrical appliance, so that the water heater can be accessed for maintenance work.

**CONFIGURATIONS IN CERTAIN CONDITIONS (subject to assessment).**

- **Installation in unheated room, with 1 duct only (volume > 20 m<sup>3</sup>)** (Fig. 3-3).

**INTERNAL/EXTERNAL parameter** (Paragraph 4.5).

Possible consequence:

- In the event of installation with air intake in the same room and expulsion through a duct, the ventilation openings must be sized with a minimum diameter of 125 mm.

**Note:** in winter, the inlet air will be colder than that discharged by the water heater, which will increase room cooling.

**Note:** observe a space of 450 mm in front of the electrical appliance, so that the water heater can be accessed for maintenance work.

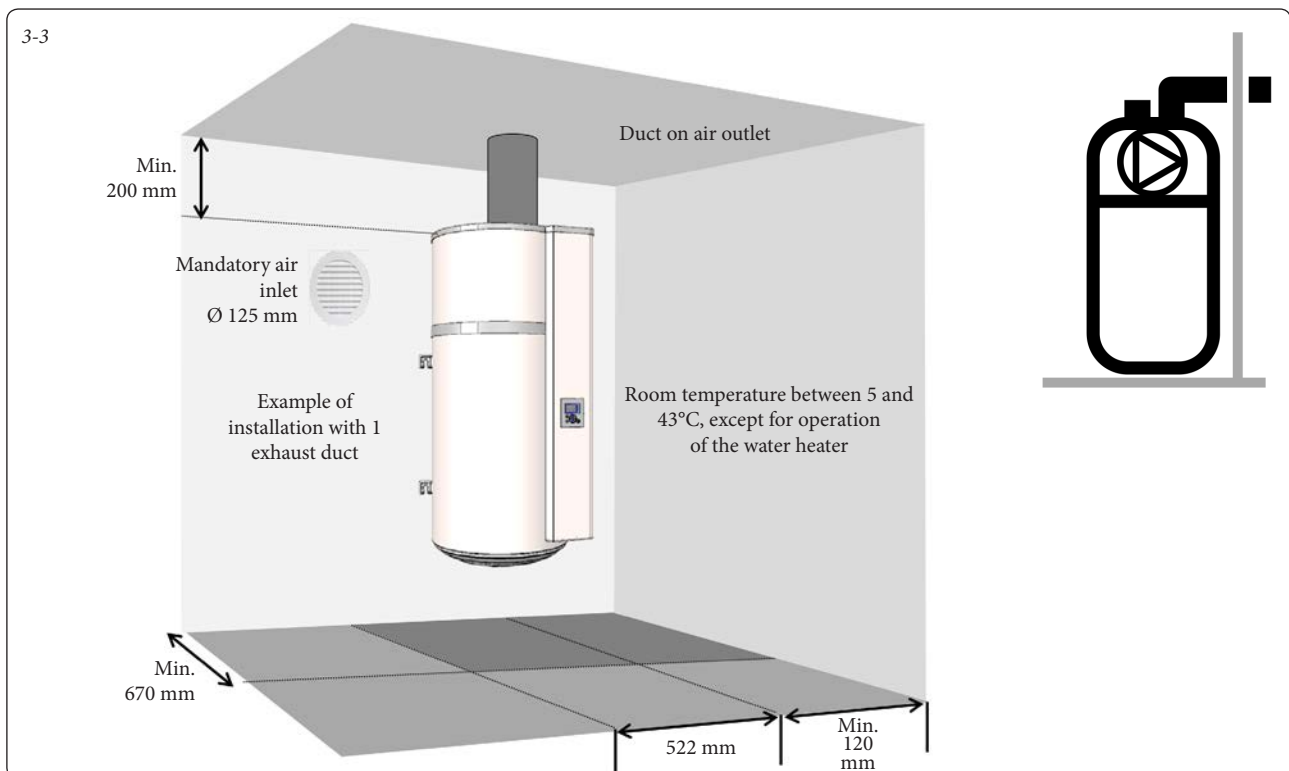
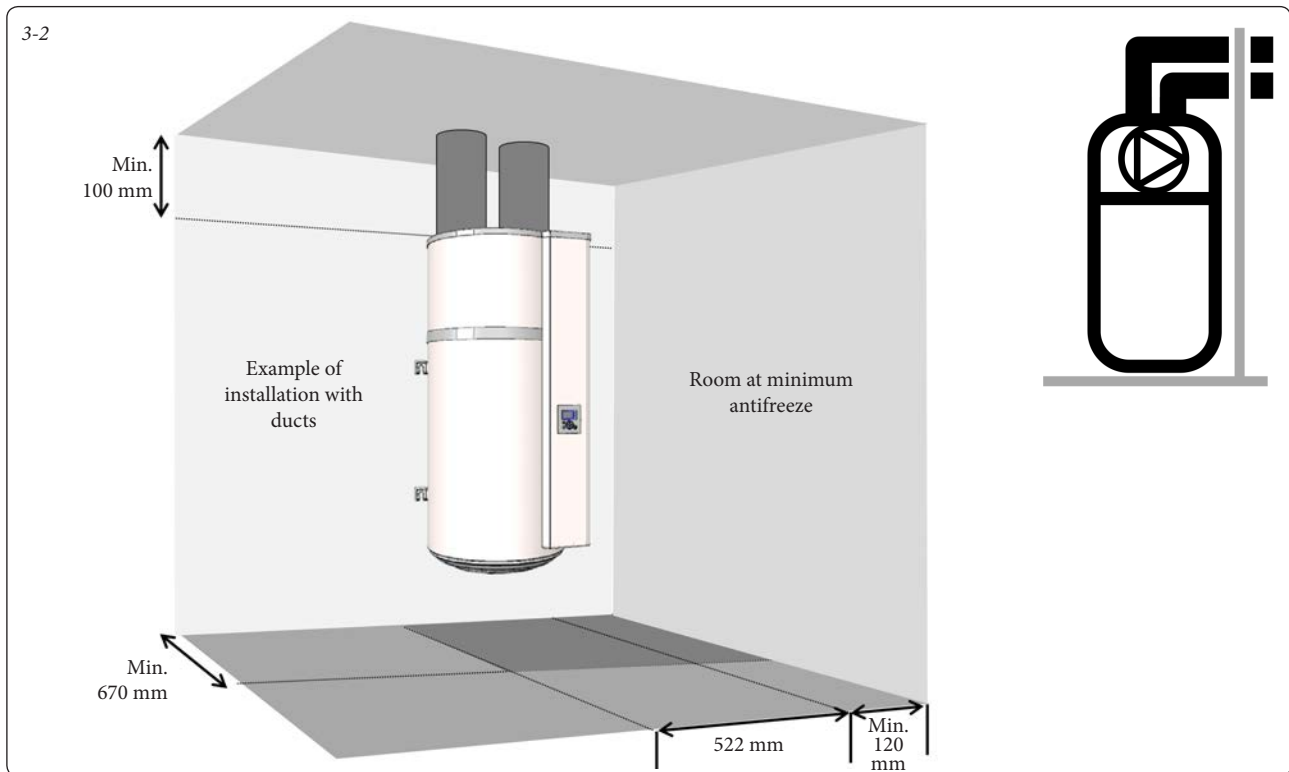

## FORBIDDEN CONFIGURATIONS.

Forbidden installation configurations	Associated risks
✘ The water heater takes air from a room containing a paid heat source used for heating this room.	Excessive system consumption: the water heater no longer uses free calories, but uses those produced by other devices connected to other energy sources.
✘ Connection to a controlled mechanical ventilation system (CMV).	The air flow rates in the thermodynamic water heater are incompatible with those of a CMV. Furthermore, the CMV ducts may convey greasy vapour and dust, potentially harmful for the duration in service of your water heater.
✘ Connection to an attic.	In the presence of inadequate insulation between the building and the relative attics, this type of installation may increase the thermal loss of the building. In extreme cases, condensate might form on the ceilings of the rooms under the attic due to its cooling. There is a greater risk from falling objects and dust ingress to the water heater in this configuration, which could reduce its life expectancy.
✘ duct which intakes air from the outside, conveying cold air inside.	Significant loss of the coefficient of performance (COP) and much greater cooling of the room.
✘ Connection to a geo-thermal system.	Excessive loss of load, and problems balancing the two fans in series. High risk of clogging the evaporator.

### Other prohibitions:

- Do not connect the device's fan to a tumble-dryer
- Avoid very dusty rooms
- Do not extract air containing solvents or explosive materials.
- Do not connect the device to a suction hood used to extract greasy or polluted air.
- Do not install the water heater in a room exposed to frost
- Do not place any objects on the water heater
- In non-ducted or semi-ducted configuration, do not place it in a room where an open chamber heat generator is installed (type B).

### 3.2 PRODUCT INSTALLATION.

- 1 - Take the water heater to the place of installation.  
The device has various handholds to help move it to the place of installation. Use the bottom and top handholds to carry the water heater to its place of installation.
- 2 - Open the packaging.
- 3 - Separate the boiler from the pallet and place it next to the hydraulic connection.  
**The water heater must be installed on a perpendicular wall ( $\pm 1^\circ$ ) or on smooth flat surface ( $\pm 1^\circ$ ).**

- 4 - If the wall is load-bearing (concrete, stone, bricks) (Fig. 3-4), anchor with  $\varnothing 10$  mm bolts or drill holes for  $\varnothing 10$  mm MOLLY bolts.
- 5 - If the wall is not load-bearing (Fig. 3-5) it is mandatory to put the water heater on a mount (optional). Put the water heat on the mount to trace the fixing points. Drill the holes and reposition the water heater. The top bracket must be secured (using a  $\varnothing 10$  mm anchor at least, depending on the wall) to prevent it from tipping over.

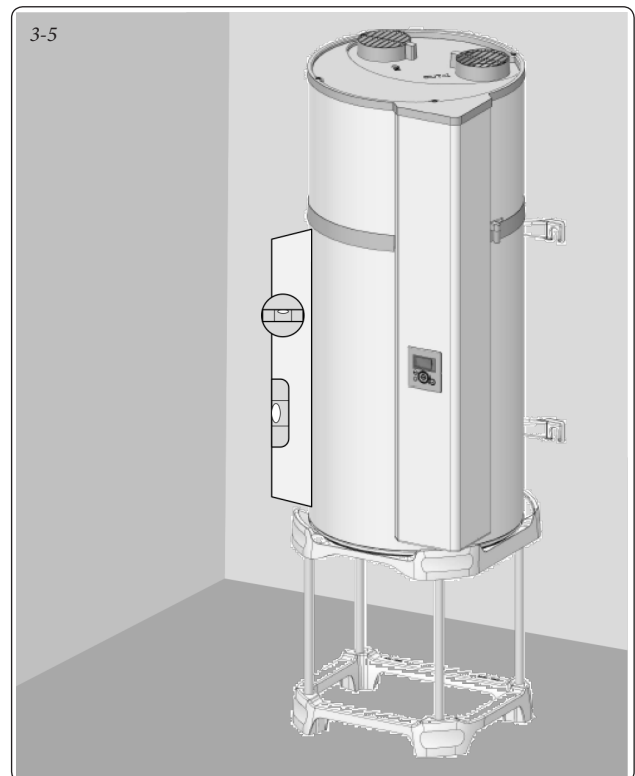
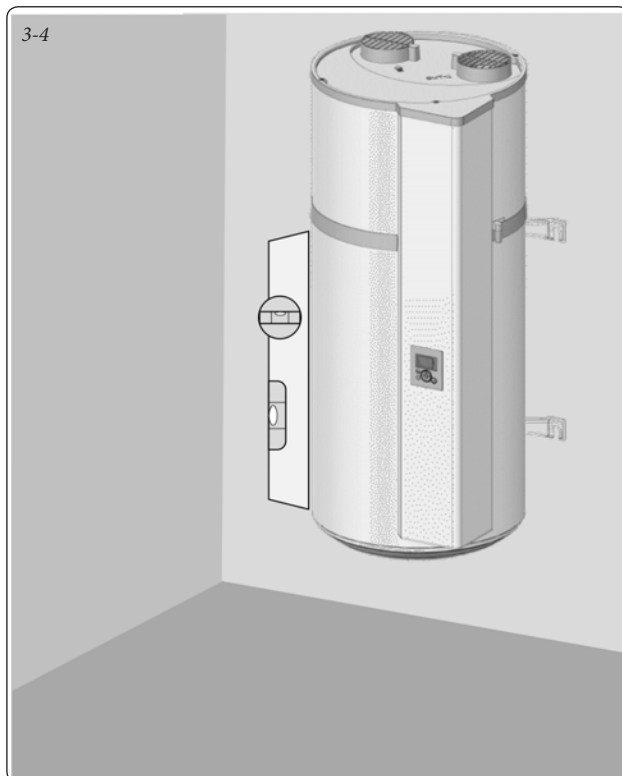

### 3.3 HYDRAULIC CONNECTION.

#### Connection to the cold water inlet.

Before connecting the water supply, it is essential to clean the pipes thoroughly, to avert the risk of any metal or other particles entering the water heater tank.

It is mandatory to install a safety device, set to be triggered at 0.7 MPa (7 bar) (not supplied with the water heater), sized 3/4", compliant with standard EN1487 as amended, and in any case compliant with local regulations in force, to be fitted to the cold water inlet of the water heater. The safety device must be protected from ice.

**Note:** no hydraulic fittings (stop valve, pressure reducer, etc.) must be placed between the safety unit and the cold water inlet of the water heater, except for a copper pipe.

Connect the safety unit to an open drain pipe, in a frost-free environment, with a permanent downward gradient, to remove any expansion water generated by the heating process or drainage water coming from the water heater itself. The pipes used must withstand a temperature of 100°C and a pressure of 1 MPa (10 bar).

When the inlet water pressure exceeds 0.5 MPa (5 bar), a pressure reducer is required (not supplied as standard).

**The pressure reducer must be installed at the beginning of the main distribution network.** A pressure of 0.3 to 0.4 MPa (3 and 4 bar) is recommended.

#### Connection to the hot water inlet.

**Note:** do not connect the hot water directly to copper pipes, in order to avoid copper/iron galvanic coupling (risk of corrosion). It is therefore obligatory to fit a dielectric fitting on the hot water outlet (supplied with the device).

**Any corrosion on the threads of the hot water outlet fitting, due to the fitting supplied not being used, shall void the product warranty.**

In the event pipes in synthetic material have been used (e.g.: PER), we strongly recommend installing a thermostatic control device water heater outlets and set it according to the performance of the material used.

**Note:** the use of D.H.W. recirculation is not feasible: this method causes water destratification in the tank and makes the heat pump and the electrical resistance work more.

#### Removing the condensate.

**Note:** cooling of the circulating air in contact with the evaporator results in the water contained in the air condensing. The condensed water flowing down the back of the heat pump must be removed from it and conveyed into suitable plastic pipes.

On the basis of air humidity, **up to 0.25 l/h of condensate may be formed.** The condensate run-off must not be conveyed into the drain, since the ammonia fumes that flow back from the drain could damage the heat exchanger fins and parts of the heat pump.

**It is therefore obligatory to fit a siphon for the discharge of waste water (do not use the pipe supplied under any circumstances to make a siphon).**

### 3.4 AIR INTAKE CONNECTION.

When the volume of the room where the water heater is installed is less than 20 m<sup>3</sup>, the device may be connected to air ducts with 125 mm diameter. If these ducts are not insulated, condensate might form in them during device operation. **It is therefore essential to choose insulated air ducts.**

Poor-quality air ducts (crushed, too long, or with too many bends, etc.) may cause a loss of performance.

**Therefore flexible ducts are definitely not recommended.**

**Note:** if there are connections to the ducts, adjust fan settings accordingly.

**Note:** the overall head loss on ducts and fittings for discharge and intake of air **must be less than 70 Pa.** Calculate the pressure drop using the table below, according to the proposed duct accessories.

For installation without ducts, the direction of the grids can be altered to direct the air flows. To do this, unscrew the grids and screw them back in one of the other 2 positions provided. It is forbidden to direct the grids facing each other (Fig. 3-6).

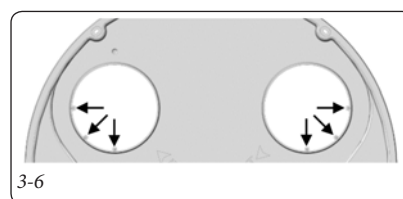

### 3.5 ELECTRICAL CONNECTION.

**Note:** the water heater can be electrically connected only after being filled with water.

**Note:** do not fit a programming clock or timing devices that may interrupt the device's supply voltage upstream of the water heater's electrical connection.

The water heater can be connected and operated only with single-phase 230V AC power supply. Connect the water heater with a cable with conductors having a cross-section of at least 1.5 mm<sup>2</sup>. Installation shall consist of:

- A circuit breaker or 16A multi-pole fuse with contacts compliant with regulations in force.
- A 30 mA differential circuit breaker.

If the power cable is damaged, for safety reasons it must be replaced by the manufacturer, the after-sales service or similarly qualified staff.

**Note:** earthing is obligatory.

Do not connect the supply voltage directly to the electrical resistance.

The safety thermostat with which the electrical integration is fitted must not be tampered with; if required, it may be repaired/serviced exclusively by skilled and qualified staff, according to the instructions provided by Immergas. **Failure to comply with this clause shall void the warranty.**

The device must be installed in compliance with the provisions of the regulations in force.

Number of bends	Overall length of the ducts* with air outlet and inlet mounted on the wall	Overall length of the ducts** with air outlet and inlet mounted on the wall
0 bends	10 m	21 m
1 90° elbow fitting	8 m	17 m
2 90° elbow fittings	6 m	13 m
(*) semi-rigid ducts - (**) rigid ducts		

### Photovoltaic self-consumption contact.

The water heater is equipped with a contact to fully exploit the electricity produced by the PV system, in order to accumulate thermal energy within the storage tank (self-consumption). Having an inverter/electronic device which supplies a signal when PV production exceeds a certain value, when this contact is closed the water heater is triggered in heat pump mode to heat the DHW up to 62°C. When the photovoltaic contact opens, the system returns to the previous settings.

The instructions for removing the front cover and for accessing the terminal block can be found in paragraph 5.5.

The photovoltaic station must be wired to the appropriate connector provided (I1) (Fig. 3-10). To pass the photovoltaic station's connection cable, a hole must be drilled in the bottom cap; the point where the hole is to be drilled is marked (Fig. 3-8).

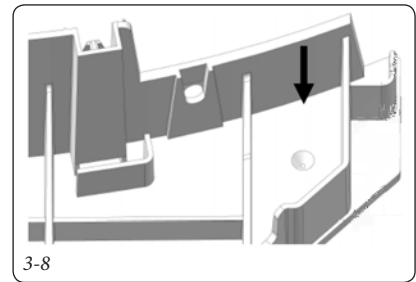

### Wiring diagram

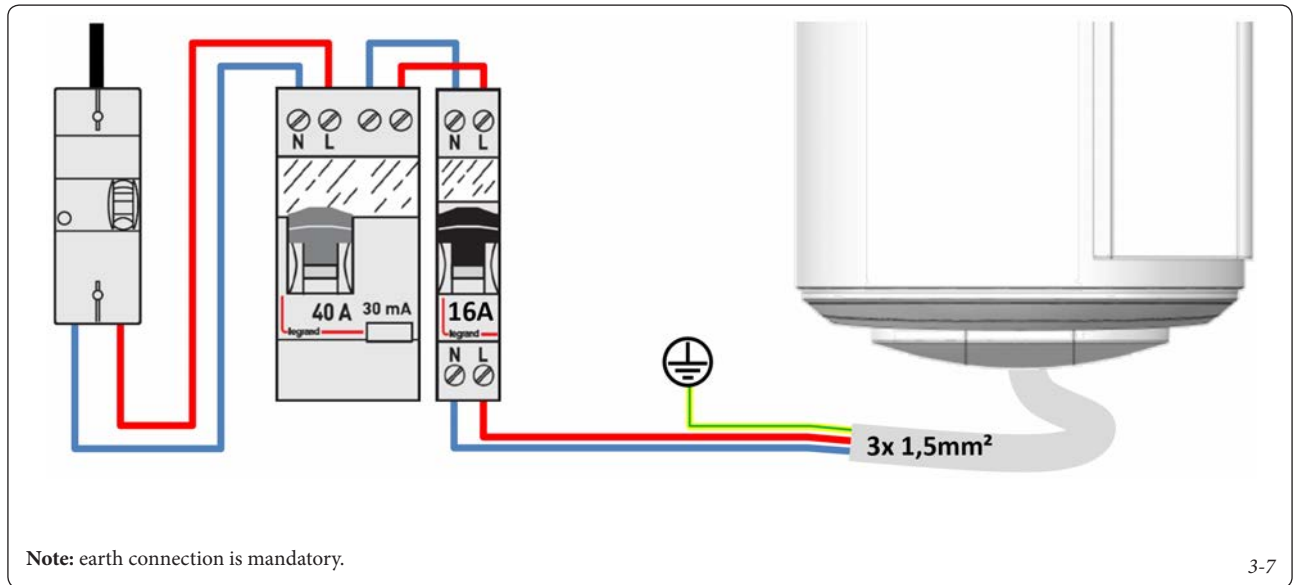

### Example of connection to a photovoltaic system

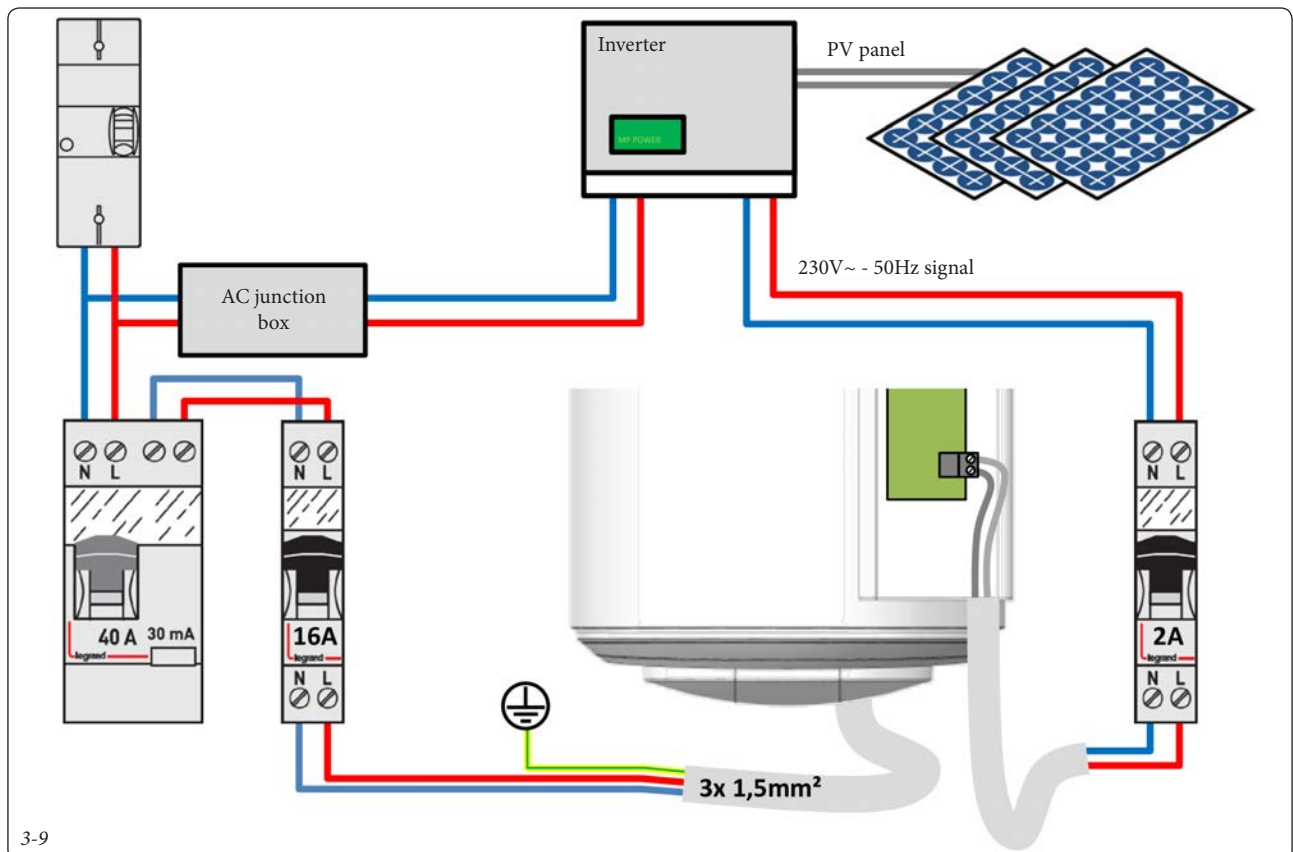

### 3.6 WATER HEATER WIRING DIAGRAM.

3-10

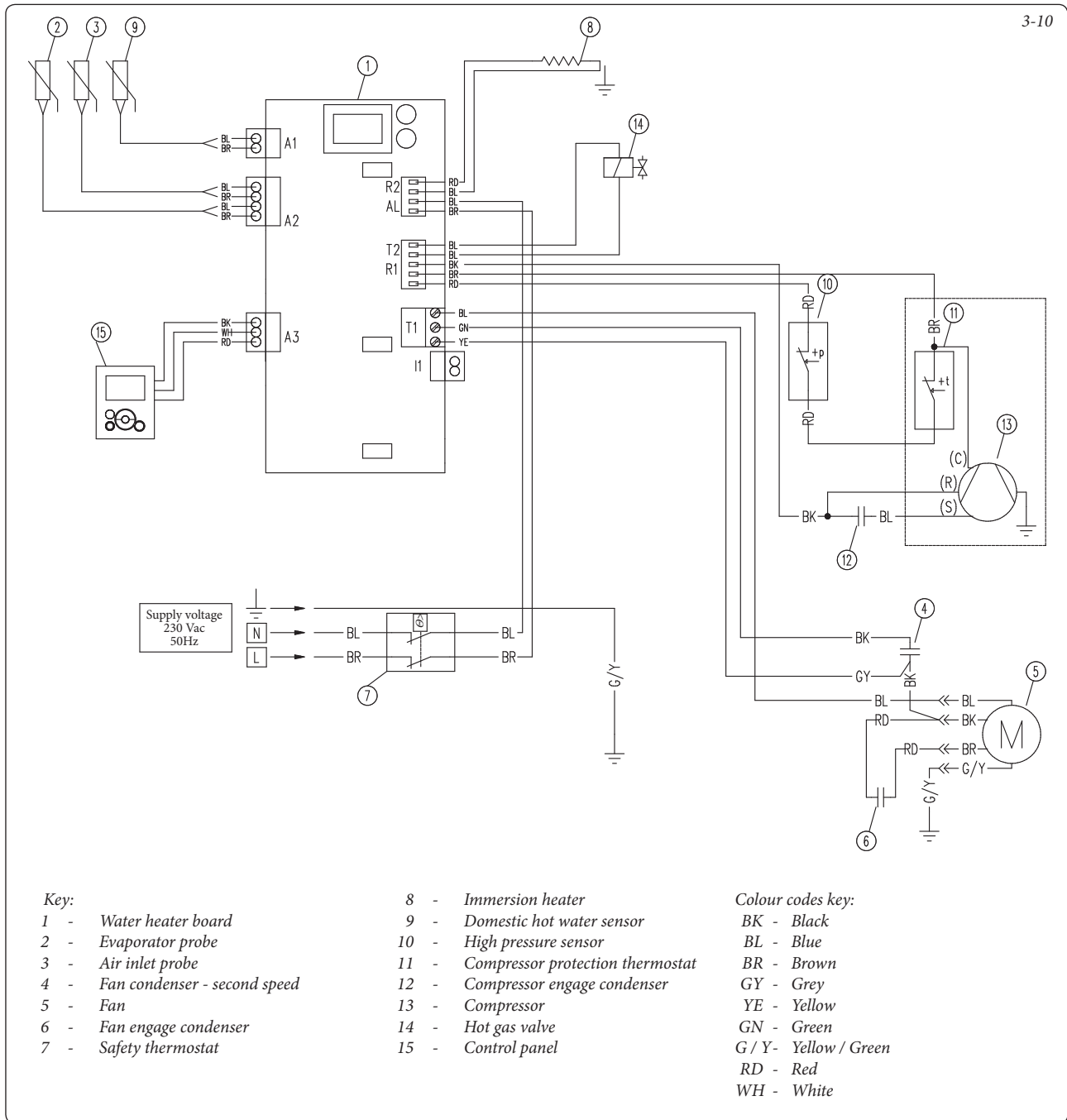

### 3.7 COMMISSIONING.

#### Filling the water heater.

- Open the hot water taps.
- Open the cold water tap on the safety device (ensure the unit emptying valve is closed).
- Run the hot water from the taps then close them: the water heater is now full.
- Check water tightness of the pipe fittings.
- Check correct operation of hydraulic devices by opening the discharge valve of the safety device to eliminate any residues from inside the relief valve.

#### Commissioning.

- Note:** if the water heater has been tilted, wait at least 1 hour prior to commissioning.
- Turn on the water heater.
  - Check that the screen (4 Fig. 4-1) does not display errors.
  - During first power-up, the adjustment instructions are displayed on the screen. Follow the on-screen instructions carefully to set parameters (date and time, air ducts, installation, photovoltaic, operating time slots, anti-legionella system).
  - Setting the programming time slots:  
In the "heating mode" menu, select the "HP 24 hours, programmable resistance" or the "programmable HP and resistance" option where you have the choice of setting two time slots.

The start time of the time slot and the duration of the slot can be set with the arrow keys and ok to confirm. The total minimum and maximum heating periods between the two time slots are respectively 12 and 20 total hours.

- After setting the parameters, check operation of the water heater.

To return to the settings, refer to the "System Settings" or "Setup Parameters" sections.

# 4 PARAMETER SETTINGS / USE.

## 4.1 REMOTE PANEL.

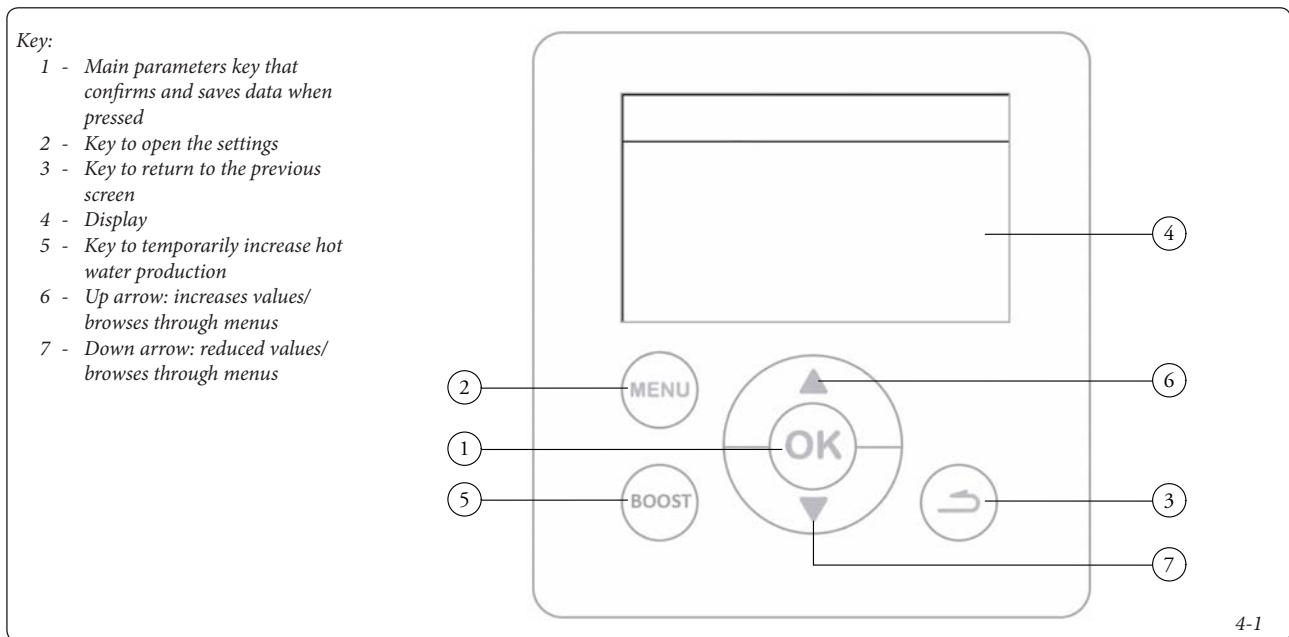

## 4.2 DESCRIPTION OF THE SYMBOLS.

Symbol	Description
<b>BOOST</b>	Forced start set
	Absence set / in progress
	Hot water set-point temperature
	Stand-by
	Electrical integration in operation
	Heat pump in operation
	Anti-legionella cycle
	Reception of a signal at the inlet of the photovoltaic system

- **BOOST function (BOOST).**  
Press the key (5 Fig. 4-1) to increase the production of hot water regularly. Set the number of the BOOST operation days (from 1 to 7). At the end of the chosen period, the water heater resumes operation with the initial settings. The BOOST can be interrupted at any time: **BOOST pause**.

## 4.3 MAIN MENU.

Open the settings by pressing the "Access key" (MENU) (2 Fig. 4-1) and follow the on-screen instructions (4 Fig. 4-1). Browse through the menu by pressing the "down arrow" (7 Fig. 4-1) to reduce the values or the "up arrow" (6 Fig. 4-1) to increase the values. Press the main key in the centre (1 Fig. 4-1) to confirm.

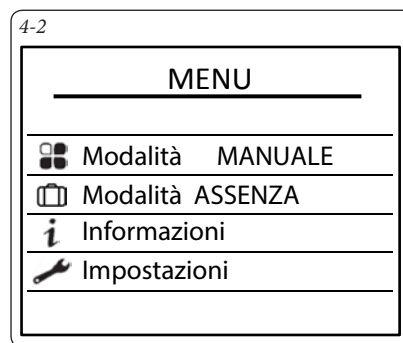

- **OPERATING mode (gear icon).**  
Choose the operating mode. Select AUTO or MANUAL (see paragraph 4.6 "Operating modes").
- **ABSENCE mode (absence icon).**  
Program an absence. It allows you to indicate in the water heater:
  - a permanent absence starting from the current date;
  - a programmed absence (set the start date of the absence and the end date). On the eve of your return, an anti-legionella cycle is activated. In this period, the water temperature is kept above 15°C. The function can be interrupted at any time: **Disable absence**.

- **Information (i icon).**
  - Display the energy savings. It allows you to view the utilisation rate of the heat pump and electrical integration over the last 7 days, the last 12 months, from commissioning.
  - Display power consumption. It allows you to view energy consumption in kW/hour, in recent days, in recent months, in recent years.
  - Display the budget parameters. It allows you to view all the settings recorded in the water heater.
- **Settings (wrench icon).**
  - Set the time and date. Set the day and then confirm. Then set the month, year, hour and minutes.
  - Set the operating time slots. It lets you define the time slots in which the device is authorised to start.
  - Set the language. French, English, Dutch, Spanish, Portuguese, German, Italian and Polish.
  - Connections. It allows you to turn off the support of electrical integration.

#### 4.4 SYSTEM SETTINGS.

Access to the system settings: (MENU) + Settings.

- **Date and time.**

Set the day and then confirm. Do the same for the month, year, hour and minutes.

- **Heating mode.**

This parameter defines the operating time slots of the heat pump and of the electrical integration according to the hot water requirements:

**24/24 continuously** Start at any time of the day.

**Programming** Start in scheduled periods.

- **Setting the programming time slots.**

In the “heating mode” menu, select the “HP 24 hours, programmable resistance” or the “programmable HP and resistance” option where you have the choice of setting two time slots. The start time of the time slot and the duration of the slot can be set with the arrow keys and ok to confirm. The total minimum and maximum heating periods between the two time slots are respectively 12 and 20 total hours.

- **Language.**

Possible settings in French, English, Dutch, Spanish, Portuguese, German, Italian and Polish.

- **Connections.**

It allows you to activate or not the electrical integration support. If it is off, the device will never use the electrical integration; in case of low temperatures, a shortage of hot water is possible.

#### 4.5 PARAMETERS TO BE ADJUSTED UPON INSTALLATION.

(If not set at the time of commissioning)

The installation parameters can be accessed in INSTALLER MODE.

Press “Menu” (2 Fig. 4-1) and “Up arrow” at the same time for 5 seconds (6 Fig. 4-1).

To exit the installer mode, proceed in the same way or wait for 3 minutes.

Access to the system settings: (MENU) Settings

- **Block**

This mode enables continuous operation only with the boost.

- **Hot water.**

- **Heating mode**

This parameter defines the operating time slots of the heat pump and of the electrical integration according to the hot water requirements:

HP 24h / ELEC 24h	Start at any time of the day
HP 24h / ELEC Prog	Start the heat pump at any time of the day, start the electrical integration at the programmed times
HP Prog / ELEC Prog	Start in programmed periods.

- **Anti-legionella.**

It allows you to turn on the water disinfection function several times a month. The water temperature reaches 62°C 1-4 times a month depending on the desired setting.

- **PV Photovoltaic system.**

This parameter is used to activate the device coupled with a photovoltaic system. This operating mode generates the forced start of the heat pump when the water heater receives a signal coming from the photovoltaic system. The setting automatically returns to the previously selected mode after 30 minutes if the photovoltaic system signal is lost. While receiving the signal the set point temperature is automatically set at 62°C (not adjustable).

- **Emergency mode.**

Enabling this mode allows continuous operation only with the electrical integration.

- **Additional Electricity BOOST (electrical integration).**

It allows you to activate or not the electrical integration support. If it is off, the device will never use the electrical integration; in case of low temperatures, a shortage of hot water is possible.

- **Ducting (aeraulic operation).**

This parameter defines the aeraulic connection type realised:

Inside / Inside	Suction and return not connected to air ducts (ambient air)
Outside / Outside	Suction and return connected to air ducts (outside air)
Inside / Outside	Return connected to an air duct (semi-ducted)

#### 4.6 SELECTING THE OPERATING MODE.

Press (MENU) to access the Mode menu.

- **In AUTO mode.**

This operating mode automatically manages the energy choice that allows maximum savings while guaranteeing an adequate comfort in terms of hot water. The water heater analyses the consumption of the previous days to adapt the production of hot water according to needs. It reacts to unexpected events to ensure hot water by switching the heat pump on. Therefore, the set point temperature is automatically adjusted between 50 and 62°C according to the consumption profile. The Water heater operates preferably through the heat pump. The electrical integration can be automatically selected to ensure a sufficient volume of hot water.

- **MANUAL mode.**

This mode allows you to define the desired amount of hot water by choosing the set point. This set point is also represented as an equivalence of number of showers (about 50 litres of hot water).

If the ECO mode is not active, the water heater favours operation of the heat pump only. However, if the air temperature is low or consumption is substantial, the electrical integration can be authorised as a support at the end of heating to reach the temperature set. If the ECO mode is active, the water heater works only with the heat pump with an air temperature ranging from -5 to +43°C. Therefore electrical integration is not authorised at the time of heating. This feature optimises the savings, but can cause hot water shortages. Regardless of the ECO adjustment, if the air temperature exceeds the operating time slots, the electrical integration will be automatically selected to ensure a sufficient volume of hot water.

- **BOOST mode.**

This mode activates the heat pump and electrical integration simultaneously at the maximum set point of 62°C.

- **ABSENCE mode.**

This mode maintains the domestic hot water temperature above 20°C using the heat pump. Electrical integration can be activated if the heat pump is not available.

#### 4.7 DISPLAY THE INFORMATION

Open the “Info” menu to:

- **Display the energy savings.**

It allows you to view the utilisation rate of the heat pump and electrical integration over the last 7 days, the last 12 months, from commissioning.

- **Display the power consumption.**

It allows you to view energy consumption in kw/hour, in the last 7 days, in the last 12 months, from commissioning.

- **Display the budget parameters.**

It allows you to view all the settings recorded in the water heater.



## 5 RECOMMENDATIONS - MAINTENANCE AND REPAIRS.

### 5.1 ADVICE FOR THE USER.

You must empty the water heater if the absence mode cannot be used or when the device is not on. Proceed in the following way:

- Stop the supply voltage.
- Close the cold water inlet tap.
- Open a hot water tap.
- Put the safety valve in the drain position.

#### Important note - End of the device's service life:

- At the end of its service life, the device must be taken to a sorting centre for electrical and electronic equipment for recovery of fluids. Do not dispose of the device with household waste, but dispose of it in the collection centres provided, where it can be recycled. Check your local collection service to find out about existing waste collection centres.



- It is forbidden by law to discharge the coolant contained in the device into the atmosphere. Degassing operations are strictly forbidden, and may be hazardous.

**Note:** the GWP (Global Warming Potential) of R134a is 1430.

### 5.2 HOUSEHOLD MAINTENANCE.

The user must perform some minor home maintenance operations on the water heater: act on the safety valve once or twice a month to remove any limestone deposits and ensure it is not blocked.

Regularly check that there are no alarms on the display. If there are any alarms, contact the authorised local service centre to address the faults.

It is recommended to treat water with a softener in the areas where there is a high amount of scale (Th>20°F). **Water hardness must remain above 15°F.** The softener does not lead to warranty derogations, provided it is dosed in a workmanlike manner and regularly maintained. Water treatment must comply with the provisions of UNI 8065.

### 5.3 MAINTENANCE BY APPROVED PROFESSIONALS.

**The device must be checked by a professional once a year, in order to ensure its long-term performance.**

- Disconnect the device from the electricity (circuit-breaker, fuses, etc.)
- Drain the tank:
  - close the cold water inlet tap of the safety unit,
  - open a hot water tap,
  - put the safety valve in the drain position.
- Remove the bottom cover.
- Disconnect the wires from the thermostat terminals.
- Dismantle the heating unit.
- Replace the magnesium anode. The magnesium anode has to be changed every 2 years or as soon as its diameter is less than 10mm.
- Remove the scale deposited as sludge or flakes in the bottom of the tank every two years, and carefully clean the casings of the heating elements and thermostat. Do not scratch or remove the scale attached to the walls, as this could affect the coating. Residues may be removed using a water and dust vacuum cleaner.
- Refit the heating unit with a new seal, carefully and gradually tightening the nuts (cross-tightening).
- Fill the water heater by leaving a hot water tap open, if the water flows it indicates that the water heater is full.
- Check the water tightness of the seal and only then replace the thermostat and its fittings, and reconnect the supply voltage.
- The next day, check the water tightness of the seal again and gently tighten the nuts again if necessary.
- Check the electrical connections.
- Check that the temperature probe is properly positioned in the sample point near to the electrical integration (the probe must be at the bottom of the sample point).
- Once a year check that the water heater is connected to the ducts. Check that the ducts are properly positioned and are not obstructed.
- Once a year check that there are no loose wires in the internal and external wiring and that all connectors are in place.

- Once a year check that the electrical integration works properly by measuring the output.
- Every 2 years check the heat exchange of the heat pump.
- Every 2 years check that the fan works at two speeds and the hot gas valve.
- Every 5 years check the coolant is charged.

#### Evaporator:

- The cleanliness of the evaporator and the fan must be checked **every 2 years**. Clogging of these components may reduce the performance of the heat pump.
- Unscrew and remove the top cover to access the evaporator. The front cover may also be removed if necessary.
- If necessary, the evaporator and the fan are to be cleaned with a soft bristled brush. Brush the evaporator very gently to avoid damaging its fins. If the fins are folded, straighten them using a suitable brush.

**Note:** always disconnect the device from the power supply before starting any work.

#### Expansion valve:

- Only a refrigeration engineer is permitted to access the expansion valve adjustment screw. If the expansion valve is adjusted without approval from the manufacturer, the product warranty shall be voided.
- Generally speaking, it is not recommended to change the expansion valve setting before all other repair solutions have been exhausted.

#### Condensate draining pipe:

- Once a year check cleanliness of the condensate draining pipe. Any pollution (dust) in the room may in fact cause deposits in the condensate recovery tank. These deposits may block the condensate draining pipe and cause excessive accumulation of water in the tank, which could lead to malfunctions.

#### 5.4 TROUBLESHOOTING SUPPORT.

##### Control panel alarm codes

Errors can be suspended or reactivated by pressing "OK".

This action also stops the buzzer.

Error Code	Cause	Consequences	System status / Solution
W.03	<b>Defective water temperature probe (sample point)</b>	No possible warming up	Check the connections or replace the probe (reference A1).
W.07	<b>No water in the storage tank or ACI connection open</b>	No warming up	No water in the storage tank. Check the thread connection (reference AC), conductivity of the water.
W.09	<b>Water temperature too high (&gt; 80°C)</b>	Risk of mechanical safety device activation No warming up	Check the connections and the position of the probe (reference A1). Make sure the integration is not piloted permanently If necessary, reset the mechanical safety device and contact the installer.
W.15	<b>Date and time not set</b>	HP stoppage. If PROG	Enter date and time.
W.19	<b>0V electrical connection</b>	Complete shut-down	Check the electrical connection to the mains. The supply voltage must be permanent.
W.21	<b>Faulty air inlet temperature probe.</b>	HP stoppage. Heating with electrical integration	Check the connections or replace the probe (reference A2).
W.22	<b>Faulty evaporator temperature probes</b>	HP stoppage. Heating with electrical integration	Check the connections or replace the evaporator probes (reference A2). Check correct operation of the fan.
W.25	<b>Pressure switch alarm (faulty high pressure)</b>	HP stoppage. Heating with electrical integration	Ensure the air temperature has not exceeded 43°C. If the mode key is pressed, the fault resets, contact the installer.
W.28	<b>Defrosting malfunction</b>	HP stoppage. Heating with electrical integration	Check the connections or replace the coil (reference T2). Check operation of the fan. If the mode key is pressed, the fault resets, contact the installer.
W.301	<b>Inefficient HP heating</b>	HP stoppage. ELEC heating.	Check operation of the fan and ensure the air flow is correct. Check the coolant gas is charged.
W.302	<b>Inefficient HP heating</b>	HP stoppage. ELEC heating.	Check operation of the fan and ensure the air flow is correct. Check the coolant gas is charged.
W.303	<b>Faulty pressure switch</b>	HP stoppage. ELEC heating.	Check the coolant gas is charged. If it is charged, replace the pressure switch.
W.304	<b>HP deviation</b>	HP stoppage. ELEC heating.	Check the coolant gas is charged.
W.305	<b>Probes waste deviation</b>	HP stoppage. ELEC heating.	Check the connections (A2) and the position of the air probe and the evaporator probe. If necessary, replace the probe bundle.

### 5.5 WORK ON THE WATER HEATER.

#### Accessing the electronic components.

**Note:** always disconnect the device from the power supply before starting any work.

- Remove the four screws from the cover with a screwdriver (Fig. 5-1).
- Pull the column to release it and then extract it from the bottom cap (Fig. 5-2).
- Unscrew the 2 screws on the cover (Fig. 5-3).

#### Accessing the heat pump compartment.

**Note:** always disconnect the device from the power supply before starting any work.

- Unscrew the 2 screws on the front cover (Fig. 5-4).
- Rotate the cover to the left to unlock it (Fig. 5-5).
- Lift the cover to remove it (Fig. 5-6).

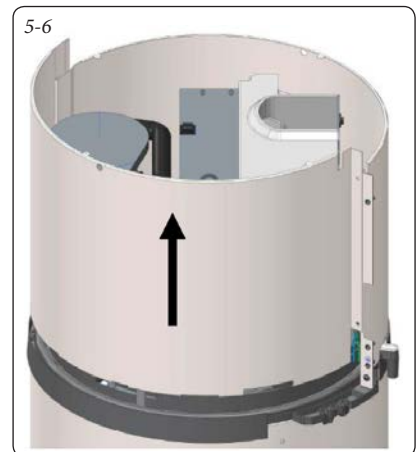
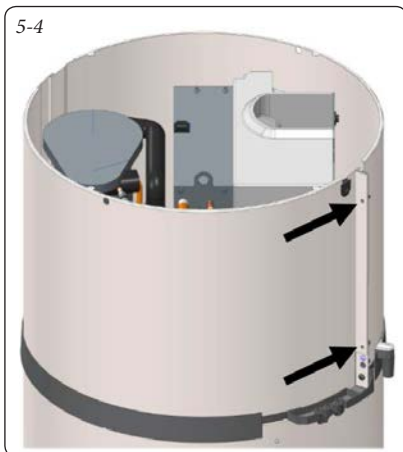
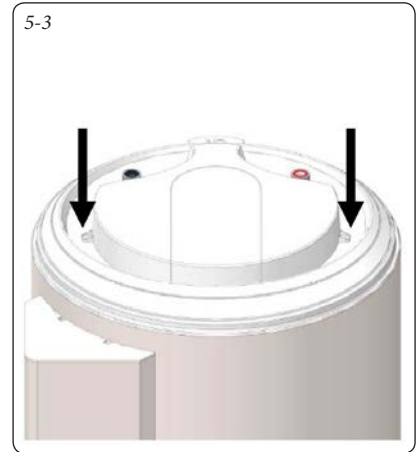
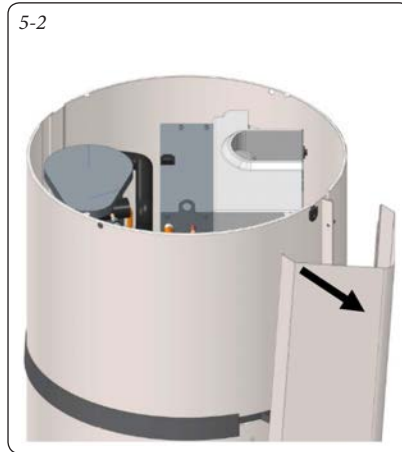
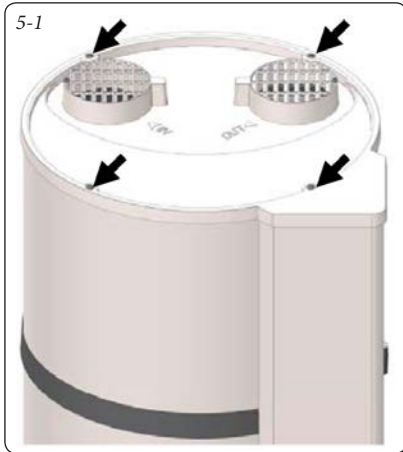

**5.6 QUICK FAULT DIAGNOSIS  
FOR USE CARRIED OUT BY A  
PROFESSIONAL TECHNICIAN.**

Fault detected	Possible cause	Diagnosis and solution
<b>Water not hot enough</b>	Delivery temperature on a value that is too low.	Adjust the delivery temperature to a higher value. Refer to the settings menu.
	Heating element or its wiring partially not working.	Check the resistance of the heating element on the connector of the electrical bundle and the good conditions of the bundle itself.
<b>No warming up. No hot water.</b>	No storage tank supply voltage: fuses, wiring, etc.	Check that the storage tank's power cables are live.
<b>Poor flow of the hot water tap.</b>	Safety valve damaged or clogged.	Replace the safety device.
<b>Continued loss of water to the level of the safety unit outside the heating period.</b>	Network pressure too high.	Make sure the outlet pressure of the water meter does not exceed 0.5 MPa (5 bar), otherwise install a pressure reducer set at 0.3 MPa (3 bar) at the beginning of the water mains.
<b>The electrical integration does not work.</b>	Faulty electrical thermostat.	Replace the thermostat.
	Faulty heating element.	Replace the heating element.
<b>Outflow of condensates.</b>	The storage tank is not properly levelled.	Ensure that the storage tank is placed on a flat surface.
	Condensate flow obstructed.	Clean (see the "maintenance carried out by an authorised professional" paragraph). Check there is no siphon on the drain pipe.
<b>Presence of odours.</b>	There is no siphon.	Install a siphon.
	There is no water in the siphon.	Fill the siphon.
<b>Emission of vapour during the bleeding phase.</b>		Disconnect the supply voltage and contact the installer.
<b>Loud boiling noise.</b>	Presence of scale in the storage tank.	Descale it.
<b>Another kind of malfunction.</b>		Contact the after-sales service for any other kind of malfunction.

**Note:** Do not connect the supply voltage directly to the electrical resistance.

**5.7 AFTER-SALES SERVICE.**

Only use original spare parts. Specify the exact type of water heater and serial number for any order.

**Operations on electrical parts must be performed by skilled and qualified staff pursuant to the legislation in force.**

If the power cable is damaged, for safety reasons it must be replaced by the after-sales service or similarly qualified staff.

Scope of application of the warranty.

**5.8 SCOPE OF APPLICATION OF THE WARRANTY.**

The following faults are excluded from this warranty:

• **Abnormal environmental conditions:**

- Various damages caused by impact or falling during handling after leaving the factory.
- Placement of the device in a location subject to frost or bad weather (humidity, aggressive or poorly ventilated rooms).
- Use of water with features that do not comply with those set forth by the regulations in force on the matter.

- Water pressure above 0.5 MPa (5 bar).
- Electrical power with significant voltage peaks (mains, lightning, etc.).
- Damage from undetectable problems caused by choice of location (places difficult to access) and that could have been avoided if the device had been repaired immediately.
- **System does not comply with regulations, standards, professional rules, especially:**
  - Missing or incorrectly fitted new safety unit, modification of calibration, etc.
  - Insulating sheath (cast iron, steel or insulating) missing on hot water connection pipes, which could cause their corrosion.
  - Faulty electrical connection: incorrect earthing, inadequate cable section, connection of flexible cables without metal terminals, failure to comply with the wiring diagrams provided by the Manufacturer.
  - Switching on the device without first filling it (dry heating).
  - Positioning the device without considering the instructions in the manual.
  - External corrosion caused by poor sealing on pipes.

• **Incorrect maintenance:**

- Abnormal formation of scale on heating elements or safety units.
- No maintenance of safety unit, leading to excessive pressure.
- No maintenance on magnesium anode (magnesium anode diameter must be at least 10 mm).
- No cleaning of evaporator or condensate evacuation.
- Modification of the original equipment, without notifying the manufacturer, or use of spare parts not recommended by the manufacturer.

**5.9 DECLARATION OF CONFORMITY.**

If required, the declaration of conformity is available at the manufacturer's premises.

- This device has been designed to serve one Residential Housing Unit only (and similar) subject to assessment of the energy requirement for domestic hot water; it is not a heating system pursuant to the legislation in force.

6 PRODUCT FICHE (IN COMPLIANCE WITH REGULATION 812/2013).

Rapax 100 V2

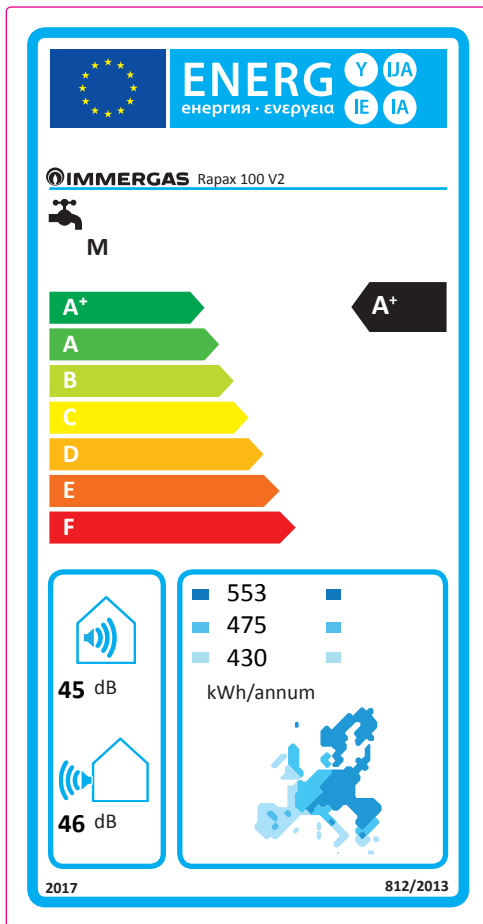

Parameter	value
Energy efficiency in average climate conditions	108 %
Energy efficiency in colder climate conditions	93 %
Energy efficiency in warmer climate conditions	119 %
Annual energy consumption in average climate conditions	475 kW/h
Annual energy consumption in colder climate conditions	553 kW/h
Annual energy consumption in warmer climate conditions	430 kW/h
Thermostat temperature	54 °C
Daily electrical power consumption	2,260 kW/h
V40	127 L

For proper installation of the device, refer to chapter 1 of this booklet (for the installer) and current installation regulations. For proper maintenance, refer to chapter 5 of this booklet (for the maintenance technician) and adhere to the frequencies and methods set out herein.

## 7 PARAMETERS FOR FILLING IN THE PACKAGE FICHE.

Use sheet fig. 7-3 for “assemblies” related to the domestic hot water function (e.g.: water heater + solar thermal system).

Should you wish to install a unit, starting from the Rapax 100 V2 water heater with heat pump, use the package fiche shown in fig. 7-3.

To fill it in correctly, enter the figures shown in table fig. 7-2 (as shown in the package fiche facsimile Fig. 7-1).

The remaining values must be obtained from the technical data sheets of the products used to make up the assembly (e.g. solar devices, integration heat pumps, temperature controllers).

### Facsimile for filling in the domestic hot water production system package fiche.

Water heating energy efficiency of the water heater ①  %

Stated load profile:

---

Solar contribution

From the board of the solar device Auxiliary electricity

( 1,1 x '1' - 10 % ) x 'II' -  - '1' = ② +  %

---

Water heating energy efficiency of the assembly in average climate conditions ③  %

---

Water heating energy efficiency class of the assembly in average climate conditions

	<input type="checkbox"/>	<input type="checkbox"/>	<input type="checkbox"/>	<input type="checkbox"/>	<input type="checkbox"/>	<input type="checkbox"/>	<input type="checkbox"/>	<input type="checkbox"/>	<input type="checkbox"/>	<input type="checkbox"/>
	<b>G</b>	<b>F</b>	<b>E</b>	<b>D</b>	<b>C</b>	<b>B</b>	<b>A</b>	<b>A<sup>+</sup></b>	<b>A<sup>++</sup></b>	<b>A<sup>+++</sup></b>
<input type="checkbox"/> <b>M</b>	< 27 %	≥ 27 %	≥ 30 %	≥ 33 %	≥ 36 %	≥ 39 %	≥ 65 %	≥ 100 %	≥ 130 %	≥ 163 %
<input type="checkbox"/> <b>L</b>	< 27 %	≥ 27 %	≥ 30 %	≥ 34 %	≥ 37 %	≥ 50 %	≥ 75 %	≥ 115 %	≥ 150 %	≥ 188 %
<input type="checkbox"/> <b>XL</b>	< 27 %	≥ 27 %	≥ 30 %	≥ 35 %	≥ 38 %	≥ 55 %	≥ 80 %	≥ 123 %	≥ 160 %	≥ 200 %
<input type="checkbox"/> <b>XXL</b>	< 28 %	≥ 28 %	≥ 32 %	≥ 36 %	≥ 40 %	≥ 60 %	≥ 85 %	≥ 131 %	≥ 170 %	≥ 213 %

Water heating energy efficiency class in colder and hotter climate conditions

Colder: ③  - 0.2 x ②  = ④  %

Hotter: ③  + 0.4 x ②  = ④  %

---

*The energy efficiency of the set of products indicated in this sheet may not reflect the actual energy efficiency after installation since such efficiency is affected by additional factors, such as the heat loss in the distribution system and the size of the products compared to the size and features of the building.*

Fig. 7-1

Parameters for filling in the DHW package fiche.

Parameter	Rapax 100 V2
'I'	108
'II'	*
'III'	*

\* to be determined according to Regulation 812/2013 and transient calculation methods as per Notice of the European Community no. 207/2014.

Fig. 7-2

Domestic hot water production system package fiche.

Water heating energy efficiency of the water heater

%

Stated load profile:

Solar contribution

From the board of the solar device

Auxiliary electricity

( 1.1 x  - 10 % ) x  -  -  =

+  %

Water heating energy efficiency of the assembly in average climate conditions

%

Water heating energy efficiency class of the assembly in average climate conditions

	<input type="checkbox"/>	<input type="checkbox"/>	<input type="checkbox"/>	<input type="checkbox"/>	<input type="checkbox"/>	<input type="checkbox"/>	<input type="checkbox"/>	<input type="checkbox"/>	<input type="checkbox"/>	<input type="checkbox"/>
	<b>G</b>	<b>F</b>	<b>E</b>	<b>D</b>	<b>C</b>	<b>B</b>	<b>A</b>	<b>A<sup>+</sup></b>	<b>A<sup>++</sup></b>	<b>A<sup>+++</sup></b>
<input type="checkbox"/> <b>M</b>	< 27 %	≥ 27 %	≥ 30 %	≥ 33 %	≥ 36 %	≥ 39 %	≥ 65 %	≥ 100 %	≥ 130 %	≥ 163 %
<input type="checkbox"/> <b>L</b>	< 27 %	≥ 27 %	≥ 30 %	≥ 34 %	≥ 37 %	≥ 50 %	≥ 75 %	≥ 115 %	≥ 150 %	≥ 188 %
<input type="checkbox"/> <b>XL</b>	< 27 %	≥ 27 %	≥ 30 %	≥ 35 %	≥ 38 %	≥ 55 %	≥ 80 %	≥ 123 %	≥ 160 %	≥ 200 %
<input type="checkbox"/> <b>XXL</b>	< 28 %	≥ 28 %	≥ 32 %	≥ 36 %	≥ 40 %	≥ 60 %	≥ 85 %	≥ 131 %	≥ 170 %	≥ 213 %

Water heating energy efficiency class in colder and hotter climate conditions

Colder:  - 0.2 x  =  %

Hotter:  + 0.4 x  =  %

The energy efficiency of the set of products indicated in this sheet may not reflect the actual energy efficiency after installation since such efficiency is affected by additional factors, such as the heat loss in the distribution system and the size of the products compared to the size and features of the building.

Fig. 7-3

Follow us

**Immergas Italia**



**immergas.com**

Immergas S.p.A.  
42041 Brescello (RE) - Italy  
Tel. 0522.689011  
Fax 0522.680617

**Certified company ISO 9001**

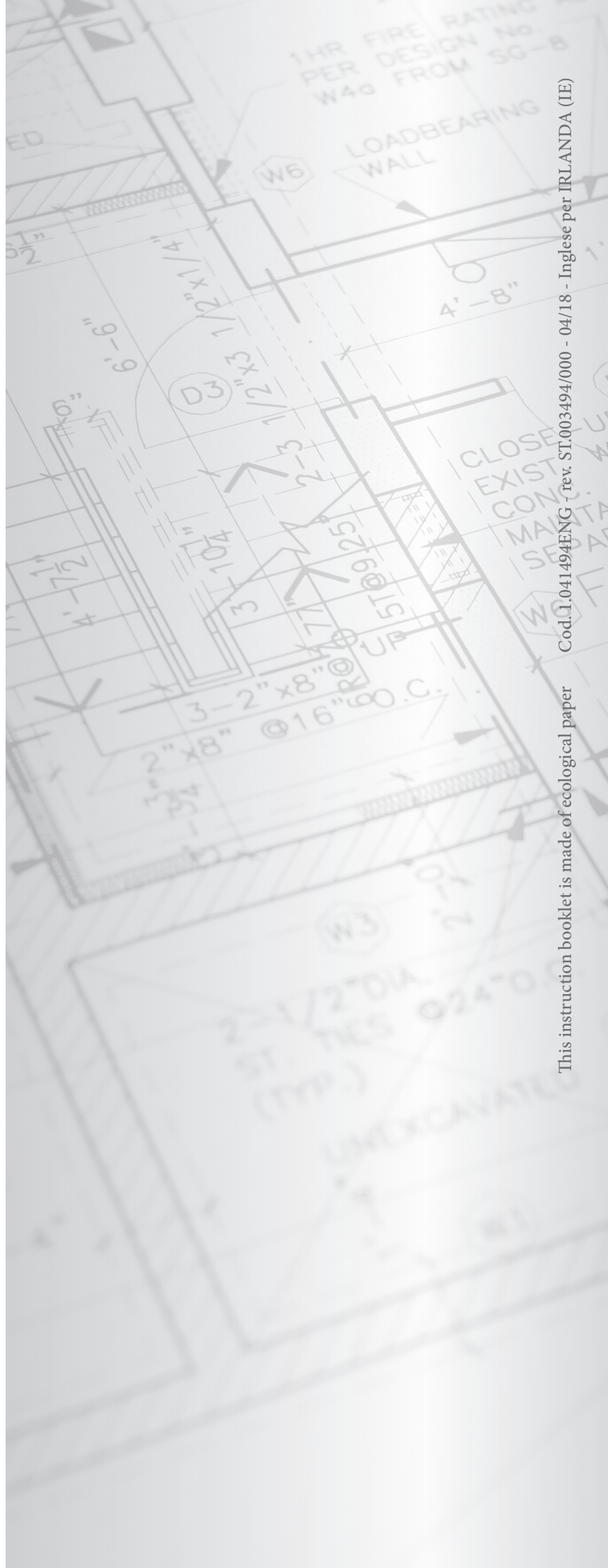

This instruction booklet is made of ecological paper

Cod. I.041494ENG - rev. ST.003494/000 - 04/18 - Inglese per IRLANDA (IE)