

EDX Series

Installation, Operation, Maintenance and Parts Manual

CE Certified 230V-50Hz. [G20(C5), G25(C6), G31(C7)] Infrared Tube Heater.



The EDX Series Infrared Tube Heater is a positive pressure, single-stage radiant heater system. All persons involved with the installation, operation and maintenance of the heater system must read and understand the information in this manual.

⚠ WARNING



Improper installation, adjustment, alteration, service or maintenance can cause property damage, injury or death. Read the installation, operation and maintenance instructions thoroughly before installing or servicing this equipment.

This heater **must** be installed and serviced by a Gas Safe Registered Gas Engineer only! Conversion of the heater for use with other gases must be carried out by a Gas Safe Registered Gas Engineer. Failure to comply could result in personal injury, asphyxiation, death, fire and/or property damage.



In locations used for the storage of combustible materials, signs must be posted to specify the maximum permissible stacking height to maintain the required clearances from the heater to the combustibles. Signs must either be posted adjacent to the heater thermostats or in the absence of such thermostats, in a conspicuous location.

For Your Safety

If you smell gas:

- Do not try to light any appliance.
- Do not touch any electrical switch.
- Do not use any phone in your building.
- Immediately call your gas supplier from a neighbor's phone.
- Follow the gas supplier's instructions.
- If you cannot reach your gas supplier, call the fire department.



Keep these instructions for future reference.

© 2012 Detroit Radiant Products Co.
LIOEDXc-Rev. 15112
Print: 1M-6/12(CDS)
Replaces: LIOEDXc-8/11(DRP)

Contents

1.0	INTRODUCTION	3
1.1	Overview	3
1.2	EDX Series Technical Specifications	3
2.0	SAFETY	4
2.1	Warning Symbols	4
2.2	Applications	4
2.3	Codes and Regulations	5
2.4	Clearance to Combustibles	6
3.0	INSTALLATION	8
3.1	Design Considerations and Prechecks	8
3.2	Recommended Mounting Heights	10
3.3	Hanger Placement and Suspension	11
3.4	Optional U-Bend or Elbow Accessory Configuration	14
3.5	Radiant Tube Assembly	15
3.6	Burner Control Box Suspension	18
3.7	Reflector Assembly	19
3.8	Baffle Assembly and Placement	21
3.9	Venting	23
3.10	Combustion Air Requirements	28
3.11	Gas Supply	30
3.12	Electrical Requirements	33
4.0	OPERATION	35
5.0	MAINTENANCE	36
5.1	Troubleshooting Guide	37
5.2	Burner Assembly Components	38
5.3	Tube and Reflector Components	39
6.0	KIT CONTENTS	40

AVAILABLE MODELS

Model	Input MBH	Input Kw	Consumption M ³			Length		Kit	Combustion Chamber	Radiant Tubes
			G20	G25	G31	Ft	M			
EDX-20-50	50,000	14.7	1.38	1.73	0.56	21'-8"	6.6	20KIT	Aluminized	Aluminized or HRT
EDX-20-75	75,000	22.0	2.07	2.59	0.83	21'-8"	6.6	20KIT	Aluminized	Aluminized or HRT
EDX-30-50	50,000	14.7	1.38	1.73	0.56	31'-4"	9.5	30KIT	Aluminized	Aluminized or HRT
EDX-30-75	75,000	22.0	2.07	2.59	0.83	31'-4"	9.5	30KIT	Aluminized	Aluminized or HRT
EDX-30-100	100,000	29.3	2.76	3.46	1.11	31'-4"	9.5	30KIT	Aluminized	Aluminized or HRT
EDX-40-50	50,000	14.7	1.38	1.73	0.56	41'-0"	12.5	40KIT	Aluminized	Aluminized or HRT
EDX-40-75	75,000	22.0	2.07	2.59	0.83	41'-0"	12.5	40KIT	Aluminized	Aluminized or HRT
EDX-40-100	100,000	29.3	2.76	3.46	1.11	41'-0"	12.5	40KIT	Aluminized	Aluminized or HRT
EDX-40-125	125,000	36.7	3.44	4.32	1.38	41'-0"	12.5	40KIT	Aluminized	Aluminized or HRT
EDX-40-150	147,000	43.0	4.14	5.19	1.66	41'-0"	12.5	40KIT	Titan-Alum	Aluminized or HRT
EDX-50-100	100,000	29.3	2.76	3.46	1.11	50'-8"	15.4	50KIT	Aluminized	Aluminized or HRT
EDX-50-125	125,000	36.7	3.44	4.32	1.38	50'-8"	15.4	50KIT	Aluminized	Aluminized or HRT
EDX-50-150	147,000	43.0	4.14	5.19	1.66	50'-8"	15.4	50KIT	Titan-Alum	Aluminized or HRT
EDX-50-170 [†]	170,000	50.0	4.71	5.90	1.89	50'-8"	15.4	50KIT	Titan-Alum	Aluminized or HRT
EDX-50-187 [†]	187,000	55.0	5.18	6.49	2.08	50'-8"	15.4	50KIT	Titan-Alum	Aluminized or HRT
EDX-50-204 [†]	204,000	60.0	5.65	7.08	2.27	50'-8"	15.4	50KIT	Titan-Alum	Aluminized or HRT
EDX-60-125	125,000	36.7	3.44	4.32	1.38	60'-4"	18.4	60KIT	Aluminized	Aluminized or HRT
EDX-60-150	147,000	43.0	4.14	5.19	1.66	60'-4"	18.4	60KIT	Titan-Alum	Aluminized or HRT
EDX-60-170 [†]	170,000	50.0	4.71	5.90	1.89	60'-4"	18.4	60KIT	Titan-Alum	Aluminized or HRT
EDX-60-187 [†]	187,000	55.0	5.18	6.49	2.08	60'-4"	18.4	60KIT	Titan-Alum	Aluminized or HRT
EDX-60-204 [†]	204,000	60.0	5.65	7.08	2.27	60'-4"	18.4	60KIT	Titan-Alum	Aluminized or HRT
EDX-70-170 [†]	170,000	50.0	4.71	5.90	1.89	70'-0"	21.3	70KIT	Titan-Alum	Aluminized or HRT
EDX-70-187 [†]	187,000	55.0	5.18	6.49	2.08	70.00	21	70KIT	Titan-Alum	Aluminized or HRT
EDX-70-204 [†]	204,000	60.0	5.65	7.08	2.27	70.00	21	70KIT	Titan-Alum	Aluminized or HRT

[†] These models are not CE certified for (G31) Propane gas.

1.0 Introduction

1.1 Overview

The intent of this manual is to provide information regarding general safety, installation, operation and maintenance of this tube heater. You must read and understand all instructions and safety warnings before installing or servicing the tube heater.

1.2 EDX Series Technical Specifications

Model*	Gas Type	Heat input (kW)	Injector Size (mm)	Injector Markings (DMS)	Air Inlet Orifice (mm)	Air Inlet Marking	Gas Connection Size (mm)	Minimum Inlet Gas Pressure (mbar)	Normal Inlet Gas Pressure (mbar)	Burner Operating Pressure (mbar)	Flue Dia. (mm)	Air Proving SetPoint (Pa)
EDX 50	I2H (20)	14.7	3.26	30	36.5	1 7/16	Rp1/2 (DN15)	11.5	20.0	9.0	100	25
	I2L (25)		3.26	30	36.5	1 7/16		15.5	25.0	13.0		
	I3P (31)		2.08	45	38.1	1 1/2		27.5	37.0	25.0		
EDX 75	I2H (20)	22.0	4.22	19	39.7	1 9/16	Rp1/2 (DN15)	11.5	20.0	9.0	100	25
	I2L (25)		4.22	19	39.7	1 9/16		15.5	25.0	13.0		
	I3P (31)		2.64	37	41.3	1 5/8		27.5	37.0	25.0		
EDX 100	I2H (20)	29.3	4.85	11	41.3	1 5/8	Rp1/2 (DN15)	11.5	20.0	9.0	100	35
	I2L (25)		4.85	11	41.3	1 5/8		15.5	25.0	13.0		
	I3P (31)		2.95	32	47.6	1 7/8		27.5	37.0	25.0		
EDX 125	I2H (20)	36.7	5.22	5	46.0	1 13/16	Rp1/2 (DN15)	12.5	20.0	10.0	100	35
	I2L (25)		5.22	5	46.0	1 13/16		17.5	25.0	15.0		
	I3P (31)		3.26	30	50.8	2		27.5	37.0	25.0		
EDX 150	I2H (20)	43.0	5.41	3	47.6	1 7/8	Rp1/2 (DN15)	12.5	20.0	10.0	100	50
	I2L (25)		5.41	3	47.6	1 7/8		17.5	25.0	15.0		
	I3P (31)		3.66	27	54.0	2 1/8		27.5	37.0	25.0		
EDX 170	I2H (20)	50.0	6.14	C	50.8	2	Rp1/2 (DN15)	11.5	20.0	9.0	100	50
	I2L (25)		6.14	C	50.8	2		15.5	25.0	13.0		
	I3P (31)		N/A	N/A	N/A	N/A		N/A	N/A	N/A		
EDX 188	I2H (20)	55.0	6.52	F	57.2	2 1/4	Rp1/2 (DN15)	11.5	20.0	9.0	100	50
	I2L (25)		6.52	F	57.2	2 1/4		15.5	25.0	13.0		
	I3P (31)		N/A	N/A	N/A	N/A		N/A	N/A	N/A		
EDX 204	I2H (20)	60.0	7.03	J	60.3	2 3/8	Rp1/2 (DN15)	11.5	20.0	9.0	100	50
	I2L (25)		7.03	J	60.3	2 3/8		15.5	25.0	13.2		
	I3P (31)		N/A	N/A	N/A	N/A		N/A	N/A	N/A		

* Consult factory for technical specifications on all other models.

IMPORTANT: Reference box label for baffle lengths.

2.0 Safety

The intent of this manual is to provide information regarding general safety, installation, operation and maintenance of this tube heater. You must read and understand all instructions and safety warnings before installing or servicing the tube heater.

⚠ WARNING



Improper installation, adjustment, alteration, service or maintenance can cause property damage, serious injury or death. Read and understand, the installation, operating and maintenance instructions thoroughly before installing or servicing this equipment. Only trained, qualified gas installation and service personnel may install or service this equipment.

2.1 Warning Symbols

Safety is the most important consideration during installation, operation and maintenance of the tube heater. You will see the following symbols and signal words when there is a hazard related to safety or property damage.

⚠ WARNING

Warning indicates a potentially hazardous situation which, if not avoided, could result in death or injury.

⚠ CAUTION

Caution indicates a potentially hazardous situation which, if not avoided, could result in minor or moderate injury.

NOTICE

Notice indicates a potentially hazardous situation which, if not avoided, could result in property damage.

2.2 Applications

This is not an explosion-proof heater. No EDX Series heater may be used in a Class 1 or Class 2 Explosive environment. Consult the local Fire Marshall, fire insurance carrier and other authorities for approval if the proposed installation is in question.

Commercial and Industrial

This tube heater is designed and certified for use in industrial and commercial buildings such as, warehouses, manufacturing plants, aircraft hangars and vehicle maintenance shops.

⚠ WARNING



Not for residential use!

Do not use this heater in the home, sleeping quarters, attached garages, etc.

2.3 Codes and Regulations

The following must be reviewed before installing this heater:

- Check the heater rating label on the heater to verify the proper gas to be used. Check other labels on the heater to verify proper mounting and clearance to combustibles.
- Signs must be posted in storage areas to specify maximum stacking heights allowed in order to maintain published clearances to combustibles.
- Notwithstanding their limited scope, this appliance must be installed in accordance with relevant provisions of the following regulations:

GB - United Kingdom:

Gas Safety (Installation and Use) Regulations 1998 and BS6891:1998. Due account should be taken of any obligations arising from the Health and Safety at Work etc. Act 1974, the current Building Regulations, the current I.E.E. Regulations and other relevant codes of practice.

IE - Ireland:

I.S.3212:1987, ICP 4, I.S.327. Due account should be taken of any obligations arising for the current Building Regulations, the current I.E.E. Regulations and other relevant codes of practice.

- Under no circumstance is either the gas supply line or the electrical supply line to the heater to provide any assistance in the suspension of the heater.
- The weight of the heater must be entirely suspended from a permanent part of the building structure having adequate load characteristics.
- Neither the gas supply line, electrical supply line or sprinkler heads shall be located within the minimum published clearance to combustibles as shown on page 7.

2.4 Clearance to Combustibles

⚠ WARNING



This is not an explosion-proof heater. Do not store or use flammable objects, liquids or vapor in the vicinity of the heater. Where there is the possibility of exposure to flammable vapors or highly combustible materials, consult the local fire marshal, fire insurance carrier and other authorities for approval of the proposed installation.

⚠ WARNING



This heater should be installed so that the minimum clearances to combustibles, as marked on the heater, will be maintained from vehicles parked below. If vehicle lifts are present, ensure that these clearances will be maintained from the highest raised vehicle.

⚠ WARNING



Fire Hazard. Always maintain published clearance to combustibles. Failure to comply with the stated clearances to combustibles could result in personal injury, death and/or property damage.

Hazards

For maximum safety, the building must be evaluated for hazards before installing this heating system. A critical safety factor before installation is the clearance to combustibles.

Clearances to combustibles is defined as the minimum distance that **must** be maintained between the tube surface or reflector and combustible materials. It also pertains to the distance that must be maintained from moving objects (e.g. overhead doors, cranes, vehicle lifts, etc.) around the tube heater.

The following is a partial list of items to maintain clearances from:

- Gas and electrical lines
- Combustible and explosive materials
- Chemical storage areas
- Areas of high chemical fume concentrations
- Vehicle parking areas
- Vehicle lifts
- Hoists or cranes
- Storage areas with stacked materials
- Lighting
- Sprinkler heads
- Overhead doors and tracks
- Dirty, contaminated areas

If you are unsure about the proposed installation, consult your local fire Marshall fire insurance carrier or other qualified authorities for the approval of the proposed installation.

Safety Signs and Labels

It is important to provide warnings to alert individuals to potential hazards and safety actions. Local codes may require you to post a sign “specifying the maximum permissible stacking height to maintain the required published clearances from the heater to combustibles” near the heater’s thermostat or, in the absence of such thermostats, in a conspicuous location.

All safety labels must be maintained on this appliance. Contact your distributor if replacement labels are needed.

Clearance to Combustibles

IMPORTANT:

For the safe installation of this unit, the clearance to combustibles data below contains clearances that **must** be maintained.

Check the rating plate on the heater to verify the minimum clearance to combustibles and gas type for your model heater.

EDX Series Clearance to Combustibles Data (mm)

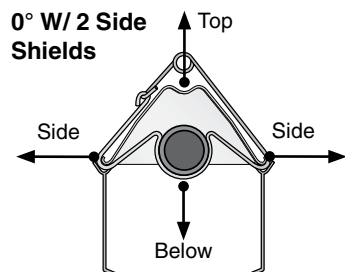
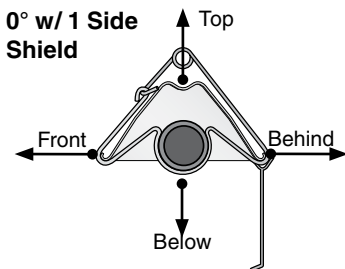
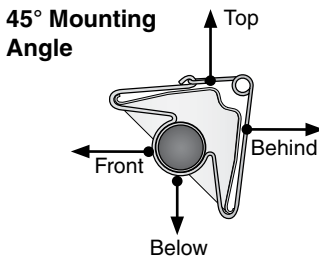
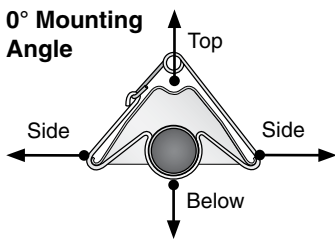

Model No.	Mounting Angle*	Side		Top	Below	
		Front	Behind			
EDX 50, 60 (14.7, 17.6 kW)	0°	229	229	152	1194	
	45°	991	203	254	1194	
	w/ 1 side shield	0°	737	203	152	1194
	w/ 2 side shields	0°	229	229	152	1194
6.1m downstream of burner	0°	178	178	152	762	
EDX 75 (22.0 kW)	0°	229	229	152	1524	
	45°	991	203	254	1524	
	w/ 1 side shield	0°	737	203	152	1524
	w/ 2 side shields	0°	229	229	152	1524
6.1m downstream of burner	0°	178	178	152	762	
EDX 100 (29.3 kW)	0°	356	356	152	1676	
	45°	991	203	254	1676	
	w/ 1 side shield	0°	737	203	152	1676
	w/ 2 side shields	0°	406	406	152	1676
6.1m downstream of burner	0°	178	178	152	762	
EDX 125 (36.7 kW)	0°	508	508	152	1930	
	45°	1473	203	254	1930	
	w/ 1 side shield	0°	1067	203	152	1930
	w/ 2 side shields	0°	508	508	152	1930
6.1m downstream of burner	0°	178	178	152	762	
EDX 150 (43.0 kW)	0°	610	610	152	2057	
	45°	1473	203	254	2057	
	w/ 1 side shield	0°	1067	203	152	2057
	w/ 2 side shields	0°	584	584	152	2057
6.1m downstream of burner	0°	279	279	152	1118	
EDX 170 (50.0 kW)	0°	864	864	152	2337	
	45°	1600	203	254	2337	
	w/ 1 side shield	0°	1270	203	152	2337
	w/ 2 side shields	0°	762	762	152	2337
6.1m downstream of burner	0°	279	279	152	1118	
EDX 188, 204 (55.0, 60.0 kW)	0°	1041	1041	152	2388	
	45°	1600	203	254	2388	
	w/ 1 side shield	0°	1372	203	152	2388
	w/ 2 side shields	0°	762	762	152	2388
6.1m downstream of burner	0°	279	279	152	1118	

* Heaters mounted on an angle between 0° to 45° must maintain clearances posted for 0° or 45° mounting angles; whichever is greater.



3.0 Installation

3.1 Design Considerations and Prechecks

Placement of infrared tube heaters is influenced by many factors. Aside from safety factors, considerations such as the number of elbows that are allowed, maximum vent lengths, ducting of combustion air and combining vents are a few examples. This manual, along with national, state and local codes, addresses these issues. It is critical that all guidelines and instructions are followed.

To ensure a properly designed heating system, a heating layout should be developed for the correct placement of the burner control box, radiant tubing, venting and combustion air intake ducts. Inspect and evaluate the mounting conditions, vent locations, gas supply and electrical wiring. Refer to the chart below for the recommended distances for the model being installed.

EDX SERIES HEATER INSTALLATION CHART (mm)

Model No.	Recommended Mounting Heights	Distance Between Heaters	Distance Between Heater Rows	Maximum Distance Between Heater and Wall
EDX 50, 60 (14.7, 17.6 kw)	3050 - 4880	3050 - 9140	3660 - 19810	5030
EDX 75 (22.0 kw)	3050 - 5490	6100 - 9150	9150 - 15240	5180
EDX 100 (29.3 kw)	3355 - 6100	6100 - 9150	9150 - 15240	6100
EDX 125 (36.7 kw)	3965 - 8230	6100 - 9150	9150 - 15240	6100
EDX 150 (43.0 kw)	4270 - 9150	9150 - 12200	12200 - 18290	6100
EDX 170 (50.0 kW)	4575 - 12800	9150 - 12200	12200 - 18290	9145
EDX 188 (55.0 kW)	4875 - 12800	9150 - 12200	12200 - 18290	9145
EDX 204 (60.0 kW)	5180 - 12800	9150 - 12200	12200 - 18290	9145

NOTE: This chart is provided as a guideline. Actual conditions may dictate variation from this data.

When designing an infrared radiant heating system, consider the following:

- Has the building's heat loss been evaluated?
- Does the design meet the needs of the space?
- Have all clearance to combustible situations been observed?
- Have recommended mounting heights been observed?
- Is the supply (burner) end of the heater located where more heat is required?
- Is it best to offset the heaters and/or rotate the reflectors towards the heat zone?
- Are protective guards, side shields, 'U' or 'L' reflector covers needed?
- Does the heater require outside fresh air for combustion?
- Is the environment harsh or contaminated (requiring outside air for combustion)?
- Are chemicals or vapor a concern (requiring outside air for combustion)?

NOTE: The effective infrared surface temperature of a person or object may be diminished with wind above 8 km/h. The use of adequate wind barrier(s) may be required.

NOTE: When heated, materials high in hydrocarbons (solvents, paint thinner, mineral spirits, formaldehydes, etc.) can evaporate. This may result in odors or fumes being emitted into the environment. To correct this problem, clean the area and/or introduce additional ventilation.

Heaters installed and serviced in accordance with the installation manual do not emit odors into the environment. See notice on page 28 for additional information.

Design Scenario

A tube heater system is being installed in 27.4m (L) x 15.2m (W) space with 4.3m ceilings. Two overhead doors are located at one end and an equipment storage area exists on one side. The calculated heat load is 85 kW.

Figure 3.1 - Poor Design

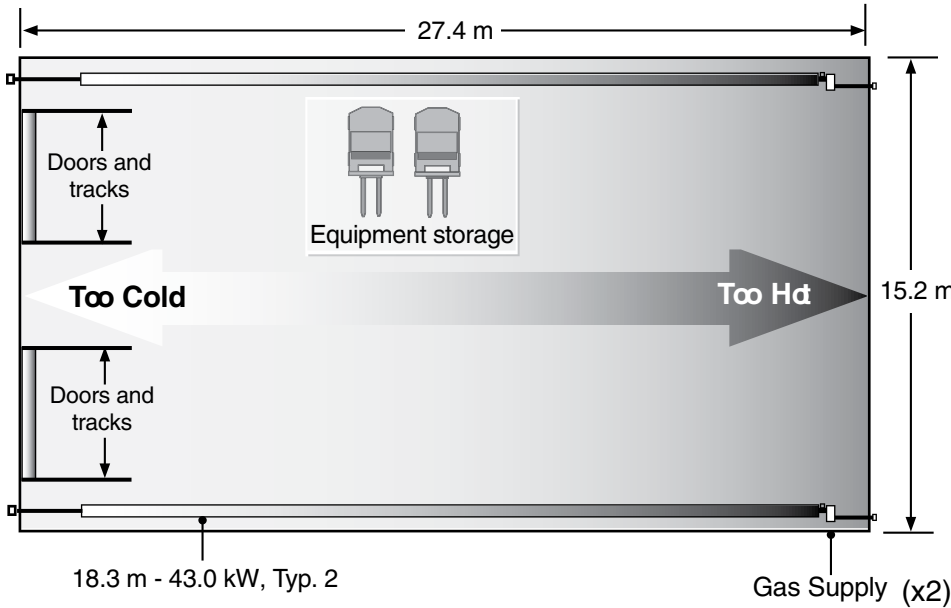

- Two burners (43.0 kW each) are placed at one end, opposite the area of highest demand (overhead doors).
- Recommended mounting heights are not observed.
- Produces an uneven heat distribution.

Figure 3.2 - Good Design

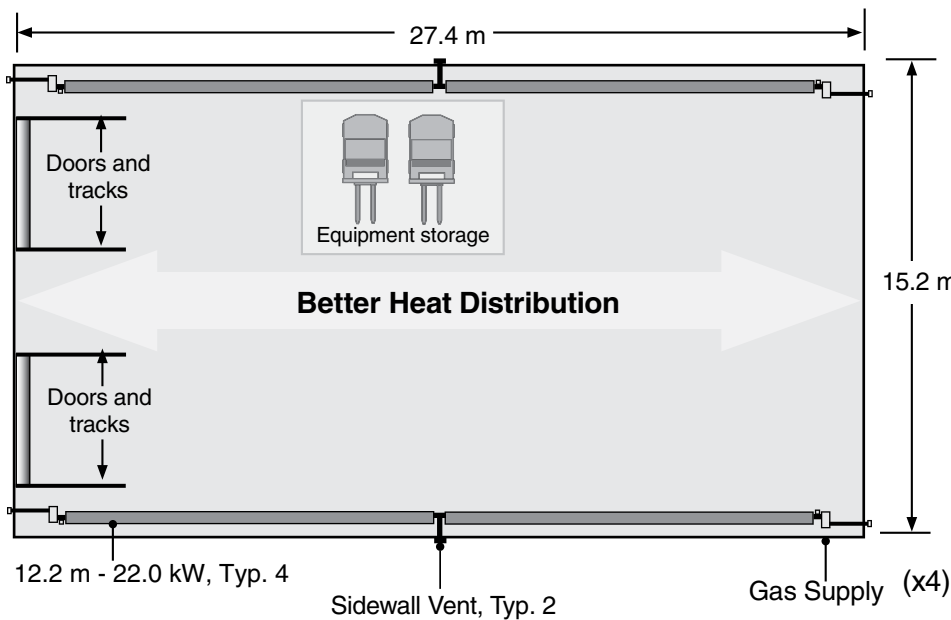

- Four burners (22 kW each) are placed in each corner. Burner (hotter) ends direct heat to areas of highest heat demand.
- Recommended mounting heights observed.
- Distributes heat more evenly.

Design Criteria

3.2 Recommended Mounting Heights

Model Length	kW Range	BTU Range	Recommended Mounting Heights (M)	Coverage Straight Config. (LxW) (M)	Coverage U-Tube Config. (LxW)	Distance Between Heater Rows (M) Dim. A	Distance Between Heater Rows (M) Dim. B	Max. Distance Between Heaters and Wall (M) Dim. C
EDX 6.6M	14.7 - 17.6	50-60 MBH	3.5 - 5.0	6.5 x 4.0	4.0 x 4.0	3.5 - 6.5	6.5 - 12.5	5.0
	22.0 - 29.3	75 MBH	4.0 - 6.5	7.0 x 4.5	4.0 x 4.5	6.5 - 9.5	9.5 - 15.5	5.5
EDX 9.6M	14.7 - 17.6	50-60 MBH	3.5 - 5.0	9.5 x 4.5	5.5 x 4.0	3.5 - 6.5	6.5 - 12.5	5.5
	22.0 - 36.7	75-125 MBH	4.0 - 6.5	10.0 x 5.5	5.5 x 4.5	6.5 - 9.5	9.5 - 15.5	6.5
	29.3 - 36.7	100 MBH	3.5 - 6.5	10.0 x 5.5	5.5 x 4.5	6.5 - 9.5	9.5 - 15.5	6.5
EHL 12.5M	22.0 - 36.7	75-125 MBH	4.0 - 7.0	13.5 x 6.5	7.0 x 5.5	6.5 - 9.5	9.5 - 15.5	6.5
	43.0	147 MBH	5.0 - 9.5	14.0 x 8.0	7.5 x 6.5	9.5 - 12.5	12.5 - 18.5	8.0
EDX 15.4M	14.7 - 17.6	50-60 MBH	3.5 - 5.0	12.5 x 5.5	7.0 x 4.5	3.5 - 6.5	6.5 - 12.5	6.5
	22.0 - 36.7	75-125 MBH	4.0 - 6.5	13.5 x 6.5	7.0 x 5.5	6.5 - 9.5	9.5 - 15.5	6.5
	43.0	147-204 MBH	5.0 - 9.5	14.0 x 8.0	7.5 x 6.5	9.5 - 12.5	12.5 - 18.5	8.0
EDX 18.4M	36.7	125 MBH	5.0 - 8.0	20.5 x 8.5	10.0 x 6.5	6.5 - 9.5	9.5 - 15.5	8.0
	43.0	147-204 MBH	5.5 - 12.5	20.5 x 10.5	10.5 x 8.0	9.5 - 12.5	12.5 - 18.5	8.0
EHL 21.3M	50.0-60.0	170-204 MBH	5.5 - 13.5	24.0 x 11.5	12.0 x 9.0	9.5 - 12.5	12.5 - 18.5	9.0

NOTE: Factory recommended mounting heights are listed as a guideline. If infrared heaters are mounted too low or too high, they may result in heat discomfort or lack of heat. It is generally recommended to observe the recommended mounting heights to optimize comfort conditions. However, certain applications such as spot heating, freeze protection, outdoor patio heating or very high ceilings may result in the heaters being mounted outside of the factory recommended mounting heights. Clearances to combustibles must always be maintained.

Figure 3.3 • Recommended Mounting Heights and Distances - see chart above for dimensions.

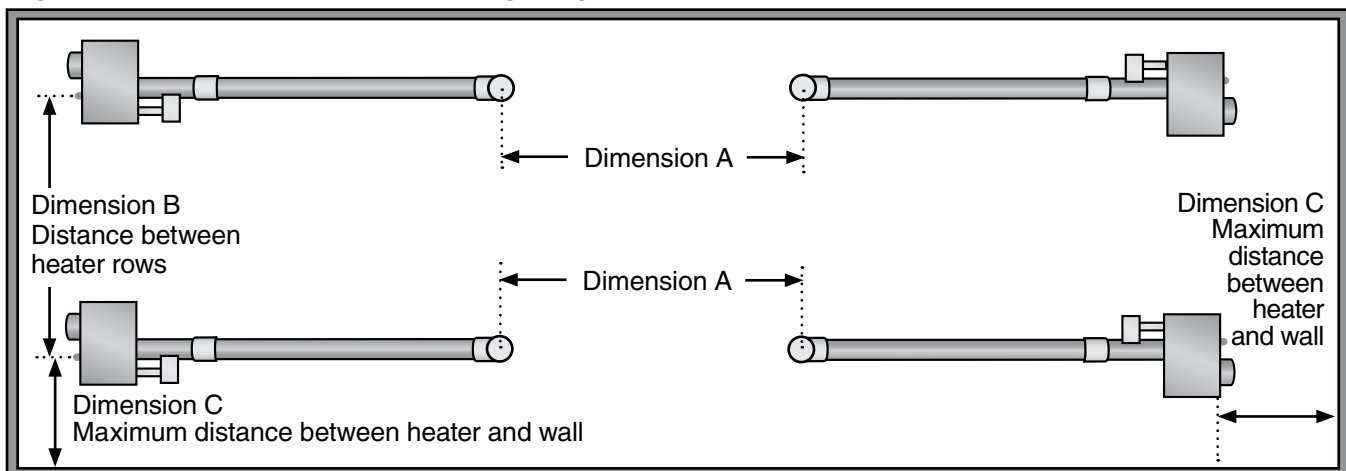

3.3 Hanger Placement and Suspension

⚠ WARNING



Improper suspension of the heater may result in collapse and being crushed. Always suspend the appliance from a permanent part of the building structure that can support the total weight and force of the heater.

⚠ WARNING



Failure to maintain the published clearance to combustibles may result in fire and/or explosion, property damage, serious injury or death. Always maintain clearances and post signs where needed.

Suspension of the heater must conform to applicable codes referenced in the Safety section and these instructions.

❶ Lay radiant tubing out in the following order. Position tubes in their approximate locations. Figure 3.4.

- Primary combustion chamber.
- Radiant emitter tubes.

IMPORTANT! EDX-150, -177, -187 and -204 (43.0-60.0 kW) models must use the titanium alloy treated combustion chamber as the first tube connected to the burner control box. The combustion chamber has an orange identification sticker located on the swaged end of the tube.

❷ Mark locations for hanging points. Figure 3.4.

NOTE: If the available hanging points do not allow for the recommended spacing (or if an alternative hanging method is utilized) then additional hangers may be necessary.

- The spacing between the burner control box mounting brackets and the first hanger should be approximately 711mm.
- The space between the first two hangers placed on the first tube should be approximately 2692mm.
- The space between hangers thereafter, one per tube, should be approximately 2946mm.

Hanger Placement and Suspension

Figure 3.4 • Heater Suspension Layout

NOTE:

A sticker identifying the combustion chamber(s) is located on the swaged end of the tube(s).

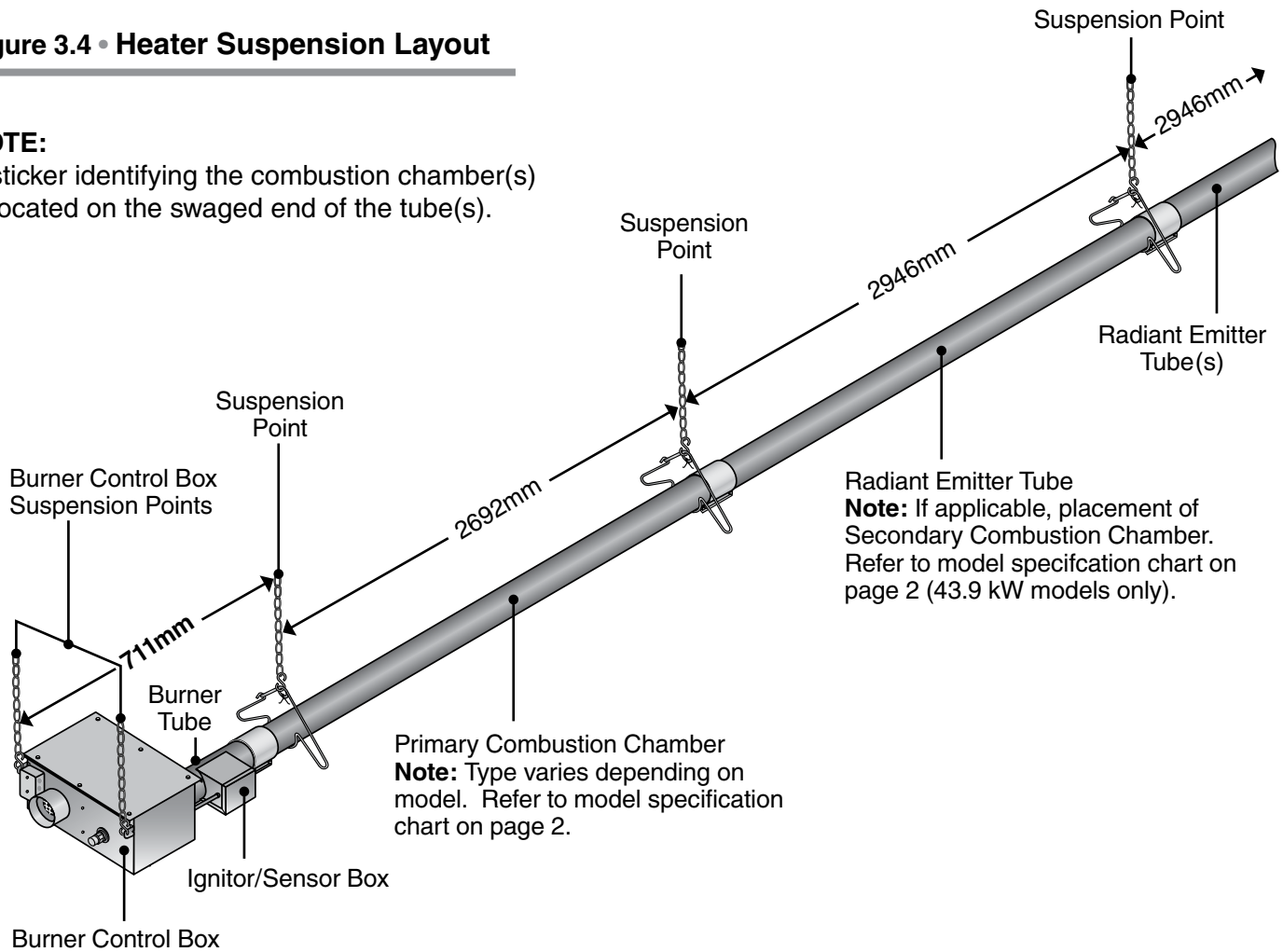

Heater Mounting Requirements and Weights

Model Length	Dimension Straight Config. (mm)	Suspension Points	Control Box Stabilizer	Shipping Weight (kg)	Stainless Steel Ship Weight (kg)	Chain Set Qty. Straight Config.	Chain Set Qty. U-Tube Config.	Optional Brass Knuckles (P/N: BK)	Optional Single Mount Bracket (P/N: SMB) U Config. Only.
6.6M	6604	3	2	54.5	N/A	5	6	3	2
9.6M	9550	4	2	73.0	88.5	6	7	4	N/A
12.5M	12497	5	2	86.5	107.0	7	8	5	3
15.4M	15443	6	2	107.0	132.0	8	9	6	N/A
18.4M	18390	7	2	102.5	150.0	9	10	7	4
21.3M	21336	8	2	136.0	N/A	10	11	8	N/A

Hanger Placement and Suspension

Suspension of the heater must conform to applicable codes referenced in the Safety section and these instructions.

- ③ Prepare the mounting surface, if necessary, such as: weld blocks, drill holes. Figure 3.5.
Note: The burner control box and radiant tubes should be in straight alignment and level.
- ④ Fasten beam clamp, screw hook or other type of suspension anchor to hanging point.
- ⑤ Attach and close S-hook and #1 double-loop chain to anchor. Check that it is securely attached.
NOTE: Threaded rod and turnbuckles may be used.
- ⑥ Attach hangers to chains. Adjust chain lengths until radiant tubing is level and equal weight distribution is achieved. **NOTE:** Chains must be straight up and down. Do not install chains at an angle as this can result in tube warpage or separation.

Figure 3.5 • Mounting the Hangers

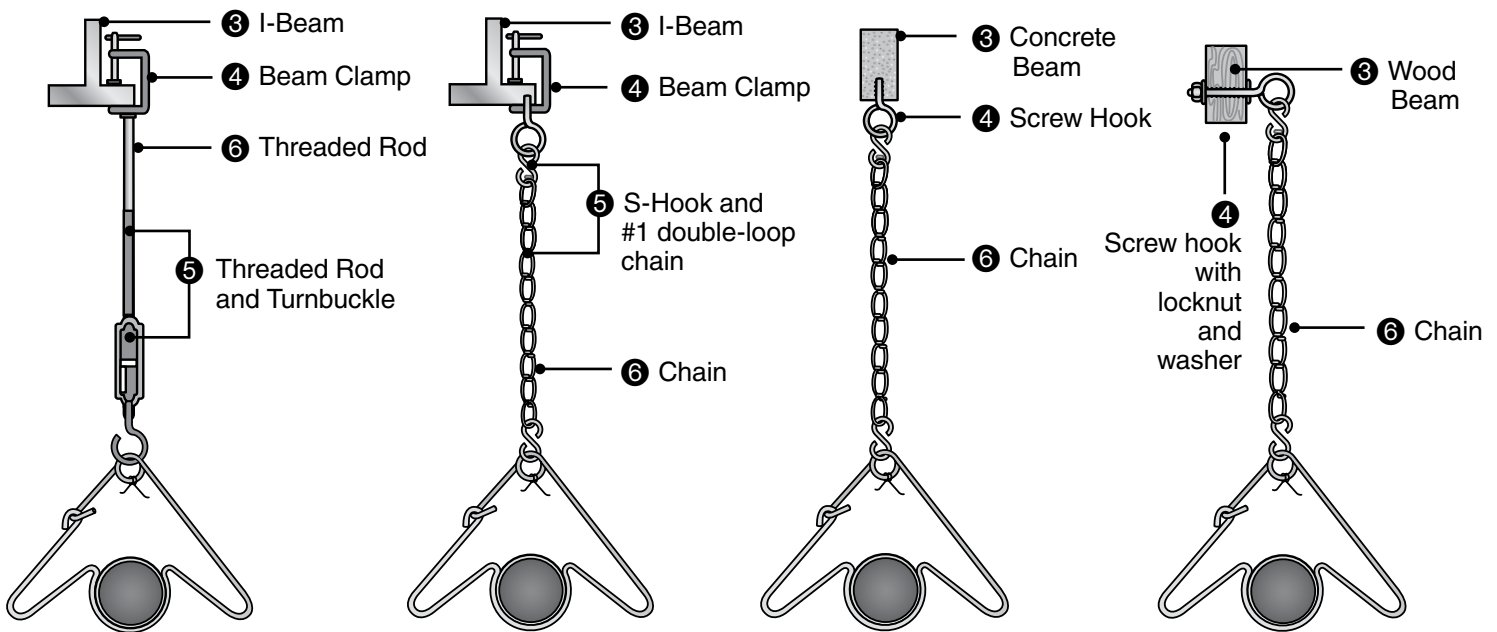

3.4 Optional U-Bend or Elbow Accessory Configuration

Figure 3.6 • U-Tube Hanger Mounting Options

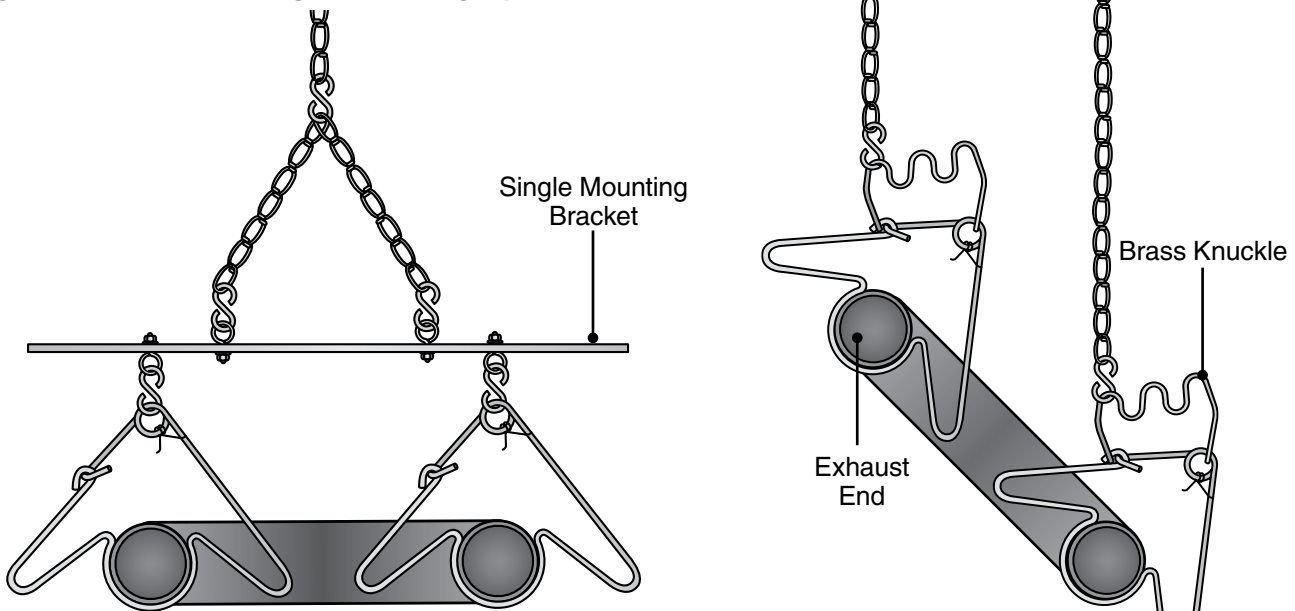

U-Tubes can be mounted from a single suspension point using a Single Mounting Bracket (P/N: SMB) with five S-hooks and #1 double-loop chains.

U-Tubes can be mounted at a 15, 30 or 45 degree angle with two suspension points, using two Brass Knuckle (P/N: BK) fittings, #1 double-loop chains and S-hooks.

Figure 3.7 • Angled Hanger Mounting Options

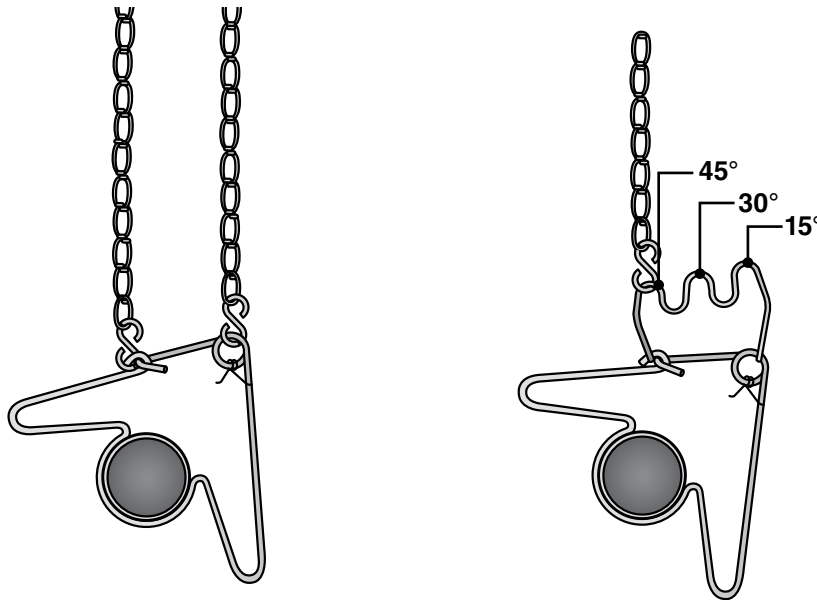

For 45 degree hanging angle use two S-hooks and two #1 double-loop chains.

For variety of hanging angles, use the Brass Knuckle (P/N: BK) fitting with a #1 double-loop chain and S-hook.

3.5 Radiant Tube Assembly

To install the radiant tubes:

- 1 Place tubes in hangers with the welded seam facing downward and the swaged end of the tube towards the exhaust end of the heater system (see Figure 3.8).

Refer to section 3.8 on page 21 for tube installation sequence.

Figure 3.8 • Attach Hangers

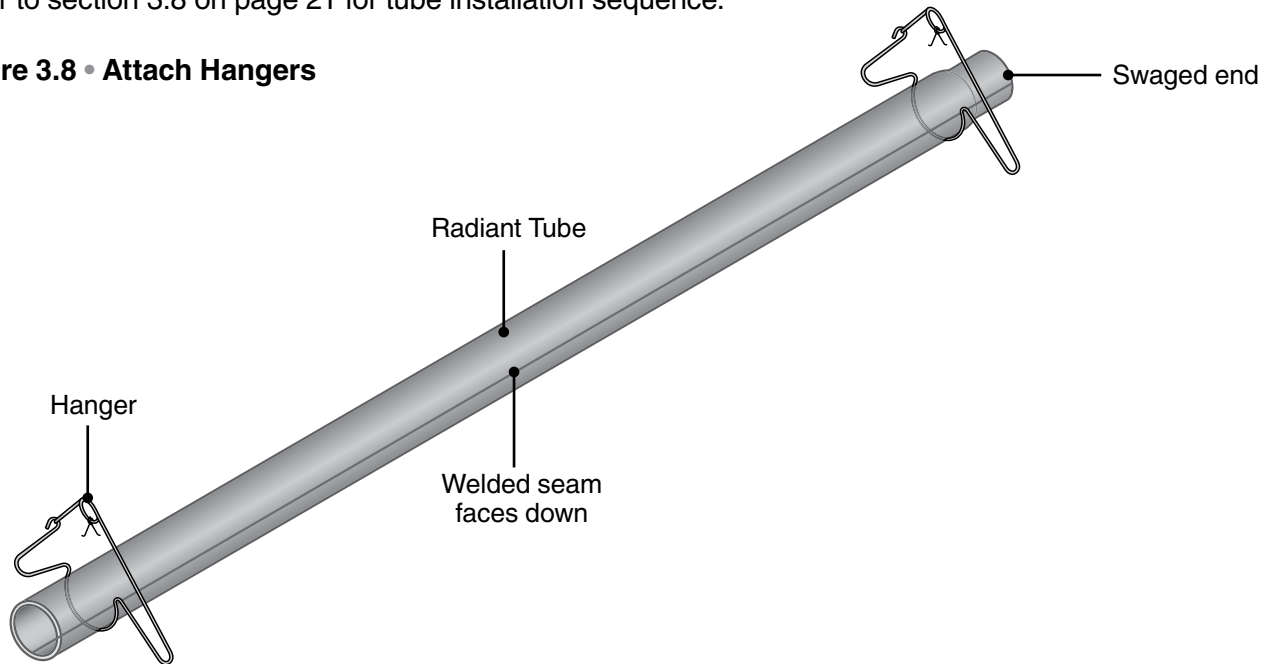

- 2 Slide tube clamps onto radiant tubes (see Figure 3.9).

Figure 3.9 • Attach Tube Clamps

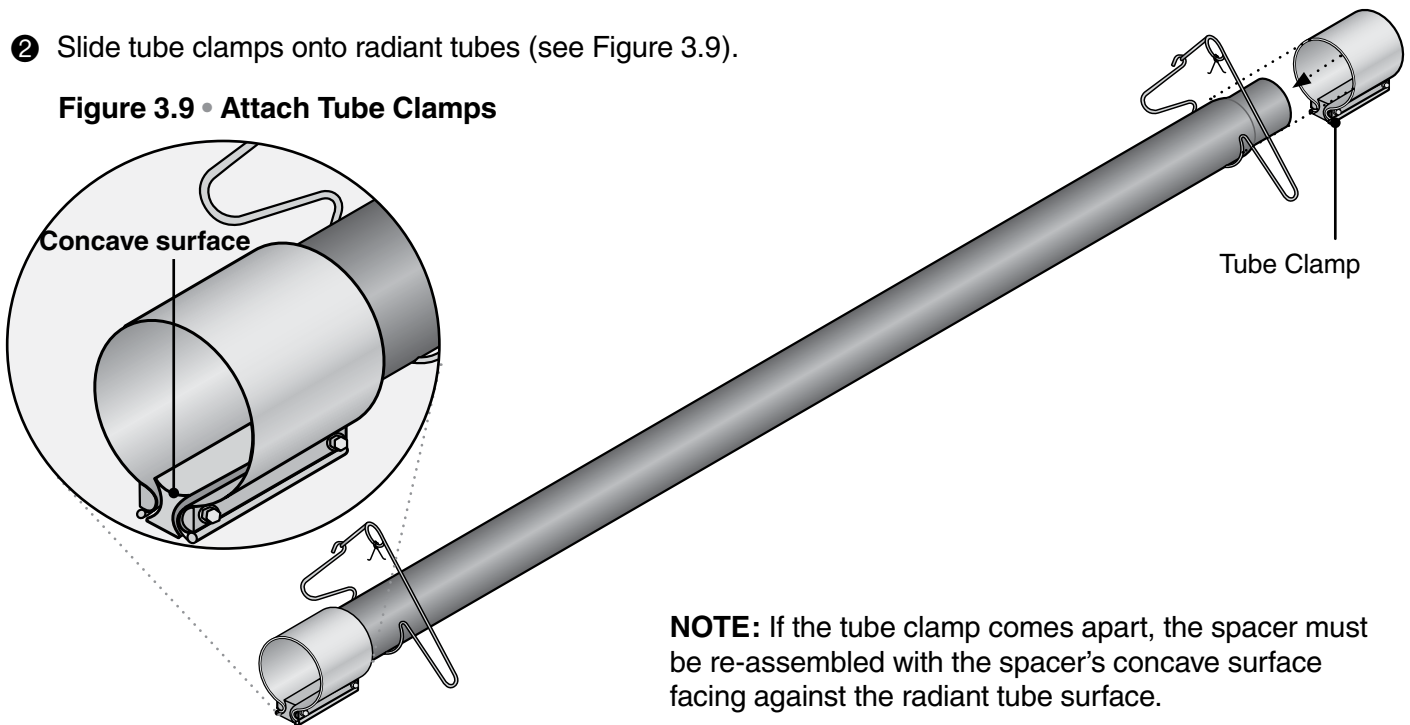

Radiant Tube Assembly

- ③ Slip-fit the radiant tube sections together until tightly connected (install swaged end of each tube towards exhaust end). Note: If it is difficult to mate the tubes, they may be installed incorrectly.
- ④ Center tube clamps over the seams where two radiant tube sections connect. If necessary, rotate tube clamps so they will not interfere with the reflector end caps during expansion and contraction of the heater while operating.
- ⑤ Tighten tube clamp bolts to secure. When proper compression is obtained (30-44 Nm), the tube seam will create a visible mark on the tube clamp. **NOTE:** Excessive torque may damage the tube clamp.
- ⑥ Determine the location of the burner control box and note the placement of the mounting chains.

Figure 3.10 • Tube Connections

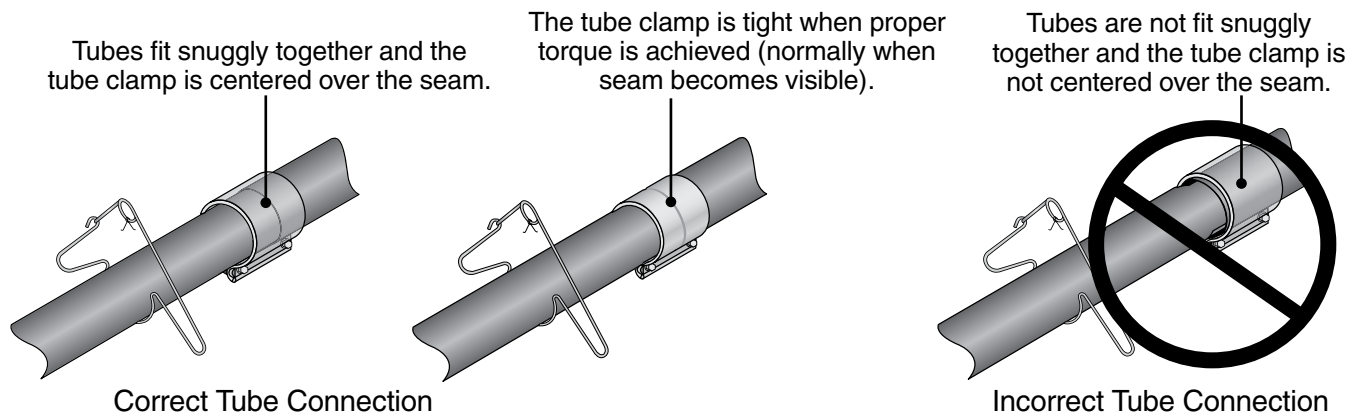

Optional U-Bend or Elbow Accessory Configurations

A 180 degree U-bend or 90 degree accessory fitting may be installed in the radiant tube heater system. Refer to page 17 for minimum distance requirements from the burner control box.

When installing a U-bend or Elbow Accessory Fitting:

- The top clearance of an uncovered (no reflector) U-bend or elbow accessory fitting to combustibles is 458mm.
- If operating the heater un-vented, separate the intake air to the heater from its exhaust products a minimum of 1220mm; further separation may be necessary (see figure 3.12). Outside combustion air may also be supplied.
- A maximum of one 180° U-bend or two 90° elbows can be installed on a heater.
- Omit one 840mm section of turbulator baffle. Refer to Baffle Assembly section.

Figure 3.11 • Optional Tube Connections

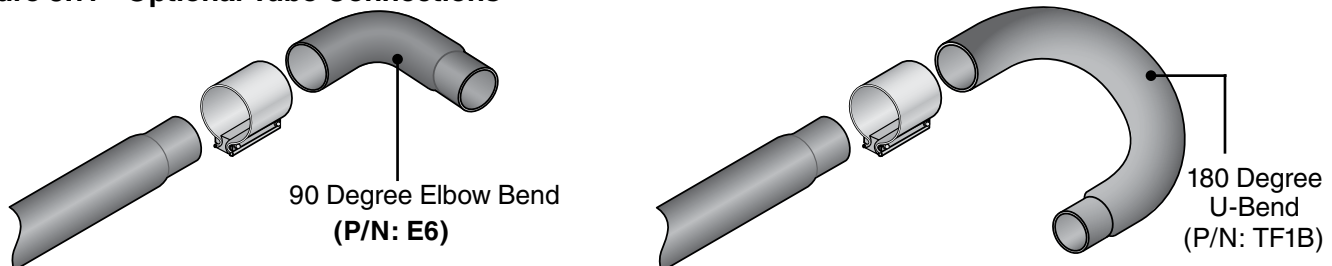

Radiant Tube Assembly

Figure 3.12 • Elbow and U-Bend Clearances

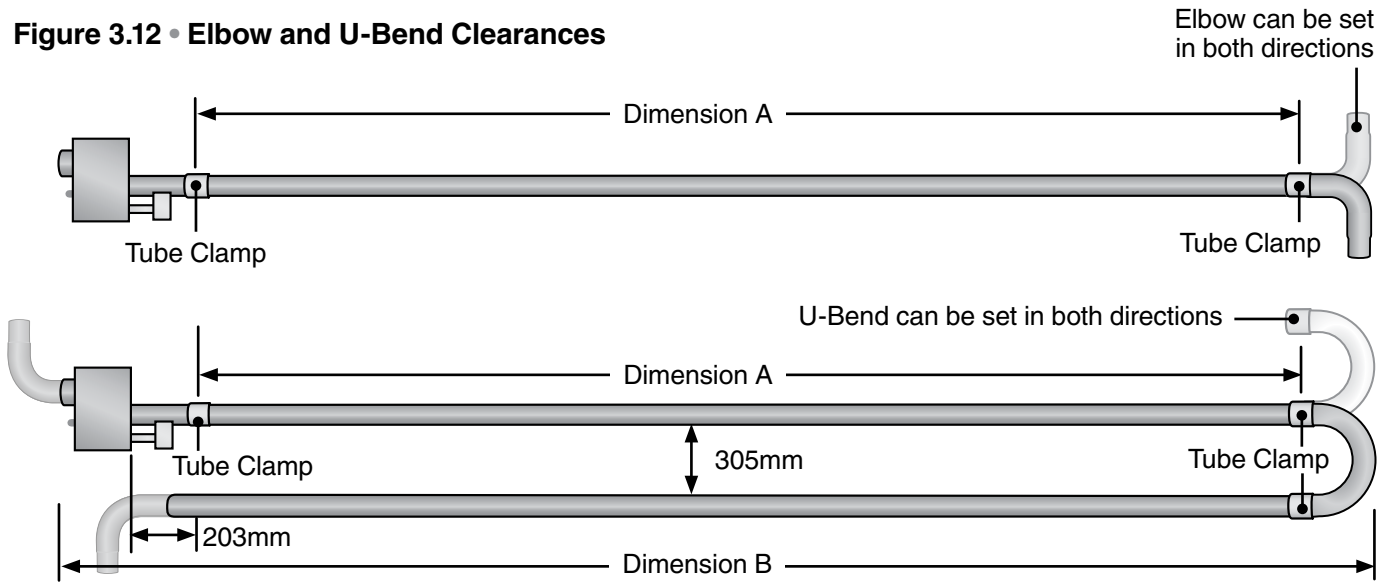
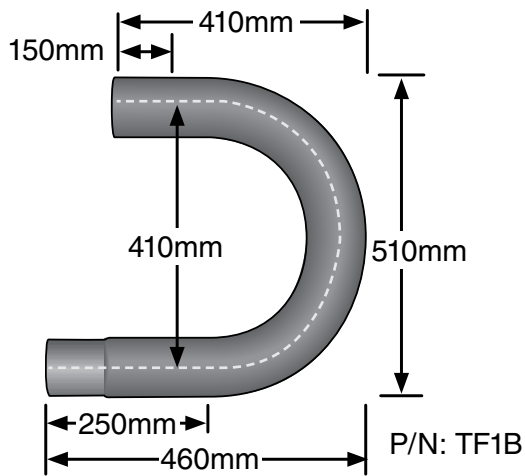

Figure 3.13 • U-Bend and Elbow Dimensions



Minimum Distance from Burner Control Box to U-Bend or Elbow Accessory

kW Range	Dimension A
14.7 - 29.3 kW	3050 mm
36.7 kW	4570 mm
43.0 - 50.0 kW	6100 mm
55.0 - 60.0 kW	7620 mm

Overall Dimensions for Heaters Configured with U-Bend (P/N: TF1B)

Heater Length	Dimension B
6M	3963 mm
9M	5385 mm
12M	6909 mm
15M	8332 mm
18M	9856 mm
21M	11328 mm

3.6 Burner Control Box Suspension

Suspending the burner control box must be done in accordance with applicable codes listed in the Safety section and these instructions.

The burner control box must be in straight alignment with the radiant tubes and level.

- ❶ Determine the mounting chain locations for hanging the burner control box.
- ❷ Fasten beam clamp, screw hook or other type of suspension anchor to hanging point.
- ❸ Attach and close S-hook and #1 double-loop chain to anchor. Check that it is securely connected.
- ❹ Attach chain assemblies and S-hooks to mounting brackets on the burner control box. Adjust chain lengths until level and in straight alignment with the radiant tubes. The burner sight glass will be visible from the floor.

Figure 3.14 • Burner Control Box Assembly • Side View

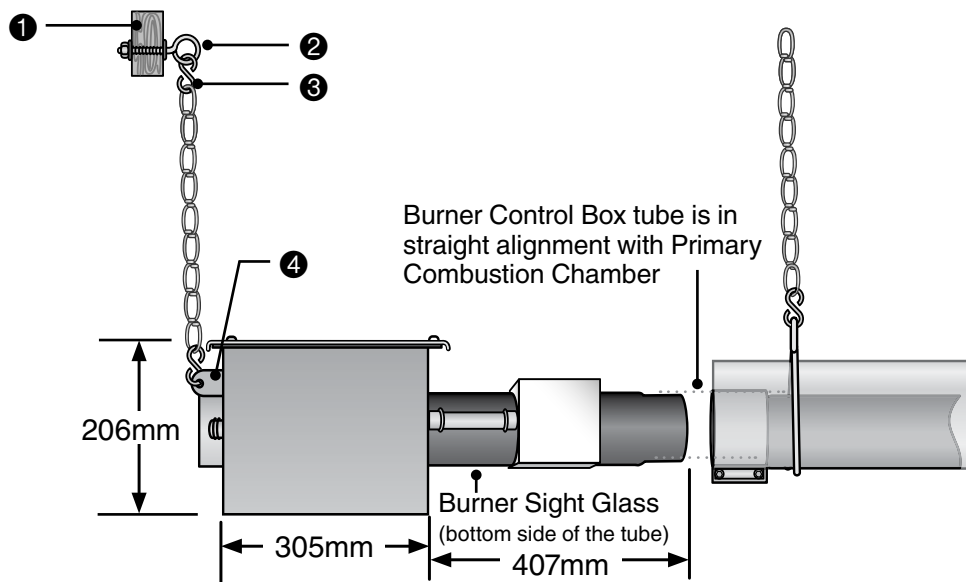
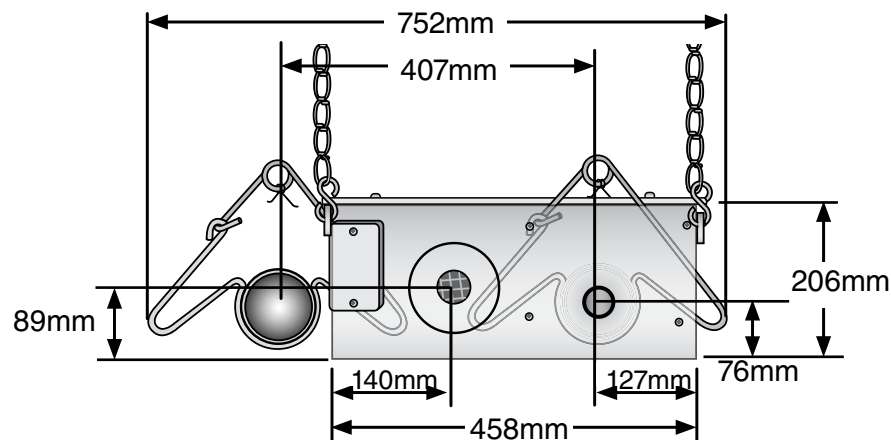

Figure 3.15 • Burner Control Box with U-Bend • End View



3.7 Reflector Assembly

To install the reflectors:

- ① Attach reflector center supports onto radiant tubes.
- ② Slide each reflector section through the hangers and adjust the reflector tension spring into the V-groove on the top of the reflector. The reflectors should overlap approximately 102mm.
- ③ To prevent the reflectors from shifting, secure the reflector sections together using sheet metal screws except at the expansion joint (see page 21). **NOTE:** Installer to provide sheet metal screws.
- ④ Attach reflector end caps, with polished side inward, to each end of the reflector run.

Reflectors, and reflector accessories, direct infrared energy to the floor level. The reflector assembly depends on the heater configuration, proximity to combustibles and the space surrounding the heater.

Before you begin assembly, determine if the use of reflector accessories are necessary (see page 20).

Figure 3.16 • Reflector Assembly

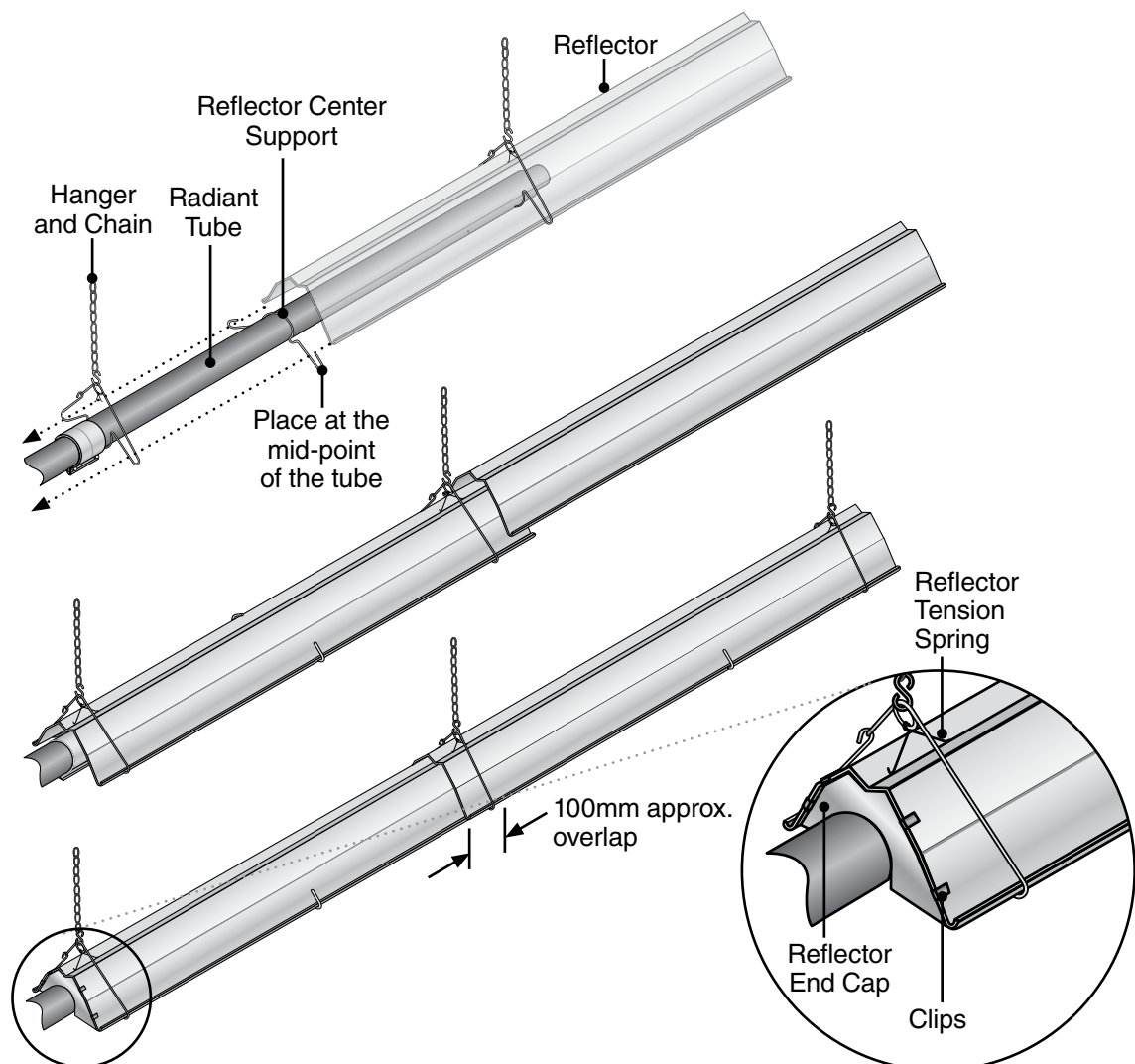

Reflector Assembly

Common Optional Accessories

Reflector Accessories	Description	Part #
Elbow Reflector*	90° bend, highly polished aluminum reflector elbow. Designed to fit atop one elbow accessory fitting.	RE
U-Reflector*	180° bend, highly polished aluminum reflector U-bend. Designed to fit atop one U-bend accessory fitting.	RU
Side Shield Reflector *^	Highly polished side shield extension used to direct infrared rays downward, away from side walls and combustibles.	SSE
Protective Guard	Used to prevent debris or objects from becoming lodged between the radiant tube and reflector. Required when mounting heaters below 8 ft.	PG

* Reflectors cannot be rotated when used with this accessory.

^ Refer to the Clearance to Combustibles chart on page 7 for minimum distances to combustibles when side shield extension(s) are used.

Figure 3.17 • Reflector Shield Accessories

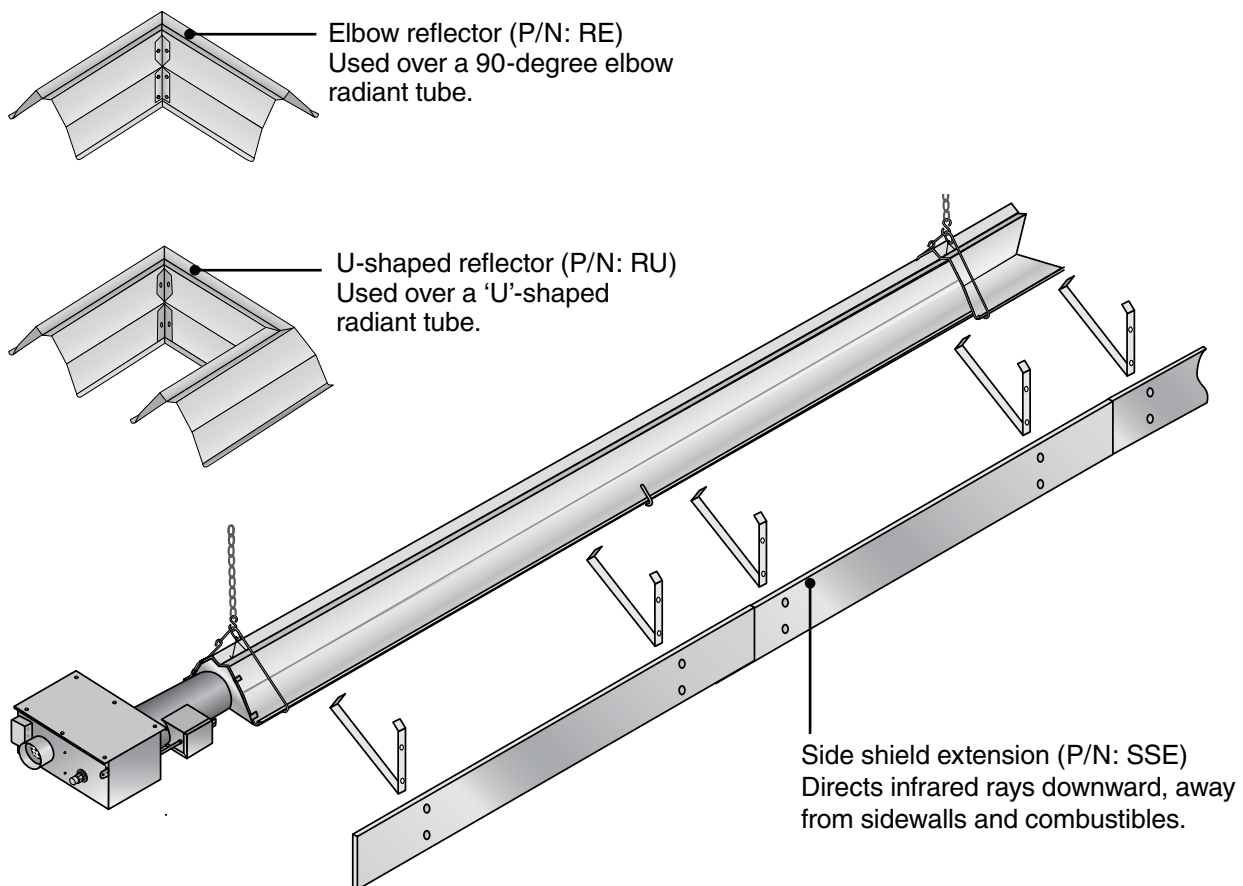

3.8 Baffle Assembly and Placement





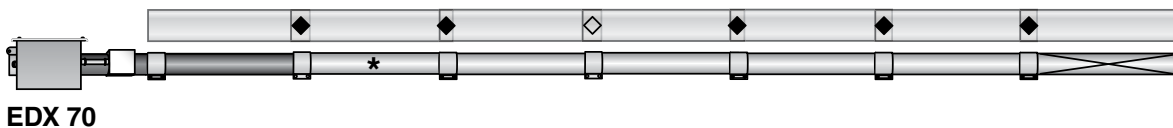
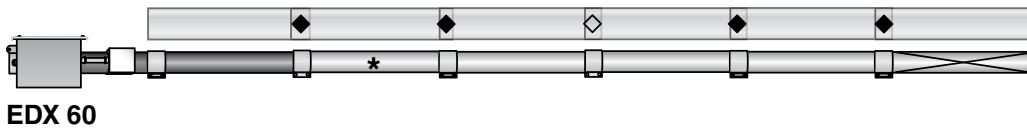
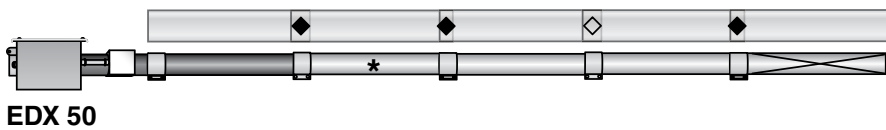
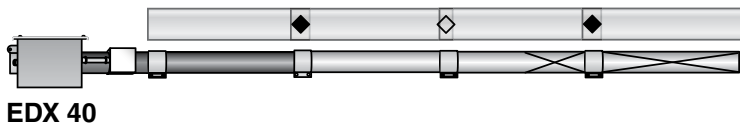
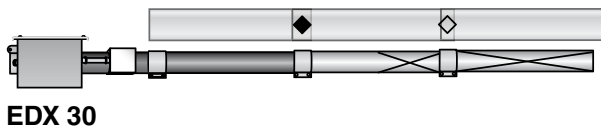
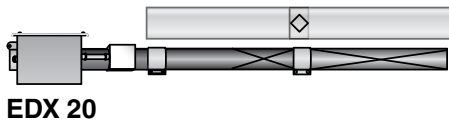

Secured Joints and Baffle Location for Reflectors

NOTICE

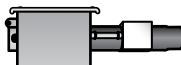
Different inputs and models utilize different baffle lengths. Remove all enclosed baffle sections from box and retain with applicable heater. Reference shipping label for proper baffle size.

Each 840mm baffle section must be assembled with other baffles and placed in the radiant tube section furthest from the burner. **IMPORTANT:** Omit one section of baffle if heater is configured with a U-bend or Elbow accessory fitting.



Key	
	Burner Control Box with Burner Tube
	Expansion joint on Reflectors
	Secured joint on Reflectors
	Primary Combustion Chamber Tube with clamp
	Radiant Tube with clamp
	Baffle location

* 43.0-60.0 kW (147-204 MBH) models utilize a secondary aluminized steel combustion chamber placed immediately downstream of the primary combustion tube.

Baffle Assembly and Placement

To assemble the baffles: Note: Baffles may be inserted into the tube while being assembled.

- ❶ Determine the number of baffles needed for your model number. Remove one 840mm baffle section if heater is installed with an elbow or U-bend accessory.
- ❷ Install the baffle tabs at a 90° angle to the baffle keyhole (see Figure 3.18).
- ❸ Insert one baffle tab into keyhole and slide completely to one side until both baffle tabs appear in the keyhole.
- ❹ Adjust the tabs to the center of the keyhole and rotate the baffle 90 degrees to lock the baffle sections together.
- ❺ Repeat this process with remaining baffle sections to complete assembly.

Figure 3.18 • Assembling the Baffles

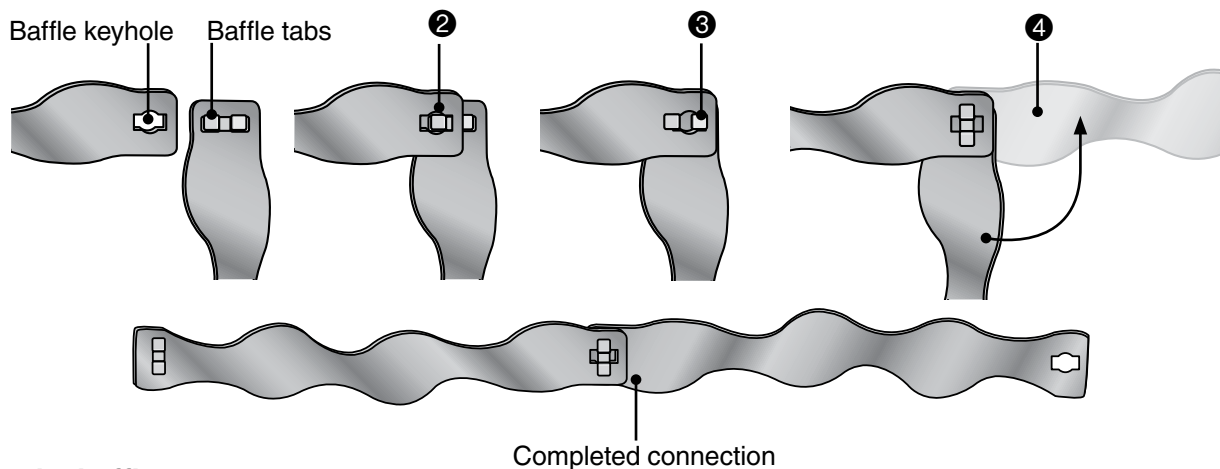

To insert the baffles:

- ❶ Insert baffles with the keyhole end first.
- ❷ Rotate baffle assembly so that it is in the vertical position.
- ❸ Slide baffle assembly into the last radiant tube section, furthest from burner control box.
Note: Baffle assemblies longer than 3048mm will continue to be fed into next tube section.

Figure 3.19 • Inserting the Baffles

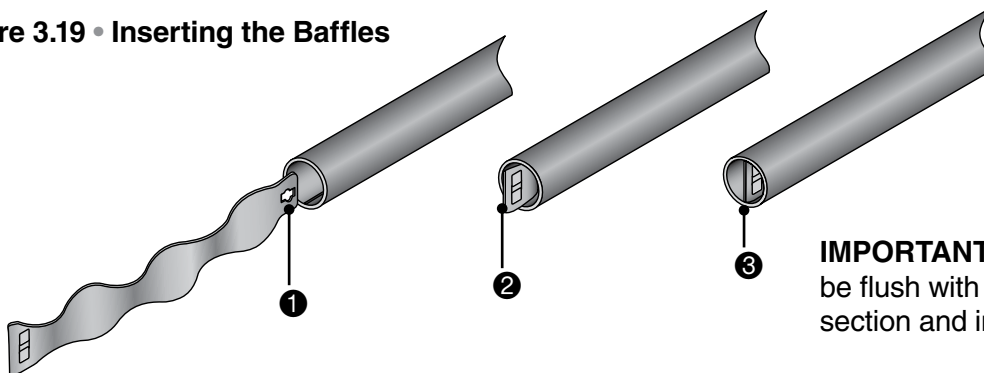

IMPORTANT: Baffle assembly must be flush with the end of the last tube section and in the vertical position.

3.9 Venting

WARNING



Insufficient ventilation and/or improperly sealed vents may release gas into the building which could result in health problems, carbon monoxide poisoning or death.

Improper venting may result in fire, explosion, injury or death.



Seal vent pipes with high temperature sealant and three (3) sheet metal screws. Vent enclosed spaces and buildings according to the guidelines in this manual and applicable national, state, provincial and local codes.

The heating system may operate either vented or un-vented (see page 27). Venting can terminate through the sidewall (horizontal) or the roof (vertical) and be individually or commonly vented.

Venting Requirements

- Seal single wall vent with high temperature sealant and three (3) sheet metal screws.
- Single wall galvanized vent pipe must be insulated in cold environments.
- Do not use more than two 90 degree elbows in the exhaust vent.
- To maintain clearances to combustibles, the use of an approved wall or roof thimble and double-wall Type B-vent is required for the portion of vent pipe that runs through combustible material in the building wall or roof (see Figures 3.20 & 3.21).
- The maximum vent length is 6100mm.

Vent Assembly

Figure 3.20 • Vent Requirements:

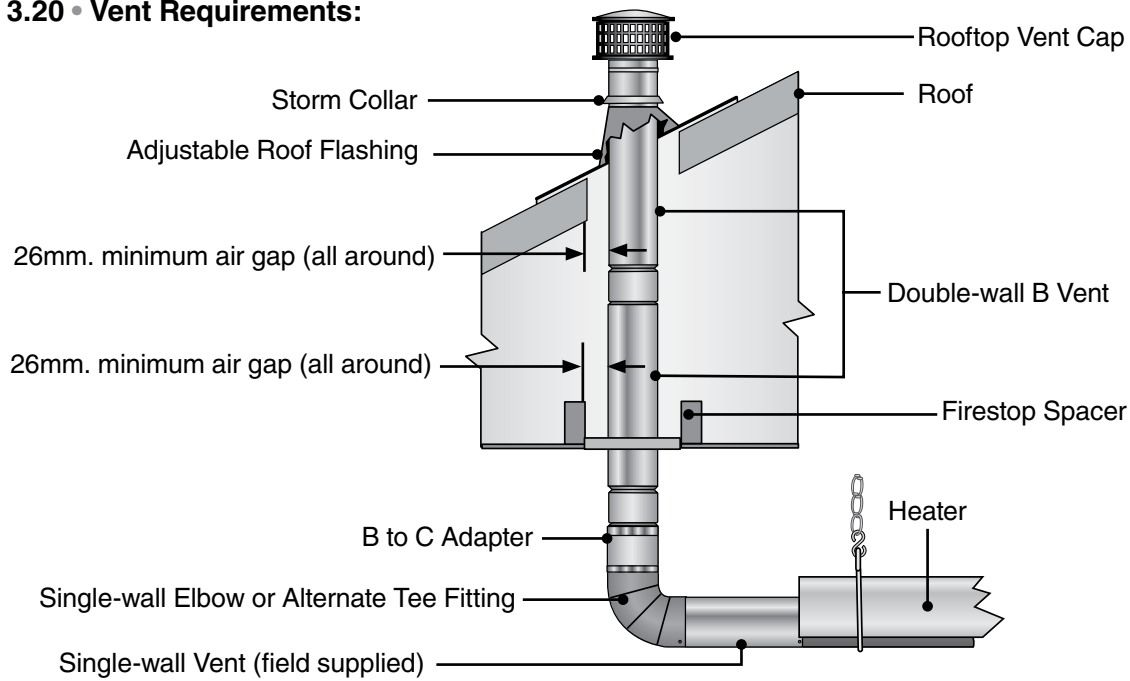

Sidewall (Horizontal) Venting

Guidelines:

- To prevent moisture from entering the heater system, slope the vent pipe down toward the outlet 20mm. per meter of vent length. Do not pitch the heater.
- Vent must extend beyond any combustible overhang.

Figure 3.21 • Vent Slope - Side View

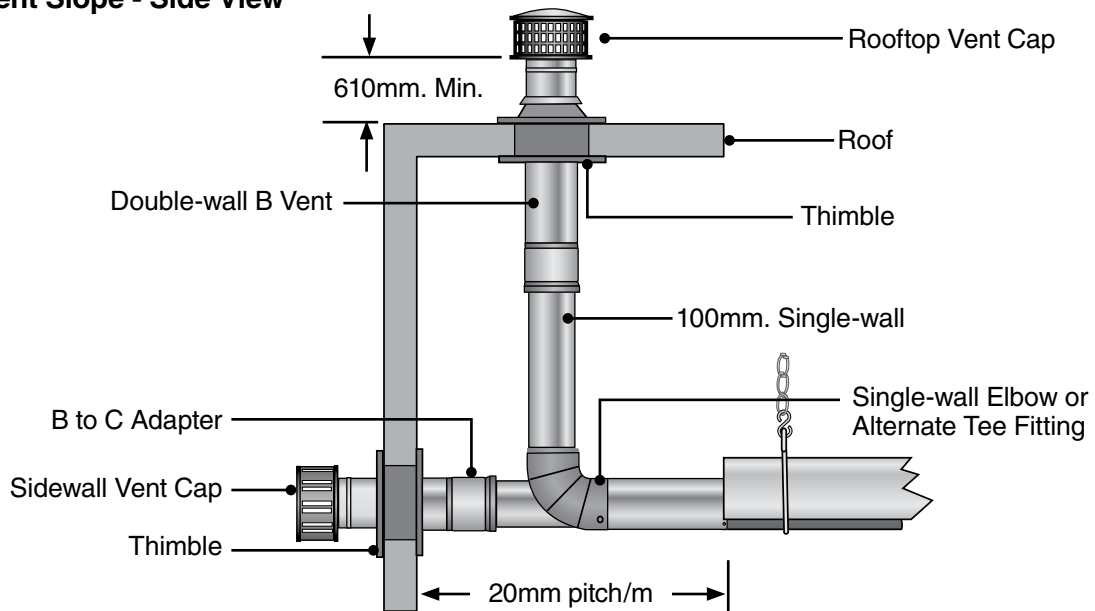

Vent Assembly

Vent Termination

- Vent must terminate a minimum of 1200mm below, 1200mm horizontally from and 300mm above any window or door that may be opened and gravity air inlet into the building.
- Vent must terminate a minimum of 900mm above any forced air inlet that is located within 3100mm.
- The bottom of the vent terminal must be located a minimum of 300mm above grade level and must extend beyond any combustible overhang. Vents adjacent to public walkways must terminate a minimum a 2100mm above grade level.
- The vent terminal must be installed to prevent blockage by snow and protect building materials from degradation by flue gases.
- The vent cap must be a minimum of 152mm from the sidewall of the building.
- Vents must extend beyond any combustible or be a minimum of 915mm below a combustible overhang.

Roof (vertical) Venting

Guidelines:

- Separate air intake duct from vent pipe a minimum of 1200mm by placing vent pipes higher than adjacent air intake duct.
- Venting may utilize standard B-vent cap.
- The vent terminal must extend a minimum of 610mm above the roof.

Figure 3.22 • Vertical Ventilation - Side View

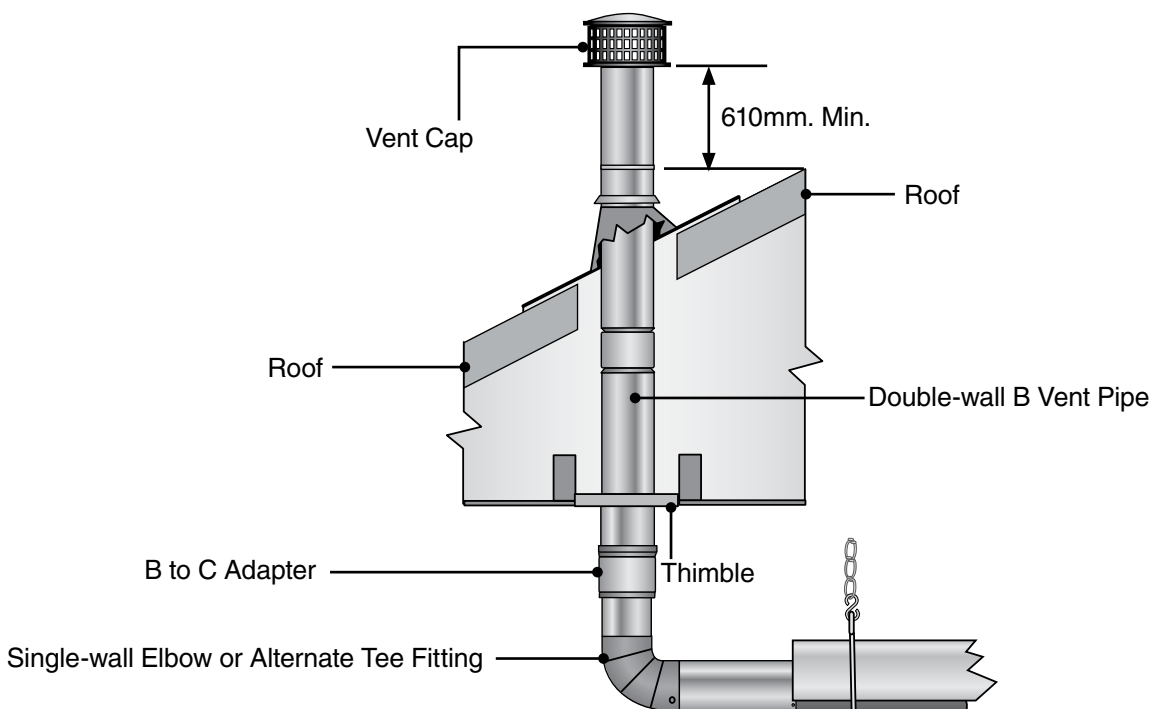

Vent Requirements

Common Venting

- A dual exhaust assembly (P/N: Y or YSM) must be used when joining two heaters to a common vent so that by-products of one heater do not flow into the adjoining vent of the other heater.
- 150mm diameter double-wall Type B-vent and 150mm vent cap must be used.
- Common vented heaters must be controlled with the same thermostat. Do not operate individually.

Figure 3.23 • Common Vertical Venting - Side View

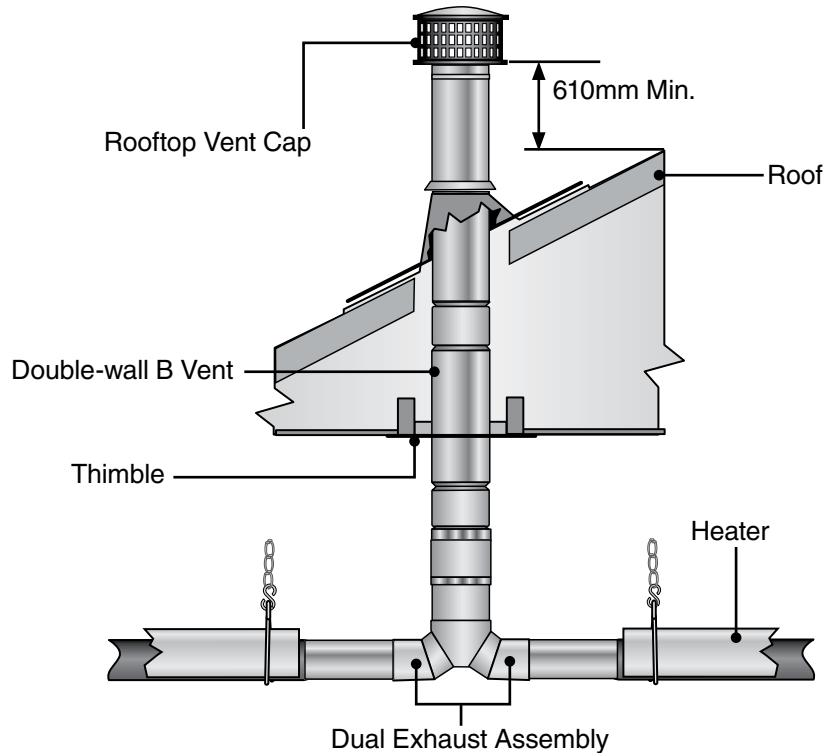
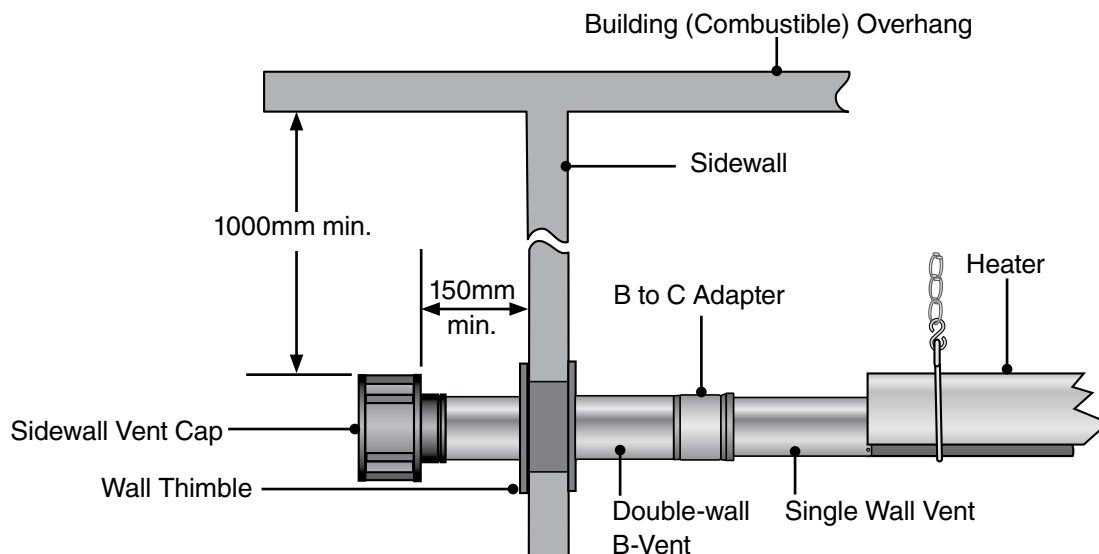

Figure 3.24 • Sidewall Venting - Side View



Optional Unvented Operation

⚠ WARNING



Not for residential use. The use of unvented tube heaters in residential indoor spaces may result in property damage, serious injury or death. Use unvented operation in commercial and industrial installations with proper ventilation rates only.

When installing in an un-vented configuration:

- A factory supplied vent cap/diffuser (P/N: WVE-GALV) must be used.
- Ventilation of the space is required to dilute the by-products of combustion. Sufficient displacement of fresh air intake and exhaust by-product must be provided.
- The minimum clearance between the air intake and the exhaust terminal is 1220mm. **Note:** When installing in a U-bend configuration, use caution to separate vent gases from heater intake.
- A minimum positive air displacement (movement) for **G20 and G25 gas**: 2m³/hr per kW is required.
- A minimum positive air displacement (movement) for **G31 Gas**: 2.3m³/hr per kW is required.

NOTE: Gravity or mechanical means may be used to accomplish the air displacement. Local codes may require that the mechanical exhaust system be interlocked with the electrical supply line to the heaters, enabling both to function simultaneously.

- The use of outside combustion air intake is recommended.

Figure 3.25 • Minimum end clearance for unvented heater



3.10 Combustion Air Requirements

NOTICE

This heater has a factory preset air orifice for proper combustion air supply. If combustion air is to be provided for a tightly closed area, 440 sq. mm of free air opening must be provided for each kW of heater input.

Non-contaminated air for combustion must be ducted to the heater if chlorinated or fluorinated contaminants, high humidity and other contaminants such as sawdust or welding smoke are present in the area where the heater is installed, or if the building has a negative pressure.

Combustion air intake may be located on either the sidewall or the roof. Figures 3.26 - 3.28.

Figure 3.26
Vertical Outside Air Supply
for Single Heater • Side View

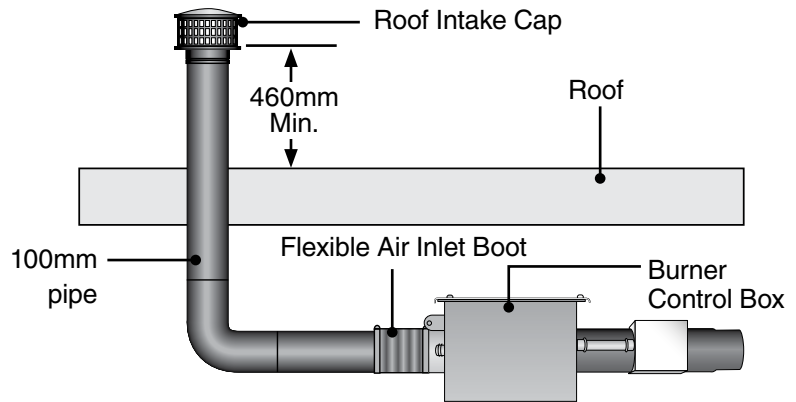

Figure 3.27
Horizontal Outside Air Supply
for Single Heater • Side View

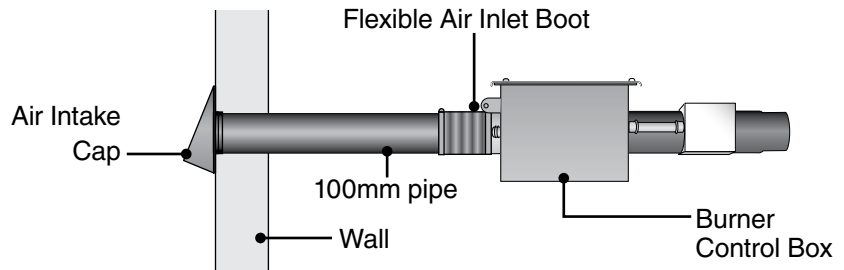
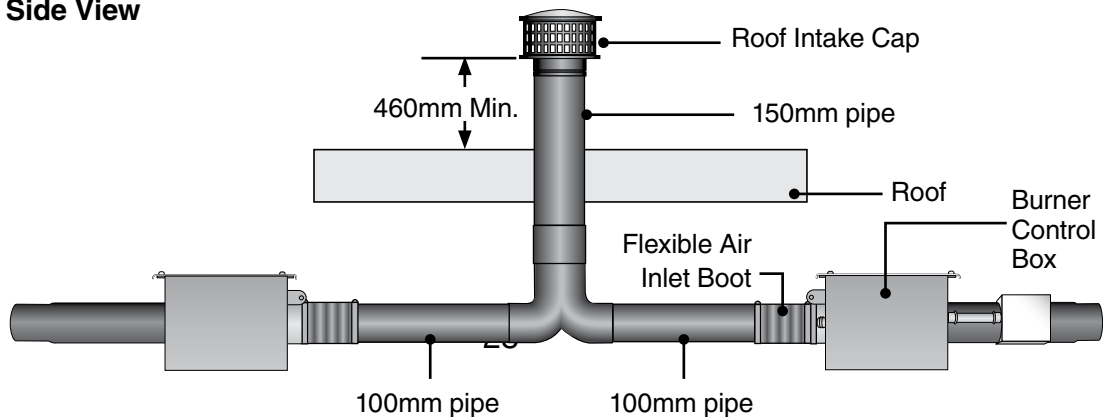

Figure 3.28
Vertical Outside Air Supply
for Double Heater • Side View

NOTE: Common intake heaters must share the same thermostat.



Combustion Air Requirements

Guidelines:

Limitations for length and size of combustion air intake duct

Single Heater Intake		Dual Heater Intake	
Air Intake Duct Size	Max. Intake Length	Duct Size	Max. Intake
100mm	6100mm	100mm.(single)/150mm.(dual)	6100mm
130mm	9140mm	100mm.(single)/200mm.(dual)	9140mm
150mm	12200mm	Consult factory for longer intake lengths.	

General Requirements:

- No more than two 90 degree elbows are allowed.
- Allow for expansion. Use a 100mm diameter flexible hose to connect the duct to the burner control box.
- In humid environments, use insulated duct, PVC pipe or DWV (drain waste vent) to prevent condensation on the outer surface.
- Do not draw air from attic space.
- A factory approved wall intake cap (P/N: WIV-4) must be used with horizontal outside air intake ducts. The wall intake cap must be installed to prevent blockage. Locate the intake where dirt, steam, snow, etc. will not contaminate or clog the intake screen.
- Separate air intake duct from vent pipe a minimum of 100mm. Also, place pipe higher than adjacent air intake duct.

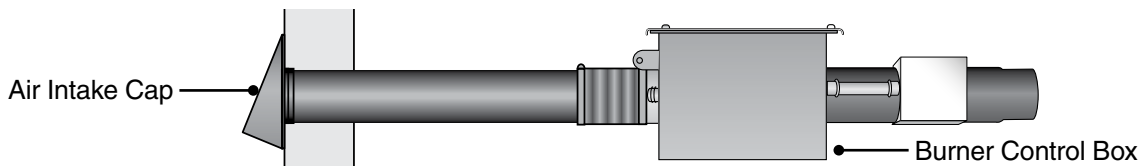

3.11 Gas Supply

⚠ WARNING



Improperly connected gas lines may result in fire, explosion, poisonous fumes, toxic gases, asphyxiation or death. Connect gas lines in accordance to national, state, provincial and local codes.

IMPORTANT! S

- **Verify that the heater's gas type (as listed on the rating plate) matches that of your application.**
- Check that the gas piping and service has the capacity to handle the total gas consumption of all heaters being installed, as well as any other gas appliances being connected to the supply line.
- Check that the main gas supply line is of proper diameter to supply the required fuel pressures.
- If utilizing used pipe, verify that its condition is clean and comparable to a new pipe. Test all gas supply lines in accordance with local codes.
- Test and confirm that inlet pressures are correct. Refer to the rating plate on the burner control box for required minimum and maximum pressures. The gas supply pipe must be of sufficient size to provide the required capacity and inlet pressure to the heater (if necessary, consult the local gas company). Do not exceed the maximum allowed pressure for the heater, the space or the gas piping system.

Gas Supply and Pressure Chart

Type of Gas	Chart	Composition	Calorific Value	Burner Setting	Minimum Inlet Pressure*	Maximum Inlet Pressure
I2H (G20) Natural	5	CH ₄ = 100 [methane]	37.78MJ/m ³	9-10 Mbar (reference chart on page 40 for your model)	11.5-12.5 Mbar (reference chart on page 40 for your model)	50 Mbar
I2L (G25) Derated Natural	6	CH ₄ = 86 N ₂ = 14 [methane]	32.49MJ/m ³	13-15 Mbar (reference chart on page 40 for your model)	15.5-17.5 Mbar (reference chart on page 40 for your model)	50 Mbar
I3P (G31) Liquified Petroleum	7	C ₃ H ₈ = 100 [petroleum]	95.65MJ/m ³	25 Mbar	27.5 Mbar	50 Mbar

* For purpose of adjustment

NOTE: Check manifold pressure at the tap on the gas valve. Readings will be above atmospheric pressure.

Gas Connection

⚠ WARNING



Failure to install, operate or service this appliance in the approved manner may result in property damage, injury or death. Only trained, qualified gas installation and service personnel may install or service this equipment.

To connect the gas:

This heater must be installed and service by trained gas installation and service personnel only.

The installation must conform with local building codes and regulations.

IMPORTANT! The heating system will expand and contract during operation. Allowances for expansion must be made between the connection to the heater and the gas supply. Excessive bending, kinks, twists or vibration must be avoided. A flexible gas connection of approved type is required. Flexible stainless steel gas connectors installed in one plane, and without sharp bends, kinks or twists is recommended.

The gas pipe and connection must be supported independently. Do not install gas supply line in a manner that bears the weight of the heater. Connect the main gas supply line with an approved flexible connector (Figure 3.29-3.30) or, if national or local codes require rigid piping, a swing joint. See the safety messages at the beginning of this section.

The gas outlet must be in the same room as the appliance and accessible. It may not be concealed within or run through any wall, floor or partition. When installing the heater in a corrosive environment (or near corrosive substances), use a gas connector suitable for the environment. Do not use the gas piping system to electrically ground the heater.

- ❶ Install a sediment trap / drip leg if condensation may occur at any point of the gas supply line. This will decrease the possibility of loose scale or dirt in the supply line entering the heater's control system and causing a malfunction. Note: High pressure gas above 50 Mbar requires a high pressure regulator and ball valve.
- ❷ Form the stainless steel flexible connector into a smooth C-shape allowing 305mm between the flexible connector's end nuts (see Figure 3.29).
- ❸ Attach the ball valve to the gas supply pipe. Apply pipe compound to NPT adapter threads to seal the joint. Use only a pipe compound resistant to LP (G31).
NOTE: Provide a 3.2mm BSP plugged tapping accessible for test gauge connection immediately upstream of gas connection to the heater (provided on ball valve).

Gas Supply

⚠ CAUTION

When using a stainless steel flexible connector, do not attach the connector nuts directly to the gas pipe supply. Connector nuts must be installed to an approved adapter.

- 4 Attach the flexible connector to the adapter and burner control box inlet. Seal the joints.
NOTE: Excessive torque on the manifold may misalign the orifice. Always use two wrenches to tighten mating pipe connections.
- 5 Final assembly must be tested for gas leaks according to relevant country codes.

IMPORTANT: Before installation, check that local distribution conditions, nature of gas and pressure, and the adjustment of the appliance are compatible.

⚠ WARNING



Testing for gas leaks with an open flame or other sources of ignition may lead to a fire or explosion and cause serious injury or death. Test in accordance with relevant codes of practice.

Figure 3.29 • Gas Connection (Flexible Gas Connection shown) • Side View

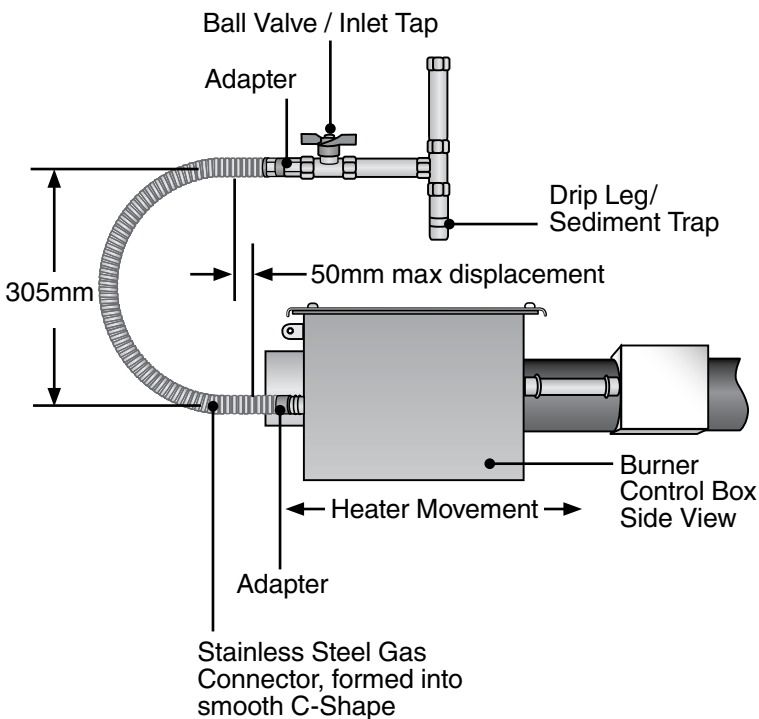
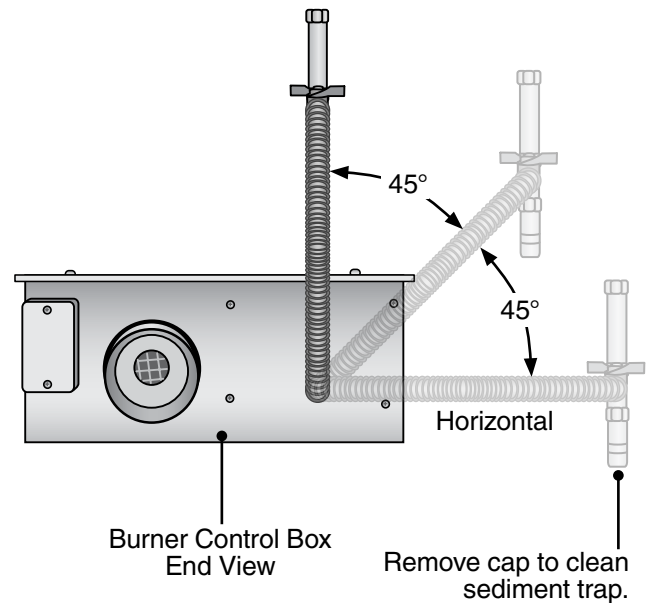

Figure 3.30 • Gas Connection (Flexible Gas Connection shown) • End View



3.12 Electrical Requirements

- Verify that the heater’s voltage (as listed on the rating plate) matches that of your application.
- Heaters operate on 230 volts, 50Hz., single phase. The amperage requirement is 0.6 Amps running current per heater.
- The heater must be grounded in accordance with the I.E.E. Regulations and local codes.
- Observe proper electrical polarity.
- The method of connection to the electrical supply must facilitate complete isolation and should preferably be made via a fuse isolator having a contact separation of at least 3mm in all poles and supplying the appliance only.
- Clearance to combustibles must be maintained between electrical apparatus and wiring (see page 7).
- Wiring must not be run above or below the heater or exposed to the radiant output.
- Installations utilizing a 24-volt thermostat require a relay transformer.

Figure 3.31 - Field Wiring Diagram

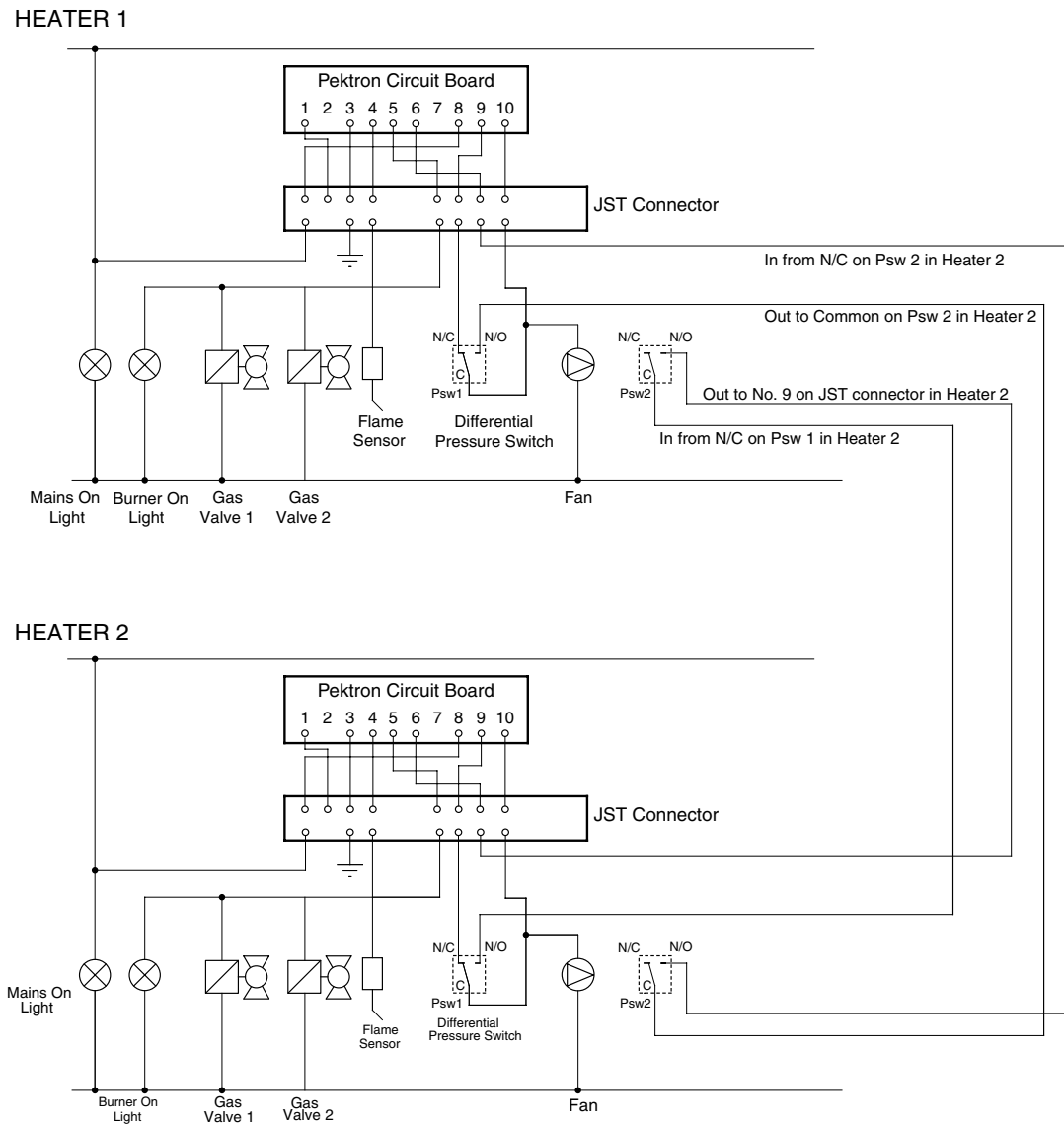

Field Wiring Diagrams

If any of the original wire as supplied with this appliance must be replaced, it must be replaced with wiring material having a temperature rating of at least 105°C.

Figure 3.32 - Internal Wiring Diagram

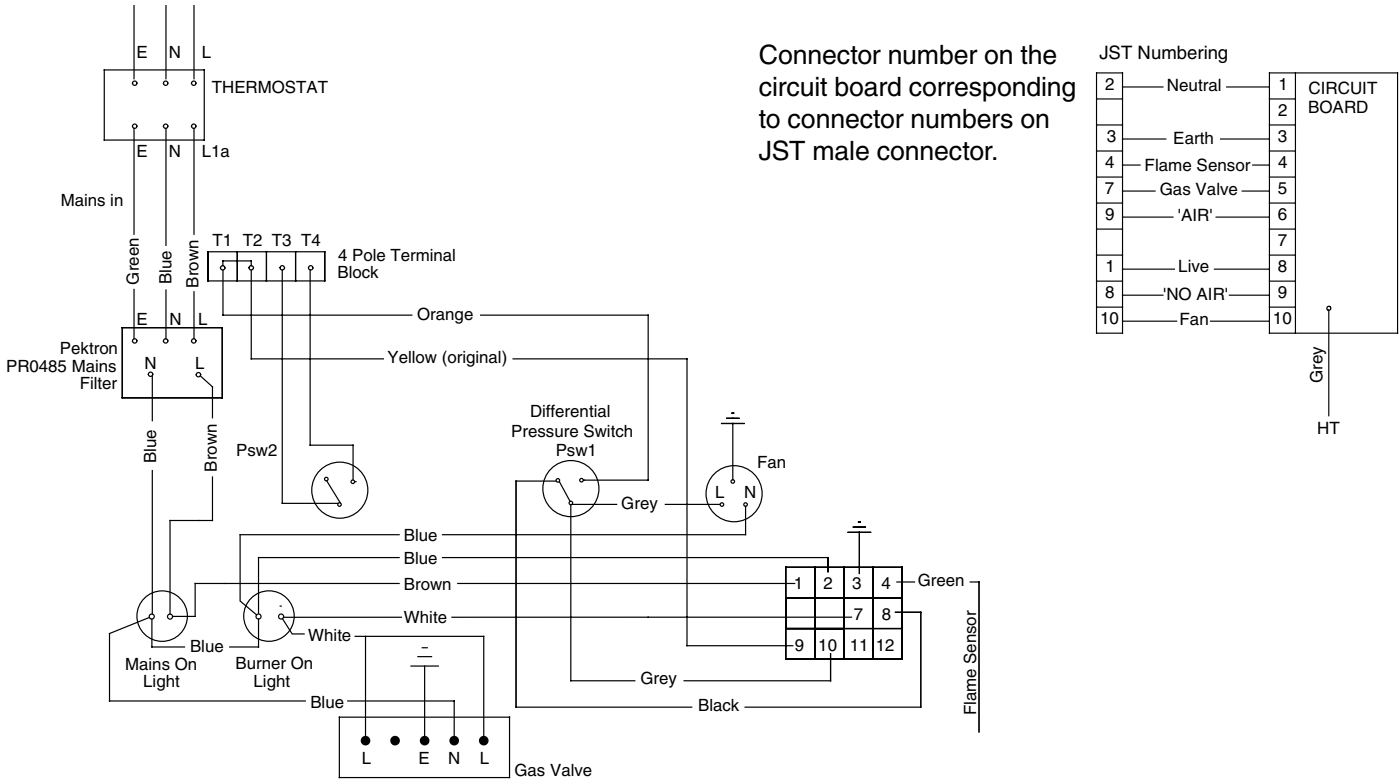
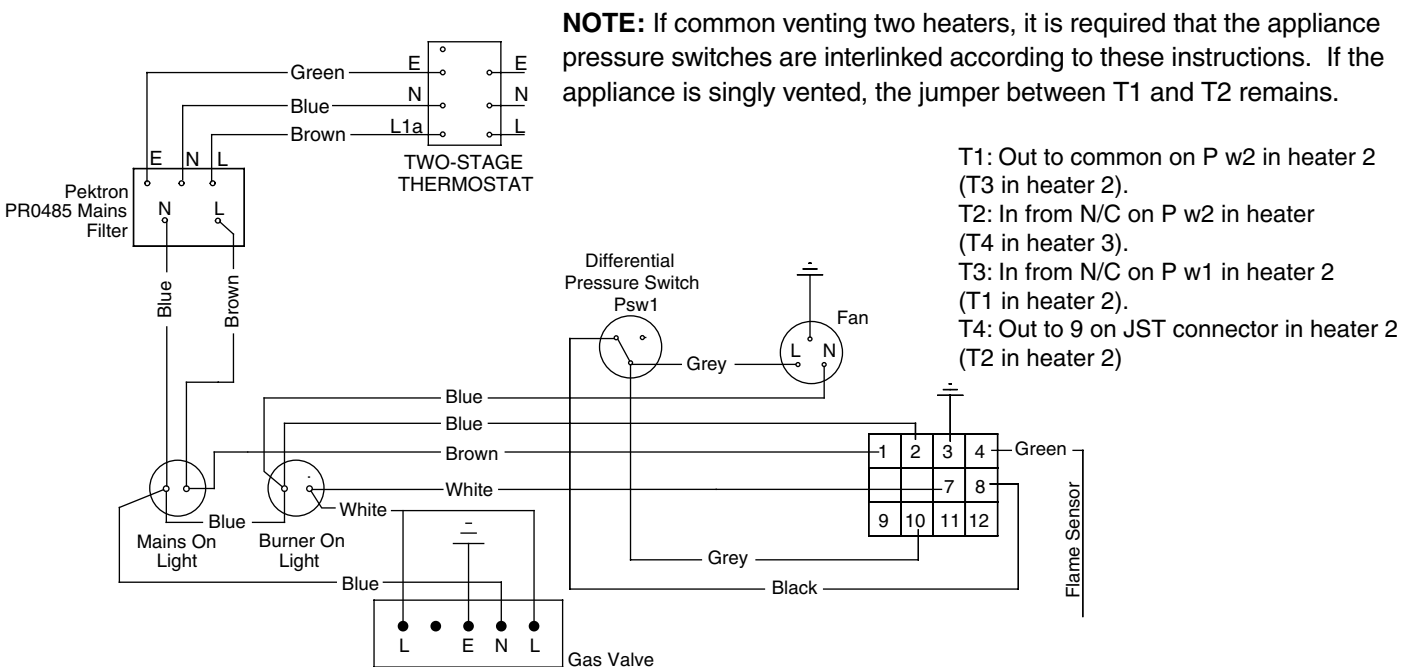

Figure 3.34 - Alternate Internal Wiring Diagram (factory installed common venting option)



4.0 Operation

⚠ WARNING



**This heater is not equipped with a pilot ignition system.
Do not attempt to light the system manually.**

Commissioning Procedures:

- 1 Ensure that ball valve to the heater is turned “OFF”.
- 2 Purge air from the gas supply line and test for gas soundness in accordance with relevant Standards.
- 3 Check that all electrical connections are made to the heater and that the unit has a sound earth connection.
- 4 Remove operating pressure test point screw and connect the pressure gauge.
- 5 Switch on power to the heater. After a purge period, the gas valve is energized and will attempt to ignite for 5-10 seconds. (If ignition fails, the heater will lock out). To reset the heater, briefly interrupt power to the heater.
- 6 With the heater running, test operating pressure. Refer to the Technical Specifications chart on page 40 for details on your particular gas type.

Lighting Procedures:

- 1 Verify that service lid is secured.
- 2 Open (turn on) gas supply to the heater.
- 3 Close (turn on) electrical circuit (typically thermostat).
- 4 If the heater fails to light, turn off gas, open electrical circuit (set thermostat to lowest setting or to off). Wait five (5) minutes before repeating above steps.

Shutdown Procedures:

- 1 Open (turn off) electrical circuit.
- 2 Close (turn off) gas supply to the heater.
- 3 Wait five (5) minutes before relighting heater.

Sequence of Operation

Starting Circuit

The blower fan is mounted in the control box and rated to supply sufficient air for combustion. Air pressure generated by the blower will cause the differential switch to close. The system is purged for 10 seconds and the control module sends a spark through the electrode. The gas valve is opened and an attempt at ignition is made for 10 seconds. If ignition fails, the heater will go into lockout until the electrical supply is interrupted for more than two seconds.

Running Circuit

After ignition, the flame rod monitors the flame. As long as flame is present, the valve is held open. If the flame is lost, the control acts to close the valve within one second and a new trial sequence identical to that at startup is initiated. If proof of flame is not established within 10 seconds, the unit will lock out. If lockout occurs, the control can be reset by briefly interrupting the power source.

Troubleshooting Guide

Chart 5.1 Troubleshooting Guide

Symptom	Possible Cause	Corrective Action
Thermostat closed, fan doesn't operate.	<ul style="list-style-type: none"> • Blown fuse. • Faulty thermostat. • Loose or disconnected wire. • Faulty fan. 	<ul style="list-style-type: none"> • Replace. • Replace. • Repair as required. • Repair or replace.
Thermostat closed. Fan operates. Electrode does not spark.	<ul style="list-style-type: none"> • Loose or disconnected wire. • Box lid or gasket not in place. • Plugged pressure switch lines. • Plugged or restricted exhaust vent. • Faulty electrode set. • Faulty pressure switch. • Faulty circuit control. 	<ul style="list-style-type: none"> • Repair as required. • Put in place. • Clean as necessary. • Remove foreign matter. • Replace. • Replace only. Do not adjust. • Replace circuit control.
Thermostat closed. Fan and electrode set operate. After 10 seconds electrode stops sparking. No ignition.	<ul style="list-style-type: none"> • Closed gas supply. • Dirty or restricted orifice. • Faulty valve or disconnected valve wire. 	<ul style="list-style-type: none"> • Open all gas connections. • Remove and clean with soft object. • Repair or replace.
Thermostat closed. Fan and electrode operate. Ignition occurs. Burner cycles off and will not recycle.	<ul style="list-style-type: none"> • No electrical ground. • Faulty circuit control. • Low gas pressure. • Poor circuit control connection. 	<ul style="list-style-type: none"> • Connect electrical ground to junction box. • Replace. • Provide required gas pressure. • Repair or replace.
Thermostat closed. Fan and electrode operate. Ignition occurs. Burner cycles off. Burner cycles on.	<ul style="list-style-type: none"> • Low gas pressure. • Baffle improperly positioned. • Faulty pressure switch. • Restricted flue vent. 	<ul style="list-style-type: none"> • Provide required gas pressure. • Reposition baffle. • Replace. • Remove foreign matter.
Loss of heater efficiency.	<ul style="list-style-type: none"> • Low gas pressure. • Dirty or restricted orifice. • Foreign matter inside burner. • Unit cycles on and off. • Reflector is dirty or not in place. • Clogged fan blower. 	<ul style="list-style-type: none"> • Provide required gas pressure. • Remove. Clean with a soft object. • Clean as necessary. • Check previous symptom. • Clean with aluminum cleaner and soft cloth. • Clean.
Radiant tube leaking burnt gases.	<ul style="list-style-type: none"> • Loose tube connections. • Holes or cracks in radiant tubes. 	<ul style="list-style-type: none"> • Ensure that tubes are fully connected and clamped properly. • Replace.
Condensation.	<ul style="list-style-type: none"> • Stack length is too long. • Light gauge flue stack used. • Contaminated combustion air. 	<ul style="list-style-type: none"> • Shorten stack length. • Minimum of 26 ga. vent pipe required. • Provide fresh air inlet duct.
Tube bowing.	<ul style="list-style-type: none"> • Insufficient combustion air. • Overfired. • Contaminated combustion air. • Heater unable to expand properly. 	<ul style="list-style-type: none"> • Provide 440 sq. mm. of free air per kW of input. • Check gas pressure and orifice size. • Provide fresh air inlet duct. • Remount with flexible inlet or vent pipe.
Tube corroding.	<ul style="list-style-type: none"> • Contaminated combustion air. 	<ul style="list-style-type: none"> • Provide fresh air inlet duct.
Visual inspection of burner operation not possible.	<ul style="list-style-type: none"> • Dirty or sooted sight glass. • Unit mounted upside-down. 	<ul style="list-style-type: none"> • Remove, clean or replace. • Mount correctly.
Stack sooting.	<ul style="list-style-type: none"> • Insufficient combustion air. • Improper gas. • Dirty fan or blockage. 	<ul style="list-style-type: none"> • Provide 440 sq. mm. of free air per kW of input. • Correct with proper gas input (or clean). • Clean fan or remove blockage.
Odor or fumes in space (normal during first firing and will subside after initial burn off, approximately 20 minutes).	<ul style="list-style-type: none"> • Vaporized solvents decomposing when contacting radiant tubes. • Evaporation of oils, solvents at floor. • Fork lifts. • Loose tube / vent connections. 	<ul style="list-style-type: none"> • Provide proper ventilation. • Provide proper ventilation. • Tighten tube clamps to 30-44 Nm. • Seal vent pipes.

6.0 Parts

Figure 6.1 • Burner Assembly Components

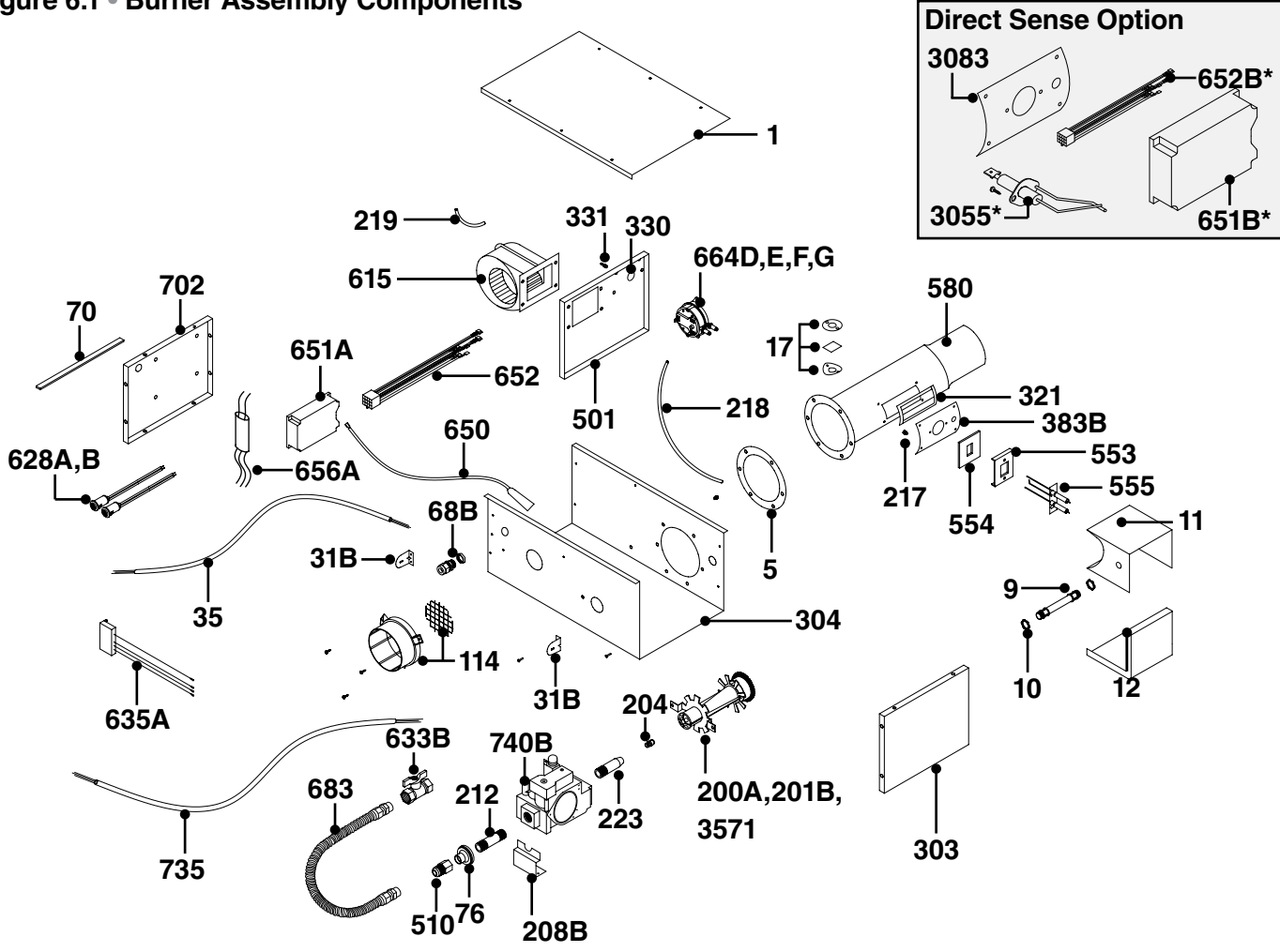

Chart 6.1 • EDX Series Parts List

Part #	Description	Part #	Description
TP-1	Control Box Cover	TP-35*	V.2 Ground wire
TP-5	Flange Gasket	TP-65I	Interlocking 838mm Baffle Section
TP-9	Conduit Coupling	TP-68B	1/2" Strain Relief Bushing
TP-10	Conduit	TP-70^	Control Box Cover Gasket (per meter)^
TP-11	Electrode Set Igniter Box	TP-76	Rubber Grommet
TP-12	Electrode Set Box Cover	TP-82	Reflector Center Support
TP-17	Sight Glass Kit	TP-105	Reflector End Cap
TP-19B	101mm Wire Hanger with Tension Spring	TP-106	Reflector End Cap Clips (8)
TP-20C	3050mm Aluminum Reflector	TP-108	1525mm Coated Alum-Titan Tube w/ Clamp
TP-20D	3050mm Stainless Steel Reflector	TP-111	1525mm Coated Aluminized Tube w/ Clamp
TP-21B	101mm Tube Clamp	TP-112	1525mm Aluminum Reflector
TP-26A	3050mm Alum. Combustion/Radiant Tube	TP-113	Reflector Tension Spring
TP-26B	3050mm Titanium Combustion Tube	TP-114	Plastic Air Orifice Collar - Consult Factory
TP-26C	3050mm Uncoated Hot Rolled Radiant Tube	TP-200A	Low SS Burner (Blue) - consult factory
TP-26D	3050mm Stainless Steel Radiant Tube	TP-201B	Mid SS Burner (Tan) - consult factory
TP-26E	3050mm Stainless Steel Combustion Tube	TP-204	Gas Orifice - Consult Factory
TP-31B	Control Box Mounting Bracket	TP-208B	Gas Valve Mounting Bracket

^ 1.83m total required to cover outer edges of the burner control box.

*Direct sense option.

Basic Parts List

Figure 6.2 • Tube & Reflector Components

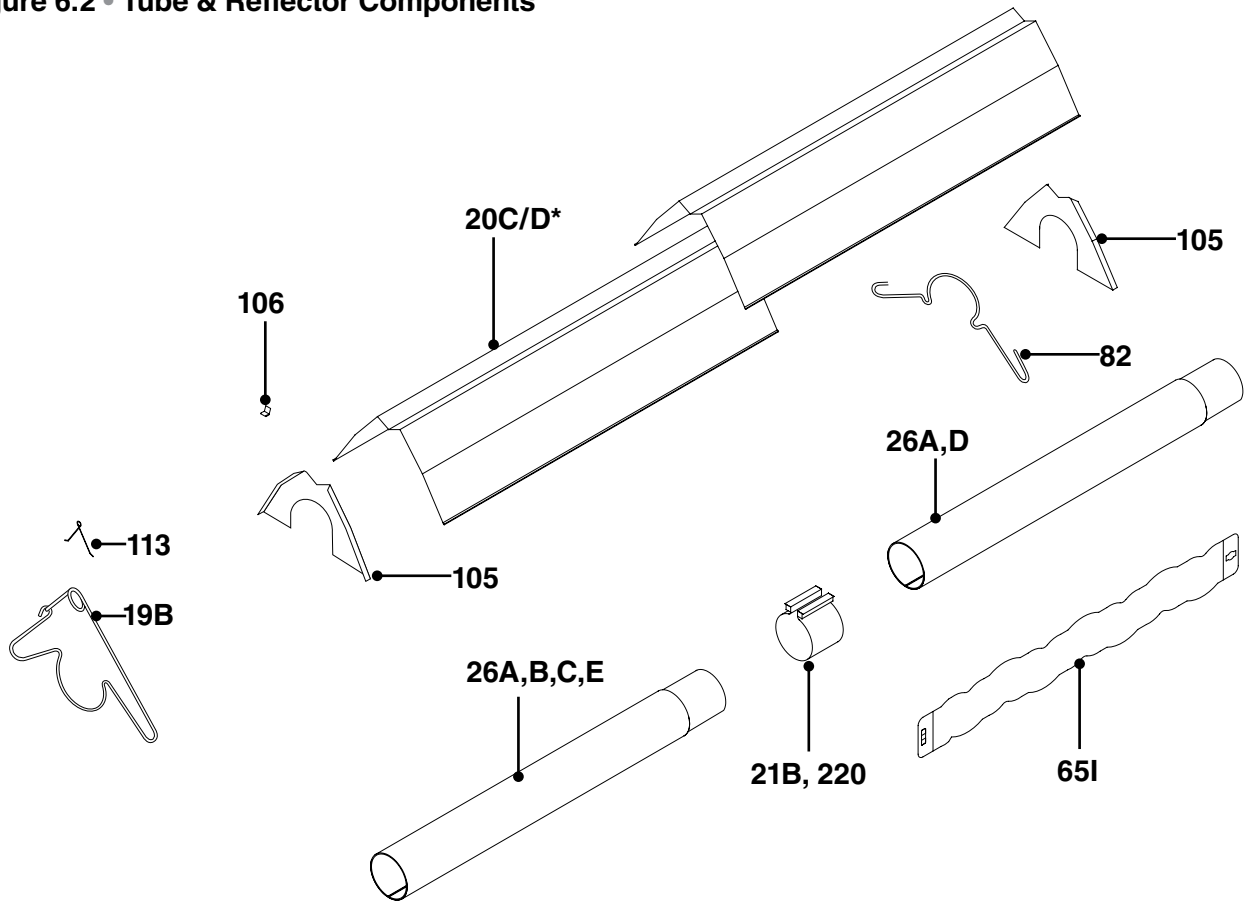





Part #	Description	Part #	Description
TP-212	Gas Valve Pipe Nipple	TP-628B	Green Indicator Light
TP-217	Pressure Barb Fitting	TP-633B	Ball Valve Shut-off
TP-218	Differential Switch Vinyl Sensing Tube (Exhaust)	TP-635A	Valve Main Coil Cord
TP-219	Differential Vinyl Sensing Tube (Burner)	TP-650	12kv High Temperature Lead w/ Rubber Boot
TP-220	101mm Stainless Steel Tube Clamp	TP-651A	Circuit Control Board
TP-223	Gas Manifold	TP-651B*	230V Pactrol Circuit Control Board
TP-303	Right End Panel - Specify Model	TP-652	Remote Sense Wiring Harness
TP-304	Control Box Outer Shell - Specify Model	TP-652B*	Direct Sense Wiring Harness
TP-321	Ignition Plate Gasket	TP-656A	Ignition Filter
TP-330	Divider Grommet	TP-664D	Normally Open Pressure Switch - .10 (25Pa)
TP-331	Green Self-Tap Ground Screw	TP-664E	Normally Open Pressure Switch - .14 (35Pa)
TP-383B	Spark Igniter Plate	TP-664F	Normally Open Pressure Switch - .20 (50Pa)
TP-501	Divider Panel - Specify Model	TP-664G	Normally Open Pressure Switch
TP-510	Flexible Gas Connector Attachment Fitting	TP-702	Left End Panel - Specify Model
TP-553	Igniter Mounting Bracket	TP-735	3 Core Cable Wire
TP-554	Igniter Mounting Bracket Gasket	TP-740B	230V Gas Valve Assembly
TP-555	Spark Igniter Electrode	TP-745	Pilot Blanking Plug
TP-580	Spark Burner Tube with Flange	TP-3055*	Direct Spark 2-Prong Electrode
TP-615	220-240V 50/60Hz Fan	TP-3571	High SS Burner (Black) - consult factory
TP-628A	Red Indicator Light	TP-3083*	Direct Spark Igniter Plate

*Direct sense option.

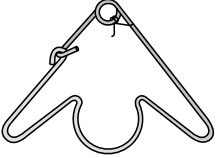
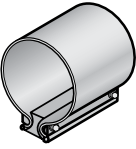
6.0 Kit Contents

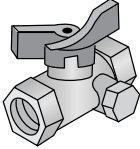
Prior to installation, verify that you have received all heater components included with your tube heater. Refer to the chart below for a list of the kit contents for your model heater. Materials not included in the kit (e.g. sheet metal screws, vent material, terminals, etc.) are the responsibility of the installer.

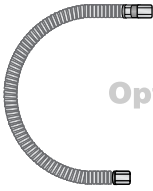
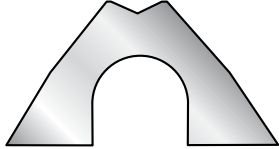
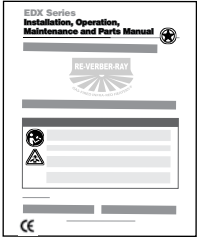
Kit Contents for EDX Series - Reference the column for your model.							
TP-19B Hanger with Reflector Tension Spring 	TP-21B Tube Clamp 	TP-82 Reflector Center Support (RCS) 	TP-633B Shut-Off Valve* (Ball Valve & Inlet Tap) Optional 	TP-106 Reflector End Caps Clips 			
TP-19E Elongated Hanger with Reflector Tension Spring Optional 	TP-683 Stainless Steel Flexible Gas Connector* Optional 		TP-105 Reflector End Caps 		Installation, Operation and Maintenance Manual F/N: LIOEDXc 		
Part No.	Description	EDX 20	EDX 30	EDX 40	EDX 50	EDX 60	EDX 70
TP-19B	Hanger w/ Tension Spring	3	4	5	6	7	8
TP-19E*	Elongated AG Hanger*	Opt.	Opt.	Opt.	Opt.	Opt.	Opt.
TP-21B	Tube Clamp	2	3	4	5	6	7
TP-82	Reflector Center Support	2	3	4	5	6	7
TP-105	Reflector End Cap	2	2	2	2	2	2
TP-106	Reflector End Cap Clip	8	8	8	8	8	8
TP-633B*	Shut-off Valve & Inlet Tap*	Opt.	Opt.	Opt.	Opt.	Opt.	Opt.
TP-683*	S.S Flexible Gas Connector*	Opt.	Opt.	Opt.	Opt.	Opt.	Opt.
LIOEDXc	EDX Installation Manual	1	1	1	1	1	1
Filled by:							

* Optional Accessory.